



**WACKER
NEUSON**

Ersatzteilkatalog
Spare parts catalog
Catálogo de piezas de repuesto
Catalogue de pièces de rechange

**Vibrationsplatte
Vibratory plate
Plancha vibratoria
Plaque vibrante**

WP1550Aw US



Type	WP1550Aw US
Material Number	5100018324
Version	103
Language	de en es fr



www.wackerneuson.com

Copyright © 02.2023
Wacker Neuson Produktion GmbH & Co. KG
Printed in Germany.
All rights reserved.

Ein Typenschild mit Typ, Artikelnummer, Version und Maschinen-Nummer ist an jedem Gerät angebracht. Die Daten von diesem Schild bitte notieren, damit sie auch bei Verlust oder Beschädigung des Schildes noch vorhanden sind. Der Typ, die Artikelnummer, die Versions-Nummer und die Maschinen-Nummer sind bei der Ersatzteilbestellung oder Nachfragen bezüglich Service-Informationen stets erforderlich.

Bei den in den Ersatzteillisten fettgedruckten Nummern handelt es sich um empfohlene Ersatzteile. Dies bedeutet, daß diese Teile bei normalen Anwendungsbedingungen natürlicher Abnutzung ausgesetzt sind und gelegentlich ersetzt oder überarbeitet werden müssen. Es wird geraten, diese Teile auf Lager bereit zu haben, um für Service-Arbeiten an diesem Gerät vorbereitet zu sein. Lagerbestände für diese und andere Teile, welche für ausgiebigere Reparaturarbeiten benötigt werden, können je nach Service-Gewohnheiten der einzelnen Kunden variieren.

Die Nummern meines Gerätes sind:

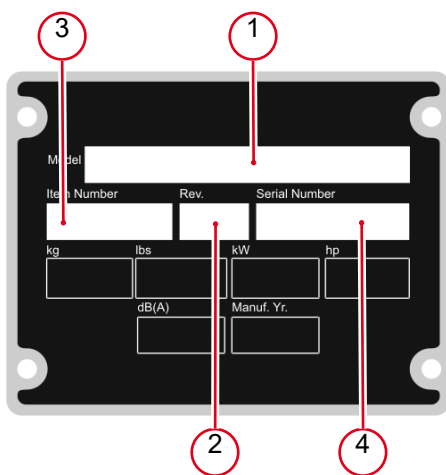

- 1. Typ
- 2. Version
- 3. Artikel-Nr.
- 4. Maschinen-Nr.

Umrechnungstabelle

Volumeneinheit	
1 ml	0.034 US fl.oz.
1 l	0.260 gal
Längeneinheit	
1 mm	0.039 in
1 m	3.280 ft
Gewicht	
1 kg	2.200 lbs
1 g	0.035 oz
Geschwindigkeit	
1 km/h	0.620 mph
Drehmoment	
1 Nm	0.740 ft.lbs

A nameplate listing the Model Number, Item Number, Revision, and Serial Number is attached to each unit. Please record the information found on this plate so it will be available should the nameplate become lost or damaged. When ordering parts or requesting service information, you will always be asked to specify the model, item number, revision number, and serial number of the unit.

Part Numbers appearing in boldface type are recommended spare parts. This means that these parts are subject to wear under normal operating conditions and may require periodic service or replacement. It is recommended that these items be stocked to meet the expected service requirements of this model. Actual stocking quantities of these and other parts used in more extensive repairs will depend on the service practices of each customer.

My machine's numbers are:

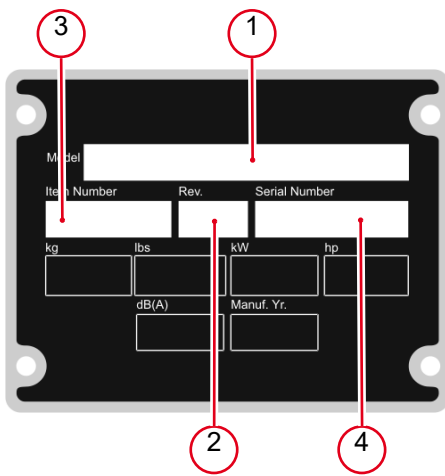

1. Model
2. Revision
3. Item No.
4. Serial No.

Conversion table

Volume unit	
1 ml	0.034 US fl.oz.
1 l	0.260 gal
Unit of length	
1 mm	0.039 in
1 m	3.280 ft
Weight	
1 kg	2.200 lbs
1 g	0.035 oz
Speed	
1 km/h	0.620 mph
Torque	
1 Nm	0.740 ft.lbs

Una placa de identificación con el modelo, número de referencia, nivel de revisión y número de serie ha sido añadida en cada máquina. Favor de anotar los datos en la placa en caso de que la placa de identificación sea destruida o perdida. En todos los pedidos para repuestos necesita siempre el modelo, el número de referencia, el nivel de revisión y el número de serie de la máquina en cuestión.

Los números de partes en negritas en las Listas Ilustradas de Partes son los repuestos recomendados, esto quiere decir que estas partes se desgastarán bajo circunstancias de funcionamiento normales y pueden requerir servicio periódico o su reemplazo. Se recomienda que el cliente mantenga un abastecimiento adecuado de estas partes para poder satisfacer la demanda requerida por el servicio a la máquina. La cantidad de repuestos que el cliente necesitará para reparaciones dependerá de la póliza de servicio de cada cliente.

Los números de mi máquina son:

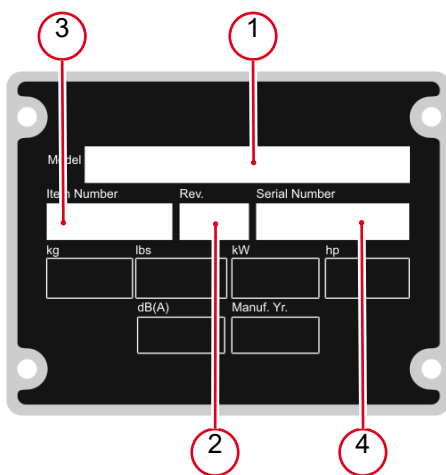

1. Modelo
2. Nivel de revisión
3. Número de referencia
4. Número de Serie

Tabla de conversión

Unidad de volumen	
1 ml	0.034 US fl.oz.
1 l	0.260 gal
Unidad de longitud	
1 mm	0.039 in
1 m	3.280 ft
Peso	
1 kg	2.200 lbs
1 g	0.035 oz
Velocidad	
1 km/h	0.620 mph
Par de apriete	
1 Nm	0.740 ft.lbs

Une plaque signalétique mentionnant le modèle, le numéro de référence, le niveau de revision et le numéro de série est fixée sur chaque machine. Veuillez noter les informations relevées sur cette plaque de façon à ce qu'elles soient toujours disponibles si la plaque signalétique venait à être perdue ou endommagée. Lorsque vous commandez des pièces détachées ou vous sollicitez des informations après-vente, on vous demandera toujours de préciser le modèle, le numéro de référence, le niveau de revision et le numéro de série de la machine.

Les numéros de pièces imprimés en caractères gras dans les Listes des Pièces Détachées de ce manuel sont les pièces détachées recommandées par la Wacker. Cela veut dire que ces pièces sont sujettes à usure dans des conditions de travail normales et peuvent nécessiter de l'entretien ou leur remplacement. Nous recommandons que vous disposiez d'un stock de ces pièces pour pouvoir satisfaire la demande d'entretien de cette machine. Le client doit décider lui-même de la quantité exacte de pièces de rechange qu'il disposera dans ses stocks.

Les numéros de ma machine sont :



1. Typ
2. Version
3. Artikel-Nr.
4. Maschinen-Nr.

Table de conversion

Unité de volume	
1 ml	0.034 US fl.oz.
1 l	0.260 gal
Unité de longueur	
1 mm	0.039 in
1 m	3.280 ft
Poids	
1 kg	2.200 lbs
1 g	0.035 oz
Vitesse	
1 km/h	0.620 mph
Couple de serrage	
1 Nm	0.740 ft.lbs

Vibrationsplatte Kpl.
 Vibratory plate cpl.
 Plancha vibradora cpl.
 Plaque vibrante cpl. 10

Vibrationsplatte Kpl.
 Vibrationsplatte kpl.
 Plancha vibradora cpl.
 Plaque vibrante cpl. 12

Bügel Kpl.
 Shackle cpl.
 Estribo cpl.
 Étrier cpl. 14

Erreger Kpl.
 Exciter cpl.
 Excitador cpl.
 Excitateur cpl. 16

Berieselungsanlage Kpl.
 Water system cpl.
 Sistema de rociado cpl.
 Système diffuseur cpl. 18

Aufkleber
 Labels
 Calcomanias
 Autocollants 20

Motor GX160 Zyklon
 Engine gx160 zyklon
 Motor gx160 zyklon
 Moteur gx160 zyklon

Seilzugstarter
 Starter
 Arrancador
 Démarreur 22

Gebläseabdeckung
 Fan hood
 Tapa de ventilador
 Couvercle du sys. de vent. 24

Vergaser
 Carburetor
 Carburador
 Carburateur 26

Luftfilter
 Air cleaner
 Filtro del aire
 Filtre à air 28

Schalldämpfer
 Muffler
 Silenciador
 Silencieux 30



Kraftstofftank Fuel tank Depósito de combustible Réservoir à essence	32
Schwungrad Fly wheel Volante Volant	34
Zylinderkopf Cylinder head Culata Culasse	36
Zündspule Ignition coil Bobina de encendido Bobine d'allumage	38
Regler Governor Regulador Régulateur	40
Zylindergehäuse Cylinder housing Carcasa de cilindro Carter cylindre	42
Kurbelgehäuseabdeckung Crankcase cover Cubierta da la caja de manivel Couvercle carter de manivelle	44
Kurbelwelle Crankshaft Cigüeñal Vilebrequin	46
Kolben Piston Pistón Piston	48
Nockenwelle Camshaft Arbol de levas Arbre à cames	50
Aufkleber Label Calcomania Autocollant	52
Wergzeug Tool Herramienta Outil	54

Zubehör
Accessories
Accesorios
Accessoires

Gleitvorrichtung PGV 1550 Urethane pad kit pgv 1550 Placa de deslizamiento pgv 1550 Jeu de tapis en polyuréthane	56
---	----

Fahrgestell Kpl. Trolley cpl. Dispositivo de transporte cpl. Chassis cpl.	58
---	----

Berieselungsanlage Kpl. Water system cpl. Sistema de rociado cpl. Système diffuseur cpl.	60
--	----

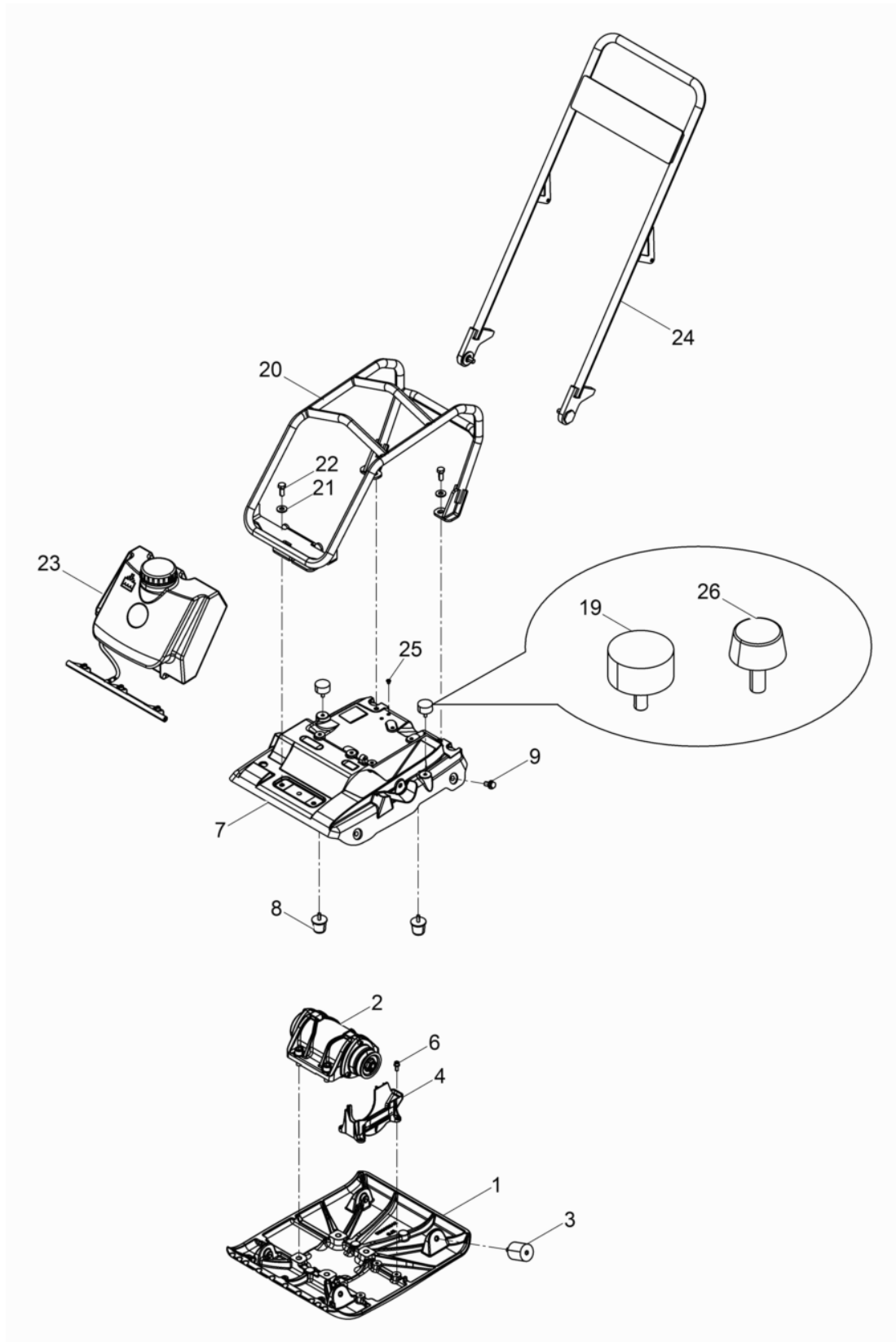

Pos. Item	Artikel Nr. Item no.	Pc.	Unit	Beschreibung Descripción	Description Description	Abm. Dim.	Norm Standard
						Drehmoment Torque	Schmierstoff Lubricant
1	5100016243	1	pc	Untermasse Masa inferior	Baseplate Masse inferieure		
2	5100016322	1	pc	Erreger Kpl. Excitador cpl.	Exciter cpl. Excitateur cpl.		
3	5100016316	4	pc	Gummi-Metall-Puffer Tope caucho-metal	Shockmount Tampon metallique oscillant	50x55 40Nm/30ft.lbs	
4	5100018341	1	pc	Riemenschutz Unten Protección de la polea inferior	Belt guard below Protection de courroie		
6	5100042618	4	pc	Zylinderschraube Tornillo cilíndrico	Cheese head screw Vis à tête cylindrique	24Nm/18ft.lbs	
7	5100016326	1	pc	Konsole Soporte	Bracket Support		
8	5100016327	2	pc	Anschlagpuffer Amortiguador	Shockmount Silentbloc	35 x 40 11Nm/8ft.lbs	
9	5100018059	4	pc	Sicherungsschraube Tornillo de seguridad	Corrugated-head screw Vis de sécurité	38Nm/28ft.lbs	
19	5100017108	2	pc	Gummi-Metall-Puffer Tope caucho-metal	Shockmount Tampon métallique oscillant	40x20 11Nm/8ft.lbs	
20	5100045328	1	pc	Schutzrahmen Armazón de protección	Protective frame Cadre protection		
21	5000031565	4	pc	Spannscheibe Arandela elástica	Lockwasher Rondelle de ressort	12	DIN6796
22	5000011422	4	pc	Sechskantschraube Tornillo hexagonal	Hexagonal head cap screw Vis à tête hexagonale	M12 x 35 86Nm/63ft.lbs	DIN933
23	5100028981	1	pc	Berieselung Kpl. Systema de riego cpl.	Sprinkler system cpl Installation d'arrosage cpl.		
24	5100028955	1	pc	Bügel Kpl. Estribo cpl.	Guide handle cpl. Étrier cpl.		
25	5002006531	4	pc	Verschlußstopfen Tapón	Push-in plug Bouchon	0,285in	

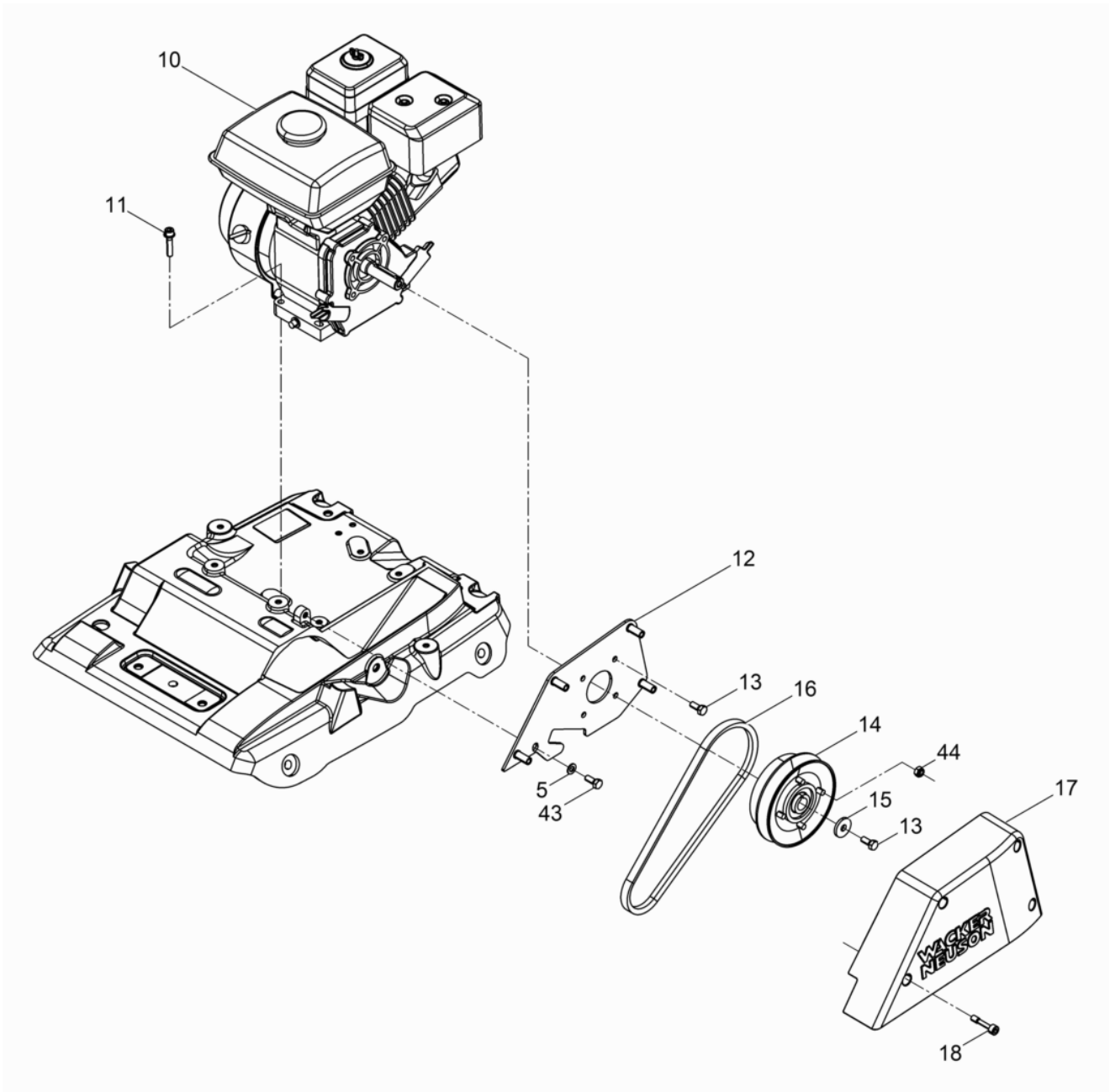

Pos. Item	Artikel Nr. Item no.	Pc.	Unit	Beschreibung Descripción	Description Description	Abm. Dim.	Norm Standard
						Drehmoment Torque	Schmierstoff Lubricant
5	5000010622	1	pc	Scheibe Arandela	Flat washer Rondelle		
10	5100046324	1	pc	Benzinmotor Motor a gasolina	Gas engine Moteur à essence		
11	5100036848	4	pc	Zylinderschraube Tornillo cilíndrico	Cheese head screw Vis à tête cylindrique	25Nm/18ft.lbs	
12	5100016434	1	pc	Keilriemenschutzblech Placa de protección	V-belt guard plate Plaque de protection		
13	5000026169	5	pc	Sechskantschraube Tornillo hexagonal	Hexagonal head cap screw Vis à tête hexagonale	5/16in-24UNF-2Ax 3/4in 18Nm/13ft.lbs	
14	5100016313	1	pc	Fliehkraftkupplung Embrague centrifugo	Centrifugal clutch Embrayage centrifuge		
15	5100016321	1	pc	Scheibe Arandela	Washer Rondelle		
16	5100044733	1	pc	Keilriemen Correa en v	V-belt Courroie		
17	5100025502	1	pc	Riemenschutz Protección de la polea	Belt guard Protection de courroie		
18	5000216658	4	pc	Dünnschaftschraube Tornillo	Screw Vis	M 8x 38	
43	5000012362	1	pc	Sechskantschraube Tornillo hexagonal	Hexagonal head cap screw Vis à tête hexagonale	25Nm/18ft.lbs	
44	5000033356	4	pc	Sechskantmutter Tuerca hexagonal	Hexagon nut Écrou hexagonal		

Bügel Kpl.
Shackle cpl.
Estribo cpl.
Étrier cpl.

WP1550Aw US

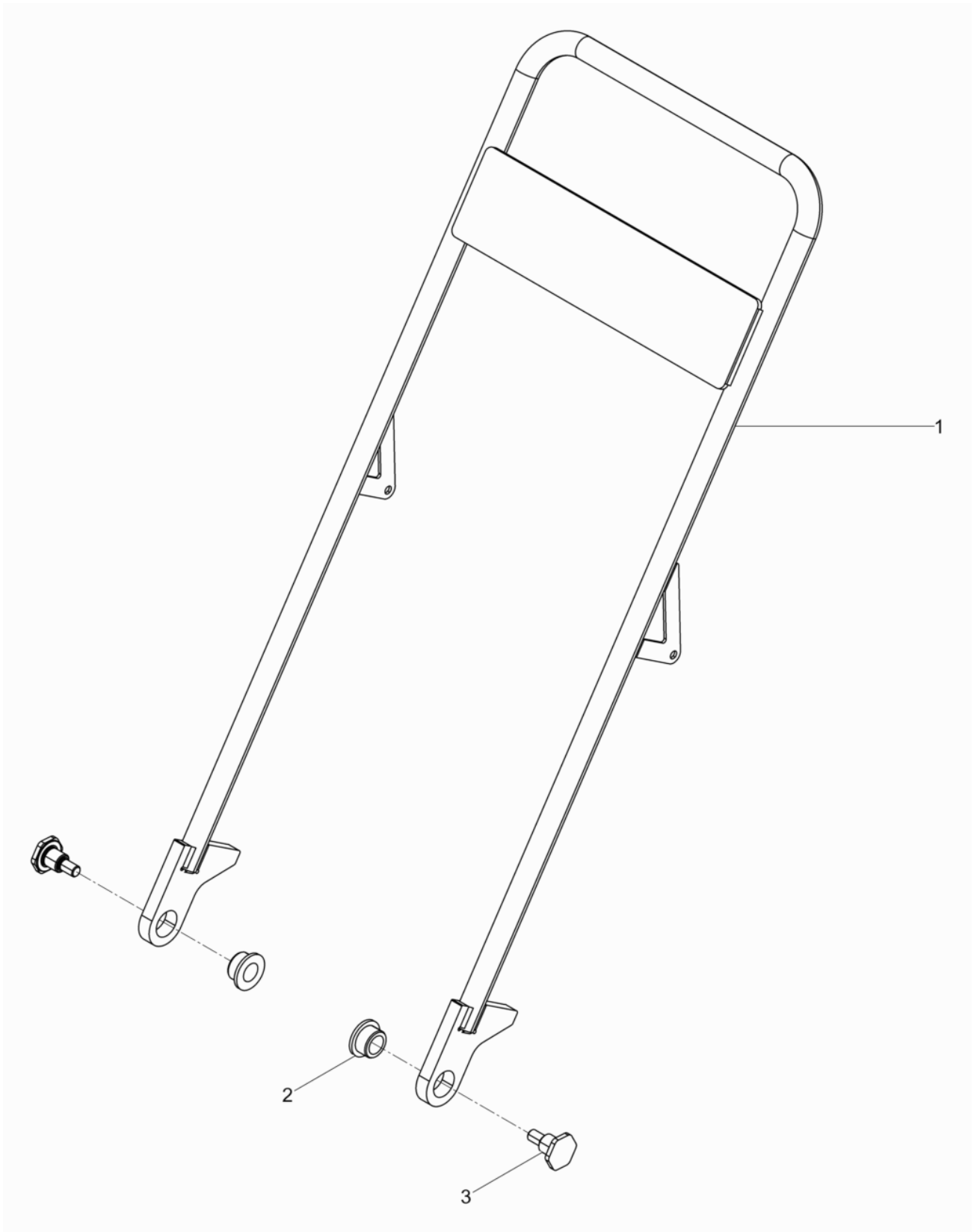

Pos. Item	Artikel Nr. Item no.	Pc.	Unit	Beschreibung Descripción	Description Description	Abm. Dim.	Norm Standard
						Drehmoment Torque	Schmierstoff Lubricant
1	5100028954	1	pc	Bügel Estribo	Shackle Étrier		
2	5100004367	2	pc	Buchse Buje	Bush Boîte		
3	5100028928	2	pc	Buchse Buje	Bush Boîte		

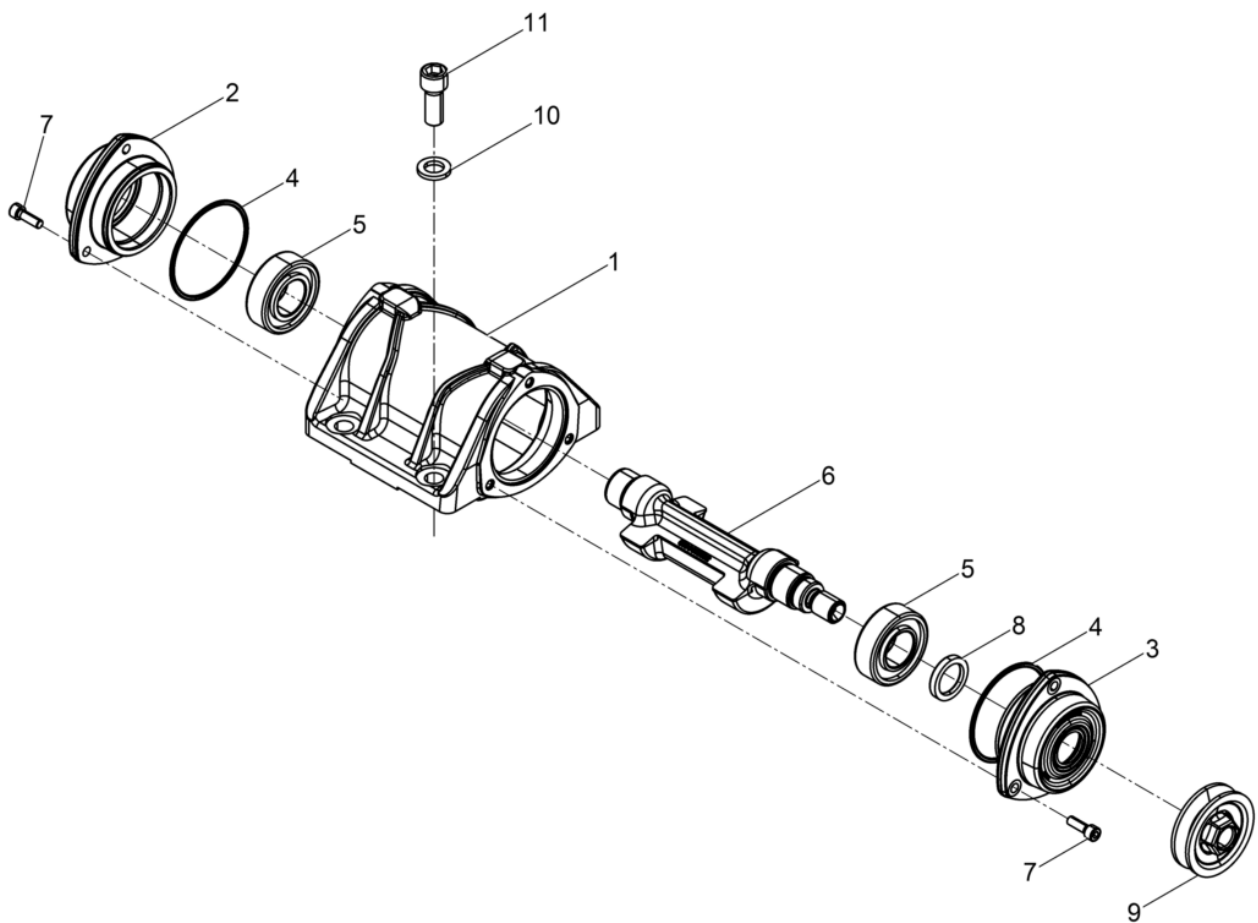

Pos. Item	Artikel Nr. Item no.	Pc.	Unit	Beschreibung Descripción	Description Description	Abm. Dim.	Norm Standard
						Drehmoment Torque	Schmierstoff Lubricant
1	5100016247	1	pc	Erregergehäuse Carcasa del excitador	Exciter housing Carter excitateur		
2	5100022486	1	pc	Lagerschild Placa de cojinete	Bearing bracket Bride palier		
3	5100022485	1	pc	Lagerschild Placa de cojinete	Bearing bracket Bride palier		
4	5100016445	2	pc	O-Ring Anillo-o	O-ring Bague-o	88,49 x 3,53	
5	5100018326	2	pc	Zylinderrollenlager Rodamiento cilíndricos	Cylindrical roller bearing Roulement à rouleaux		
6	5100018133	1	pc	Unwuchtwelle Eje de la masa excéntrica	Eccentric shaft Arbre portant l'excentrique		
7	5100029787	6	pc	Zylinderschraube Tornillo cilíndrico	Cheese head screw Vis à tête cylindrique	22Nm/16ft.lbs	
8	5100016446	1	pc	Wellendichtring Anillo de retén radial	Rotary shaft seal Bague d'étanchéité	B 30 x 42 x 7	
9	5100022460	1	pc	Keilriemenscheibe Polea en v	V-belt pulley Poulie à courroie		
10	5100034545	4	pc	Scheibe Arandela	Washer Rondelle		
11	5100034546	4	pc	Zylinderschraube Tornillo cilíndrico	Cheese head screw Vis à tête cylindrique	210Nm/155ft.lbs	

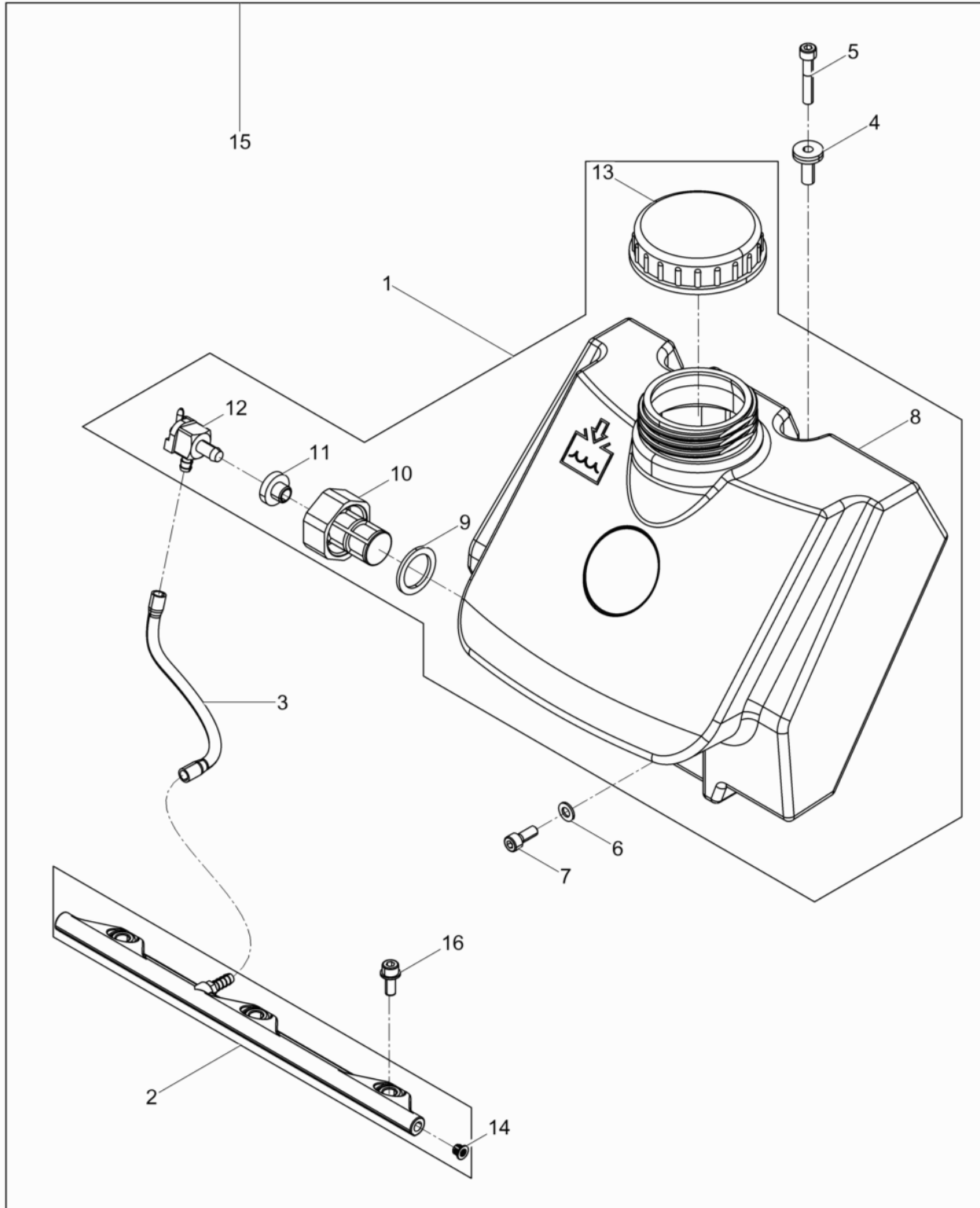

Pos. Item	Artikel Nr. Item no.	Pc.	Unit	Beschreibung Descripción	Description Description	Abm. Dim.	Norm Standard
						Drehmoment Torque	Schmierstoff Lubricant
1	5100028975	1	pc	Wassertank Kpl. Tanque de agua cpl.	Water tank cpl. Reservoir à eau cpl.		
2	5100028977	1	pc	Berieselung Kpl. Systema de riego cpl.	Spinkler system cpl. Installation d'arrosage cpl.		
3	5100028939	1	pc	Wasserschlauch Manguera de agua	Water hose Tuyau d'eau		
4	5100016451	2	pc	Distanzhülse Manguito distanciador	Spacer sleeve Douille d'écartement		
5	5000011538	2	pc	Zylinderschraube Tornillo cilíndrico	Cheese head screw Vis à tête cylindrique	M8 x 45 25Nm/18ft.lbs	ISO4762
6	5000010622	2	pc	Scheibe Arandela	Flat washer Rondelle		
7	5000011543	2	pc	Zylinderschraube Tornillo hueco	Socket head screw Vis à six-pans creux	M8 x 20 24Nm/18ft.lbs	ISO4762
8	5100028976	1	pc	Wassertank Tanque de agua	Watertank Reservoir à eau		
9	5100028934	1	pc	Dichtungsring Anillo sellador	Ring seal Rondelle à étancher		
10	5100028935	1	pc	Wasserfilter Filtro de agua	Water filter Filtre à eau		
11	5000053577	1	pc	Tankbuchse Buje	Tank valve bushing Douille		
12	5100028937	1	pc	Absperrventil Válvula de cierre	Shut-off valve Robinet d'arrêt		
13	5000068351	1	pc	Schraubdeckel Tapa roscable	Screwed cover Couvercle fileté		
14	5100027000	2	pc	Einschraubstopfen Tapón	Plug (threaded) Bouchon		
15	5100028981	1	pc	Berieselung Kpl. Systema de riego cpl.	Sprinkler system cpl Installation d'arrosage cpl.		
16	5100042618	3	pc	Zylinderschraube Tornillo cilíndrico	Cheese head screw Vis à tête cylindrique		

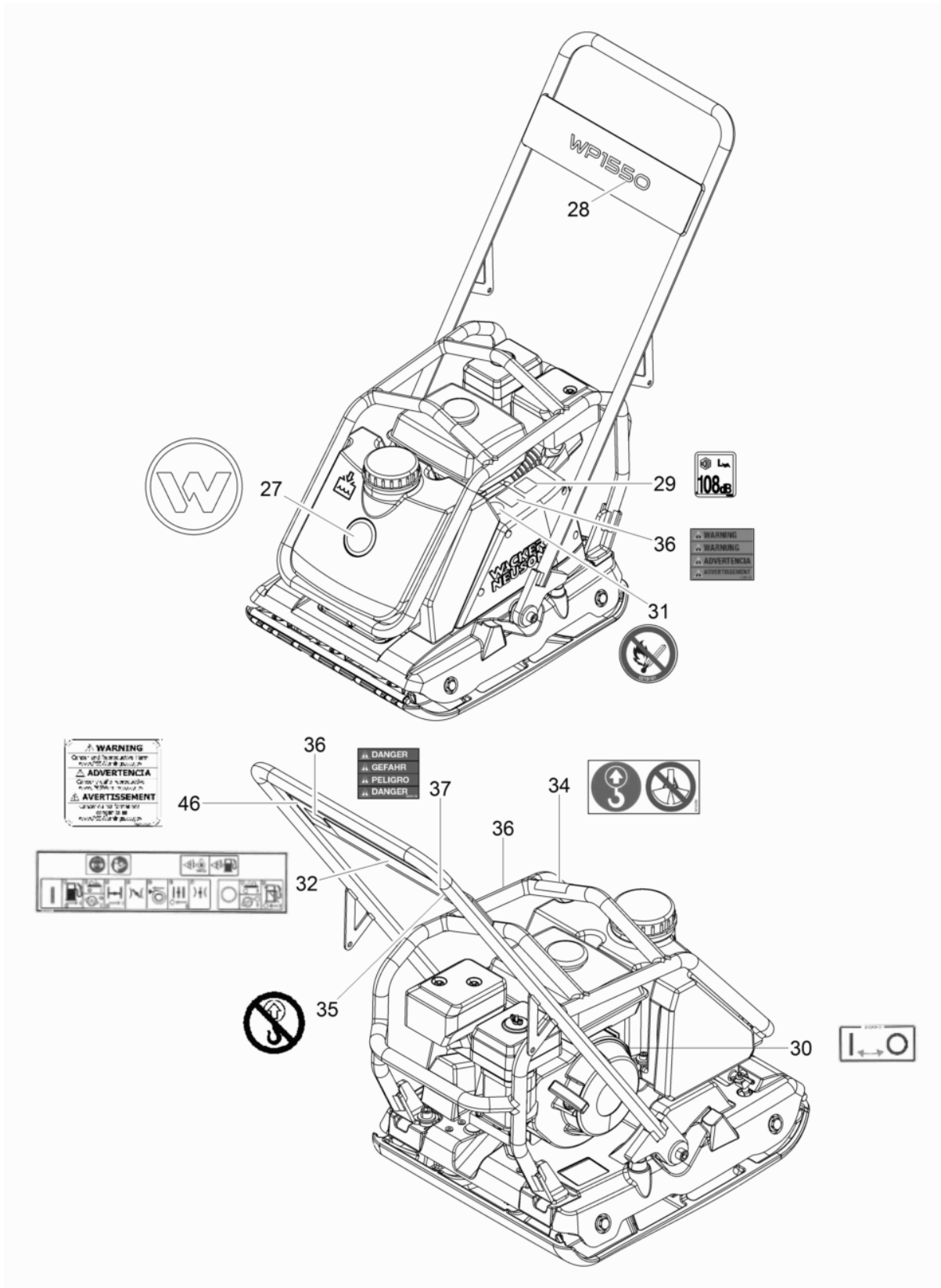

Pos. Item	Artikel Nr. Item no.	Pc.	Unit	Beschreibung Descripción	Description Description	Abm. Dim.	Norm Standard
						Drehmoment Torque	Schmierstoff Lubricant
27	5000222085	1	pc	Aufkleber Symbol Calcomania símbolo	Label symbol Autocollant symbole		
28	5100016454	1	pc	Aufkleber-Typ Tipo etiqueta autoadhesiva	Type label Autocollant de type		
29	5000129784	1	pc	Aufkleber-Schalleistungspegel Etiqueta autoadhesiva-nivel de potencia acúëstica	Decal-sound power level Autocollante-niveau sonore		
30	5100016455	1	pc	Aufkleber (ON-OFF) Calcomania (on-off)	Label (on-off) Autocollant (on-off)		
31	5000219181	1	pc	Aufkleber Calcomanias	Labels Autocollants		
32	5100018423	1	pc	Aufkleber Calcomania	Label Autocollant		
34	5000219260	1	pc	Aufkleber Calcomanias	Labels Autocollants		
35	5000220000	1	pc	Aufkleber-Warnhinweis Calcomanía-indicación	Instruction label Autocollant avec indication		
36	5000219176	3	pc	Aufkleber Calcomanias	Labels Autocollants		
37	5000219178	1	pc	Aufkleber Calcomanias	Labels Autocollants		
46	5100045462	1	pc	Aufkleber Calcomania	Label Autocollant		

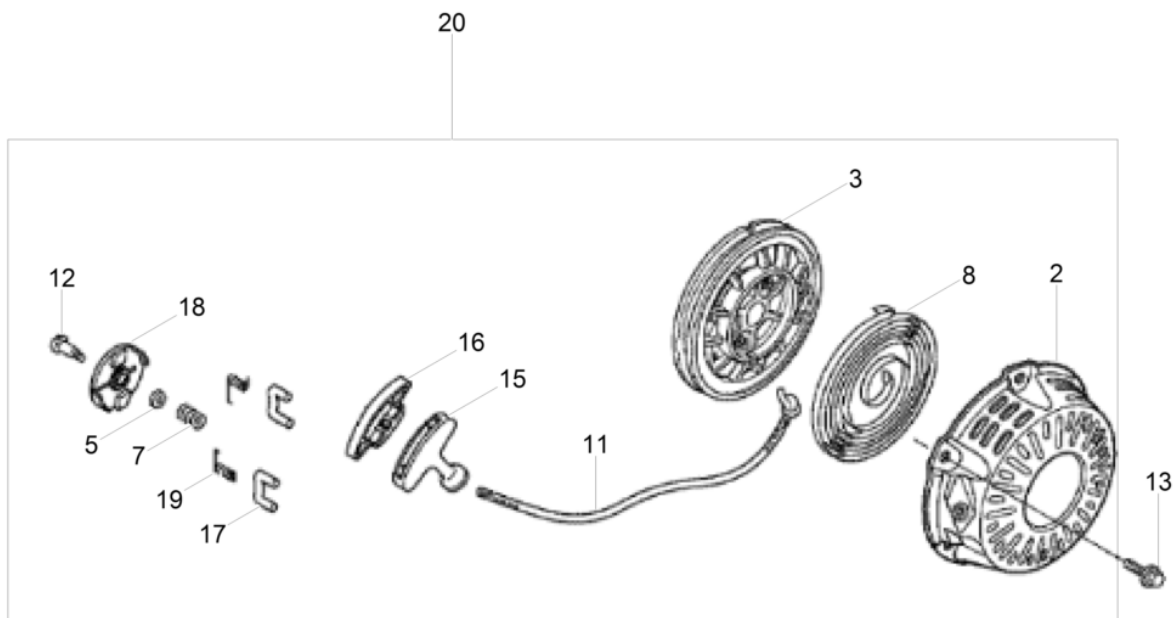

Pos. Item	Artikel Nr. Item no.	Pc.	Unit	Beschreibung Descripción	Description Description	Abm. Dim.	Norm Standard
						Drehmoment Torque	Schmierstoff Lubricant
2	5100005307	1	pc	Gehäuse Kpl. (Schwarz) Carcasa cpl. (negro)	Housing cpl. (black) Carter cpl. (noir)		
2	5100005369	1	pc	Gehäuse Kpl. (Rot) Carcasa cpl. (rojo)	Housing cpl. (red) Enveloppe cpl. (rouge)		
3	5100036077	1	pc	Seilzugscheibe Polea	Starter pulley Poulie de démarrage		
5	5000160748	1	pc	Reibplatte Placa de fricción	Friction plate Plaque à friction		
7	5000160747	1	pc	Reibfeder Resorte de fricción	Friction spring Ressort à friction		
8	5000081777	1	pc	Feder Resorte	Spring Ressort		
11	5000081781	1	pc	Starterseil Cuerda	Rope Corde		
12	5000207991	1	pc	Schraube Tornillo	Screw Vis		
13	5000081750	3	pc	Schraube Tornillo	Screw Vis	M6 x 8	
15	5100005309	1	pc	Startergriff US Empuñadura del starter us	Starter handle us Poignée du lanceur us		
15	5100005413	1	pc	Startergriff Empuñadura del starter	Starter handle Poignée du lanceur		
16	5100005310	1	pc	Abdeckung Cubierta	Covering Couverture		
17	5100036078	2	pc	Sperrklinke Trinquete	Ratchet Cliquet		
18	5100036079	1	pc	Führung Guia	Guide Guide		
19	5100036230	2	pc	Rückholfeder Resorte de retorno	Return spring Ressort de rappel		
20	5100039021	1	pc	Reversierstarter Kpl. Starter reversible	Recoil starter Démarrreur réversible		
20	5100047597	1	pc	Reversierstarter Kpl. Starter reversible cpl.	Recoil starter cpl. Démarrreur réversible cpl.		

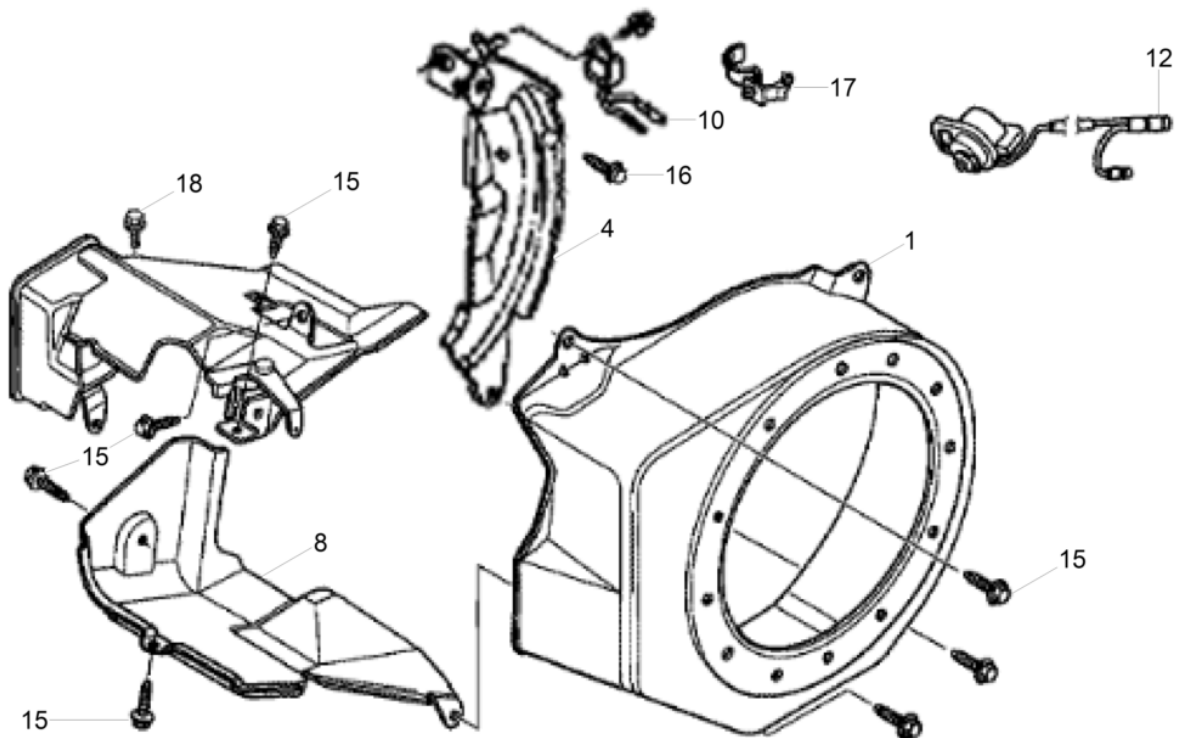

Pos. Item	Artikel Nr. Item no.	Pc.	Unit	Beschreibung Descripción	Description Description	Abm. Dim.	Norm Standard
						Drehmoment Torque	Schmierstoff Lubricant
1	5100005354	1	pc	Gebeläseabdeckung Kpl. Tapa de ventilador cpl.	Fan hood cpl. Couvercle du sys. de vent. cpl		
1	5100005354	1	pc	Gebeläseabdeckung Kpl. Tapa de ventilador cpl.	Fan hood cpl. Couvercle du sys. de vent. cpl		
4	5100005312	1	pc	Abdeckung Cubierta	Covering Couverture		
8	5100047598	1	pc	Luftführungsteil Conducción de aire	Air ducting Carter ventilation		
10	5100005313	1	pc	Ölsensor Alerta de aceite	Oil sensor Alerte d'huile		
12	5100047599	1	pc	Motorabschalter Kpl. Dispositivo de parado cpl.	Engine stop device cpl. Dispositif d'arret cpl.		
15	5000053990	6	pc	Schraube Tornillo	Screw Vis	M6 x 12 10Nm/7ft.lbs	
16	5000071055	1	pc	Schraube Tornillo	Screw Vis	M6 x 20 10Nm/7ft.lbs	
17	5000151700	1	pc	Schelle Abrazadera	Clamp Attache		
18	5000081750	1	pc	Schraube Tornillo	Screw Vis	M6 x 8	

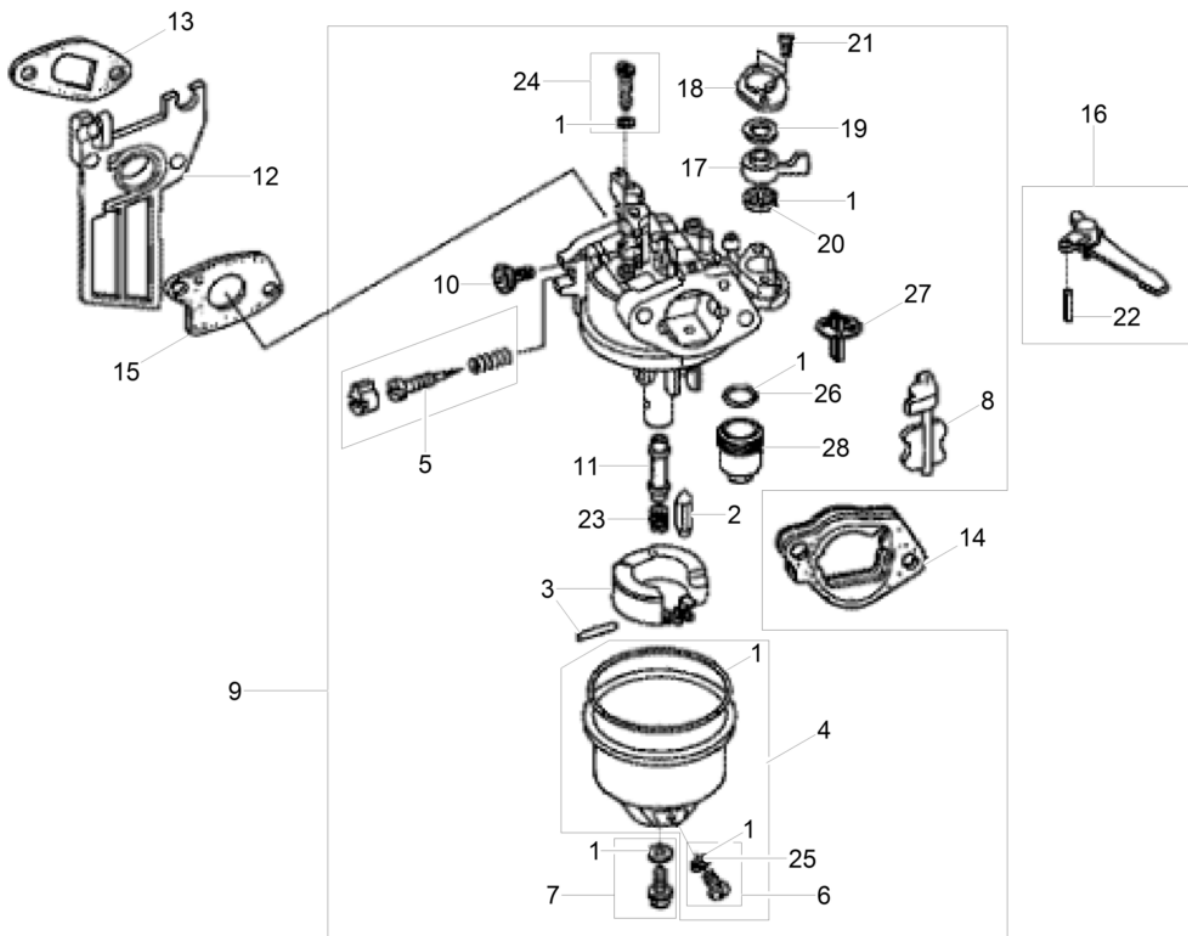

Pos. Item	Artikel Nr. Item no.	Pc.	Unit	Beschreibung Descripción	Description Description	Abm. Dim.	Norm Standard
						Drehmoment Torque	Schmierstoff Lubricant
1	5000072781	1	pc	Dichtungssatz Juego de juntas	Set-gaskets Jeu de joints		
2	5000071022	1	pc	Schwimmernadel Kpl. Válvula de flotador	Set-float valve Pointeau du carburateur		
3	5000209764	1	pc	Schwimmer Kpl. Juego de flotador	Set-carburetor float Jeu de flotteur		
4	5100005314	1	pc	Schwimmergehäuse Cámara de flotador	Float housing Cuve à niveau constant		
5	5000089286	1	pc	Gewindestift Tornillo	Setscrew Vis		
6	5200000430	1	pc	Schraube Mit Scheibe Tornillo con arandela	Screw w/washer Vis avec rondelle		
7	5200000431	1	pc	Schraube Mit Scheibe Tornillo con arandela	Screw w/washer Vis avec rondelle		
8	5100005415	1	pc	Staterklappe Válvula de mariposa	Starter flap Volet de démarrage		
9	5100048120	1	pc	Vergaser Kpl. Carburador cpl.	Carburetor cpl. Carburateur cpl.		
10	5000071018	1	pc	Anschlagschraube Tornillo de tope	Throttle stop screw Vis		
11	5100048121	1	pc	Hauptdüse Gicleur principal	Main jet Gicleur prinzipal		
12	5100005416	1	pc	Isolator Aislador	Isolator Isolateur		
13	5000082009	1	pc	Dichtung Junta	Gasket Joint		
14	5000071015	1	pc	Distanzstück Espaciador	Spacer Pièce d'écartement		
15	5000081762	1	pc	Dichtung Junta	Gasket Joint		
16	5000071013	1	pc	Chokehebel Palanca estranguladora	Choke control lever Levier d'étrangleur		
17	5000150266	1	pc	Kraftstoffhahn Palanca	Fuel valve lever Levier		
18	5000073269	1	pc	Platte Placa	Plate Plaque		
19	5000073270	1	pc	Federscheibe Arandela elástica	Spring washer Rondelle à ressort		
20	5000073272	1	pc	Dichtung Junta	Gasket Joint		
21	5100005317	2	pc	Kegelkopfschraube 3X6 Tornillo	Screw Vis	3x6	
22	5000071014	1	pc	Stift Pasador	Pin Goupille	2 x 12	
23	5000162703	1	pc	Hauptdüse Gicleur principal	Main jet Gicleur prinzipal	72	
24	5000084654	1	pc	Leerlaufdüsensatz Juego-chicler piloto	Set-pilot jet Jeu-gicleur de ralenti	40	
25	5100036241	1	pc	Scheibe Disco	Disc Disque		
26	5000125839	1	pc	O-Ring Anillo-o	O-ring Joint torique		
27	5100000396	1	pc	Filter Filtro	Filter Filtre		
28	5000071023	1	pc	Kraftstofffilter Filtro de combustible	Fuel filter Filtre à carburant		



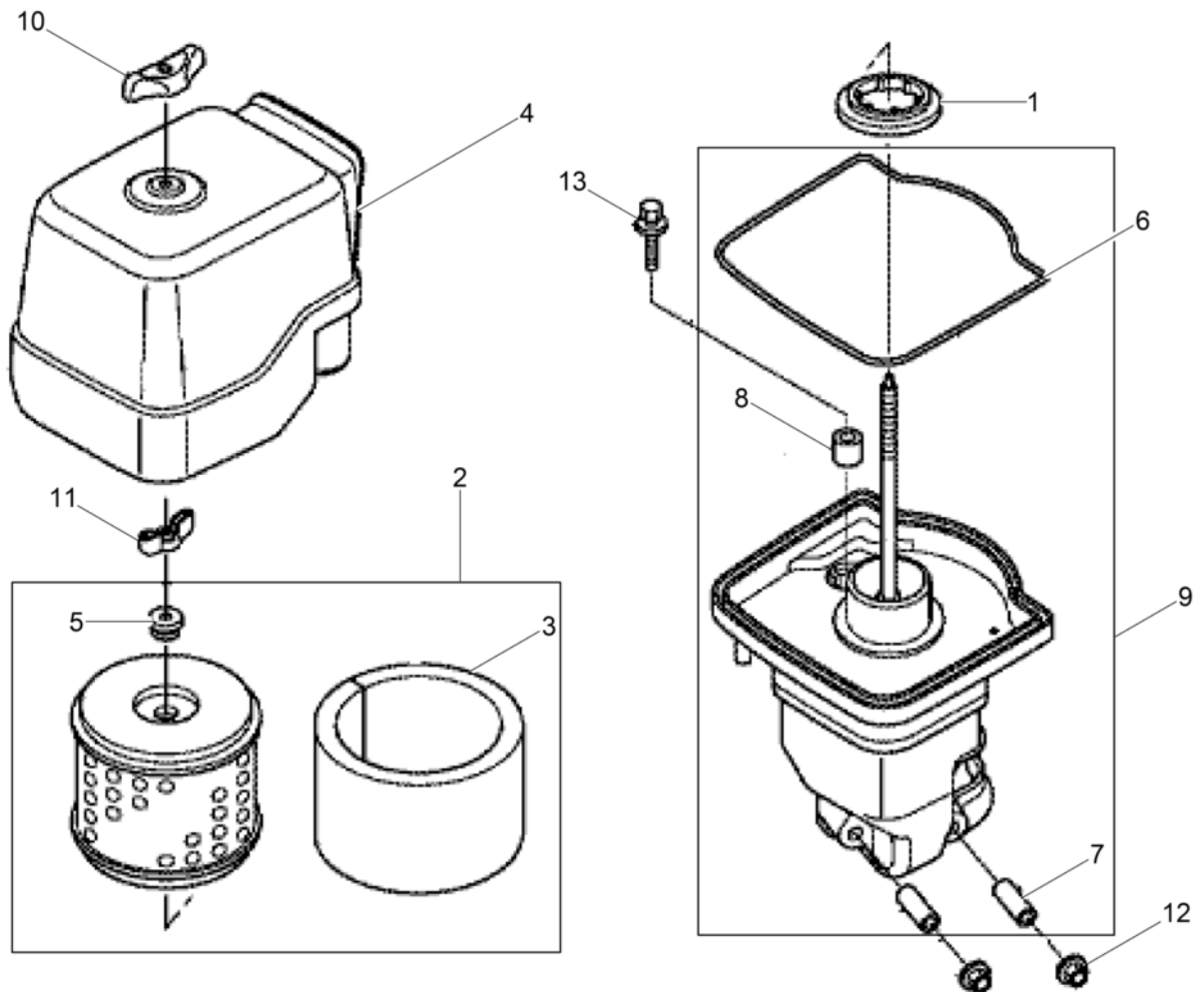

Pos. Item	Artikel Nr. Item no.	Pc.	Unit	Beschreibung Descripción	Description Description	Abm. Dim.	Norm Standard
						Drehmoment Torque	Schmierstoff Lubricant
1	5000071032	1	pc	Dichtung Junta	Gasket Joint		
2	5100039024	1	pc	Luftfilter Kpl. Filtro de aire cpl.	Air filter cpl. Filtre à air cpl.		
3	5100039025	1	pc	Luftfilter Aussen Filtro de aire exterior	Air filter external Filtre à air l'extérieur		
4	5100039026	1	pc	Luftfilterdeckel Tapa filtro de aire	Air filter cover Couvercle filtre à air		
5	5000072343	1	pc	Tülle Ojal	Grommet Passe-fil		
6	5100039027	1	pc	Dichtung Junta	Gasket Joint		
7	5000081746	2	pc	Hülse Collar	Sleeve Douille		
8	5000126941	1	pc	Hülse Collar	Sleeve Douille		
9	5100039028	1	pc	Filterkonsole Kpl. Consola del filtro cpl.	Filter bracket cpl. Console de filtre cpl.		
10	5100031333	1	pc	Flügelmutter Tuerca mariposa	Wing nut Écrou papillon		
11	5000071621	1	pc	Flügelmutter Tuerca mariposa	Wing nut Écrou papillon	M6	
12	5000071056	2	pc	Mutter Tuerca	Nut Écrou	M6	
13	5100003499	1	pc	Flanschschraube 6X20 Tornillo de brida	Flange screw Vis de bride	6x20	

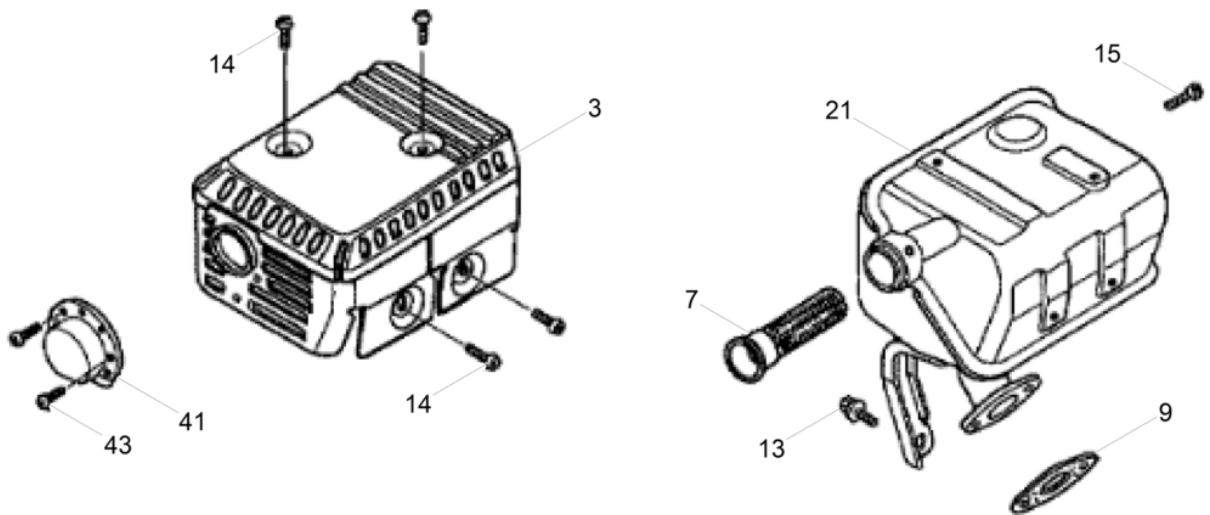

Pos. Item	Artikel Nr. Item no.	Pc.	Unit	Beschreibung Descripción	Description Description	Abm. Dim.	Norm Standard
						Drehmoment Torque	Schmierstoff Lubricant
1	5100048122	1	pc	Schalldämpfer Kpl. Silenciador cpl.	Muffler cpl. Silencieux cpl.		
3	5100005320	1	pc	Schutz Kpl. Protección cpl.	Protection cpl. Protection cpl.		
7	5000071075	1	pc	Funkenfänger Parachispas	Spark arrester Pare-étincelles		
7	5100005321	1	pc	Funkenfänger Parachispas	Spark arrester Pare-étincelles		
9	5000216516	1	pc	Dichtung Junta de estanqueidad	Gasket Garniture		
13	5000072773	1	pc	Schraube Tornillo	Screw Vis	M6 x 13 10Nm/7ft.lbs	
14	5000071070	4	pc	Schraube Tornillo	Screw Vis	M5 x 8	
15	5000217463	1	pc	Schraube Tornillo	Screw Vis	M4x6	
19	5100003492	2	pc	Sechskantmutter M8 Tuerca hexagonal	Hexagon nut Écrou hexagonal	M8	
21	5100005322	1	pc	Schalldämpfer Kpl. Silenciador cpl.	Muffler cpl. Silencieux cpl.		
41	5000107072	1	pc	Auspuffdeflektor Deflector de escape	Exhaustdeflector Échappement déflecteur		
43	5000150916	2	pc	Schraube Tornillo	Screw Vis	M4x6	

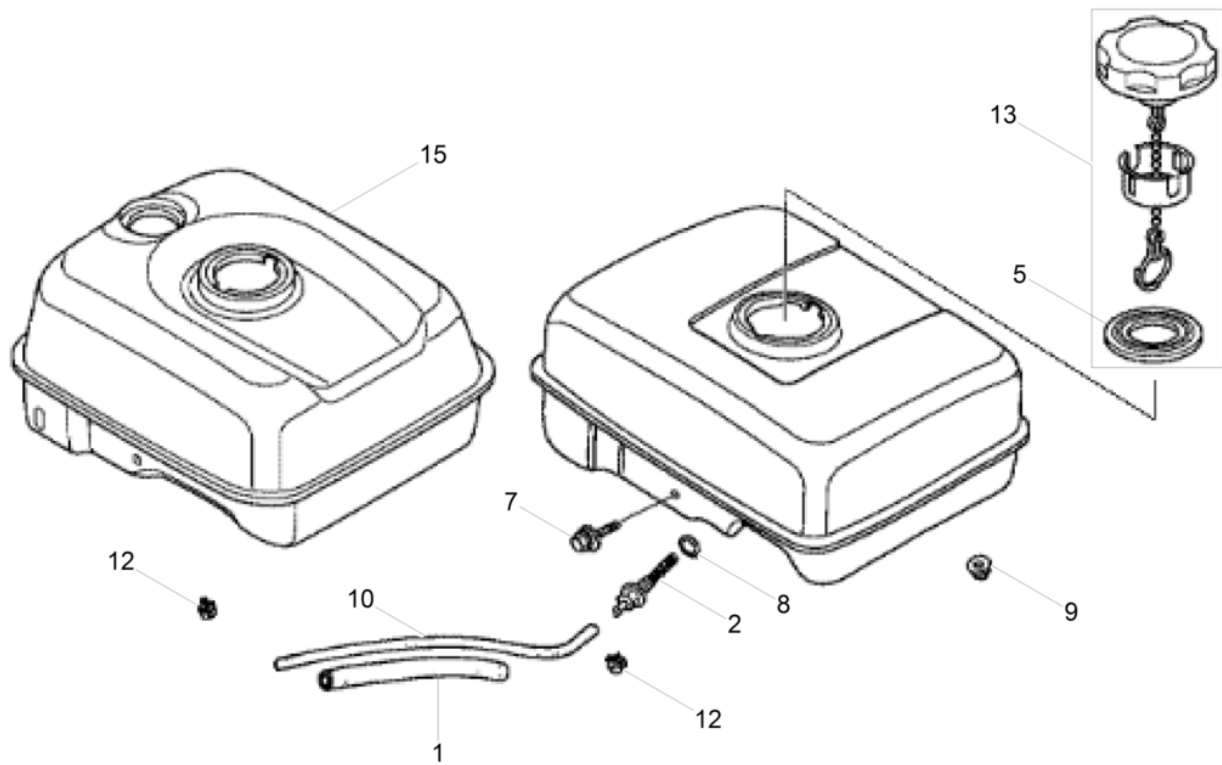

Pos. Item	Artikel Nr. Item no.	Pc.	Unit	Beschreibung Descripción	Description Description	Abm. Dim.	Norm Standard
						Drehmoment Torque	Schmierstoff Lubricant
1	5000081764	1	pc	Schlauchstück Manguera	Protective hose Tuyau		
2	5100000395	1	pc	Verbindungsstück Conexión	Connection Connexion		
5	5000209770	1	pc	Dichtung Junta de estanqueidad	Gasket Garniture		
7	5000209771	1	pc	Flanschbolzen Tornillo de perno	Flange bolt Vis de boulon	6x29	
8	5000208616	1	pc	O-Ring Anillo-o	O-ring Joint torique	14M	
9	5000071056	2	pc	Mutter Tuerca	Nut Ecrou	M6	
10	5100005325	1	pc	Kraftstoffschlauch 4,5X145 Manguera de combustible	Fuel hose Tuyau à essence	4,5x145	
12	5000208617	2	pc	Rohrschelle Abrazadera	Clamp Agrafe		
13	5100005356	1	pc	Tankdeckel Kpl. Tapa de tanque cpl.	Tank cover cpl. Couvercle du reservoir cpl.		
15	5100005323	1	pc	Kraftstofftank Kpl. Tanque de combustible cpl.	Fuel tank cpl. Réservoir de carburant cpl.		

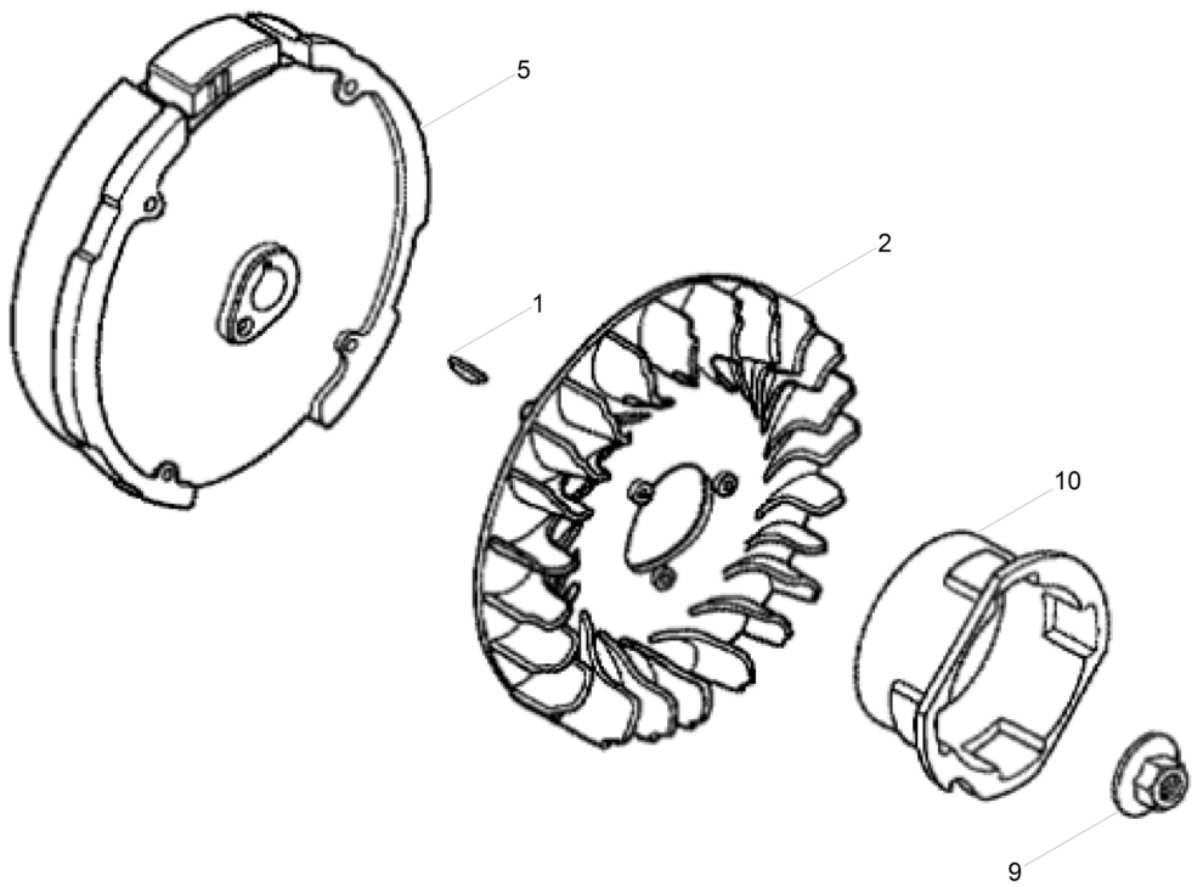

Pos. Item	Artikel Nr. Item no.	Pc.	Unit	Beschreibung Descripción	Description Description	Abm. Dim.	Norm Standard
						Drehmoment Torque	Schmierstoff Lubricant
1	5000068967	1	pc	Keil Chaveta woodruff	Woodruff key Clavette woodruff	25 x 18	
2	5000071652	1	pc	Lüfterrad Ventilador	Fan Ventilateur		
5	5100005422	1	pc	Schwungrad Kpl. Volante cpl.	Fly wheel cpl. Volant cpl.		
9	5000162686	1	pc	Mutter Tuerca	Nut Écrou	M14	
10	5100048123	1	pc	Anlasserriemenscheibe Starter polea	Starter v-belt pulley Démarreur poulie		

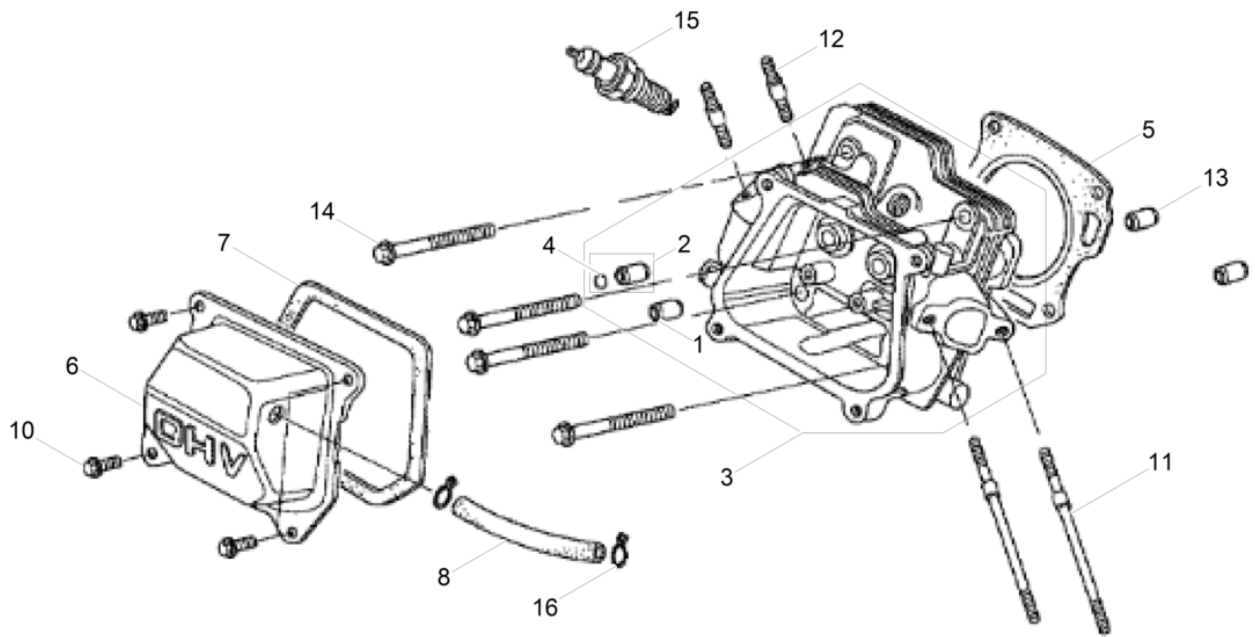

Pos. Item	Artikel Nr. Item no.	Pc.	Unit	Beschreibung Descripción	Description Description	Abm. Dim.	Norm Standard
						Drehmoment Torque	Schmierstoff Lubricant
1	5000070945	1	pc	Ventilführung Guía de válvula	Valve guide Guide de soupape		
2	5000070944	1	pc	Ventilführung Guía de válvula	Valve guide Guide de soupape		
3	5100005423	1	pc	Zylinderkopf Kpl. Culata cpl.	Cylinder head cpl. Culasse cpl.		
4	5000081744	1	pc	Sicherungsring Anillo de retención	Retaining ring Bague d'arrêt		
5	5100005329	1	pc	Zylinderkopfdichtung Junta de culata del cilindro	Cylinder head gasket Joint de culasse de cylindre		
6	5100005330	1	pc	Zylinderkopfdeckel Kpl. Tapa del cilindro cpl.	Cylinder head cover cpl. Couvercle supérieur cpl.		
7	5000070942	1	pc	Dichtung Junta	Gasket Joint		
8	5000217757	1	pc	Entlüftungsrohr Tube reniflard	Breather tube Tubo respiradero		
10	5000053990	4	pc	Schraube Tornillo	Screw Vis	M6 x 12 10Nm/7ft.lbs	
11	5000073263	2	pc	Gewindebolzen Perno prisionero	Stud Boulon	M6 x 109	
12	5000070948	2	pc	Gewindebolzen Perno prisionero	Stud Boulon	M8 x 32	
13	5000070950	2	pc	Passtift Espiga	Dowel pin Cheville		
14	5000213398	4	pc	Flanschschraube Tornillo de brida	Flange screw Vis de bride	M 8x60	
15	5000207671	1	pc	Zündkerze Bujía	Spark plug Bougie		
16	5000217758	2	pc	Befestigung Clip	Clip Clip		

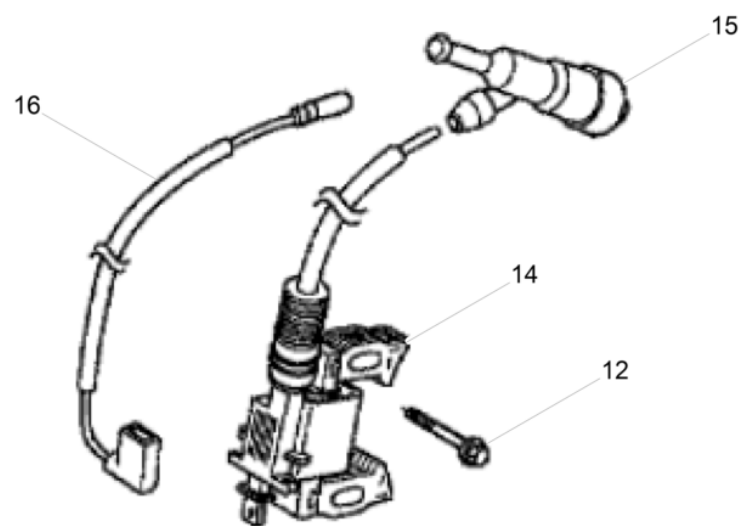

Pos. Item	Artikel Nr. Item no.	Pc.	Unit	Beschreibung Descripción	Description Description	Abm. Dim.	Norm Standard
						Drehmoment Torque	Schmierstoff Lubricant
12	5000081737	2	pc	Schraube Tornillo	Screw Vis	M6 x 25	
14	5100003455	1	pc	Zündspule Kpl. Bobina de encendido cpl.	Ignition coil cpl. Bobine d'allumage cpl.		
15	5100031334	1	pc	Zündkerzenstecker Enchufe de bujía	Spark plug terminal cap Porte bougies		
16	5100031335	1	pc	Kabel Cable	Cable Câble		

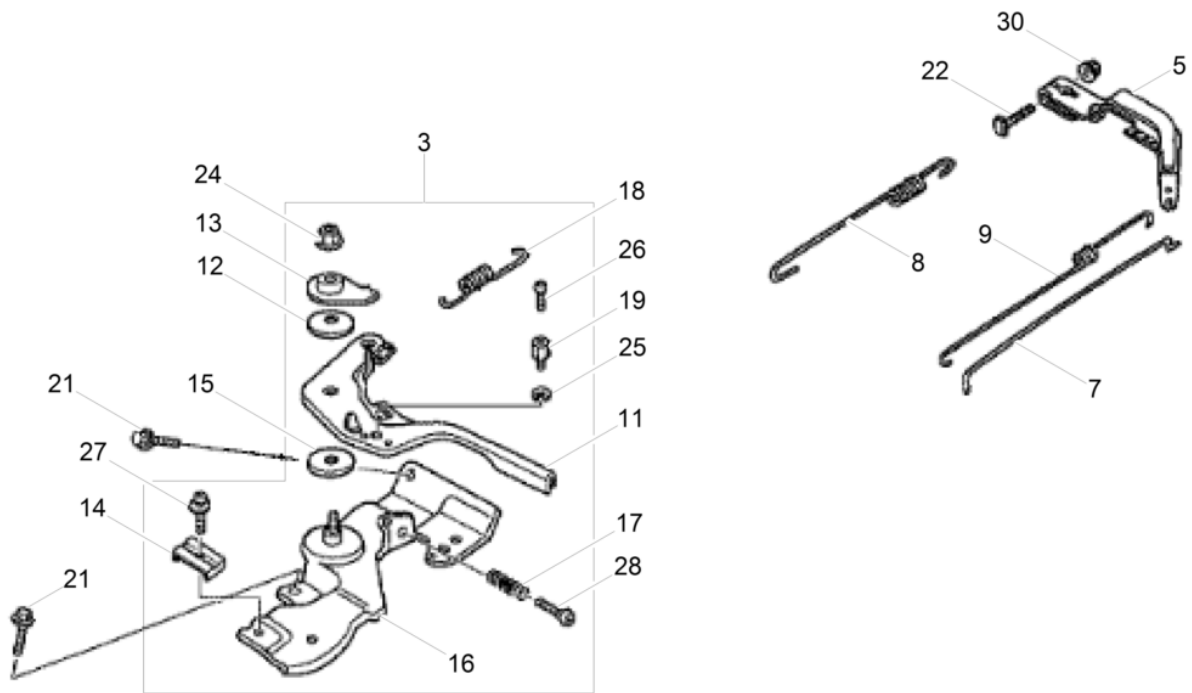

Pos. Item	Artikel Nr. Item no.	Pc.	Unit	Beschreibung Descripción	Description Description	Abm. Dim.	Norm Standard
						Drehmoment Torque	Schmierstoff Lubricant
3	5100039031	1	pc	Regler Kpl. Regulador cpl.	Governor cpl. Régulateur cpl.		
3	5100048124	1	pc	Drehzahlregler Kpl. Controlador de velocidad cpl.	Speed control module cpl. Régulateur de vitesse cpl.		
5	5100005425	1	pc	Regulierhebel Palanca reguladora	Governor lever Lever régulateur		
7	5100005332	1	pc	Reglerstange Varillaje de regulación	Governor rod Tige de régulateur		
8	5100005426	1	pc	Feder Resorte	Spring Ressort		
9	5100005427	1	pc	Rückholfeder Resorte de retorno	Return spring Ressort de rappel		
11	5100005333	1	pc	Reglerhebel Palanca de regulador	Governor lever Lever régulateur		
12	5000071058	1	pc	Feder Resorte	Spring Ressort		
13	5000071057	1	pc	Scheibe Arandela	Washer Rondelle		
14	5000071062	1	pc	Klemme Soporte cable	Cable holder Attache		
15	5000071064	1	pc	Distanzstück Espaciador	Spacer Pièce d'écartement		
16	5100039032	1	pc	Reglerplatte Placa del regulador	Regulating plate Plaque de régulateur		
17	5000054088	1	pc	Feder Resorte de ajuste	Adjusting spring Ressort d'ajustage		
18	5000071667	1	pc	Feder Resorte	Spring Ressort		
19	5000151819	1	pc	Klemmstück Pieza de fijación	Clamping piece Pièce de serrage		
21	5000053990	2	pc	Schraube Tornillo	Screw Vis	M6 x 12 10Nm/7ft.lbs	
22	5100000451	1	pc	Schraube Tornillo	Screw Vis		
24	5000072782	1	pc	Sicherungsmutter Contratuercas	Locknut Contre-écrou	M6	
25	5000151823	1	pc	Sicherungsscheibe Arandela de seguridad	Lock washer Rondelle d'arrêt	5	
26	5000151824	1	pc	Schraube Tornillo	Screw Vis	M 4x6	
27	5000110112	1	pc	Schraube Tornillo	Screw Vis	5 x 16	
28	5000081990	1	pc	Schraube Tornillo	Screw Vis	M5 x 25	
30	5000071056	1	pc	Mutter Tuerca	Nut Ecrou	M6	

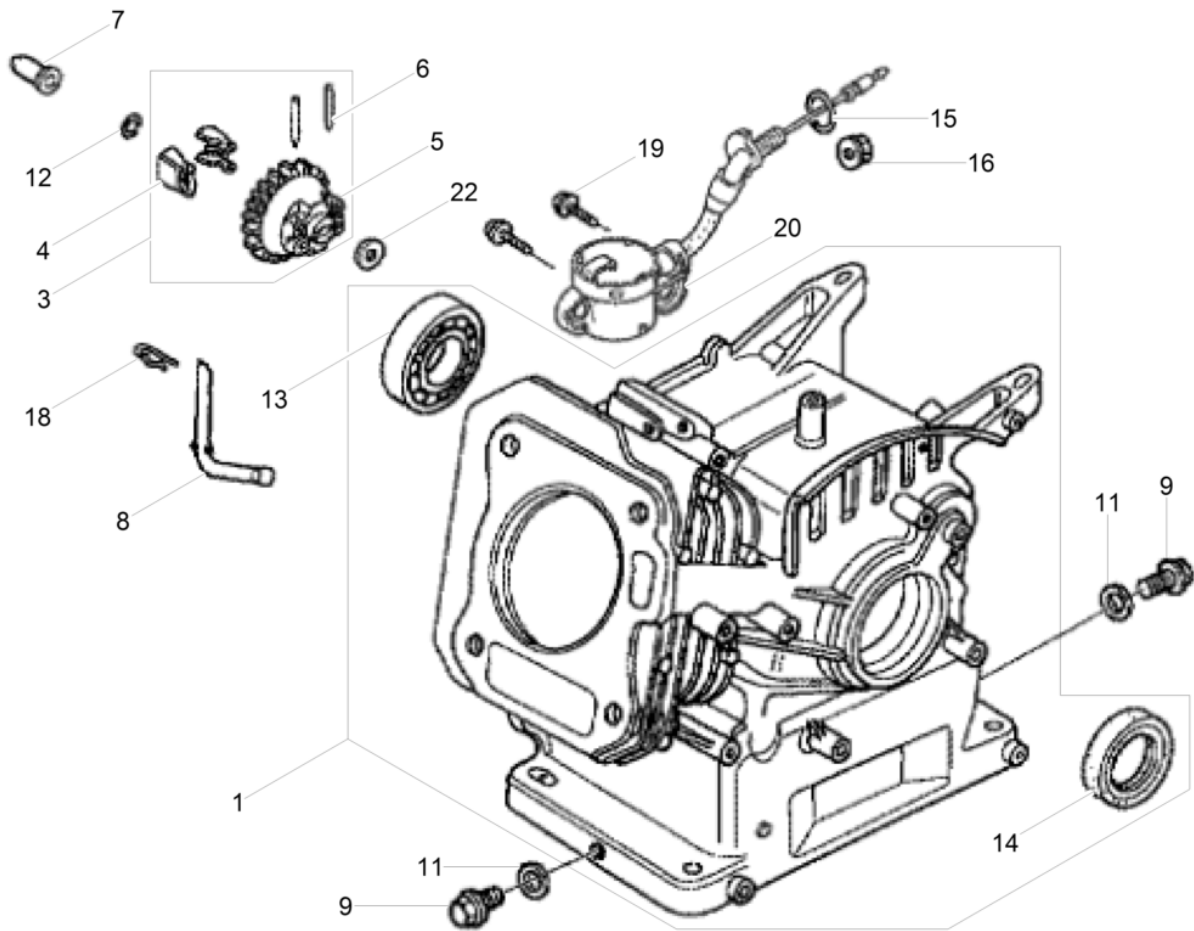

Pos. Item	Artikel Nr. Item no.	Pc.	Unit	Beschreibung Descripción	Description Description	Abm. Dim.	Norm Standard
						Drehmoment Torque	Schmierstoff Lubricant
1	5100005428	1	pc	Zylindergehäuse Kpl. Carcasa de cilindro cpl.	Cylinder housing cpl. Carter cylindre cpl.		
3	5100005429	1	pc	Regler Kpl. Regulador cpl.	Governor cpl. Régulateur cpl.		
4	5100005430	2	pc	Gewicht Peso	Weight Poids		
5	5100005431	1	pc	Halter Soporte	Bracket Équerre		
6	5000156689	2	pc	Stift Espiga	Pin Goupille		
7	5000406670	1	pc	Gleitstück Manguito	Slider Douille		
7	5100005432	1	pc	Reglerstift Pasador del regulador	Governor pin Pointe de regulateur		
8	5100005433	1	pc	Regler Regulador	Governor Régulateur		
9	5000070964	2	pc	Verschlusschraube Tapón roscado	Plug (threaded) Bouchon		
11	5000070963	2	pc	Scheibe Arandela	Washer Rondelle		
12	5000081615	1	pc	Sicherungsring Anillo de retención	Retaining ring Bague d'arrêt		
13	5100003485	1	pc	Radialkugellager 6205 Rodamiento de bolas	Grooved ball bearing Roulement à billes		
14	5100039035	1	pc	Simmerring Anillo sellador	Ring seal Rondelle à étancher		
15	5000208616	1	pc	O-Ring Anillo-o	O-ring Joint torique	14M	
16	5000072332	1	pc	Flanschmutter Tuerca de reborde	Flange nut Erou de bride	M10	
18	5000054033	1	pc	Stift Pasador	Pin Goupille		
19	5100003498	2	pc	Flanschschraube 6X12 Tornillo de brida	Flange screw Vis de bride	6x12	
21	5000216513	1	pc	Ölwarnschalter Modulo-interruptor	Oil alert switch cpl. Module-contacteur		
22	5000071639	1	pc	Scheibe Arandela	Washer Rondelle	6M	

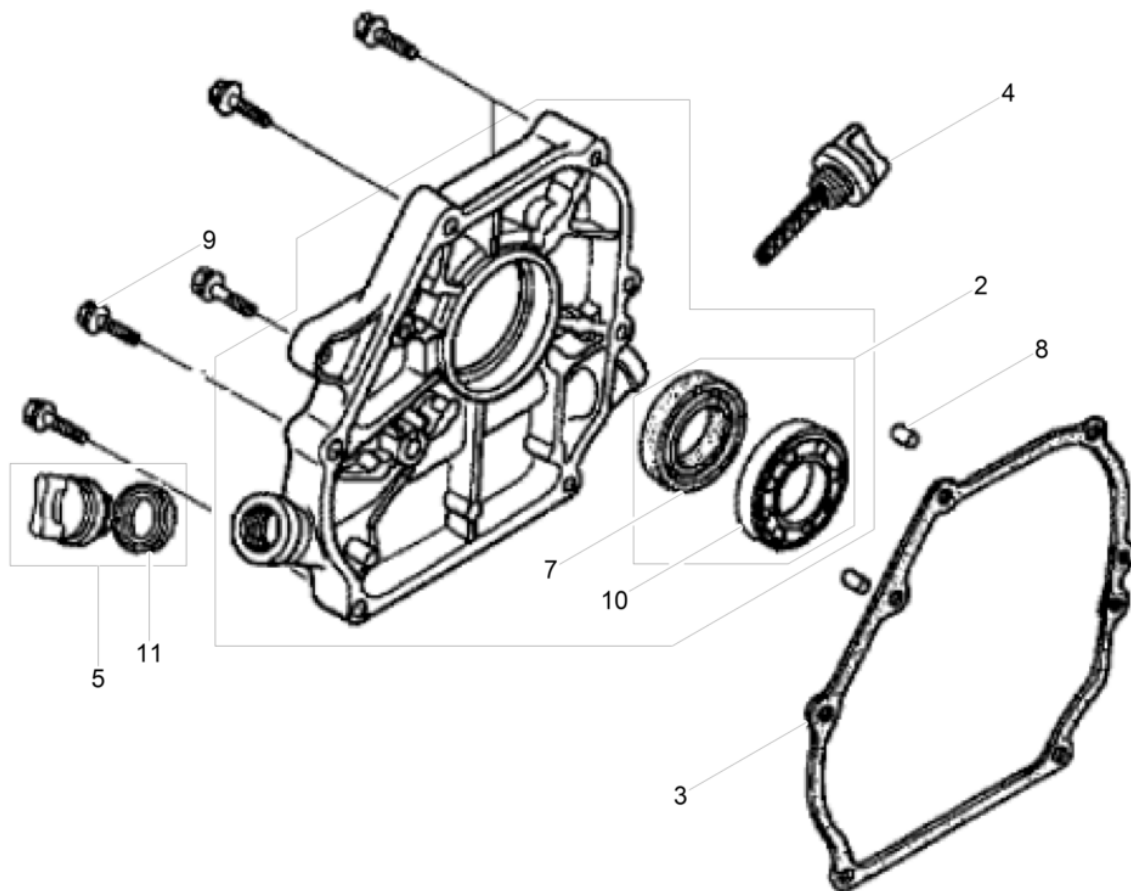

Pos. Item	Artikel Nr. Item no.	Pc.	Unit	Beschreibung Descripción	Description Description	Abm. Dim.	Norm Standard
						Drehmoment Torque	Schmierstoff Lubricant
2	5100005434	1	pc	Kurbelgehäusedeckel Kpl. Tapa del cárter cpl.	Crankcase cover cpl. Couvercle de carter cpl.		
3	5100009314	1	pc	Dichtung Junta	Gasket Joint		
4	5000162645	1	pc	Peilstab Kpl. Indicador del nivel de aceite compl.	Dipstick assembly Réglette-jauge compl.		
5	5100031607	1	pc	Kappe-Ölfüller Llenador de aceite	Oil filler cap Remplisseur d'huile		
7	5000053983	1	pc	Wellendichtring Sello del eje	Shaft seal Bague d'étanchéité	25 x 41 x 6	
8	5000053995	2	pc	Passtift Espiga	Dowel pin Cheville	A8 x 14	
9	5100003504	6	pc	Flanschschraube 8X32 Tornillo de brida	Flange screw Vis de bride	8x32	
10	5100003510	1	pc	Radialkugellager 6205 Rodamiento de bolas	Grooved ball bearing Roulement à billes		
11	5000162647	1	pc	Dichtung Junta de estanqueidad	Gasket Garniture		

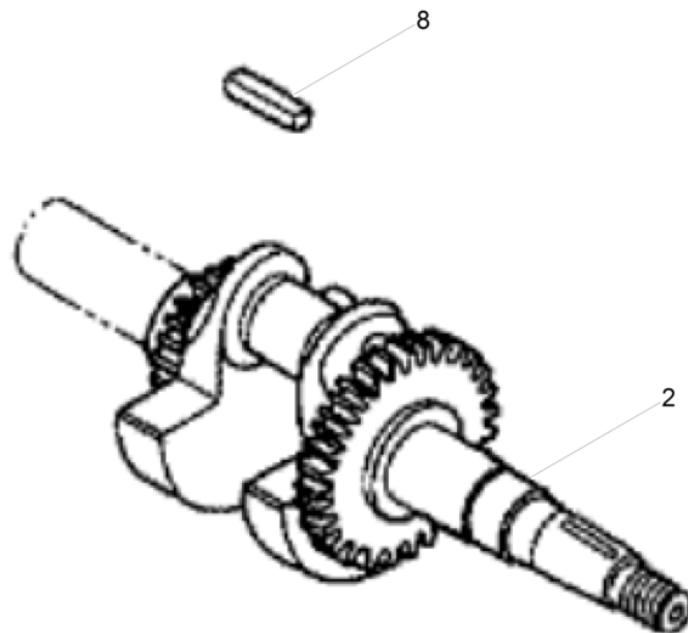

Pos. Item	Artikel Nr. Item no.	Pc.	Unit	Beschreibung Descripción	Description Description	Abm. Dim.	Norm Standard
						Drehmoment Torque	Schmierstoff Lubricant
2	5100005359	1	pc	Kurbelwelle Kpl. Cigueñal cpl.	Crankshaft cpl. Vilebrequin cpl.		
8	5000070999	1	pc	Passfeder Chaveta	Fitting key Clavette	4,78 x 38	

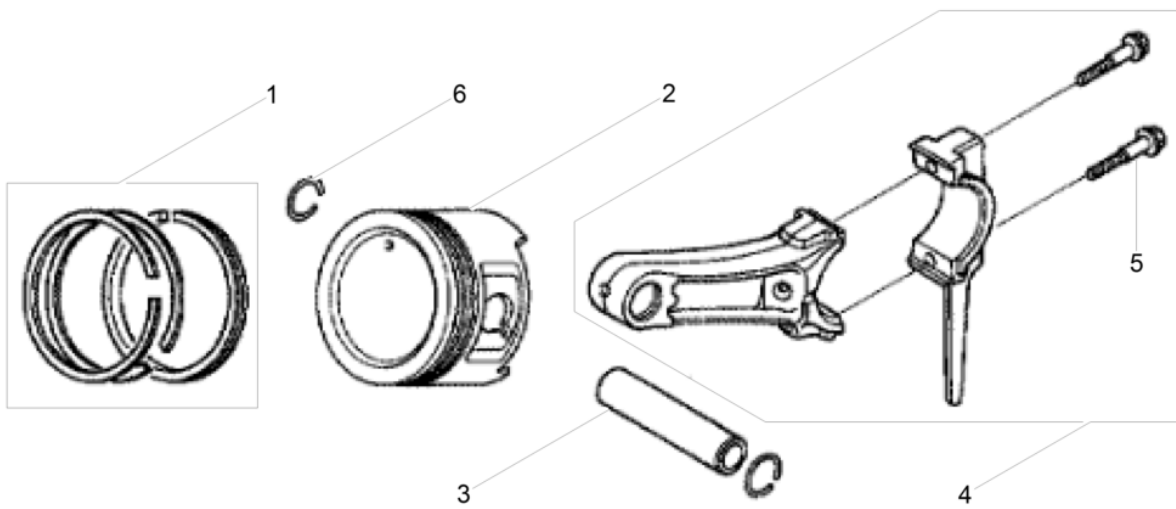

Pos. Item	Artikel Nr. Item no.	Pc.	Unit	Beschreibung Descripción	Description Description	Abm. Dim.	Norm Standard
						Drehmoment Torque	Schmierstoff Lubricant
1	5000217531	1	pc	Kolbenringsatz Juego de aros de pistón	Set of piston rings Jeu de segments de piston	0,25	
1	5000217532	1	pc	Kolbenringsatz Juego de aros de pistón	Set of piston rings Jeu de segments de piston	0,5	
1	5100005435	1	pc	Kolbenringsatz Juego de aros de pistón	Set of piston rings Jeu de segments de piston		
2	5100005436	1	pc	Kolben Pistón	Piston Piston		
2	5100019661	1	pc	Kolben Pistón	Piston Piston	0,25	
2	5100019662	1	pc	Kolben Pistón	Piston Piston	0,50	
3	5100005348	1	pc	Kolbenbolzen Perno de pistón	Piston pin Axe de piston		
4	5000406679	1	pc	Pleuel Kpl. Biela compl.	Connecting rod cpl. Bielle compl.		
5	5100005438	2	pc	Schraube Tornillo	Screw Vis	6x34,4	
6	5000081994	2	pc	Drahtsprengring Anillo de retención	Retaining ring Anneau de retenue		

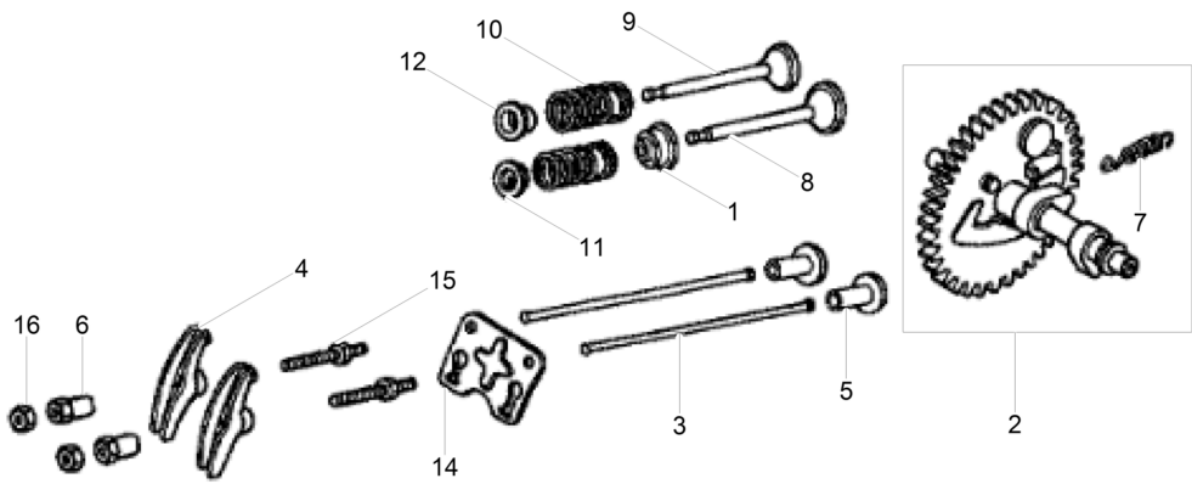

Pos. Item	Artikel Nr. Item no.	Pc.	Unit	Beschreibung Descripción	Description Description	Abm. Dim.	Norm Standard
						Drehmoment Torque	Schmierstoff Lubricant
1	5100005349	1	pc	Dichtung Junta	Gasket Joint		
2	5100005439	1	pc	Nockenwelle Kpl. Arbol de levas cpl.	Camshaft cpl. Arbre à cames cpl.		
3	5100005440	2	pc	Schubstange Varilla de empuje	Push rod Pousoir		
4	5000070986	2	pc	Kipphebel Balancín	Rocker arm Culbuteur		
5	5000070990	2	pc	Ventilstößel Levantaválvula	Valve tappet Pousoir		
6	5100031338	2	pc	Zapfen Pivote	Pin Pivot		
7	5000151028	1	pc	Feder Resorte	Spring Ressort		
8	5100005441	1	pc	Einlassventil Válvula de admisión	Intake valve Soupape d'admission		
9	5100005442	1	pc	Auslassventil Válvula de escape	Outlet valve Soupape d'échappement		
10	5000081760	2	pc	Feder Resorte	Spring Ressort		
11	5100031339	1	pc	Halter Soporte	Holder Attache		
12	5100031339	1	pc	Halter Soporte	Holder Attache		
14	5100005443	1	pc	Führungsblech Chapa de guía	Guide plate Tôle de guidage		
15	5000072778	2	pc	Gewindebolzen Perno prisionero	Stud Boulon	8	
16	5000070984	2	pc	Sechskantmutter Contratuerca	Locknut Contre-écrou	1/4-28in	

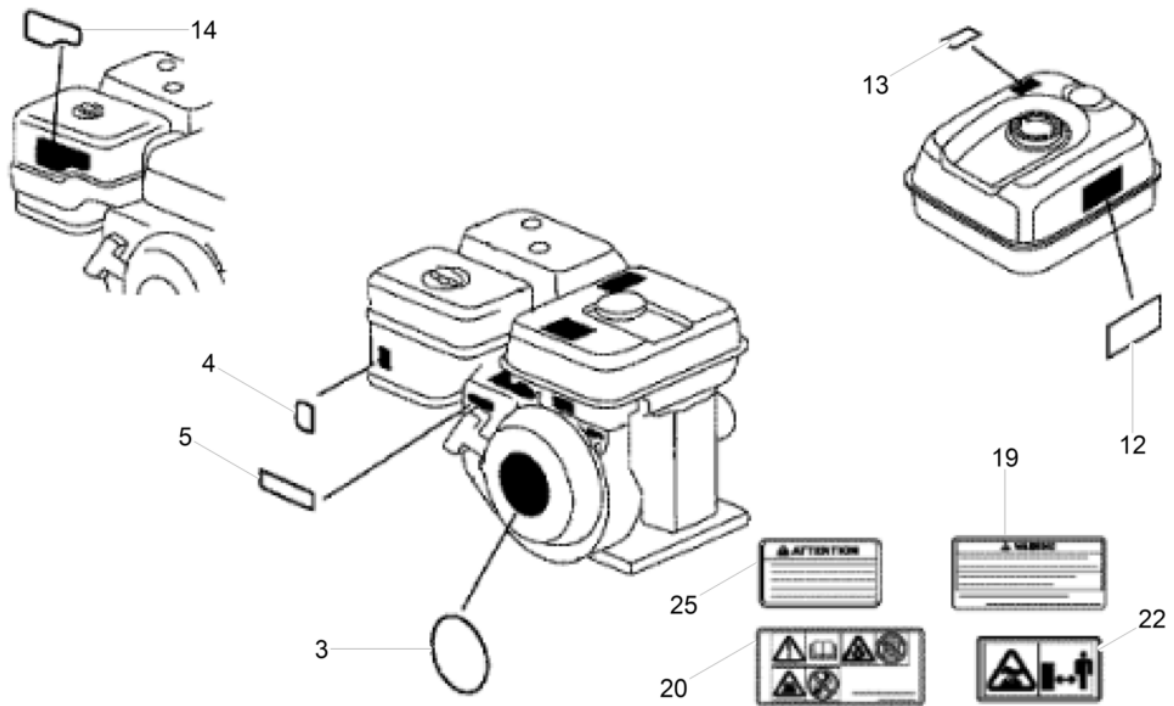

Pos. Item	Artikel Nr. Item no.	Pc.	Unit	Beschreibung Descripción	Description Description	Abm. Dim.	Norm Standard
						Drehmoment Torque	Schmierstoff Lubricant
3	5100005352	1	pc	Aufkleber GX160 Calcomanía gx160	Label gx160 Autocollant gx160		
4	5100005336	1	pc	Aufkleber Calcomanía	Label Autocollant		
5	5000208623	1	pc	Aufkleber Calcomanias	Labels Autocollants		
12	5100000437	1	pc	Warnhinweiß Etiqueta amonestadora	Warning label Étiquette d'avertissement		
13	5100005337	1	pc	Aufkleber Calcomanía	Label Autocollant		
14	5100039033	1	pc	Aufkleber Calcomanía	Label Autocollant		
19	5100000438	1	pc	Warnhinweiß Etiqueta amonestadora	Warning label Étiquette d'avertissement		
20	5100000439	1	pc	Warnhinweiß Etiqueta amonestadora	Warning label Étiquette d'avertissement		
22	5100005340	1	pc	Aufkleber Calcomanía	Label Autocollant		
25	5100005339	1	pc	Aufkleber Calcomanía	Label Autocollant		

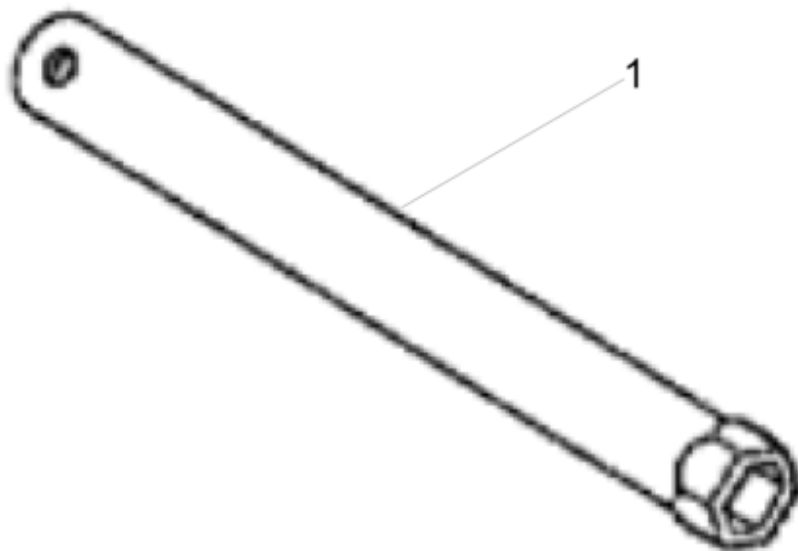

Pos. Item	Artikel Nr. Item no.	Pc.	Unit	Beschreibung Descripción	Description Description	Abm. Dim.	Norm Standard
						Drehmoment Torque	Schmierstoff Lubricant
1	5000217462	1	pc	Schlüssel Llave	Key Clé		

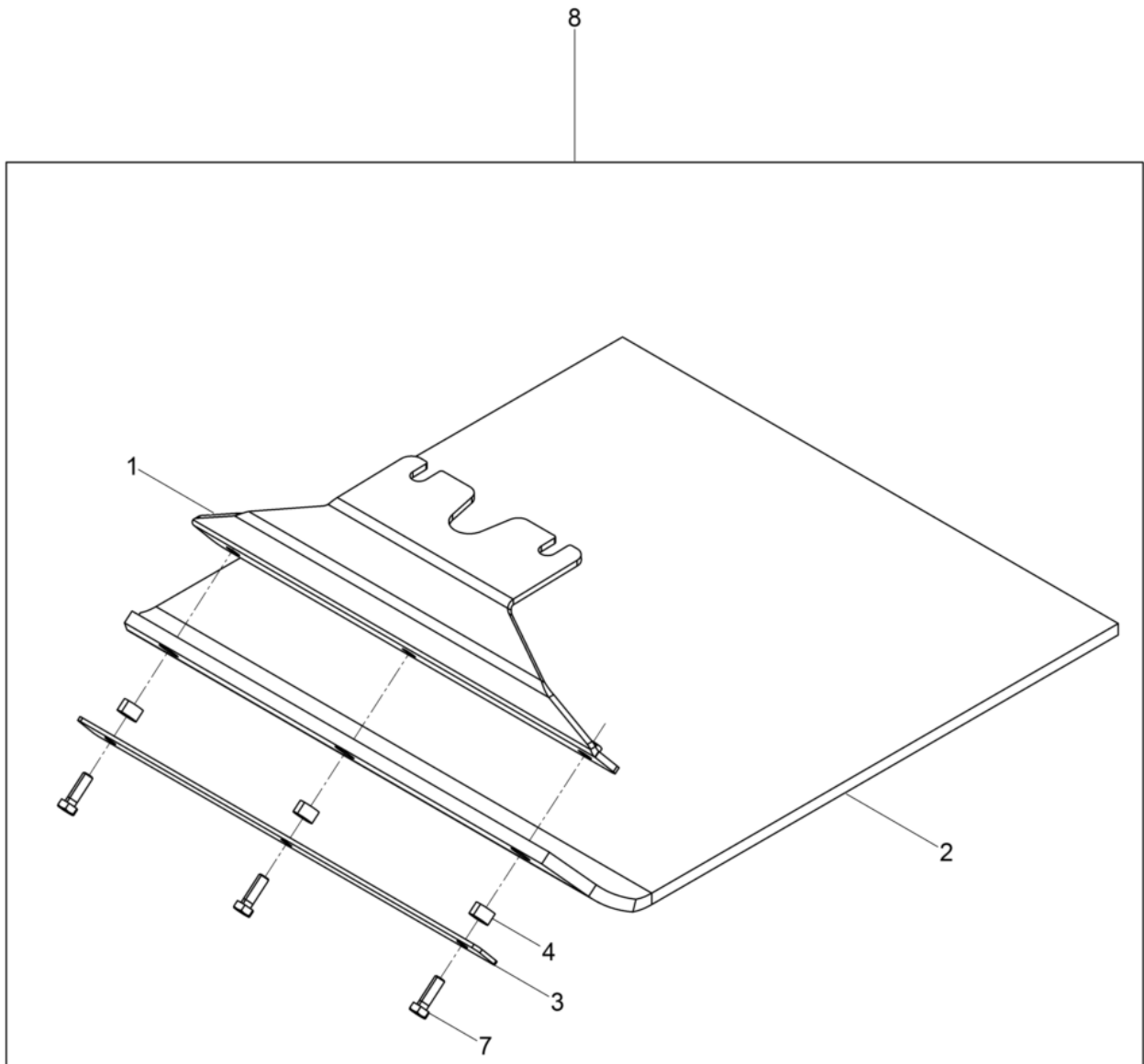

Pos. Item	Artikel Nr. Item no.	Pc.	Unit	Beschreibung Descripción	Description Description	Abm. Dim.	Norm Standard
						Drehmoment Torque	Schmierstoff Lubricant
1	5100016464	1	pc	Winkel Kpl. Ángulo cpl.	Angle cpl. Coude cpl.		
2	5100016466	1	pc	Kunststoffplatte Juego de lamina de uretano	Urethane plate Dispositif de glissement		
3	5100016467	1	pc	Blech Chapa	Plate Tôle		
4	5100017122	3	pc	Buchse Buje	Bush Boîte		
7	5000011457	3	pc	Sechskantschraube Tornillo hexagonal	Hexagonal head cap screw Vis à tête hexagonale	M8 x 25 25Nm/18ft.lbs	
8	5100016463	1	pc	Gleitvorrichtung PGV 1550 Placa de deslizamiento pgv 1550	Urethane pad kit pgv 1550 Jeu de tapis en polyuréthane		

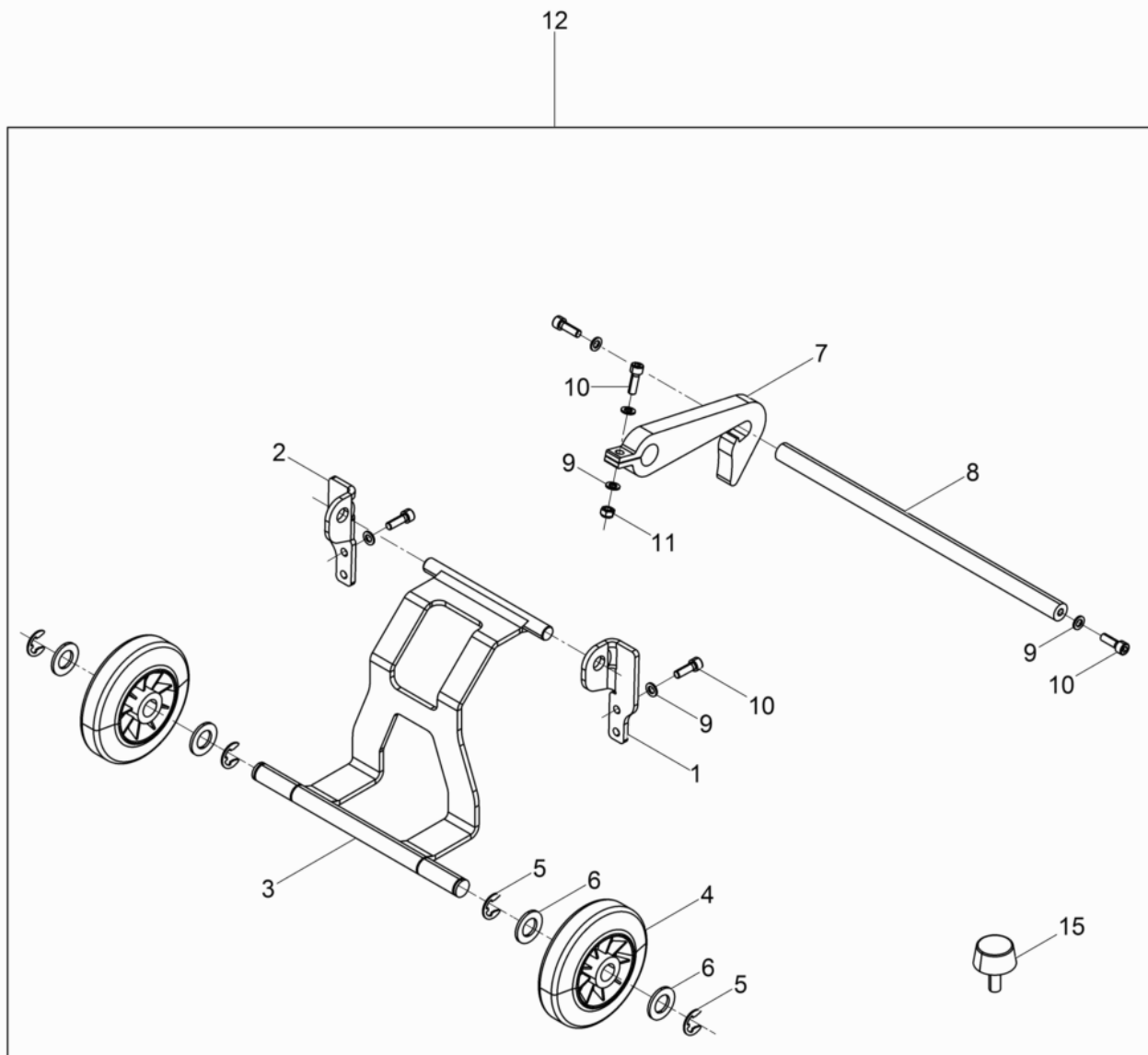

Pos. Item	Artikel Nr. Item no.	Pc.	Unit	Beschreibung Descripción	Description Description	Abm. Dim.	Norm Standard
						Drehmoment Torque	Schmierstoff Lubricant
1	5100016472	1	pc	Halter Soporte	Bracket Support		
2	5100016471	1	pc	Halter Soporte	Bracket Support		
3	5100016469	1	pc	Fahrgestell Dispositivo de transporte	Trolley Chassis		
4	5000021466	2	pc	Rad Rueda	Tire Roue	140 x 37,5	
5	5000103834	4	pc	Sicherungsscheibe Arandela de seguridad	Lock washer Rondelle d'arrêt	15	DIN6799
6	5000010616	4	pc	Scheibe Arandela	Flat washer Rondelle		
7	5100016474	1	pc	Haken Gancho	Hook Crochet		
8	5100018310	1	pc	Strebe Puntual	Brace Contre-fiche		
9	5000010742	8	pc	Scheibe Arandela	Washer Rondelle		
10	5000011542	7	pc	Zylinderschraube Tornillo cilíndrico	Cheese head screw Vis à tête cylindrique	25Nm/18ft.lbs	
11	5000033356	1	pc	Sechskantmutter Tuerca hexagonal	Hexagon nut Écrou hexagonal		
12	5100016468	1	pc	Fahrgestell Kpl. Dispositivo de transporte cpl.	Trolley cpl. Chassis cpl.		
15	5100016317	2	pc	Anschlagpuffer Amortiguador	Shockmount Silentbloc	30 x 15	

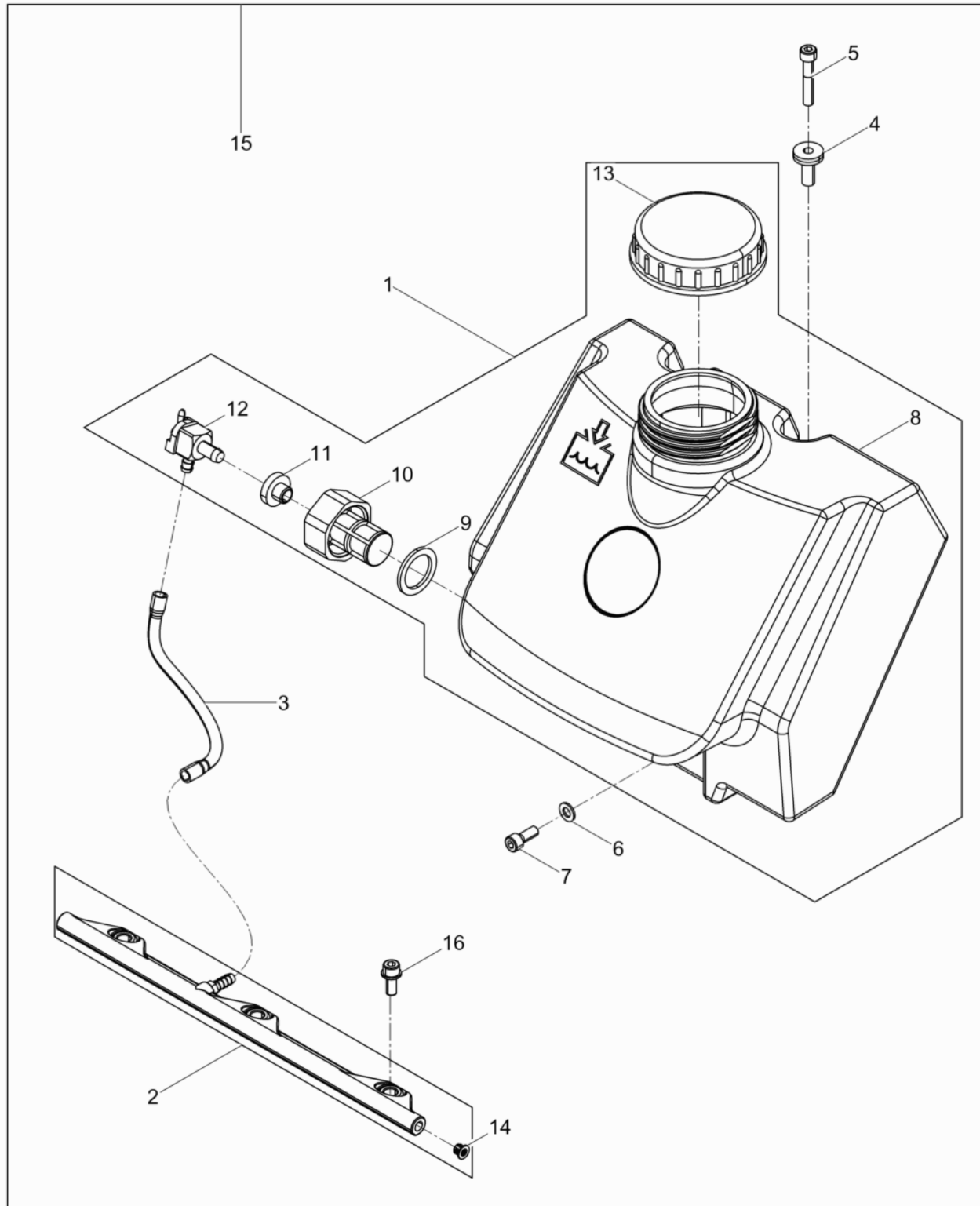

Pos. Item	Artikel Nr. Item no.	Pc.	Unit	Beschreibung Descripción	Description Description	Abm. Dim.	Norm Standard
						Drehmoment Torque	Schmierstoff Lubricant
1	5100028975	1	pc	Wassertank Kpl. Tanque de agua cpl.	Water tank cpl. Reservoir à eau cpl.		
2	5100028977	1	pc	Berieselung Kpl. Systema de riego cpl.	Spinkler system cpl. Installation d'arrosage cpl.		
3	5100028939	1	pc	Wasserschlauch Manguera de agua	Water hose Tuyau d'eau		
4	5100016451	2	pc	Distanzhülse Manguito distanciador	Spacer sleeve Douille d'écartement		
5	5000011538	2	pc	Zylinderschraube Tornillo cilíndrico	Cheese head screw Vis à tête cylindrique	M8 x 45 25Nm/18ft.lbs	ISO4762
6	5000010622	2	pc	Scheibe Arandela	Flat washer Rondelle		
7	5000011543	2	pc	Zylinderschraube Tornillo hueco	Socket head screw Vis à six-pans creux	M8 x 20 24Nm/18ft.lbs	ISO4762
8	5100028976	1	pc	Wassertank Tanque de agua	Watertank Reservoir à eau		
9	5100028934	1	pc	Dichtungsring Anillo sellador	Ring seal Rondelle à étancher		
10	5100028935	1	pc	Wasserfilter Filtro de agua	Water filter Filtre à eau		
11	5000053577	1	pc	Tankbuchse Buje	Tank valve bushing Douille		
12	5100028937	1	pc	Absperrventil Válvula de cierre	Shut-off valve Robinet d'arrêt		
13	5000068351	1	pc	Schraubdeckel Tapa roscable	Screwed cover Couvercle fileté		
14	5100027000	2	pc	Einschraubstopfen Tapón	Plug (threaded) Bouchon		
15	5100028981	1	pc	Berieselung Kpl. Systema de riego cpl.	Sprinkler system cpl Installation d'arrosage cpl.		
16	5100042618	3	pc	Zylinderschraube Tornillo cilíndrico	Cheese head screw Vis à tête cylindrique		



**WACKER
NEUSON**

