



**WACKER
NEUSON**

Ersatzteilkatalog
Spare parts catalog
Catálogo de piezas de repuesto
Catalogue de pièces de rechange

**Walze
Roller
Rodillos
Rouleaux**

RTLX-SC3



Type	RTLX-SC3
Material Number	5200019252
Version	131
Language	de en es fr



www.wackerneuson.com

Copyright © 01.2021
Wacker Neuson America Corporation
Printed in USA.
All rights reserved.

Ein Typenschild mit Typ, Artikelnummer, Version und Maschinen-Nummer ist an jedem Gerät angebracht. Die Daten von diesem Schild bitte notieren, damit sie auch bei Verlust oder Beschädigung des Schildes noch vorhanden sind. Der Typ, die Artikelnummer, die Versions-Nummer und die Maschinen-Nummer sind bei der Ersatzteilbestellung oder Nachfragen bezüglich Service-Informationen stets erforderlich.

Bei den in den Ersatzteillisten fettgedruckten Nummern handelt es sich um empfohlene Ersatzteile. Dies bedeutet, daß diese Teile bei normalen Anwendungsbedingungen natürlicher Abnutzung ausgesetzt sind und gelegentlich ersetzt oder überarbeitet werden müssen. Es wird geraten, diese Teile auf Lager bereit zu haben, um für Service-Arbeiten an diesem Gerät vorbereitet zu sein. Lagerbestände für diese und andere Teile, welche für ausgiebigere Reparaturarbeiten benötigt werden, können je nach Service-Gewohnheiten der einzelnen Kunden variieren.

Die Nummern meines Gerätes sind:

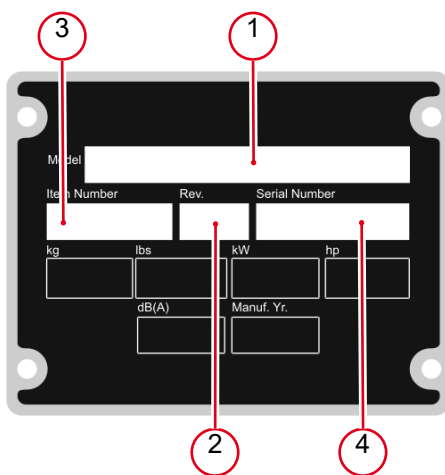

1. Typ
2. Version
3. Artikel-Nr.
4. Maschinen-Nr.

Umrechnungstabelle

Volumeneinheit	
1 ml	0.034 US fl.oz.
1 l	0.260 gal
Längeneinheit	
1 mm	0.039 in
1 m	3.280 ft
Gewicht	
1 kg	2.200 lbs
1 g	0.035 oz
Geschwindigkeit	
1 km/h	0.620 mph
Drehmoment	
1 Nm	0.740 ft.lbs

A nameplate listing the Model Number, Item Number, Revision, and Serial Number is attached to each unit. Please record the information found on this plate so it will be available should the nameplate become lost or damaged. When ordering parts or requesting service information, you will always be asked to specify the model, item number, revision number, and serial number of the unit.

Part Numbers appearing in boldface type are recommended spare parts. This means that these parts are subject to wear under normal operating conditions and may require periodic service or replacement. It is recommended that these items be stocked to meet the expected service requirements of this model. Actual stocking quantities of these and other parts used in more extensive repairs will depend on the service practices of each customer.

My machine's numbers are:



1. Model
2. Revision
3. Item No.
4. Serial No.

Conversion table

Volume unit	
1 ml	0.034 US fl.oz.
1 l	0.260 gal
Unit of length	
1 mm	0.039 in
1 m	3.280 ft
Weight	
1 kg	2.200 lbs
1 g	0.035 oz
Speed	
1 km/h	0.620 mph
Torque	
1 Nm	0.740 ft.lbs

Una placa de identificación con el modelo, número de referencia, nivel de revisión y número de serie ha sido añadida en cada máquina. Favor de anotar los datos en la placa en caso de que la placa de identificación sea destruida o perdida. En todos los pedidos para repuestos necesita siempre el modelo, el número de referencia, el nivel de revisión y el número de serie de la máquina en cuestión.

Los números de partes en negritas en las Listas Ilustradas de Partes son los repuestos recomendados, esto quiere decir que estas partes se desgastarán bajo circunstancias de funcionamiento normales y pueden requerir servicio periódico o su reemplazo. Se recomienda que el cliente mantenga un abastecimiento adecuado de estas partes para poder satisfacer la demanda requerida por el servicio a la máquina. La cantidad de repuestos que el cliente necesitará para reparaciones dependerá de la póliza de servicio de cada cliente.

Los números de mi máquina son:

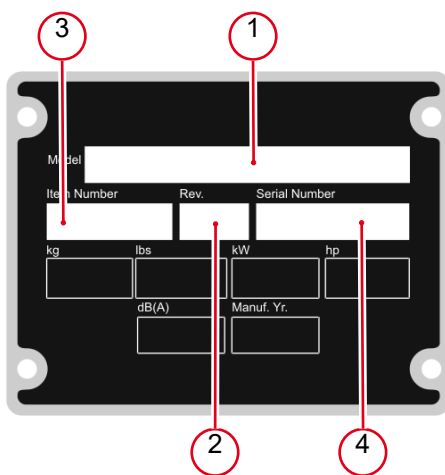

1. Modelo
2. Nivel de revisión
3. Número de referencia
4. Número de Serie

Tabla de conversión

Unidad de volumen	
1 ml	0.034 US fl.oz.
1 l	0.260 gal
Unidad de longitud	
1 mm	0.039 in
1 m	3.280 ft
Peso	
1 kg	2.200 lbs
1 g	0.035 oz
Velocidad	
1 km/h	0.620 mph
Par de apriete	
1 Nm	0.740 ft.lbs

Une plaque signalétique mentionnant le modèle, le numéro de référence, le niveau de revision et le numéro de série est fixée sur chaque machine. Veuillez noter les informations relevées sur cette plaque de façon à ce qu'elles soient toujours disponibles si la plaque signalétique venait à être perdue ou endommagée. Lorsque vous commandez des pièces détachées ou vous sollicitez des informations après-vente, on vous demandera toujours de préciser le modèle, le numéro de référence, le niveau de revision et le numéro de série de la machine.

Les numéros de pièces imprimés en caractères gras dans les Listes des Pièces Détachées de ce manuel sont les pièces détachées recommandées par la Wacker. Cela veut dire que ces pièces sont sujettes à usure dans des conditions de travail normales et peuvent nécessiter de l'entretien ou leur remplacement. Nous recommandons que vous disposiez d'un stock de ces pièces pour pouvoir satisfaire la demande d'entretien de cette machine. Le client doit décider lui-même de la quantité exacte de pièces de rechange qu'il disposera dans ses stocks.

Les numéros de ma machine son :

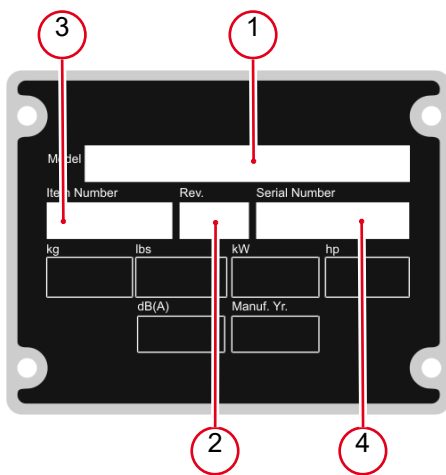

1. Typ
2. Version
3. Artikel-Nr.
4. Maschinen-Nr.

Table de conversion

Unité de volume	
1 ml	0.034 US fl.oz.
1 l	0.260 gal
Unité de longueur	
1 mm	0.039 in
1 m	3.280 ft
Poids	
1 kg	2.200 lbs
1 g	0.035 oz
Vitesse	
1 km/h	0.620 mph
Couple de serrage	
1 Nm	0.740 ft.lbs

Motorkasten Engine compartment Caja de motor Boîte de moteur	12
Vorderrahmen Front frame Bastidor delantero Châssis avant	18
Hinterrahmen Rear frame Bastidor de atrás Châssis arrière	22
Knickgelenk Articulated steering joint Unión articulada de dirección Joint articulé	26
Armaturen/Leitungen Electric equipment/wiring Equipo eléctrico/cables Équipement électrique/câblage	28
Hydraulik-Rohrleitung Hydraulic piping Tubería hidráulica Canalisation hydraulique	32
Hydraulik-Rohrleitung-2 Hydraulic piping-2 Tubería hidráulica-2 Canalisation hydraulique-2	34
Vorderdeckel Front cover Tapa delantera Couvercle avant	38
Steuerkontrolle Rear section/controls Sección posterior/palanca de mando Partie arrière/guidons	40
Hinterdeckel Rear cover Tapa de atrás Couvercle arrière	44
Bandagenantrieb Drum drive Accionamiento de tambor Entraînement de tambour	46
Bandagenantrieb Mit Bremse Drum drive w/brake Accionamiento de tambor con freno Entraînement de tambour avec f	50

Vorderbandage Front drum Tambor delantero Tambour avant	56
--	----

Hinterbandage Rear drum Tambor de atrás Tambour arrière	58
--	----

Erreger Kpl. Exciter cpl. Excitador compl. Excitatrice compl.	60
---	----

Hydraulikverteiler Hydraulic manifold Distribuidor hidráulico Tubulure hydraulique	62
---	----

Hydrauliktank Hydraulic tank Tanque hidráulico Réservoir hydraulique	66
---	----

Sender Transmitter module Transmisor Transmetteur	68
--	----

Aufkleber Labels Calcomanias Autocollants	70
--	----

Kohler-Motor Engine-kohler Motor kohler Moteur kohler	
--	--

Kurbelwelle Crankshaft Cigueñal Vilebrequin	72
--	----

Kolben/Pleuel Piston/connecting rod Pistón/biela Piston/bielle	74
---	----

Schwungrad Flywheel Volante Volant	76
---	----

Scheibensatz Pulley cpl. Conjunto cabrestante Ensemble poulie	78
--	----

Kurbelgehäuse Crankcase Cárter Carter	80
Zylinderkopf Cylinder head Culata Culasse	82
Zylinderkopfhaube Cylinder head cover Tapa del cilindro Couvercle supérieur	84
Seite Des Schwungrads Flywheel side support Soporte del lado del volante m Volant moteur côté soutien	86
Kraftstoffeinspritzsystem Fuel injection system Sistema de inyección de combustible Système d'injection de carbura	88
Nockenwelle Camshaft Arbol de levas Arbre à cames	90
Kipphebel/Ventile Rocker arms/valves Balancines/válvulas Culbuteurs/soupapes	92
Motorsteuerung Timing gear Regulador Régulateur	94
Ölpumpe Oil pump Bomba de aceite Pompe à huile	96
Ölwanne Oil pan Colector de aceite Cuvette-carter à huile	98
Ölfilter Oil filter Filtro de aceite Filtre d'huile	100
Ölpeilstab Oil dipstick Indicador del nivel de aceite Réglette-jauge d'huile	102

Scheibensatz Breather system Conjunto cabrestante Système de reniflard	104
---	-----

Drehzahlregler Speed governor Regulador de velocidad Régulateur de vitesse	106
---	-----

Steuerungen Controls Mandos Commandes	108
--	-----

Kraftstoffsolenoid Fuel solenoid Solenóide de combustible Solénoïde à carburant	110
--	-----

Kraftstofffilter Fuel filter Filtro de combustible Filtre à carburant	112
--	-----

Förderpumpe Fuel feed pump Bomba de alimentación Pompe d'alimentation	114
--	-----

Kraftstoffleitungen Fuel pipes Tubos de combustible Conduites de carburant	116
---	-----

Gebälserad Fan Ventilador Ventilateur	118
--	-----

Temperatursensoreinheit Temperature sensor Unidad de alerta de temperatura Appareil d'alerte de températu	120
--	-----

Wasser-Verteiler Water manifold Distribuidor del agua Rampe d'arrosage	122
---	-----

Wasserpumpe Water pump Bomba del agua Pompe à eau	124
--	-----

Einlassluftleitblech Air inlet manifold Conducto de aire de entrada Canal d'air d'admission	126
--	-----

Auspuffkrümmer
Exhaust manifold
Distribuidor de escape
Collecteur d'échappement128

Spannungsregler
Voltage regulator
Regulador de voltaje
Régulateur de tension130

Anlasser
Starter motor
Motor de arranque
Démarreur132

Glühkerze
Glow plug
Tapón luminoso
Bougie de préchauffage134

Adapter Für Hydraulikpumpe
Hydraulic pump adapter
Adaptador para bomba hidráulica
Raccord pour pompe hydraulique136

Adapter Für Hydraulikpumpe 2
Hydraulic pump adapter 2
Adaptador para bomba hidráulica 2
Raccord pour pompe hydraulique138

Plattenrückwand
Backplate
Placa de atrás
Plaque de fond140

Riemenschutz
Beltguard
Guardacorrea
Protection de courroie142

Sonderzubehör
Accessories
Accesorios
Accessoires

Bandagensatz (glatt)
Smooth drum kit
Juego de tambor (plano)
Jeu de tambour (lisse)144

Wartungssätze / Satz
Maintenance / kits
Entretien / juego
Mantenimiento / jeu

O-Ringsatz
O-ring kit
Juego de anillo-o
Jue de joint torique146



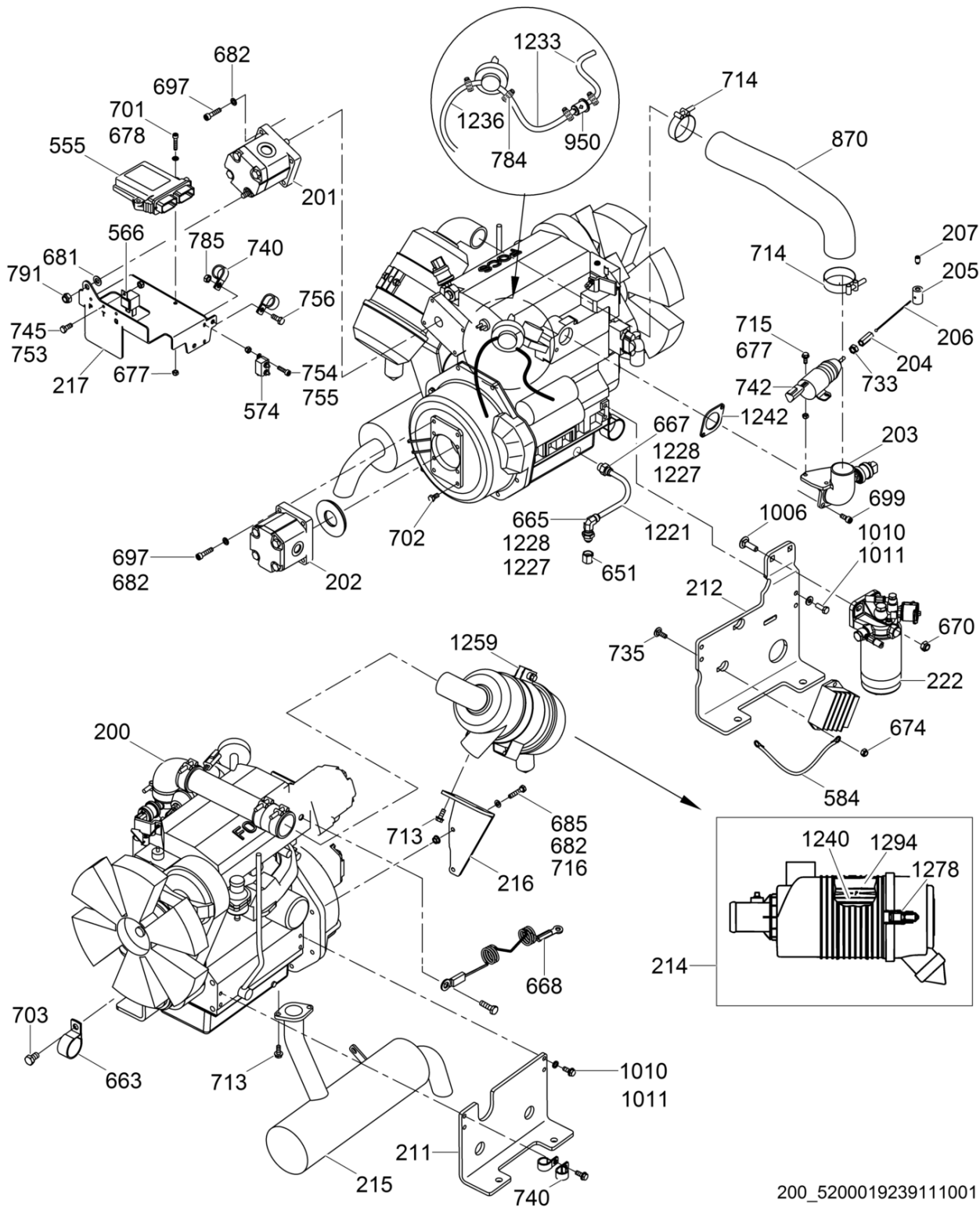

200_5200019239111001

Pos. Item	Artikel Nr. Item no.	Pc.	Unit	Beschreibung Descripción	Description Description	Abm. Dim.	Norm Standard
						Drehmoment Torque	Schmierstoff Lubricant
200	5200022255	1	pc	Kohler-Motor Motor kohler	Engine-kohler Moteur kohler		
201	5200022250	1	pc	Zahnradpumpe Bomba de accionamiento	Drive pump Pompe d'entraînement		
202	5200022239	1	pc	Zahnradpumpe Bomba del excitador	Exciter pump Pompe de l'excitatrice		
203	5000119619	1	pc	Adapter Adaptador	Adapter Raccord		
204	5000155487	1	pc	Adapter Adaptador	Adaptor Adaptateur		
205	5000119695	1	pc	Hülse Collar	Collar Douille		
206	5000150022	1	pc	Kabel Cable	Cable Câble		
207	5000156315	1	pc	Gewindestift Tornillo	Setscrew Vis	M6 x 10	
211	5000115877	1	pc	Konsole Soporte	Bracket Support		
212	5000162855	1	pc	Konsole (Links) Soporte (izquierdo)	Lh bracket Support (gauche)		
214	5000176114	1	pc	Luftfilter Filtro del aire	Air cleaner Boîtier de filtre complet		
215	5000119582	1	pc	Auspufftopf Silenciador	Muffler Pot d'échappement		
216	5000154686	1	pc	Luftfilterkonsole Soporte de filtro del aire	Air cleaner bracket Support du filtre à air		
217	5000150293	1	pc	Konsole Soporte	Bracket Support		
222	5000181844	1	pc	Kraftstofffilter Mit Wasserabschei- Der Filtro de combustible con dispositivo para separar	Fuel filter w/water separator Filtre de carburant avec purge		
555	5200025080	1	pc	Motorkontrollmodul Módulo de mando del motor	Engine control module Module de contrôle de moteur		
566	5000085437	3	pc	Relais Relai	Relay Relais		
574	5000150961	1	pc	Unterbrecher Interruptor de circuito	Circuit breaker Coupe-circuit	50A 12V	
574	5000156190	1	pc	Deckel Tapa	Cover Couvercle		
584	5000110557	1	pc	Erdungsdraht Alambre a tierra	Ground wire Fil de masse	12in	
651	5000119929	1	pc	Verschraubung, Kappe Unión, tapa	Fitting cap Raccord, capuchon	No.8	
655	5000119906	1	pc	Schlauchschelle Abrazaderas de manguera	Hose clamp Agrafe de tuyau	No.20 x 0,81 x 1,75in	
663	5000119937	1	pc	Schlauchschelle Abrazaderas de manguera	Hose clamp Agrafe de tuyau	44	
665	5000119960	2	pc	Verschraubung Unión	Fitting Raccord	No.8	
667	5000119962	2	pc	Verschraubung Unión	Fitting Raccord	No.8	
668	5000154402	1	pc	Kabel Cable	Cable Câble		
670	5000096087	2	pc	Sechskantmutter Tuerca hexagonal	Hexagon nut Écrou hexagonal	M10	DIN 1661
674	5000010367	2	pc	Sechskantmutter Tuerca hexagonal	Hexagon nut Écrou hexagonal	M8	DIN985

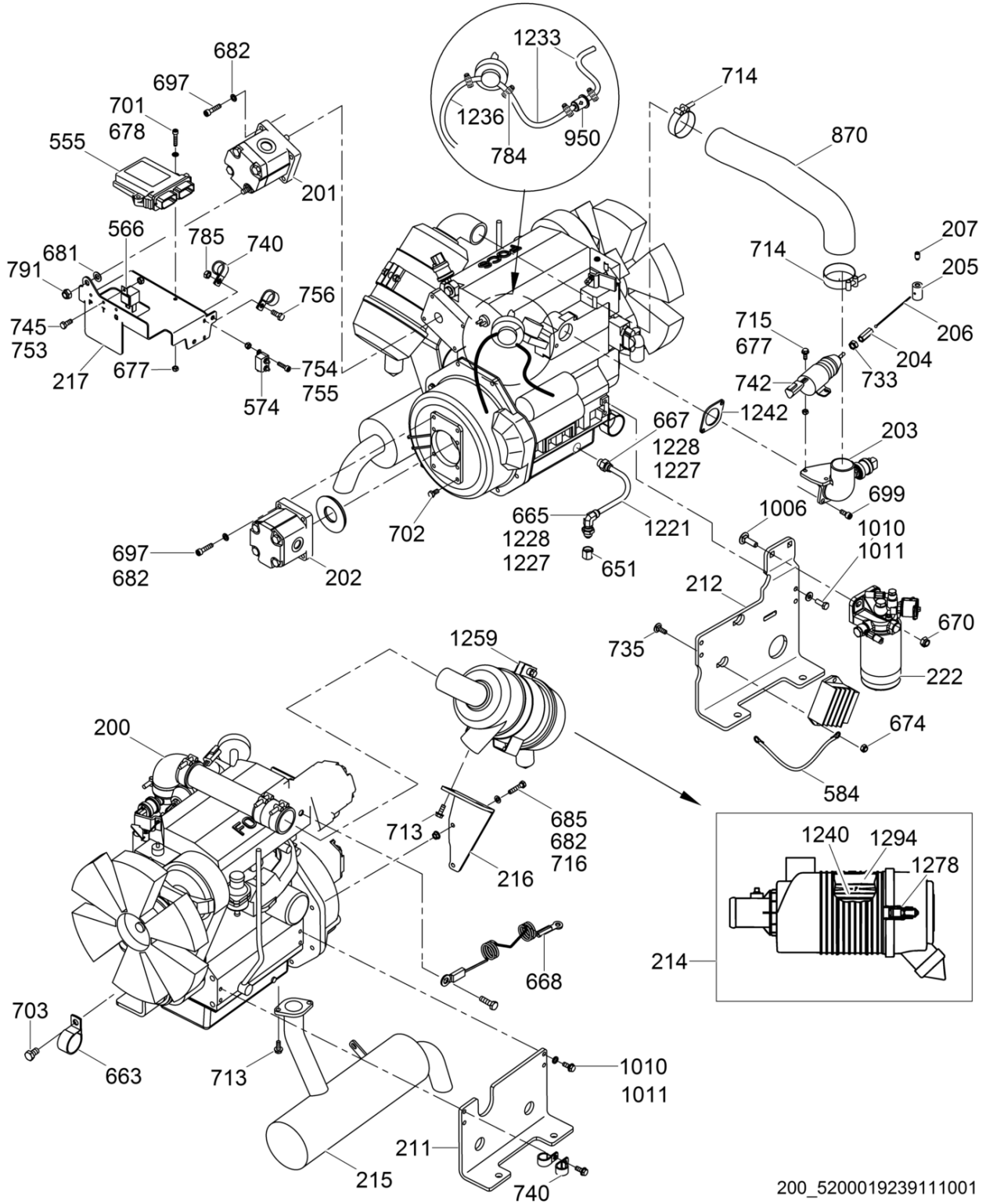

200_5200019239111001

Pos. Item	Artikel Nr. Item no.	Pc.	Unit	Beschreibung Descripción	Description Description	Abm. Dim.	Norm Standard
						Drehmoment Torque	Schmierstoff Lubricant
677	5000010368	4	pc	Sechskantmutter Tuerca hexagonal	Hexagon nut Écrou hexagonal	M6	DIN985
678	5000010624	2	pc	Scheibe Arandela	Flat washer Rondelle		
681	5000010621	1	pc	Scheibe Arandela	Flat washer Rondelle		
682	5000010622	10	pc	Scheibe Arandela	Flat washer Rondelle		
685	5000011341	2	pc	Sechskantschraube Tornillo hexagonal	Hexagonal head cap screw Vis à tête hexagonale	M8 x 40 25Nm/18ft.lbs	DIN931
690	5000011438	2	pc	Sechskantschraube Tornillo hexagonal	Hexagonal head cap screw Vis à tête hexagonale	M10 x 35 49Nm/36ft.lbs	DIN933
697	5000011540	8	pc	Zylinderschraube Tornillo cilíndrico	Cheese head screw Vis à tête cylindrique	M8 x 35 41Nm/30ft.lbs	ISO4762
699	5000011543	2	pc	Zylinderschraube Tornillo hueco	Socket head screw Vis à six-pans creux	M8 x 20 41Nm/30ft.lbs	ISO4762
701	5000011549	2	pc	Zylinderschraube Tornillo cilíndrico	Cheese head screw Vis à tête cylindrique	M6 x 30 17Nm/13ft.lbs	ISO4762
702	5000012361	2	pc	Sechskantschraube Tornillo hexagonal	Hexagonal head cap screw Vis à tête hexagonale	M8 x 16 25Nm/18ft.lbs	DIN933
703	5000012368	1	pc	Sechskantschraube Tornillo hexagonal	Hexagonal head cap screw Vis à tête hexagonale	M12 x 20 86Nm/63ft.lbs	DIN933
713	5000028404	4	pc	Sechskantflanschschraube Tornillo hexagonal de brida	Hexagonal flange head screw Vis hexagonale de bride	M8 x 20 34Nm/25ft.lbs	
714	5000028698	2	pc	Schelle Mit T-Bolzen Abrazadera con perno forma t	T-bolt clamp Agrafe avec boulon t	2-3/8in	
715	5000028949	2	pc	Sechskantflanschschraube Tornillo hexagonal de brida	Hexagonal flange head screw Vis hexagonale de bride	M6 x 16 10Nm/7ft.lbs	
716	5000030066	2	pc	Sechskantmutter Contratuerca	Locknut Contre-écrou	M8	
733	5000010880	1	pc	Sechskantmutter Tuerca hexagonal	Hexagon nut Écrou hexagonal		
735	5000111845	2	pc	Schloßschraube Tornillo de carruaje	Carriage bolt Boulon brut à tête bombée	M8 x 25	
740	5000110458	4	pc	Schelle Abrazadera	Clamp Agrafe		
742	5000155486	1	pc	Gasreglerstellteil Actuador de acelerador	Throttle actuator Dispositif de commande des gaz		
745	5000011477	3	pc	Sechskantschraube Tornillo hexagonal	Hexagonal head cap screw Vis à tête hexagonale	M5 x 12 6Nm/4ft.lbs	DIN933
753	5000010369	3	pc	Sechskantmutter Tuerca hexagonal	Hexagon nut Écrou hexagonal		
754	5000011570	2	pc	Zylinderschraube Tornillo cilíndrico	Cheese head screw Vis à tête cylindrique	5Nm/4ft.lbs	
755	5000010370	1	pc	Sechskantmutter Tuerca hexagonal	Hexagon nut Écrou hexagonal		
756	5000012362	2	pc	Sechskantschraube Tornillo hexagonal	Hexagonal head cap screw Vis à tête hexagonale	25Nm/18ft.lbs	
784	5000028707	6	pc	Schelle Abrazadera	Clamp Agrafe	0,21-0,63	
785	5000010882	1	pc	Sechskantmutter Tuerca hexagonal	Hexagon nut Écrou hexagonal		
791	5000010365	1	pc	Sicherungsmutter Contratuerca	Lock nut Contre-écrou	M10 25Nm/18ft.lbs	DIN 980 V
870	5000164861	1	pc	Einlasskrümmerschlauch Manguera del distribuidor de admisión	Intake manifold hose Tuyau de collecteur d'admissio		

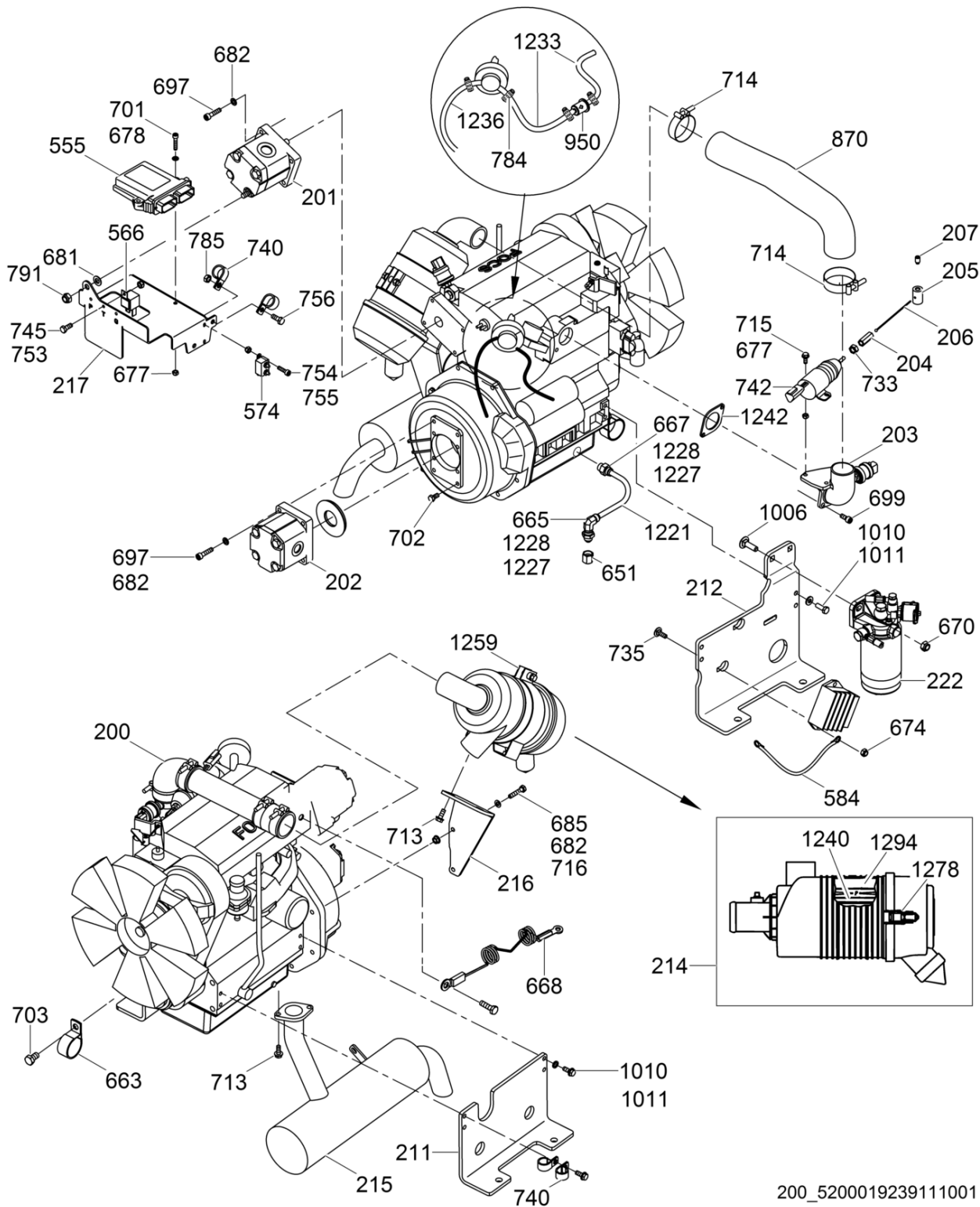

200_5200019239111001

Pos. Item	Artikel Nr. Item no.	Pc.	Unit	Beschreibung Descripción	Description Description	Abm. Dim.	Norm Standard
						Drehmoment Torque	Schmierstoff Lubricant
950	5000112497	1	pc	Kraftstofffilter Filtro de combustible	Fuel filter Filtre à carburant		
1006	5000162829	2	pc	Schloßschraube Tornillo de carruaje	Carriage bolt Boulon brut à tête bombée	M10 x 35	DIN603
1010	5000165460	8	pc	Sechskantschraube Tornillo hexagonal	Hexagonal head cap screw Boulon à tête hexagonale	M8 x 22, 10.9 31Nm/23ft.lbs	
1011	5000033198	8	pc	Spannscheibe Arandela elástica	Lockwasher Rondelle de ressort	8	DIN6796
1221	5000119683	1	pc	Hydraulikschlauch Manguera hidráulica	Hydraulic hose Tuyau hydraulique	380	
1227	5000080737	2	pc	O-Ring Anillo-o	O-ring Joint torique	0,49 x 0,07in #8 ORFS	
1228	5000080732	2	pc	O-Ring Anillo-o	O-ring Joint torique	0,64 x 0,09in #8	
1233	5000183205	1	pc	Kraftstoffleitung Manguera de combustible	Fuel hose Tuyau de carburant	3/16 ID x 46,60in	
1236	5000159556	1	pc	Kraftstoffleitung Manguera de combustible	Fuel hose Tuyau de carburant	1/4 x 75,6in	
1240	5000160171	1	pc	Filtereinsatz Cartucho filtrante	Airfilter element Element filtrant		
1242	5000159294	1	pc	Dichtung Junta de estanqueidad	Gasket Garniture		
1259	5000164069	2	pc	Luftfilterkonsole Soporte de filtro del aire	Air filter bracket Support du filtre à air		
1278	5000171456	2	pc	Klemme Abrazaderaro de aire	Clamp Pince		
1294	5000162184	1	pc	Sekundärelement Elemento secundario	Secondary element Cartouche secondaire		

Vorderrahmen
Front frame
Basitidor delantero
Châssis avant

RTLX-SC3



Pos. Item	Artikel Nr. Item no.	Pc.	Unit	Beschreibung Descripción	Description Description	Abm. Dim.	Norm Standard
						Drehmoment Torque	Schmierstoff Lubricant
100	5000116471	1	pc	Vorderrahmen Chasis delantero	Front frame Châssis avant		
101	5000154348	1	pc	Kühler Radiador	Radiator Radiateur		
102	5000177118	1	pc	Kühlerschutzbügel Guardarradiador	Radiator guard Pare-chocs de radiateur		
104	5000150205	1	pc	Puffer Amortiguador	Shockmount Silentbloc	25 x 19-60 Sh	
105	5000150206	2	pc	Puffer Amortiguador	Shockmount Silentbloc	38,1 x 25,4-60 Sh	
106	5000155119	1	pc	Oberkühlwasserschlauch Manguera superior del radiador	Radiator top hose Tuyau supérieur du radiateur		
107	5000155120	1	pc	Unterkühlwasserschlauch Manguera inferior del radiador	Radiator bottom hose Tuyau inférieur du radiateur		
108	5000155121	1	pc	Schutz (Rechts) Protector (derecha)	Rh fan guard Protection (droite)		
109	5000155128	1	pc	Schutz (Links) Protector (izquierdo)	Lh fan guard Protection (gauche)		
110	5000157209	1	pc	Überlaufflasche Botella de rebose	Bottle-overflow Bouteille de trop-plein		
111	5000157255	1	pc	Kappe Tapa	Cap Couvercle		
112	5000156236	1	pc	Obere Abdeckung Tapa superior	Top fan cover Couvercle supérieur		
113	5000156238	1	pc	Deckel (Rechts) Tapa (derecha)	Rh fan cover Couvercle (droite)		
114	5000156240	1	pc	Deckel (Links) Tapa (izquierdo)	Lh fan cover Couvercle (gauche)		
208	5000156131	1	pc	Schlauch Manguera	Hose Tuyau		
218	5000150225	1	pc	Dichtung Empaque	Seal Joint		
221	5000150228	1	pc	Dichtung Empaque	Seal Joint		
403	5000119984	1	pc	Stift Pasador	Pin Goupille		
404	5000181474	2	pc	Scharnier Bisagra	Hinge Charnière		
405	5000164540	2	pc	Abstandshülse Espaciador	Bushing spacer Entretoise		
411	5000150098	1	pc	Verriegelung Aldaba	Latch Loquet		
417	5000150104	1	pc	Zylinder Cilindro	Cylinder Cylindre		
458	5200024880	1	pc	Ölkühler Refrigerador de aceite	Hydraulic oil cooler Réfrigérant à l'huile		
459	5000045719	4	pc	Scheibe Arandela	Flat washer Rondelle	8,4	DIN7349
460	5100052302	1	pc	Ölkühler-Dichtung Sello del enfriador de aceite	Oil cooler seal Joint de refroidisseur d'huile		
652	5000157166	7	pc	Schloßschraube Tornillo de carruaje	Carriage bolt Boulon brut à tête bombée	M8 x 45	
655	5000119906	4	pc	Schlauchschele Abrazaderas de manguera	Hose clamp Agrafe de tuyau	No.20 x 0,81 x 1,75in	
664	5000119938	2	pc	Schlauchschele Abrazaderas de manguera	Hose clamp Agrafe de tuyau	No.32	

Vorderrahmen
Front frame
Basitidor delantero
Châssis avant

RTLX-SC3



Pos. Item	Artikel Nr. Item no.	Pc.	Unit	Beschreibung Descripción	Description Description	Abm. Dim.	Norm Standard
						Drehmoment Torque	Schmierstoff Lubricant
670	5000010365	2	pc	Sicherungsmutter Contratuerca	Lock nut Contre-écrou	M10 25Nm/18ft.lbs	DIN 980 V
673	5000010366	4	pc	Sechskantmutter Tuerca hexagonal	Hexagon nut Écrou hexagonal	M12X1.75	DIN985
674	5000011310	6	pc	Sechskantschraube Tornillo hexagonal	Hexagonal head cap screw Vis à tête hexagonale	M8 x 85 25Nm/18ft.lbs	DIN931
682	5000010622	12	pc	Scheibe Arandela	Flat washer Rondelle		
684	5000011151	4	pc	Schloßschraube Tornillo de carruaje	Carriage bolt Boulon brut à tête bombée	M8 x 30	DIN603
708	5000016434	4	pc	Sechskantschraube Tornillo hexagonal	Hexagonal head cap screw Vis à tête hexagonale	M12 x 40 120Nm/89ft.lbs	
715	5000028949	2	pc	Sechskantflanschschraube Tornillo hexagonal de brida	Hexagonal flange head screw Vis hexagonale de bride	M6 x 16 10Nm/7ft.lbs	
716	5000030066	13	pc	Sechskantmutter Contratuerca	Locknut Contre-écrou	M8	
722	5000073164	14	pc	Sechskantflanschschraube Tornillo hexagonal de brida	Hexagonal flange head screw Vis hexagonale de bride	M6 x 10 10Nm/7ft.lbs	
726	5000085957	6	pc	Schraube Tornillo	Screw Vis	M8 x 30 25Nm/18ft.lbs	
727	5000155125	2	pc	Gewindebolzen Perno prisionero	Stud Goujon	M8 x 10	
732	5000110969	6	pc	Klemmutter Sujetador	Clip nut Agrafe	M8	
739	5000155841	8	pc	Schloßschraube Tornillo de carruaje	Carriage bolt Boulon brut à tête bombée	M8 x 20	
747	5000012364	2	pc	Sechskantschraube Tornillo hexagonal	Hexagonal head cap screw Vis à tête hexagonale	M10 x 20 49Nm/36ft.lbs	DIN 933
777	5000029117	2	pc	Sicherungsmutter Contratuerca	Lock nut Contre-écrou	M6	
785	5000010882	2	pc	Sechskantmutter Tuerca hexagonal	Hexagon nut Écrou hexagonal		
789	5000114393	2	pc	Schmiernippel Grasera	Grease fitting Graisseur	M6 x 1	
792	5000010373	2	pc	Scheibe Arandela	Flat washer Rondelle	6	ISO7093
867	5000160294	1	pc	Abstandsstück Espaciador	Spacer Entretoise		
871	5000181897	1	pc	Saugverteiler Distribuidor de succión	Suction manifold Collecteur d'aspiration		
1035	5000163899	1	pc	Konsole Soporte	Bracket Support		
1040	5000163898	1	pc	Kühlerträger Soporte del radiador	Radiator bracket Support de radiateur		
1041	5000163464	2	pc	Tülle Ojal	Grommet Passe-fil	1 x 1-3/4 x 1/4in	
1230	5000159559	1	pc	Profilgummi Moldura	Seal-trim Garniture	1.0in	
1231	5000159560	1	pc	Profilgummi Moldura	Seal-trim Garniture	17in	
1232	5000159561	1	pc	Profilgummi Moldura	Seal-trim Garniture	1000	
1260	5000164350	1	pc	Kühlerverschlußdeckel Tapa del radiador	Radiator cap Couvercle du radiateur		

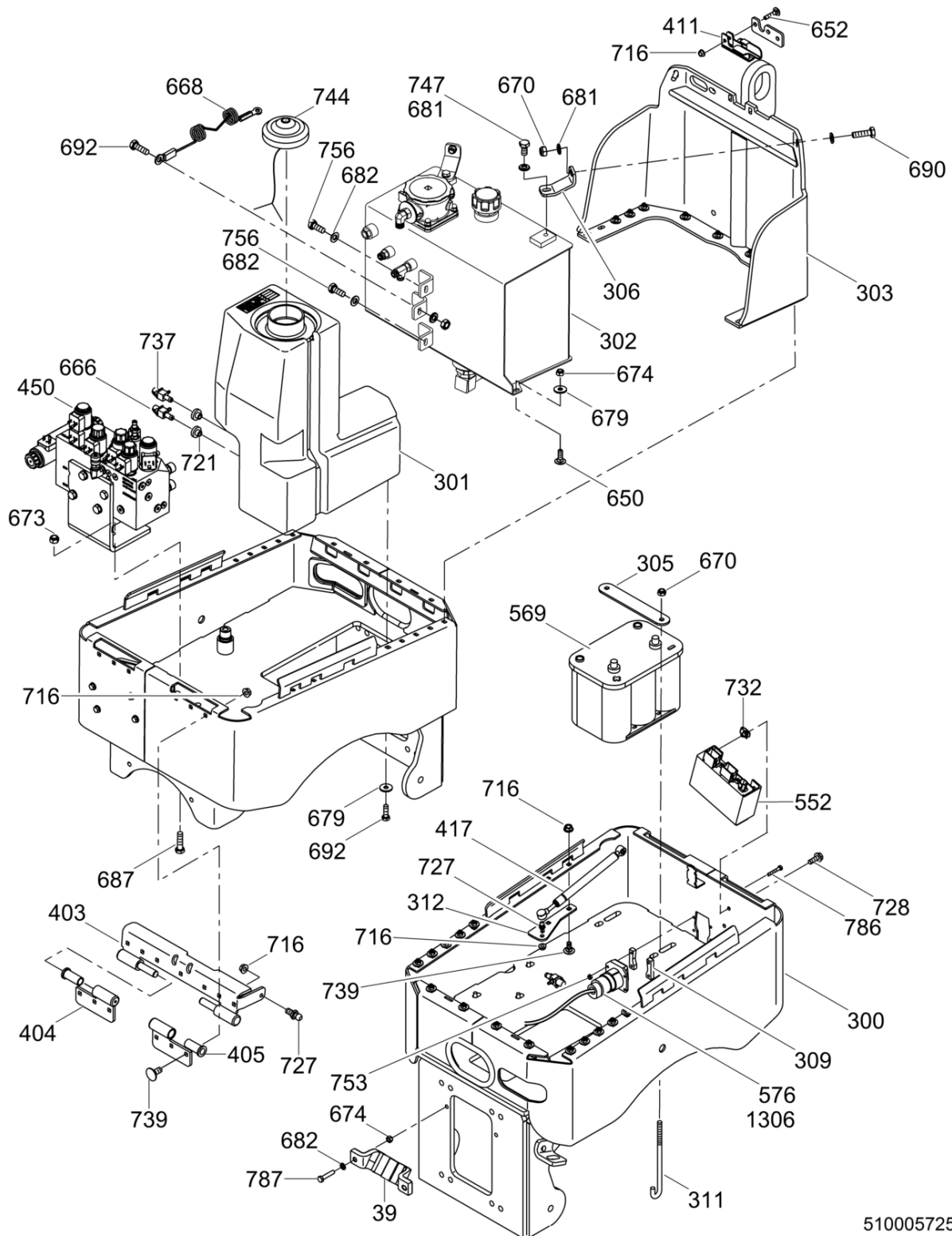

5100057253_01

Pos. Item	Artikel Nr. Item no.	Pc.	Unit	Beschreibung Descripción	Description Description	Abm. Dim.	Norm Standard
						Drehmoment Torque	Schmierstoff Lubricant
39	5100035870	1	pc	Schlauchführungshalter Support de guidage de tuyau	Hose guide bracket Soporte de la manguera		
300	5000117176	1	pc	Hinterrahmen Chasis de atrás	Rear frame Châssis arrière		
301	5000153625	1	pc	Kraftstofftank Depósito de combustible	Fuel tank Réservoir de carburant		
302	5200000844	1	pc	Hydrauliktank Tanque hidráulico	Hydraulic tank Réservoir hydraulique		
303	5000150089	1	pc	Haube Guardera	Shroud Carénage		
305	5000152305	1	pc	Platte Placa	Plate Plaque		
306	5000154260	1	pc	Konsole Soporte	Bracket Support		
309	5000154751	1	pc	Abstandsstück Espaciador	Spacer Entretoise		
311	5000156164	2	pc	Stange Varilla	Rod Tringle		
312	5000154712	1	pc	Konsole Soporte	Bracket Support		
403	5000119984	1	pc	Stift Pasador	Pin Goupille		
404	5000181474	2	pc	Scharnier Bisagra	Hinge Charnière		
405	5000164540	2	pc	Abstandshülse Espaciador	Bushing spacer Entretoise		
411	5000150098	1	pc	Verriegelung Aldaba	Latch Loquet		
417	5000150104	1	pc	Zylinder Cilindro	Cylinder Cylindre		
450	5100049600	1	pc	Hydraulikverteiler Distribuidor hidráulico	Hydraulic manifold Tubulure hydraulique		
552	5000165515	1	pc	Decodiermodul Módulo decodificador	Decoder module Module de décodage		
569	5000165552	1	pc	Batterie Batería	Battery Batterie	12V	
576	5000170950	1	pc	Stecker Und Kabelbaum Kpl. Enchufe y conjunto de cables compl.	Plug and harness cpl. Fiche et harnais de câbles éle		
650	5000157165	14	pc	Schloßschraube Tornillo de carruaje	Carriage bolt Boulon brut à tête bombée	M8 X 25 8,8	
652	5000157166	3	pc	Schloßschraube Tornillo de carruaje	Carriage bolt Boulon brut à tête bombée	M8 x 45	
666	5000119927	1	pc	Verschraubung Unión	Fitting Raccord	1/4in	
668	5000154402	1	pc	Kabel Cable	Cable Câble		
670	5000010365	4	pc	Sicherungsmutter Contratuerca	Lock nut Contre-écrou	M10 25Nm/18ft.lbs	DIN 980 V
673	5000010366	4	pc	Sechskantmutter Tuerca hexagonal	Hexagon nut Écrou hexagonal	M12X1.75	DIN985
674	5000010367	2	pc	Sechskantmutter Tuerca hexagonal	Hexagon nut Écrou hexagonal	M8	DIN985
679	5000160298	6	pc	Scheibe Arandela elástica	Flat washer Rondelle de ressort	B8.4	
681	5000010621	6	pc	Scheibe Arandela	Flat washer Rondelle		

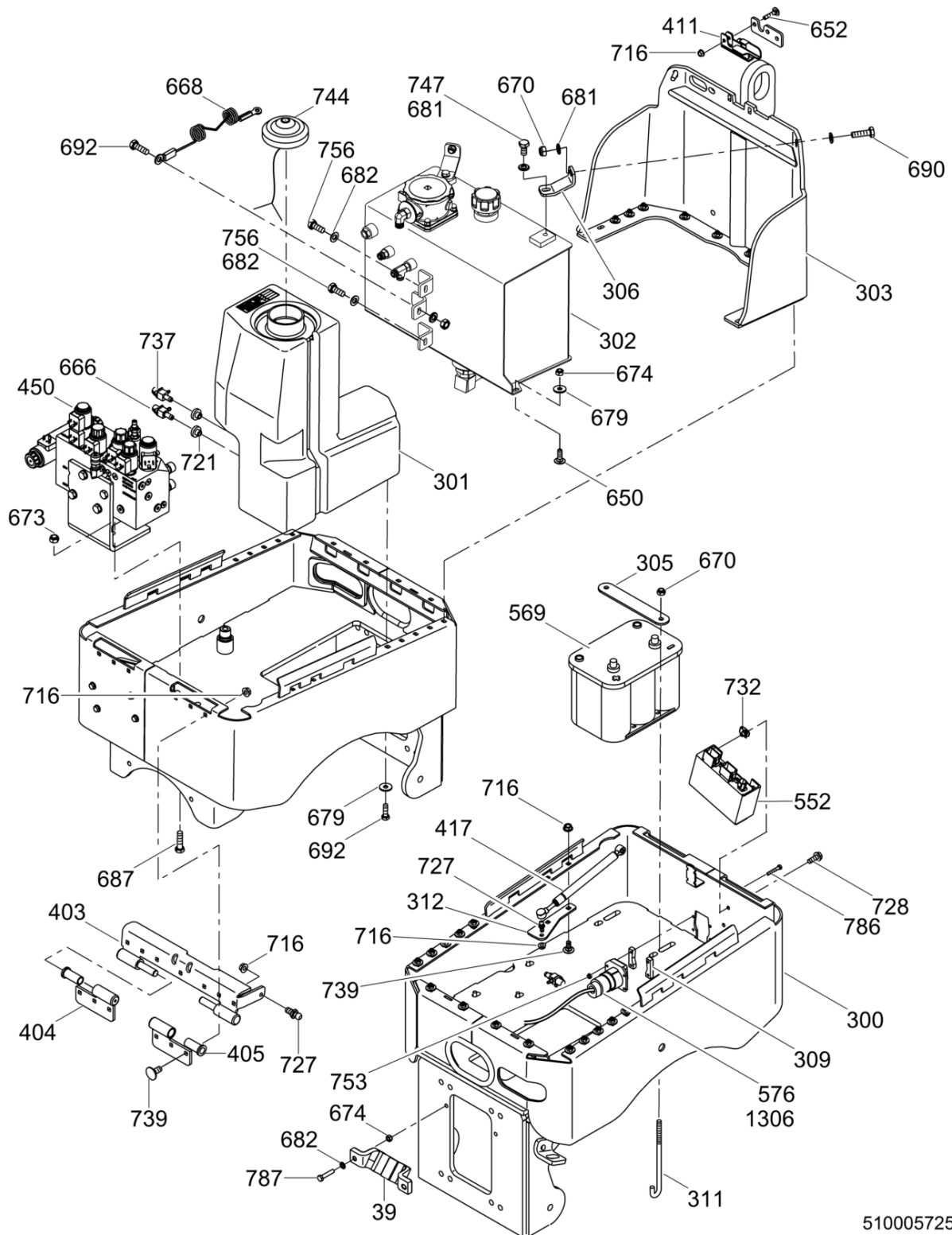

5100057253_01

Pos. Item	Artikel Nr. Item no.	Pc.	Unit	Beschreibung Descripción	Description Description	Abm. Dim.	Norm Standard
						Drehmoment Torque	Schmierstoff Lubricant
682	5000010622	4	pc	Scheibe Arandela	Flat washer Rondelle		
687	5000011420	4	pc	Sechskantschraube Tornillo hexagonal	Hexagonal head cap screw Vis à tête hexagonale	M12 x 45 86Nm/63ft.lbs	DIN933
690	5000011438	2	pc	Sechskantschraube Tornillo hexagonal	Hexagonal head cap screw Vis à tête hexagonale	M10 x 35 49Nm/36ft.lbs	DIN933
692	5000011457	6	pc	Sechskantschraube Tornillo hexagonal	Hexagonal head cap screw Vis à tête hexagonale	M8 x 25 7Nm/5ft.lbs	
716	5000030066	12	pc	Sechskantmutter Contratuerca	Locknut Contre-écrou	M8 7Nm/5ft.lbs	
721	5000053577	2	pc	Tankbuchse Buje	Tank valve bushing Douille		
727	5000155125	2	pc	Gewindebolzen Perno prisionero	Stud Goujon	M8 x 10	
728	5000087023	4	pc	Sechskantflanschsraube Tornillo hexagonal de brida	Hexagonal flange head screw Vis hexagonale de bride	M8 x 22 25Nm/18ft.lbs	
732	5000110969	4	pc	Klemmutter Sujetador	Clip nut Agrafe	M8	
737	5000157189	1	pc	Ventil Válvula	Valve Soupape	3/16in	
739	5000155841	8	pc	Schloßschraube Tornillo de carruaje	Carriage bolt Boulon brut à tête bombée	M8 x 20	
744	5100046509	1	pc	Tankverschluß Tapa del tanque	Fuel tank cap Chapeau de réservoir		
747	5000012364	1	pc	Sechskantschraube Tornillo hexagonal	Hexagonal head cap screw Vis à tête hexagonale	M10 x 20 49Nm/36ft.lbs	DIN 933
753	5000010369	4	pc	Sechskantmutter Tuerca hexagonal	Hexagon nut Écrou hexagonal		
756	5000012362	2	pc	Sechskantschraube Tornillo hexagonal	Hexagonal head cap screw Vis à tête hexagonale	7Nm/5ft.lbs	
786	5000154898	4	pc	Sechskantschraube Tornillo hexagonal	Hexagonal head cap screw Boulon à tête hexagonale	M5 x 30	
867	5000160294	1	pc	Abstandsstück Espaciador	Spacer Entretoise		
1306	5000182304	1	pc	Anschlußsteil Conector	Connector Connecteur		

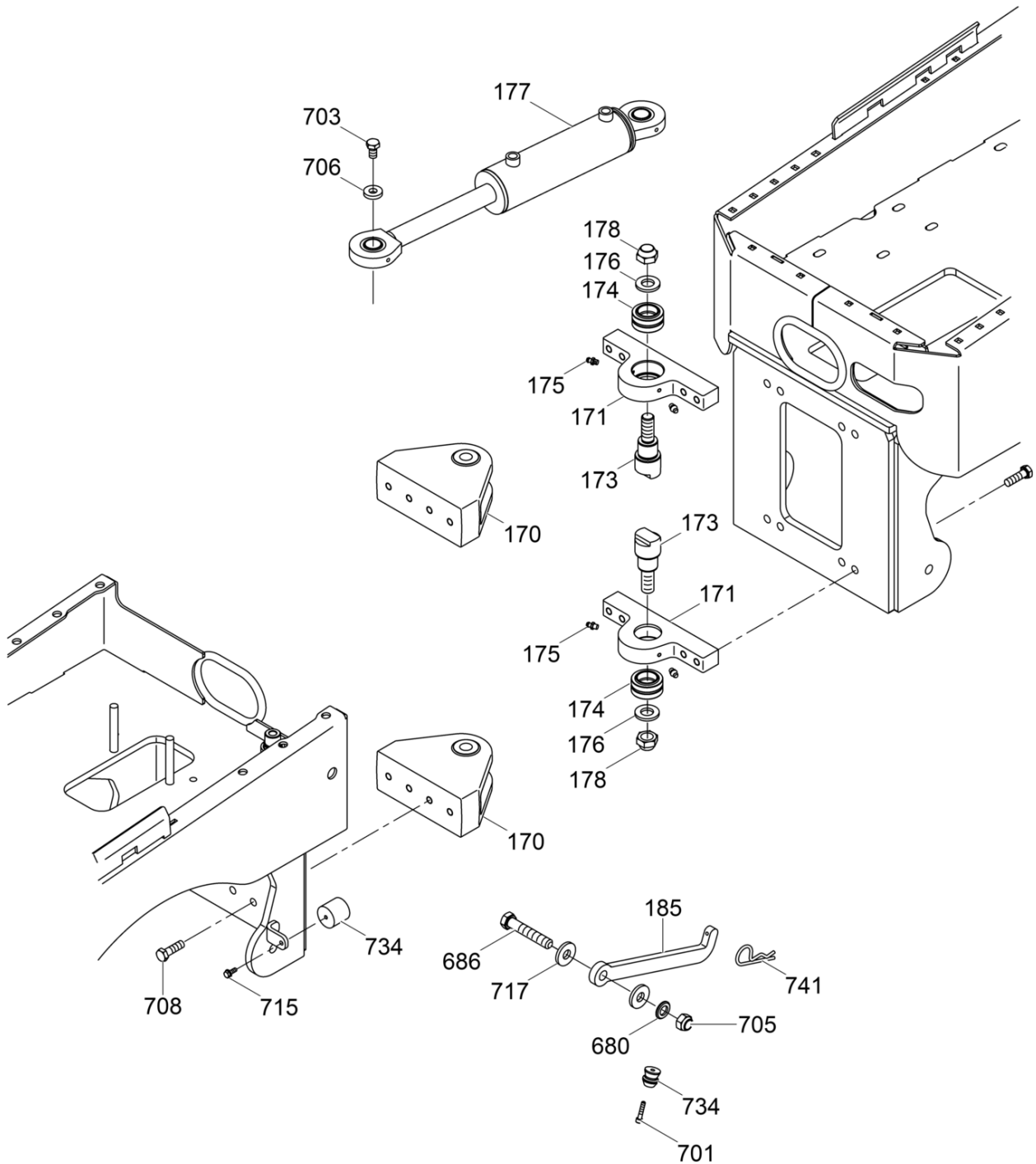

wc_ex0009025100_04

Pos. Item	Artikel Nr. Item no.	Pc.	Unit	Beschreibung Descripción	Description Description	Abm. Dim.	Norm Standard
						Drehmoment Torque	Schmierstoff Lubricant
170	5000115448	2	pc	Drehteil Pivote	Pivot Pivot		
171	5000089323	2	pc	Konsole Soporte	Bracket Support		
173	5000119066	2	pc	Stift Pasador	Pin Goupille		
174	5000079161	2	pc	Kugellager Rodamiento de bolas	Ball bearing Roulement à billes		
175	5002004705	4	pc	Kegelschmiernippel Grasera	Grease fitting Graisseur	AM6	DIN71412
176	5000119067	2	pc	Scheibe Arandela	Washer Rondelle		
177	5000117018	1	pc	Hydrozylinder Cilindro hidráulico	Hydraulic cylinder Cylindre hydraulique		
178	5000017088	2	pc	Sicherungsmutter Contratuerca	Lock nut Contre-écrou	M20	
185	5000119629	1	pc	Riegel Seguro	Lock arm Verrou		
680	5000010618	1	pc	Scheibe Arandela	Flat washer Rondelle	16	ISO7090
686	5000011382	1	pc	Sechskantschraube Tornillo hexagonal	Hexagonal head cap screw Vis à tête hexagonale	M16 x 90 210Nm/155ft.lbs	DIN931
701	5000011549	1	pc	Zylinderschraube Tornillo cilíndrico	Cheese head screw Vis à tête cylindrique	M6 x 30 17Nm/13ft.lbs	ISO4762
703	5000012368	2	pc	Sechskantschraube Tornillo hexagonal	Hexagonal head cap screw Vis à tête hexagonale	M12 x 20 86Nm/63ft.lbs	DIN933
705	5000011382	1	pc	Sechskantschraube Tornillo hexagonal	Hexagonal head cap screw Vis à tête hexagonale	M16 x 90 210Nm/155ft.lbs	DIN931
706	5000013618	2	pc	Scheibe Arandela	Flat washer Rondelle	13	DIN7349
708	5000016434	16	pc	Sechskantschraube Tornillo hexagonal	Hexagonal head cap screw Vis à tête hexagonale	M12 x 40 86Nm/63ft.lbs	
715	5000028949	1	pc	Sechskantflanschschaube Tornillo hexagonal de brida	Hexagonal flange head screw Vis hexagonale de bride	M6 x 16 10Nm/7ft.lbs	
717	5000031121	2	pc	Scheibe Arandela	Washer Rondelle		
734	5000111536	1	pc	Verriegelung Aldaba	Latch Loquet		
741	5002005276	1	pc	Splint Clavija hendida	Cotter pin Goupille fendue	No.3-9/16in	
1274	5000165049	1	pc	Schlauchschutz Protector de manguera	Hose guard Protecteur		

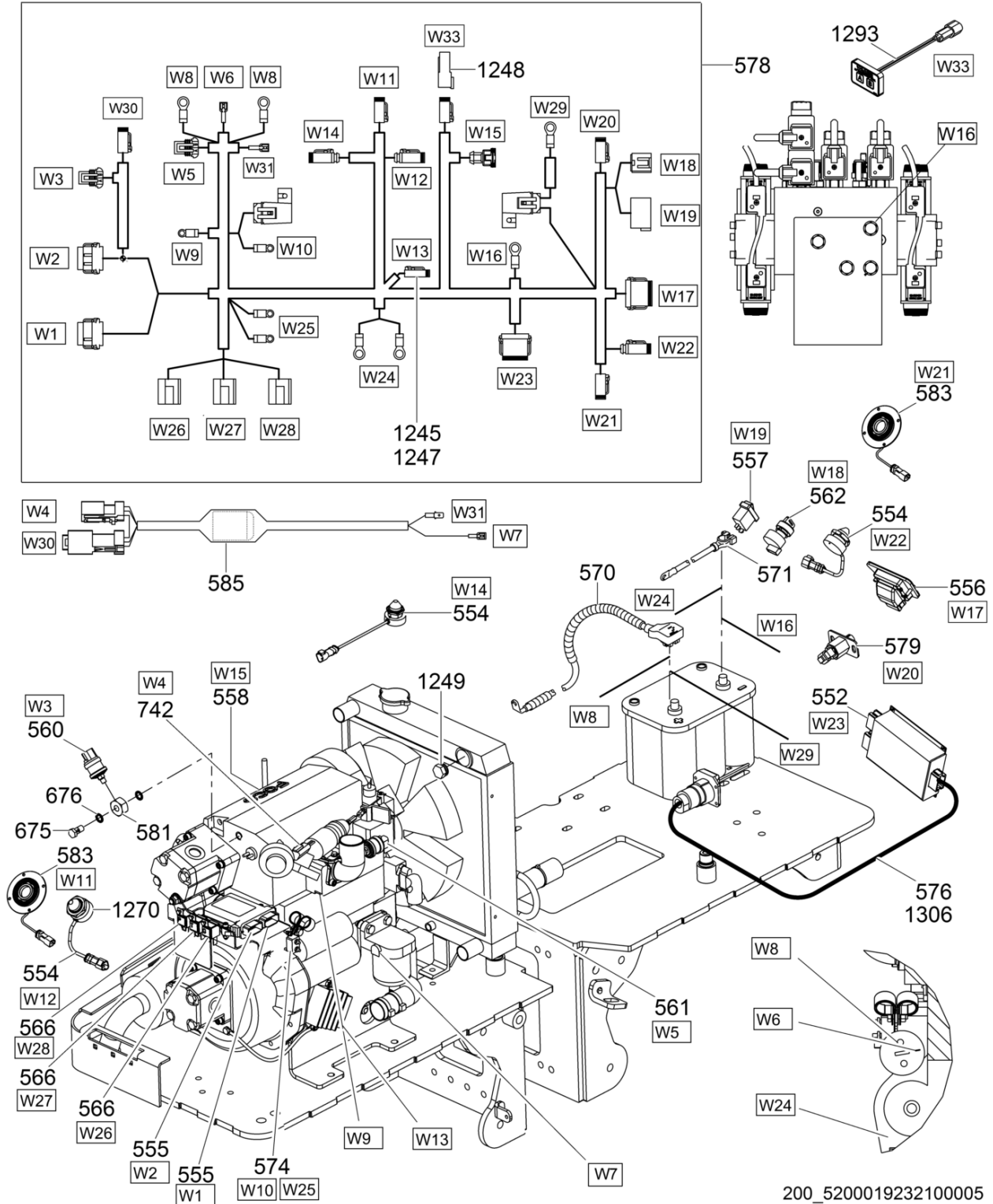

200_5200019232100005

Pos. Item	Artikel Nr. Item no.	Pc.	Unit	Beschreibung Descripción	Description Description	Abm. Dim.	Norm Standard
						Drehmoment Torque	Schmierstoff Lubricant
552	5000165515	1	pc	Decodiermodul Módulo decodificador	Decoder module Module de décodage		
554	5000170949	3	pc	Empfängerauge Receptor de rayos	Infrared sensor Oeil récepteur		
555	5200025080	1	pc	Motorkontrollmodul Módulo de mando del motor	Engine control module Module de contrôle de moteur		
556	5000178862	1	pc	Anzeigemodul Módulo de visualización	Display module Module d'affichage		
557	5000150110	1	pc	Schalter Interruptor	Switch Interrupteur		
558	5000160387	1	pc	Temperatursensoreinheit Unidad de alerta de temperatura	Temperature sensor Appareil d'alerte de températu		
560	5000150113	1	pc	Öldruckschalter Interruptor de presión de aceite	Oil pressure switch Interrupteur à pression d'huile		
561	5000150114	1	pc	Vakuumschalter Interruptor	Vacuum switch Interrupteur à vide		
562	5000150115	1	pc	Zündschalter Interruptor de encendido	Ignition switch Interrupteur d'ignition		
566	5000085437	3	pc	Relais Relai	Relay Relais		
570	5000119292	1	pc	Plusbatteriekabel Cable positivo de batería	Positive battery cable Câble positif de batterie		
571	5000119293	1	pc	Minusbatteriekabel Cable negativo de batería	Negative battery cable Câble négatif de batterie		
574	5000150961	1	pc	Unterbrecher Interruptor de circuito	Circuit breaker Coupe-circuit	50A 12V	
576	5000170950	1	pc	Stecker Und Kabelbaum Kpl. Enchufe y conjunto de cables compl.	Plug and harness cpl. Fiche et harnais de câbles éle		
578	5200020490	1	pc	Kabelbaum Conjunto de cables	Wiring harness Harnais de câbles électriques		
579	5000154405	1	pc	Ladungsanschlussmodul Módulo de toma de carga	Charge port module Module de prise de charge		
581	5000150291	1	pc	Adapter Adaptador	Adapter Raccord		
583	5000154403	2	pc	Lichtringmodul Módulo de anillo de luz	Light ring module Module de l'anneau lumineux		
585	5100031355	1	pc	Kabelbaum Conjunto de cables	Wiring harness Harnais de câbles électriques		
675	5000150116	1	pc	Bolzen Perno	Banjo bolt Boulon	M12	
676	5000150117	2	pc	Scheibe Arandela	Washer Rondelle	M12	
742	5000155486	1	pc	Gasreglerstellteil Actuador de acelerador	Throttle actuator Dispositif de commande des gaz		
1245	5000160840	1	pc	2-Pol Stecker Enchufe	Connector housing, 2 pole,plug Fiche		
1246	5000160841	2	pc	Steckdose Tomacorriente	Receptacle connector Prise de courant		
1247	5000160842	1	pc	Haltekeil Cuña de retención	Lock wedge Cale de fixation		
1248	5000161278	1	pc	Kabelbaum Für Kühlmittelumlauf Conjunto de cables para desviación del enfriador	Coolant bypass wiring harness Harnais de câbles électriques		
1249	5000086983	1	pc	Schraubverschluß Tapón roscado	Plug (threaded) Bouchon		
1270	5000162711	1	pc	Sechskantmutter Tuerca hexagonal	Hexagon nut Écrou hexagonal	M32	

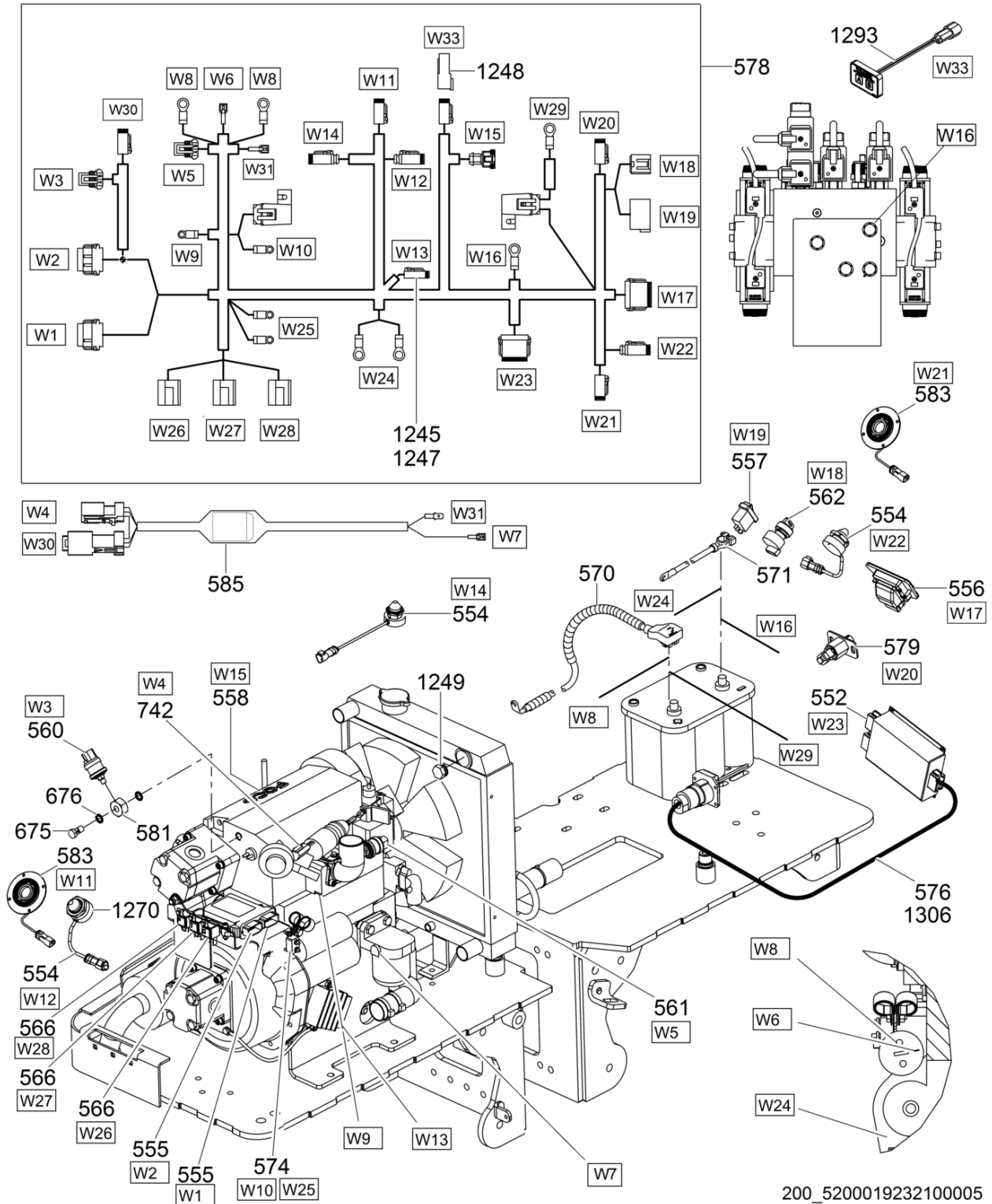

200_5200019232100005

Pos. Item	Artikel Nr. Item no.	Pc.	Unit	Beschreibung Descripción	Description Description	Abm. Dim.	Norm Standard
						Drehmoment Torque	Schmierstoff Lubricant
1293	5000172989	1	pc	Diagnose-Controllermodul Módulo controlador de diagnóstico	Diagnostic control module Module contrôle de diagnostic		
1306	5000182304	1	pc	Anschlußteil Conector	Connector Connecteur		

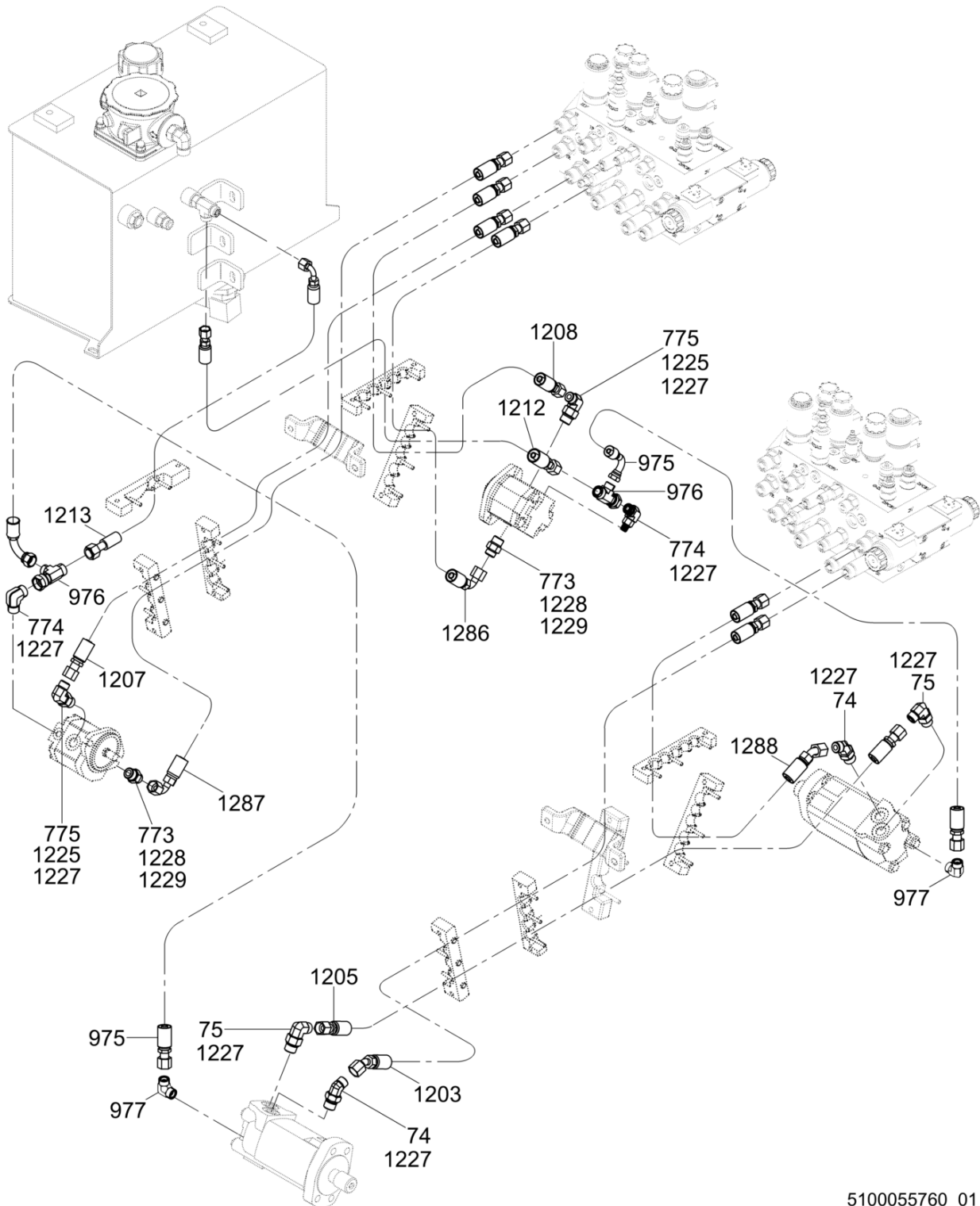

5100055760_01

Pos. Item	Artikel Nr. Item no.	Pc.	Unit	Beschreibung Descripción	Description Description	Abm. Dim.	Norm Standard
						Drehmoment Torque	Schmierstoff Lubricant
74	5000151767	4	pc	Hydraulikrohrkrümmer Codo hidráulico	Hydraulic elbow fitting Coude hydraulique	45	
75	5000081340	2	pc	Rohrkrümmer Codo	Elbow fitting Coude	No.8 x 10 x 90	
773	5000079875	2	pc	Hydraulikverschraubung Unión hidráulico	Hydraulic fitting Raccord hydraulique	No.8 x 10	
774	5000151768	2	pc	Hydraulikrohrkrümmer Codo hidráulico	Hydraulic elbow fitting Coude hydraulique	90	
775	5000081340	2	pc	Rohrkrümmer Codo	Elbow fitting Coude	No.8 x 10 x 90	
975	5100053785	2	pc	Fall Ablaufschlauch Manguera de drenaje de la caja	Case drain hose Case tuyau de vidange		
976	5100053685	2	pc	Hydraulikverschraubung Unión hidráulico	Hydraulic fitting Raccord hydraulique	No.6 ORFS	
977	5000111285	2	pc	Hydraulikrohrkrümmer Codo hidráulico	Hydraulic elbow fitting Coude hydraulique	SAE No.4 x 90	
1203	5200010939	1	pc	Hydraulikschlauch Manguera hidráulica	Hydraulic hose Tuyau hydraulique	1360	
1205	5200010940	1	pc	Hydraulikschlauch Manguera hidráulica	Hydraulic hose Tuyau hydraulique	1275 38Nm/28ft.lbs	
1207	5200006474	1	pc	Hydraulikschlauch Manguera hidráulica	Hydraulic hose Tuyau hydraulique	1470 60Nm/44ft.lbs	
1208	5200006478	1	pc	Hydraulikschlauch Manguera hidráulica	Hydraulic hose Tuyau hydraulique	995 54Nm/40ft.lbs	
1212	5000182222	1	pc	Hydraulikschlauch Manguera hidráulica	Hydraulic hose Tuyau hydraulique	985mm 41Nm/30ft.lbs	
1213	5000182221	1	pc	Hydraulikschlauch Manguera hidráulica	Hydraulic hose Tuyau hydraulique	1525mm 41Nm/30ft.lbs	
1225	5000080731	5	pc	O-Ring Anillo-o	O-ring Joint torique	0,47 x 0,07in #6	
1227	5000080737	16	pc	O-Ring Anillo-o	O-ring Joint torique	0,49 x 0,07in #8 ORFS	
1228	5000080732	8	pc	O-Ring Anillo-o	O-ring Joint torique	0,64 x 0,09in #8	
1229	5000080733	2	pc	O-Ring Anillo-o	O-ring Joint torique	0,76 x 0,10in #10	
1275	5000170004	1	pc	Schutzschlauchsatz Juego de manguera	Protective hose kit Jue de tuyau		
1286	5200006554	1	pc	Hydraulikschlauch Manguera hidráulica	Hydraulic hose Tuyau hydraulique	60Nm/44ft.lbs	
1287	5200006476	1	pc	Hydraulikschlauch Manguera hidráulica	Hydraulic hose Tuyau hydraulique	1510	
1288	5100014108	1	pc	Hydraulikschlauch Manguera hidráulica	Hydraulic hose Tuyau hydraulique	1060mm	

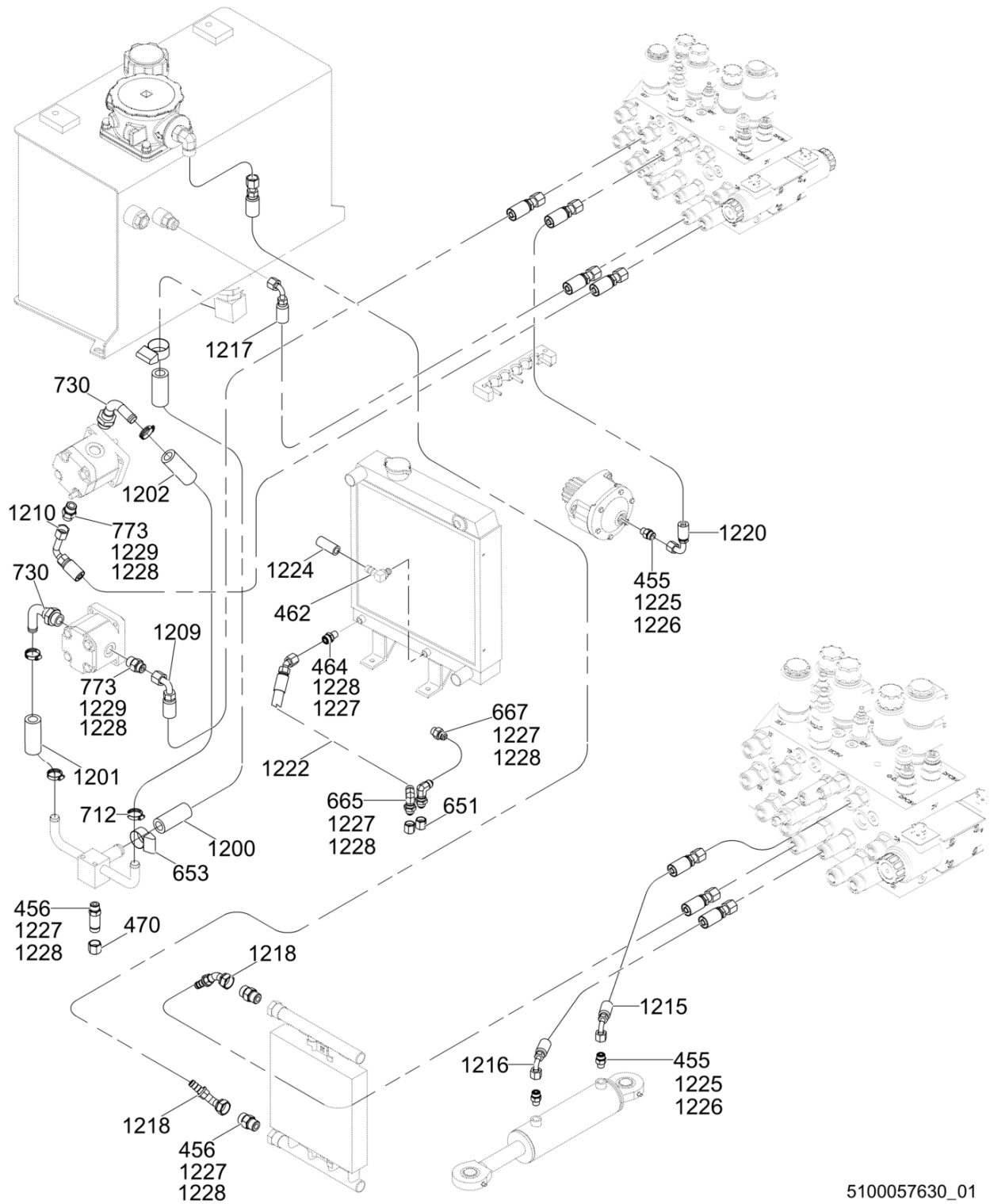

5100057630_01

Pos. Item	Artikel Nr. Item no.	Pc.	Unit	Beschreibung Descripción	Description Description	Abm. Dim.	Norm Standard
						Drehmoment Torque	Schmierstoff Lubricant
455	5000078816	3	pc	Zwischenverschraubung Unión con adaptador	Adapter fitting Raccord intermédiaire		
456	5000158572	2	pc	Verschraubung Unión	Fitting Raccord	No.8	
462	5000156401	1	pc	Rohrkrümmer Codo	Elbow fitting Raccord coudé	90	
464	5000156204	1	pc	Verschraubung Unión	Fitting Raccord	No.8-3/8 NPT	
470	5000111716	1	pc	Verschraubung, Kappe Unión, tapa	Fitting cap Raccord, capuchon	No.8	
651	5000119929	2	pc	Verschraubung, Kappe Unión, tapa	Fitting cap Raccord, capuchon	No.8	
653	5000150051	2	pc	Schlauchschelle Abrazaderas de manguera	Hose clamp Agrafe de tuyau	No.16	
665	5000119960	2	pc	Verschraubung Unión	Fitting Raccord	No.8	
667	5000119962	1	pc	Verschraubung Unión	Fitting Raccord	No.8	
712	5000028314	4	pc	Schelle Abrazadera	Clamp Agrafe	0,81 x 1,25in	
730	5000088342	2	pc	Verschraubung Unión	Fitting Raccord	90	
773	5000079875	2	pc	Hydraulikverschraubung Unión hidráulico	Hydraulic fitting Raccord hydraulique	No.8 x 10	
1200	5000119663	1	pc	Hydraulikschlauch Manguera hidráulica	Hydraulic hose Tuyau hydraulique	1135	
1201	5000119664	1	pc	Hydraulikschlauch Manguera hidráulica	Hydraulic hose Tuyau hydraulique	115	
1202	5000119665	1	pc	Hydraulikschlauch Manguera hidráulica	Hydraulic hose Tuyau hydraulique	570	
1209	5000182643	1	pc	Hydraulikschlauch Manguera hidráulica	Hydraulic hose Tuyau hydraulique	1665mm 60Nm/44ft.lbs	
1210	5000182644	1	pc	Hydraulikschlauch Manguera hidráulica	Hydraulic hose Tuyau hydraulique	1880mm 60Nm/44ft.lbs	
1215	5000182223	1	pc	Hydraulikschlauch Manguera hidráulica	Hydraulic hose Tuyau hydraulique	285mm 41Nm/30ft.lbs	
1216	5000182636	1	pc	Hydraulikschlauch Manguera hidráulica	Hydraulic hose Tuyau hydraulique	450mm	
1217	5000182224	1	pc	Hydraulikschlauch Manguera hidráulica	Hydraulic hose Tuyau hydraulique	425mm 41Nm/30ft.lbs	
1218	5000164955	2	pc	Hydraulikschlauch Manguera hidráulica	Hydraulic hose Tuyau hydraulique		
1220	5000182225	1	pc	Hydraulikschlauch Manguera hidráulica	Hydraulic hose Tuyau hydraulique	590mm 41Nm/30ft.lbs	
1222	5000119684	1	pc	Abflussschlauch Manguera de salida	Drain hose Tuyau d'écoulement	855	
1224	5000119934	1	pc	Abflussschlauch Manguera de salida	Drain hose Tuyau d'écoulement	570	
1225	5000080731	5	pc	O-Ring Anillo-o	O-ring Joint torique	0,47 x 0,07in #6	
1226	5000080736	3	pc	O-Ring Anillo-o	O-ring Joint torique	0,36 x 0,07in #6 ORFS	
1227	5000080737	16	pc	O-Ring Anillo-o	O-ring Joint torique	0,49 x 0,07in #8 ORFS	
1228	5000080732	8	pc	O-Ring Anillo-o	O-ring Joint torique	0,64 x 0,09in #8	

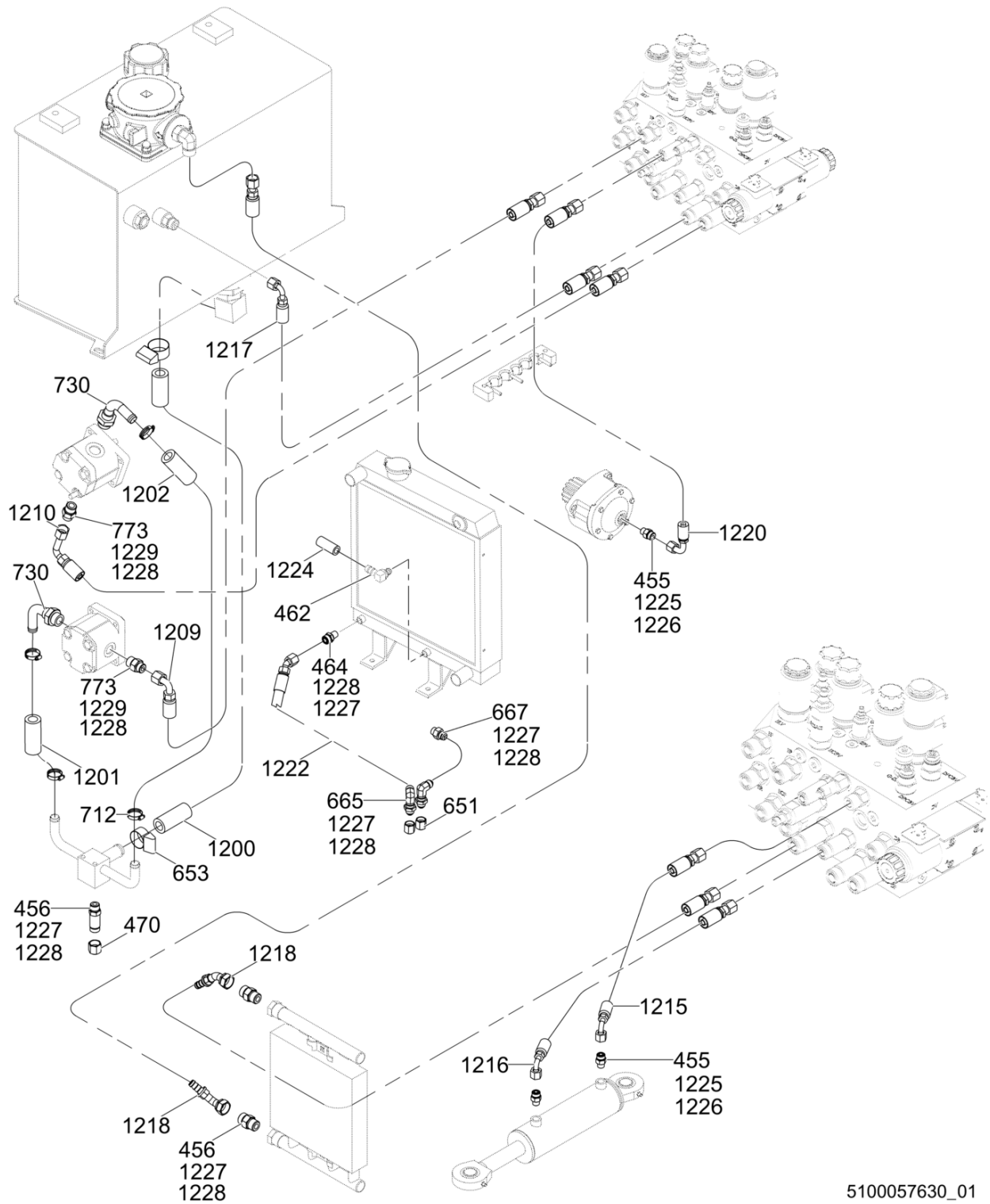

5100057630_01

Pos. Item	Artikel Nr. Item no.	Pc.	Unit	Beschreibung Descripción	Description Description	Abm. Dim.	Norm Standard
						Drehmoment Torque	Schmierstoff Lubricant
1229	5000080733	2	pc	O-Ring Anillo-o	O-ring Joint torique	0,76 x 0,10in #10	
1275	5000170004	1	pc	Schutzschlauchsatz Juego de manguera	Protective hose kit Jue de tuyau		

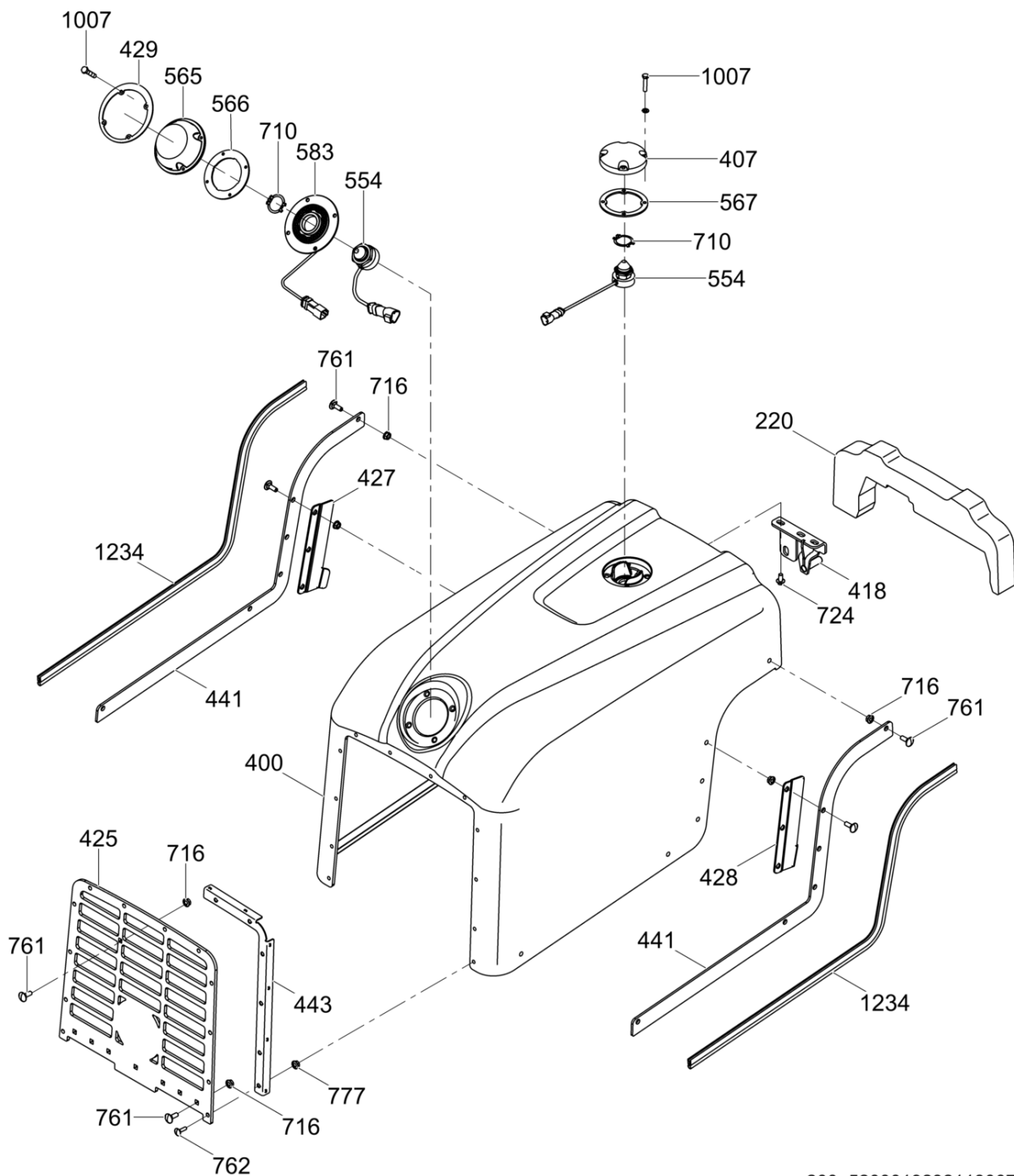

200_5200019232113007

Pos. Item	Artikel Nr. Item no.	Pc.	Unit	Beschreibung Descripción	Description Description	Abm. Dim.	Norm Standard
						Drehmoment Torque	Schmierstoff Lubricant
220	5000150227	1	pc	Dichtung Empaque	Seal Joint		
220	5200019759	1	pc	Profilgummi Moldura	Trim seal Garniture		
400	5200017704	1	pc	Vorderdeckel Tapa delantera	Front cover Couvercle avant		
407	5200018182	1	pc	Kappe Tapa	Cap Capuchon		
418	5200019751	1	pc	Konsole Soporte	Bracket Support		
425	5200019770	1	pc	Gitter Rejilla	Grille cover Grille		
427	5200019757	1	pc	Konsole (Links) Soporte (izquierda)	Lh bracket Support (gauche)		
428	5200019758	1	pc	Konsole (Rechts) Soporte (derecha)	Rh bracket Support (droite)		
429	5200019775	1	pc	Konsole Ménsula	Mount Support		
441	5200019755	2	pc	Konsole Soporte	Bracket Support		
443	5200019774	1	pc	Konsole Soporte	Bracket Support		
554	5000170949	2	pc	Empfängerauge Receptor de rayos	Infrared sensor Oeil récepteur		
565	5200011851	1	pc	Kappe Tapa	Cap Capuchon		
566	5100026695	1	pc	Dichtung Junta	Gasket Joint		
567	5100026696	1	pc	Dichtung Junta	Gasket Joint		
583	5100042609	1	pc	Lichtringmodul Módulo de anillo de luz	Light ring module Module de l'anneau lumineux		
710	5000172857	2	pc	Scheibe Arandela	Retaining washer Rondelle		
716	5000030066	20	pc	Sechskantmutter Contratuerca	Locknut Contre-écrou	M8	
724	5000155839	3	pc	Sechskantschraube Tornillo hexagonal	Hexagonal head cap screw Boulon à tête hexagonale	M8 x 16	
761	5000163950	20	pc	Schloßschraube Tornillo de carruaje	Carriage bolt Boulon brut à tête bombée	M8 x 25	
762	5000164579	12	pc	Schloßschraube Tornillo de carruaje	Carriage bolt Boulon brut à tête bombée	M6 x 25	
777	5000029117	12	pc	Sicherungsmutter Contratuerca	Lock nut Contre-écrou	M6	
1007	5000011474	8	pc	Sechskantschraube Tornillo hexagonal	Hexagonal head cap screw Vis à tête hexagonale	M5 x 25 6Nm/4ft.lbs	DIN933
1234	5000159561	2	pc	Profilgummi Moldura	Seal-trim Garniture	1000	

Pos. Item	Artikel Nr. Item no.	Pc.	Unit	Beschreibung Descripción	Description Description	Abm. Dim.	Norm Standard
						Drehmoment Torque	Schmierstoff Lubricant
408	5200018183	1	pc	Bedienungskonsole Pupitre de mando	Console Panneau de contrôle		
433	5200019786	1	pc	Zunge Orejeta	Tab Onglet		
444	5200019779	1	pc	Konsole Ménsula	Mount Support		
445	5200019784	1	pc	Konsole Soporte	Bracket Support		
446	5000153425	1	pc	Handbuchhalter Soporte manual	Manual holder Support de manuel		
447	5000170979	1	pc	Türverriegelung Aldaba de puerta	Door latch Loquet de porte		
553	5000165514	1	pc	Sender Transmisor	Transmitter module Transmetteur		
554	5000170949	2	pc	Empfängerauge Receptor de rayos	Infrared sensor Oeil récepteur		
556	5000178862	1	pc	Anzeigemodul Módulo de visualización	Display module Module d'affichage		
557	5000150110	1	pc	Schalter Interruptor	Switch Interrupteur		
562	5000150115	1	pc	Zündschalter Interruptor de encendido	Ignition switch Interrupteur d'ignition		
565	5200011851	1	pc	Kappe Tapa	Cap Capuchon		
566	5100026695	1	pc	Dichtung Junta	Gasket Joint		
577	5000154417	1	pc	Ladungskabel Cable de carga	Charging cable Câble de charge		
579	5000178854	1	pc	Ladungsanschlussmodul Módulo de toma de carga	Charge port module Module de prise de charge		
583	5100042609	1	pc	Lichtringmodul Módulo de anillo de luz	Light ring module Module de l'anneau lumineux		
674	5000010367	4	pc	Sechskantmutter Tuerca hexagonal	Hexagon nut Écrou hexagonal	M8	DIN985
677	5000010368	2	pc	Sechskantmutter Tuerca hexagonal	Hexagon nut Écrou hexagonal	M6	DIN985
678	5000010624	2	pc	Scheibe Arandela	Flat washer Rondelle		
682	5000010622	2	pc	Scheibe Arandela	Flat washer Rondelle		
710	5000172857	1	pc	Scheibe Arandela	Retaining washer Rondelle		
724	5000155839	3	pc	Sechskantschraube Tornillo hexagonal	Hexagonal head cap screw Boulon à tête hexagonale	M8 x 16	
753	5000010369	1	pc	Sechskantmutter Tuerca hexagonal	Hexagon nut Écrou hexagonal		
761	5000163950	4	pc	Schloßschraube Tornillo de carruaje	Carriage bolt Boulon brut à tête bombée	M8 x 25	
762	5000164579	2	pc	Schloßschraube Tornillo de carruaje	Carriage bolt Boulon brut à tête bombée	M6 x 25	
764	5000012356	4	pc	Sechskantschraube Tornillo hexagonal	Hexagonal head cap screw Vis à tête hexagonale	M6 x 10 10Nm/7ft.lbs	DIN933
765	5200020974	13	pc	Sechskantflanschschaube Tornillo hexagonal de brida	Hexagonal flange head screw Vis hexagonale de bride	M6 x 20 10Nm/7ft.lbs	
766	5000010372	1	pc	Scheibe Arandela	Flat washer Rondelle	B5,3	DIN9021

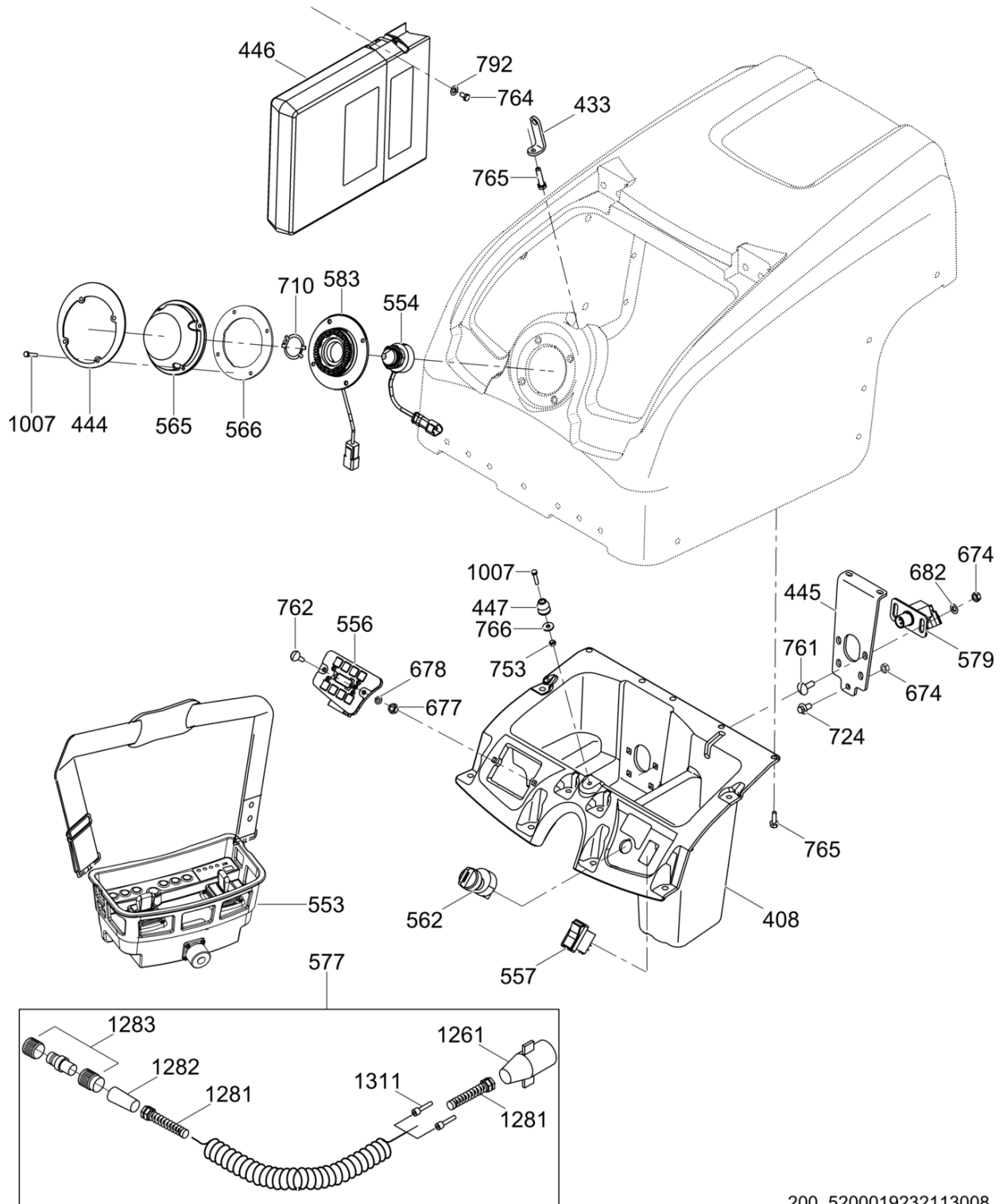

200_5200019232113008

Pos. Item	Artikel Nr. Item no.	Pc.	Unit	Beschreibung Descripción	Description Description	Abm. Dim.	Norm Standard
						Drehmoment Torque	Schmierstoff Lubricant
792	5000010373	4	pc	Scheibe Arandela	Flat washer Rondelle	6	ISO7093
1007	5000011474	5	pc	Sechskantschraube Tornillo hexagonal	Hexagonal head cap screw Vis à tête hexagonale	M5 x 25 6Nm/4ft.lbs	DIN933
1261	5000164490	1	pc	9-Stift Anschlussstecker Enchufe de (9 agujas)	Plug connector (9 pin) Fiche à (9 broches)		
1281	5000089676	2	pc	Zugentlastung Alivio de esfuerzos	Strain relief Effort à la décharge		
1282	5000088821	1	pc	Adapter Adaptador	Adaptor Adaptateur		
1283	5000116889	1	pc	Stopfen Kpl. Tapón compl	Plug cpl. Bouchon compl		
1311	5100037420	2	pc	Stiftklemme Terminal de pasador	Pin terminal Epingle terminal		

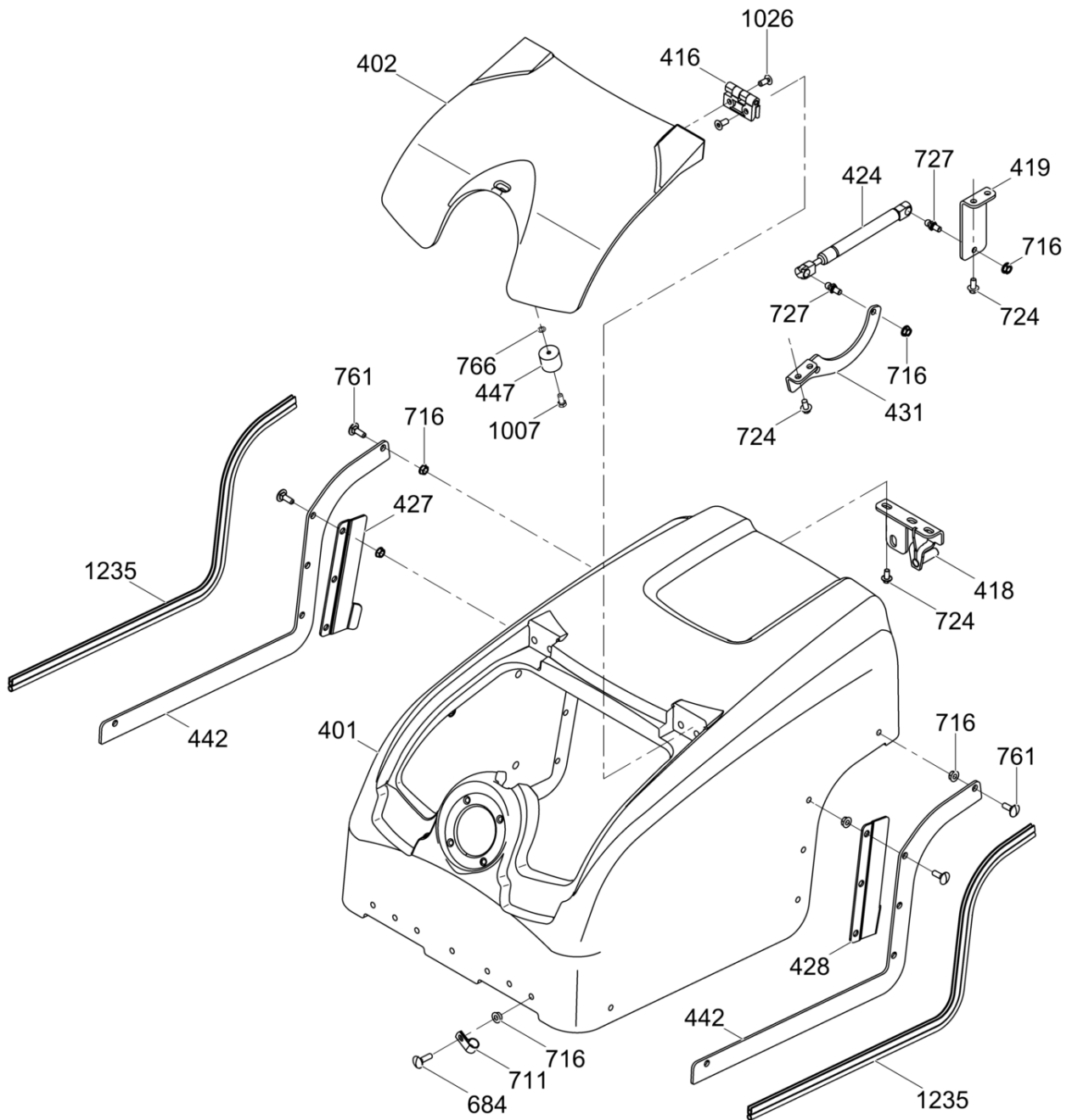

200_5200019232100009

Pos. Item	Artikel Nr. Item no.	Pc.	Unit	Beschreibung Descripción	Description Description	Abm. Dim.	Norm Standard
						Drehmoment Torque	Schmierstoff Lubricant
401	5200017705	1	pc	Hinterdeckel Tapa de atrás	Rear cover Couvercle arrière		
402	5200017707	1	pc	Abdeckplatte Tapa de acceso	Access cover Couvercle à accès		
416	5000154400	2	pc	Scharnier Bisagra	Hinge Charnière		
418	5200019751	1	pc	Konsole Soporte	Bracket Support		
419	5200019783	1	pc	Konsole Soporte	Bracket Support		
424	5000154401	1	pc	Zylinder Cilindro	Cylinder Cylindre		
427	5200019757	1	pc	Konsole (Links) Soporte (izquierda)	Lh bracket Support (gauche)		
428	5200019758	1	pc	Konsole (Rechts) Soporte (derecha)	Rh bracket Support (droite)		
431	5200019785	1	pc	Hebebügel Ménsula alzadora	Lifting bracket Support de relèvement		
442	5200019756	2	pc	Konsole Soporte	Bracket Support		
447	5000170979	1	pc	Türverriegelung Aldaba de puerta	Door latch Loquet de porte		
684	5000011151	7	pc	Schloßschraube Tornillo de carruaje	Carriage bolt Boulon brut à tête bombée	M8 x 30	DIN603
711	5000163956	1	pc	Schelle Abrazadera	Clamp Agrafe		
711	5000163957	1	pc	Rohrschelle Abrazadera para mangueras	Tube clamp Agrafe pour tuyaux souples	5/16in ID	
716	5000030066	19	pc	Sechskantmutter Contratuerca	Locknut Contre-écrou	M8	
724	5000155839	7	pc	Sechskantschraube Tornillo hexagonal	Hexagonal head cap screw Boulon à tête hexagonale	M8 x 16	
727	5000155125	1	pc	Gewindebolzen Perno prisionero	Stud Goujon	M8 x 10	
727	5000155125	2	pc	Gewindebolzen Perno prisionero	Stud Goujon	M8 x 10	
761	5000163950	10	pc	Schloßschraube Tornillo de carruaje	Carriage bolt Boulon brut à tête bombée	M8 x 25	
766	5000010372	1	pc	Scheibe Arandela	Flat washer Rondelle	B5,3	DIN9021
1007	5000011474	1	pc	Sechskantschraube Tornillo hexagonal	Hexagonal head cap screw Vis à tête hexagonale	M5 x 25 6Nm/4ft.lbs	DIN933
1026	5000021563	8	pc	Senkschraube Tornillo avellanado	Countersunk screw Vis noyée	M8 x 20 25Nm/18ft.lbs	ISO10642
1235	5000159562	2	pc	Profilgummi Moldura	Seal-trim Garniture	822	

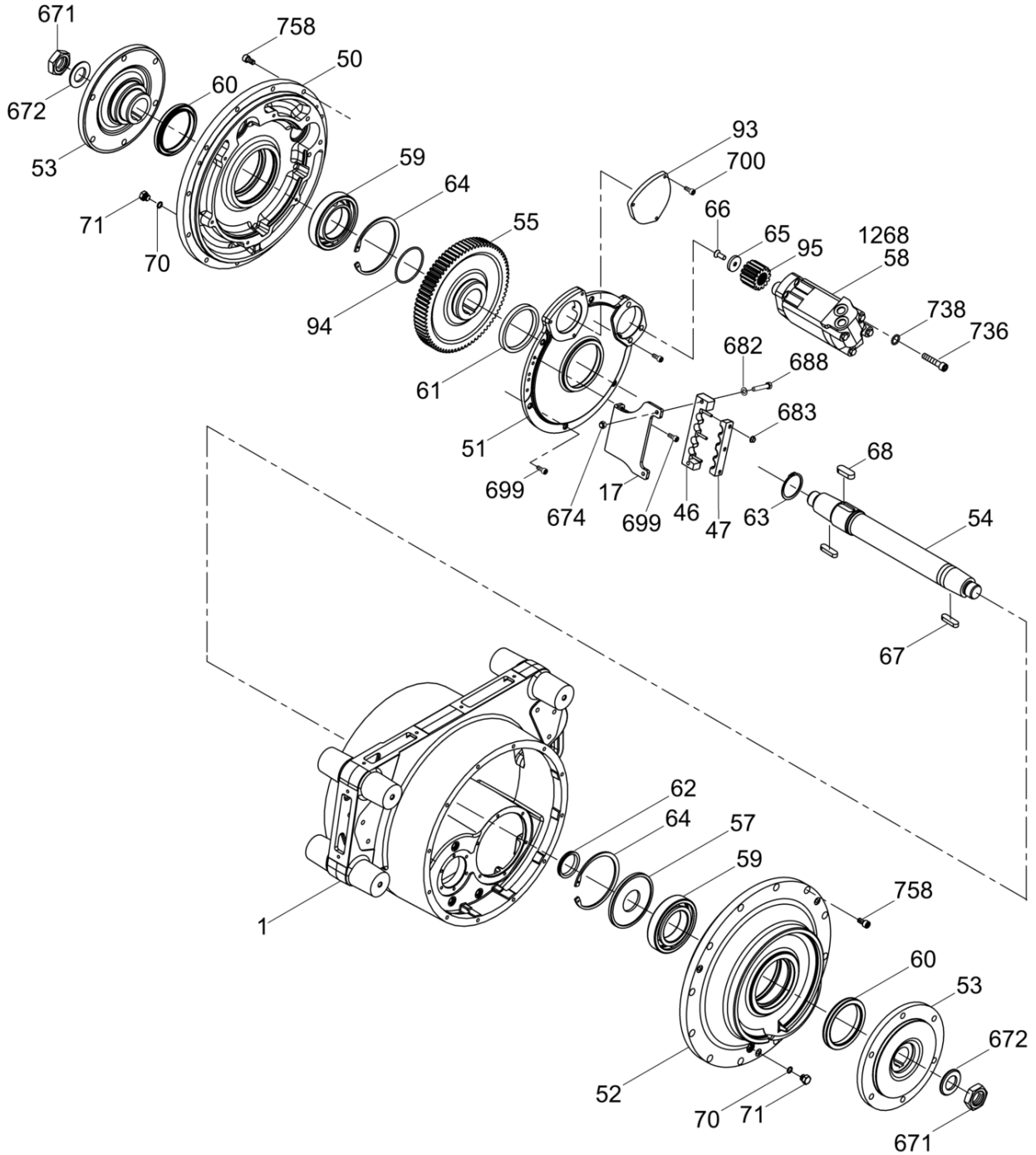

5200011104_02

Pos. Item	Artikel Nr. Item no.	Pc.	Unit	Beschreibung Descripción	Description Description	Abm. Dim.	Norm Standard
						Drehmoment Torque	Schmierstoff Lubricant
1	5000116902	1	pc	Bandagenträger Soporte del tambor	Drum support Support de tambour		
17	5200007278	1	pc	Konsole Soporte	Bracket Support		
46	5000150252	1	pc	Schlauchschelle Abrazaderas de manguera	Hose clamp Agrafe de tuyau		
47	5000150253	1	pc	Schlauchschelle Abrazaderas de manguera	Hose clamp Agrafe de tuyau		
50	5000118366	1	pc	Deckel Tapa	Cover Couvercle		
51	5000118368	1	pc	Deckel Tapa	Cover Couvercle		
52	5000116903	1	pc	Deckel Tapa	Cover Couvercle		
53	5000116906	2	pc	Bandagennabe Maza de tambor	Drum hub Moyeu de tambour		
54	5000116907	1	pc	Antriebswelle Eje motor	Drive shaft Arbre d'entraînement		
55	5000119284	1	pc	Zahnrad Engranaje	Gear Engrenage		
57	5000118796	1	pc	Scheibe Disco	Disc Disque		
58	5000181899	1	pc	Antriebsmotor Motor de accionamiento	Drive motor Moteur d'entraînement		
59	5000082961	2	pc	Rollenlager Rodamiento de rodillos	Roller bearing Roulement à rouleaux		
60	5000119285	2	pc	Dichtung Empaque	Seal Joint		
61	5000116874	1	pc	Wellendichtring Sello del eje	Shaft seal Bague d'étanchéité	100 x 120 x 12	
62	5000119286	1	pc	Wellendichtring Sello del eje	Shaft seal Bague d'étanchéité		
63	5000116869	1	pc	Sicherungsring Anillo de retención	Retaining ring Bague d'arrêt	62 x 2	DIN471
64	5000044706	2	pc	Sicherungsring Anillo de retención	Retaining ring Bague d'arrêt	140 x 4	DIN472
65	5000080666	1	pc	Scheibe Arandela	Washer Rondelle		
66	5000080667	1	pc	Schraube Tornillo	Screw Vis	3/8-16 x 1in	
67	5000116872	2	pc	Passfeder Chaveta	Square key Clavette	A14 x 9 x 50	DIN6885
68	5000116873	1	pc	Passfeder Chaveta	Square key Clavette	A18 x 11 x 50	DIN6885
70	5000014398	2	pc	O-Ring Anillo-o	O-ring Joint torique	12 x 2	
71	5000078269	2	pc	Schraubverschluss Tapón roscado	Plug (threaded) Bouchon	9/16-18in	
93	5000119505	1	pc	Platte Placa	Plate Plaque		
94	5000152276	1	pc	O-Ring Anillo-o	O-ring Joint torique	81,92 x 5,33	
95	5000154482	1	pc	Ritzel Piñon diferencial	Pinion gear Pignon		
671	5000116871	2	pc	Mutter Tuerca	Nut Écrou	M36 x 3 825Nm/609ft.lbs	

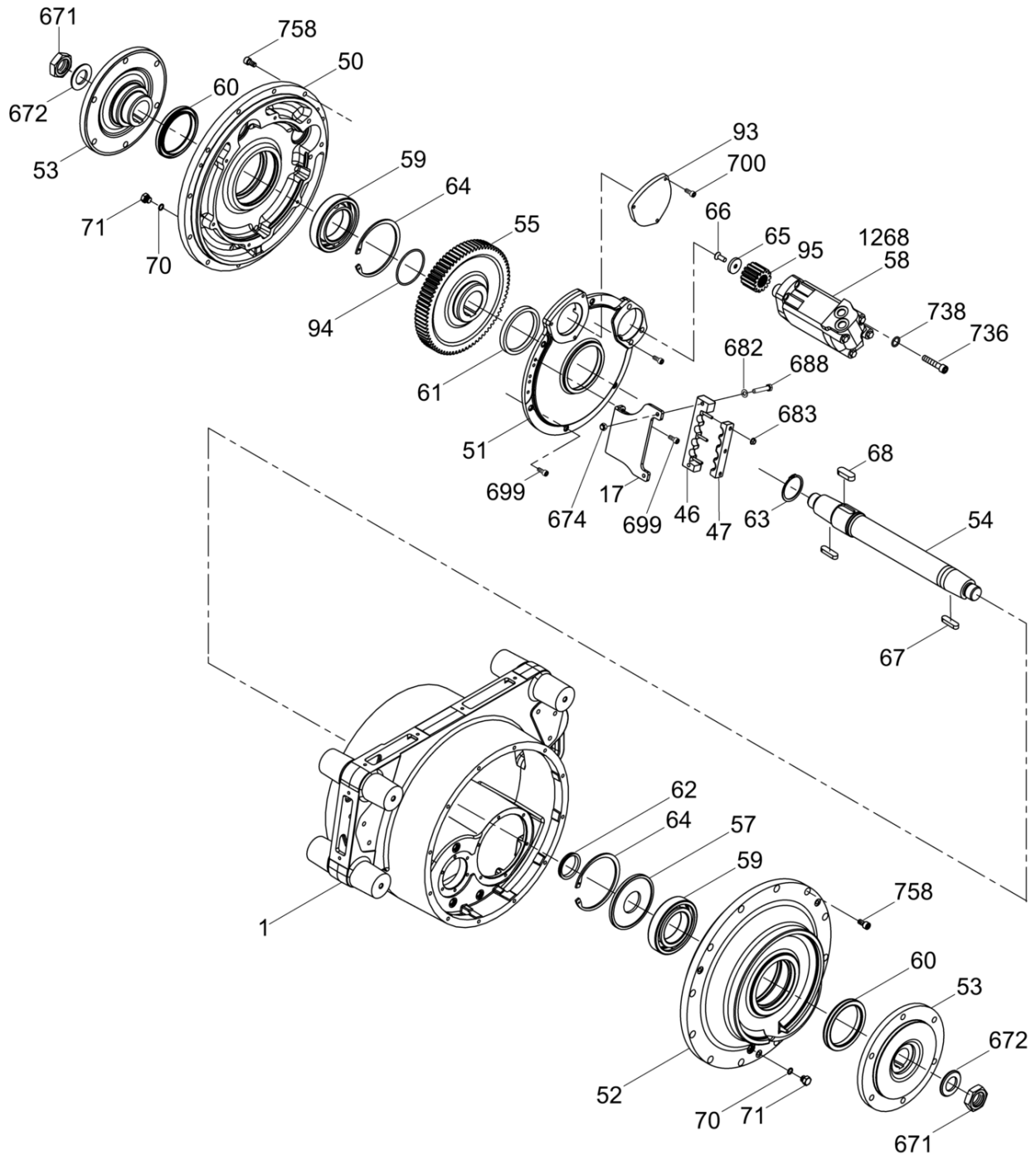

5200011104_02

Pos. Item	Artikel Nr. Item no.	Pc.	Unit	Beschreibung Descripción	Description Description	Abm. Dim.	Norm Standard
						Drehmoment Torque	Schmierstoff Lubricant
672	5000150020	2	pc	Scheibe Arandela	Washer Rondelle	M36	
674	5000010367	2	pc	Sechskantmutter Tuerca hexagonal	Hexagon nut Écrou hexagonal	M8	DIN985
682	5000010622	2	pc	Scheibe Arandela	Flat washer Rondelle		
683	5000155519	3	pc	Flanschmutter Tuerca de reborde	Flange nut Ecrou de bride	M6	DIN 1661
688	5000117969	2	pc	Sechskantschraube Tornillo hexagonal	Hexagonal head cap screw Boulon à tête hexagonale	M8 x 45 25Nm/18ft.lbs	
699	5000011543	8	pc	Zylinderschraube Tornillo hueco	Socket head screw Vis à six-pans creux	M8 x 20 25Nm/18ft.lbs	ISO4762
700	5000011544	3	pc	Zylinderschraube Tornillo cilíndrico	Cheese head screw Vis à tête cylindrique	M8 x 16 41Nm/30ft.lbs	ISO4762
736	5100042214	3	pc	Zylinderschraube Tornillo cilíndrico	Socket head cap screw Vis à tête cylindrique	M12 x 60 85Nm/63ft.lbs	
738	5100055829	3	pc	Scheibe 13, FLACH, 300HV Arandela 13, plana, 300hv	Washer 13,flat,300hv Rondella 13, piatta, 300hv		
758	5000072758	30	pc	Zylinderschraube Tornillo cilíndrico	Cheese head screw Vis à tête cylindrique	M10 x 20 49Nm/36ft.lbs	ISO4762
1268	5000182756	1	pc	Dichtungssatz Juego-empaque	Seal kit Jeu-joint		

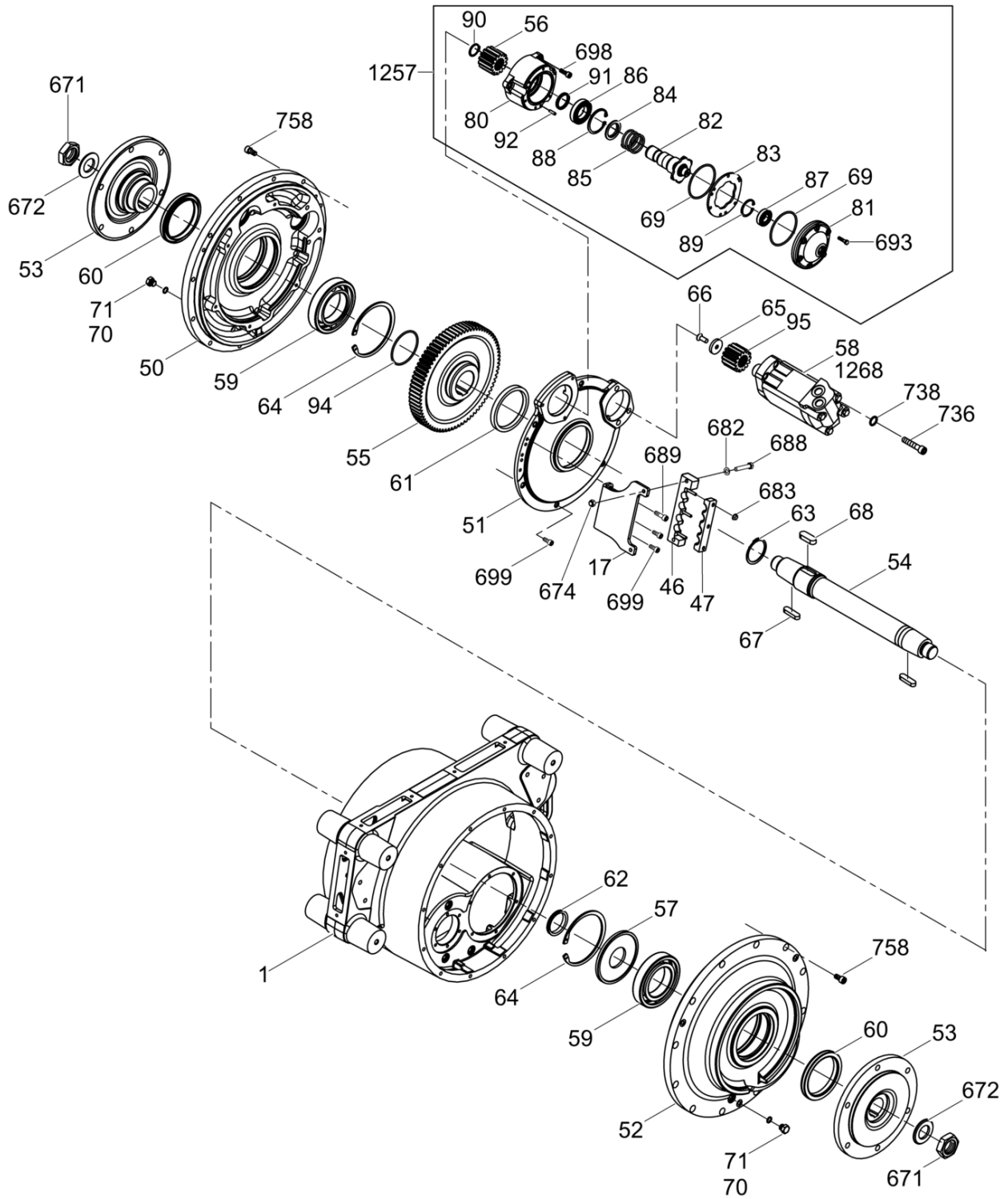

5100011103_02

Pos. Item	Artikel Nr. Item no.	Pc.	Unit	Beschreibung Descripción	Description Description	Abm. Dim.	Norm Standard
						Drehmoment Torque	Schmierstoff Lubricant
1	5000116902	1	pc	Bandagenträger Soporte del tambor	Drum support Support de tambour		
17	5200007278	1	pc	Konsole Soporte	Bracket Support		
40	5200008651	1	pc	Schelle Abrazadera	Clamp Agrafe		
41	5200008650	1	pc	Schelle Abrazadera	Clamp Agrafe		
50	5000118366	1	pc	Deckel Tapa	Cover Couvercle		
51	5000118368	1	pc	Deckel Tapa	Cover Couvercle		
52	5000116903	1	pc	Deckel Tapa	Cover Couvercle		
53	5000116906	2	pc	Bandagennabe Maza de tambor	Drum hub Moyeu de tambour		
54	5000116907	1	pc	Antriebswelle Eje motor	Drive shaft Arbre d'entraînement		
55	5000119284	1	pc	Zahnrad Engranaje	Gear Engrenage		
56	5000116909	1	pc	Ritzel Piñon diferencial	Pinion gear Pignon		
57	5000118796	1	pc	Scheibe Disco	Disc Disque		
58	5000181899	1	pc	Antriebsmotor Motor de accionamiento	Drive motor Moteur d'entraînement		
59	5000082961	2	pc	Rollenlager Rodamiento de rodillos	Roller bearing Roulement à rouleaux		
60	5000119285	2	pc	Dichtung Empaque	Seal Joint		
61	5000116874	1	pc	Wellendichtring Sello del eje	Shaft seal Bague d'étanchéité	100 x 120 x 12	
62	5000119286	1	pc	Wellendichtring Sello del eje	Shaft seal Bague d'étanchéité		
63	5000116869	1	pc	Sicherungsring Anillo de retención	Retaining ring Bague d'arrêt	62 x 2	DIN471
64	5000044706	2	pc	Sicherungsring Anillo de retención	Retaining ring Bague d'arrêt	140 x 4	DIN472
65	5000080666	1	pc	Scheibe Arandela	Washer Rondelle		
66	5000080667	1	pc	Schraube Tornillo	Screw Vis	3/8-16 x 1in	
67	5000116872	2	pc	Passfeder Chaveta	Square key Clavette	A14 x 9 x 50	DIN6885
68	5000116873	1	pc	Passfeder Chaveta	Square key Clavette	A18 x 11 x 50	DIN6885
69	5000119329	3	pc	O-Ring Anillo-o	O-ring Joint torique	85,32 x 3,53	
70	5000014398	2	pc	O-Ring Anillo-o	O-ring Joint torique	12 x 2	
71	5000078269	2	pc	Schraubverschluß Tapón roscado	Plug (threaded) Bouchon	9/16-18in	
80	5000119377	1	pc	Gehäuse Caja	Housing Carter		
81	5000117564	1	pc	Deckel Tapa	Cover Couvercle		

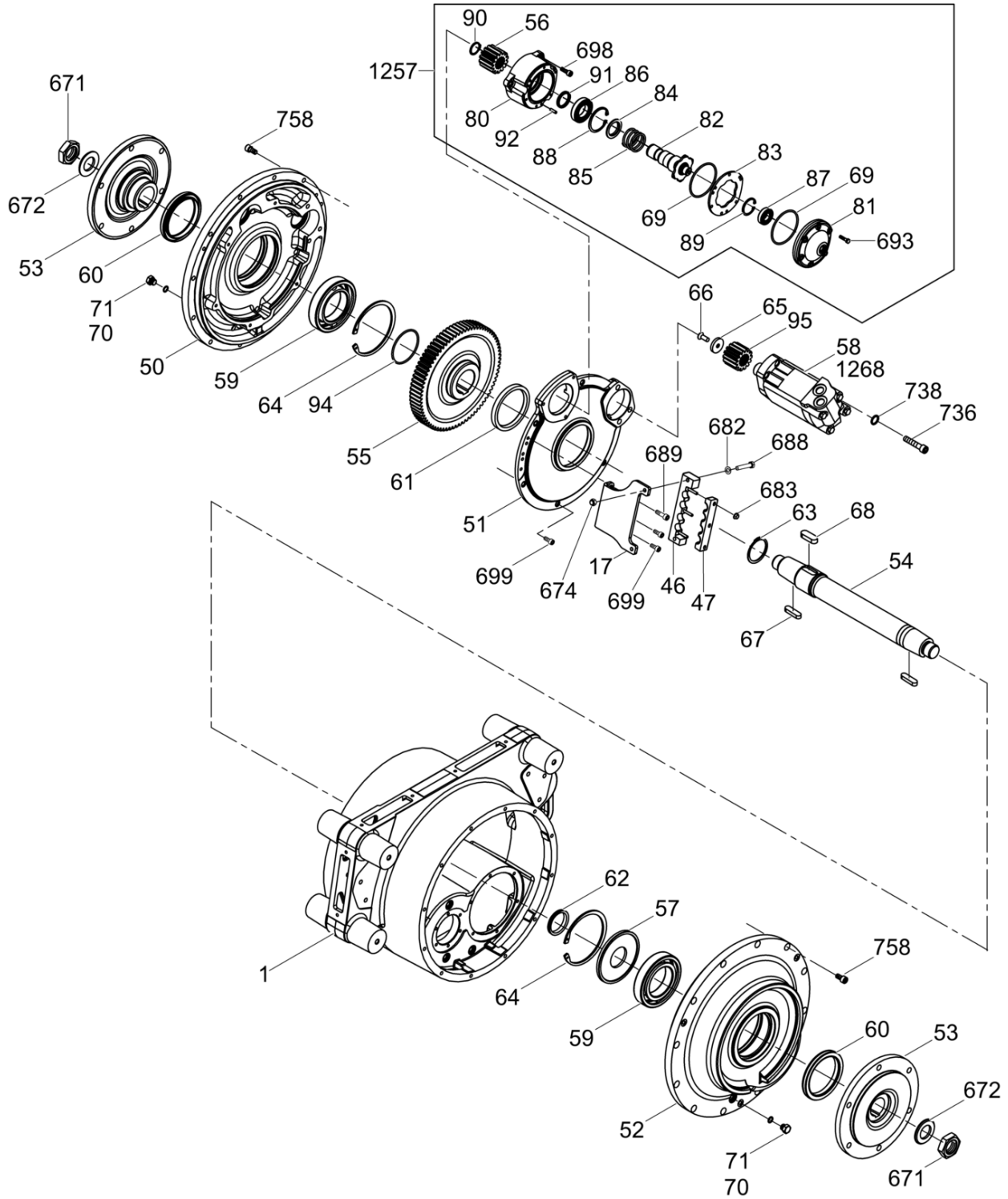

5100011103_02

Pos. Item	Artikel Nr. Item no.	Pc.	Unit	Beschreibung Descripción	Description Description	Abm. Dim.	Norm Standard
						Drehmoment Torque	Schmierstoff Lubricant
82	5000154320	1	pc	Welle Eje	Shaft Arbre		
83	5000117612	1	pc	Platte Placa	Plate Plaque		
84	5000151152	1	pc	Ring Anillo	Ring Anneau		
85	5000085783	1	pc	Feder Resorte	Spring Ressort		
86	5000027402	1	pc	Rillenkugellager Rodamiento de bolas	Grooved ball bearing Roulement à billes		
87	5002006236	1	pc	Rillenkugellager Rodamiento de bolas	Grooved ball bearing Roulement à billes		
88	5002001042	1	pc	Sicherungsring Anillo de retención	Retaining ring Bague d'arrêt	62 x 2	DIN472
89	5002004639	1	pc	Sicherungsring Anillo de retención	Retaining ring Bague d'arrêt	42 x 1,75	DIN472
90	5000152277	1	pc	Sicherungsring Anillo de retención	Retaining ring Bague d'arrêt	1,25 x 0,05	
91	5000089840	1	pc	Wellendichtring Sello del eje	Shaft seal Bague d'étanchéité		
92	5000054245	3	pc	Spannstift Pasador	Roll pin Goupille de tension	7/32 x 3/4 in	
93	5000119505	1	pc	Platte Placa	Plate Plaque		
94	5000152276	1	pc	O-Ring Anillo-o	O-ring Joint torique	81,92 x 5,33	
95	5000154482	1	pc	Ritzel Piñon diferencial	Pinion gear Pignon		
671	5000116871	2	pc	Mutter Tuerca	Nut Écrou	M36 x 3 825Nm/609ft.lbs	
672	5000150020	2	pc	Scheibe Arandela	Washer Rondelle	M36	
674	5000010367	2	pc	Sechskantmutter Tuerca hexagonal	Hexagon nut Écrou hexagonal	M8	DIN985
682	5000010622	2	pc	Scheibe Arandela	Flat washer Rondelle		
683	5000153379	3	pc	Dichtung Junta	Gasket Joint		
688	5000117969	2	pc	Sechskantschraube Tornillo hexagonal	Hexagonal head cap screw Boulon à tête hexagonale	M8 x 45 25Nm/18ft.lbs	
689	5000011541	1	pc	Zylinderschraube Tornillo cilíndrico	Cheese head screw Vis à tête cylindrique		
693	5000011469	6	pc	Sechskantschraube Tornillo hexagonal	Hexagonal head cap screw Vis à tête hexagonale	M6 x 25 10Nm/7ft.lbs	DIN933
698	5000011542	3	pc	Zylinderschraube Tornillo cilíndrico	Cheese head screw Vis à tête cylindrique	41Nm/30ft.lbs	
699	5000011543	6	pc	Zylinderschraube Tornillo hueco	Socket head screw Vis à six-pans creux	M8 x 20 25Nm/18ft.lbs	ISO4762
736	5100042214	3	pc	Zylinderschraube Tornillo cilíndrico	Socket head cap screw Vis à tête cylindrique	M12 x 60 106Nm/78ft.lbs	
738	5100055829	3	pc	Scheibe 13, FLACH, 300HV Arandela 13, plana, 300hv	Washer 13,flat,300hv Rondella 13, piatta, 300hv		
758	5000072758	30	pc	Zylinderschraube Tornillo cilíndrico	Cheese head screw Vis à tête cylindrique	M10 x 20 49Nm/36ft.lbs	ISO4762
1257	5000163621	1	pc	Bremse Kpl. Freno compl.	Brake cpl. Frein compl.		

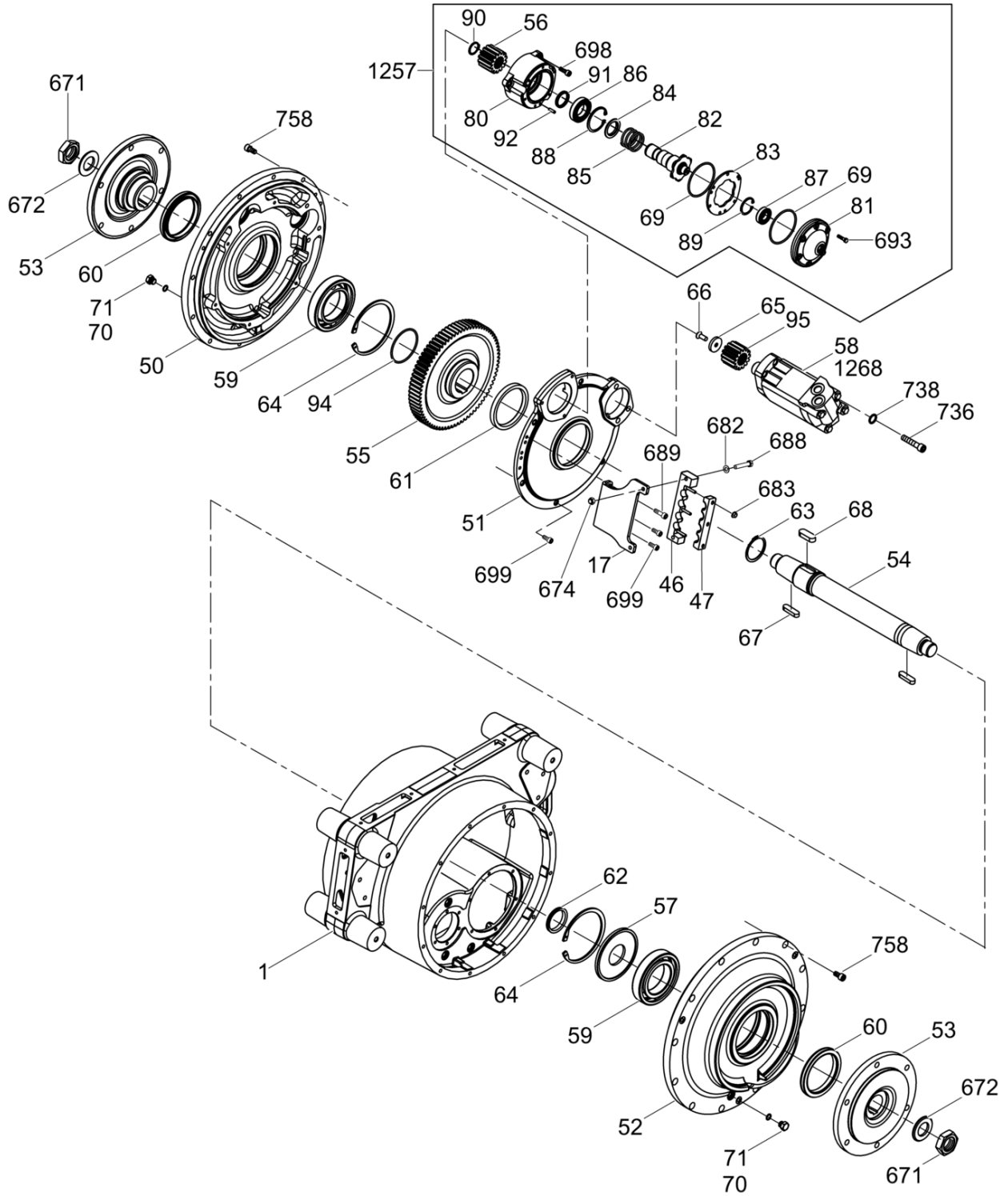

5100011103_02

Pos. Item	Artikel Nr. Item no.	Pc.	Unit	Beschreibung Descripción	Description Description	Abm. Dim.	Norm Standard
						Drehmoment Torque	Schmierstoff Lubricant
1268	5000182756	1	pc	Dichtungssatz Juego-empaque	Seal kit Jeu-joint		

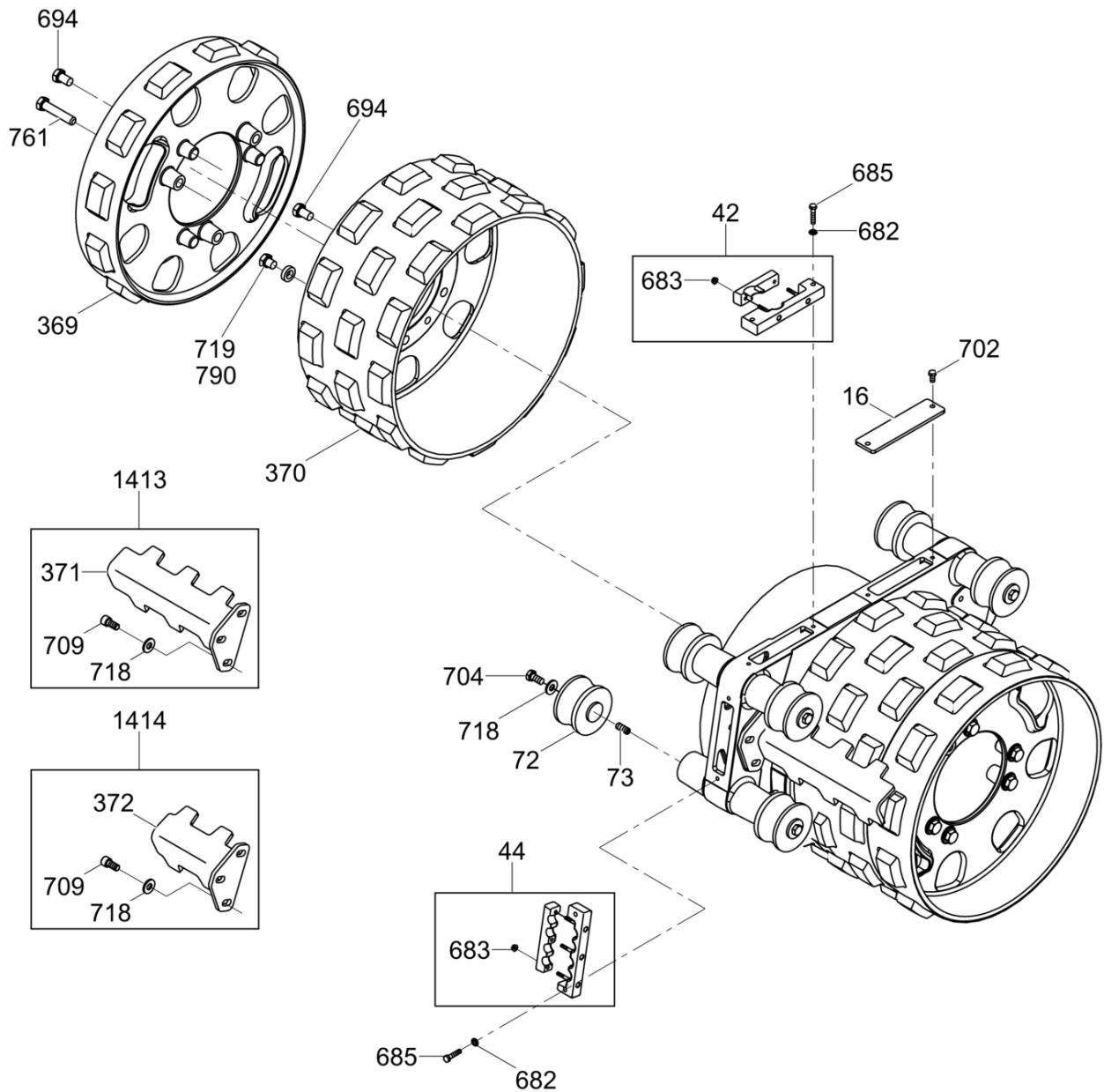

5200009646_01

Pos. Item	Artikel Nr. Item no.	Pc.	Unit	Beschreibung Descripción	Description Description	Abm. Dim.	Norm Standard
						Drehmoment Torque	Schmierstoff Lubricant
16	5000150306	1	pc	Platte Placa	Plate Plaque		
42	5200020383	1	pc	Schellensatz Juego de abrazaderas	Clamp set Jeu-agrafes		
44	5200020386	1	pc	Schellensatz Juego de abrazaderas	Clamp set Jeu-agrafes		
72	5002004814	6	pc	Gimetal-Kerblager Mit Bund Amortiguador	Shockmount Silentbloc	100 x 58	
73	5000180963	6	pc	Gewindestift Tornillo	Setscrew Vis	M12 x 35	
369	5200003694	4	pc	Bandageverlängerung Tambor de extensión	Drum extension Extension de tambour		
370	5200009074	2	pc	Bandage-Schmal Tambor-angosto	Narrow drum Tambour étroit		
371	5200007069	1	pc	Bandage-Abstreifer Barra raspadora-ancho	Wide scraper Racleur large		
372	5200007072	1	pc	Bandage-Schmal Barra raspadora-angosto	Narrow scraper Racleur étroit		
682	5000010622	4	pc	Scheibe Arandela	Flat washer Rondelle		
683	5000029117	5	pc	Sicherungsmutter Contratuercia	Lock nut Contre-écrou	M6	
685	5000011341	4	pc	Sechskantschraube Tornillo hexagonal	Hexagonal head cap screw Vis à tête hexagonale	M8 x 40 25Nm/18ft.lbs	DIN931
694	5000011524	12	pc	Sechskantschraube Tornillo hexagonal	Hexagonal head cap screw Vis à tête hexagonale	M16 x 25 211Nm/156ft.lbs	DIN933
702	5000012361	2	pc	Sechskantschraube Tornillo hexagonal	Hexagonal head cap screw Vis à tête hexagonale	M8 x 16 25Nm/18ft.lbs	DIN933
704	5000013002	6	pc	Sechskantschraube Tornillo hexagonal	Hexagonal head cap screw Vis à tête hexagonale	M12 x 25 86Nm/63ft.lbs	DIN933
709	5000017087	3	pc	Zylinderschraube Tornillo cilindrico	Socket head cap screw Vis à tête cylindrique	M12 x 30 86Nm/63ft.lbs	ISO4762
718	5000031565	10	pc	Spannscheibe Arandela elástica	Lockwasher Rondelle de ressort	12	DIN6796
719	5000031826	6	pc	Sechskantschraube Tornillo hexagonal	Hexagonal head cap screw Vis à tête hexagonale	M16 x 16 210Nm/155ft.lbs	
761	5000011380	12	pc	Sechskantschraube Tornillo hexagonal	Hexagonal head cap screw Boulon à tête hexagonale	M16 x 80 210Nm/155ft.lbs	DIN 931
790	5200009076	12	pc	Scheibe Arandela	Washer Rondelle	M16	
1413	5200007070	4	pc	Bandage-Abstreifer Kpl. Barra raspadora-ancho compl.	Wide scraper cpl. Racleur large compl.		
1414	5200007073	4	pc	Bandage-Schmal Kpl. Barra raspadora-angosto compl.	Narrow scraper cpl. Racleur étroit compl.		

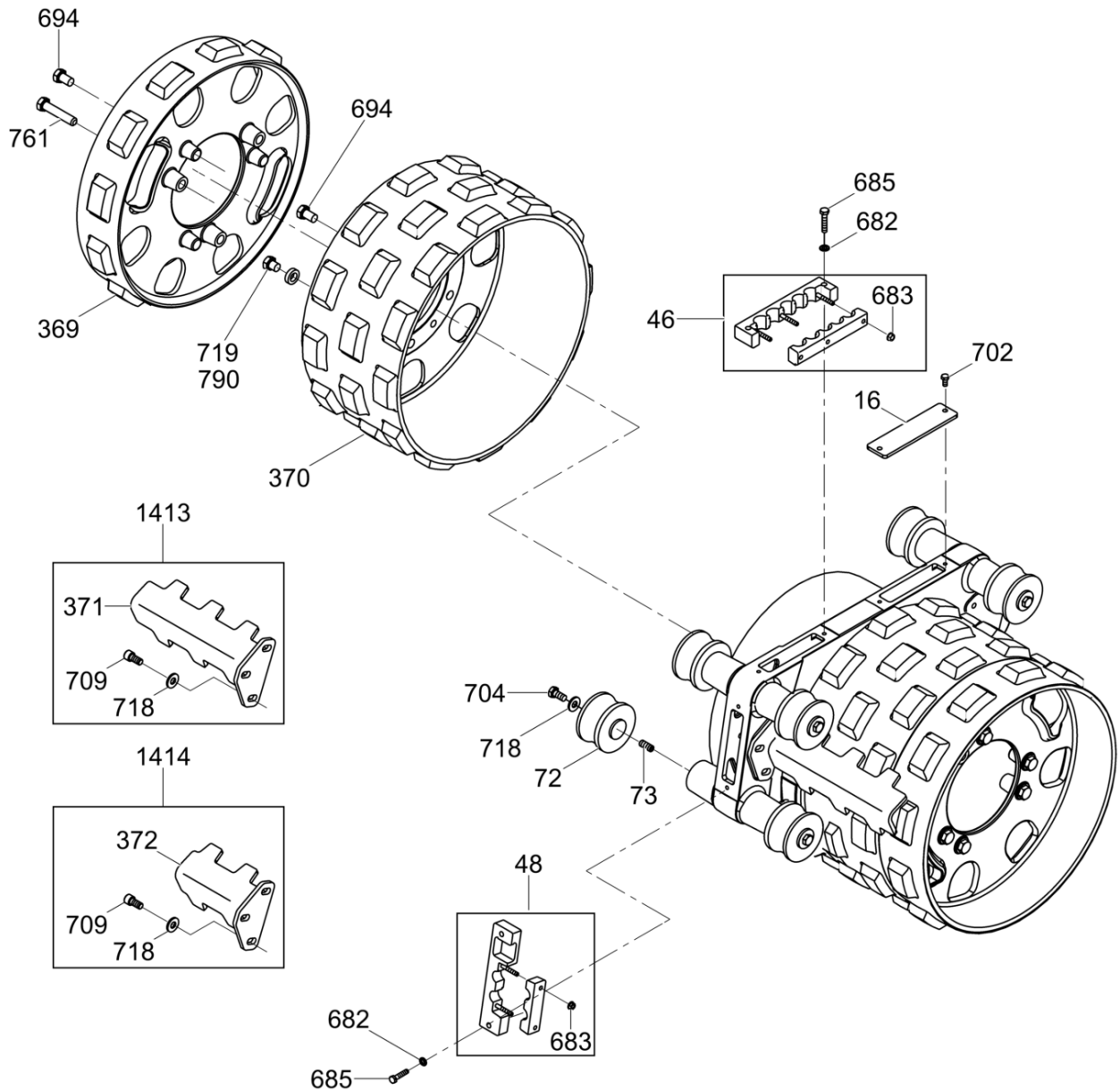

5200009647_03

Pos. Item	Artikel Nr. Item no.	Pc.	Unit	Beschreibung Descripción	Description Description	Abm. Dim.	Norm Standard
						Drehmoment Torque	Schmierstoff Lubricant
16	5000150306	1	pc	Platte Placa	Plate Plaque		
46	5200020388	1	pc	Schellensatz Juego de abrazaderas	Clamp set Jeu-agrafes		
48	5100036426	1	pc	Schellensatz Juego de abrazaderas	Clamp set Jeu-agrafes		
72	5002004814	6	pc	Gimetal-Kerblager Mit Bund Amortiguador	Shockmount Silentbloc	100 x 58	
73	5000180963	6	pc	Gewindestift Tornillo	Setscrew Vis	M12 x 35	
369	5200003694	2	pc	Bandageverlängerung Tambor de extensión	Drum extension Extension de tambour		
370	5200009074	2	pc	Bandage-Schmal Tambor-angosto	Narrow drum Tambour étroit		
371	5200007069	1	pc	Bandage-Abstreifer Barra raspadora-ancho	Wide scraper Racleur large		
372	5200007072	1	pc	Bandage-Schmal Barra raspadora-angosto	Narrow scraper Racleur étroit		
678	5000010624	2	pc	Scheibe Arandela	Flat washer Rondelle		
682	5000010622	5	pc	Scheibe Arandela	Flat washer Rondelle		
685	5000011341	4	pc	Sechskantschraube Tornillo hexagonal	Hexagonal head cap screw Vis à tête hexagonale	M8 x 40 25Nm/18ft.lbs	DIN931
694	5000011524	12	pc	Sechskantschraube Tornillo hexagonal	Hexagonal head cap screw Vis à tête hexagonale	M16 x 25 210Nm/155ft.lbs	DIN933
702	5000012361	2	pc	Sechskantschraube Tornillo hexagonal	Hexagonal head cap screw Vis à tête hexagonale	M8 x 16 25Nm/18ft.lbs	DIN933
704	5000013002	6	pc	Sechskantschraube Tornillo hexagonal	Hexagonal head cap screw Vis à tête hexagonale	M12 x 25 86Nm/63ft.lbs	DIN933
709	5000017087	3	pc	Zylinderschraube Tornillo cilindrico	Socket head cap screw Vis à tête cylindrique	M12 x 30 86Nm/63ft.lbs	ISO4762
718	5000031565	10	pc	Spannscheibe Arandela elástica	Lockwasher Rondelle de ressort	12	DIN6796
719	5000031826	6	pc	Sechskantschraube Tornillo hexagonal	Hexagonal head cap screw Vis à tête hexagonale	M16 x 16 210Nm/155ft.lbs	
759	5000011380	6	pc	Sechskantschraube Tornillo hexagonal	Hexagonal head cap screw Boulon à tête hexagonale	M16 x 80 210Nm/155ft.lbs	DIN 931
779	5000011456	2	pc	Sechskantschraube Tornillo hexagonal	Hexagonal head cap screw Vis à tête hexagonale		
790	5200009076	12	pc	Scheibe Arandela	Washer Rondelle	M16	
1413	5200007070	4	pc	Bandage-Abstreifer Kpl. Barra raspadora-ancho compl.	Wide scraper cpl. Racleur large compl.		
1414	5200007073	4	pc	Bandage-Schmal Kpl. Barra raspadora-angosto compl.	Narrow scraper cpl. Racleur étroit compl		

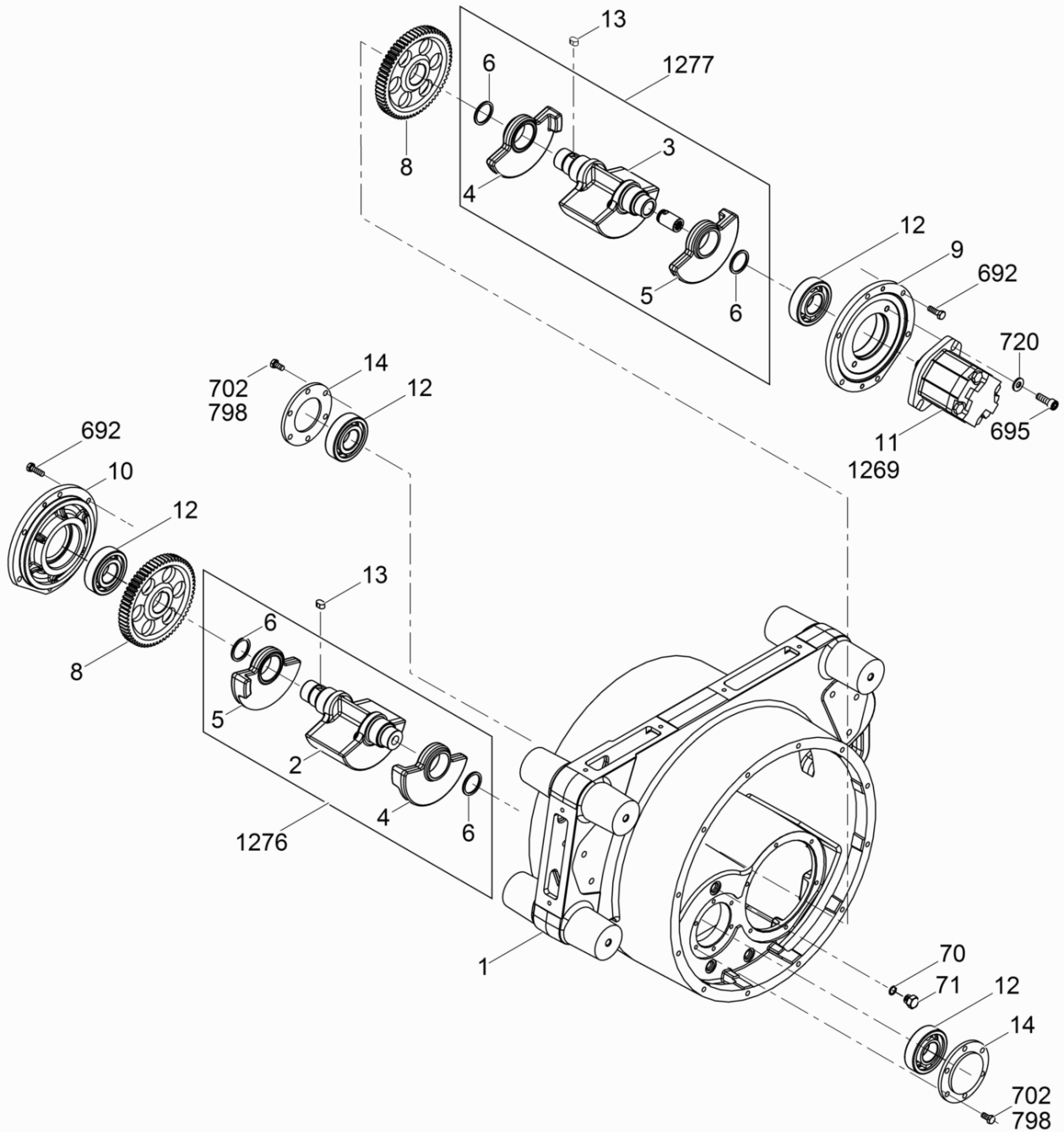

200_5000620293232014

Pos. Item	Artikel Nr. Item no.	Pc.	Unit	Beschreibung Descripción	Description Description	Abm. Dim.	Norm Standard
						Drehmoment Torque	Schmierstoff Lubricant
1	5000116902	1	pc	Bandagenträger Soporte del tambor	Drum support Support de tambour		
2	5000171032	2	pc	Erregerwelle Ohne Senkung Eje del excitador s/escariador	Exciter shaft w/o counterbore Arbre de l'excitatrice sans lo		
3	5000171033	2	pc	Erregerwelle Mit Senkung Eje del excitador c/escariador	Exciter shaft w/counterbore Arbre de l'excitatrice avec lo		
4	5000171034	4	pc	Unwucht Masa excéntrica	Eccentric weight Balourd excentrique		
5	5000171035	4	pc	Unwucht Masa excéntrica	Eccentric weight Balourd excentrique		
6	5000171028	8	pc	Sicherungsring Anillo de retención	Retaining ring Bague d'arrêt	45 x 1,69in	
8	5200001515	2	pc	Zahnrad Engranaje	Gear Engrenage		
9	5000116958	1	pc	Deckel Tapa	Cover Couvercle		
10	5000116959	1	pc	Lagerdeckel Tapa del rodamiento	Bearing cover Tapa del rodamiento		
11	5000182917	1	pc	Erregermotor Motor excitador	Exciter motor Moteur d'excitatrice		
12	5000080742	4	pc	Rollenlager Rodamiento de rodillos	Roller bearing Roulement à rouleaux		
13	5000115699	2	pc	Passfeder Chaveta	Square key Clavette	A10 x 8 x 16	DIN6885
14	5000171000	4	pc	Deckel Tapa	Cover Couvercle		
70	5000014398	3	pc	O-Ring Anillo-o	O-ring Joint torique	12 x 2	
71	5000078269	3	pc	Schraubverschluß Tapón roscado	Plug (threaded) Bouchon	9/16-18in	
692	5000011457	12	pc	Sechskantschraube Tornillo hexagonal	Hexagonal head cap screw Vis à tête hexagonale	M8 x 25 25Nm/18ft.lbs	
695	5000011534	2	pc	Zylinderschraube Tornillo cilíndrico	Cheese head screw Vis à tête cylindrique	M10 x 30 49Nm/36ft.lbs	ISO4762
702	5000012361	12	pc	Sechskantschraube Tornillo hexagonal	Hexagonal head cap screw Vis à tête hexagonale	M8 x 16 25Nm/18ft.lbs	DIN933
720	5000033988	2	pc	Spannscheibe Arandela elástica	Lockwasher Rondelle de ressort	10	DIN6796
798	5000172326	24	pc	Scheibe Arandela elástica	Flat washer Rondelle de ressort	8.4	
1269	5200024514	1	pc	Dichtungssatz Juego-empaque	Seal kit Jeu-joint		
1276	5000171445	2	pc	Erregerwellensatz Ohne Senkung Juego-eje del excitador s/ escariador	Exciter shaft kit w/o counterbore Jeu-arbre de l'excitatrice san		
1277	5000171446	2	pc	Erregerwellensatz Mit Senkung Juego-eje del excitador c/ escariador	Exciter shaft kit w/counterbore Jeu-arbre de l'excitatrice ave		

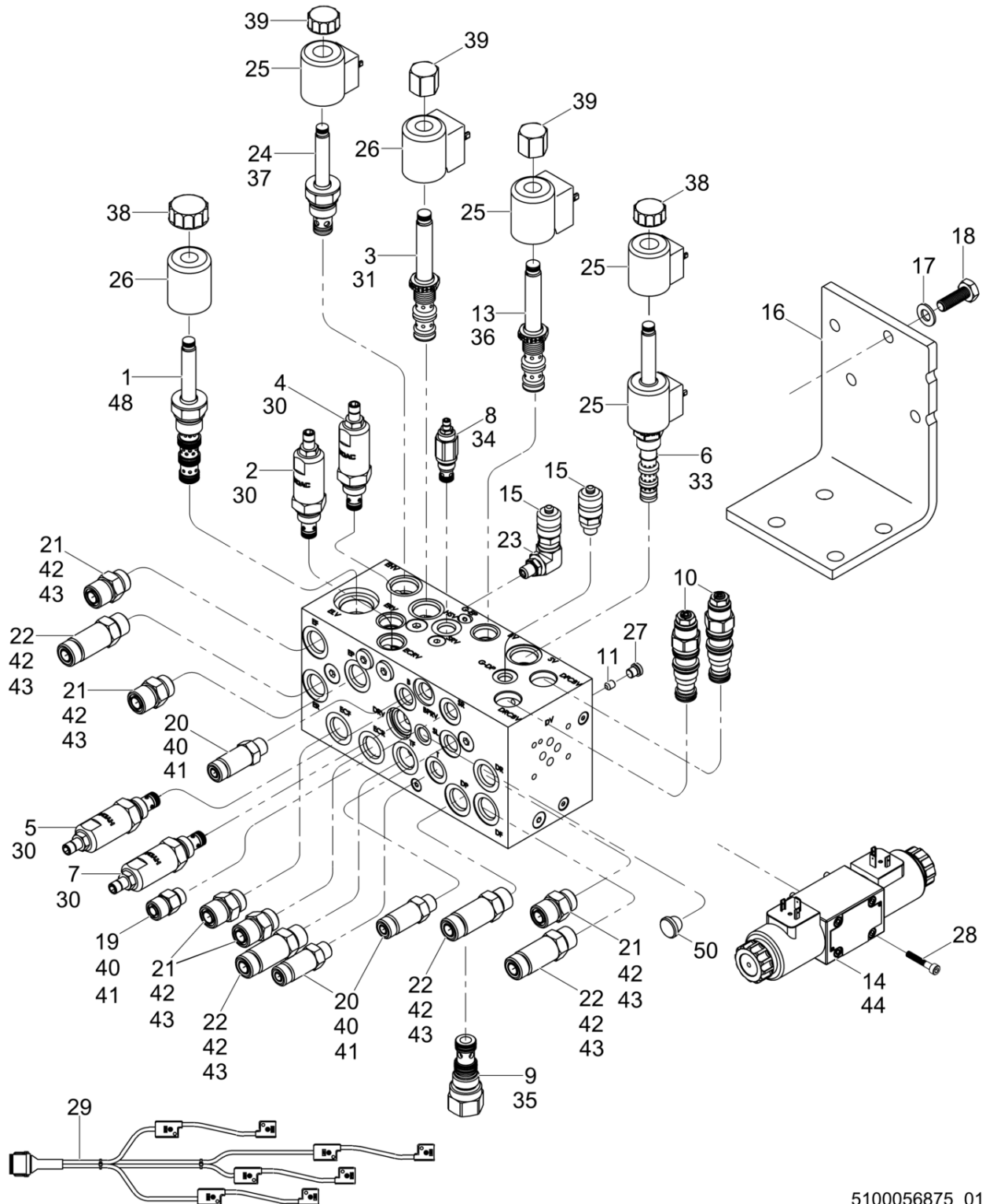

5100056875_01

Pos. Item	Artikel Nr. Item no.	Pc.	Unit	Beschreibung Descripción	Description Description	Abm. Dim.	Norm Standard
						Drehmoment Torque	Schmierstoff Lubricant
1	5100016775	1	pc	Ventil-Solenoid Válvula-solenoide	Solenoid valve Électrovanne		
2	5100016776	1	pc	Überdruckventil Válvula de desahoga	Relief valve Soupape de surpression		
3	5100016777	1	pc	Ventil-Solenoid Válvula-solenoide	Solenoid valve Électrovanne		
4	5100016778	1	pc	Überdruckventil Válvula de desahoga	Relief valve Soupape de surpression		
5	5100050074	1	pc	Überdruckventil Válvula de desahoga	Relief valve Soupape de surpression		
6	5100016780	1	pc	Steuerventil Válvula de dirección	Steering valve Soupape de direction		
7	5100016781	1	pc	Überdruckventil Válvula de desahoga	Relief valve Soupape de surpression		
8	5100016782	1	pc	Steuerventil Válvula de dirección	Steering valve Soupape de direction		
9	5100016783	1	pc	Bypassventil Válvula de desviador	Bypass valve Soupape de dérivation		
10	5100016784	2	pc	Ausgleichsventil Válvula de compensación	Counterbalance valve Soupape de contrecharge		
11	5100016785	1	pc	Gewindestift Tornillo	Setscrew Vis	2,70	
12	5100016786	1	pc	Gewindestift Tornillo	Setscrew Vis	0,80	
13	5100016787	1	pc	Bremsventil Válvula de frenaje	Brake valve Robinet de freinage		
14	5100046563	1	pc	Antriebsventil Válvula de mando	Drive valve Soupape d'entraînement		
15	5000182738	2	pc	Prüfverschraubung Mit Kappe Unión de prueba con tapa	Test fitting w/cap Raccord d'essai avec couvercle	M16 x 2, 7/16-20 UNC	
16	5100016789	1	pc	Konsole Ménsula	Mounting bracket Support		
17	5000010621	3	pc	Scheibe Arandela	Flat washer Rondelle		
18	5200015174	4	pc	Sechskantschraube Tornillo hexagonal	Hexagonal head cap screw Vis à tête hexagonale		
19	5000078816	1	pc	Zwischenverschraubung Unión con adaptador	Adapter fitting Raccord intermédiaire		
20	5000158574	3	pc	Verschraubung Unión	Fitting Raccord	No.6	
21	5000080558	6	pc	Verschraubung Unión	Fitting Raccord		
22	5000158572	3	pc	Verschraubung Unión	Fitting Raccord	No.8	
23	5100016790	1	pc	Hydraulikverschraubung Unión hidráulico	Hydraulic fitting Raccord hydraulique	4 x 4	
24	5100016791	1	pc	Erregung Des Ventils Excitador de válvula	Exciter valve Excitation de valve		
25	5100016792	4	pc	Spule Bobina	Coil Bobine	12V	
26	5100016793	2	pc	Spule Bobina	Coil Bobine	12V	
27	5100016794	9	pc	Stopfen Tapón	Plug Bouchon	No. 2	
28	5000011558	4	pc	Zylinderschraube Tornillo cilíndrico	Cheese head screw Vis à tête cylindrique	M5 x 30 10Nm/7ft.lbs	ISO4762

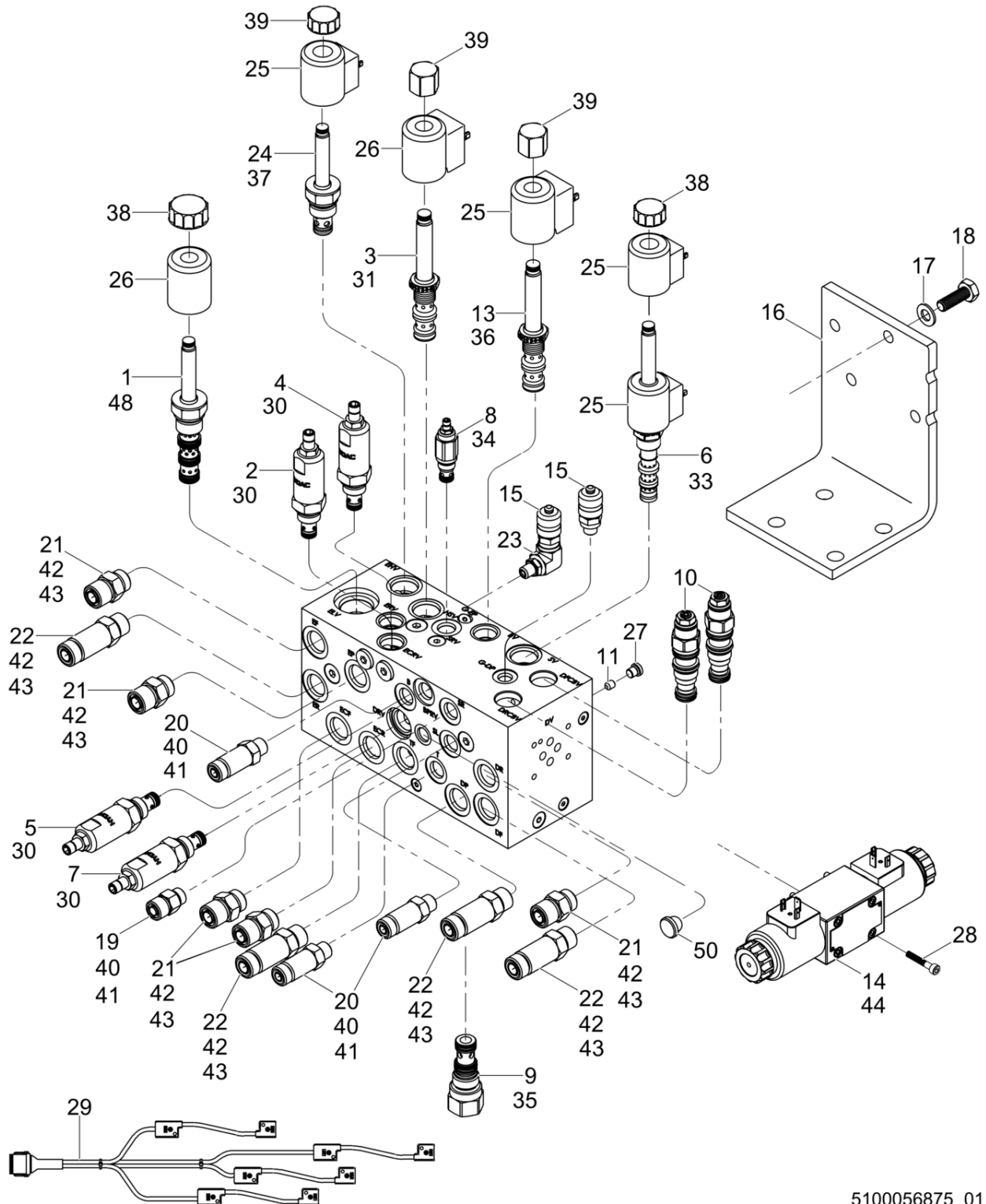

5100056875_01

Pos. Item	Artikel Nr. Item no.	Pc.	Unit	Beschreibung Descripción	Description Description	Abm. Dim.	Norm Standard
						Drehmoment Torque	Schmierstoff Lubricant
29	5100050073	1	pc	Kabelbaum Conjunto de cables	Wiring harness Harnais de câbles électriques		
30	5100016796	3	pc	Dichtungssatz Juego-empaque	Seal kit Jeu-joint		
31	5100016797	1	pc	Dichtungssatz Juego-empaque	Seal kit Jeu-joint		
32	5100016798	1	pc	Dichtungssatz Juego-empaque	Seal kit Jeu-joint		
33	5100016799	1	pc	Dichtungssatz Juego-empaque	Seal kit Jeu-joint		
34	5100016800	1	pc	Dichtungssatz Juego-empaque	Seal kit Jeu-joint		
35	5100016801	1	pc	Dichtungssatz Juego-empaque	Seal kit Jeu-joint		
36	5100016802	1	pc	Dichtungssatz Juego-empaque	Seal kit Jeu-joint		
37	5100016803	1	pc	Dichtungssatz Juego-empaque	Seal kit Jeu-joint		
38	5100016804	2	pc	Spule Kpl. Bobina compl.	Coil kit Bobine compl.		
39	5100016805	3	pc	Ventilkappe Bobina compl.	Coil kit Bobine compl.		
40	5000080731	4	pc	O-Ring Anillo-o	O-ring Joint torique	0,47 x 0,07in #6	
41	5000080736	4	pc	O-Ring Anillo-o	O-ring Joint torique	0,36 x 0,07in #6 ORFS	
42	5000080732	9	pc	O-Ring Anillo-o	O-ring Joint torique	0,64 x 0,09in #8	
43	5000080737	9	pc	O-Ring Anillo-o	O-ring Joint torique	0,49 x 0,07in #8 ORFS	
44	5100016873	1	pc	Dichtungssatz Juego-empaque	Seal kit Jeu-joint		
48	5100016795	1	pc	Dichtungssatz Juego-empaque	Seal kit Jeu-joint		
50	5100056876	1	pc	Sieb Tamizador	Strainer Tamis		

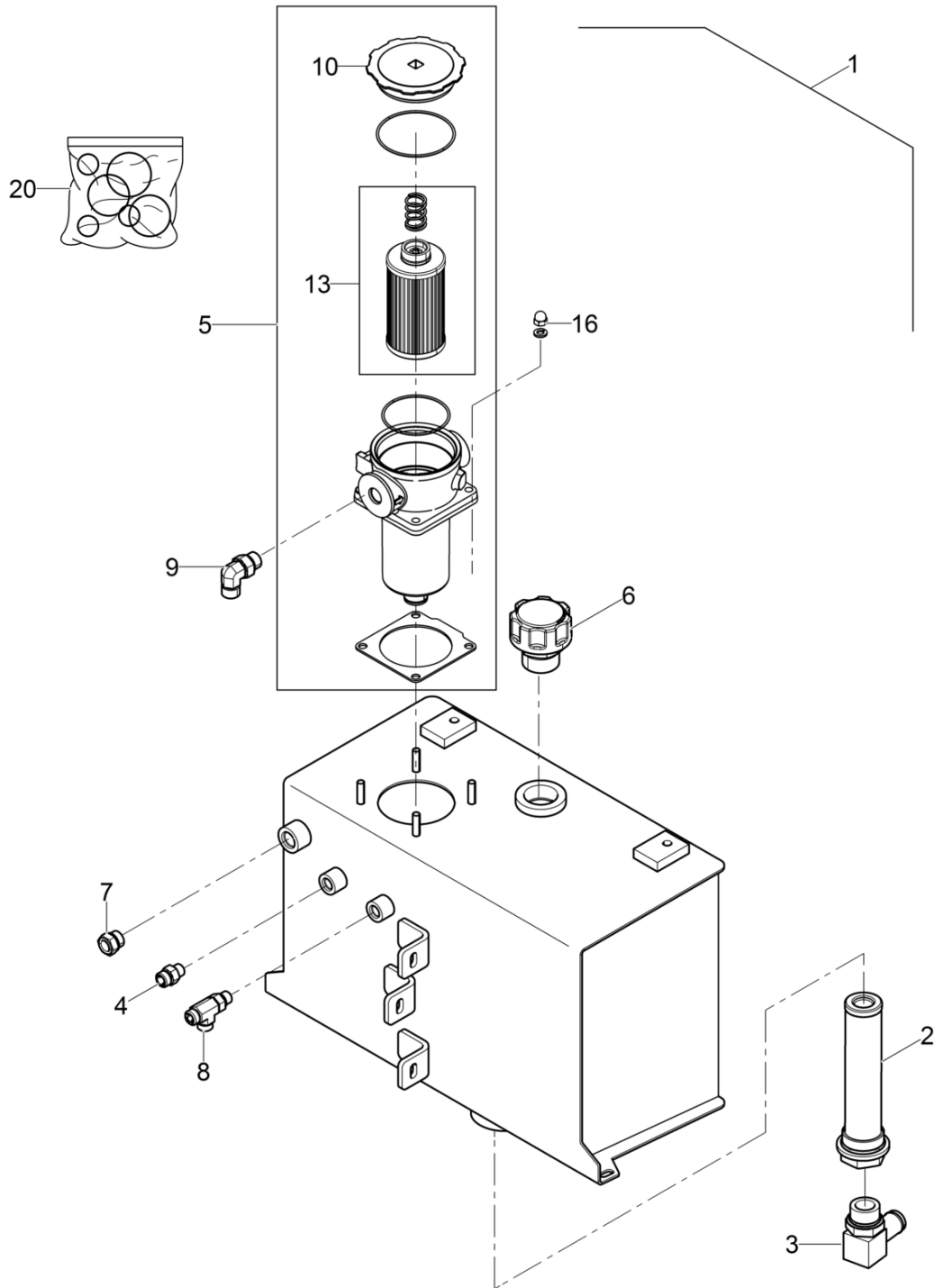

wc_ex0179971001

Pos. Item	Artikel Nr. Item no.	Pc.	Unit	Beschreibung Descripción	Description Description	Abm. Dim.	Norm Standard
						Drehmoment Torque	Schmierstoff Lubricant
1	5200000844	1	pc	Hydrauliktank Tanque hidráulico	Hydraulic tank Réservoir hydraulique		
2	5000182746	1	pc	Saugkorb Colador	Suction strainer Crépine		
3	5000182747	1	pc	Verschraubung Mit Widerhaken Unión dentada	Barbed fitting Raccord à picot	No.6 x 90	
4	5000078816	1	pc	Zwischenverschraubung Unión con adaptador	Adapter fitting Raccord intermédiaire		
5	5000182748	1	pc	Rückleitungsfilter Filtro de retorno	Return filter Filtre de retour		
6	5200000845	1	pc	Entlüftungskappe Tapa respiradero	Breather tube Capuchon reniflard		
7	5000116236	1	pc	Ölschauglas Mirilla del nivel de aceite	Sightglass Verre-regard d'huile		
8	5000083412	1	pc	Verschraubung Unión	Fitting Raccord		
9	5000111272	1	pc	Hydraulikrohrkrümmer Codo hidráulico	Hydraulic elbow fitting Coude hydraulique	SAE No.8 x 90	
10	5000182750	1	pc	Deckel Tapa	Cover Couvercle		
13	5000182752	1	pc	Filterelement Elemento del filtro	Filter element Élément du filtre		
16	5000159508	4	pc	Hutmutter Tuerca	Acorn nut Ecrou	M10	
20	5000182733	1	pc	Dichtungs- U. O-Ringsatz Juego de juntas/anillos-o	Gasket & o-ring set Jeu de joints		

Sender
 Transmitter module
 Transmisor
 Transmetteur

RTLX-SC3

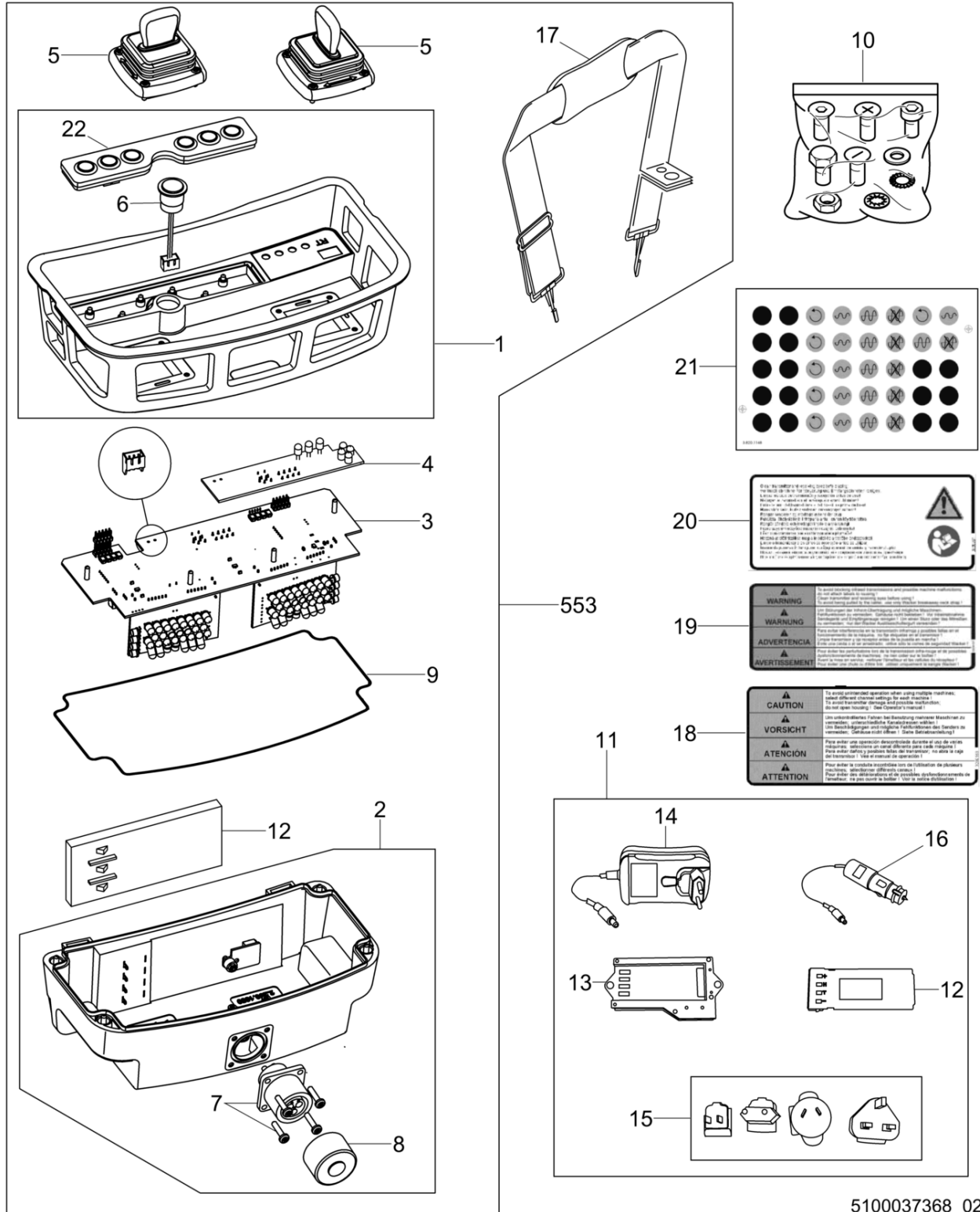

5100037368_02

Pos. Item	Artikel Nr. Item no.	Pc.	Unit	Beschreibung Descripción	Description Description	Abm. Dim.	Norm Standard
						Drehmoment Torque	Schmierstoff Lubricant
1	5100029414	1	pc	Oberer Rahmen Chasis superior	Upper housing Châssis supérieur		
2	5000180315	1	pc	Untere Umhüllung Envoltura inferior	Lower housing Gaine inférieure		
3	5100044531	1	pc	Schaltplatte Tablero de circuitos	Circuit board Carte de circuit		
4	5000180317	1	pc	Leiterplatte Presentación de tablero de circuitos	Circuit board display Affichage de carte de circuit		
5	5000177083	2	pc	Steuerhebel-Satz Palanca de dirección-juego	Steering lever kit Lever de direction-jeu		
6	5100044532	1	pc	Schalter, Ein/Aus Interruptor, enc./apag.	On/off switch Interrupteur, marche/arrêt		
7	5100037365	1	pc	3-Polige Buchse Socket 3-pin	3-pin connector 3 broches		
8	5000117184	1	pc	Kappe Tapa	Cap Couvercle		
9	5000164704	1	pc	Dichtung Empaque	Seal Joint		
10	5000180320	1	pc	Kleinteilesatz Juego de piezas pequeñas	Hardware kit Jeu de pièces		
11	5000213091	1	pc	Ladegerät Juego de carga	Charging set Jeu de charge		
12	5000210156	1	pc	Akku Batería	Battery Accumalteur		
13	5000209760	1	pc	Ladegerät Cargador par batería	Battery charger Chargeur de batteries		
14	5000209761	1	pc	Steckernetzteil Enchufe de alimentación	Electrical plug Mains plug		
15	5000209762	1	pc	Steckeradapter-Set Enchufe de alimentación	Plug adapter set Mains plug		
16	5000209763	1	pc	Anschlusskabel Cable de alimentación	Power cable Cable d'alimentation		
17	5000114783	1	pc	Band Cinta	Band Ruban		
18	5000209158	1	pc	Aufkleber-Hinweis Calcomanía-indicación	Instruction label Autocollant avec indication		
19	5000209157	1	pc	Aufkleber-Warnung Calcomanía-advertencia	Label-warning Autocollant-avertissement		
20	5000226261	1	pc	Aufkleber Calcomanía	Label Autocollant		
21	5200017125	1	pc	Aufkleberblatt Hoja de calcomanías	Label sheet Feuille d'autocollants		
22	5100037750	1	pc	Plattenmodul Anschließen Módulo de placa de interruptor	Switch plate module Module de plaque d'interrupteu		
553	5000165514	1	pc	Sender Transmisor	Transmitter module Transmetteur		

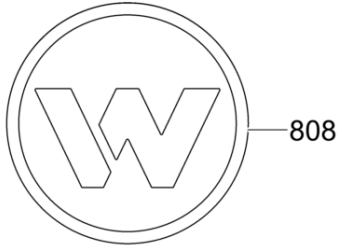

808

CHANGIL LABELA	1	1	9	9
BAKIN THE OPERATOR'S MANUAL, ON BOTH TRANSMITTER AND RECEIVER, REPLACE ORIGINAL LABELS WITH NEW WHEN CHANNELS ARE CHANGED.	2	2	0	0
EXAMINAR LIBRO DE INSTRUCCIONES DEL OPERADOR, EN EL TRANSMISOR Y EN EL RECEPTOR, SUSTITUIR LAS ETIQUETAS ORIGINALES POR LAS NUEVAS CUANDO SE CAMBIEN LOS CANALES.	3	3	A	A
EXAMINER LE MANUEL D'INSTRUCTIONS, A LA VOIE DU TRANSMETTEUR ET A LA VOIE DU RECEPTEUR, REMPLACER LES ETIQUETTES ORIGINALES PAR LES NOUVELLES QUAND LES CANAUX SONT CHANGES.	4	4	B	B
EXAMINAR O MANUAL DO OPERADOR, NO TANT O TRANSMISSOR COMO O RECEPTOR, SUSTITUIR O ETIQUETAS ORIGINAIS POR O NOVAS QUANDO O CANAL FORNO MUDADO.	5	5	C	C
EXAMINAR O MANUAL DO OPERADOR, NO TANT O TRANSMISSOR COMO O RECEPTOR, SUSTITUIR O ETIQUETAS ORIGINAIS POR O NOVAS QUANDO O CANAL FORNO MUDADO.	6	6	D	D
EXAMINER LE MANUEL D'INSTRUCTIONS, A LA VOIE DU TRANSMETTEUR ET A LA VOIE DU RECEPTEUR, REMPLACER LES ETIQUETTES ORIGINALES PAR LES NOUVELLES QUAND LES CANAUX SONT CHANGES.	7	7	E	E
EXAMINER LE MANUEL D'INSTRUCTIONS, A LA VOIE DU TRANSMETTEUR ET A LA VOIE DU RECEPTEUR, REMPLACER LES ETIQUETTES ORIGINALES PAR LES NOUVELLES QUAND LES CANAUX SONT CHANGES.	8	8	F	F

807

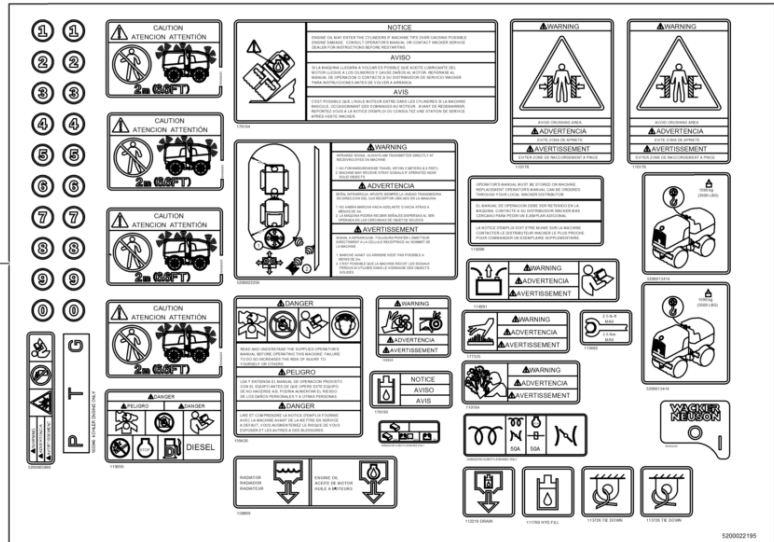

805

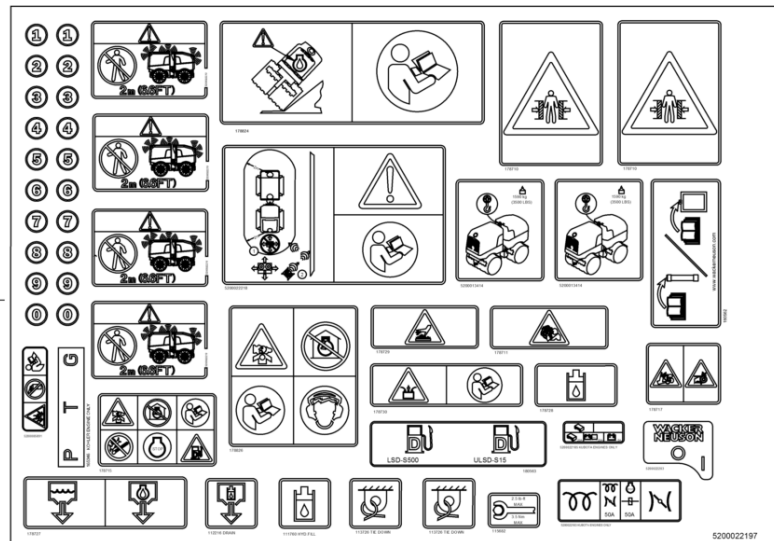

1301

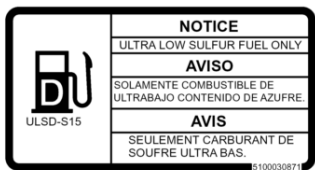

816

801—RTSC3

802—WACKER
NEUSON

5200022894_02



Pos. Item	Artikel Nr. Item no.	Pc.	Unit	Beschreibung Descripción	Description Description	Abm. Dim.	Norm Standard
						Drehmoment Torque	Schmierstoff Lubricant
801	5200023102	2	pc	Aufkleber Calcomania	Label Autocollant		
802	5000222136	2	pc	Aufkleber, Logo Calcomanía-logotipo	Label-logo Autocollant - logo	100 OD	
805	5200022195	1	pc	Aufkleberblatt Hoja de calcomanias	Label sheet Feuille d'autocollants		
807	5000171055	1	pc	Aufkleber Calcomania	Label Autocollant		
808	5000222087	2	pc	Aufkleber Symbol Calcomania símbololo	Label symbol Autocollant symbole	120 OD	
816	5100030871	1	pc	Aufkleber Calcomania	Label-diesel fuel Autocollant		
1301	5200022197	1	pc	Aufkleberblatt-EU Hoja de calcomanias-eu	Label sheet-eu Feuille d'autocollants-eu		

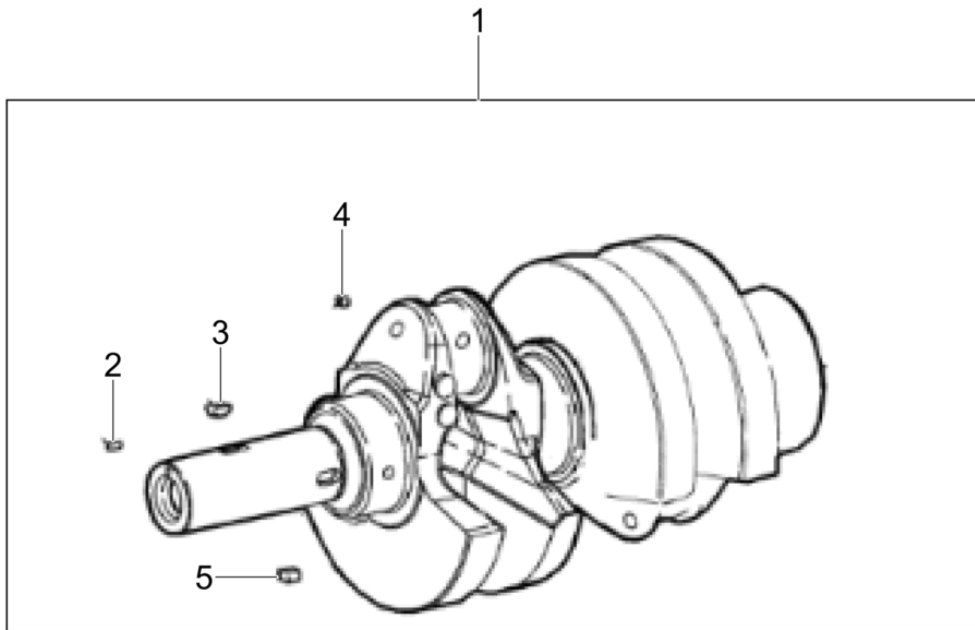

5100042139_01

Pos. Item	Artikel Nr. Item no.	Pc.	Unit	Beschreibung Descripción	Description Description	Abm. Dim.	Norm Standard
						Drehmoment Torque	Schmierstoff Lubricant
1	5000160365	1	pc	Kurbelwelle Cigueñal	Crankshaft Vilebrequin		
2	5000159357	1	pc	Stift Espiga	Pin Goupille		
3	5000159260	1	pc	Woodruffkeil Chaveta woodruff	Woodruff key Clavette woodruff		
4	5000159454	3	pc	Schraubverschluß Tapón roscado	Plug (threaded) Bouchon		
5	5000159261	1	pc	Passfeder Chaveta	Square key Clavette		

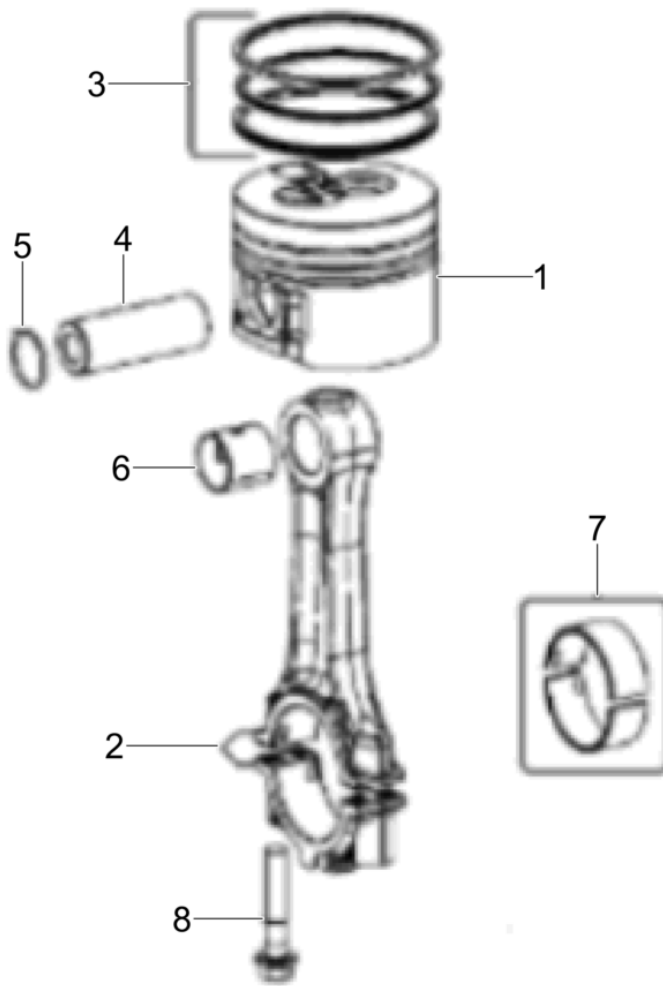

5100042340_01

Pos. Item	Artikel Nr. Item no.	Pc.	Unit	Beschreibung Descripción	Description Description	Abm. Dim.	Norm Standard
						Drehmoment Torque	Schmierstoff Lubricant
1	5000160377	3	pc	Kolbensatz Juego de pistón	Set of piston Jeu de piston		
1	5000160375	3	pc	Kolbensatz Juego de pistón	Set of piston Jeu de piston		
1	5000160376	3	pc	Kolbensatz Juego de pistón	Set of piston Jeu de piston		
2	5200009449	3	pc	Pleuel Biela	Connecting rod Bielle		
3	5000160383	2	pc	Kolbenringsatz Juego de cubo levantador	Piston ring set Jeu de moyeu de levage		
3	5000160384	2	pc	Ringsatz Juego de cubo levantador	Piston ring set Jeu de moyeu de levage		
3	5000160385	2	pc	Ringsatz Juego de cubo levantador	Piston ring set Jeu de moyeu de levage		
4	5000215523	3	pc	Kolbenbolzen Perno de pistón	Piston pin Axe de piston		
5	5000215477	6	pc	Sicherungsring Anillo de retención	Retaining ring Bague d'arrêt		
6	5200009452	2	pc	Buchse Buje	Bushing Douille		
7	5000155691	2	pc	Pleuellagerangen Rodamiento	Bearing Roulement		
7	5000155689	2	pc	Lagerschalen Rodamiento	Bearing Roulement		
7	5000155690	2	pc	Pleuellagerangen Rodamiento	Bearing Roulement		
8	5000084175	4	pc	Schraube Tornillo	Screw Vis		

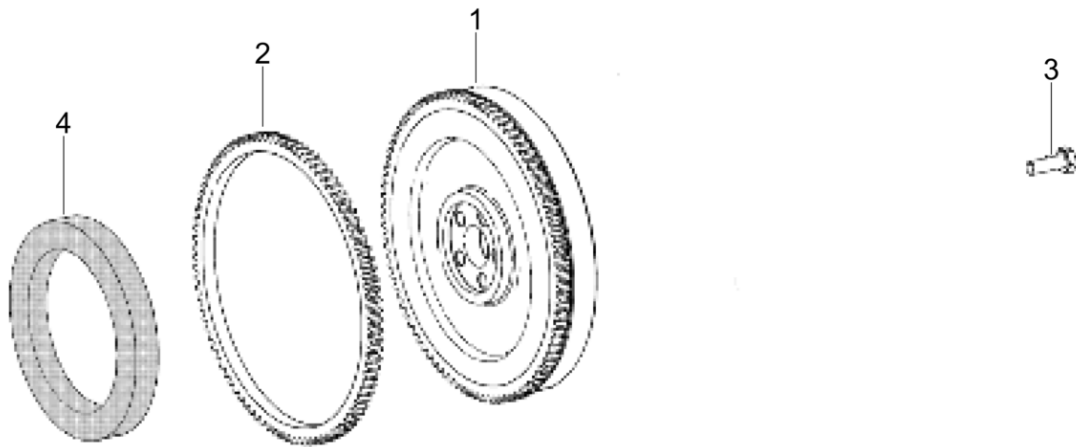

5100042341_01

Pos. Item	Artikel Nr. Item no.	Pc.	Unit	Beschreibung Descripción	Description Description	Abm. Dim.	Norm Standard
						Drehmoment Torque	Schmierstoff Lubricant
1	5000159485	1	pc	Schwungrad Kpl. Volante compl.	Flywheel compl. Volant compl.		
2	5000155693	1	pc	Zahnkranz Borde de engranaje	Gear crown Jante d'engrenage		
3	5000160188	5	pc	Bolzen Perno	Bolt Boulon		
4	5000159258	1	pc	Rotor Rotor	Rotor Rotor		

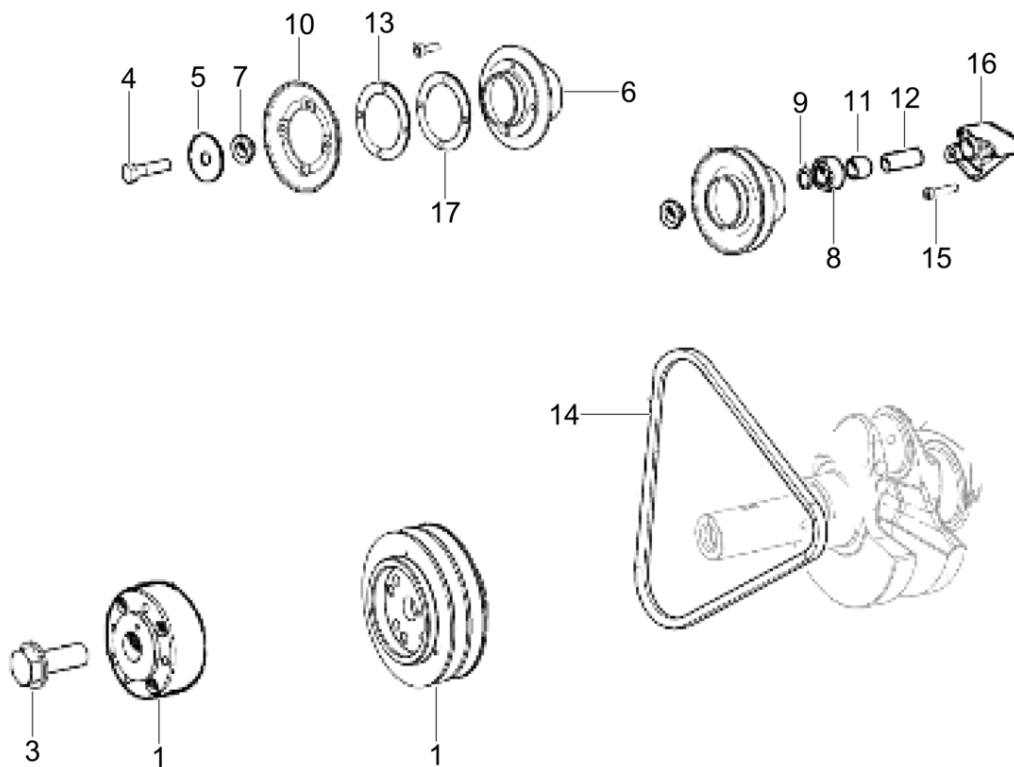

5100042342_01

Pos. Item	Artikel Nr. Item no.	Pc.	Unit	Beschreibung Descripción	Description Description	Abm. Dim.	Norm Standard
						Drehmoment Torque	Schmierstoff Lubricant
1	5000155723	1	pc	Scheibe Disco	Crankshaft pulley Rondelle		
2	5000159475	4	pc	Schraube Tornillo	Screw Vis		
3	5000126935	1	pc	Bolzen Perno	Bolt Boulon		
4	5000159490	1	pc	Bolzen Perno	Bolt Boulon	M8x1.25x90	
5	5000159346	1	pc	Scheibe Disco	Washer Rondelle		
6	5000159345	1	pc	Konsole Kpl. Consola cpl.	Pulley cpl. Console cpl.		
6	5200023964	1	pc	Scheibe Polea	Pulley Poulie		
7	5000159347	1	pc	Scheibe Disco	Washer Rondelle		
8	5000082135	2	pc	Lager Cojinete	Bearing Palier		
9	5000159241	2	pc	Sicherungsring Anillo de retención	Retaining ring Bague d'arrêt		
10	5000207987	1	pc	Riemenscheibenhälfte Semi polea en v	V-belt pulley half Flanc de poulie à courroie		
11	5000159277	1	pc	Abstandsstück Espaciador	Spacer Pièce d'écartement		
12	5000159489	1	pc	Führungsstift Pasador de guía	Pilot pin Goupille d'introduction	63,5	
13	5000207988	2	pc	Abstandsscheibe Arandela distanciador	Distance washer Rondelle intermédiaire	0,5	
14	5000159262	1	pc	Riemen Correa	Belt Courroie		
15	5000083026	3	pc	Schraube Tornillo	Screw Vis	M8x35	
16	5000159448	1	pc	Konsole Consola	Fan bracket Console		
17	5000207989	4	pc	Abstandsscheibe Arandela distanciador	Distance washer Rondelle intermédiaire	1,0	

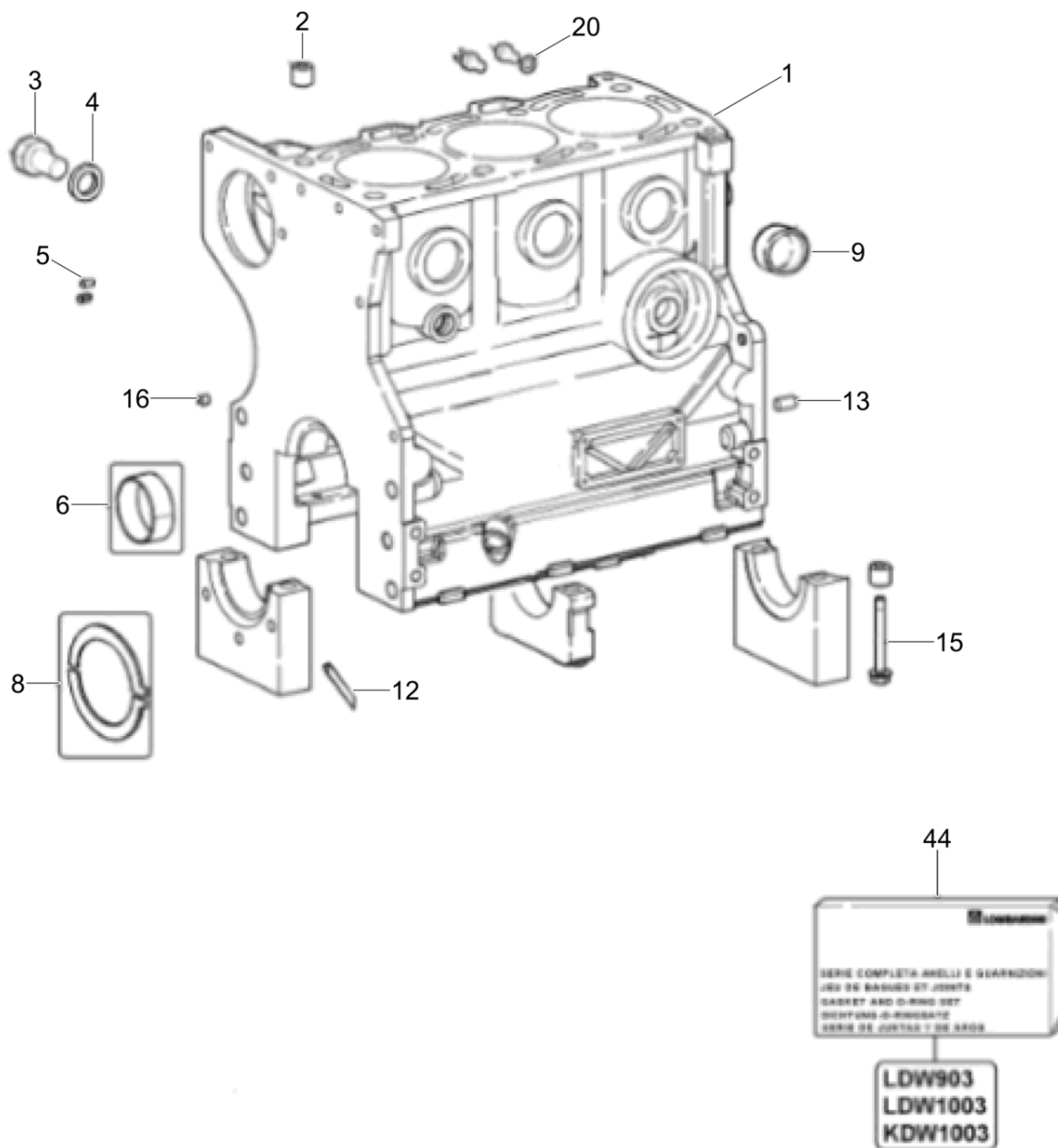

5100042343_01

Pos. Item	Artikel Nr. Item no.	Pc.	Unit	Beschreibung Descripción	Description Description	Abm. Dim.	Norm Standard
						Drehmoment Torque	Schmierstoff Lubricant
1	5200009453	1	pc	Kurbelgehäuse Cárter	Crankcase Carter		
2	5000159257	2	pc	Hülse Collar	Sleeve Douille		
3	5000206229	1	pc	Schraube Tornillo	Screw Vis		
4	5000082184	1	pc	Dichtring Anillo sellador	Ring seal Rondelle à étancher		
5	5000215522	1	pc	Stift Espiga	Pin Goupille		
6	5000155704	3	pc	Lager Cojinete	Bearing Palier		
6	5000155703	3	pc	Lager Cojinete	Bearing Palier		
6	5200009472	3	pc	Lager Rodamiento	Bearing Roulement		
8	5000159487	2	pc	Scheibe Disco	Disc Disque		
8	5000159486	2	pc	Scheibe Disco	Disc Disque		
8	5000159488	2	pc	Scheibe Disco	Disc Disque		
9	5000082335	4	pc	Schraubverschluß Tapón roscado	Plug (threaded) Bouchon		
12	5000159288	4	pc	Dichtung Junta	Gasket Joint		
13	5000159360	2	pc	Paßstift Espiga	Dowel pin Cheville		
15	5000159480	8	pc	Schraube Tornillo	Screw Vis		
16	5100042193	1	pc	Stopfen Tapón	Plug Bouchon		
20	5000082183	1	pc	Dichtring Anillo sellador	Copper washer Rondelle à étancher		
44	5000159397	1	pc	Dichtungssatz, Kurbelgehäuse Juego de juntas, cárter	Crankcase gasket set Jeu de joints, carter		

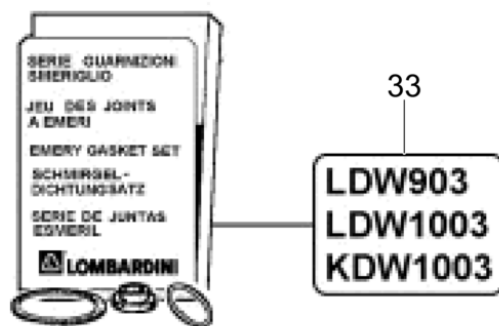
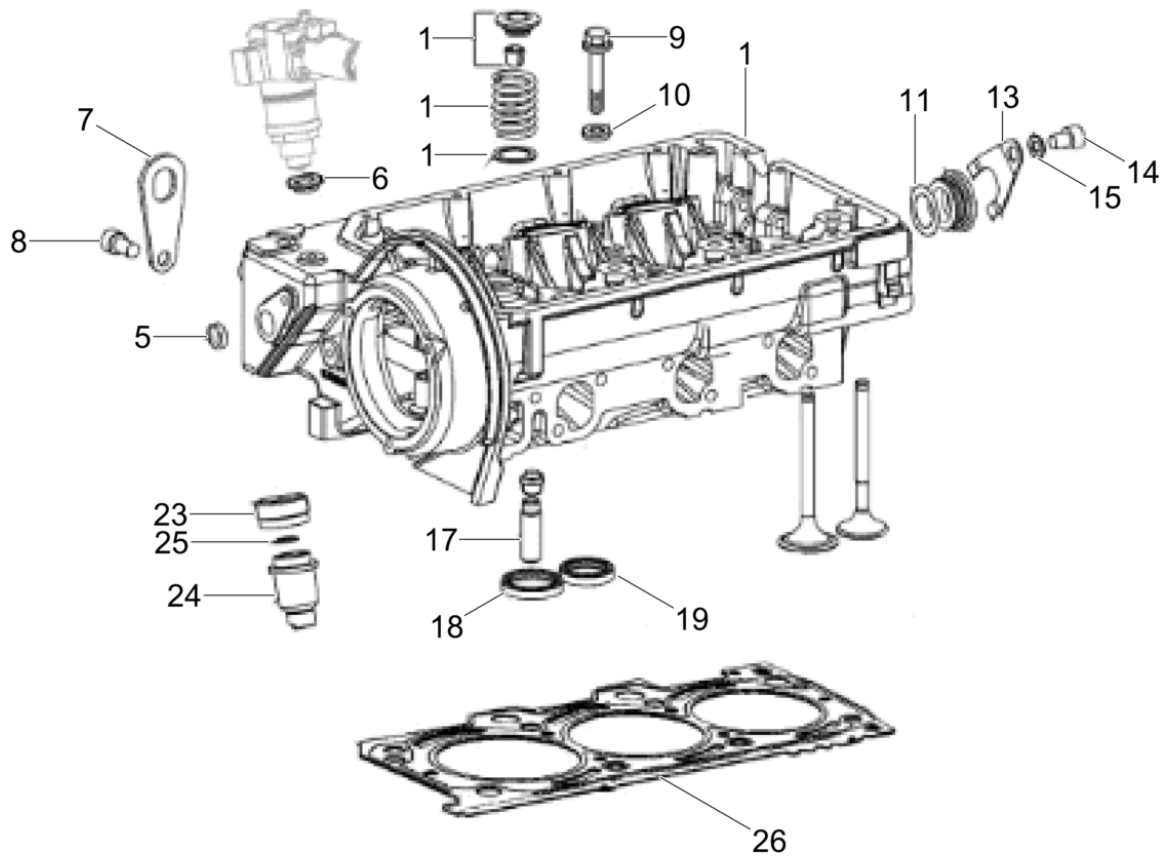

5100042344_01

Pos. Item	Artikel Nr. Item no.	Pc.	Unit	Beschreibung Descripción	Description Description	Abm. Dim.	Norm Standard
						Drehmoment Torque	Schmierstoff Lubricant
1	5000160388	1	pc	Zylinderkopf Culata	Cylinder head Culasse		
5	5000159449	2	pc	Stopfen Enchufe	Plug Prise		
6	5000159318	3	pc	Funkenfänger Parachispas	Spark arrester Pare-étincelles		
7	5000215524	2	pc	Aufhängung Punto para itar	Lifting point Suspension		
8	5000084156	1	pc	Schraube Tornillo	Screw Vis		
9	5000159479	8	pc	Bolzen Perno	Bolt Boulon		
10	5000159350	8	pc	Scheibe Arandela	Washer Rondelle		
11	5000159231	1	pc	O-Ring Anillo en forma de o	O-ring Joint torique		
13	5000159311	1	pc	Halter Soporte	Bracket Équerre		
14	5000159254	1	pc	Bolzen Perno	Bolt Boulon		
15	5000082292	1	pc	Scheibe Arandela	Washer Rondelle		
17	5000159303	6	pc	Ventilführung Guía de válvula	Valve guide Guide de soupape		
18	5000160381	3	pc	Sitz Des Einlassventils Asiento de la válvula de admisión	Seat-valve, intake Siège de la soupape		
19	5000160382	3	pc	Sitz Des Auslassventils Asiento de la válvula de escape	Seat-valve, exhaust Siège de la soupape		
23	5000159285	3	pc	Mutter Tuerca	Nut Ecrou		
24	5000215494	9	pc	Abstandsstück Espaciador	Spacer Pièce d'écartement		
25	5000160380	3	pc	Vorkammer Cámara de precombustión	Precombustion chamber Préchambre		
26	5100042194	1	pc	Zylinderkopfdichtung (3) Junta de culata del cilindro (3)	Cylinder head gasket (3) notch Joint de culasse de cylindre (1,63	
26	5100042195	1	pc	Zylinderkopfdichtung (2) Junta de culata del cilindro (2)	Cylinder head gasket (2) notch Joint de culasse de cylindre (1,53	
33	5200009477	1	pc	Dichtungssatz Juego de juntas	Gasket set Jeu de joints		

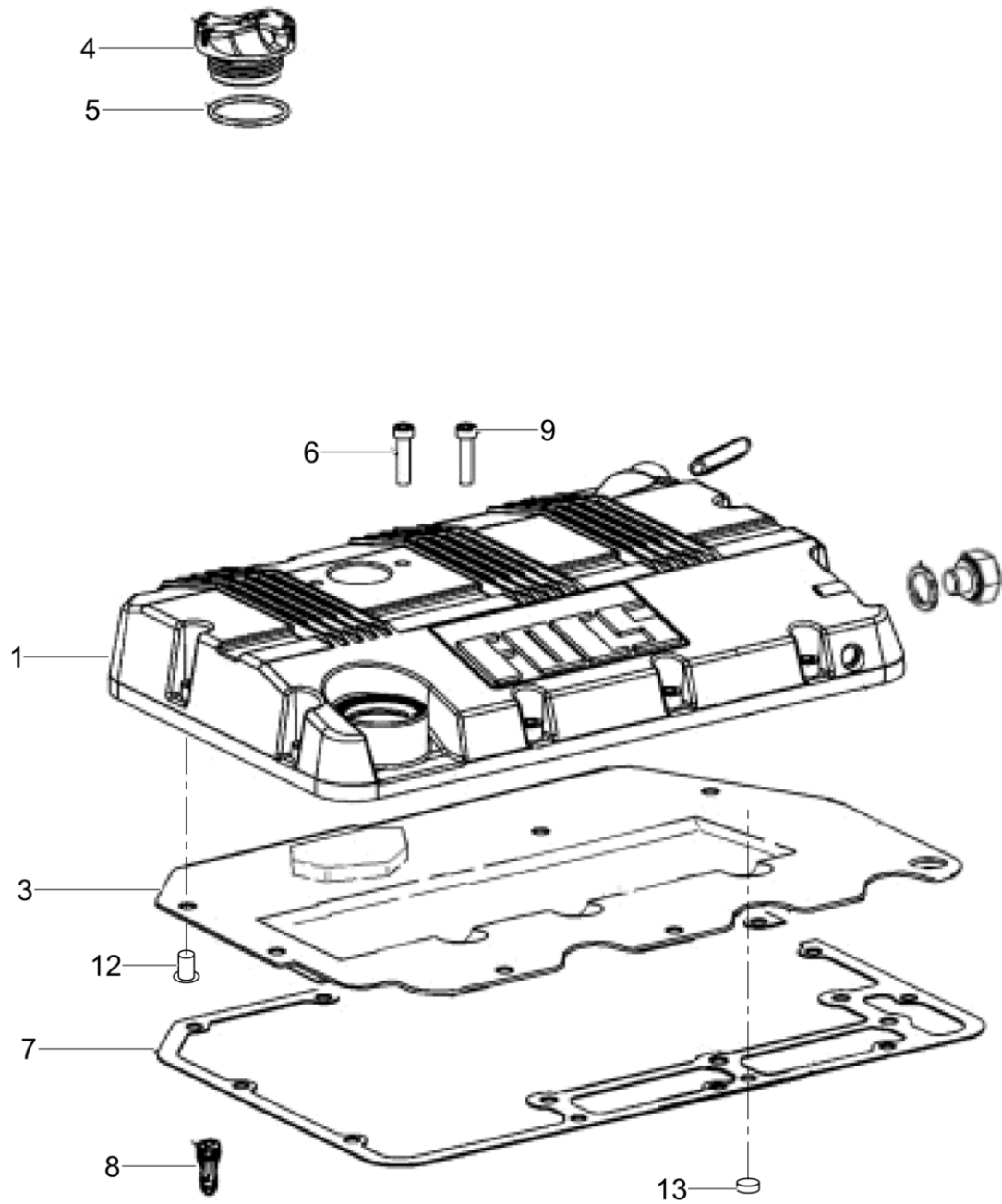

5100042346_01

Pos. Item	Artikel Nr. Item no.	Pc.	Unit	Beschreibung Descripción	Description Description	Abm. Dim.	Norm Standard
						Drehmoment Torque	Schmierstoff Lubricant
1	5000210346	1	pc	Ventilhaube Tapa de válvula	Valve cover Couvercle de soupape		
3	5000159305	1	pc	Leitblech Deflector	Baffle Déflecteur		
4	5000210347	1	pc	Kappe Tapa	Cap Couvercle		
5	5000206208	1	pc	O-Ring Anillo en forma de o	O-ring Joint torique		
6	5000215541	10	pc	Schraube Tornillo	Screw Vis		
7	5000160205	1	pc	Dichtung Junta	Gasket Joint		
8	5000159308	1	pc	Anschlußteil Conector	Connector Connexion		
9	5000215544	2	pc	Schraube Tornillo	Screw Vis		
12	5200015519	9	pc	Niet Remache	Rivet Rivet		
13	5000159455	1	pc	Stopfen Tapón	Push-in plug Bouchon		

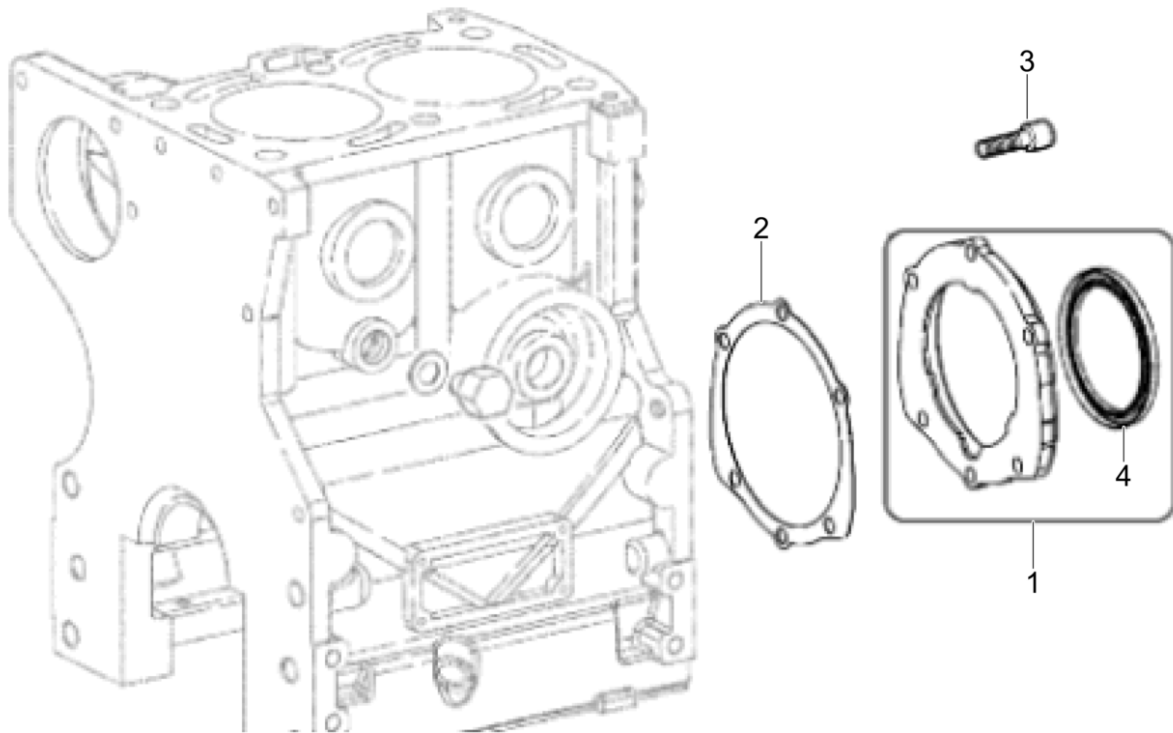

5100042347_01

Pos. Item	Artikel Nr. Item no.	Pc.	Unit	Beschreibung Descripción	Description Description	Abm. Dim.	Norm Standard
						Drehmoment Torque	Schmierstoff Lubricant
1	5000159281	1	pc	Blindflansch Palanca de cubierta	Flange cover Semelle		
2	5000159296	1	pc	Dichtung Junta	Gasket Joint		
3	5200023965	6	pc	Schraube Tornillo	Screw Vis		
4	5000103314	1	pc	Wellendichtring Anillo sellador	Ring seal Rondelle à étancher		

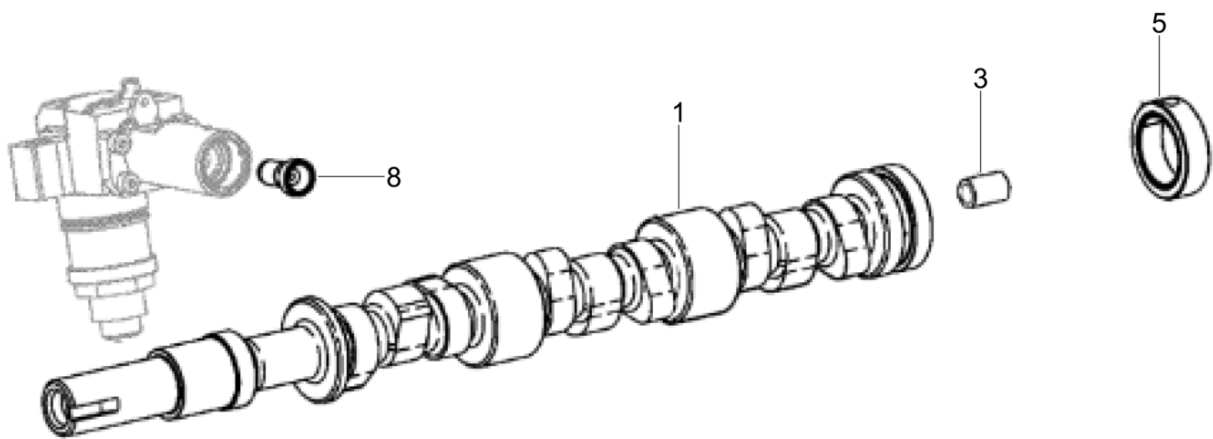

5100042360_01

Pos. Item	Artikel Nr. Item no.	Pc.	Unit	Beschreibung Descripción	Description Description	Abm. Dim.	Norm Standard
						Drehmoment Torque	Schmierstoff Lubricant
1	5000063700	6	pc	Flanschmutter Tuerca de reborde	Flange nut Ecrou de bride		
2	5000160379	3	pc	Einspritzpumpe Bomba de inyección	Injection pump Pompe à injection		
3	5200009479	6	pc	Gewindebolzen Perno prisionero	Stud Goujon		
4	5000159233	2	pc	O-Ring Anillo-o	O-ring Joint torique		
5	5100042196	1	pc	Platte Placa	Plate Plaque		
7	5000159300	3	pc	Scheibe Disco	Washer Rondelle		
9	5000159473	6	pc	Schraube Tornillo	Screw Vis		
10	5000159459	1	pc	Rohr Tubo	Pipe Conduit		
11	5000159237	2	pc	Ring Anillo	Ring Anneau		
12	5000160209	1	pc	Dichtung Junta de estanqueidad	Gasket Garniture		
13	5000160391	2	pc	Rückschlagventil Válvula de retención	Back pressure valve Soupape de retenue		
14	5000159302	2	pc	Dichtung Junta de estanqueidad	Gasket Garniture		
15	5200009480	1	pc	Abstandsstück Espaciador	Spacer Entretoise	2,00	
17	5000159278	2	pc	Abstandsstück Espaciador	Spacer Pièce d'écartement		
18	5000155710	2	pc	Düse Chicler	Jet Gicleur		
20	5000159238	2	pc	O-Ring Anillo-o	O-ring Bague-o		
22	5200009491	2	pc	Feder Resorte	Spring Ressort		
23	5200009492	2	pc	Dichtung Junta	Gasket Joint		
24	5000159236	2	pc	Ring Anillo	Ring Anneau		
25	5000159471	4	pc	Schraube Tornillo	Screw Vis		
26	5000159317	2	pc	Feder Resorte	Spring Ressort		
29	5000159242	2	pc	Klemme Abrazadera	Clamp Pince		
30	5200015520	2	pc	Überdruckventil Válvula de sobrepresión	Pressure valve Soupape de surpression		
31	5000159309	2	pc	Ausgleichscheibe Laminita	Shim Cale		

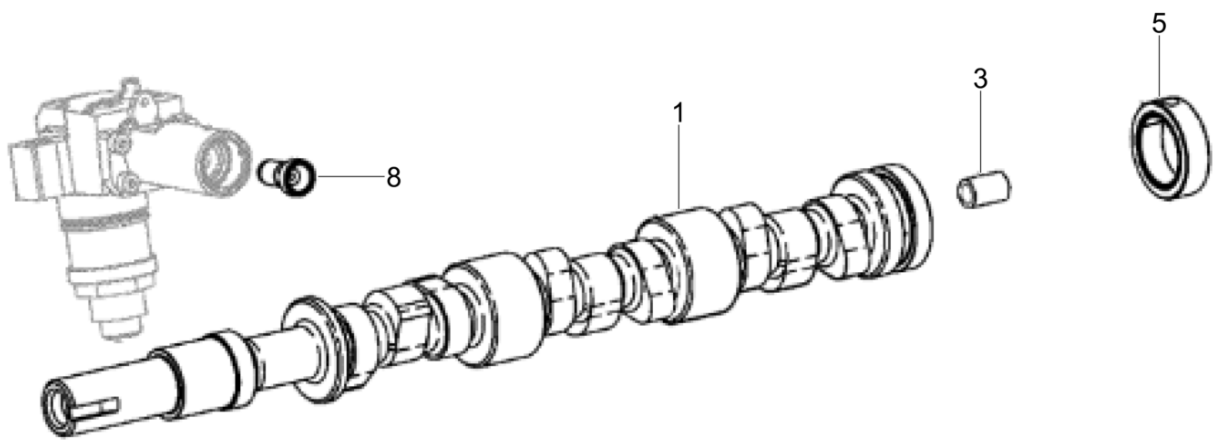

5100042360_01

Pos. Item	Artikel Nr. Item no.	Pc.	Unit	Beschreibung Descripción	Description Description	Abm. Dim.	Norm Standard
						Drehmoment Torque	Schmierstoff Lubricant
1	5000160751	1	pc	Nockenwelle Arbol de levas	Camshaft Arbre à cames		
3	5000160752	1	pc	Hülse Manguito	Sleeve Douille		
5	5000160753	1	pc	Einspritznocken Leva inyectora	Injector cam Came d'injection		
8	5000159246	2	pc	Stoßstange Levantaválvula	Push rod (valve lifter) Poussoir de soupape		

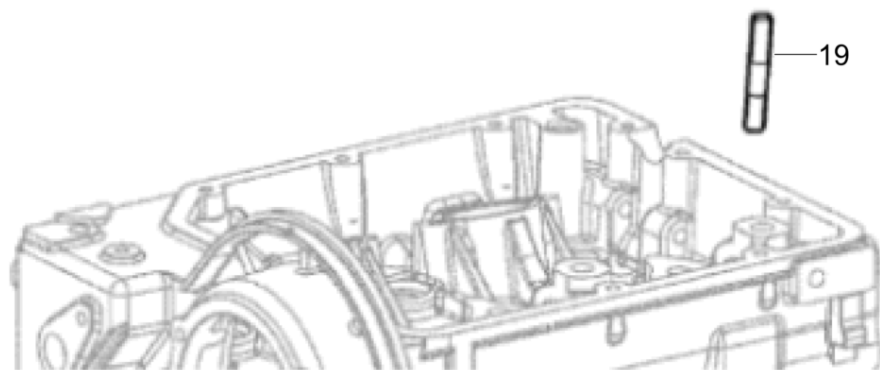
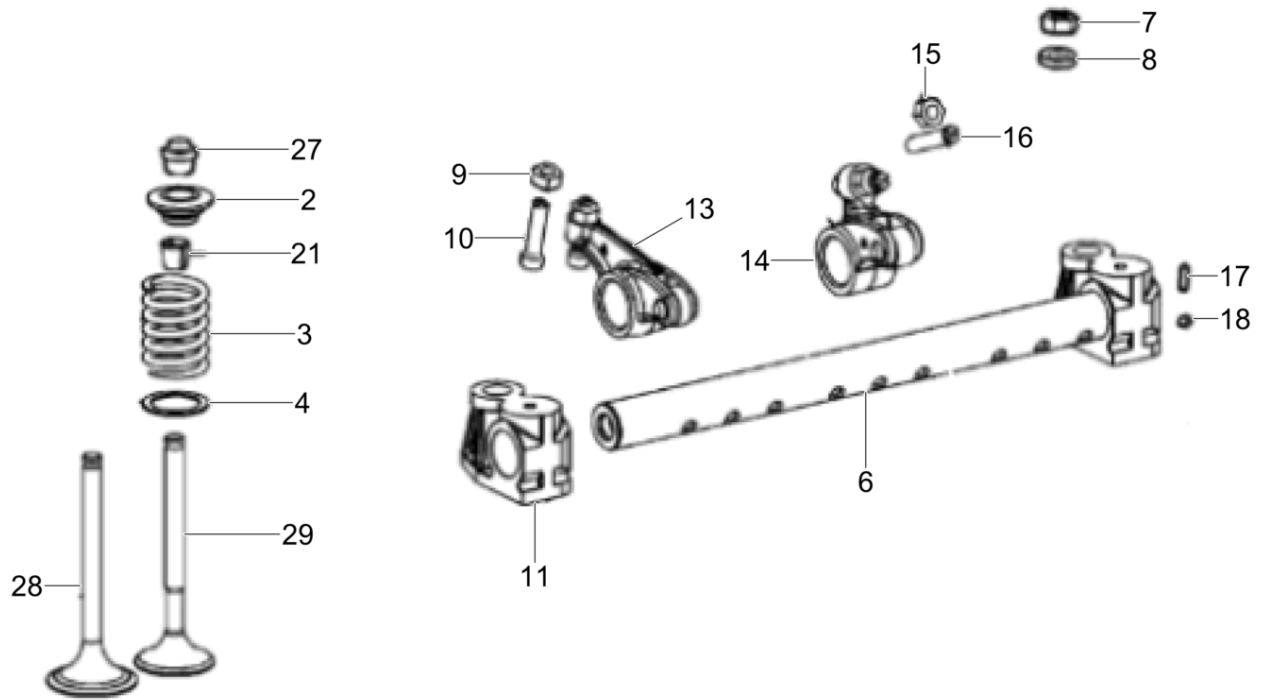

5100042361_01

Pos. Item	Artikel Nr. Item no.	Pc.	Unit	Beschreibung Descripción	Description Description	Abm. Dim.	Norm Standard
						Drehmoment Torque	Schmierstoff Lubricant
2	5000159328	4	pc	Federgehäuse Carcasa de resorte	Spring housing Logement du ressort		
3	5000160373	6	pc	Ventilfeder Resorte	Spring Ressort		
4	5000159351	6	pc	Scheibe Disco	Washer Rondelle		
6	5100042197	1	pc	Kipphebel Kpl. Balancín compl.	Rocker arm cpl. Culbuteur compl.		
7	5000083011	4	pc	Mutter Tuerca	Nut Ecrou		
8	5000159350	4	pc	Scheibe Arandela	Washer Rondelle		
9	5000159272	1	pc	Mutter Tuerca	Nut Écrou		
10	5000159482	1	pc	Schraube Tornillo	Screw Vis		
11	5000159447	4	pc	Kipphebelbolzenkonsole Soporte del eje de balancín	Shaft support Support de l'arbre de bascule		
13	5000159248	6	pc	Kipphebel Balancín	Rocker arm Culbuteur		
14	5000159249	3	pc	Kipphebel Einspritzdüse Inyector de balancines	Rocker arm injector L'injecteur de culbuteur		
15	5000159275	1	pc	Mutter Tuerca	Nut Ecrou		
16	5000159483	1	pc	Gewindebolzen Perno roscado	Threaded bolt Boulon fileté		
17	5000159443	1	pc	Stift Espiga	Pin Goupille		
18	5200009500	2	pc	Stopfen Tapón	Plug Bouchon		
19	5000159333	4	pc	Gewindebolzen Perno roscado	Threaded stud Boulon fileté		
21	5200015522	12	pc	Klemmring Anillo de sujeción	Locking ring Anneau serrure		
27	5000159297	6	pc	Dichtung Junta	Gasket Joint		
28	5000160390	3	pc	Einlaßventil Válvula de admisión	Intake valve Soupape d'admission		
29	5000160392	3	pc	Auslaßventil Válvula de escape	Outlet valve Soupape d'échappement		

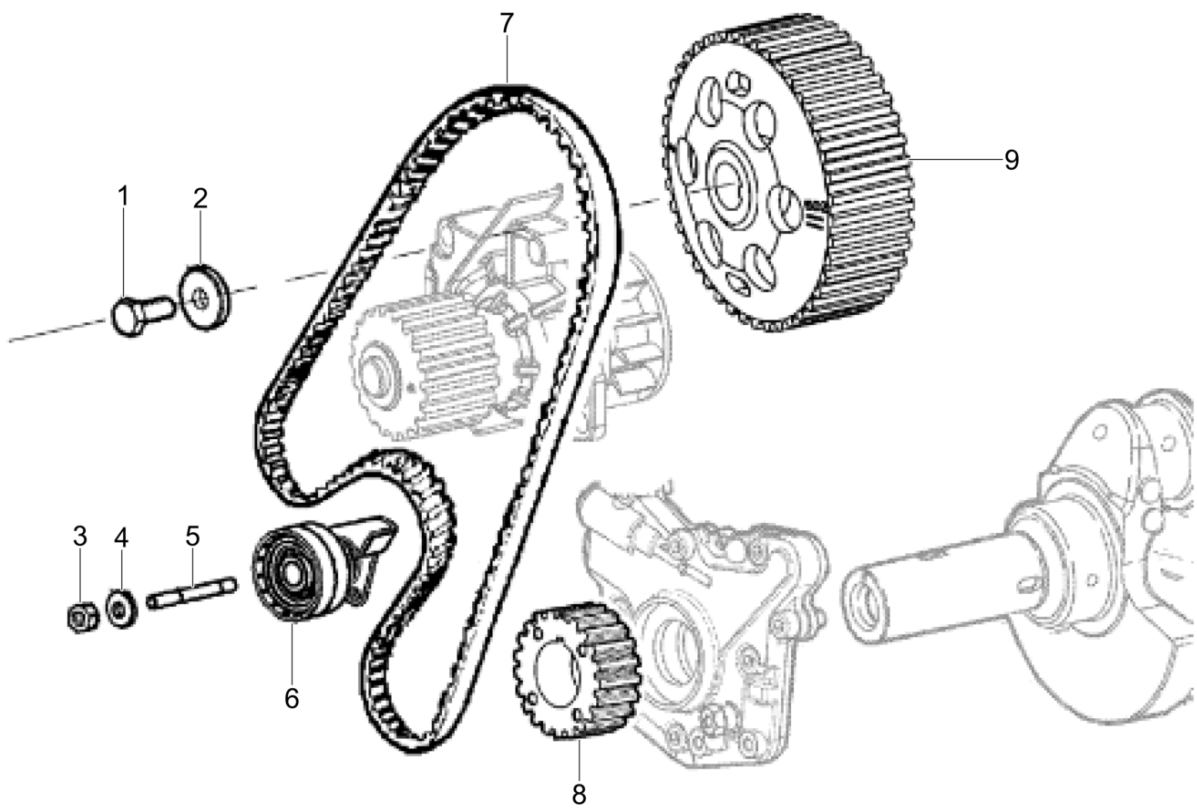

5100042362_01

Pos. Item	Artikel Nr. Item no.	Pc.	Unit	Beschreibung Descripción	Description Description	Abm. Dim.	Norm Standard
						Drehmoment Torque	Schmierstoff Lubricant
1	5000159481	1	pc	Schraube Tornillo	Screw Vis		
2	5000159349	1	pc	Scheibe Disco	Washer Rondelle		
3	5000083011	1	pc	Mutter Tuerca	Nut Ecrou		
4	5000159344	1	pc	Scheibe Disco	Washer Rondelle		
5	5000159334	1	pc	Gewindebolzen Perno roscado	Threaded stud Boulon fileté		
6	5000159284	1	pc	Spannrolle Polea tensora	Tensioner pulley Poulie de tension		
7	5000155697	1	pc	Synchronriemen Correa de sincronización	Timing belt Courroie de synchronisation		
8	5000159336	1	pc	Riemenscheibe Polea	Belt pulley Poulie		
9	5000159338	1	pc	Riemenscheibe Polea	Belt pulley Poulie		

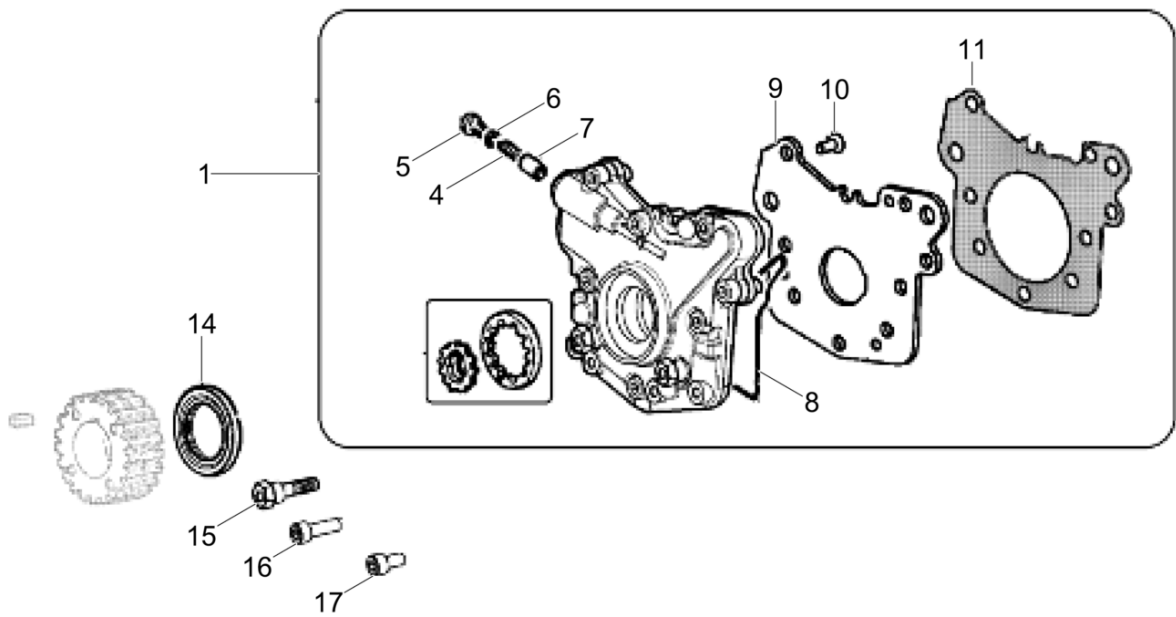

5100042363_01

Pos. Item	Artikel Nr. Item no.	Pc.	Unit	Beschreibung Descripción	Description Description	Abm. Dim.	Norm Standard
						Drehmoment Torque	Schmierstoff Lubricant
1	5000155735	1	pc	Ölpumpe Kpl. Bomba de aceite compl.	Oil pump cpl. Pompe à huile compl.		
4	5000159312	1	pc	Feder Resorte	Spring Ressort		
5	5000159450	1	pc	Schraubverschluß Cierre roscada	Screw locking Fermeture de vissage		
6	5000082184	1	pc	Dichtring Anillo sellador	Ring seal Rondelle à étancher		
7	5000159330	1	pc	Stange Varilla	Rod Tige		
8	5000160178	1	pc	O-Ring Anillo-o	O-ring Joint torique		
10	5000159478	3	pc	Schraube Tornillo	Screw Vis		
11	5000215709	1	pc	Dichtung Junta de estanqueidad	Gasket Garniture		
14	5000155734	1	pc	Dichtungsring Anillo sellador	Ring seal Rondelle à étancher		
15	5000159484	2	pc	Schraube Tornillo	Screw Vis		
16	5000215479	1	pc	Sechskantschraube Tornillo de cabeza hexagonal	Hexagonal head cap screw Vis à tête hexagonale		
17	5000084169	6	pc	Schraube Tornillo	Screw Vis		

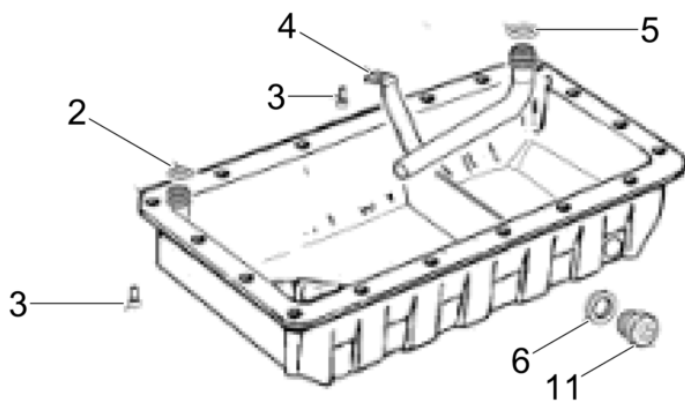
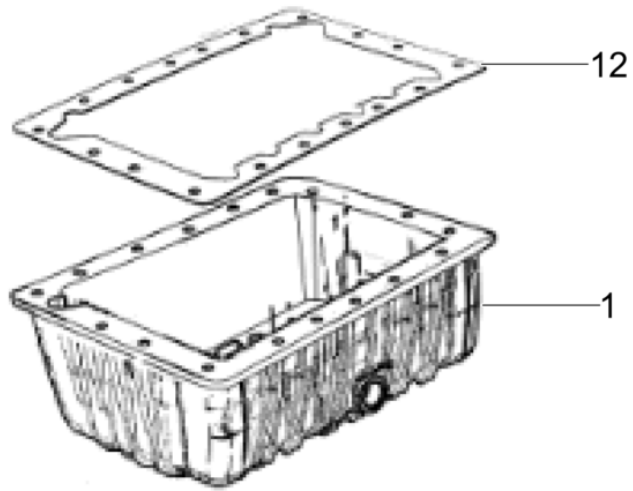

5100042364_01

Pos. Item	Artikel Nr. Item no.	Pc.	Unit	Beschreibung Descripción	Description Description	Abm. Dim.	Norm Standard
						Drehmoment Torque	Schmierstoff Lubricant
1	5000155738	1	pc	Ölwanne Colector de aceite	Oil pan Cuvette-carter à huile		
2	5000159228	1	pc	Öldichtung Junta de aceite	Oil seal Joint d'huile		
3	5000159253	19	pc	Bolzen Perno	Bolt Boulon		
4	5000155737	1	pc	Schlauch Manguera	Hose Tuyau		
5	5000159235	1	pc	O-Ring Anillo-o	O-ring Joint torique		
6	5000159568	2	pc	Kupferscheibe Anillo de cobre	Copper washer Rondelle en cuivre		
11	5000159452	2	pc	Stopfen Tapón	Plug Bouchon	M18	
12	5000159291	1	pc	Dichtung Junta	Gasket Joint		

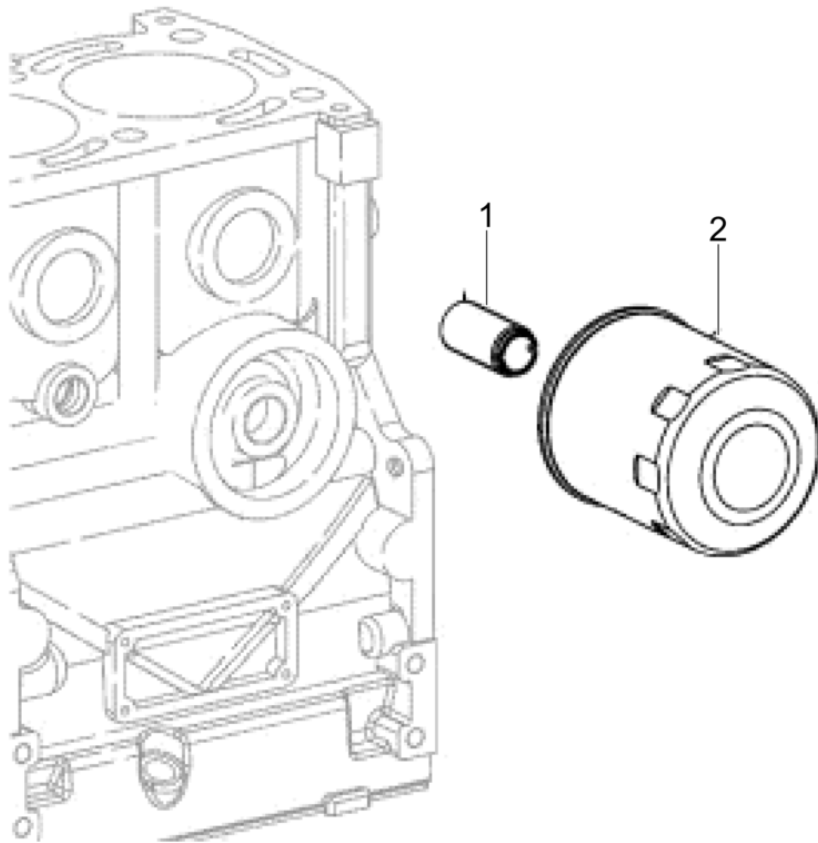

5100042365_01

Pos. Item	Artikel Nr. Item no.	Pc.	Unit	Beschreibung Descripción	Description Description	Abm. Dim.	Norm Standard
						Drehmoment Torque	Schmierstoff Lubricant
1	5000159341	1	pc	Ölfilterschraubung Unión de filtro de aceite de aceite	Fitting-oil filter Raccord de filtre d'huile		
2	5200015526	1	pc	Ölfiter Filtro de aceite	Oil filter Filtre d'huile		

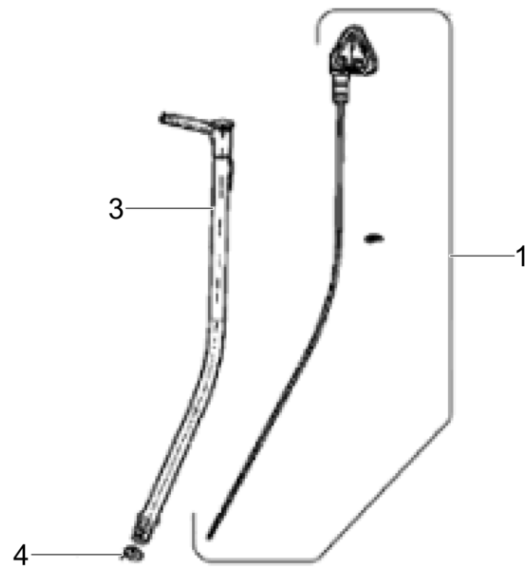
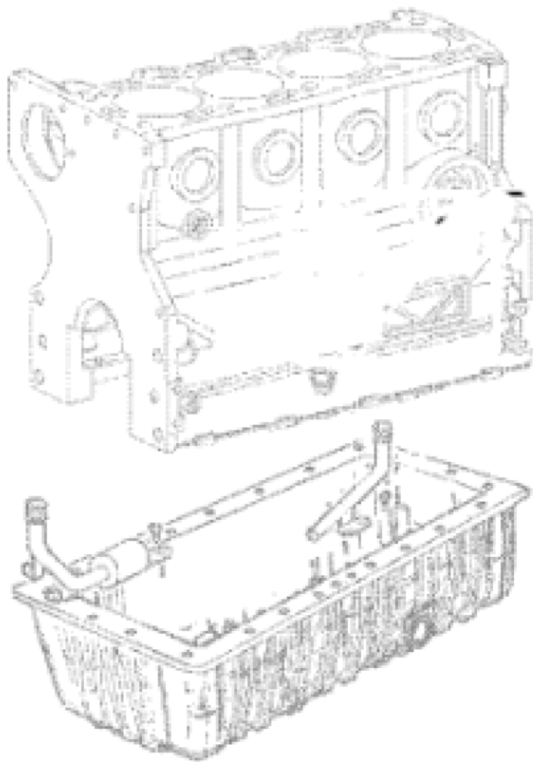

5100042366_01

Pos. Item	Artikel Nr. Item no.	Pc.	Unit	Beschreibung Descripción	Description Description	Abm. Dim.	Norm Standard
						Drehmoment Torque	Schmierstoff Lubricant
1	5200009507	1	pc	Ölpeilstab Indicador del nivel de aceite	Oil dipstick Règlette-jauge d'huile		
3	5000155739	1	pc	Schutz Protección	Protection Protection		
4	5200009508	2	pc	O-Ring Anillo-o	O-ring Joint torique		

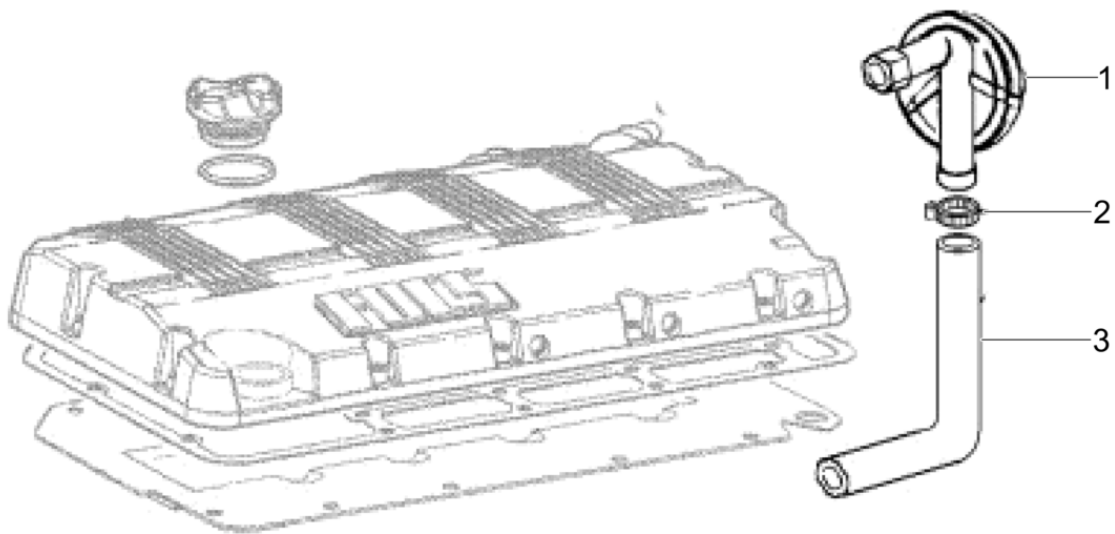

5100042367_01

Pos. Item	Artikel Nr. Item no.	Pc.	Unit	Beschreibung Descripción	Description Description	Abm. Dim.	Norm Standard
						Drehmoment Torque	Schmierstoff Lubricant
1	5000155745	1	pc	Überdruckventil Válvula de sobrepresión	Pressure valve Soupape de surpression		
2	5000160201	2	pc	Schelle Abrazadera	Clamp Attache		
3	5000159460	1	pc	Rohr Tubo	Tube Tube		

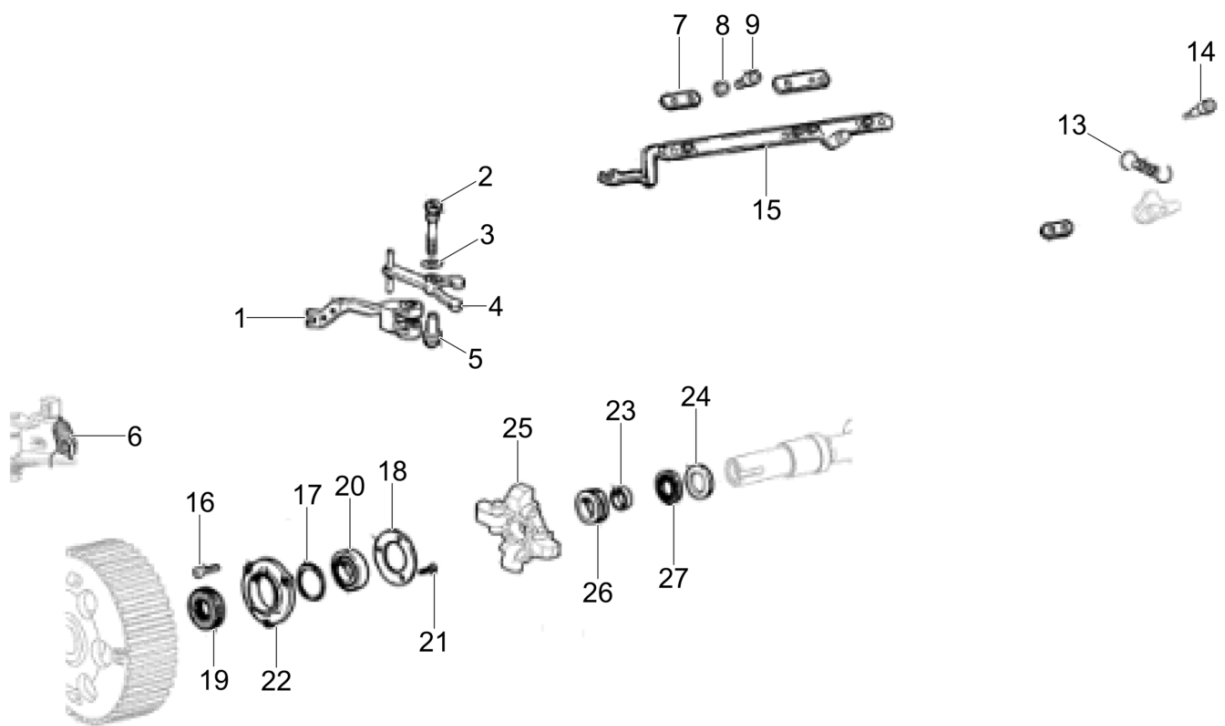

5100042369_01

Pos. Item	Artikel Nr. Item no.	Pc.	Unit	Beschreibung Descripción	Description Description	Abm. Dim.	Norm Standard
						Drehmoment Torque	Schmierstoff Lubricant
1	5000159304	1	pc	Reglerhebel Kpl. Palanca de regulador cpl.	Governor lever cpl. Lever régulateur cpl.		
2	5000159321	1	pc	Stift Espiga	Pin Goupille		
3	5000159229	1	pc	Öldichtung Junta de aceite	Oil seal Joint d'huile		
5	5000215480	1	pc	Hülse Collar	Collar Douille		
6	5000215507	1	pc	Feder Resorte	Spring Ressort		
7	5200009512	1	pc	Platte Placa	Plate Plaque		
8	5000215520	2	pc	Scheibe Disco	Washer Rondelle		
9	5000159477	4	pc	Schraube Tornillo	Screw Vis		
13	5000159315	1	pc	Feder Resorte	Spring Ressort		
14	5000211941	3	pc	Schraube Tornillo	Screw Vis		
15	5000159245	1	pc	Gestänge Varillaje	Linkage Tringles		
16	5000159467	3	pc	Schraube Tornillo	Screw Vis		
17	5000159239	1	pc	O-Ring Anillo-o	O-ring Joint torique		
18	5000159324	1	pc	Anlaufscheibe Arandela tope	Check disc Disque		
19	5000159240	1	pc	Lippendichtung Retén labial	Lip seal Joint à lèvres		
20	5000159267	1	pc	Lager Rodamiento	Bearing Roulement		
21	5200009514	3	pc	Schraube Tornillo	Screw Vis		
22	5000159265	1	pc	Deckel Cubierta	Cover Couvercle		
23	5000159251	1	pc	Hülse Collar	Collar Douille		
24	5000215517	1	pc	Anlaufscheibe Arandela tope	Check disc Disque		
25	5000155698	1	pc	Drehzahlregler Controlador de velocidad	Speed control module Régulateur de vitesse		
26	5000215506	1	pc	Hülse Collar	Collar Douille		
27	5200009517	1	pc	Lager Rodamiento	Bearing Roulement		

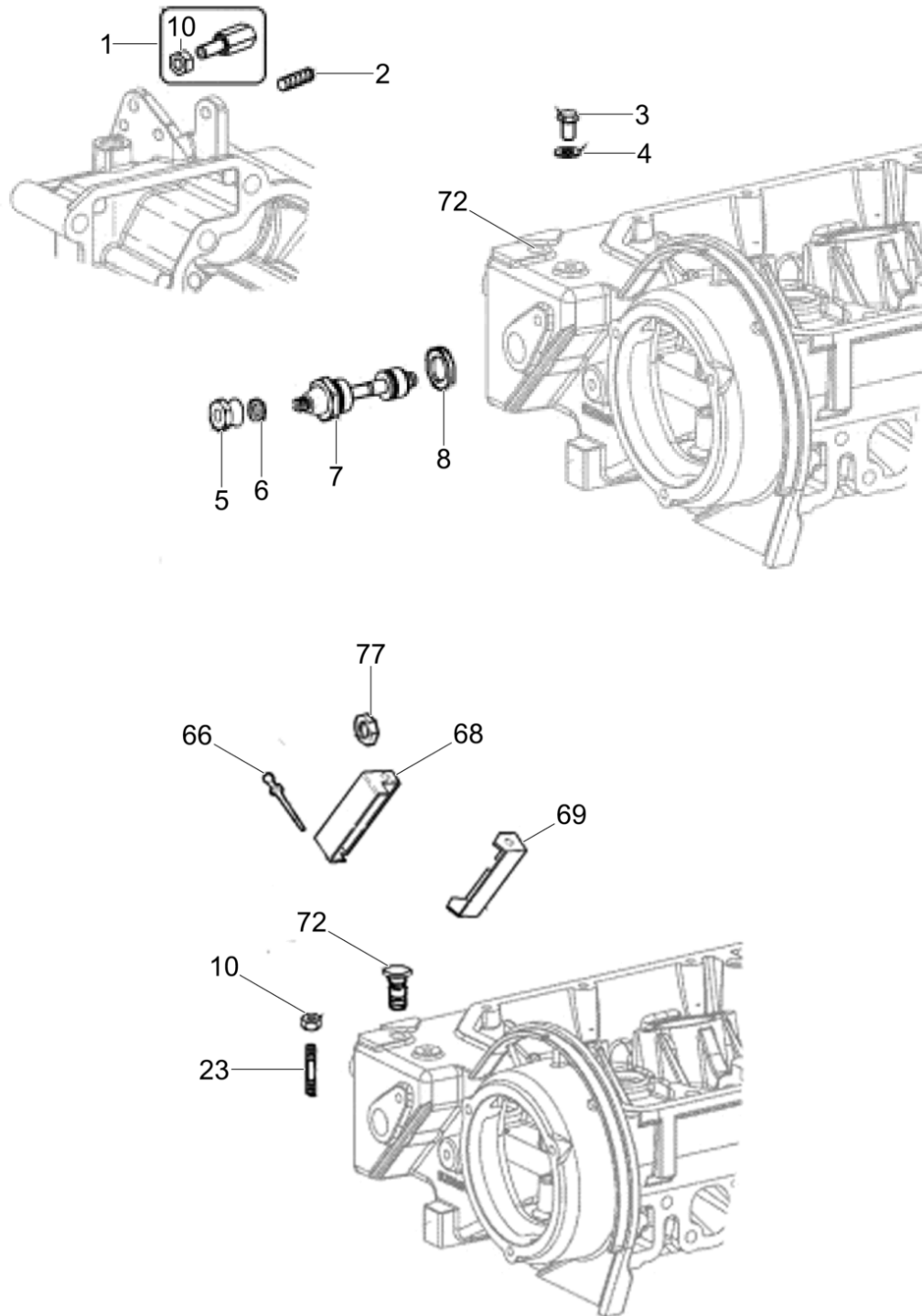

5100042370_01

Pos. Item	Artikel Nr. Item no.	Pc.	Unit	Beschreibung Descripción	Description Description	Abm. Dim.	Norm Standard
						Drehmoment Torque	Schmierstoff Lubricant
1	5000159457	1	pc	Schraube Tornillo	Screw Vis		
2	5000215543	1	pc	Schraube Tornillo	Screw Vis		
3	5000084131	1	pc	Schraube Tornillo	Screw Vis		
4	5000083995	1	pc	Scheibe Arandela	Washer Rondelle		
5	5000150038	1	pc	Mutter Tuerca	Nut Écrou		
6	5000209012	1	pc	Sechskantmutter Tuerca hexagonal	Hexagon nut Écrou hexagonal	M6	
7	5100042198	1	pc	Adapter Adaptador	Adapter Raccord		
8	5000159292	1	pc	Dichtung Junta de estanqueidad	Gasket Garniture		
9	5000082291	1	pc	Scheibe Arandela	Washer Rondelle		
10	5000159272	1	pc	Mutter Tuerca	Nut Écrou		
23	5100042199	1	pc	Gewindebolzen Perno prisionero	Stud Goujon	M6 x 16	
66	5000215519	3	pc	Niet Remache	Rivet Rivet		
68	5100029702	1	pc	Schutzplatte Placa de seguridad	Safety plate Plaque de sécurité		
69	5100029703	1	pc	Schutzplatte Placa de seguridad	Safety plate Plaque de sécurité		
72	5000215528	1	pc	Stopfen Tapón	Plug Bouchon		
77	5000159276	1	pc	Mutter Tuerca	Nut Écrou		

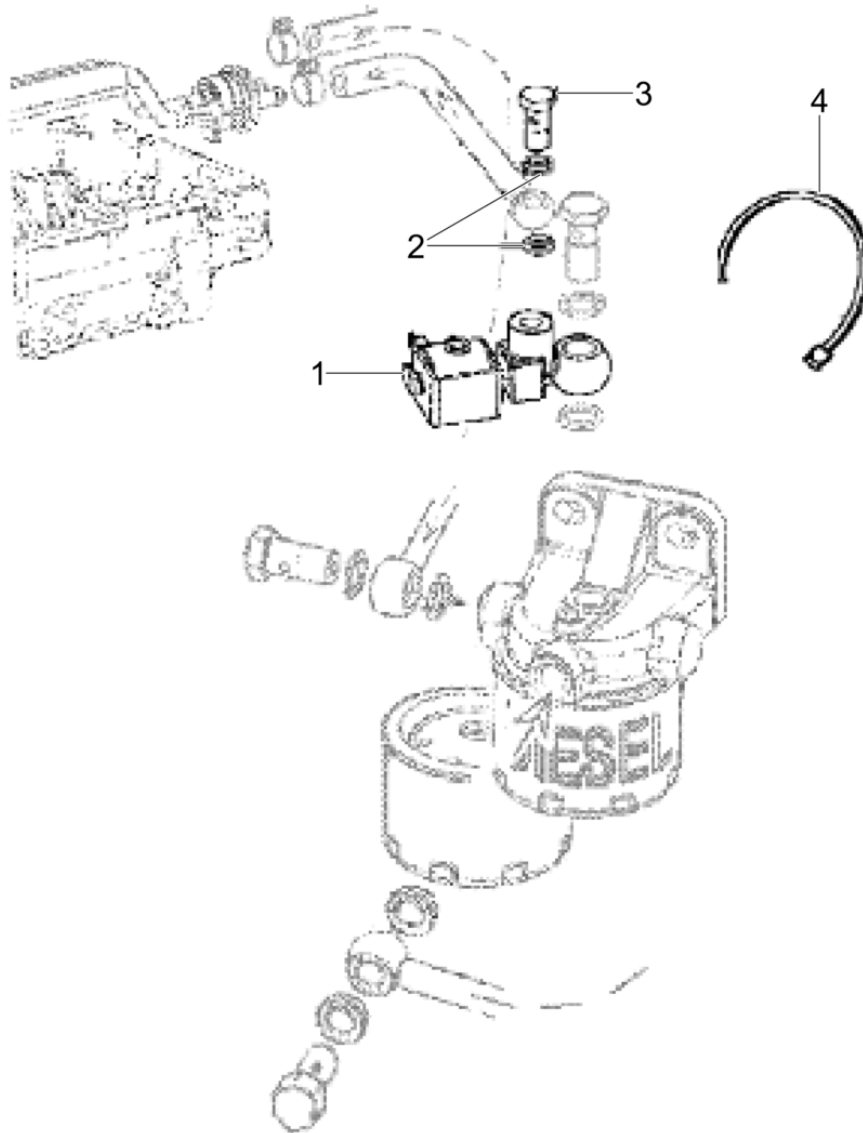

5100042371_01

Pos. Item	Artikel Nr. Item no.	Pc.	Unit	Beschreibung Descripción	Description Description	Abm. Dim.	Norm Standard
						Drehmoment Torque	Schmierstoff Lubricant
1	5000155711	1	pc	Kraftstoffventil Grifo de combustible	Fuel valve Robinet de carburant		
2	5000082183	2	pc	Dichtring Anillo sellador	Copper washer Rondelle à étancher		
3	5000082105	1	pc	Hohlschraube Perno hueco	Banjo bolt Boulon creux à filet femelle		
4	5000215486	1	pc	Manschette Collar	Collar Collet		

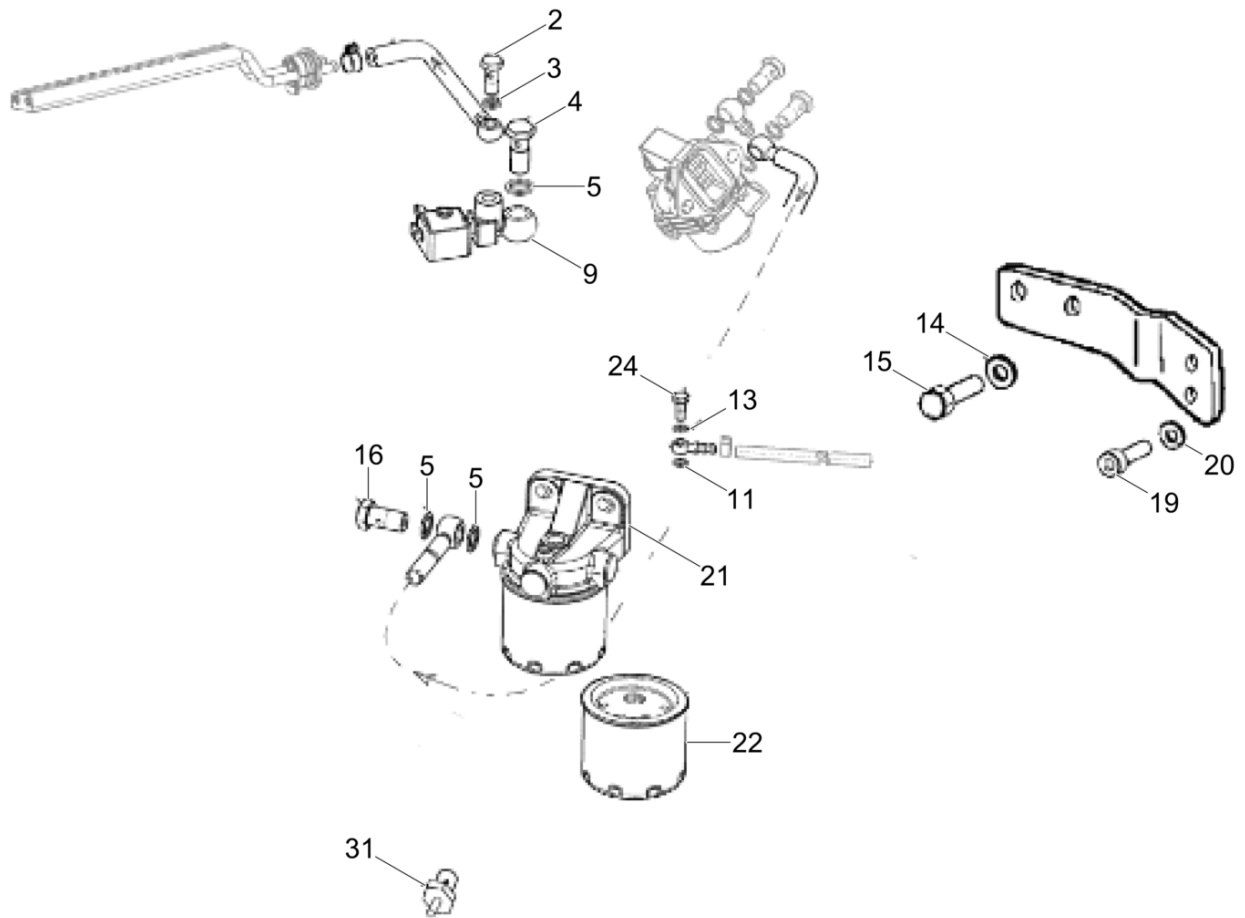

5100042372_01

Pos. Item	Artikel Nr. Item no.	Pc.	Unit	Beschreibung Descripción	Description Description	Abm. Dim.	Norm Standard
						Drehmoment Torque	Schmierstoff Lubricant
2	5000082105	1	pc	Hohlschraube Perno hueco	Banjo bolt Boulon creux à filet femelle		
3	5000082183	1	pc	Dichtring Anillo sellador	Copper washer Rondelle à étancher		
4	5000159250	1	pc	Hohlschraube Perno hueco	Banjo bolt Boulon creux à filet femelle		
5	5000082185	6	pc	Kupferscheibe Arandela de cobre	Copper washer Rondelle en cuivre		
9	5000155711	1	pc	Kraftstoffventil Grifo de combustible	Fuel valve Robinet de carburant		
11	5000203362	1	pc	Nippel Boquilla roscada	Nipple Raccord fileté		
13	5000083995	2	pc	Scheibe Arandela	Washer Rondelle		
14	5000160231	2	pc	Scheibe Disco	Washer Rondelle		
15	5000082100	2	pc	Schraube Tornillo	Screw Vis	M10 x 22	
16	5000082107	1	pc	Hohlschraube Perno hueco	Banjo bolt Boulon creux à filet femelle		
19	5000160363	2	pc	Schraube Tornillo	Screw Vis	M8 x 20	
20	5000160235	2	pc	Scheibe Arandela	Washer Rondelle		
21	5000205200	1	pc	Kraftstofffilter Kpl. Filtro de combustible compl.	Fuel filter cpl. Filtre à carburant compl.		
22	5200023966	1	pc	Filterpatrone Elemento	Fuel filter Cartouche		
24	5000084231	1	pc	Schraube Tornillo	Screw Vis		
31	5000205203	1	pc	Hohlschraube Tornillo hueco	Banjo bolt Boulon creux à filet femelle		

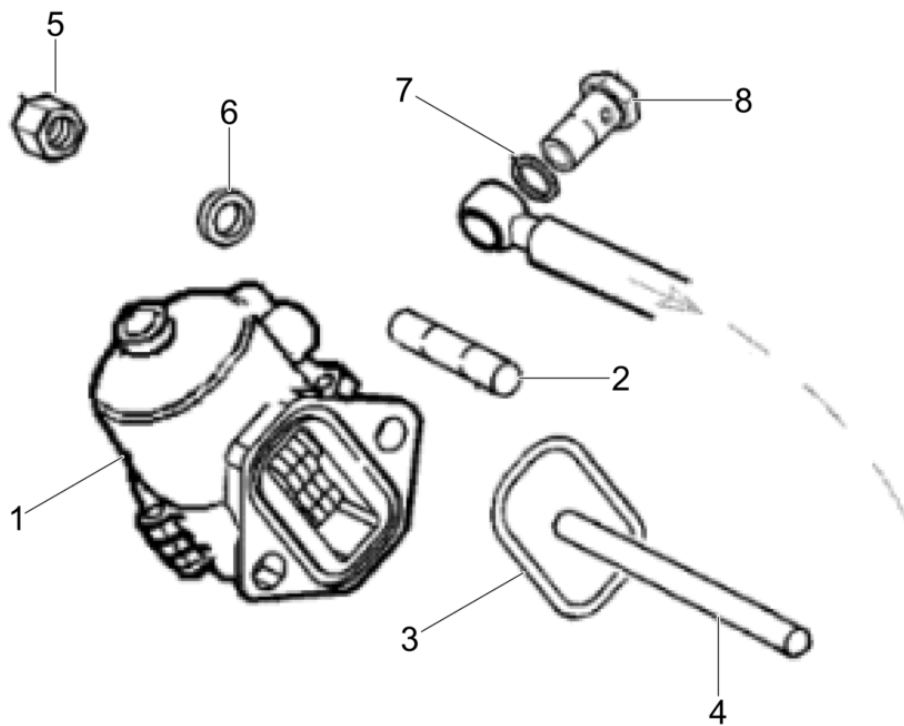

5100042373_01

Pos. Item	Artikel Nr. Item no.	Pc.	Unit	Beschreibung Descripción	Description Description	Abm. Dim.	Norm Standard
						Drehmoment Torque	Schmierstoff Lubricant
1	5000155706	1	pc	Kraftstoffpumpe Bomba de combustible	Fuel pump Pompe à essence		
2	5000082266	2	pc	Stiftschraube Perno prisionero	Stud Boulon		
3	5000110759	1	pc	Dichtung Junta	Seal Joint		
4	5000160757	1	pc	Stange Varillae	Rod Tige		
5	5000063700	2	pc	Flanschmutter Tuerca de reborde	Flange nut Ecrou de bride		
6	5000082285	2	pc	Scheibe Arandela	Washer Rondelle		
7	5000082183	4	pc	Dichtring Anillo sellador	Copper washer Rondelle à étancher		
8	5000082105	2	pc	Hohlschraube Perno hueco	Banjo bolt Boulon creux à filet femelle		

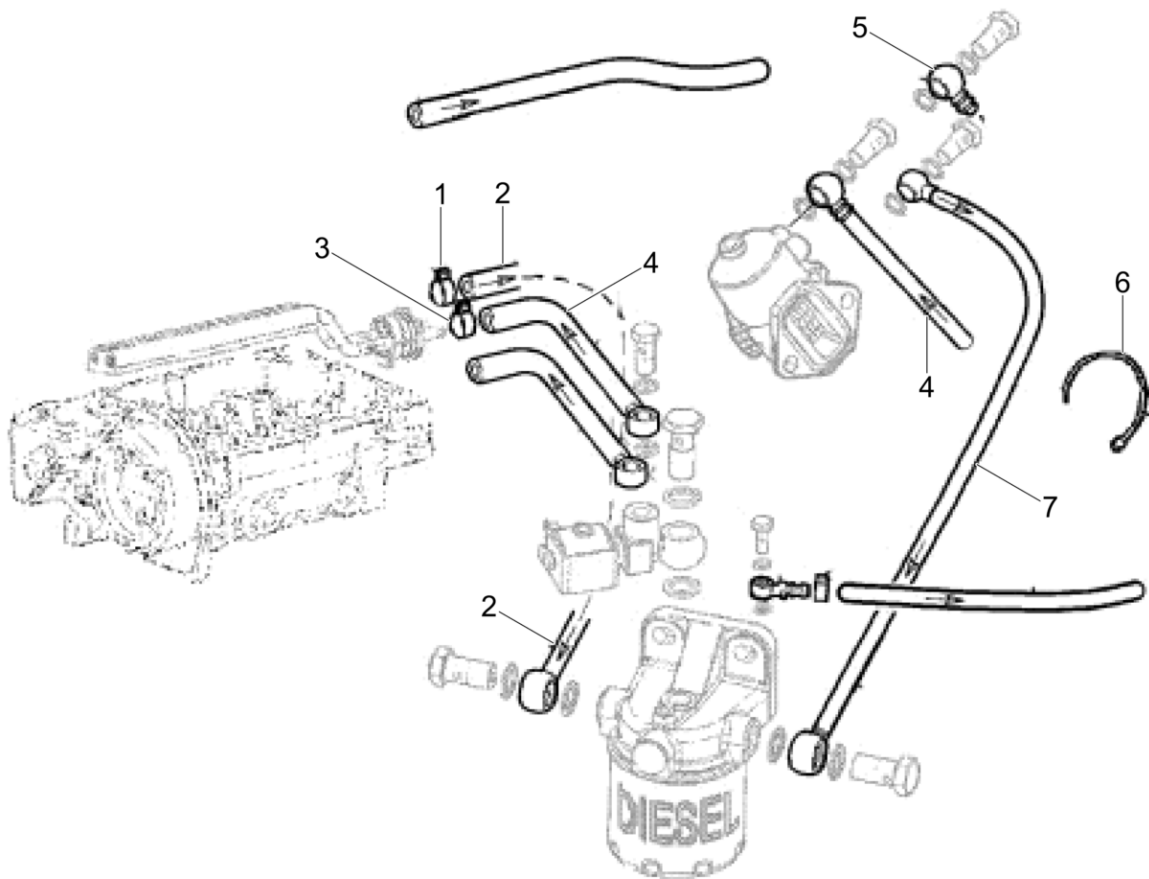

5100042374_01

Pos. Item	Artikel Nr. Item no.	Pc.	Unit	Beschreibung Descripción	Description Description	Abm. Dim.	Norm Standard
						Drehmoment Torque	Schmierstoff Lubricant
1	5000082155	1	pc	Schelle Abrazadera	Clamp Collier		
2	5000205202	1	pc	Kraftstoffleitung Manguera de combustible	Fuel line Conduit de carburant	ID 6, OD 12, 738	
3	5000215704	1	pc	Schelle Abrazadera	Clamp Attache		
4	5000210454	1	pc	Kraftstoffleitung Manguera de combustible	Fuel hose Tuyau de carburant	ID 6, OD 12, 680	
5	5000159342	1	pc	Schlauchverschraubung Unión de manguera	Hose fitting Raccord de tuyau		
6	5000215486	3	pc	Manschette Collar	Collar Collet		
7	5000209978	1	pc	Kraftstoffleitung Manguera de combustible	Fuel hose Tuyau de carburant	ID 6, OD 12, 680	

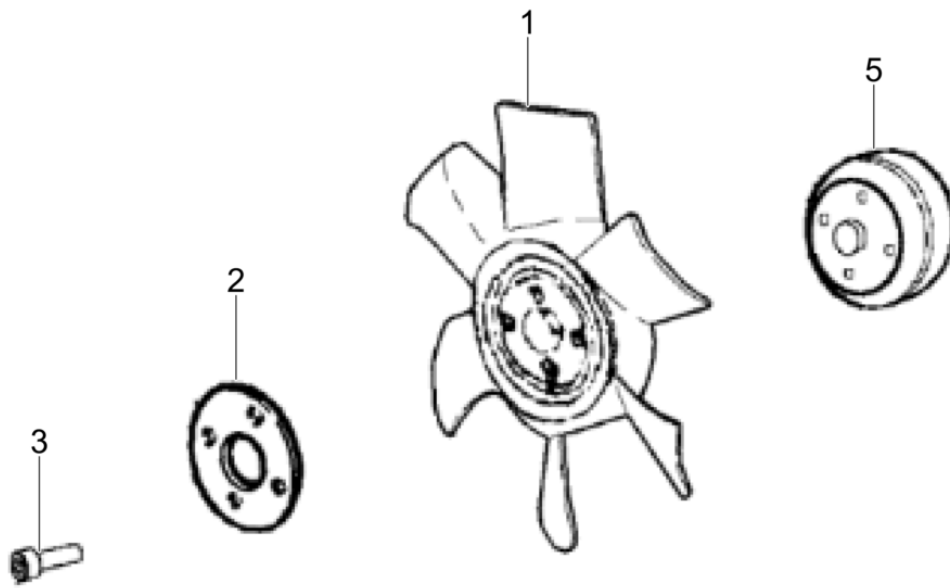

5100042375_01

Pos. Item	Artikel Nr. Item no.	Pc.	Unit	Beschreibung Descripción	Description Description	Abm. Dim.	Norm Standard
						Drehmoment Torque	Schmierstoff Lubricant
1	5000159466	1	pc	Gebläserad Ventilador	Fan Ventilateur		
2	5000159323	1	pc	Platte Placa	Plate Plaque		
3	5000207992	4	pc	Schraube Tornillo	Screw Vis		
5	5000215498	1	pc	Flansch Brida	Flange Bride	43,5mm	

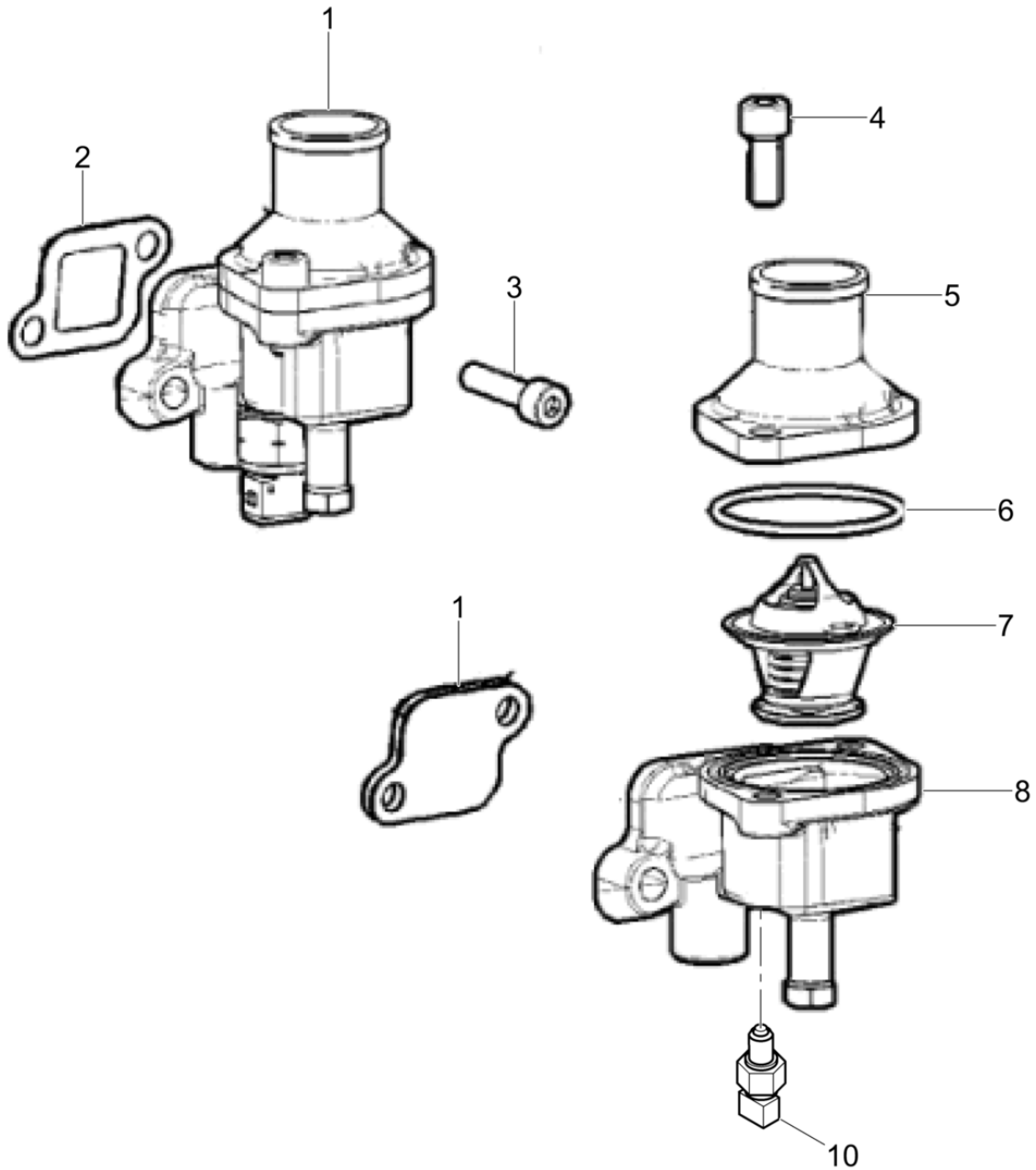

5100042376_01

Pos. Item	Artikel Nr. Item no.	Pc.	Unit	Beschreibung Descripción	Description Description	Abm. Dim.	Norm Standard
						Drehmoment Torque	Schmierstoff Lubricant
1	5000160372	1	pc	Gehäuse Caja	Housing Carter		
2	5000207003	1	pc	Dichtung Junta	Gasket Joint		
3	5000159476	2	pc	Schraube Tornillo	Screw Vis		
4	5000084169	2	pc	Schraube Tornillo	Screw Vis		
5	5000159266	1	pc	Thermostatdeckel Tapa del termóstato	Thermostat cover Couvercle du thermostat		
6	5000159232	1	pc	O-Ring Anillo-o	O-ring Joint torique		
7	5000207002	1	pc	Thermostatventil Válvula de gobierno termostático	Valve-thermostat Soupape thermostatique		
8	5000211375	1	pc	Gehäuse Carcasa	Thermostat housing Enveloppe		
10	5000160387	1	pc	Temperatursensoreinheit Unidad de alerta de temperatura	Temperature sensor Appareil d'alerte de températu		
12	5000159299	1	pc	Kupferscheibe Arandela de cobre	Copper washer Rondelle en cuivre		

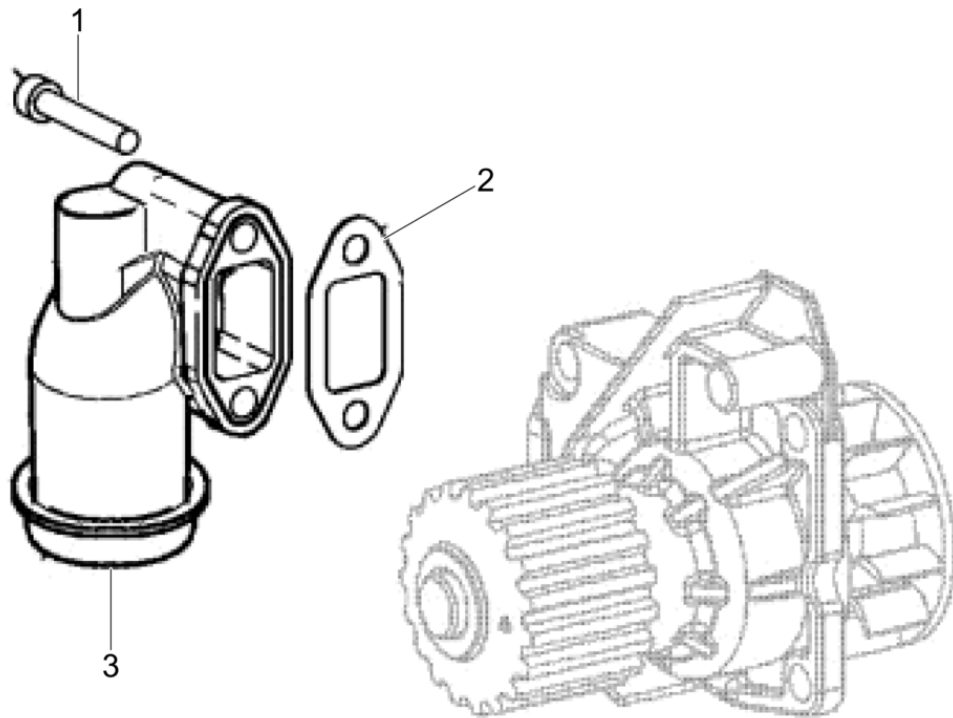

5100042377_01

Pos. Item	Artikel Nr. Item no.	Pc.	Unit	Beschreibung Descripción	Description Description	Abm. Dim.	Norm Standard
						Drehmoment Torque	Schmierstoff Lubricant
1	5000160362	2	pc	Schraube Tornillo	Screw Vis		
2	5000159293	1	pc	Dichtung Junta	Gasket Joint		
3	5000155729	1	pc	Flansch-Schlauch/Wasser Brida-manguera/agua	Hose/water flange Collerette-tuyau/eau		

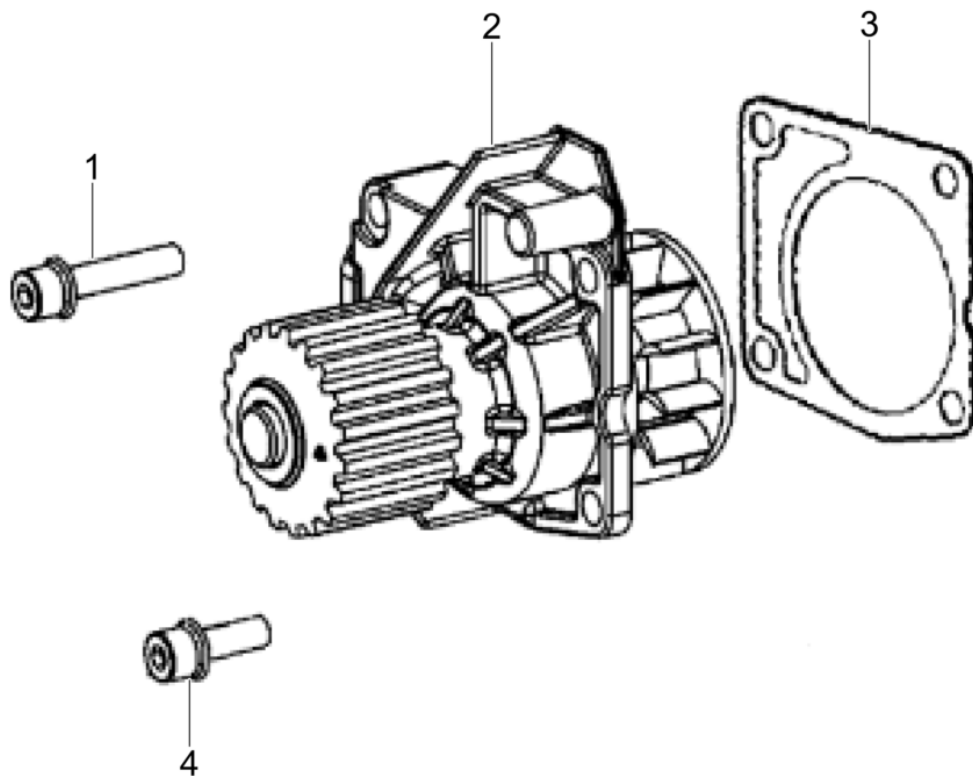

5100042378_01

Pos. Item	Artikel Nr. Item no.	Pc.	Unit	Beschreibung Descripción	Description Description	Abm. Dim.	Norm Standard
						Drehmoment Torque	Schmierstoff Lubricant
1	5000209105	2	pc	Sechskantschraube Tornillo hexagonal	Hexagonal head cap screw Vis à tête hexagonale		
2	5100042311	1	pc	Wasserpumpe Kpl. Bomba del agua compl.	Water pump cpl. Pompe à eau compl.		
3	5000159298	1	pc	Dichtung Junta	Gasket Joint		
4	5200009523	2	pc	Innensechskantschraube Perno	Bolt Boulon	M8	

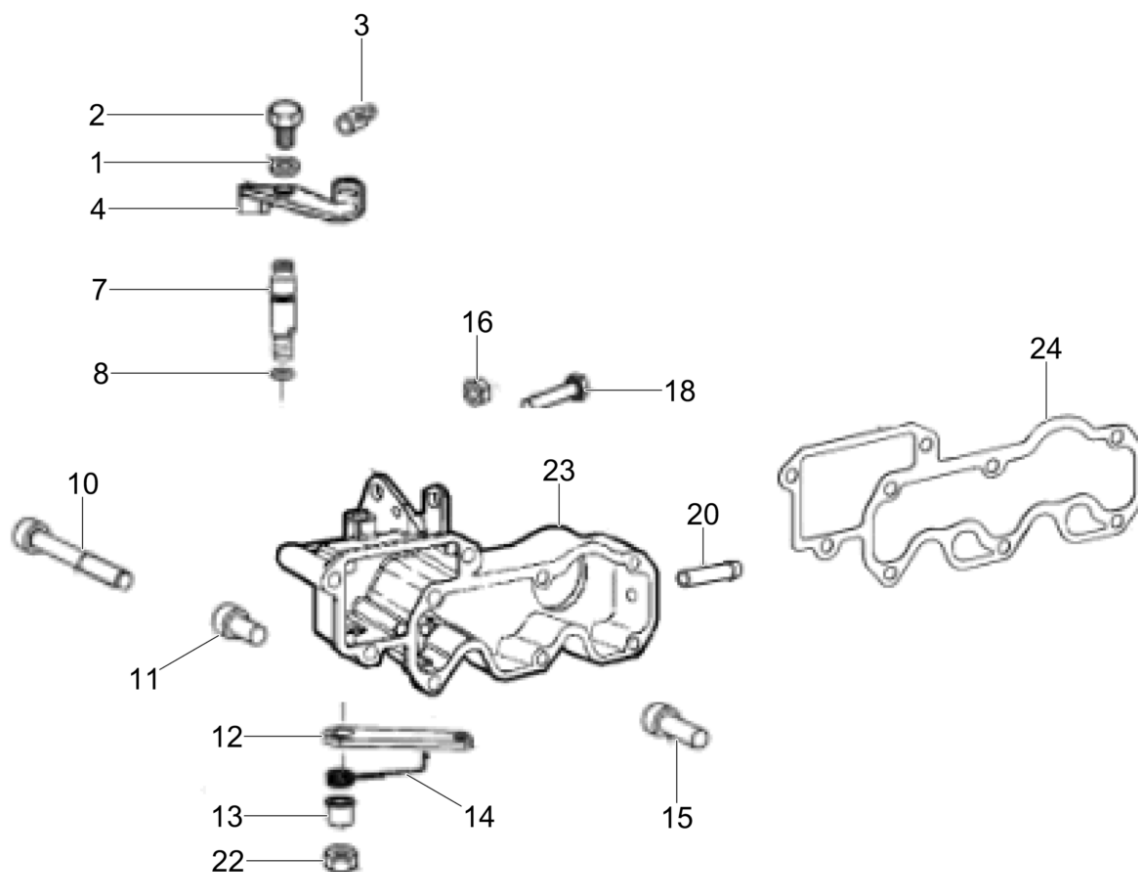

5100042379_01

Pos. Item	Artikel Nr. Item no.	Pc.	Unit	Beschreibung Descripción	Description Description	Abm. Dim.	Norm Standard
						Drehmoment Torque	Schmierstoff Lubricant
1	5200009524	1	pc	Scheibe Arandela	Washer Rondelle		
2	5200009525	1	pc	Bolzen Perno	Bolt Boulon	M8	
3	5000203352	1	pc	Klemmstück Pieza de fijación	Clamping piece Pièce de serrage		
4	5000160214	1	pc	Hebel Palanca	Lever Levier		
7	5200009526	1	pc	Gasreglerwelle Pasador de mariposa	Throttle pin Goupille des gaz		
8	5000159230	1	pc	Öldichtung Junta de aceite	Oil seal Joint d'huile		
10	5000084170	1	pc	Schraube Tornillo	Screw Vis		
11	5000159476	3	pc	Schraube Tornillo	Screw Vis		
12	5000215504	1	pc	Hebel Palanca	Lever Levier		
13	5000215481	1	pc	Hülse Collar	Collar Douille		
14	5000215508	1	pc	Feder Resorte	Spring Ressort		
15	5000203346	4	pc	Schraube Tornillo	Screw Vis		
16	5000159272	2	pc	Mutter Tuerca	Nut Écrou		
18	5000206214	2	pc	Schraube Tornillo	Screw Vis	M6 x 30	
20	5000159462	1	pc	Schlauch Manguera	Hose Boyau		
22	5000084232	1	pc	Mutter Tuerca	Nut Ecrou		
23	5000215487	1	pc	Verteiler, Einlass Distribuidor, admisión	Manifold inlet Tubulure, admission		
24	5000160186	1	pc	Ansaugkrümmerdichtung Junta-distribuidor de admisión	Intake manifold gasket Joint-collecteur d'admission		
39	5000084171	1	pc	Schraube Tornillo	Screw Vis		

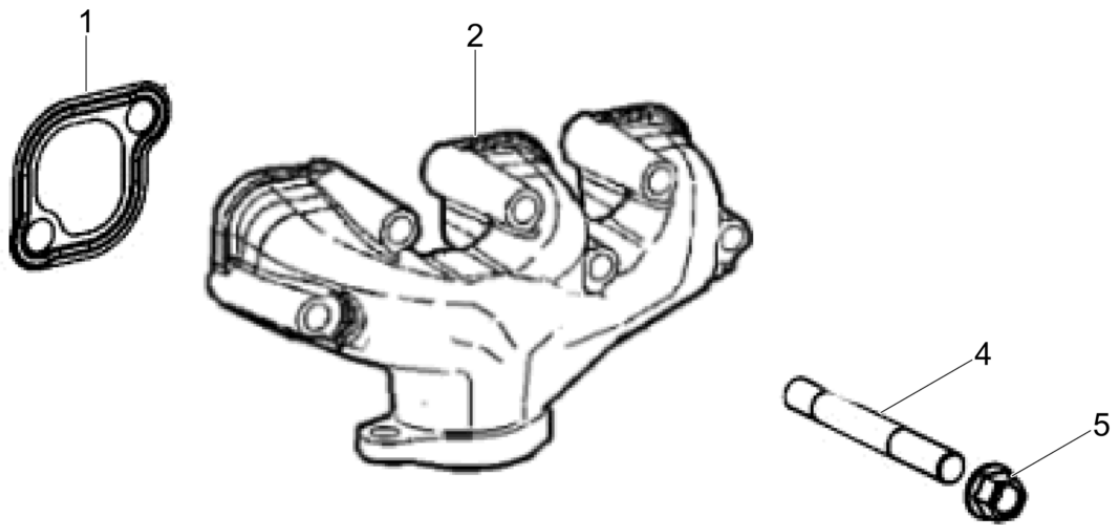

5100042380_01

Pos. Item	Artikel Nr. Item no.	Pc.	Unit	Beschreibung Descripción	Description Description	Abm. Dim.	Norm Standard
						Drehmoment Torque	Schmierstoff Lubricant
1	5000159290	3	pc	Dichtung Junta de estanqueidad	Gasket Garniture		
2	5000159263	1	pc	Auspuffkrümmer Distribuidor de escape	Exhaust manifold Collecteur d'échappement		
4	5000082267	6	pc	Gewindebolzen Perno prisionero	Stud Boulon		
5	5000086331	6	pc	Mutter Tuerca	Nut Écrou		

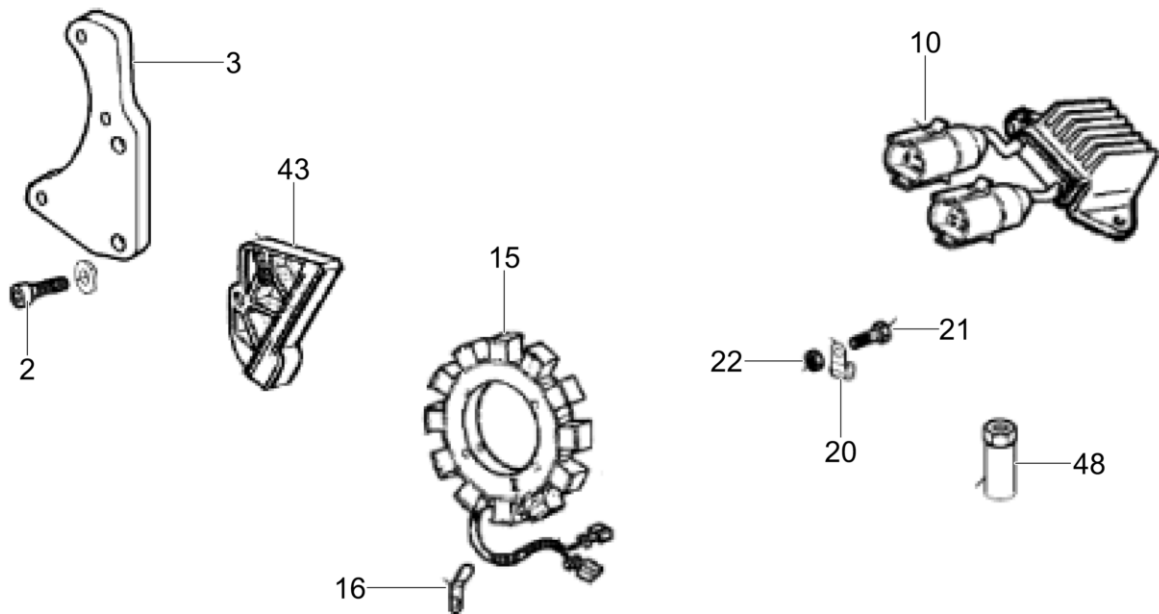

5100042381_01

Pos. Item	Artikel Nr. Item no.	Pc.	Unit	Beschreibung Descripción	Description Description	Abm. Dim.	Norm Standard
						Drehmoment Torque	Schmierstoff Lubricant
2	5000159476	2	pc	Schraube Tornillo	Screw Vis		
3	5200023967	1	pc	Konsole Für Lichtmaschine Soporte para alternador	Alternator support Support pour alternateur		
10	5200000154	1	pc	Spannungsregler Regulador de voltaje	Voltage regulator Régulateur de tension		
15	5000159446	1	pc	Stator Estator	Stator Stator		
16	5200023968	1	pc	Platte Placa	Plate Plaque		
20	5000209002	1	pc	Schelle Abrazadera	Clamp Collier		
21	5000084156	1	pc	Schraube Tornillo	Screw Vis		
22	5000082140	1	pc	Mutter Tuerca	Nut Écrou		
43	5000159283	1	pc	Flansch Brida	Flange Bride		
48	5200000140	2	pc	Mutter Tuerca	Nut Écrou	M8 25Nm/18ft.lbs	

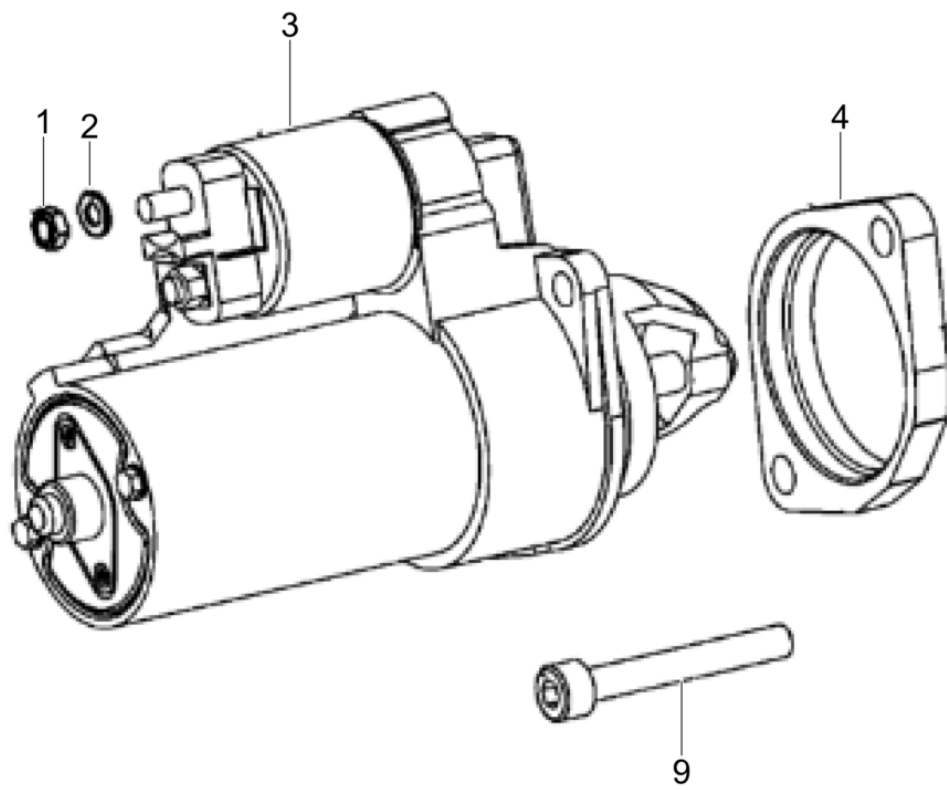

5100042382_01

Pos. Item	Artikel Nr. Item no.	Pc.	Unit	Beschreibung Descripción	Description Description	Abm. Dim.	Norm Standard
						Drehmoment Torque	Schmierstoff Lubricant
1	5000215493	1	pc	Sechskantmutter Tuerca hexagonal	Hexagon nut Écrou hexagonal		
2	5000082288	1	pc	Scheibe Arandela	Washer Rondelle		
3	5000160374	1	pc	Anlasser Motor de arranque	Starter motor Démarreur		
4	5000206968	1	pc	Flansch Brida	Flange Bride		
9	5000083027	2	pc	Schraube Tornillo	Screw Vis		

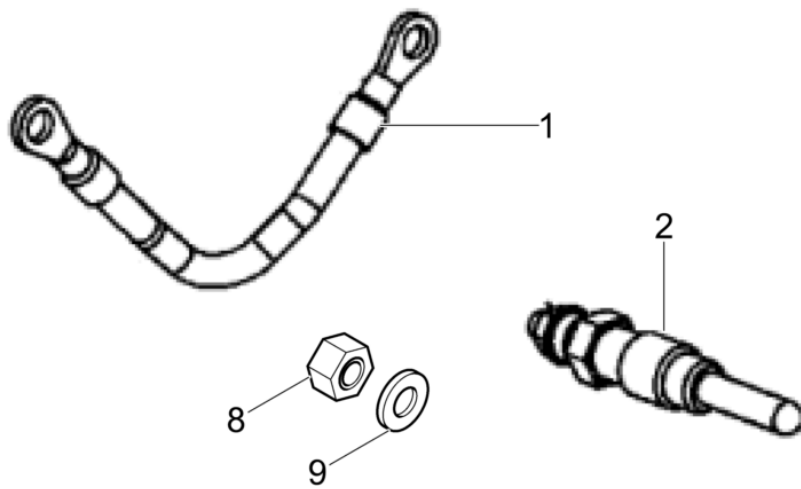

5100042384_01

Pos. Item	Artikel Nr. Item no.	Pc.	Unit	Beschreibung Descripción	Description Description	Abm. Dim.	Norm Standard
						Drehmoment Torque	Schmierstoff Lubricant
1	5000159259	2	pc	Kabel Cable	Cable Câble		
2	5000155748	3	pc	Glühkerze Tapón luminoso	Glow plug Bougie de préchauffage		

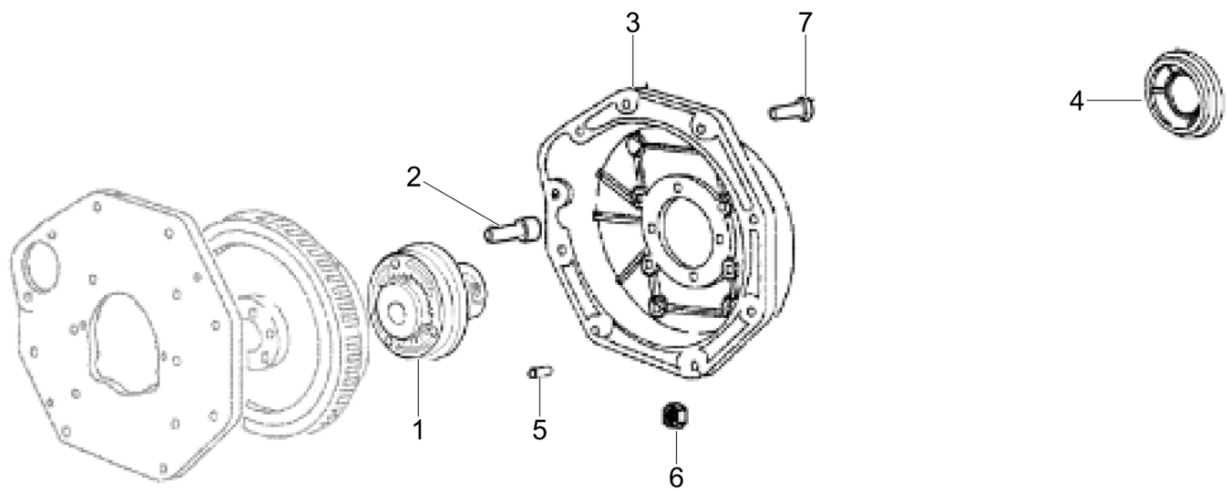

5100042385_01

Pos. Item	Artikel Nr. Item no.	Pc.	Unit	Beschreibung Descripción	Description Description	Abm. Dim.	Norm Standard
						Drehmoment Torque	Schmierstoff Lubricant
1	5000161077	1	pc	Kupplung Acoplamiento	Coupling Accouplement		
2	5000084164	3	pc	Schraube Tornillo	Screw Vis		
3	5000161076	1	pc	Gehäuse Caja	Housing Carter		
4	5000161078	1	pc	Abstandsstück Espaciador	Spacer Entretoise		
5	5000161080	2	pc	Paßstift Espiga	Dowel pin Cheville		
6	5000082140	5	pc	Mutter Tuerca	Nut Écrou		
7	5000084123	7	pc	Schraube Tornillo	Screw Vis		

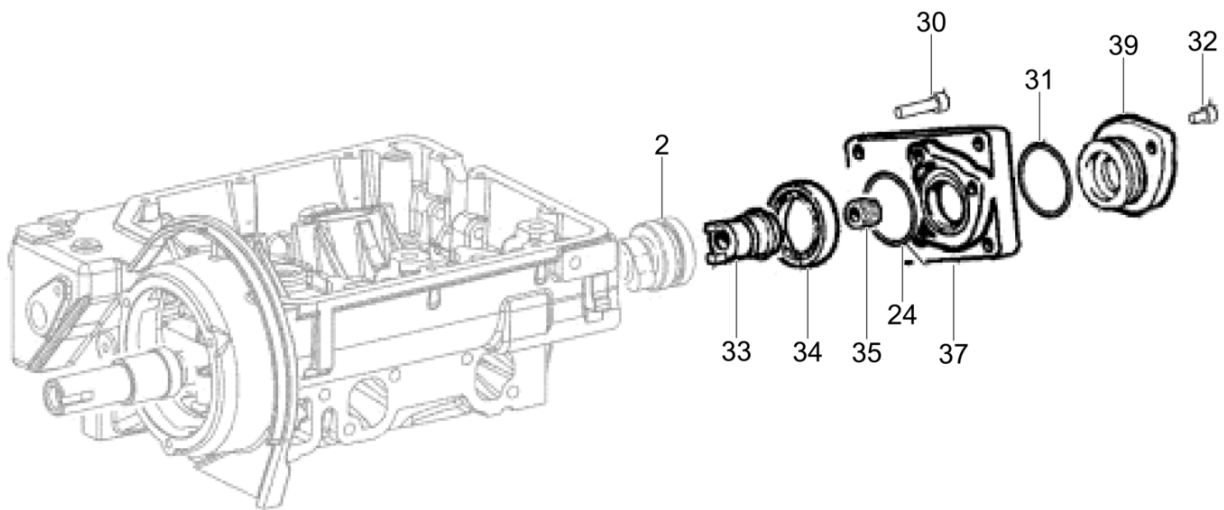

5100042386_01

Pos. Item	Artikel Nr. Item no.	Pc.	Unit	Beschreibung Descripción	Description Description	Abm. Dim.	Norm Standard
						Drehmoment Torque	Schmierstoff Lubricant
2	5000160761	1	pc	O-Ring Anillo-o	O-ring Joint torique	1,42in	
24	5000159234	1	pc	Öldichtung Junta de aceite	Oil seal Joint d'huile		
30	5000160763	3	pc	Bolzen Perno	Bolt Boulon		
31	5000110759	1	pc	Dichtung Junta	Seal Joint		
32	5000160764	2	pc	Bolzen Perno	Bolt Boulon		
33	5000160754	1	pc	Buchse Buje	Bushing Douille		
34	5000160759	1	pc	Kugellager Rodamiento de bolas	Ball bearing Roulement à billes		
35	5000160755	1	pc	Keilnutenkupplung Acoplamiento de chaveta y ranura	Spline coupling Accouplement cannelé		
37	5000160758	1	pc	Flansch Brida	Flange Collerette		
39	5100042313	1	pc	Flansch Brida	Flange Collerette		

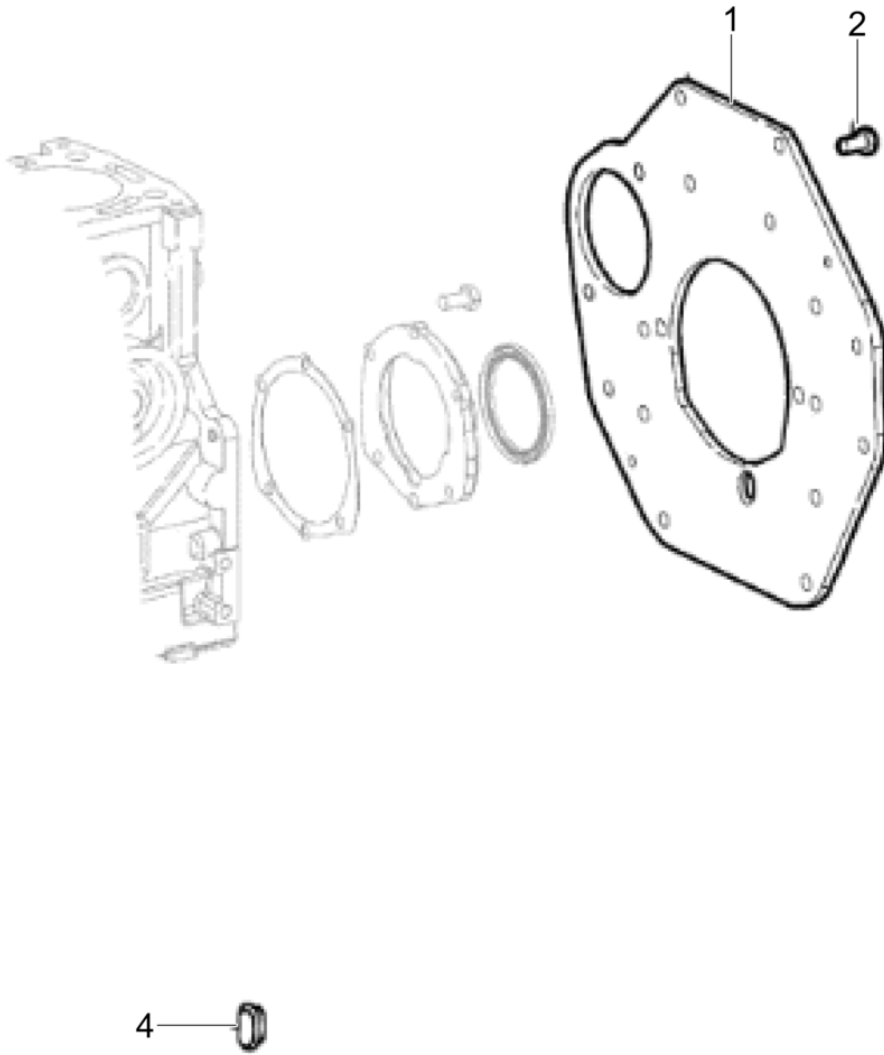

5100042387_01

Pos. Item	Artikel Nr. Item no.	Pc.	Unit	Beschreibung Descripción	Description Description	Abm. Dim.	Norm Standard
						Drehmoment Torque	Schmierstoff Lubricant
1	5000159326	1	pc	Platte Placa	Plate Plaque		
2	5000159254	9	pc	Bolzen Perno	Bolt Boulon		
4	5200009534	1	pc	Stopfen Tapón	Plug Bouchon		

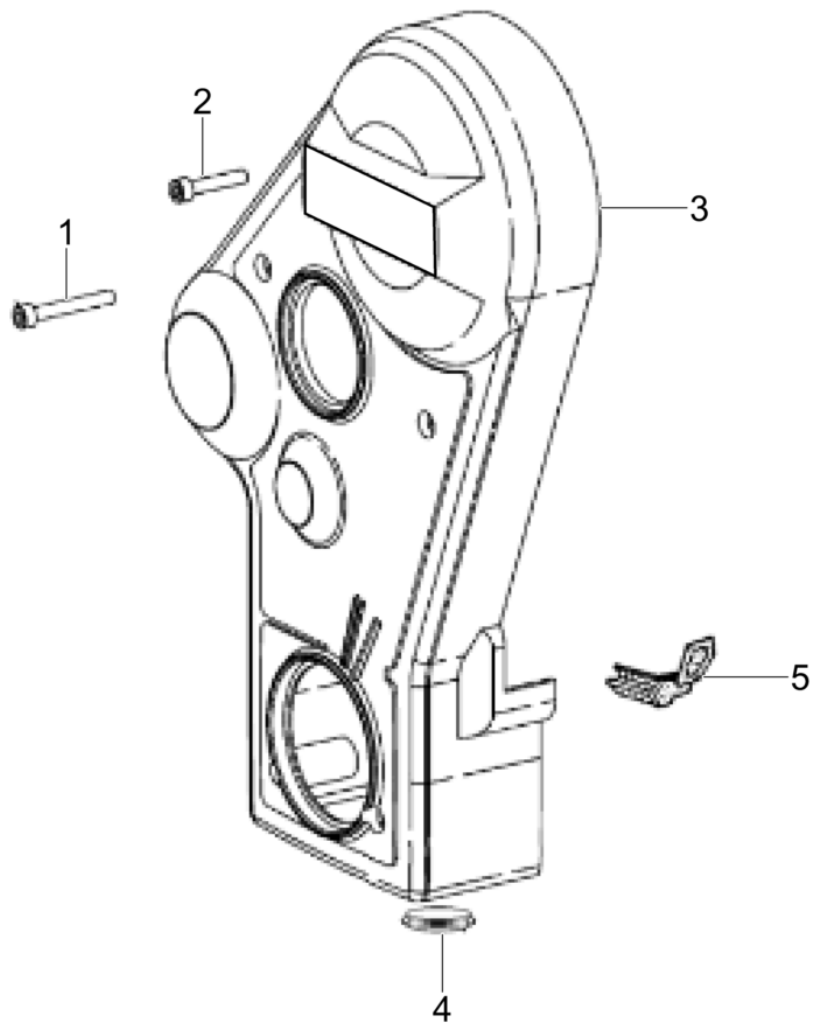

5100042388_01

Pos. Item	Artikel Nr. Item no.	Pc.	Unit	Beschreibung Descripción	Description Description	Abm. Dim.	Norm Standard
						Drehmoment Torque	Schmierstoff Lubricant
1	5000159564	1	pc	Schraube Tornillo	Screw Vis		
2	5000159475	4	pc	Schraube Tornillo	Screw Vis		
3	5000159335	1	pc	Riemenschutz Guardacorrea	Beltguard Protection de courroie		
4	5000159268	1	pc	Stopfen Enchufe	Plug Prise		
5	5000215499	1	pc	Dichtung Junta de estanqueidad	Gasket Garniture		

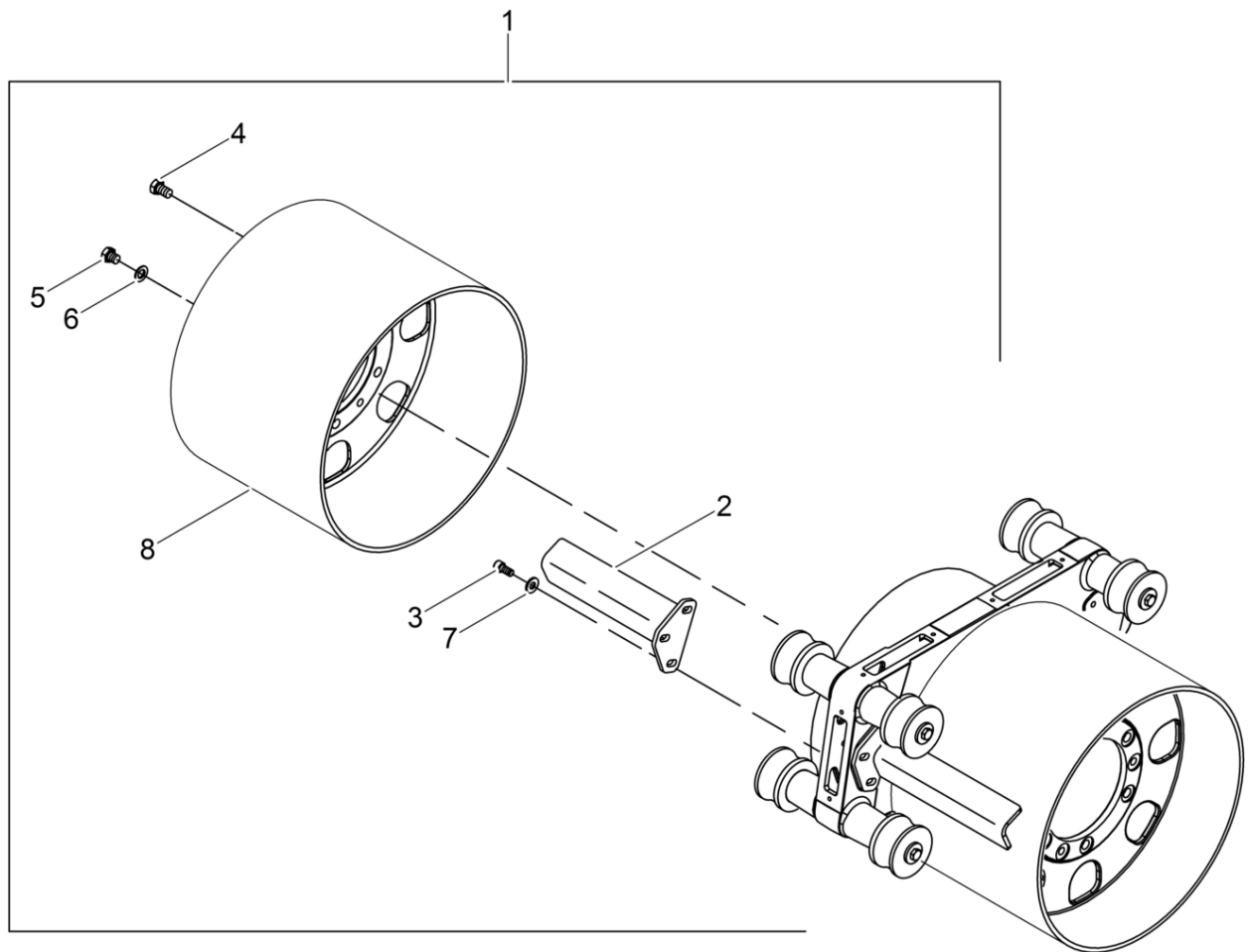

wc_ex0162787001

Pos. Item	Artikel Nr. Item no.	Pc.	Unit	Beschreibung Descripción	Description Description	Abm. Dim.	Norm Standard
						Drehmoment Torque	Schmierstoff Lubricant
1	5000162787	1	pc	Bandagensatz Juego de tambor (plano)	Smooth drum kit Jeu de tambour (lisse)	820mm/32in	
2	5200006892	8	pc	Bandage-Abstreifer Barra raspadora-ancho	Wide scraper Racleur large		
3	5000017087	24	pc	Zylinderschraube Tornillo cilíndrico	Socket head cap screw Vis à tête cylindrique	M12 x 30 86Nm/63ft.lbs	ISO4762
4	5000011542	24	pc	Zylinderschraube Tornillo cilíndrico	Cheese head screw Vis à tête cylindrique	202Nm/149ft.lbs	
5	5000031826	12	pc	Sechskantschraube Tornillo hexagonal	Hexagonal head cap screw Vis à tête hexagonale	M16 x 16 202Nm/149ft.lbs	
6	5000010618	24	pc	Scheibe Arandela	Flat washer Rondelle	16	ISO7090
7	5000031565	24	pc	Spannscheibe Arandela elástica	Lockwasher Rondelle de ressort	12	DIN6796
8	5000171665	4	pc	Bandage (Glatt) Tambor (plano)	Smooth drum Tambour (lisse)	820	

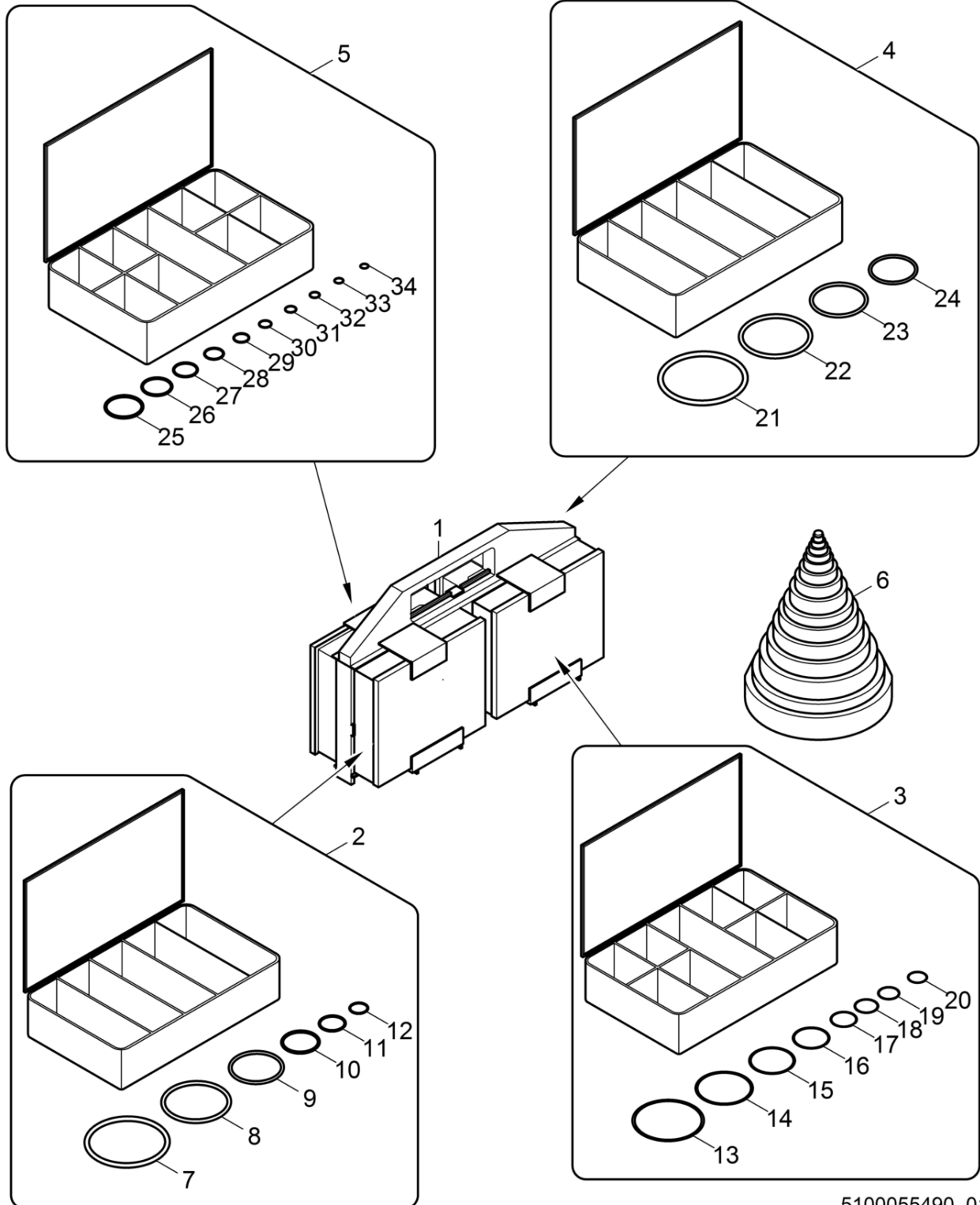

5100055490_01

Pos. Item	Artikel Nr. Item no.	Pc.	Unit	Beschreibung Descripción	Description Description	Abm. Dim.	Norm Standard
						Drehmoment Torque	Schmierstoff Lubricant
1	5100041560	1	pc	O-Ringsatz Kpl. Juego de anillo-o compl.	O-ring kit cpl. Jue de joint torique compl.		
2	5100041338	1	pc	O-Ringsatz Juego de anillo-o	O-ring kit Jue de joint torique		
3	5100041535	1	pc	O-Ringsatz Juego de anillo-o	O-ring kit Jue de joint torique		
4	5100041544	1	pc	O-Ringsatz Juego de anillo-o	O-ring kit Jue de joint torique		
5	5100041549	1	pc	O-Ringsatz Juego de anillo-o	O-ring kit Jue de joint torique		
6	5100041559	1	pc	Konusstück Cono	Sizing cone Cône		
7	5100041339	1	pc	O-Ring Anillo-o	O-ring Joint torique	8	
8	5100041530	1	pc	O-Ring Anillo-o	O-ring Joint torique	12	
9	5100041531	1	pc	O-Ring Anillo-o	O-ring Joint torique	16	
10	5100041532	1	pc	O-Ring Anillo-o	O-ring Joint torique	20	
11	5100041533	1	pc	O-Ring Anillo-o	O-ring Joint torique	24	
12	5100041534	1	pc	O-Ring Anillo-o	O-ring Joint torique	32	
13	5100041536	1	pc	O-Ring Anillo-o	O-ring Joint torique	4	
14	5100041537	1	pc	O-Ring Anillo-o	O-ring Joint torique	6	
15	5100041538	1	pc	O-Ring Anillo-o	O-ring Joint torique	8	
16	5100041539	1	pc	O-Ring Anillo-o	O-ring Joint torique	10	
17	5100041540	1	pc	O-Ring Anillo-o	O-ring Joint torique	12	
18	5100041541	1	pc	O-Ring Anillo-o	O-ring Joint torique	16	
19	5100041542	1	pc	O-Ring Anillo-o	O-ring Joint torique	20	
20	5100041543	1	pc	O-Ring Anillo-o	O-ring Joint torique	24	
21	5100041545	1	pc	O-Ring Anillo-o	O-ring Joint torique	16	
22	5100041546	1	pc	O-Ring Anillo-o	O-ring Joint torique	20	
23	5100041547	1	pc	O-Ring Anillo-o	O-ring Joint torique	24	
24	5100041548	1	pc	O-Ring Anillo-o	O-ring Joint torique	32	
25	5100041550	1	pc	O-Ring Anillo-o	O-ring Joint torique	2	
26	5100041551	1	pc	O-Ring Anillo-o	O-ring Joint torique	3	
27	5100041552	1	pc	O-Ring Anillo-o	O-ring Joint torique	4	
28	5100041553	1	pc	O-Ring Anillo-o	O-ring Joint torique	5	



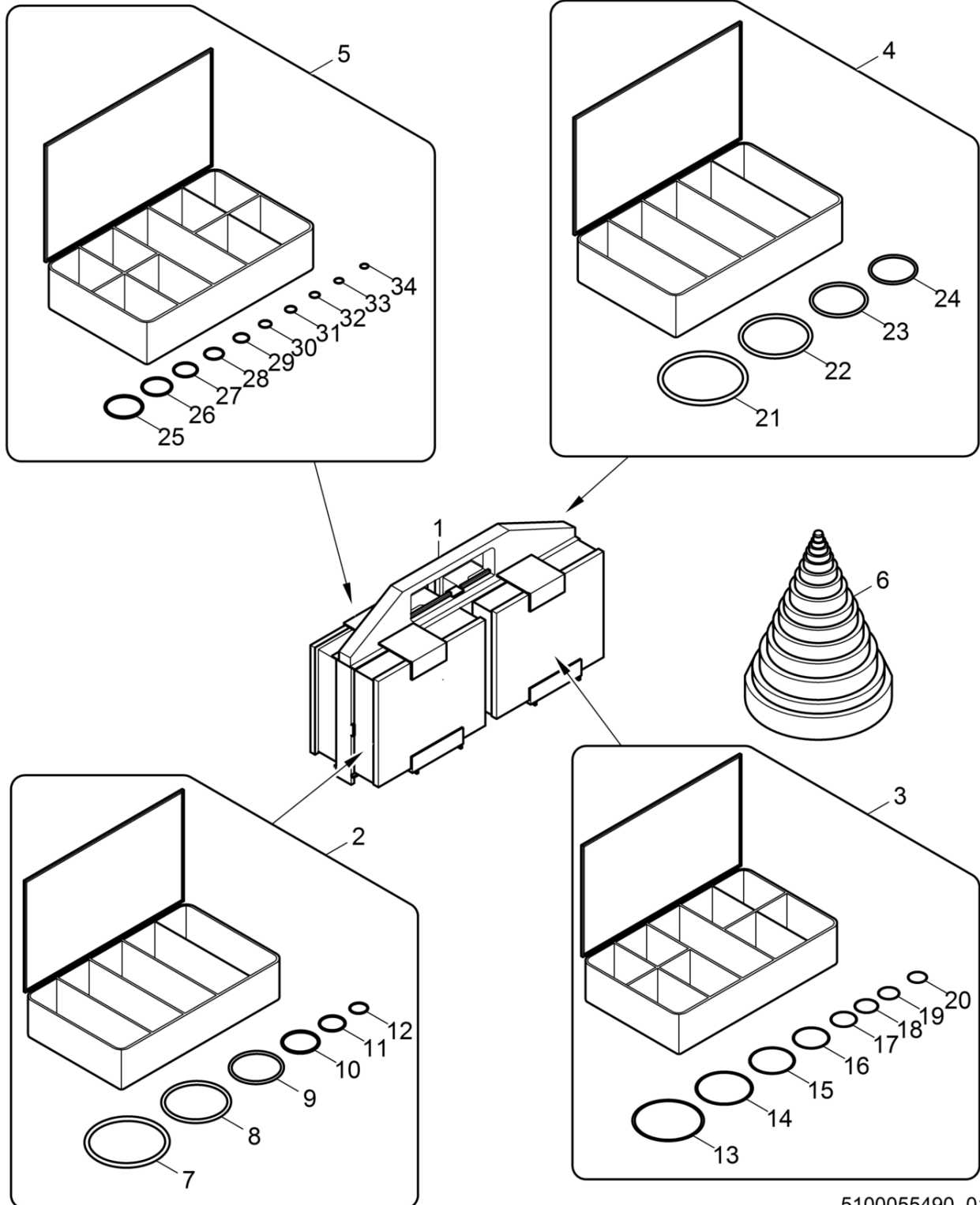

5100055490_01

Pos. Item	Artikel Nr. Item no.	Pc.	Unit	Beschreibung Descripción	Description Description	Abm. Dim.	Norm Standard
						Drehmoment Torque	Schmierstoff Lubricant
29	5100041554	1	pc	O-Ring Anillo-o	O-ring Joint torique	6	
30	5100041555	1	pc	O-Ring Anillo-o	O-ring Joint torique	8	
31	5100041556	1	pc	O-Ring Anillo-o	O-ring Joint torique	10	
32	5100041557	1	pc	O-Ring Anillo-o	O-ring Joint torique	12	
33	5100041558	1	pc	O-Ring Anillo-o	O-ring Joint torique	14	



**WACKER
NEUSON**

