



**WACKER
NEUSON**

Ersatzteilkatalog
Spare parts list
Catalogo de piezas de repuesto
Catalogue des pièces détachées

**Walze
Roller
Rodillos
Rouleaux**

RTKx-SC3



Type	RTKx-SC3
Material Number	5100052337
Version	101
Language	de en es fr



www.wackerneuson.com

Copyright © 02.2020
Wacker Neuson Production Americas LLC
Printed in USA.
All rights reserved.

Ein Typenschild mit Typ, Artikelnummer, Version und Maschinen-Nummer ist an jedem Gerät angebracht. Die Daten von diesem Schild bitte notieren, damit sie auch bei Verlust oder Beschädigung des Schildes noch vorhanden sind. Der Typ, die Artikelnummer, die Versions-Nummer und die Maschinen-Nummer sind bei der Ersatzteilbestellung oder Nachfragen bezüglich Service-Informationen stets erforderlich.

Bei den in den Ersatzteillisten fettgedruckten Nummern handelt es sich um empfohlene Ersatzteile. Dies bedeutet, daß diese Teile bei normalen Anwendungsbedingungen natürlicher Abnutzung ausgesetzt sind und gelegentlich ersetzt oder überarbeitet werden müssen. Es wird geraten, diese Teile auf Lager bereit zu haben, um für Service-Arbeiten an diesem Gerät vorbereitet zu sein. Lagerbestände für diese und andere Teile, welche für ausgiebigere Reparaturarbeiten benötigt werden, können je nach Service-Gewohnheiten der einzelnen Kunden variieren.

Die Nummern meines Gerätes sind:



1. Typ
2. Version
3. Artikel-Nr.
4. Maschinen-Nr.

Umrechnungstabelle

Volumeneinheit	
1 ml	0.034 US fl.oz.
1 l	0.260 gal
Längeneinheit	
1 mm	0.039 in
1 m	3.280 ft
Gewicht	
1 kg	2.200 lbs
1 g	0.035 oz
Geschwindigkeit	
1 km/h	0.620 mph
Drehmoment	
1 Nm	0.740 ft.lbs

A nameplate listing the Model Number, Item Number, Revision, and Serial Number is attached to each unit. Please record the information found on this plate so it will be available should the nameplate become lost or damaged. When ordering parts or requesting service information, you will always be asked to specify the model, item number, revision number, and serial number of the unit.

Part Numbers appearing in boldface type are recommended spare parts. This means that these parts are subject to wear under normal operating conditions and may require periodic service or replacement. It is recommended that these items be stocked to meet the expected service requirements of this model. Actual stocking quantities of these and other parts used in more extensive repairs will depend on the service practices of each customer.

My machine's numbers are:



1. Model
2. Revision
3. Item No.
4. Serial No.

Conversion table

Volume unit	
1 ml	0.034 US fl.oz.
1 l	0.260 gal
Unit of length	
1 mm	0.039 in
1 m	3.280 ft
Weight	
1 kg	2.200 lbs
1 g	0.035 oz
Speed	
1 km/h	0.620 mph
Torque	
1 Nm	0.740 ft.lbs

Una placa de identificación con el modelo, número de referencia, nivel de revisión y número de serie ha sido añadida en cada máquina. Favor de anotar los datos en la placa en caso de que la placa de identificación sea destruida o perdida. En todos los pedidos para repuestos necesita siempre el modelo, el número de referencia, el nivel de revisión y el número de serie de la máquina en cuestión.

Los números de partes en negritas en las Listas Ilustradas de Partes son los repuestos recomendados, esto quiere decir que estas partes se desgastarán bajo circunstancias de funcionamiento normales y pueden requerir servicio periódico o su reemplazo. Se recomienda que el cliente mantenga un abastecimiento adecuado de estas partes para poder satisfacer la demanda requerida por el servicio a la máquina. La cantidad de repuestos que el cliente necesitará para reparaciones dependerá de la póliza de servicio de cada cliente.

Los números de mi máquina son:

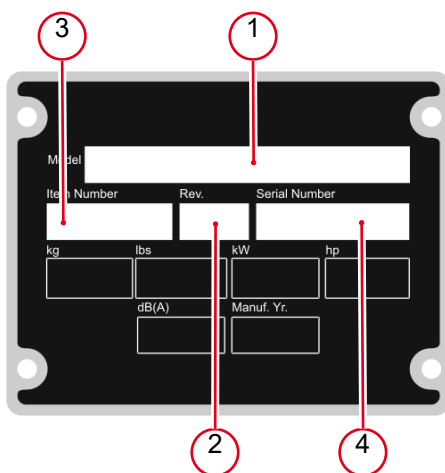

1. Modelo
2. Nivel de revisión
3. Número de referencia
4. Número de Serie

Tabla de conversión

Unidad de volumen	
1 ml	0.034 US fl.oz.
1 l	0.260 gal
Unidad de longitud	
1 mm	0.039 in
1 m	3.280 ft
Peso	
1 kg	2.200 lbs
1 g	0.035 oz
Velocidad	
1 km/h	0.620 mph
Par de apriete	
1 Nm	0.740 ft.lbs

Une plaque signalétique mentionnant le modèle, le numéro de référence, le niveau de revision et le numéro de série est fixée sur chaque machine. Veuillez noter les informations relevées sur cette plaque de façon à ce qu'elles soient toujours disponibles si la plaque signalétique venait à être perdue ou endommagée. Lorsque vous commandez des pièces détachées ou vous sollicitez des informations après-vente, on vous demandera toujours de préciser le modèle, le numéro de référence, le niveau de revision et le numéro de série de la machine.

Les numéros de pièces imprimés en caractères gras dans les Listes des Pièces Détachées de ce manuel sont les pièces détachées recommandées par la Wacker. Cela veut dire que ces pièces sont sujettes à usure dans des conditions de travail normales et peuvent nécessiter de l'entretien ou leur remplacement. Nous recommandons que vous disposez d'un stock de ces pièces pour pouvoir satisfaire la demande d'entretien de cette machine. Le client doit décider lui-même de la quantité exacte de pièces de rechange qu'il disposera dans ses stocks.

Les numéros de ma machine son :



1. Typ
2. Version
3. Artikel-Nr.
4. Maschinen-Nr.

Table de conversion

Unité de volume	
1 ml	0.034 US fl.oz.
1 l	0.260 gal
Unité de longueur	
1 mm	0.039 in
1 m	3.280 ft
Poids	
1 kg	2.200 lbs
1 g	0.035 oz
Vitesse	
1 km/h	0.620 mph
Couple de serrage	
1 Nm	0.740 ft.lbs

Motorkasten Engine compartment Caja de motor Boîte de moteur	10
Vorderrahmen Front frame Bastidor delantero Châssis avant	16
Knickgelenk Articulated steering joint Unión articulada de dirección Joint articulé	20
Armaturen/Leitungen Electric equipment/wiring Equipo eléctrico/cables Équipement électrique/câblage	22
Hydraulik-Rohrleitung Hydraulic piping Tubería hidráulica Canalisation hydraulique	26
Hydraulik-Rohrleitung-2 Hydraulic piping-2 Tubería hidráulica-2 Canalisation hydraulique-2	28
Hinterrahmen Rear frame Bastidor de atrás Châssis arrière	32
Vorderdeckel Front cover Tapa delantera Couvercle avant	36
Steuerkontrolle Rear section/controls Sección posterior/palanca de mando Partie arrière/guidons	38
Hinterdeckel Rear cover Tapa de atrás Couvercle arrière	42
Bandagenantrieb Drum drive Accionamiento de tambor Entraînement de tambour	44
Bandagenantrieb Mit Bremse Drum drive w/brake Accionamiento de tambor con freno Entraînement de tambour avec f	48

Vorderbandage Front drum Tambor delantero Tambour avant	54
--	----

Hinterbandage Rear drum Tambor de atrás Tambour arrière	56
--	----

Erreger Kpl. Exciter cpl. Excitador compl. Excitatrice compl.	58
---	----

Hydraulikverteiler Hydraulic manifold Distribuidor hidráulico Tubulure hydraulique	60
---	----

Hydrauliktank Hydraulic tank Tanque hidráulico Réservoir hydraulique	64
---	----

Sender Transmitter module Transmisor Transmetteur	66
--	----

Motor-Ersatzteile Engine service parts Repuestos de motor Pièces détachées du moteur	68
---	----

Aufkleber Labels Calcomanias Autocollants	70
--	----

Sonderzubehör
Accessories
Accesorios
Accessoires

Bandagensatz (glatt) Smooth drum kit Juego de tambor (plano) Jeu de tambour (lisse)	72
--	----



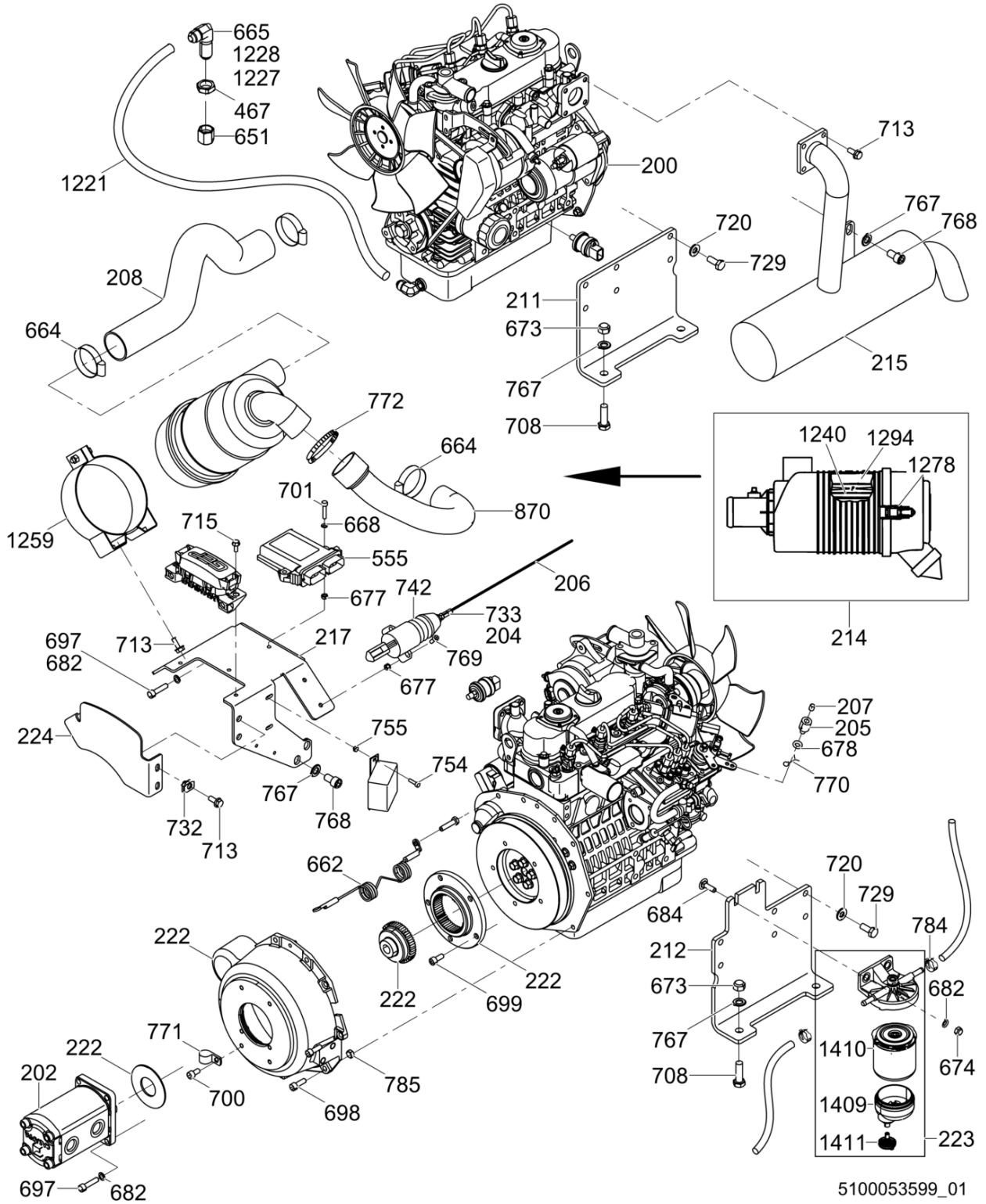

5100053599_01

Pos. Ref.	Artikel Nr. Part No.	Qty.	Unit	Beschreibung Description	Description Description	Abm. Measur.	Norm Standard
						Drehm. Torque	Schmierstoff Sealant
200	5100051390	1	pc	Kubota-Motor Motor kubota	Engine-kubota Moteur kubota		
202	5200015686	1	pc	Erreger/Antriebs Pumpe Bomba del excitador/ accionamiento	Exciter/drive pump Pompe de l'excitatrice/d'entra		
204	5000155487	1	pc	Adapter Adaptador	Adaptor Adaptateur		
205	5200017277	1	pc	Hülse Manguito	Sleeve Douille		
206	5200017278	1	pc	Bowdenzug Cable del acelerador	Throttle cable Câble des gaz		
207	5000156315	1	pc	Gewindestift Tornillo	Setscrew Vis	M6 x 10	
208	5200015684	1	pc	Druckluftschlauch Manguera de aire	Air hose Tuyau à air		
211	5200016458	1	pc	Zylinderkonsole Soporte del motor	Engine bracket Support de culasse		
212	5200016459	1	pc	Motorhalterung Soporte del motor	Engine bracket Support de culasse		
214	5000176114	1	pc	Luftfilter Filtro del aire	Air cleaner Boîtier de filtre complet		
215	5200015413	1	pc	Auspufftopf Silenciador	Muffler Pot d'échappement		
217	5200017659	1	pc	Konsole Soporte	Bracket Support		
222	5200015702	1	pc	Kupplung Kpl. Acoplamiento compl.	Coupling cpl. Accouplement compl.		
223	5200018397	1	pc	Kraftstofffilter Mit Wasserabschei- Der Filtro de combustible con dispositivo para separar	Fuel filter w/water separator Filtre de carburant avec purge		
224	5200019619	1	pc	Deckel Tapa	Cover Couvercle		
467	5000160579	1	pc	Mutter Tuerca	Nut Écrou	No.8 x 3/4-16	
555	5200025081	1	pc	Motorkontrollmodul Módulo de mando del motor	Engine control module Module de contrôle de moteur		
651	5000119929	1	pc	Verschraubung, Kappe Unión, tapa	Fitting cap Raccord, capuchon	No.8	
662	5200017605	1	pc	Trageschleife Cordón	Lanyard Cordon		
664	5000119938	3	pc	Schlauchschelle Abrazaderas de manguera	Hose clamp Agrafe de tuyau	No.32	
665	5000119960	1	pc	Verschraubung Unión	Fitting Raccord	No.8	
673	5000010366	4	pc	Sechskantmutter Tuerca hexagonal	Hexagon nut Écrou hexagonal	M12X1.75	
674	5000010367	2	pc	Sechskantmutter Tuerca hexagonal	Hexagon nut Écrou hexagonal	M8	
677	5000010368	4	pc	Sechskantmutter Tuerca hexagonal	Hexagon nut Écrou hexagonal	M6	DIN985
678	5000010624	1	pc	Scheibe Arandela	Flat washer Rondelle		
682	5000010622	8	pc	Scheibe Arandela	Flat washer Rondelle		
684	5000011151	2	pc	Schloßschraube Tornillo de carruaje	Carriage bolt Boulon brut à tête bombée	M8 x 30	DIN603

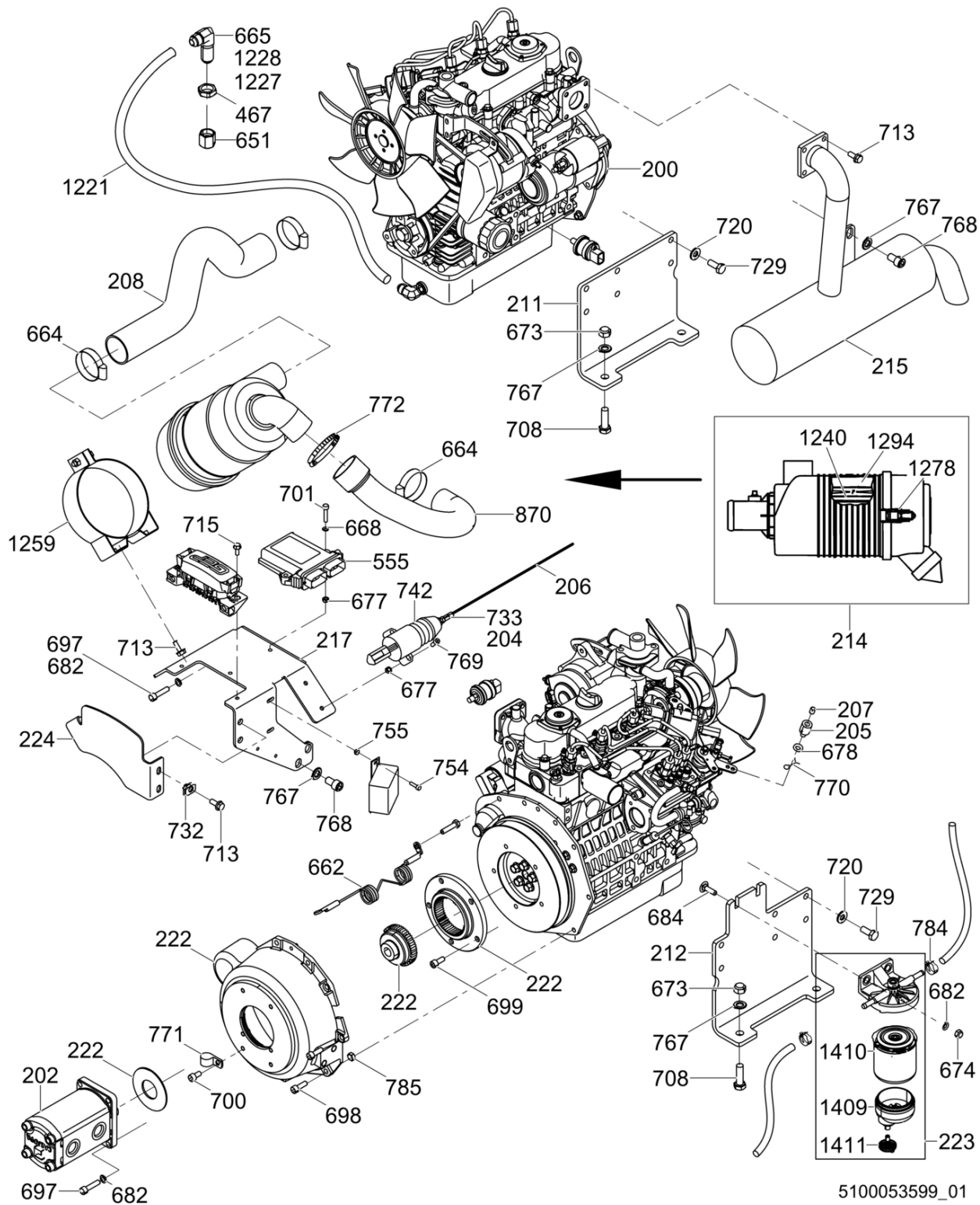

5100053599_01

Pos. Ref.	Artikel Nr. Part No.	Qty.	Unit	Beschreibung Description	Description Description	Abm. Measur.	Norm Standard
						Drehm. Torque	Schmierstoff Sealant
688	5000117969	2	pc	Sechskantschraube Tornillo hexagonal	Hexagonal head cap screw Boulon à tête hexagonale	M8 x 45 25Nm/18ft.lbs	
697	5000157151	6	pc	Zylinderschraube Tornillo cilíndrico	Socket head cap screw Vis à tête cylindrique	M8 x 35	
698	5000011542	8	pc	Zylinderschraube Tornillo cilíndrico	Cheese head screw Vis à tête cylindrique	25Nm/18ft.lbs	
699	5000011543	5	pc	Zylinderschraube Tornillo hueco	Socket head screw Vis à six-pans creux	M8 x 20 24Nm/18ft.lbs	ISO4762
700	5000157154	2	pc	Sechskant-Schraube Tornillo hueco	Screw-socket head Vis à six-pans creux	M8 x 16	
701	5000011549	2	pc	Zylinderschraube Tornillo cilíndrico	Cheese head screw Vis à tête cylindrique	M6 x 30 10Nm/7ft.lbs	ISO4762
708	5000016434	4	pc	Schraube Tornillo	Screw Vis	M12 x 40 120Nm/89ft.lbs	
713	5000028404	8	pc	Schraube Tornillo	Screw Vis	M8 x 20 25Nm/18ft.lbs	
715	5000028949	2	pc	Schraube Tornillo	Screw Vis	M6 x 16 10Nm/7ft.lbs	
720	5000033988	12	pc	Spannscheibe Arandela elástica	Lockwasher Rondelle de ressort	10	DIN6796
729	5000011440	12	pc	Sechskantschraube Tornillo hexagonal	Hexagonal head cap screw Vis à tête hexagonale	M10 x 25 49Nm/36ft.lbs	DIN933
732	5000110969	3	pc	Klemmutter Sujetador	Clip nut Agrafe	M8	
733	5000010880	1	pc	Sechskantmutter Tuerca hexagonal	Hexagon nut Écrou hexagonal		
742	5000155486	1	pc	Gasreglerstellteil Actuador de acelerador	Throttle actuator Dispositif de commande des gaz		
754	5000011570	2	pc	Zylinderschraube Tornillo cilíndrico	Cheese head screw Vis à tête cylindrique		
755	5000010370	2	pc	Sechskantmutter Tuerca hexagonal	Hexagon nut Écrou hexagonal		
767	5000010620	8	pc	Scheibe Arandela	Flat washer Rondelle	12	ISO7090
768	5000081333	4	pc	Schraube Tornillo	Screw Vis	M12 x 20 145Nm/107ft.lbs	
769	5000011553	2	pc	Zylinderschraube Tornillo cilíndrico	Cheese head screw Vis à tête cylindrique		
770	5000114328	1	pc	Sicherungssplint Clavija hendida	Cotter pin Goupille fendue	1,6 x 16	
771	5000164304	1	pc	Rohrschelle Abrazadera para mangueras	Tube clamp Agrafe pour tuyaux souples	3/4in	
772	5000154344	1	pc	Schelle Abrazadera	Clamp Agrafe		
784	5000028707	4	pc	Schelle Abrazadera	Clamp Agrafe	0,21-0,63	
785	5000010882	7	pc	Sechskantmutter Tuerca hexagonal	Hexagon nut Écrou hexagonal		
870	5200015685	1	pc	Einlasskrümmerschlauch Manguera del distribuidor de admisión	Intake manifold hose Tuyau de collecteur d'admissio		
1221	5000119683	1	pc	Hydraulikschlauch Manguera hidráulica	Hydraulic hose Tuyau hydraulique	380	
1227	5000080737	1	pc	O-Ring Anillo-o	O-ring Joint torique	0,49 x 0,07in #8 ORFS	
1228	5000080732	1	pc	O-Ring Anillo-o	O-ring Joint torique	0,64 x 0,09in #8	

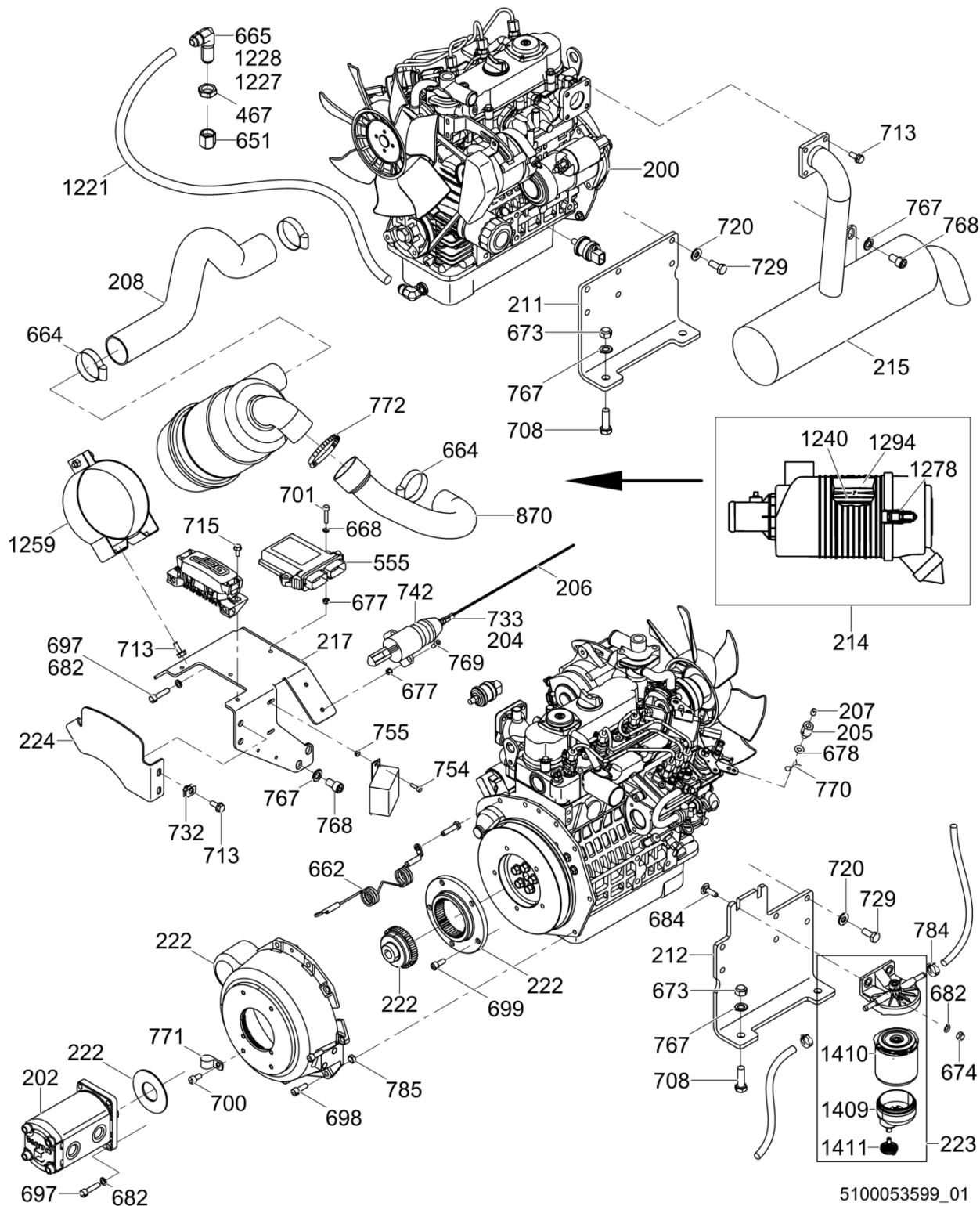

5100053599_01

Pos. Ref.	Artikel Nr. Part No.	Qty.	Unit	Beschreibung Description	Description Description	Abm. Measur.	Norm Standard
						Drehm. Torque	Schmierstoff Sealant
1240	5000160171	1	pc	Filtereinsatz Cartucho filtrante	Filter insert Element filtrant		
1259	5000164069	1	pc	Luftfilterkonsole Soporte de filtro del aire	Air filter bracket Support du filtre à air		
1278	5000171456	1	pc	Klemme Abrazaderaro de aire	Clamp Pince		
1294	5000162184	1	pc	Sekundärelement Elemento secundario	Secondary element Cartouche secondaire		
1409	5200025543	1	pc	Deckel Taza del filtro	Bowl Ecuelle du filtre		
1410	5200025544	1	pc	Filterelement Elemento del filtro	Filter element Élément du filtre		
1411	5200025545	1	pc	Ablaßventil Válvula de vaciado	Drain valve Soupape de drainage		

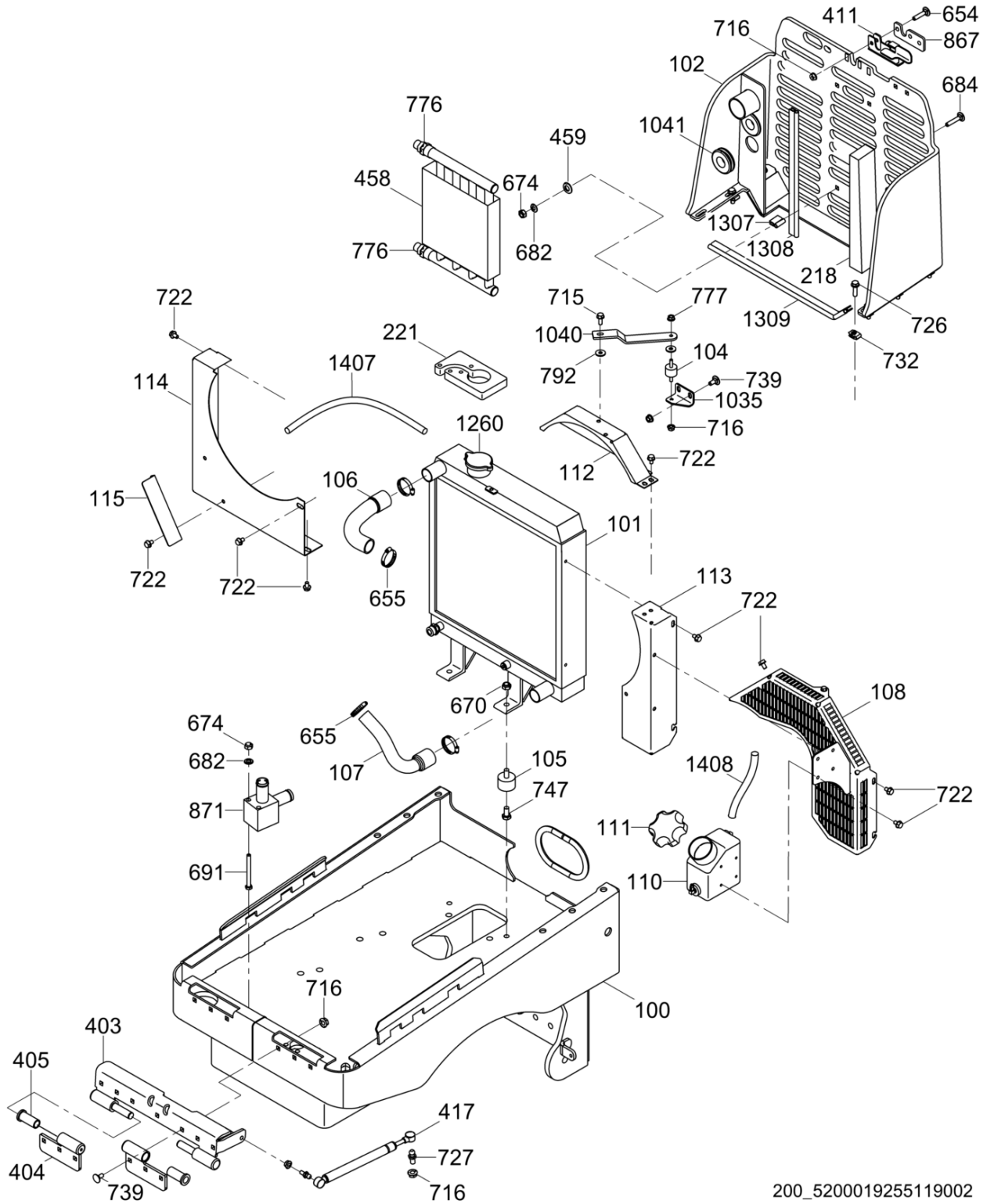

200_5200019255119002

Pos. Ref.	Artikel Nr. Part No.	Qty.	Unit	Beschreibung Descripcion	Description Description	Abm. Measur.	Norm Standard
						Drehm. Torque	Schmierstoff Sealant
100	5000116471	1	pc	Vorderrahmen Chasis delantero	Front frame Châssis avant		
101	5000154348	1	pc	Kühler Radiador	Radiator Radiateur		
102	5000177118	1	pc	Kühlerschutzbügel Guardarradiador	Radiator guard Pare-chocs de radiateur		
104	5000150205	1	pc	Puffer Amortiguador	Shockmount Silentbloc	25 x 19-60 Sh	
105	5000150206	2	pc	Puffer Amortiguador	Shockmount Silentbloc	38,1 x 25,4-60 Sh	
106	5200015682	1	pc	Oberes Kühlerschlauch Manguera superior de radiador	Upper radiator hose Tuyau supérieur de radiateur		
107	5200015683	1	pc	Unteres Kühlerschlauch Manguera inferior de radiador	Lower radiator hose Tuyau de radiateur du bas		
108	5200021560	1	pc	Lüfterhaube Guardaventilador	Fan guard Bague de ventilateur		
110	5000157209	1	pc	Überlaufflasche Botella de rebose	Bottle-overflow Bouteille de trop-plein		
111	5000157255	1	pc	Kappe Tapa	Cap Couvercle		
112	5200015663	1	pc	Gebläsedeckel Tapa de ventilador	Fan cover Couvercle de ventilateur		
112	5200015663	1	pc	Gebläsedeckel Tapa de ventilador	Fan cover Couvercle de ventilateur		
113	5200015665	1	pc	Gebläsedeckel Tapa de ventilador	Fan cover Couvercle de ventilateur		
114	5200015667	1	pc	Gebläsedeckel Tapa de ventilador	Fan cover Couvercle de ventilateur		
115	5200019631	1	pc	Riemenschutz Guardacorrea	Beltguard Protection de courroie		
218	5000150225	1	pc	Dichtung Empaque	Seal Joint		
221	5000150228	1	pc	Dichtung Empaque	Seal Joint		
403	5000119984	1	pc	Stift Pasador	Pin Goupille		
404	5000181474	2	pc	Scharnier Bisagra	Hinge Charnière		
405	5000164540	2	pc	Abstandshülse Espaciador	Bushing spacer Entretoise		
411	5000150098	1	pc	Verriegelung Aldaba	Latch Loquet		
417	5000150104	1	pc	Zylinder Cilindro	Cylinder Cylindre		
458	5200024880	1	pc	Kühler Radiador	Radiator Radiateur		
459	5000045719	4	pc	Scheibe Arandela	Flat washer Rondelle	8,4	DIN7349
652	5000157166	2	pc	Schloßschraube Tornillo de carruaje	Carriage bolt Boulon brut à tête bombée	M8 x 45	
654	5000119954	3	pc	Schloßschraube Tornillo de carruaje	Carriage bolt Boulon brut à tête bombée	M8 x 40	
655	5000119906	4	pc	Schlauchschelle Abrazaderas de manguera	Hose clamp Agrafe de tuyau	No.20 x 0,81 x 1,75in	
670	5000010365	2	pc	Sicherungsmutter Contratuerca	Lock nut Contre-écrou	M10 25Nm/18ft.lbs	DIN 980 V

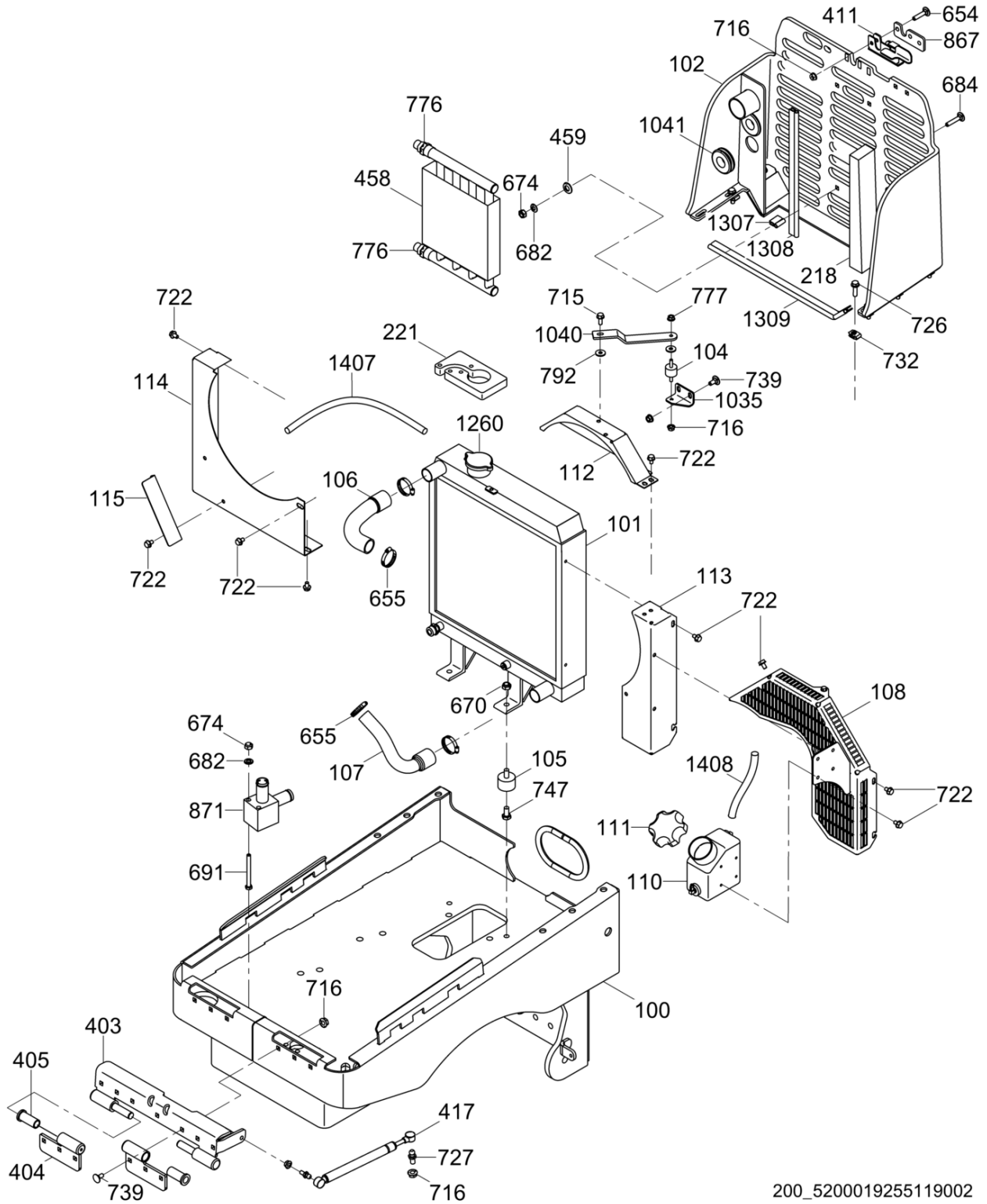

200_5200019255119002

Pos. Ref.	Artikel Nr. Part No.	Qty.	Unit	Beschreibung Description	Description Description	Abm. Measur.	Norm Standard
						Drehm. Torque	Schmierstoff Sealant
674	5000010367	6	pc	Sechskantmutter Tuerca hexagonal	Hexagon nut Écrou hexagonal	M8	
682	5000010622	4	pc	Scheibe Arandela	Flat washer Rondelle		
684	5000011151	4	pc	Schloßschraube Tornillo de carruaje	Carriage bolt Boulon brut à tête bombée	M8 x 30	DIN603
691	5000011310	2	pc	Sechskantschraube Tornillo hexagonal	Hexagonal head cap screw Vis à tête hexagonale	M8 x 85 25Nm/18ft.lbs	DIN931
716	5000030066	13	pc	Sechskantmutter Contratuerca	Locknut Contre-écrou	M8	
722	5000073164	18	pc	Sechskantflanschschraube Tornillo hexagonal de brida	Hexagonal flange head screw Vis hexagonale de bride	M6 x 10 10Nm/7ft.lbs	
726	5000085957	6	pc	Schraube Tornillo	Screw Vis	M8 x 30 25Nm/18ft.lbs	
727	5000155125	1	pc	Gewindebolzen Perno prisionero	Stud Goujon	M8 x 10	
732	5000110969	6	pc	Klemmutter Sujetador	Clip nut Agrafe	M8	
739	5000155841	8	pc	Schloßschraube Tornillo de carruaje	Carriage bolt Boulon brut à tête bombée	M8 x 20	
747	5000157161	2	pc	Sechskantschraube Tornillo hexagonal	Hexagonal head cap screw Boulon à tête hexagonale	M10 x 20	
776	5000081583	2	pc	Verschraubung-Gerade Unión recto	Straight fitting Raccord-droit	No.8	
777	5000029117	1	pc	Sicherungsmutter Contratuerca	Lock nut Contre-écrou	M6	
785	5000010882	2	pc	Sechskantmutter Tuerca hexagonal	Hexagon nut Écrou hexagonal		
792	5000010373	1	pc	Scheibe Arandela	Flat washer Rondelle	6	ISO7093
867	5000160294	1	pc	Abstandsstück Espaciador	Spacer Entretoise		
871	5200017276	1	pc	Verteiler Distribuidor de succión	Suction manifold Collecteur d'aspiration		
1035	5000163899	1	pc	Konsole Soporte	Bracket Support		
1040	5200016530	1	pc	Kühlerträger Soporte del radiador	Radiator bracket Support de radiateur		
1041	5000163464	2	pc	Tülle Ojal	Grommet Passe-fil	1 x 1-3/4 x 1/4in	
1260	5000164350	1	pc	Kühlerverschlußdeckel Tapa del radiador	Radiator cap Couvercle du radiateur		
1307	5000159559	1	pc	Profilgummi Moldura	Seal-trim Garniture	1.0in	
1308	5000159560	1	pc	Profilgummi Moldura	Seal-trim Garniture	17in	
1309	5000159561	1	pc	Profilgummi Moldura	Seal-trim Garniture	1000	
1407	5000114086	1	pc	Kraftstoffleitung Manguera de combustible	Fuel hose Tuyau de carburant	1/4 x 24in	
1408	5000114072	1	pc	Kraftstoffleitung Manguera de combustible	Fuel hose Tuyau de carburant	1-4 x 20-1/2in	

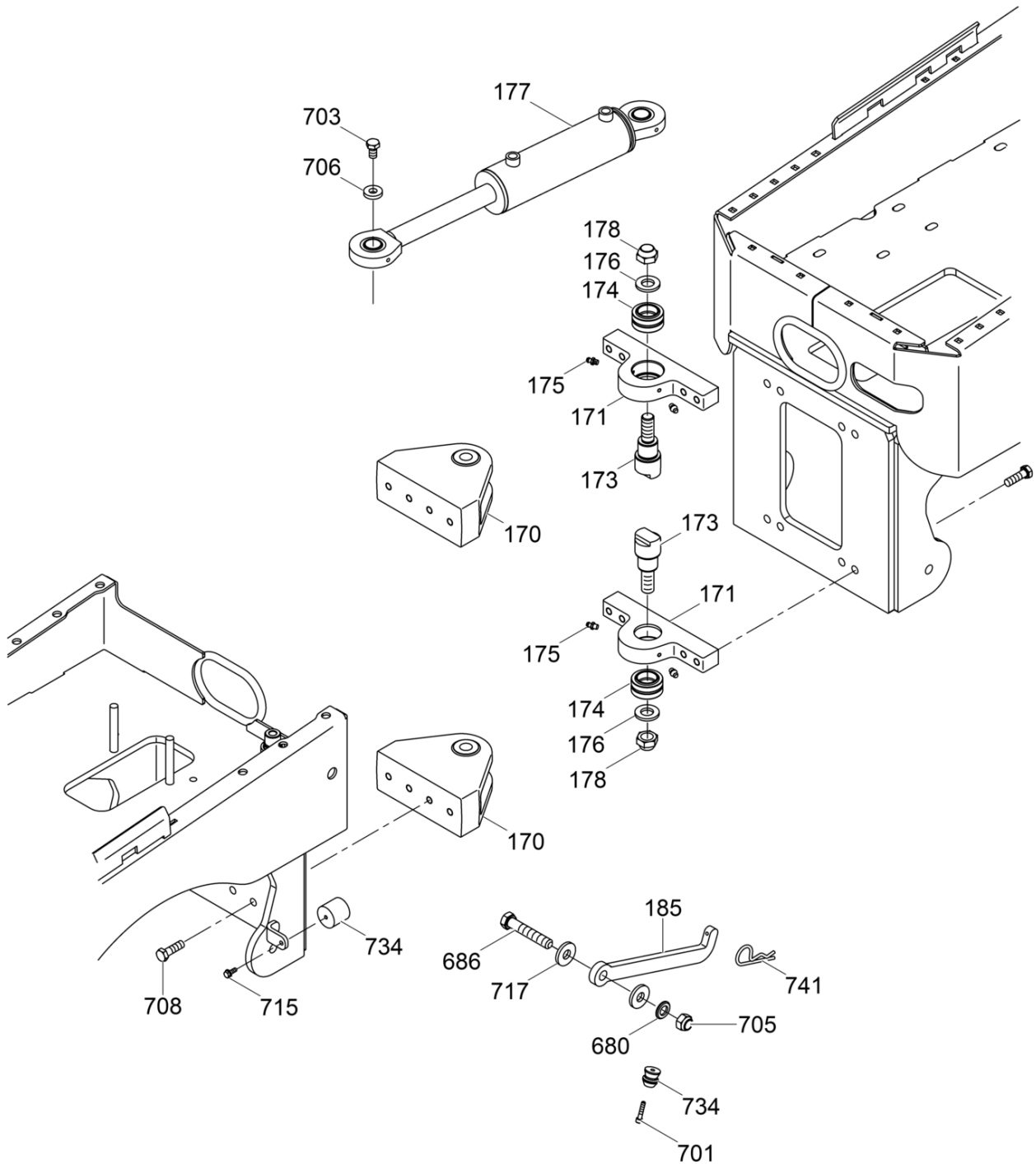

200_5200019255100003

Pos. Ref.	Artikel Nr. Part No.	Qty.	Unit	Beschreibung Description	Description Description	Abm. Measur.	Norm Standard
						Drehm. Torque	Schmierstoff Sealant
170	5000115448	2	pc	Drehteil Pivote	Pivot Pivot		
171	5000089323	2	pc	Konsole Soporte	Bracket Support		
173	5000119066	2	pc	Stift Pasador	Pin Goupille		
174	5000079161	2	pc	Kugellager Rodamiento de bolas	Ball bearing Roulement à billes		
175	5002004705	4	pc	Kegelschmiernippel Grasera	Grease fitting Graisseur	AM6	DIN71412
176	5000119067	2	pc	Scheibe Arandela	Washer Rondelle		
177	5000117018	1	pc	Hydrozylinder Cilindro hidráulico	Hydraulic cylinder Cylindre hydraulique		
178	5000017088	2	pc	Sicherungsmutter Contratuerca	Lock nut Contre-écrou	M20	
185	5000119629	1	pc	Riegel Seguro	Lock arm Verrou		
680	5000010618	1	pc	Scheibe Arandela	Flat washer Rondelle	16	DIN125-1
686	5000011382	1	pc	Sechskantschraube Tornillo hexagonal	Hexagonal head cap screw Vis à tête hexagonale	M16 x 90 210Nm/155ft.lbs	DIN931
701	5000011549	1	pc	Zylinderschraube Tornillo cilíndrico	Cheese head screw Vis à tête cylindrique	M6 x 30 17Nm/13ft.lbs	ISO4762
703	5000012368	2	pc	Sechskantschraube Tornillo hexagonal	Hexagonal head cap screw Vis à tête hexagonale	M12 x 20 86Nm/63ft.lbs	DIN933
705	5000011382	1	pc	Sechskantschraube Tornillo hexagonal	Hexagonal head cap screw Vis à tête hexagonale	M16 x 90 210Nm/155ft.lbs	DIN931
706	5000013618	2	pc	Scheibe Arandela	Flat washer Rondelle	13	DIN7349
708	5000016434	16	pc	Schraube Tornillo	Screw Vis	M12 x 40 86Nm/63ft.lbs	
715	5000028949	1	pc	Schraube Tornillo	Screw Vis	M6 x 16 10Nm/7ft.lbs	
717	5000031121	2	pc	Scheibe Arandela	Washer Rondelle		
734	5000111536	1	pc	Verriegelung Aldaba	Latch Loquet		
741	5002005276	1	pc	Splint Clavija hendida	Cotter pin Goupille fendue	No.3-9/16in	
1274	5000165049	1	pc	Schlauchschutz Protector de manguera	Hose guard Protecteur		

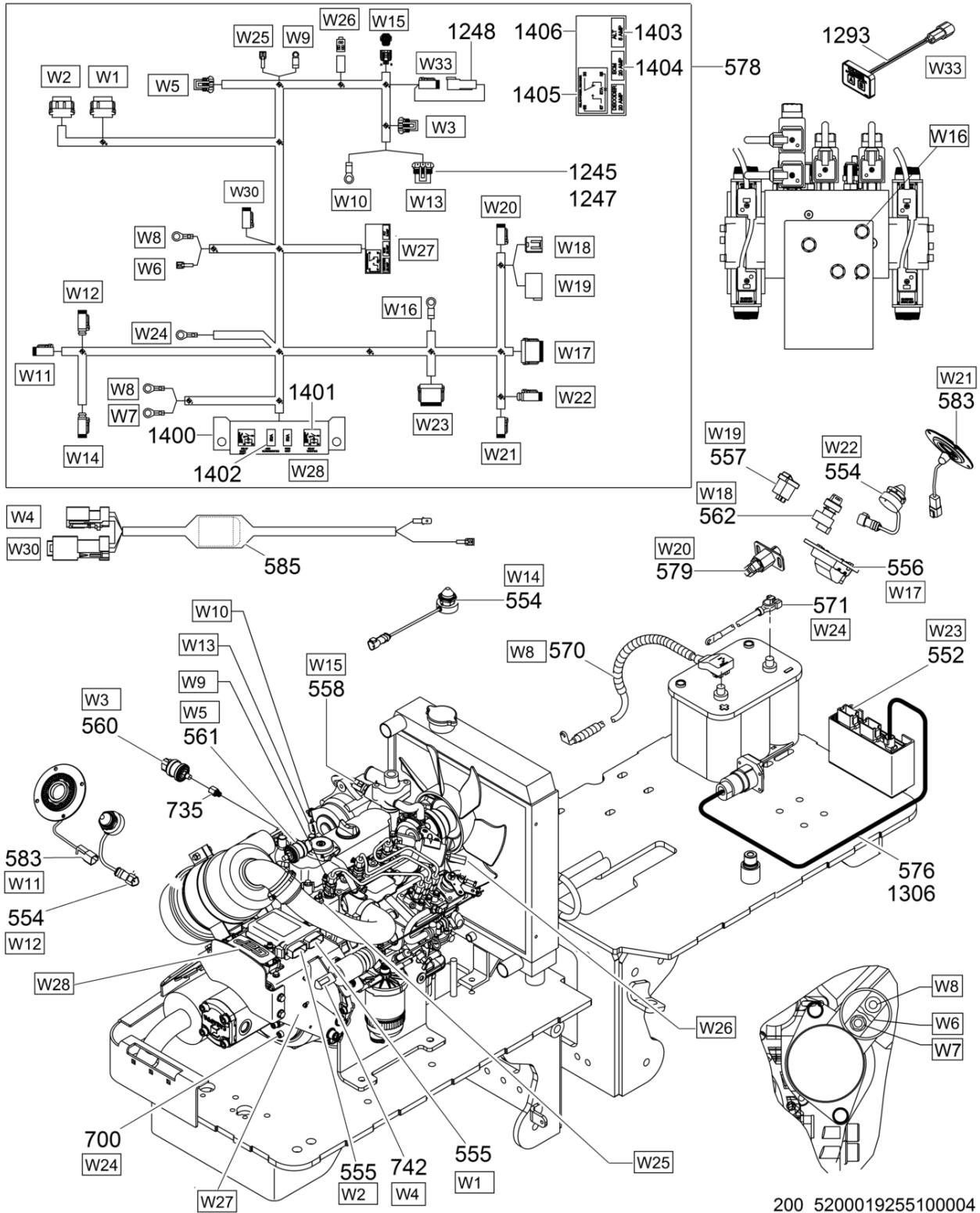

200_5200019255100004

Pos. Ref.	Artikel Nr. Part No.	Qty.	Unit	Beschreibung Description	Description Description	Abm. Measur.	Norm Standard
						Drehm. Torque	Schmierstoff Sealant
552	5000165515	1	pc	Decodiermodul Módulo decodificador	Decoder module Module de décodage		
554	5000170949	3	pc	Empfängerauge Receptor de rayos	Infrared sensor Oeil récepteur		
555	5200025081	1	pc	Motorkontrollmodul Módulo de mando del motor	Engine control module Module de contrôle de moteur		
556	5000178862	1	pc	Anzeigemodul Módulo de visualización	Display module Module d'affichage		
557	5000150110	1	pc	Schalter Interruptor	Switch Interrupteur		
558	5100039854	1	pc	Temperatursensoreinheit Unidad de alerta de temperatura	Temperature sensor Appareil d'alerte de températu		
560	5200024858	1	pc	Öldruckschalter Interruptor de presión de aceite	Oil pressure switch Interrupteur à pression d'huile		
561	5000150114	1	pc	Vakuumschalter Interruptor	Vacuum switch Interrupteur à vide		
562	5000150115	1	pc	Zündschalter Interruptor de encendido	Ignition switch Interrupteur d'ignition		
570	5200017874	1	pc	Plusbatteriekabel Cable positivo de batería	Positive battery cable Câble positif de batterie		
571	5200017875	1	pc	Minusbatteriekabel Cable negativo de batería	Negative battery cable Câble négatif de batterie		
576	5000170950	1	pc	Stecker Und Kabelbaum Kpl. Enchufe y conjunto de cables compl.	Plug and harness cpl. Fiche et harnais de câbles éle		
578	5200016533	1	pc	Motorkabelbaum Conjunto de cables de motor	Engine wiring harness Harnais de câbles électriques		
579	5000154405	1	pc	Ladungsanschlussmodul Módulo de toma de carga	Charge port module Module de prise de charge		
583	5000154403	2	pc	Lichtringmodul Módulo de anillo de luz	Light ring module Module de l'anneau lumineux		
585	5100031355	1	pc	Kabelbaum Conjunto de cables	Wiring harness Harnais de câbles électriques		
700	5000157154	1	pc	Sechskant-Schraube Tornillo hueco	Screw-socket head Vis à six-pans creux	M8 x 16	
735	5200018074	1	pc	Zwischenverschraubung Unión con adaptador	Adapter fitting Raccord intermédiaire	1/8 BSPT x 1/8 NPT	
742	5000155486	1	pc	Gasreglerstellteil Actuador de acelerador	Throttle actuator Dispositif de commande des gaz		
1245	5000160840	1	pc	2-Pol Stecker Enchufe	Connector housing, 2 pole, plug Fiche		
1247	5000160842	1	pc	Haltekeil Cuña de retención	Lock wedge Cale de fixation		
1248	5000161278	1	pc	Kabelbaum Für Kühlmittelumlauf Conjunto de cables para desviación del enfriador	Coolant bypass wiring harness Harnais de câbles électriques		
1293	5000172989	1	pc	Diagnose-Controllermodul Módulo controlador de diagnóstico	Diagnostic control module Module contrôle de diagnostic		
1306	5000182304	1	pc	Anschlußteil Conector	Connector Connecteur		
1400	5200025185	1	pc	Gehäuse Kpl. Caja compl.	Housing cpl. Carter compl.		
1401	5200025184	2	pc	Relais Relai	Relay Relais	12V, 70A	
1402	5000158713	2	pc	Sicherung Fusible	Fuse Fusible	50A	
1403	5200025183	1	pc	Sicherung Fusible	Fuse Fusible	5A	

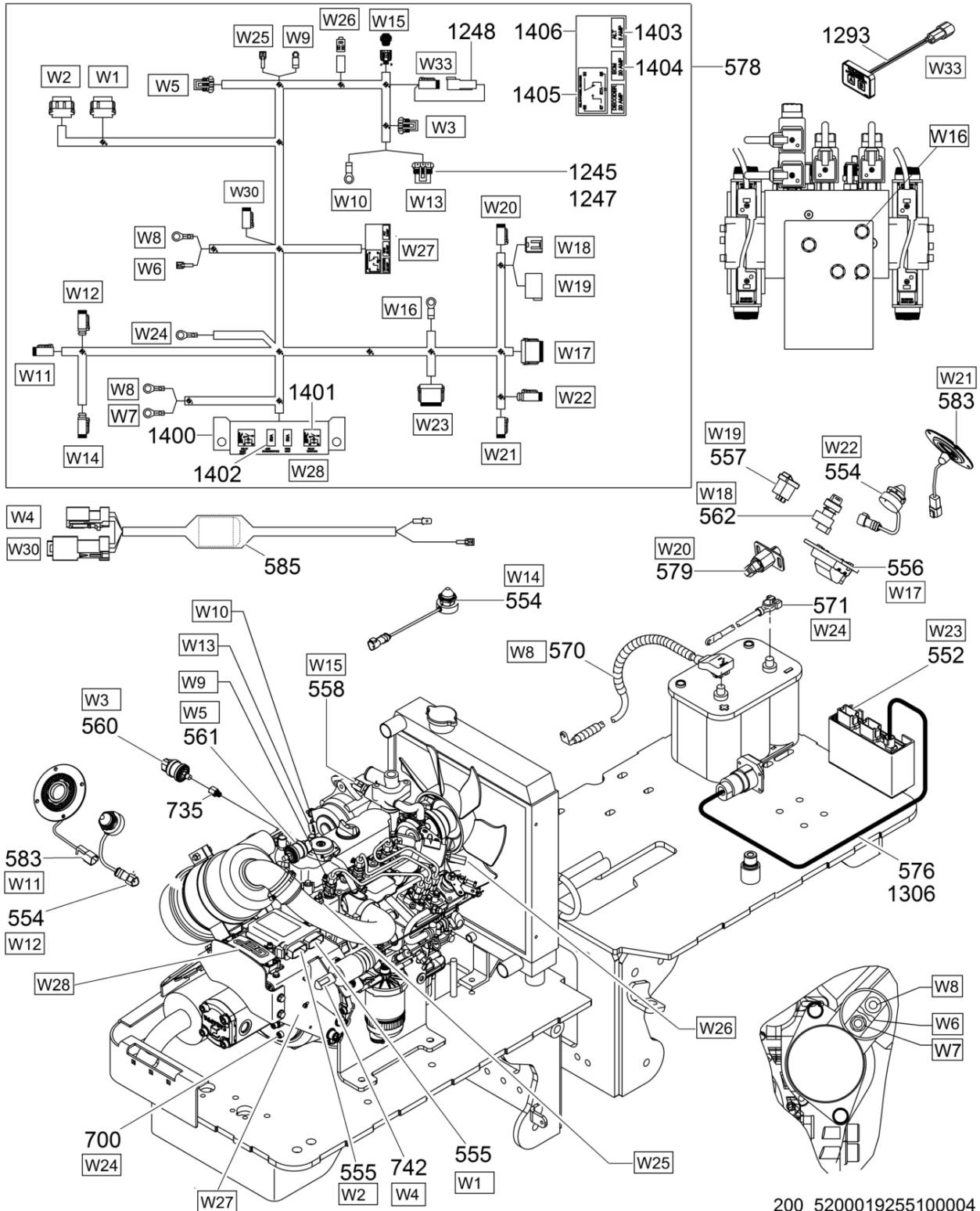

Pos. Ref.	Artikel Nr. Part No.	Qty.	Unit	Beschreibung Descripcion	Description Description	Abm. Measuram.	Norm Standard
						Drehm. Torque	Schmierstoff Sealant
1404	5000153489	2	pc	Sicherung Fusible	Fuse Fusible	20A	
1405	5200008565	1	pc	Relais Relai	Relay Relais		
1406	5200025190	1	pc	Gehäuse Kpl. Caja compl.	Housing cpl. Carter compl.		

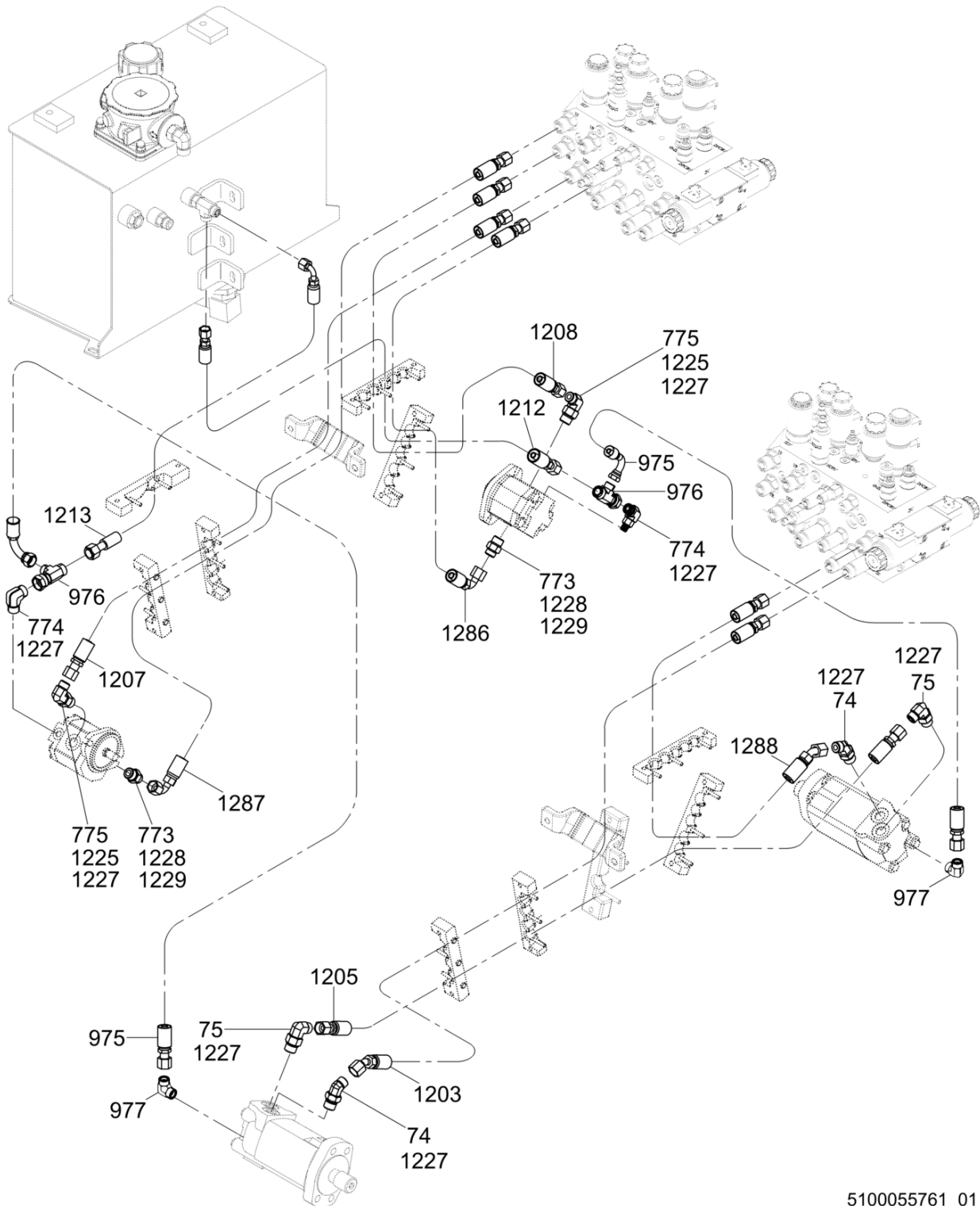

5100055761_01

Pos. Ref.	Artikel Nr. Part No.	Qty.	Unit	Beschreibung Descripción	Description Description	Abm. Measur.	Norm Standard
						Drehm. Torque	Schmierstoff Sealant
74	5000151767	2	pc	Hydraulikrohrkrümmer Codo hidráulico	Hydraulic elbow fitting Coude hydraulique	45	
75	5000081340	2	pc	Rohrkrümmer Codo	Elbow fitting Coude	No.8 x 10 x 90	
773	5000079875	2	pc	Hydraulikverschraubung Unión hidráulico	Hydraulic fitting Raccord hydraulique	No.8 x 10	
774	5000151768	2	pc	Hydraulikrohrkrümmer Codo hidráulico	Hydraulic elbow fitting Coude hydraulique	90	
775	5000081340	2	pc	Rohrkrümmer Codo	Elbow fitting Coude	No.8 x 10 x 90	
975	5100053785	2	pc	Fall Ablaufschlauch Manguera de drenaje de la caja	Case drain hose Case tuyau de vidange		
976	5100053685	2	pc	Hydraulikverschraubung Unión hidráulico	Hydraulic fitting Raccord hydraulique	No.6 ORFS	
977	5000111285	2	pc	Hydraulikrohrkrümmer Codo hidráulico	Hydraulic elbow fitting Coude hydraulique	SAE No.4 x 90	
1203	5200010939	1	pc	Hydraulikschlauch Manguera hidráulica	Hydraulic hose Tuyau hydraulique	1360	
1205	5200010940	1	pc	Hydraulikschlauch Manguera hidráulica	Hydraulic hose Tuyau hydraulique	1275 38Nm/28ft.lbs	
1207	5200006474	1	pc	Hydraulikschlauch Manguera hidráulica	Hydraulic hose Tuyau hydraulique	1470 60Nm/44ft.lbs	
1208	5200006478	1	pc	Hydraulikschlauch Manguera hidráulica	Hydraulic hose Tuyau hydraulique	995 54Nm/40ft.lbs	
1212	5000182222	1	pc	Hydraulikschlauch Manguera hidráulica	Hydraulic hose Tuyau hydraulique	985mm 41Nm/30ft.lbs	
1213	5000182221	1	pc	Hydraulikschlauch Manguera hidráulica	Hydraulic hose Tuyau hydraulique	1525mm 41Nm/30ft.lbs	
1225	5000080731	5	pc	O-Ring Anillo-o	O-ring Joint torique	0,47 x 0,07in #6	
1227	5000080737	16	pc	O-Ring Anillo-o	O-ring Joint torique	0,49 x 0,07in #8 ORFS	
1228	5000080732	8	pc	O-Ring Anillo-o	O-ring Joint torique	0,64 x 0,09in #8	
1229	5000080733	2	pc	O-Ring Anillo-o	O-ring Joint torique	0,76 x 0,10in #10	
1275	5000170004	1	pc	Schutzschlauchsatz Juego de manguera	Protective hose kit Jue de tuyau		
1286	5200006554	1	pc	Hydraulikschlauch Manguera hidráulica	Hydraulic hose Tuyau hydraulique	60Nm/44ft.lbs	
1287	5200006476	1	pc	Hydraulikschlauch Manguera hidráulica	Hydraulic hose Tuyau hydraulique	1510	
1288	5100014108	1	pc	Hydraulikschlauch Manguera hidráulica	Hydraulic hose Tuyau hydraulique	1060mm	

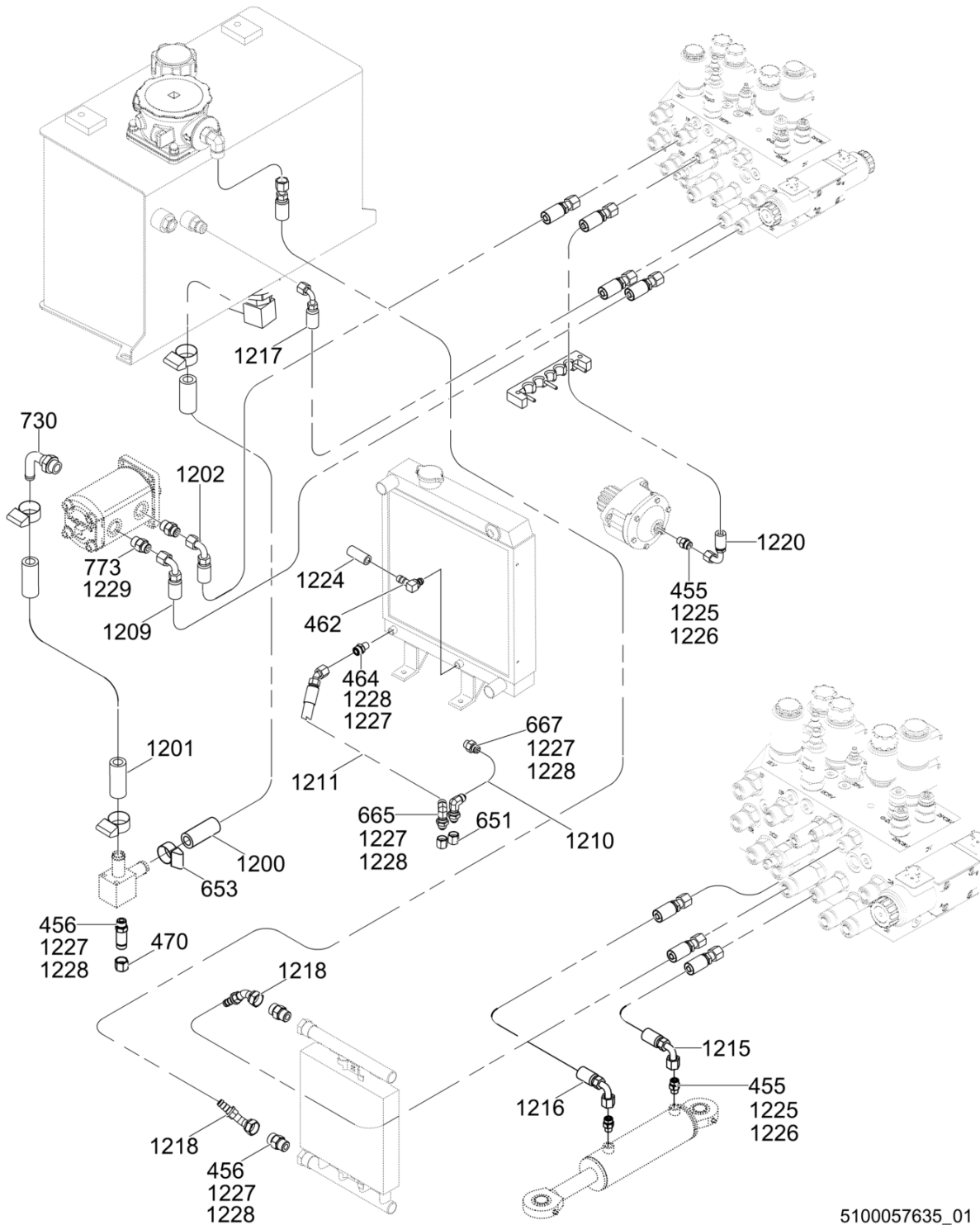

5100057635_01

Pos. Ref.	Artikel Nr. Part No.	Qty.	Unit	Beschreibung Descripción	Description Description	Abm. Measur.	Norm Standard
						Drehm. Torque	Schmierstoff Sealant
455	5000078816	3	pc	Zwischenverschraubung Unión con adaptador	Adapter fitting Raccord intermédiaire		
456	5000158572	2	pc	Verschraubung Unión	Fitting Raccord	No.8	
462	5000156401	1	pc	Verschraubung Unión	Fitting Raccord	90	
464	5000156204	1	pc	Verschraubung Unión	Fitting Raccord	No.8-3/8 NPT	
470	5000111716	1	pc	Kappe Tapa	Cap Capuchon	No.8	
651	5000119929	2	pc	Verschraubung, Kappe Unión, tapa	Fitting cap Raccord, capuchon	No.8	
653	5000150051	2	pc	Schlauchschelle Abrazaderas de manguera	Hose clamp Agrafe de tuyau	No.16	
665	5000119960	2	pc	Verschraubung Unión	Fitting Raccord	No.8	
667	5000119962	1	pc	Verschraubung Unión	Fitting Raccord	No.8	
730	5000088342	2	pc	Verschraubung Unión	Fitting Raccord	90	
773	5000079875	2	pc	Hydraulikverschraubung Unión hidráulico	Hydraulic fitting Raccord hydraulique	No.8 x 10	
1200	5000119663	1	pc	Hydraulikschlauch Manguera hidráulica	Hydraulic hose Tuyau hydraulique	1135	
1201	5200017878	1	pc	Hydraulikschlauch Manguera hidráulica	Hydraulic hose Tuyau hydraulique		
1202	5200020055	1	pc	Hydraulikschlauch Manguera hidráulica	Hydraulic hose Tuyau hydraulique	1560	
1209	5200017879	1	pc	Hydraulikschlauch Manguera hidráulica	Hydraulic hose Tuyau hydraulique	1610	
1210	5200017910	1	pc	Abflussschlauch Manguera de salida	Drain hose Tuyau d'écoulement		
1211	5200020054	1	pc	Abflussschlauch Manguera de salida	Drain hose Tuyau d'écoulement		
1215	5000182223	1	pc	Hydraulikschlauch Manguera hidráulica	Hydraulic hose Tuyau hydraulique	285mm 41Nm/30ft.lbs	
1216	5000182636	1	pc	Hydraulikschlauch Manguera hidráulica	Hydraulic hose Tuyau hydraulique	450mm	
1217	5000182224	1	pc	Hydraulikschlauch Manguera hidráulica	Hydraulic hose Tuyau hydraulique	425mm 41Nm/30ft.lbs	
1218	5000164955	2	pc	Hydraulikschlauch Manguera hidráulica	Hydraulic hose Tuyau hydraulique		
1220	5000182225	1	pc	Hydraulikschlauch Manguera hidráulica	Hydraulic hose Tuyau hydraulique	590mm 41Nm/30ft.lbs	
1224	5000119934	1	pc	Abflussschlauch Manguera de salida	Drain hose Tuyau d'écoulement	570	
1225	5000080731	5	pc	O-Ring Anillo-o	O-ring Joint torique	0,47 x 0,07in #6	
1226	5000080736	3	pc	O-Ring Anillo-o	O-ring Joint torique	0,36 x 0,07in #6 ORFS	
1227	5000080737	16	pc	O-Ring Anillo-o	O-ring Joint torique	0,49 x 0,07in #8 ORFS	
1228	5000080732	8	pc	O-Ring Anillo-o	O-ring Joint torique	0,64 x 0,09in #8	
1229	5000080733	2	pc	O-Ring Anillo-o	O-ring Joint torique	0,76 x 0,10in #10	

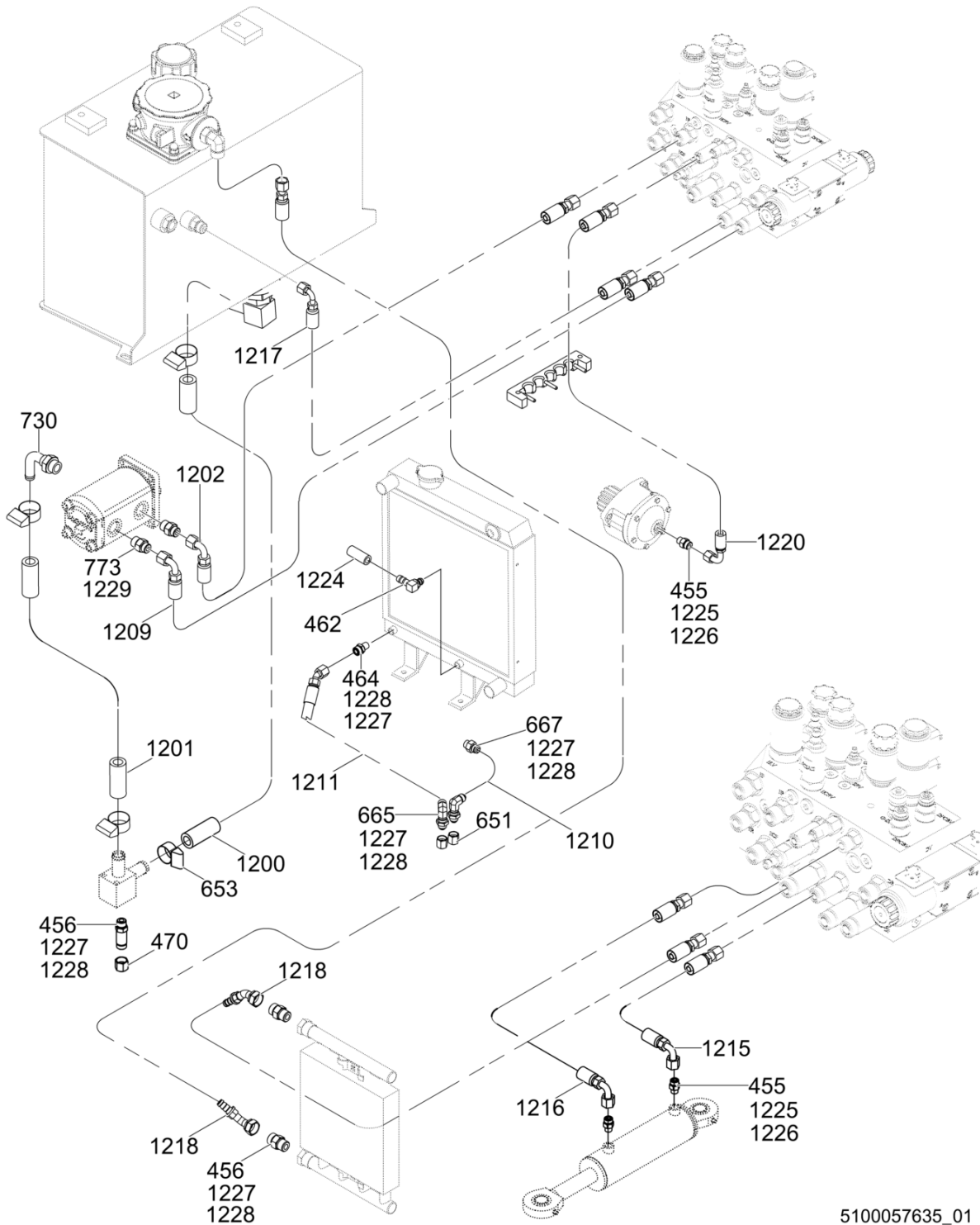

5100057635_01

Pos. Ref.	Artikel Nr. Part No.	Qty.	Unit	Beschreibung Descripcion	Description Description	Abm. Measurém.	Norm Standard
						Drehm. Torque	Schmierstoff Sealant
1275	5000170004	1	pc	Schutzschlauchsatz Juego de manguera	Protective hose kit Jue de tuyau		

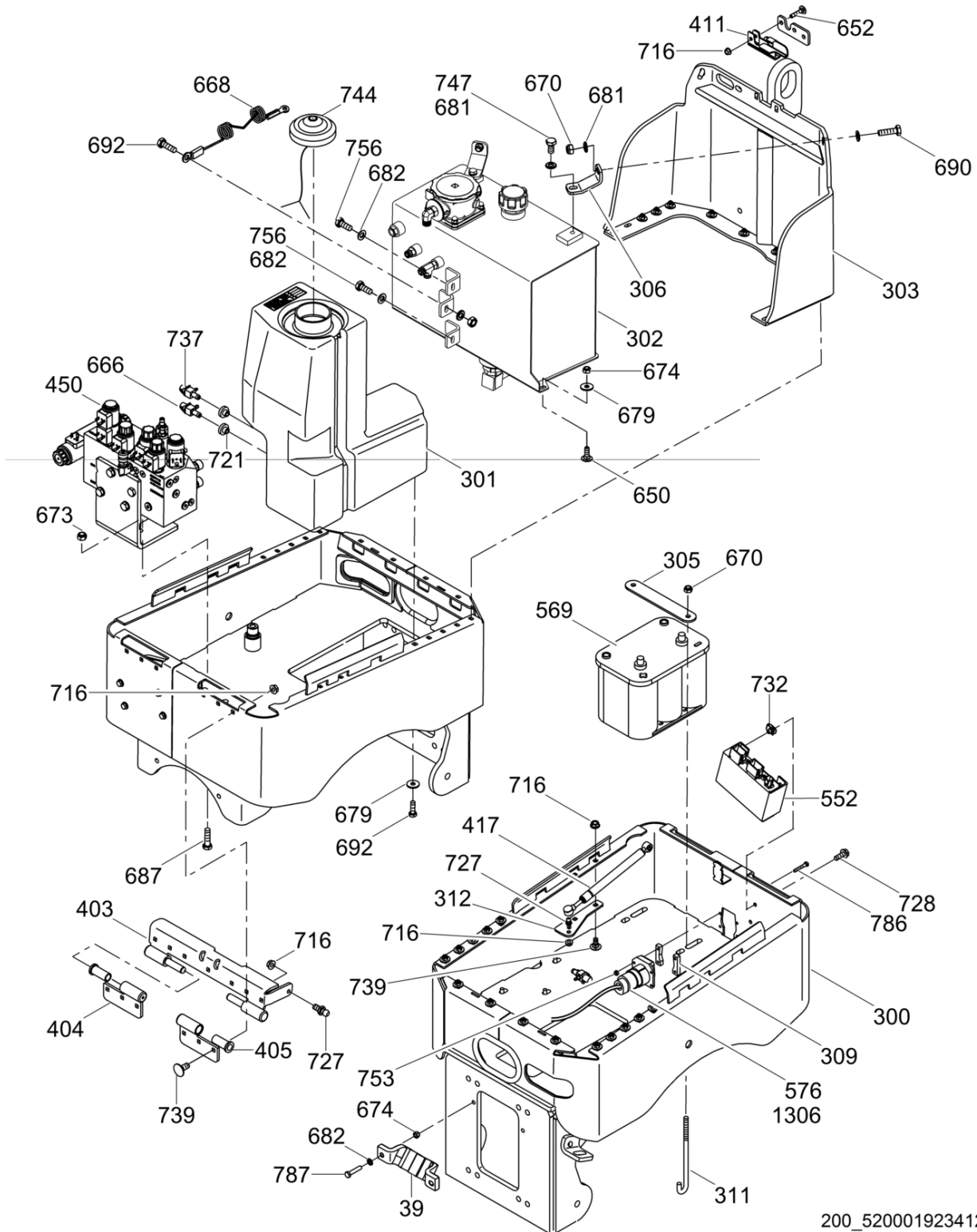

200_5200019234120003

Pos. Ref.	Artikel Nr. Part No.	Qty.	Unit	Beschreibung Descripción	Description Description	Abm. Measur.	Norm Standard
						Drehm. Torque	Schmierstoff Sealant
39	5100035870	1	pc	Schlauchführungshalter Support de guidage de tuyau	Hose guide bracket Soporte de la manguera		
300	5000117176	1	pc	Hinterrahmen Chasis de atrás	Rear frame Châssis arrière		
301	5000153625	1	pc	Kraftstofftank Depósito de combustible	Fuel tank Réservoir de carburant		
302	5200000844	1	pc	Hydrauliktank Tanque hidráulico	Hydraulic tank Réservoir hydraulique		
303	5000150089	1	pc	Gehäuse Caja	Housing Carter		
305	5000152305	1	pc	Platte Placa	Plate Plaque		
306	5000154260	1	pc	Konsole Soporte	Bracket Support		
309	5000154751	1	pc	Abstandsstück Espaciador	Spacer Entretoise		
311	5000156164	2	pc	Stange Varilla	Rod Tringle		
312	5000154712	1	pc	Konsole Soporte	Bracket Support		
403	5000119984	1	pc	Stift Pasador	Pin Goupille		
404	5000181474	2	pc	Scharnier Bisagra	Hinge Charnière		
405	5000164540	2	pc	Abstandshülse Espaciador	Bushing spacer Entretoise		
411	5000150098	1	pc	Verriegelung Aldaba	Latch Loquet		
417	5000150104	1	pc	Zylinder Cilindro	Cylinder Cylindre		
450	5100049600	1	pc	Hydraulikverteiler Distribuidor hidráulico	Hydraulic manifold Tubulure hydraulique		
552	5000165515	1	pc	Decodiermodul Módulo decodificador	Decoder module Module de décodage		
569	5000165552	1	pc	Batterie Batería	Battery Batterie	12V	
576	5000170950	1	pc	Stecker Und Kabelbaum Kpl. Enchufe y conjunto de cables compl.	Plug and harness cpl. Fiche et harnais de câbles éle		
650	5000157165	14	pc	Schloßschraube Tornillo de carruaje	Carriage bolt Boulon brut à tête bombée	M8 X 25 8,8	
652	5000157166	3	pc	Schloßschraube Tornillo de carruaje	Carriage bolt Boulon brut à tête bombée	M8 x 45	
666	5000119927	1	pc	Verschraubung Unión	Fitting Raccord	1/4in	
668	5000154402	1	pc	Kabel Cable	Cable Câble		
670	5000010365	4	pc	Sicherungsmutter Contratuerca	Lock nut Contre-écrou	M10 25Nm/18ft.lbs	DIN 980 V
673	5000010366	4	pc	Sechskantmutter Tuerca hexagonal	Hexagon nut Écrou hexagonal	M12X1.75	
674	5000010367	2	pc	Sechskantmutter Tuerca hexagonal	Hexagon nut Écrou hexagonal	M8	
679	5000160298	6	pc	Scheibe Arandela elástica	Flat washer Rondelle de ressort	B8.4	
681	5000010621	6	pc	Scheibe Arandela	Washer Rondelle		

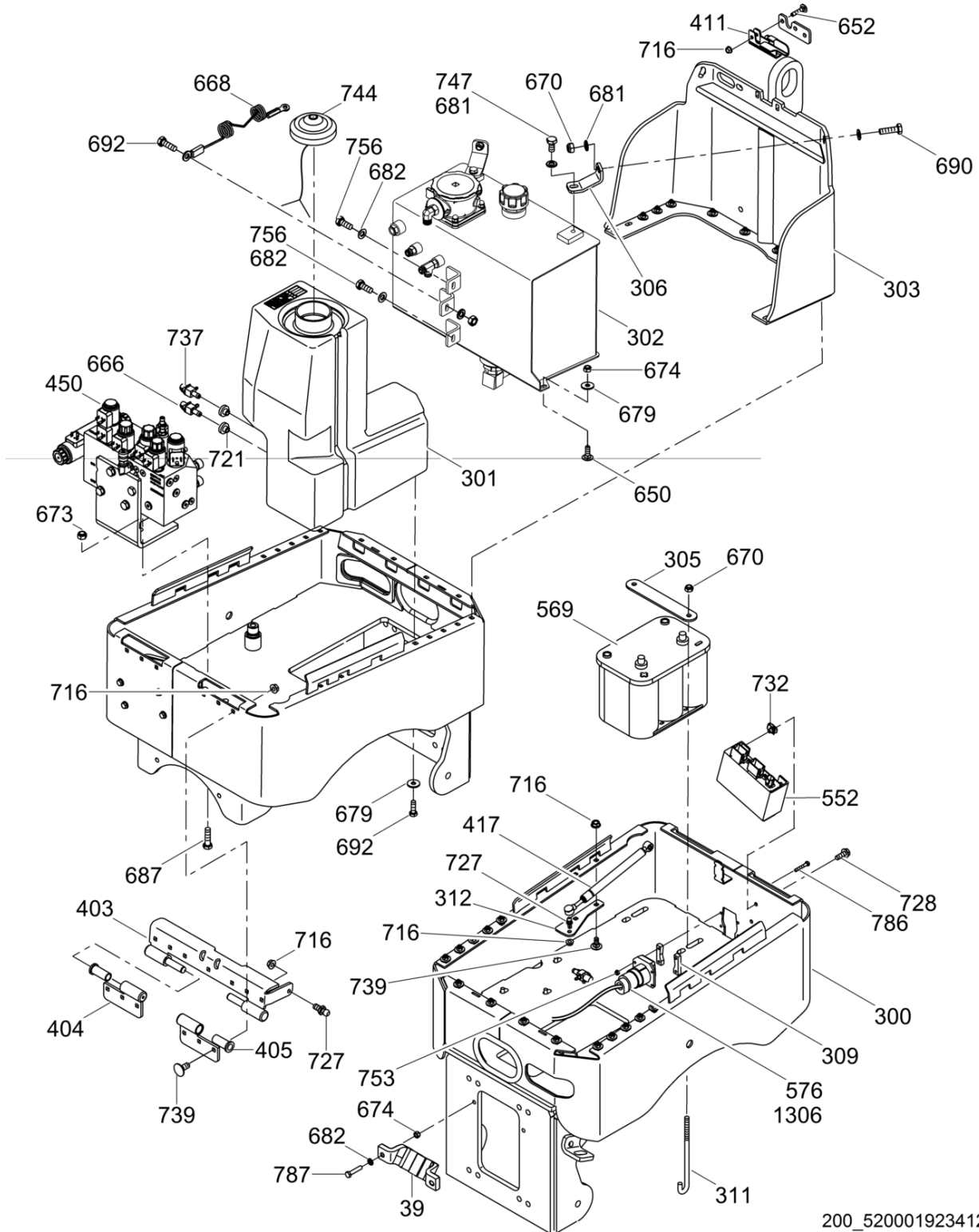

200_5200019234120003

Pos. Ref.	Artikel Nr. Part No.	Qty.	Unit	Beschreibung Description	Description Description	Abm. Measur.	Norm Standard
						Drehm. Torque	Schmierstoff Sealant
682	5000010622	4	pc	Scheibe Arandela	Flat washer Rondelle		
687	5000011420	4	pc	Sechskantschraube Tornillo hexagonal	Hexagonal head cap screw Vis à tête hexagonale	M12 x 45 86Nm/63ft.lbs	DIN933
690	5000011438	2	pc	Sechskantschraube Tornillo hexagonal	Hexagonal head cap screw Vis à tête hexagonale	M10 x 35 49Nm/36ft.lbs	DIN933
692	5000011457	6	pc	Sechskantschraube Tornillo hexagonal	Hexagonal head cap screw Vis à tête hexagonale	M8 x 25 7Nm/5ft.lbs	
716	5000030066	12	pc	Sechskantmutter Contratuerca	Locknut Contre-écrou	M8 7Nm/5ft.lbs	
721	5000053577	2	pc	Tankbuchse Buje	Tank valve bushing Douille		
727	5000155125	2	pc	Gewindebolzen Perno prisionero	Stud Goujon	M8 x 10	
728	5000087023	4	pc	Sechskantflanschschaube Tornillo hexagonal de brida	Hexagonal flange head screw Vis hexagonale de bride	M8 x 22 25Nm/18ft.lbs	
732	5000110969	4	pc	Klemmutter Sujetador	Clip nut Agrafe	M8	
737	5000157189	1	pc	Ventil Válvula	Valve Soupape	3/16in	
739	5000155841	8	pc	Schloßschraube Tornillo de carruaje	Carriage bolt Boulon brut à tête bombée	M8 x 20	
744	5100046509	1	pc	Tankverschluß Tapa del tanque	Fuel tank cap Chapeau de réservoir		
747	5000012364	1	pc	Sechskantschraube Tornillo hexagonal	Hexagonal head cap screw Vis à tête hexagonale	M10 x 20 49Nm/36ft.lbs	
753	5000010369	4	pc	Sechskantmutter Tuerca hexagonal	Hexagon nut Écrou hexagonal		
756	5000012362	2	pc	Sechskantschraube Tornillo hexagonal	Hexagonal head cap screw Vis à tête hexagonale	7Nm/5ft.lbs	
786	5000154898	4	pc	Sechskantschraube Tornillo hexagonal	Hexagonal head cap screw Boulon à tête hexagonale	M5 x 30	
867	5000160294	1	pc	Abstandsstück Espaciador	Spacer Entretoise		
1306	5000182304	1	pc	Anschlußsteil Conector	Connector Connecteur		

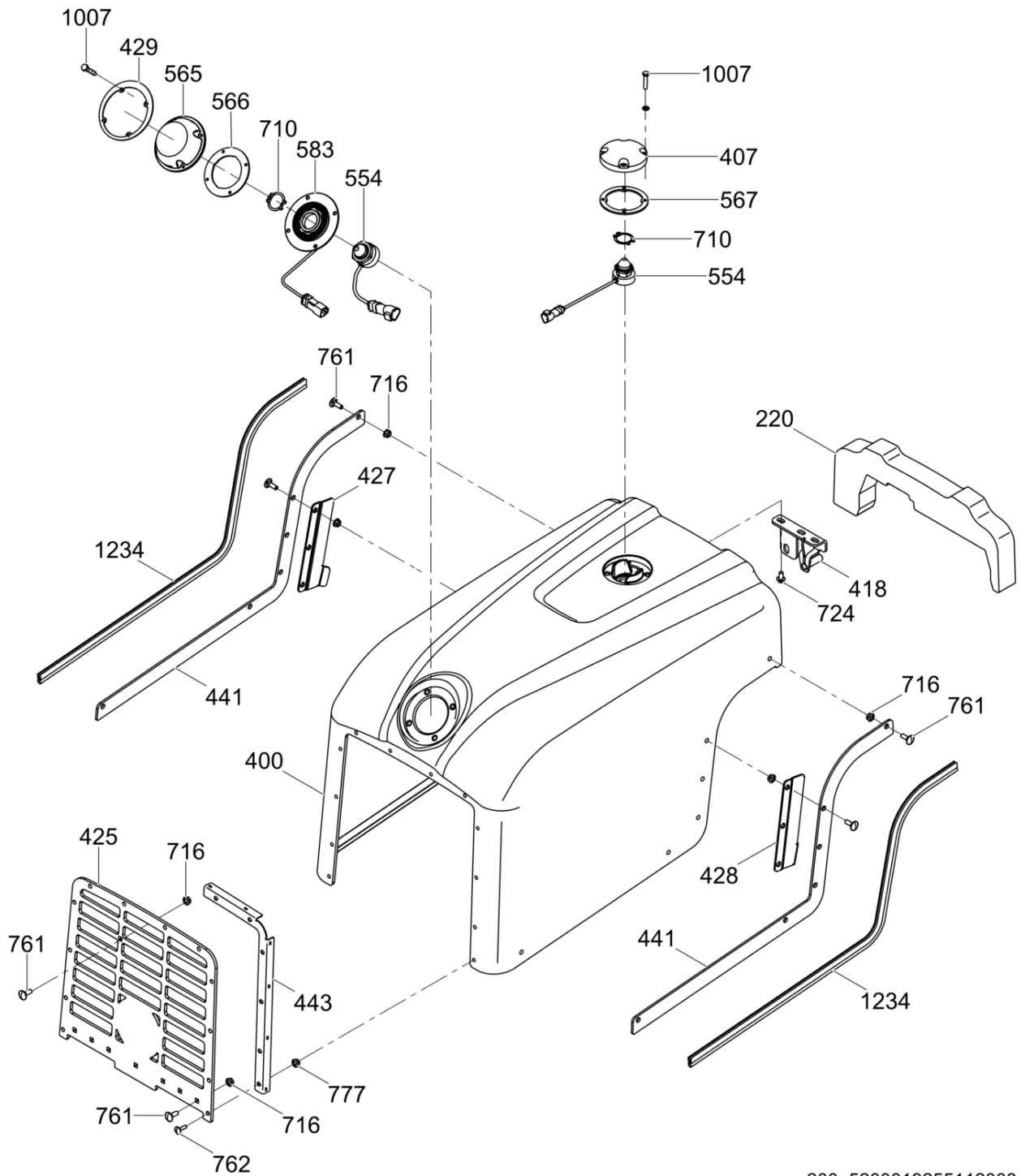

200_5200019255112008

Pos. Ref.	Artikel Nr. Part No.	Qty.	Unit	Beschreibung Description	Description Description	Abm. Measur.	Norm Standard
						Drehm. Torque	Schmierstoff Sealant
220	5000150227	1	pc	Dichtung Empaque	Seal Joint		
220	5200019759	1	pc	Profilgummi Moldura	Trim seal Garniture		
400	5200017704	1	pc	Vorderdeckel Tapa delantera	Front cover Couvercle avant		
407	5200018182	1	pc	Kappe Tapa	Cap Capuchon		
418	5200019751	1	pc	Konsole Soporte	Bracket Support		
425	5200019770	1	pc	Gitter Rejilla	Grille cover Grille		
427	5200019757	1	pc	Konsole Soporte	Bracket Support		
428	5200019758	1	pc	Konsole Soporte	Bracket Support		
429	5200019775	1	pc	Ring Anillo	Ring Anneau		
441	5200019755	2	pc	Konsole Soporte	Bracket Support		
443	5200019774	1	pc	Konsole Soporte	Bracket Support		
554	5000170949	2	pc	Empfängerauge Receptor de rayos	Infrared sensor Oeil récepteur		
565	5200011851	1	pc	Kappe Tapa	Cap Capuchon		
566	5100026695	1	pc	Dichtung Junta	Gasket Joint		
567	5100026696	1	pc	Dichtung Junta	Gasket Joint		
583	5100042609	1	pc	Lichtringmodul Módulo de anillo de luz	Light ring module Module de l'anneau lumineux		
710	5000172857	2	pc	Scheibe Arandela	Retaining washer Rondelle		
716	5000030066	20	pc	Sechskantmutter Contratuerca	Locknut Contre-écrou	M8	
724	5000155839	3	pc	Sechskantschraube Tornillo hexagonal	Hexagonal head cap screw Boulon à tête hexagonale	M8 x 16	
761	5000163950	20	pc	Schloßschraube Tornillo de carruaje	Carriage bolt Boulon brut à tête bombée	M8 x 25	
762	5000164579	12	pc	Schloßschraube Tornillo de carruaje	Carriage bolt Boulon brut à tête bombée	M6 x 25	
777	5000029117	12	pc	Sicherungsmutter Contratuerca	Lock nut Contre-écrou	M6	
1007	5000011474	8	pc	Sechskantschraube Tornillo hexagonal	Hexagonal head cap screw Vis à tête hexagonale	M5 x 25 6Nm/4ft.lbs	DIN933
1234	5000159561	2	pc	Profilgummi Moldura	Seal-trim Garniture	1000	

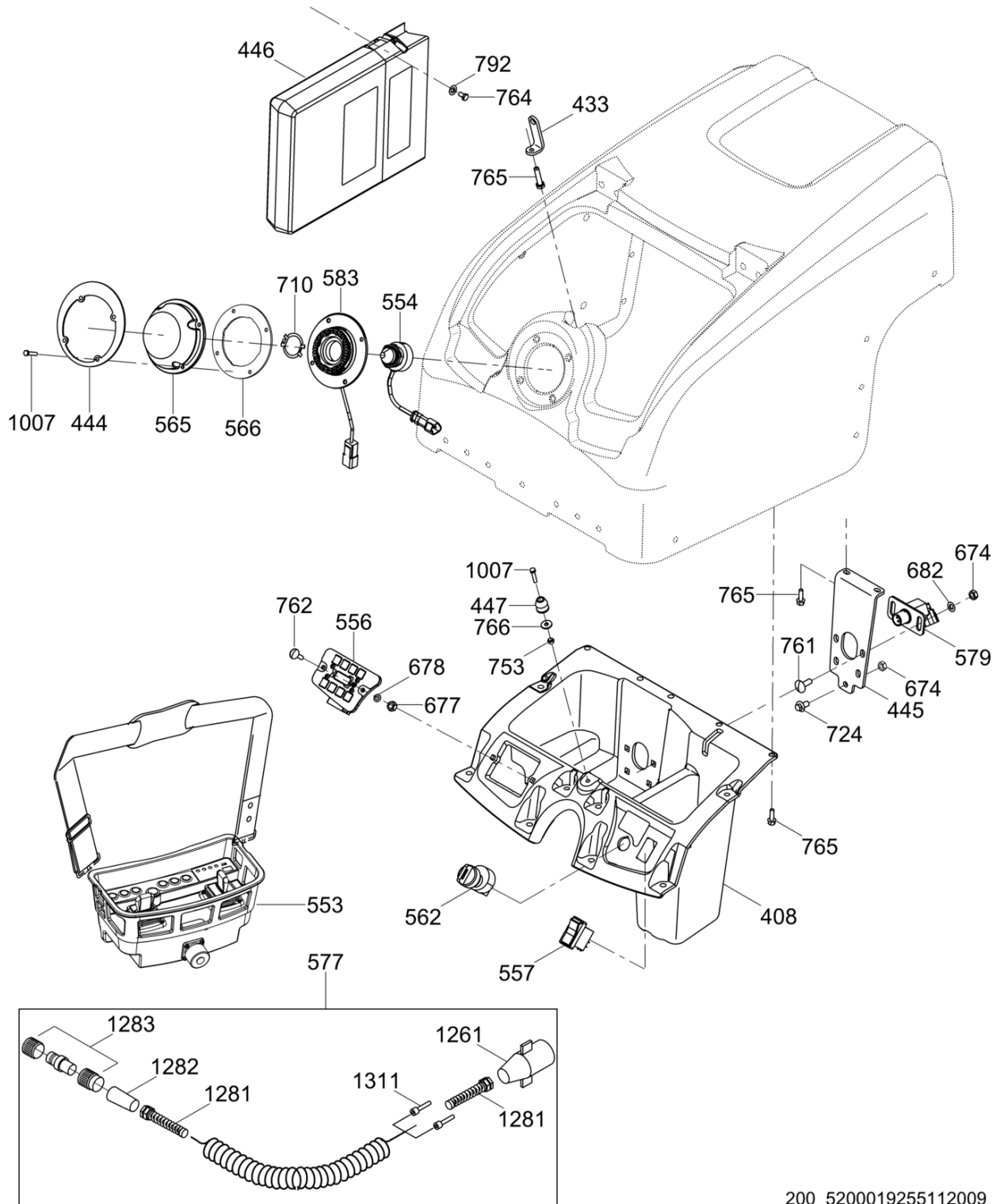

200_5200019255112009

Pos. Ref.	Artikel Nr. Part No.	Qty.	Unit	Beschreibung Description	Description Description	Abm. Measur.	Norm Standard
						Drehm. Torque	Schmierstoff Sealant
408	5200018183	1	pc	Bedienungskonsole Pupitre de mando	Console Panneau de contrôle		
433	5200019786	1	pc	Zunge Orejeta	Tab Onglet		
444	5200019779	1	pc	Konsole Ménsula	Mount Support		
445	5200019784	1	pc	Konsole Soporte	Bracket Support		
446	5000153425	1	pc	Handbuchhalter Soporte manual	Manual holder Support de manuel		
447	5000170979	1	pc	Türverriegelung Aldaba de puerta	Door latch Loquet de porte		
553	5000165514	1	pc	Sender Transmisor	Transmitter module Transmetteur		
554	5000170949	2	pc	Empfängerauge Receptor de rayos	Infrared sensor Oeil récepteur		
556	5000178862	1	pc	Anzeigemodul Módulo de visualización	Display module Module d'affichage		
557	5000150110	1	pc	Schalter Interruptor	Switch Interrupteur		
562	5000150115	1	pc	Zündschalter Interruptor de encendido	Ignition switch Interrupteur d'ignition		
565	5200011851	1	pc	Kappe Tapa	Cap Capuchon		
566	5100026695	1	pc	Dichtung Junta	Gasket Joint		
577	5000154417	1	pc	Ladungskabel Cable de carga	Charging cable Câble de charge		
579	5000178854	1	pc	Ladungsanschlussmodul Módulo de toma de carga	Charge port module Module de prise de charge		
583	5100042609	1	pc	Lichtringmodul Módulo de anillo de luz	Light ring module Module de l'anneau lumineux		
674	5000010367	4	pc	Sechskantmutter Tuerca hexagonal	Hexagon nut Écrou hexagonal	M8	
677	5000010368	2	pc	Sechskantmutter Tuerca hexagonal	Hexagon nut Écrou hexagonal	M6	DIN985
678	5000010624	2	pc	Scheibe Arandela	Flat washer Rondelle		
682	5000010622	2	pc	Scheibe Arandela	Flat washer Rondelle		
710	5000172857	1	pc	Scheibe Arandela	Retaining washer Rondelle		
724	5000155839	3	pc	Sechskantschraube Tornillo hexagonal	Hexagonal head cap screw Boulon à tête hexagonale	M8 x 16	
753	5000010369	1	pc	Sechskantmutter Tuerca hexagonal	Hexagon nut Écrou hexagonal		
761	5000163950	4	pc	Schloßschraube Tornillo de carruaje	Carriage bolt Boulon brut à tête bombée	M8 x 25	
762	5000164579	2	pc	Schloßschraube Tornillo de carruaje	Carriage bolt Boulon brut à tête bombée	M6 x 25	
764	5000012356	4	pc	Sechskantschraube Tornillo hexagonal	Hexagonal head cap screw Vis à tête hexagonale	M6 x 10 10Nm/7ft.lbs	DIN933
765	5200020974	1	pc	Sechskantflanschschaube Tornillo hexagonal de brida	Hexagonal flange head screw Vis hexagonale de bride	M6 x 20 10Nm/7ft.lbs	
765	5200020974	13	pc	Sechskantflanschschaube Tornillo hexagonal de brida	Hexagonal flange head screw Vis hexagonale de bride	M6 x 20 10Nm/7ft.lbs	

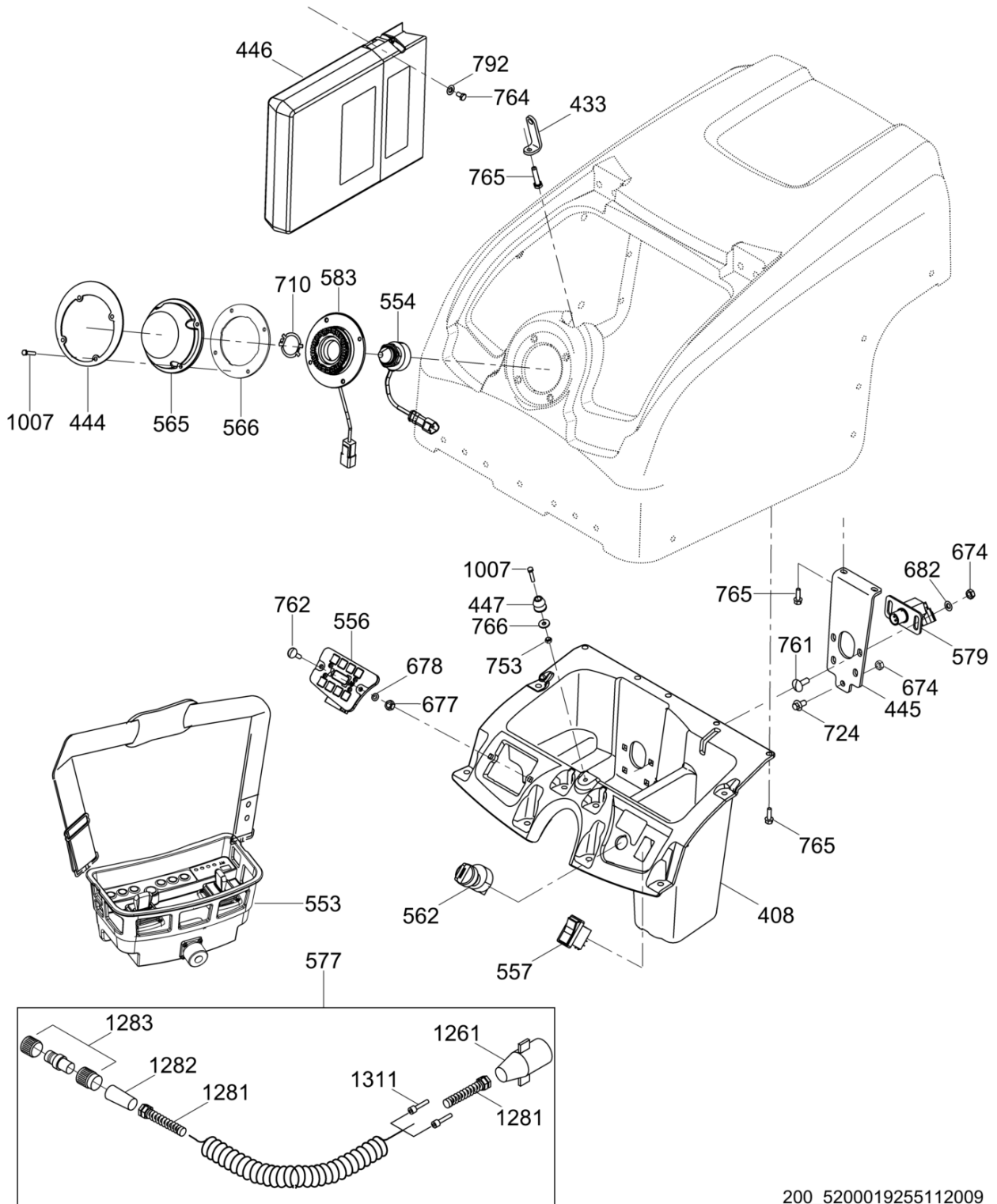

200_5200019255112009

Pos. Ref.	Artikel Nr. Part No.	Qty.	Unit	Beschreibung Description	Description Description	Abm. Measur.	Norm Standard
						Drehm. Torque	Schmierstoff Sealant
766	5000010372	1	pc	Scheibe Arandela	Flat washer Rondelle	B5,3	DIN9021
792	5000010373	4	pc	Scheibe Arandela	Flat washer Rondelle	6	ISO7093
1007	5000011474	5	pc	Sechskantschraube Tornillo hexagonal	Hexagonal head cap screw Vis à tête hexagonale	M5 x 25 6Nm/4ft.lbs	DIN933
1261	5000164490	1	pc	9-Stift Anschlussstecker Enchufe de (9 agujas)	Plug connector (9 pin) Fiche à (9 broches)		
1281	5000089676	2	pc	Zugentlastung Alivio de esfuerzos	Strain relief Effort à la décharge		
1282	5000088821	1	pc	Adapter Adaptador	Adaptor Adaptateur		
1283	5000116889	1	pc	Stopfen Kpl. Tapón compl	Plug cpl. Bouchon compl		
1311	5100037420	2	pc	Stiftklemme Terminal de pasador	Pin terminal Epingle terminal		

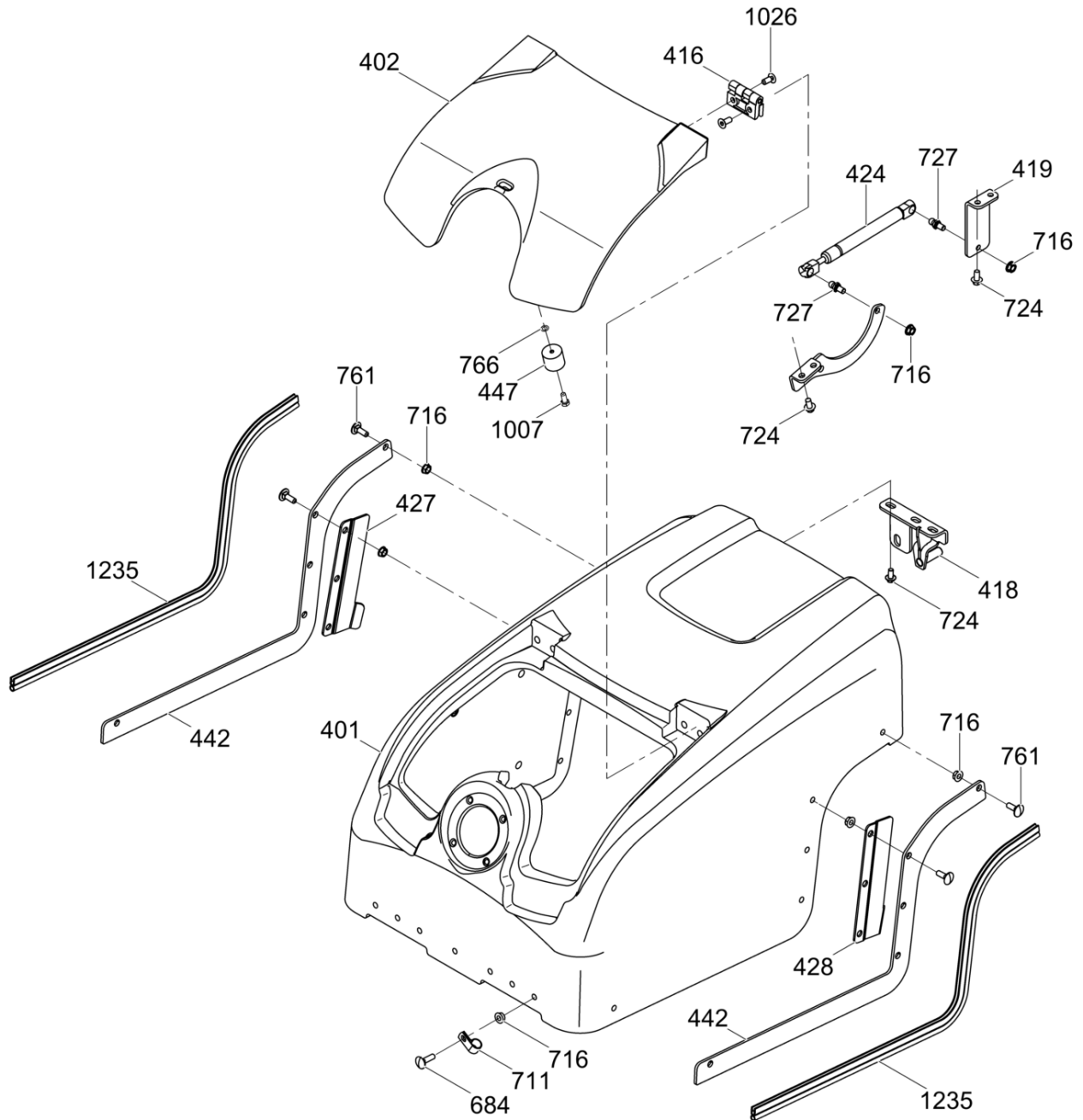

200_5200019255100010

Pos. Ref.	Artikel Nr. Part No.	Qty.	Unit	Beschreibung Descripción	Description Description	Abm. Measur.	Norm Standard
						Drehm. Torque	Schmierstoff Sealant
401	5200017705	1	pc	Hinterdeckel Tapa de atrás	Rear cover Couvercle arrière		
402	5200017707	1	pc	Abdeckplatte Tapa de acceso	Access cover Couvercle à accès		
415	5200023550	1	pc	Dichtungssatz Juego de juntas	Gasket set Jeu de joints		
416	5000154400	2	pc	Scharnier Bisagra	Hinge Charnière		
418	5200019751	1	pc	Konsole Soporte	Bracket Support		
419	5200019783	1	pc	Konsole Soporte	Bracket Support		
424	5000154401	1	pc	Zylinder Cilindro	Cylinder Cylindre		
427	5200019757	1	pc	Konsole Soporte	Bracket Support		
428	5200019758	1	pc	Konsole Soporte	Bracket Support		
442	5200019756	2	pc	Konsole Soporte	Bracket Support		
447	5000170979	1	pc	Türverriegelung Aldaba de puerta	Door latch Loquet de porte		
684	5000011151	7	pc	Schloßschraube Tornillo de carruaje	Carriage bolt Boulon brut à tête bombée	M8 x 30	DIN603
711	5000163956	1	pc	Schelle Abrazadera	Clamp Agrafe		
711	5000163957	1	pc	Rohrschelle Abrazadera para mangueras	Tube clamp Agrafe pour tuyaux souples	5/16in ID	
716	5000030066	19	pc	Sechskantmutter Contratuerca	Locknut Contre-écrou	M8	
724	5000155839	7	pc	Sechskantschraube Tornillo hexagonal	Hexagonal head cap screw Boulon à tête hexagonale	M8 x 16	
727	5000155125	1	pc	Gewindebolzen Perno prisionero	Stud Goujon	M8 x 10	
727	5000155125	2	pc	Gewindebolzen Perno prisionero	Stud Goujon	M8 x 10	
761	5000163950	10	pc	Schloßschraube Tornillo de carruaje	Carriage bolt Boulon brut à tête bombée	M8 x 25	
766	5000010372	1	pc	Scheibe Arandela	Flat washer Rondelle	B5,3	DIN9021
1007	5000011474	1	pc	Sechskantschraube Tornillo hexagonal	Hexagonal head cap screw Vis à tête hexagonale	M5 x 25 6Nm/4ft.lbs	DIN933
1026	5000021563	8	pc	Senkschraube Tornillo avellanado	Countersunk screw Vis noyée	M8 x 20 25Nm/18ft.lbs	ISO10642
1235	5000159562	2	pc	Profilgummi Moldura	Seal-trim Garniture	822	

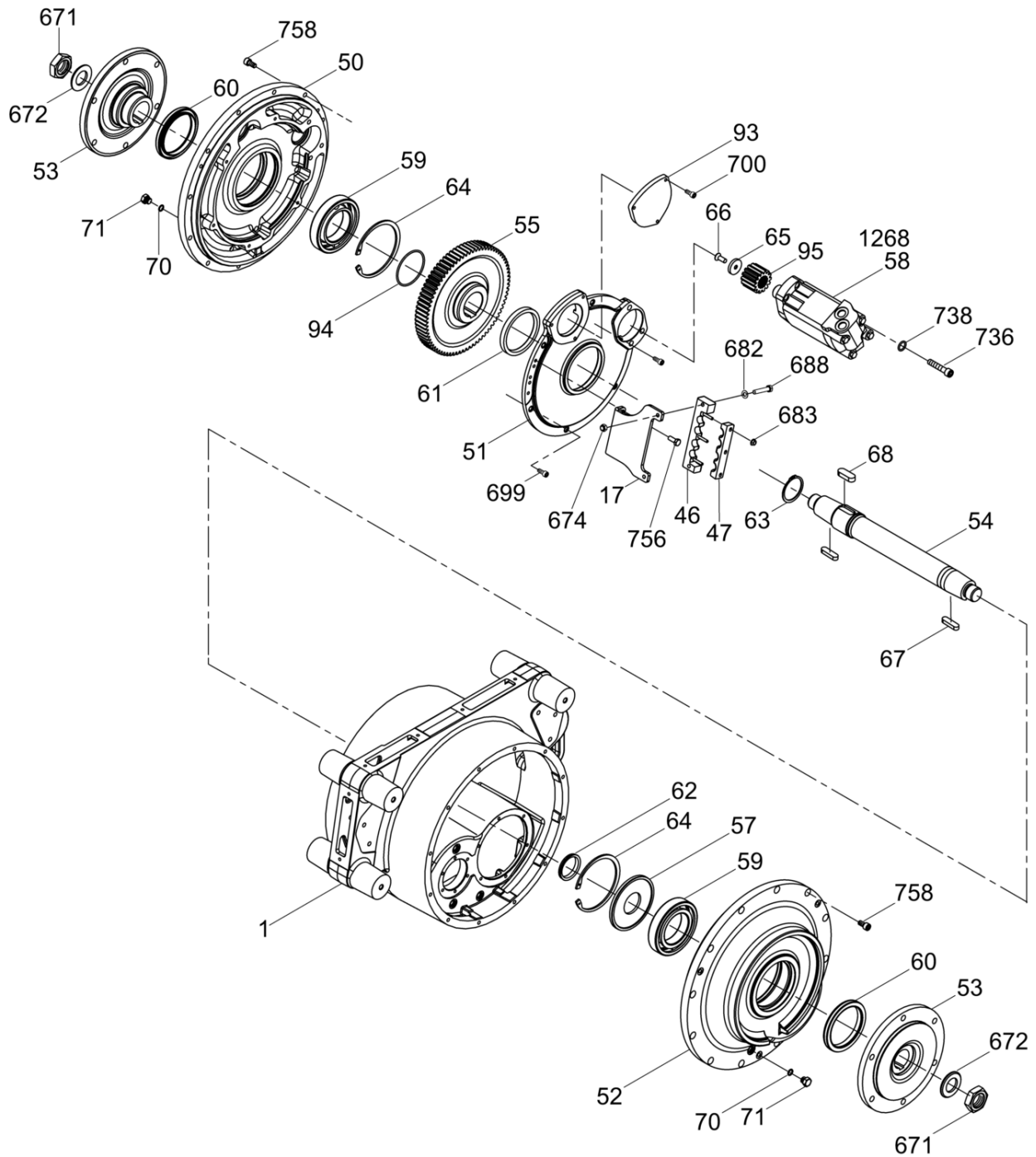

5200025155_02

Pos. Ref.	Artikel Nr. Part No.	Qty.	Unit	Beschreibung Description	Description Description	Abm. Measur.	Norm Standard
						Drehm. Torque	Schmierstoff Sealant
1	5000116902	1	pc	Bandagenträger Soporte del tambor	Drum support Support de tambour		
17	5200007278	1	pc	Konsole Soporte	Bracket Support		
46	5000150252	1	pc	Schlauchschelle Abrazaderas de manguera	Hose clamp Agrafe de tuyau		
47	5000150253	1	pc	Schlauchschelle Abrazaderas de manguera	Hose clamp Agrafe de tuyau		
50	5000118366	1	pc	Deckel Tapa	Cover Couvercle		
51	5000118368	1	pc	Deckel Tapa	Cover Couvercle		
52	5000116903	1	pc	Deckel Tapa	Cover Couvercle		
53	5000116906	2	pc	Bandagennabe Maza de tambor	Drum hub Moyeu de tambour		
54	5000116907	1	pc	Antriebswelle Eje motor	Drive shaft Arbre d'entraînement		
55	5000119284	1	pc	Zahnrad Engranaje	Gear Engrenage		
57	5000118796	1	pc	Scheibe Disco	Disc Disque		
58	5000181899	1	pc	Antriebsmotor Motor de accionamiento	Drive motor Moteur d'entraînement		
59	5000082961	2	pc	Rollenlager Rodamiento de rodillos	Roller bearing Roulement à rouleaux		
60	5000119285	2	pc	Dichtung Empaque	Seal Joint		
61	5000116874	1	pc	Wellendichtring Sello del eje	Shaft seal Bague d'étanchéité	100 x 120 x 12	
62	5000119286	1	pc	Wellendichtring Sello del eje	Shaft seal Bague d'étanchéité		
63	5000116869	1	pc	Sicherungsring Anillo de retención	Retaining ring Bague d'arrêt	62 x 2	DIN471
64	5000044706	2	pc	Sicherungsring Anillo de retención	Retaining ring Bague d'arrêt	140 x 4	DIN472
65	5000080666	1	pc	Scheibe Arandela	Washer Rondelle		
66	5000080667	1	pc	Schraube Tornillo	Screw Vis	3/8-16 x 1in	
67	5000116872	2	pc	Passfeder Chaveta	Square key Clavette	A14 x 9 x 50	DIN6885
68	5000116873	1	pc	Passfeder Chaveta	Square key Clavette	A18 x 11 x 50	DIN6885
70	5000014398	2	pc	O-Ring Anillo-o	O-ring Joint torique	12 x 2	
71	5000078269	2	pc	Schraubverschluss Tapón roscado	Plug (threaded) Bouchon	9/16-18in	
93	5000119505	1	pc	Platte Placa	Plate Plaque		
94	5000152276	1	pc	O-Ring Anillo-o	O-ring Joint torique	81,92 x 5,33	
95	5000154482	1	pc	Ritzel Piñon diferencial	Pinion gear Pignon		
671	5000116871	2	pc	Mutter Tuerca	Nut Écrou	M36 x 3 825Nm/609ft.lbs	

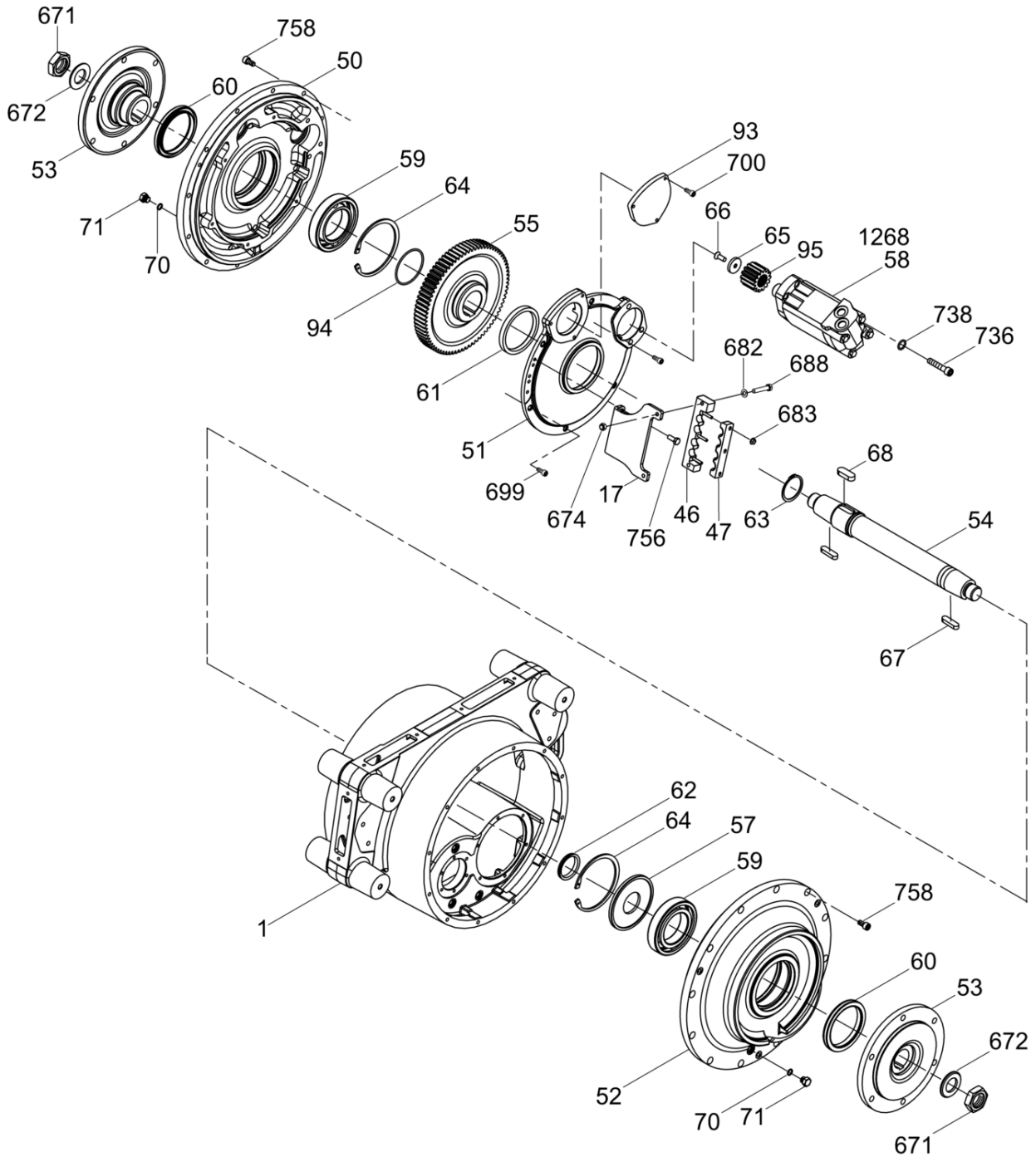

5200025155_02

Pos. Ref.	Artikel Nr. Part No.	Qty.	Unit	Beschreibung Descripcion	Description Description	Abm. Measur.	Norm Standard
						Drehm. Torque	Schmierstoff Sealant
672	5000150020	2	pc	Scheibe Arandela	Washer Rondelle	M36	
674	5000010367	2	pc	Sechskantmutter Tuerca hexagonal	Hexagon nut Écrou hexagonal	M8	
682	5000010622	2	pc	Scheibe Arandela	Flat washer Rondelle		
683	5000155519	3	pc	Flanschmutter Tuerca de reborde	Flange nut Ecrou de bride	M6	DIN 1661
688	5000117969	2	pc	Sechskantschraube Tornillo hexagonal	Hexagonal head cap screw Boulon à tête hexagonale	M8 x 45 25Nm/18ft.lbs	
699	5000011543	5	pc	Zylinderschraube Tornillo hueco	Socket head screw Vis à six-pans creux	M8 x 20 25Nm/18ft.lbs	ISO4762
700	5000011544	3	pc	Zylinderschraube Tornillo cilíndrico	Cheese head screw Vis à tête cylindrique	M8 x 16 41Nm/30ft.lbs	ISO4762
736	5100042214	3	pc	Zylinderschraube Tornillo cilíndrico	Socket head cap screw Vis à tête cylindrique	M12 x 60 85Nm/63ft.lbs	
738	5000010740	3	pc	Scheibe Arandela	Washer Rondelle	13	
756	5000012362	3	pc	Sechskantschraube Tornillo hexagonal	Hexagonal head cap screw Vis à tête hexagonale		
758	5000072758	30	pc	Zylinderschraube Tornillo cilíndrico	Cheese head screw Vis à tête cylindrique	M10 x 20 49Nm/36ft.lbs	ISO4762
1268	5000182756	1	pc	Dichtungssatz Juego-empaque	Seal kit Jeu-joint		

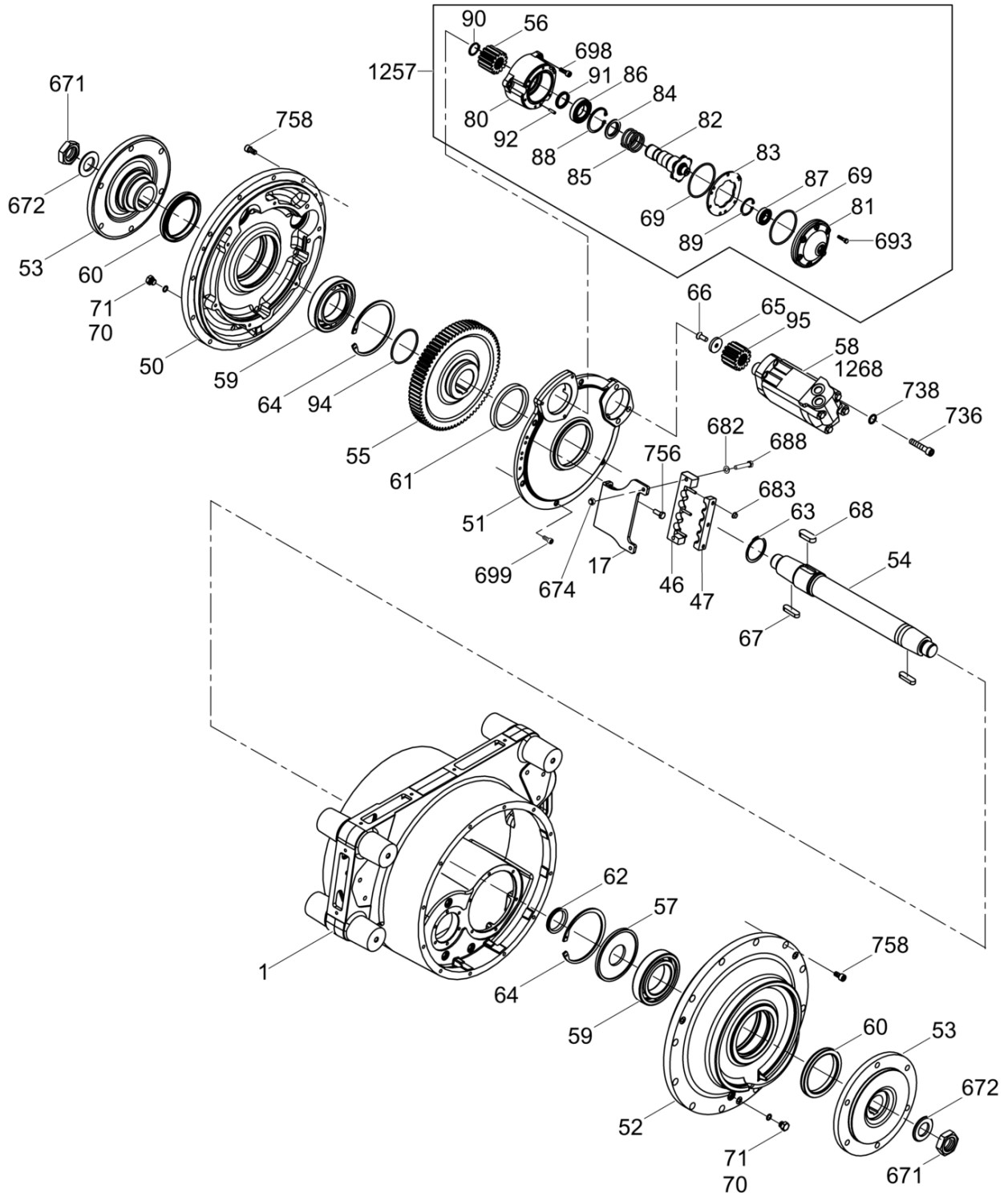

5200025156_02

Pos. Ref.	Artikel Nr. Part No.	Qty.	Unit	Beschreibung Description	Description Description	Abm. Measur.	Norm Standard
						Drehm. Torque	Schmierstoff Sealant
1	5000116902	1	pc	Bandagenträger Soporte del tambor	Drum support Support de tambour		
17	5200007278	1	pc	Konsole Soporte	Bracket Support		
40	5200008651	1	pc	Schelle Abrazadera	Clamp Agrafe		
41	5200008650	1	pc	Schelle Abrazadera	Clamp Agrafe		
50	5000118366	1	pc	Deckel Tapa	Cover Couvercle		
51	5000118368	1	pc	Deckel Tapa	Cover Couvercle		
52	5000116903	1	pc	Deckel Tapa	Cover Couvercle		
53	5000116906	2	pc	Bandagennabe Maza de tambor	Drum hub Moyeu de tambour		
54	5000116907	1	pc	Antriebswelle Eje motor	Drive shaft Arbre d'entraînement		
55	5000119284	1	pc	Zahnrad Engranaje	Gear Engrenage		
56	5000116909	1	pc	Ritzel Piñon diferencial	Pinion gear Pignon		
57	5000118796	1	pc	Scheibe Disco	Disc Disque		
58	5000181899	1	pc	Antriebsmotor Motor de accionamiento	Drive motor Moteur d'entraînement		
59	5000082961	2	pc	Rollenlager Rodamiento de rodillos	Roller bearing Roulement à rouleaux		
60	5000119285	2	pc	Dichtung Empaque	Seal Joint		
61	5000116874	1	pc	Wellendichtring Sello del eje	Shaft seal Bague d'étanchéité	100 x 120 x 12	
62	5000119286	1	pc	Wellendichtring Sello del eje	Shaft seal Bague d'étanchéité		
63	5000116869	1	pc	Sicherungsring Anillo de retención	Retaining ring Bague d'arrêt	62 x 2	DIN471
64	5000044706	2	pc	Sicherungsring Anillo de retención	Retaining ring Bague d'arrêt	140 x 4	DIN472
65	5000080666	1	pc	Scheibe Arandela	Washer Rondelle		
66	5000080667	1	pc	Schraube Tornillo	Screw Vis	3/8-16 x 1in	
67	5000116872	2	pc	Passfeder Chaveta	Square key Clavette	A14 x 9 x 50	DIN6885
68	5000116873	1	pc	Passfeder Chaveta	Square key Clavette	A18 x 11 x 50	DIN6885
69	5000119329	3	pc	O-Ring Anillo-o	O-ring Joint torique	85,32 x 3,53	
70	5000014398	2	pc	O-Ring Anillo-o	O-ring Joint torique	12 x 2	
71	5000078269	2	pc	Schraubverschluß Tapón roscado	Plug (threaded) Bouchon	9/16-18in	
80	5000119377	1	pc	Gehäuse Caja	Housing Carter		
81	5000117564	1	pc	Deckel Tapa	Cover Couvercle		

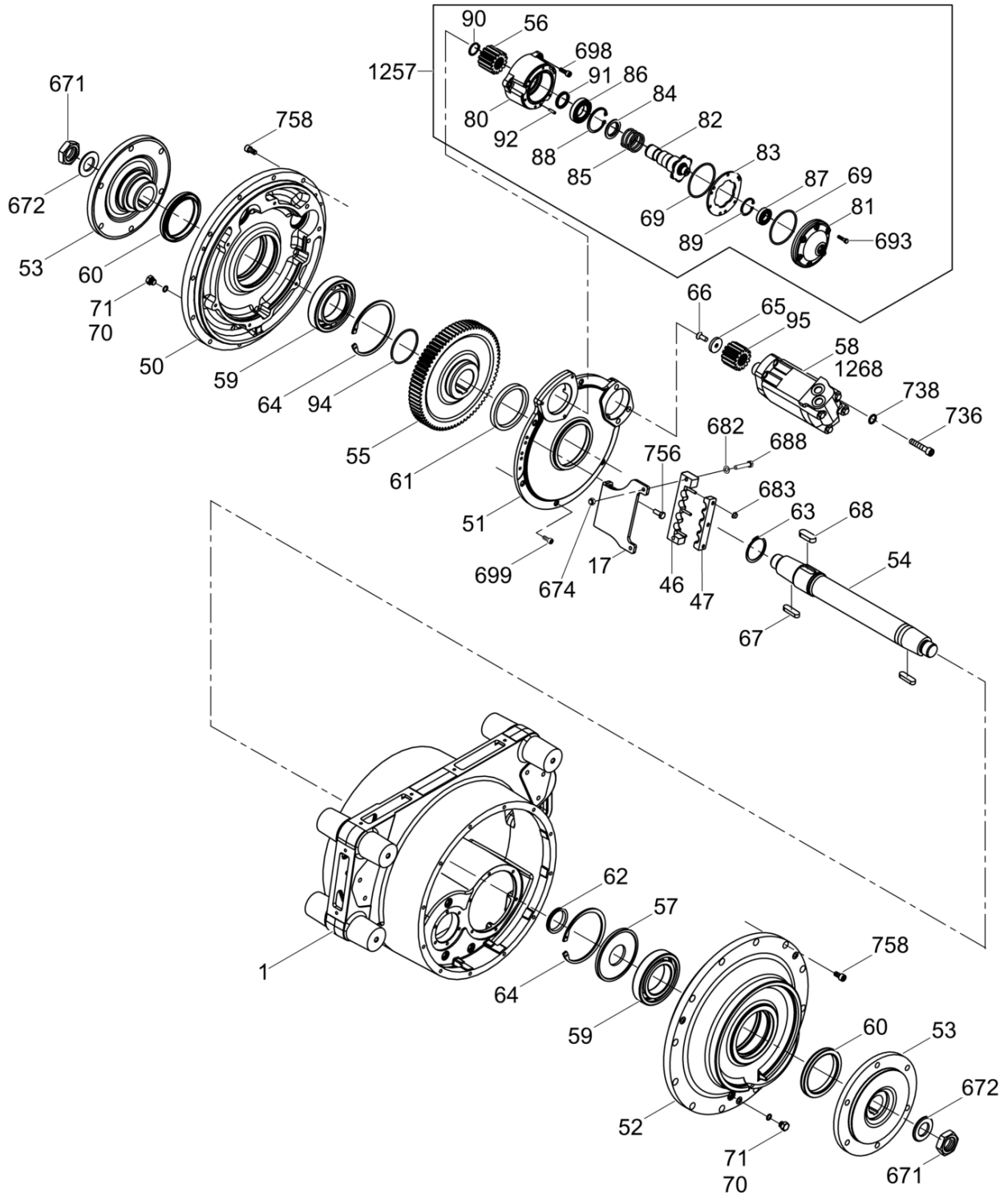

5200025156_02

Pos. Ref.	Artikel Nr. Part No.	Qty.	Unit	Beschreibung Description	Description Description	Abm. Measur.	Norm Standard
						Drehm. Torque	Schmierstoff Sealant
82	5000154320	1	pc	Welle Eje	Shaft Arbre		
83	5000117612	1	pc	Platte Placa	Plate Plaque		
84	5000151152	1	pc	Ring Anillo	Ring Anneau		
85	5000085783	1	pc	Feder Resorte	Spring Ressort		
86	5000027402	1	pc	Rillenkugellager Rodamiento de bolas	Grooved ball bearing Roulement à billes		
87	5002006236	1	pc	Rillenkugellager Rodamiento de bolas	Grooved ball bearing Roulement à billes		
88	5002001042	1	pc	Sicherungsring Anillo de retención	Retaining ring Bague d'arrêt	62 x 2	DIN472
89	5002004639	1	pc	Sicherungsring Anillo de retención	Retaining ring Bague d'arrêt	42 x 1,75	DIN472
90	5000152277	1	pc	Sicherungsring Anillo de retención	Retaining ring Bague d'arrêt	1,25 x 0,05	
91	5000089840	1	pc	Wellendichtring Sello del eje	Shaft seal Bague d'étanchéité		
92	5000054245	3	pc	Spannstift Pasador	Roll pin Goupille de tension	7/32 x 3/4 in	
93	5000119505	1	pc	Platte Placa	Plate Plaque		
94	5000152276	1	pc	O-Ring Anillo-o	O-ring Joint torique	81,92 x 5,33	
95	5000154482	1	pc	Ritzel Piñon diferencial	Pinion gear Pignon		
671	5000116871	2	pc	Mutter Tuerca	Nut Écrou	M36 x 3 825Nm/609ft.lbs	
672	5000150020	2	pc	Scheibe Arandela	Washer Rondelle	M36	
674	5000010367	2	pc	Sechskantmutter Tuerca hexagonal	Hexagon nut Écrou hexagonal	M8	
682	5000010622	2	pc	Scheibe Arandela	Flat washer Rondelle		
683	5000153379	3	pc	Dichtung Junta	Gasket Joint		
688	5000117969	2	pc	Sechskantschraube Tornillo hexagonal	Hexagonal head cap screw Boulon à tête hexagonale	M8 x 45 25Nm/18ft.lbs	
693	5000011469	6	pc	Sechskantschraube Tornillo hexagonal	Hexagonal head cap screw Vis à tête hexagonale	M6 x 25 10Nm/7ft.lbs	DIN933
698	5000011542	3	pc	Zylinderschraube Tornillo cilíndrico	Cheese head screw Vis à tête cylindrique	41Nm/30ft.lbs	
699	5000011543	4	pc	Zylinderschraube Tornillo hueco	Socket head screw Vis à six-pans creux	M8 x 20 25Nm/18ft.lbs	ISO4762
736	5100042214	3	pc	Zylinderschraube Tornillo cilíndrico	Socket head cap screw Vis à tête cylindrique	M12 x 60 106Nm/78ft.lbs	
738	5000010740	3	pc	Scheibe Arandela	Washer Rondelle	13	
756	5000012362	2	pc	Sechskantschraube Tornillo hexagonal	Hexagonal head cap screw Vis à tête hexagonale		
758	5000072758	30	pc	Zylinderschraube Tornillo cilíndrico	Cheese head screw Vis à tête cylindrique	M10 x 20 49Nm/36ft.lbs	ISO4762
1257	5000163621	1	pc	Bremse Kpl. Freno compl.	Brake cpl. Frein compl.		

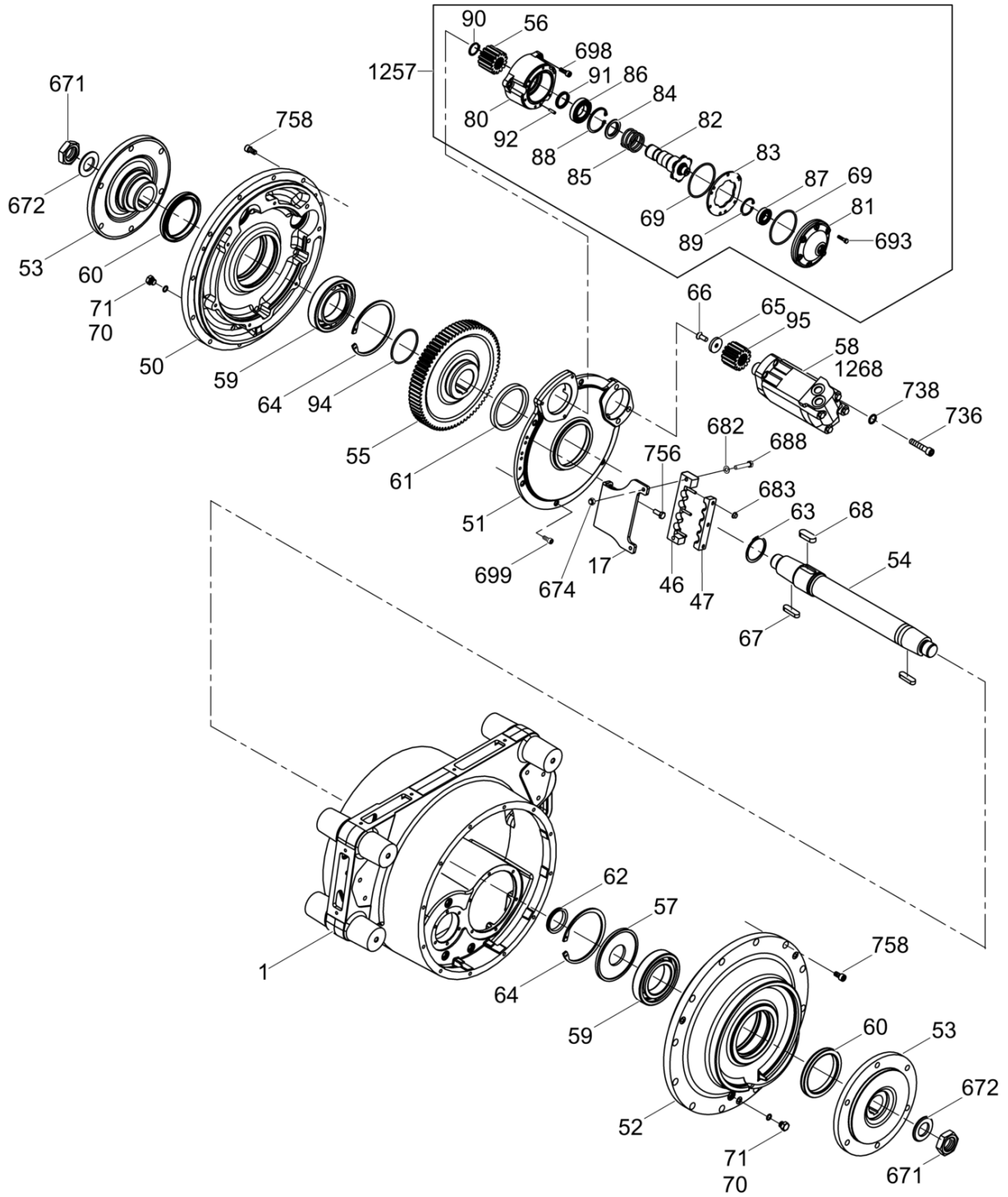

5200025156_02

Pos. Ref.	Artikel Nr. Part No.	Qty.	Unit	Beschreibung Descripcion	Description Description	Abm. Measur.	Norm Standard
						Drehm. Torque	Schmierstoff Sealant
1268	5000182756	1	pc	Dichtungssatz Juego-empaque	Seal kit Jeu-joint		
1689	5000011541	1	pc	Zylinderschraube Tornillo cilíndrico	Cheese head screw Vis à tête cylindrique		

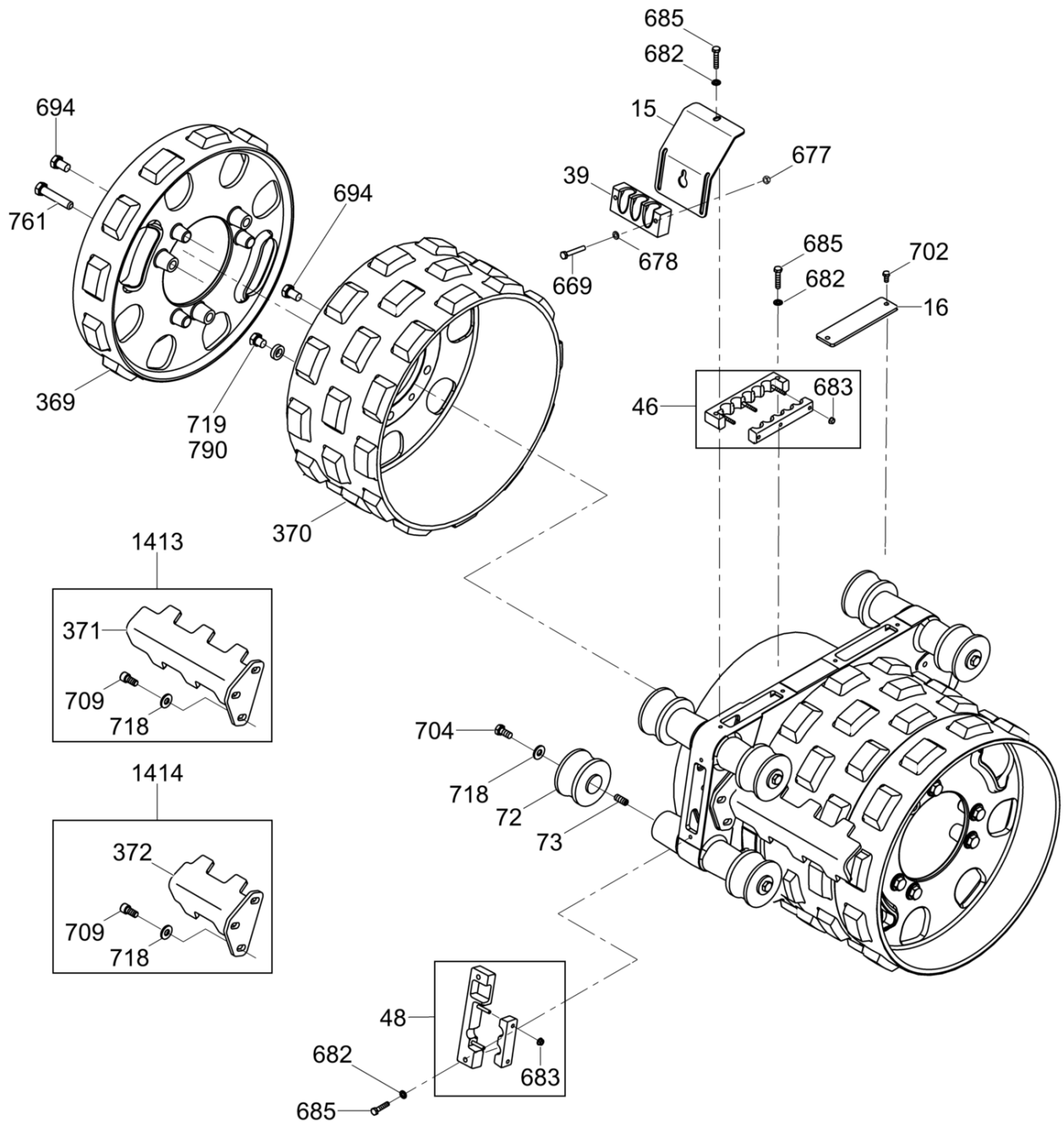

5200025158_01

Pos. Ref.	Artikel Nr. Part No.	Qty.	Unit	Beschreibung Description	Description Description	Abm. Measur.	Norm Standard
						Drehm. Torque	Schmierstoff Sealant
16	5000150306	1	pc	Platte Placa	Plate Plaque		
42	5200020383	1	pc	Schellensatz Juego de abrazaderas	Clamp set Jeu-agrafes		
44	5200020386	1	pc	Schellensatz Juego de abrazaderas	Clamp set Jeu-agrafes		
72	5002004814	6	pc	Gimmetall-Kerblager Mit Bund Amortiguador	Shockmount Silentbloc	100 x 58	
73	5000180963	6	pc	Gewindestift Tornillo	Setscrew Vis	M12 x 35	
369	5200003694	2	pc	Bandageverlängerung Tambor de extensión	Drum extension Extension de tambour		
370	5200009074	2	pc	Bandage-Schmal Tambor-angosto	Narrow drum Tambour étroit		
371	5200007069	1	pc	Bandage-Abstreifer Barra raspadora-ancho	Wide scraper Racleur large		
372	5200007072	1	pc	Bandage-Schmal Barra raspadora-angosto	Narrow scraper Racleur étroit		
682	5000010622	4	pc	Scheibe Arandela	Flat washer Rondelle		
683	5000155519	5	pc	Flanschmutter Tuerca de reborde	Flange nut Ecrou de bride	M6	DIN 1661
685	5000011341	4	pc	Sechskantschraube Tornillo hexagonal	Hexagonal head cap screw Vis à tête hexagonale	M8 x 40 25Nm/18ft.lbs	DIN931
694	5000011524	12	pc	Sechskantschraube Tornillo hexagonal	Hexagonal head cap screw Vis à tête hexagonale	M16 x 25 210Nm/155ft.lbs	DIN933
694	5000012382	12	pc	Zylinderschraube Tornillo cilíndrico	Socket head cap screw Vis à tête cylindrique	M10 x 30 83Nm/61ft.lbs	
702	5000012361	2	pc	Sechskantschraube Tornillo hexagonal	Hexagonal head cap screw Vis à tête hexagonale	M8 x 16 25Nm/18ft.lbs	
704	5000013002	6	pc	Sechskantschraube Tornillo hexagonal	Hexagonal head cap screw Vis à tête hexagonale	M12 x 25 86Nm/63ft.lbs	DIN933
709	5000017087	3	pc	Zylinderschraube Tornillo cilíndrico	Socket head cap screw Vis à tête cylindrique	M12 x 30 86Nm/63ft.lbs	ISO4762
718	5000031565	10	pc	Spannscheibe Arandela elástica	Lockwasher Rondelle de ressort	12	DIN6796
719	5000031826	6	pc	Schraube Tornillo	Screw Vis	M16 x 16 210Nm/155ft.lbs	
761	5000011380	6	pc	Sechskantschraube Tornillo hexagonal	Hexagonal head cap screw Boulon à tête hexagonale	M16 x 80 210Nm/155ft.lbs	DIN 931
790	5200009076	6	pc	Scheibe Arandela	Washer Rondelle	M16	
1413	5200007070	4	pc	Bandage-Abstreifer Kpl. Barra raspadora-ancho compl.	Wide scraper cpl. Racleur large compl.		
1414	5200007073	4	pc	Bandage-Schmal Kpl. Barra raspadora-angosto compl.	Narrow scraper cpl. Racleur étroit compl		

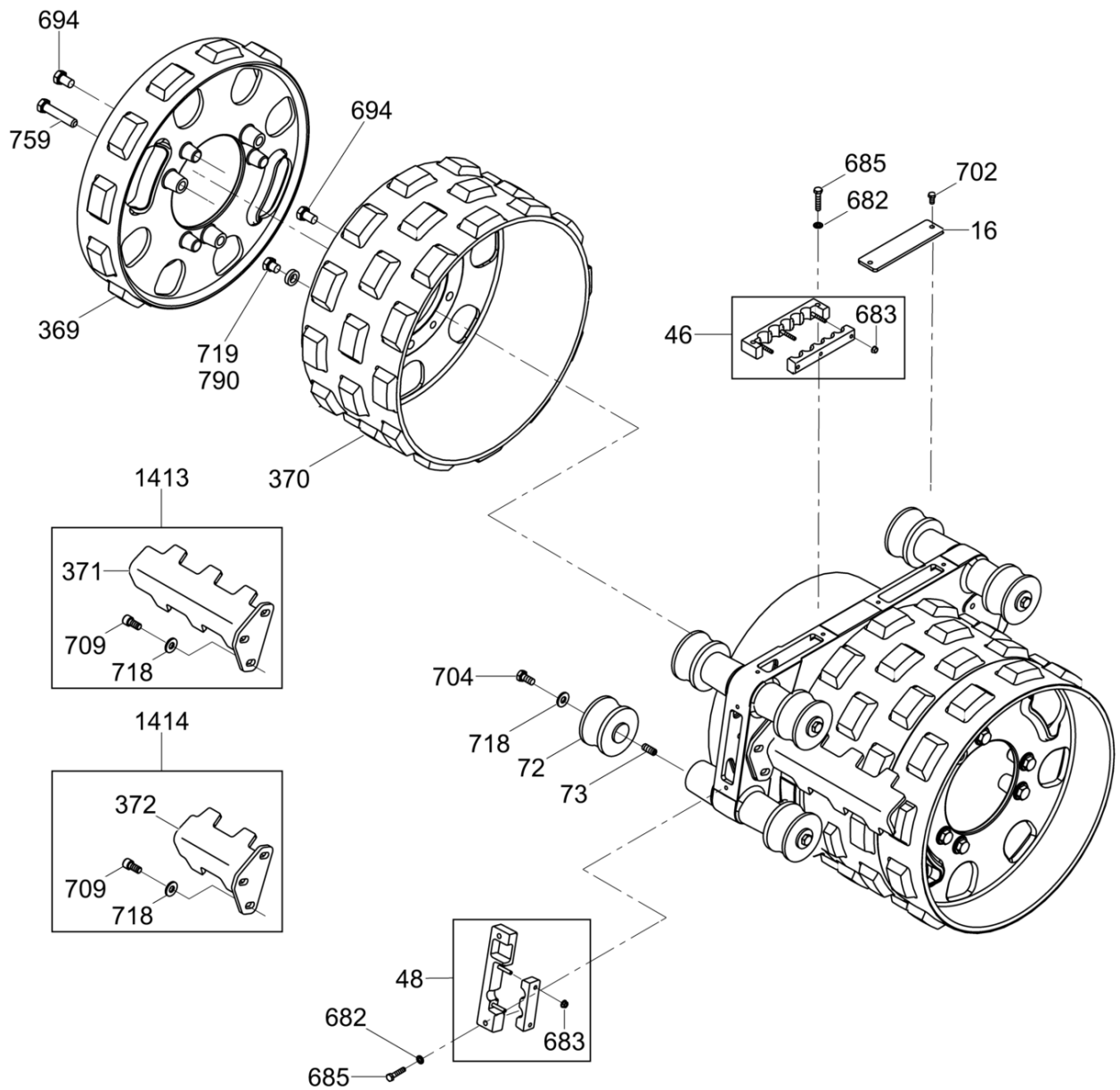

5200025158_02

Pos. Ref.	Artikel Nr. Part No.	Qty.	Unit	Beschreibung Description	Description Description	Abm. Measur.	Norm Standard
						Drehm. Torque	Schmierstoff Sealant
16	5000150306	1	pc	Platte Placa	Plate Plaque		
46	5200020388	1	pc	Schellensatz Juego de abrazaderas	Clamp set Jeu-agrafes		
48	5100036426	1	pc	Schellensatz Juego de abrazaderas	Clamp set Jeu-agrafes		
72	5002004814	6	pc	Gimmetall-Kerblager Mit Bund Amortiguador	Shockmount Silentbloc	100 x 58	
73	5000180963	6	pc	Gewindestift Tornillo	Setscrew Vis	M12 x 35	
369	5200003694	2	pc	Bandageverlängerung Tambor de extensión	Drum extension Extension de tambour		
370	5200009074	2	pc	Bandage-Schmal Tambor-angosto	Narrow drum Tambour étroit		
371	5200007069	1	pc	Bandage-Abstreifer Barra raspadora-ancho	Wide scraper Racleur large		
372	5200007072	1	pc	Bandage-Schmal Barra raspadora-angosto	Narrow scraper Racleur étroit		
678	5000010624	2	pc	Scheibe Arandela	Flat washer Rondelle		
682	5000010622	5	pc	Scheibe Arandela	Flat washer Rondelle		
683	5000155519	5	pc	Flanschmutter Tuerca de reborde	Flange nut Ecrou de bride	M6	DIN 1661
685	5000011341	4	pc	Sechskantschraube Tornillo hexagonal	Hexagonal head cap screw Vis à tête hexagonale	M8 x 40 25Nm/18ft.lbs	DIN931
694	5000011524	12	pc	Sechskantschraube Tornillo hexagonal	Hexagonal head cap screw Vis à tête hexagonale	M16 x 25 210Nm/155ft.lbs	DIN933
702	5000012361	2	pc	Sechskantschraube Tornillo hexagonal	Hexagonal head cap screw Vis à tête hexagonale	M8 x 16 25Nm/18ft.lbs	
704	5000013002	6	pc	Sechskantschraube Tornillo hexagonal	Hexagonal head cap screw Vis à tête hexagonale	M12 x 25 86Nm/63ft.lbs	DIN933
709	5000017087	3	pc	Zylinderschraube Tornillo cilíndrico	Socket head cap screw Vis à tête cylindrique	M12 x 30 86Nm/63ft.lbs	ISO4762
718	5000031565	10	pc	Spannscheibe Arandela elástica	Lockwasher Rondelle de ressort	12	DIN6796
719	5000031826	6	pc	Schraube Tornillo	Screw Vis	M16 x 16 210Nm/155ft.lbs	
759	5000011380	6	pc	Sechskantschraube Tornillo hexagonal	Hexagonal head cap screw Boulon à tête hexagonale	M16 x 80 210Nm/155ft.lbs	DIN 931
779	5000011456	2	pc	Sechskantschraube Tornillo hexagonal	Hexagonal head cap screw Vis à tête hexagonale		
790	5200009076	6	pc	Scheibe Arandela	Washer Rondelle	M16	
1413	5200007070	4	pc	Bandage-Abstreifer Kpl. Barra raspadora-ancho compl.	Wide scraper cpl. Racleur large compl.		
1414	5200007073	4	pc	Bandage-Schmal Kpl. Barra raspadora-angosto compl.	Narrow scraper cpl. Racleur étroit compl.		

Erreger Kpl.
Exciter cpl.
Excitador compl.
Excitatrice compl.

RTKx-SC3

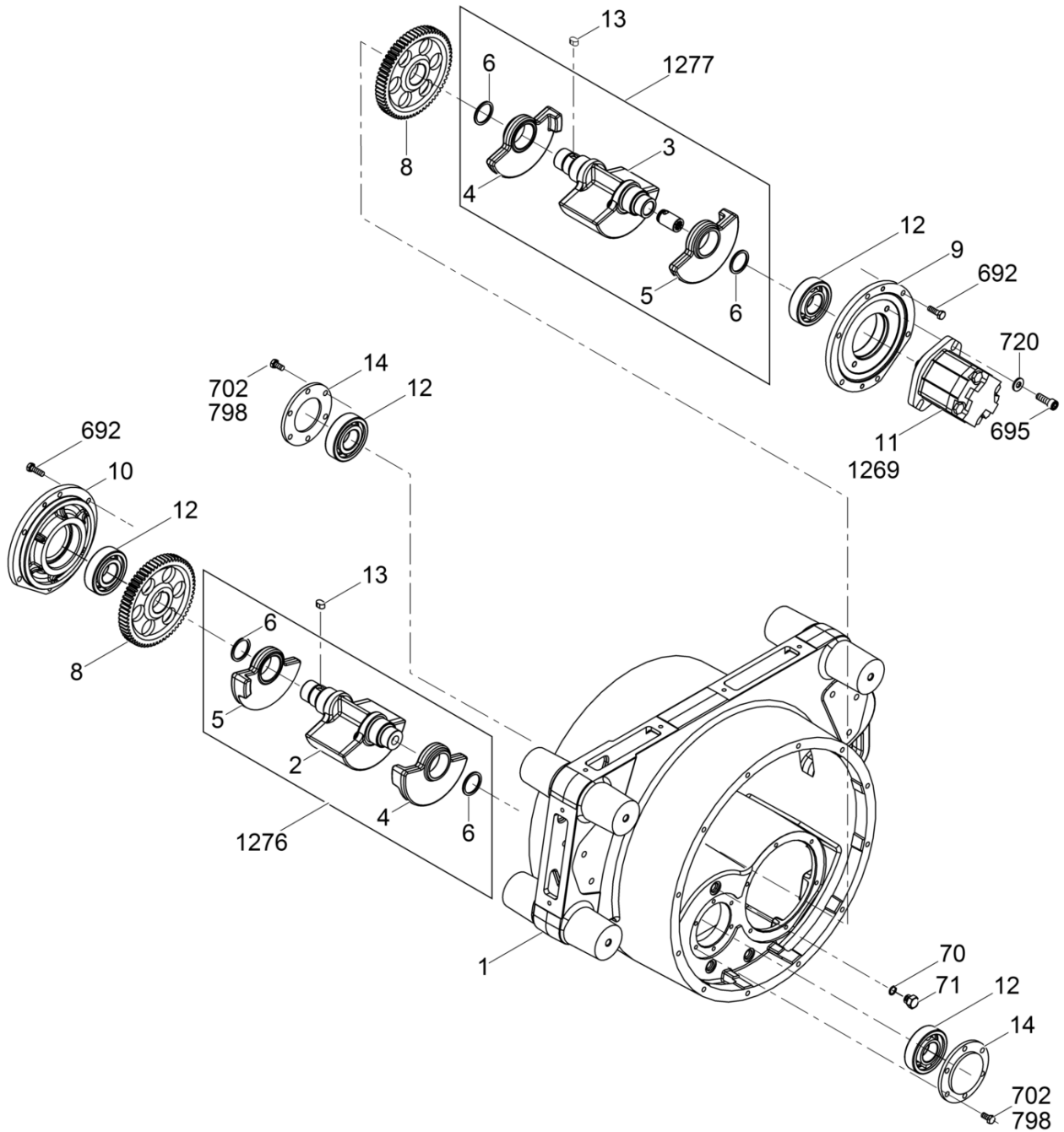

200_5200019255100015

Pos. Ref.	Artikel Nr. Part No.	Qty.	Unit	Beschreibung Description	Description Description	Abm. Measur.	Norm Standard
						Drehm. Torque	Schmierstoff Sealant
1	5000116902	1	pc	Bandagenträger Soporte del tambor	Drum support Support de tambour		
2	5000171032	2	pc	Erregerwelle Ohne Senkung Eje del excitador s/escariador	Exciter shaft w/o counterbore Arbre de l'excitatrice sans lo		
3	5000171033	2	pc	Erregerwelle Mit Senkung Eje del excitador c/escariador	Exciter shaft w/counterbore Arbre de l'excitatrice avec lo		
4	5000171034	4	pc	Unwucht Masa excéntrica	Eccentric weight Balourd excentrique		
5	5000171035	4	pc	Unwucht Masa excéntrica	Eccentric weight Balourd excentrique		
6	5000171028	8	pc	Sicherungsring Anillo de retención	Retaining ring Bague d'arrêt	45 x 1,69in	
8	5200001515	2	pc	Zahnrad (Composite) Engranaje (compuesto)	Gear (composite) Engrenage (composite)		
9	5000116958	1	pc	Deckel Tapa	Cover Couvercle		
10	5000116959	1	pc	Lagerdeckel Tapa del rodamiento	Bearing cover Tapa del rodamiento		
11	5000182917	1	pc	Erregermotor Motor excitador	Exciter motor Moteur d'excitatrice		
12	5000080742	4	pc	Rollenlager Rodamiento de rodillos	Roller bearing Roulement à rouleaux		
13	5000115699	2	pc	Passfeder Chaveta	Square key Clavette	A10 x 8 x 16	DIN6885
14	5000171000	4	pc	Deckel Tapa	Cover Couvercle		
70	5000014398	3	pc	O-Ring Anillo-o	O-ring Joint torique	12 x 2	
71	5000078269	3	pc	Schraubverschluß Tapón roscado	Plug (threaded) Bouchon	9/16-18in	
692	5000011457	12	pc	Sechskantschraube Tornillo hexagonal	Hexagonal head cap screw Vis à tête hexagonale	M8 x 25 25Nm/18ft.lbs	
695	5000011534	2	pc	Zylinderschraube Tornillo cilíndrico	Cheese head screw Vis à tête cylindrique	M10 x 30 49Nm/36ft.lbs	ISO4762
702	5000012361	12	pc	Sechskantschraube Tornillo hexagonal	Hexagonal head cap screw Vis à tête hexagonale	M8 x 16 25Nm/18ft.lbs	
720	5000033988	2	pc	Spannscheibe Arandela elástica	Lockwasher Rondelle de ressort	10	DIN6796
798	5000172326	24	pc	Scheibe Arandela elástica	Flat washer Rondelle de ressort	8.4	
1269	5200024514	1	pc	Dichtungssatz Juego-empaque	Seal kit Jeu-joint		
1276	5000171445	2	pc	Erregerwellensatz Ohne Senkung Juego-eje del excitador s/ escariador	Exciter shaft kit w/o counterbore Jeu-arbre de l'excitatrice san escariador		
1277	5000171446	2	pc	Erregerwellensatz Mit Senkung Juego-eje del excitador c/ escariador	Exciter shaft kit w/counterbore Jeu-arbre de l'excitatrice ave escariador		

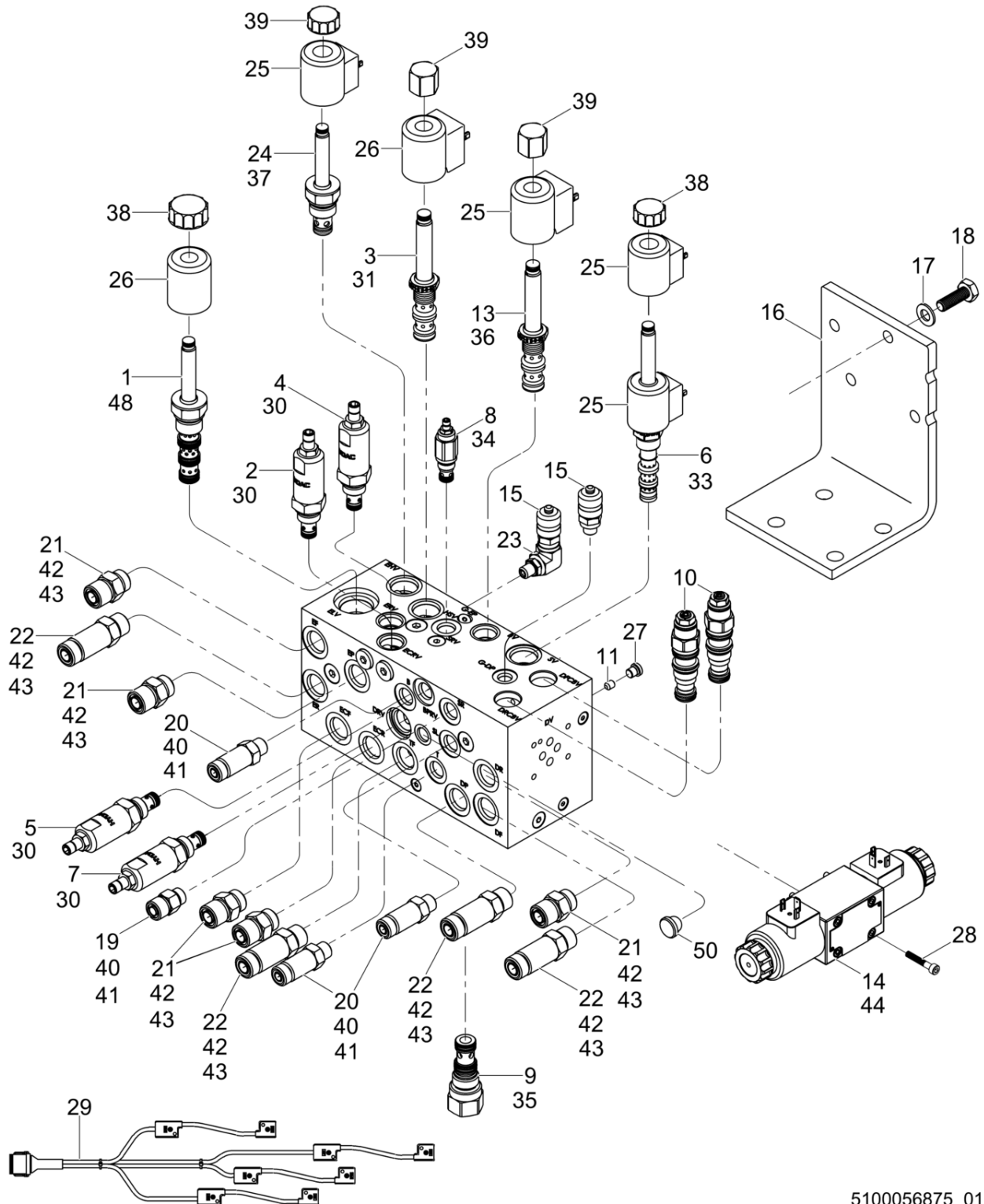

5100056875_01

Pos. Ref.	Artikel Nr. Part No.	Qty.	Unit	Beschreibung Descripción	Description Description	Abm. Measur.	Norm Standard
						Drehm. Torque	Schmierstoff Sealant
1	5100016775	1	pc	Ventil-Solenoid Válvula-solenoide	Solenoid valve Électrovanne		
2	5100016776	1	pc	Überdruckventil Válvula de desahoga	Relief valve Soupape de surpression		
3	5100016777	1	pc	Ventil-Solenoid Válvula-solenoide	Solenoid valve Électrovanne		
4	5100016778	1	pc	Überdruckventil Válvula de desahoga	Relief valve Soupape de surpression		
5	5100050074	1	pc	Überdruckventil Válvula de desahoga	Relief valve Soupape de surpression		
6	5100016780	1	pc	Steuerventil Válvula de dirección	Steering valve Soupape de direction		
7	5100016781	1	pc	Überdruckventil Válvula de desahoga	Relief valve Soupape de surpression		
8	5100016782	1	pc	Steuerventil Válvula de dirección	Steering valve Soupape de direction		
9	5100016783	1	pc	Bypassventil Válvula de desviador	Bypass valve Soupape de dérivation		
10	5100016784	2	pc	Ausgleichsventil Válvula de compensación	Counterbalance valve Soupape de contrecharge		
11	5100016785	1	pc	Gewindestift Tornillo	Setscrew Vis	2,70	
12	5100016786	1	pc	Gewindestift Tornillo	Setscrew Vis	0,80	
13	5100016787	1	pc	Bremsventil Válvula de frenaje	Brake valve Robinet de freinage		
14	5100046563	1	pc	Antriebsventil Válvula de mando	Drive valve Soupape d'entraînement		
15	5000182738	2	pc	Prüfverschraubung Mit Kappe Unión de prueba con tapa	Test fitting w/cap Raccord d'essai avec couvercle	M16 x 2, 7/16-20 UNC	
16	5100016789	1	pc	Konsole Ménsula	Mounting bracket Support		
17	5000010621	3	pc	Scheibe Arandela	Washer Rondelle		
18	5200015174	4	pc	Schraube Tornillo	Screw Vis		
19	5000078816	1	pc	Zwischenverschraubung Unión con adaptador	Adapter fitting Raccord intermédiaire		
20	5000158574	3	pc	Verschraubung Unión	Fitting Raccord	No.6	
21	5000080558	6	pc	Verschraubung Unión	Fitting Raccord		
22	5000158572	3	pc	Verschraubung Unión	Fitting Raccord	No.8	
23	5100016790	1	pc	Hydraulikverschraubung Unión hidráulico	Hydraulic fitting Raccord hydraulique	4 x 4	
24	5100016791	1	pc	Erregung Des Ventils Excitador de válvula	Exciter valve Excitation de valve		
25	5100016792	4	pc	Spule Bobina	Coil Bobine	12V	
26	5100016793	2	pc	Spule Bobina	Coil Bobine	12V	
27	5100016794	9	pc	Stopfen Tapón	Plug Bouchon	No. 2	
28	5000011558	4	pc	Zylinderschraube Tornillo cilíndrico	Cheese head screw Vis à tête cylindrique	M5 x 30 10Nm/7ft.lbs	ISO4762

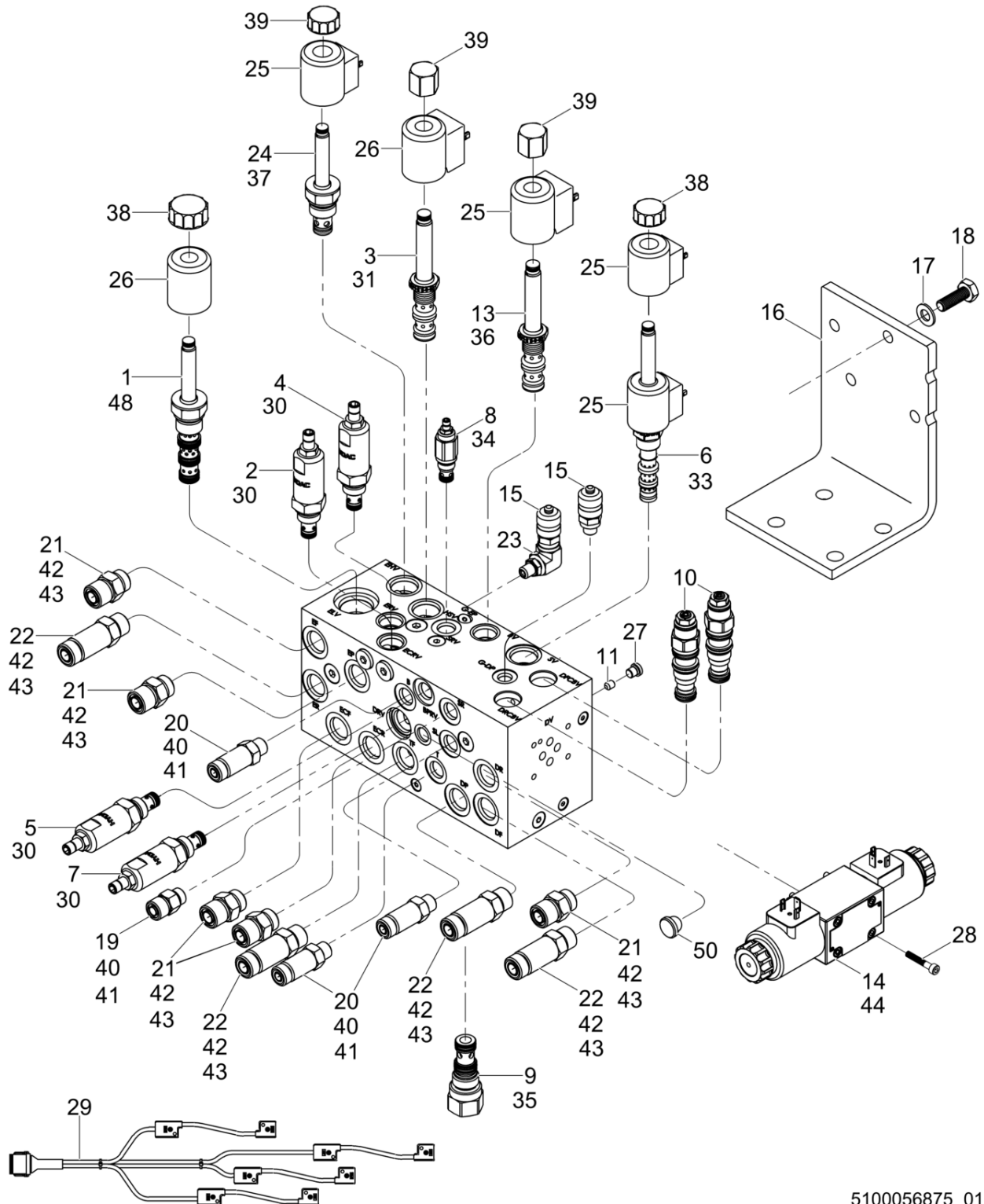

5100056875_01

Pos. Ref.	Artikel Nr. Part No.	Qty.	Unit	Beschreibung Description	Description Description	Abm. Measur.	Norm Standard
						Drehm. Torque	Schmierstoff Sealant
29	5100050073	1	pc	Kabelbaum Conjunto de cables	Wiring harness Harnais de câbles électriques		
30	5100016796	3	pc	Dichtungssatz Juego-empaque	Seal kit Jeu-joint		
31	5100016797	1	pc	Dichtungssatz Juego-empaque	Seal kit Jeu-joint		
32	5100016798	1	pc	Dichtungssatz Juego-empaque	Seal kit Jeu-joint		
33	5100016799	1	pc	Dichtungssatz Juego-empaque	Seal kit Jeu-joint		
34	5100016800	1	pc	Dichtungssatz Juego-empaque	Seal kit Jeu-joint		
35	5100016801	1	pc	Dichtungssatz Juego-empaque	Seal kit Jeu-joint		
36	5100016802	1	pc	Dichtungssatz Juego-empaque	Seal kit Jeu-joint		
37	5100016803	1	pc	Dichtungssatz Juego-empaque	Seal kit Jeu-joint		
38	5100016804	2	pc	Spule Kpl. Bobina compl.	Coil kit Bobine compl.		
39	5100016805	3	pc	Ventilkappe Bobina compl.	Coil kit Bobine compl.		
40	5000080731	4	pc	O-Ring Anillo-o	O-ring Joint torique	0,47 x 0,07in #6	
41	5000080736	4	pc	O-Ring Anillo-o	O-ring Joint torique	0,36 x 0,07in #6 ORFS	
42	5000080732	9	pc	O-Ring Anillo-o	O-ring Joint torique	0,64 x 0,09in #8	
43	5000080737	9	pc	O-Ring Anillo-o	O-ring Joint torique	0,49 x 0,07in #8 ORFS	
44	5100016873	1	pc	Dichtungssatz Juego-empaque	Seal kit Jeu-joint		
48	5100016795	1	pc	Dichtungssatz Juego-empaque	Seal kit Jeu-joint		
50	5100056876	1	pc	Sieb Tamizador	Strainer Tamis		

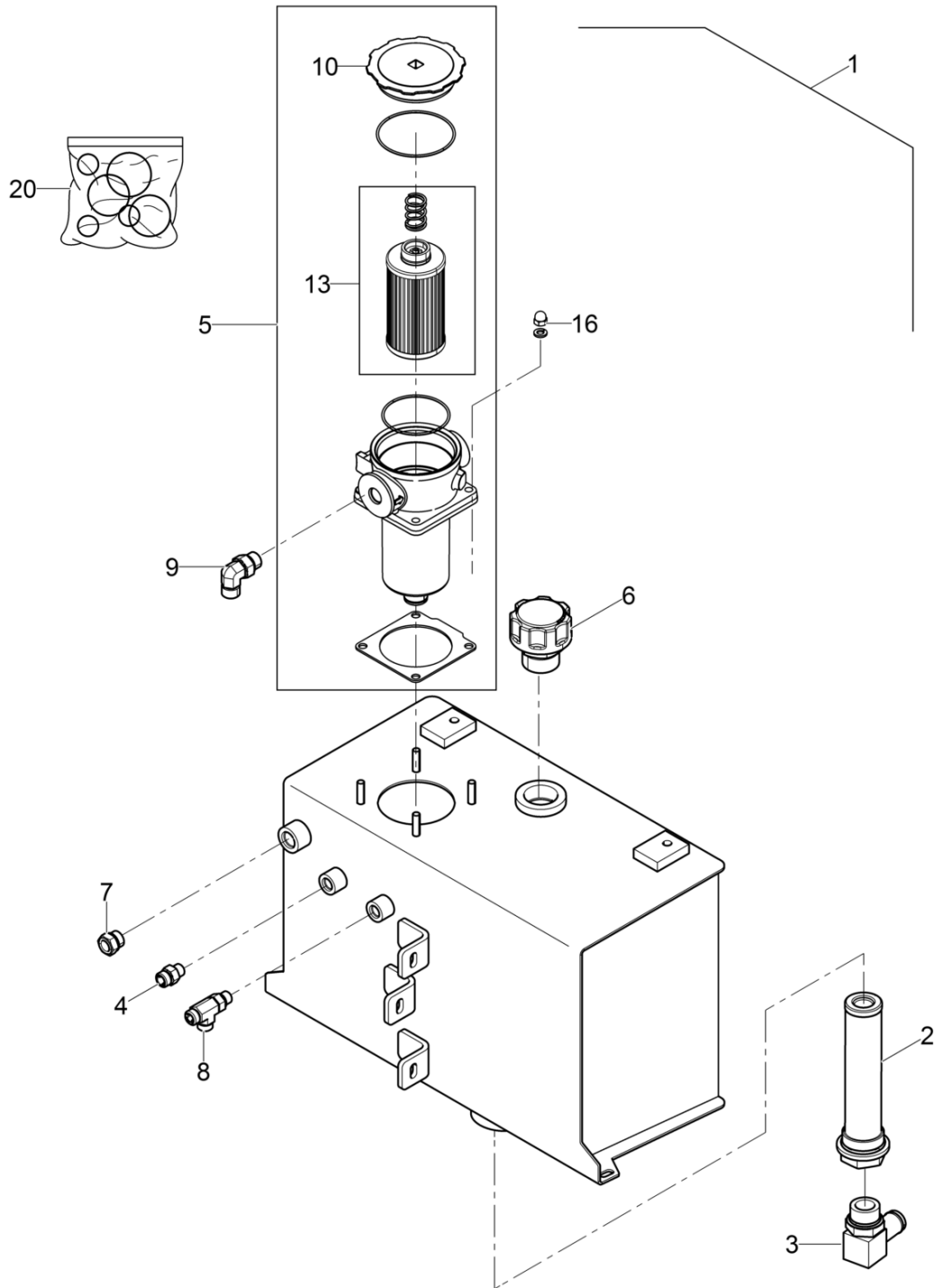

200_5200000844001001

Pos. Ref.	Artikel Nr. Part No.	Qty.	Unit	Beschreibung Descripción	Description Description	Abm. Measur.	Norm Standard
						Drehm. Torque	Schmierstoff Sealant
1	5200000844	1	pc	Hydrauliktank Tanque hidráulico	Hydraulic tank Réservoir hydraulique		
2	5000182746	1	pc	Saugkorb Colador	Suction strainer Crépine		
3	5000182747	1	pc	Verschraubung Mit Widerhaken Unión dentada	Barbed fitting Raccord à picot	No.6 x 90	
4	5000078816	1	pc	Zwischenverschraubung Unión con adaptador	Adapter fitting Raccord intermédiaire		
5	5000182748	1	pc	Rückleitungsfilter Filtro de retorno	Return filter Filtre de retour		
6	5200000845	1	pc	Entlüftungskappe Tapa respiradero	Breather tube Capuchon reniflard		
7	5000116236	1	pc	Ölschauglas Mirilla del nivel de aceite	Sightglass Verre-regard d'huile		
8	5000083412	1	pc	Verschraubung Unión	Fitting Raccord		
9	5000111272	1	pc	Hydraulikrohrkrümmer Codo hidráulico	Hydraulic elbow fitting Coude hydraulique	SAE No.8 x 90	
10	5000182750	1	pc	Deckel Tapa	Cover Couvercle		
13	5000182752	1	pc	Filterelement Elemento del filtro	Filter element Élément du filtre		
16	5000159508	4	pc	Hutmutter Tuerca	Acorn nut Ecrou	M10	
20	5000182733	1	pc	Dichtungs- U. O-Ringsatz Juego de juntas/anillos-o	Gasket & o-ring set Jeu de joints		

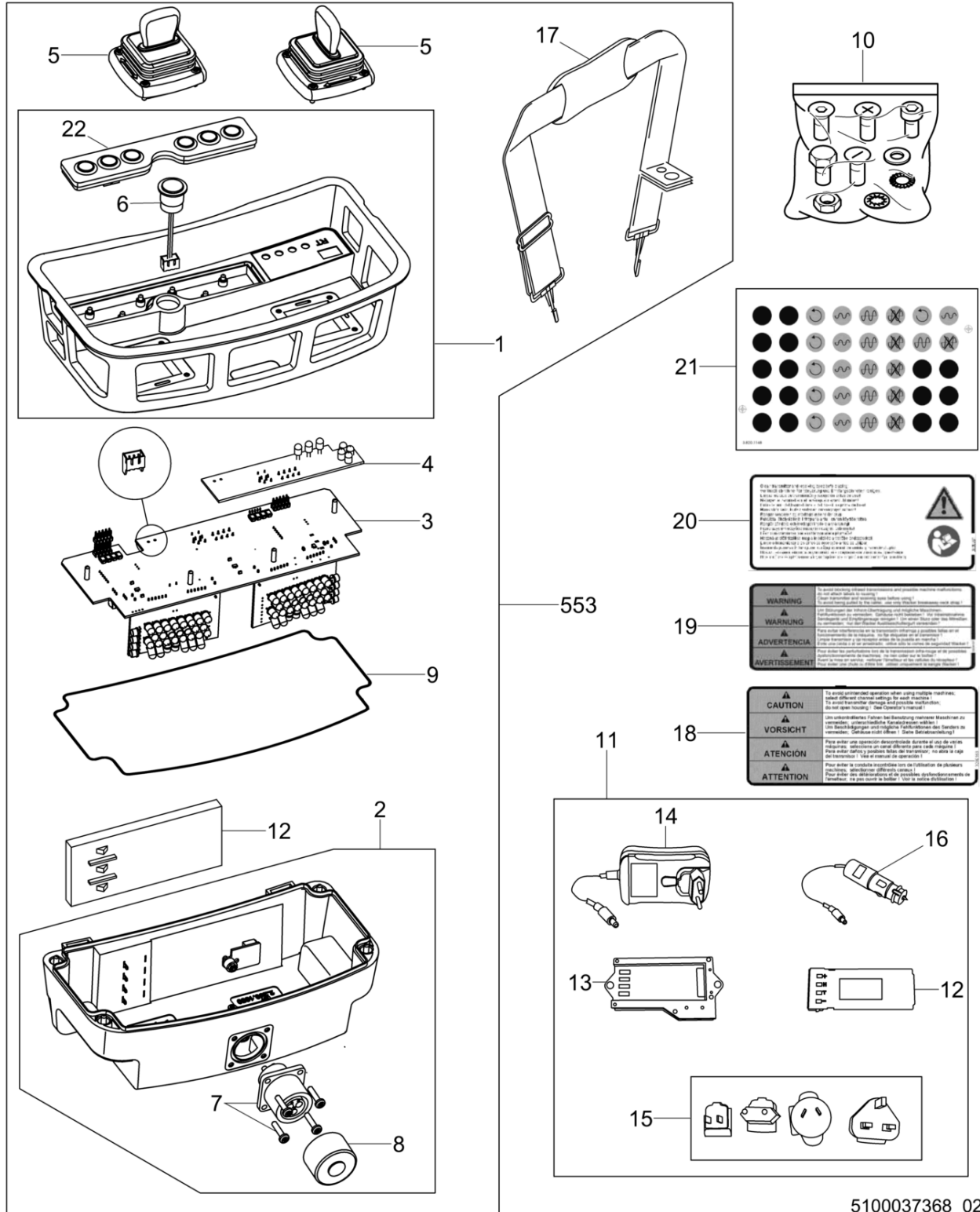

Pos. Ref.	Artikel Nr. Part No.	Qty.	Unit	Beschreibung Description	Description Description	Abm. Measur.	Norm Standard
						Drehm. Torque	Schmierstoff Sealant
1	5100029414	1	pc	Oberer Rahmen Chasis superior	Upper housing Châssis supérieur		
2	5000180315	1	pc	Untere Umhüllung Envoltura inferior	Lower housing Gaine inférieure		
3	5100044531	1	pc	Schaltplatte Tablero de circuitos	Circuit board Carte de circuit		
4	5000180317	1	pc	Leiterplatte Presentación de tablero de circuitos	Circuit board display Affichage de carte de circuit		
5	5000177083	2	pc	Steuerhebel-Satz Palanca de dirección-juego	Steering lever kit Lever de direction-jeu		
6	5100044532	1	pc	Schalter, Ein/Aus Interruptor, enc./apag.	On/off switch Interrupteur, marche/arrêt		
7	5100037365	1	pc	3-Polige Buchse Socket 3-pin	3-pin connector 3 broches		
8	5000117184	1	pc	Kappe Tapa	Cap Couvercle		
9	5000164704	1	pc	Dichtung Empaque	Seal Joint		
10	5000180320	1	pc	Kleinteilesatz Juego de piezas pequeñas	Hardware kit Jeu de pièces		
11	5000213091	1	pc	Ladegerät Juego de carga	Charging set Jeu de charge		
12	5000210156	1	pc	Akku Batería	Battery Accumalteur		
13	5000209760	1	pc	Ladegerät Cargador par batería	Battery charger Chargeur de batteries		
14	5000209761	1	pc	Steckernetzteil Enchufe de alimentación	Electrical plug Mains plug		
15	5000209762	1	pc	Steckeradapter-Set Enchufe de alimentación	Plug adapter set Mains plug		
16	5000209763	1	pc	Anschlusskabel Cable de alimentación	Power cable Cable d'alimentation		
17	5000114783	1	pc	Band Cinta	Band Ruban		
18	5000209158	1	pc	Aufkleber-Hinweis Calcomanía-indicación	Instruction label Autocollant avec indication		
19	5000209157	1	pc	Aufkleber-Warnung Calcomanía-advertencia	Label-warning Autocollant-avertissement		
20	5000226261	1	pc	Aufkleber Calcomanía	Label Autocollant		
21	5200017125	1	pc	Aufkleberblatt Hoja de calcomanias	Label sheet Feuille d'autocollants		
22	5100037750	1	pc	Plattenmodul Anschließen Módulo de placa de interruptor	Switch plate module Module de plaque d'interrupteu		
553	5000165514	1	pc	Sender Transmisor	Transmitter module Transmetteur		

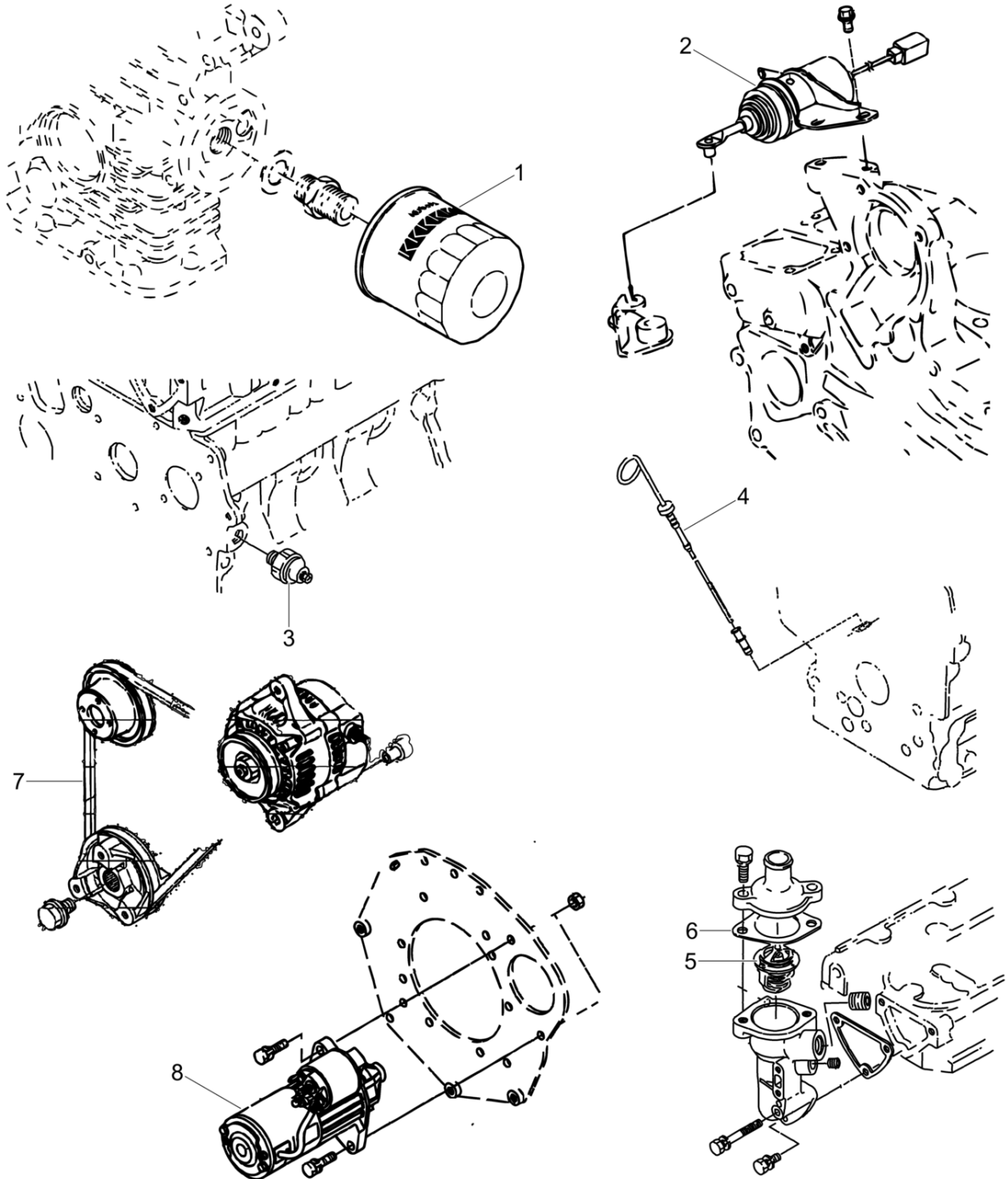

200_5200017279001001

Pos. Ref.	Artikel Nr. Part No.	Qty.	Unit	Beschreibung Descripcion	Description Description	Abm. Measur.	Norm Standard
						Drehm. Torque	Schmierstoff Sealant
1	5200004741	1	pc	Ölfilter Filtro de aceite	Oil filter Filtre d'huile		
2	5100022591	1	pc	Abstellmagnet Dejar de solenoide	Stop solenoid Arrêter solénoïde		
3	5200024858	1	pc	Öldruckschalter Interruptor de presión de aceite	Oil pressure switch Interrupteur à pression d'huile		
4	5200023778	1	pc	Peilstab Indicador del nivel de aceite	Dipstick Réglette-jauge		
5	5000176754	1	pc	Temperaturregler Termóstato	Thermostat Thermostat		
6	5000176755	1	pc	Temperaturreglerdichtung Junta del termóstato	Thermostat gasket Joint du thermostat		
7	5200004743	1	pc	Zahnriemen Correa	Belt Courroie		
8	5100027959	1	pc	Starter Kpl. Arrancador compl.	Starter cpl. Démarreur compl.		

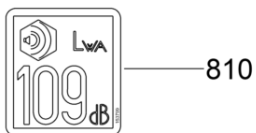
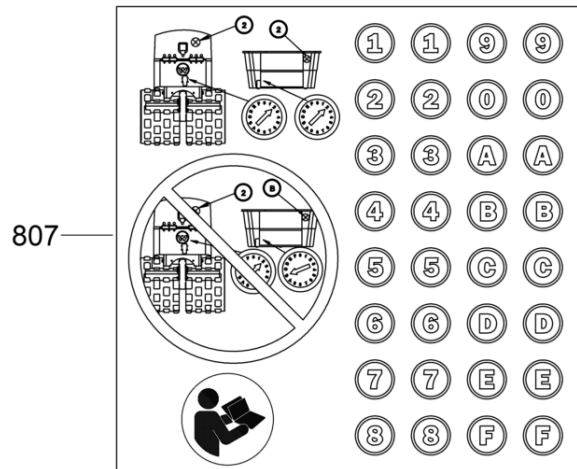
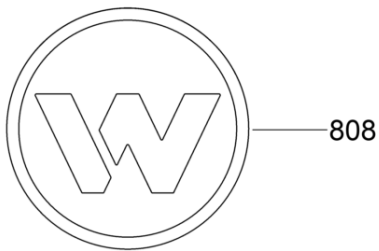
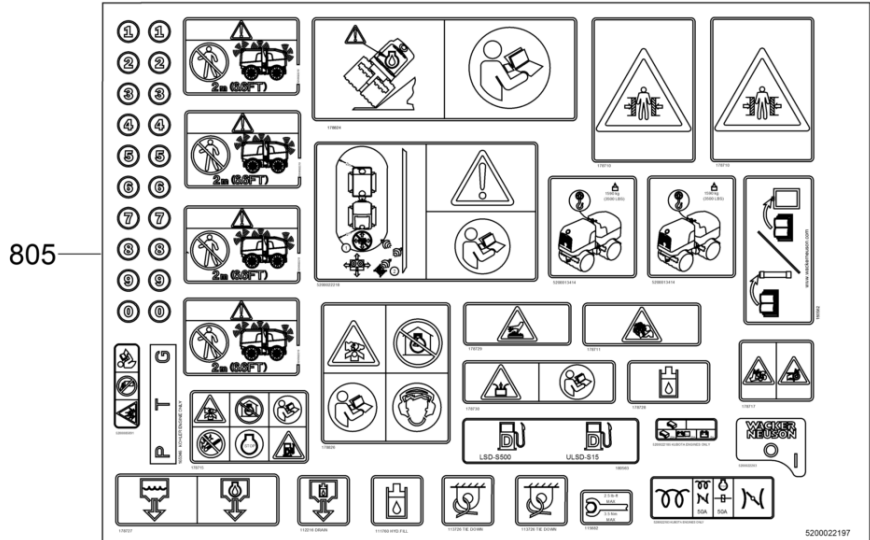

801—RTSC3

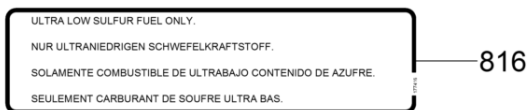

802—WACKER
NEUSON

200_5200019256100020

Pos. Ref.	Artikel Nr. Part No.	Qty.	Unit	Beschreibung Descripcion	Description Description	Abm. Measur.	Norm Standard
						Drehm. Torque	Schmierstoff Sealant
801	5200023102	2	pc	Aufkleber Calcomania	Label Autocollant		
802	5000222136	2	pc	Aufkleber, Logo Calcomanía-logotipo	Label-logo Autocollant - logo	100 OD	
805	5200022197	1	pc	Aufkleberblatt-EU Hoja de calcomanias-eu	Label sheet-eu Feuille d'autocollants-eu		
807	5000181067	1	pc	Aufkleber Calcomania	Label Autocollant		
808	5000222087	2	pc	Aufkleber Symbol Calcomania simbololo	Label symbol Autocollant symbole	120 OD	
810	5000153799	1	pc	Aufkleber Calcomania	Label Autocollant		

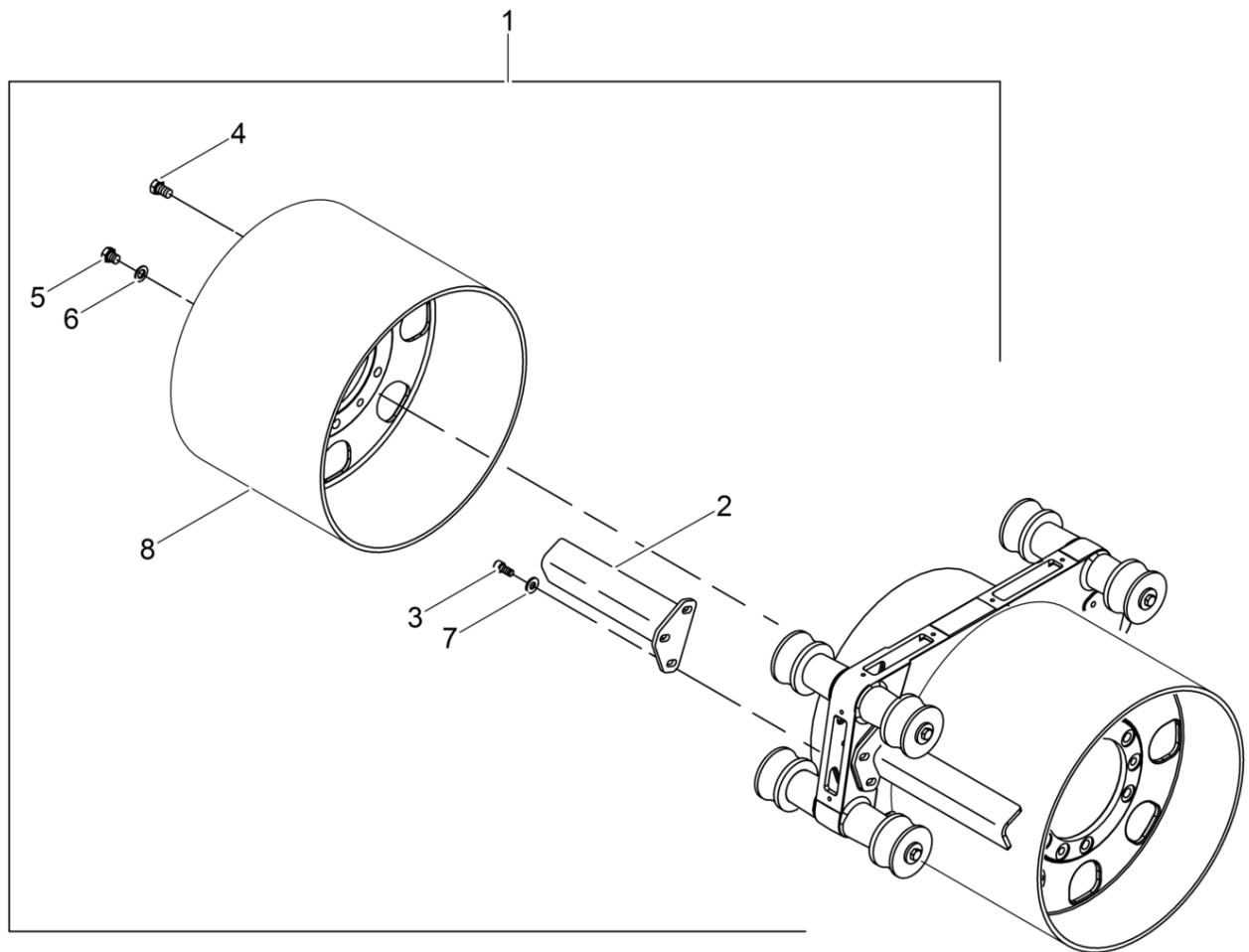

wc_ex0162787001

Pos. Ref.	Artikel Nr. Part No.	Qty.	Unit	Beschreibung Descripcion	Description Description	Abm. Measur.	Norm Standard
						Drehm. Torque	Schmierstoff Sealant
1	5000162787	1	pc	Bandagensatz Juego de tambor (plano)	Smooth drum kit Jeu de tambour (lisse)	820mm/32in	
2	5200006892	8	pc	Bandage-Abstreifer Barra raspadora-ancho	Wide scraper Racleur large		
3	5000017087	24	pc	Zylinderschraube Tornillo cilíndrico	Socket head cap screw Vis à tête cylindrique	M12 x 30 86Nm/63ft.lbs	ISO4762
4	5000011542	24	pc	Zylinderschraube Tornillo cilíndrico	Cheese head screw Vis à tête cylindrique	202Nm/149ft.lbs	
5	5000031826	12	pc	Schraube Tornillo	Screw Vis	M16 x 16 202Nm/149ft.lbs	
6	5000010618	24	pc	Scheibe Arandela	Flat washer Rondelle	16	DIN125-1
7	5000031565	24	pc	Spannscheibe Arandela elástica	Lockwasher Rondelle de ressort	12	DIN6796
8	5000171665	4	pc	Bandage (Glatt) Tambor (plano)	Smooth drum Tambour (lisse)	820	



**WACKER
NEUSON**

