



**WACKER
NEUSON**

Catalogo ricambi
Catálogo de piezas de repuesto
Spare parts catalog

**Roller
Rodillos
Roller**

**RC50p DPF
ROPS**



Type	RC50p DPF ROPS
Material Number	5100064258
Version	100
Language	it es en



www.wackerneuson.com

Copyright © 01.2023
Wacker Neuson Produktion GmbH & Co. KG
Printed in Germany.
All rights reserved.

Informazioni generali sul catalogo dei pezzi di ricambio

Informazioni generali

In fase di ordinazione dei ricambi, va fatta attenzione affinché i dati della macchina siano completi.

Tra questi rientrano la denominazione di vendita della macchina, il numero di serie, nonché l'anno di costruzione. In caso di ordinazione di parti di motore o assi, sono inoltre necessari il tipo e il numero di serie dei componenti.

Inoltre, sono necessari i seguenti dati: codice materiale e codice posizione.

Il numero di serie si trova nel telaio della macchina. Esso si trova anche sulla targhetta del modello. Il numero di serie deve essere indicato nella sua completezza.

La macchina in copertina può presentare allestimenti speciali (AS/Accessori). La rappresentazione non è vincolante per la versione.

Il numero di ricambi indicato nel catalogo dei ricambi si riferisce alle unità indicate in questo disegno.

In questo catalogo ricambi sono rappresentate tutte le opzioni disponibili da fabbrica per questa macchina. Per questo motivo è anche possibile che siano rappresentate AS di cui la macchina non è dotata. Non tutte le AS raffigurate sono disponibili in tutti i paesi/in tutte le regioni.

AS/accessori possono essere aggiunti in un secondo momento. Non tutte le opzioni sono combinabili tra loro.

In alcuni casi vengono raffigurati anche componenti non disponibili come ricambi. Questi componenti non sono posizionati sui disegni. La raffigurazione serve esclusivamente a scopo di comprensione e non genera alcun diritto sul componente raffigurato.

Le indicazioni "a sinistra" e "a destra" della descrizione o nell'informazione si riferiscono sempre alla macchina nella direzione di marcia.

Nell'ambito del perfezionamento tecnico, lavoriamo costantemente al miglioramento e all'ottimizzazione dei nostri prodotti. Per questo motivo è possibile, che le illustrazioni nel catalogo ricambi possono discostarsi dall'aspetto reale.

Il costruttore si riserva il diritto di modifiche non annunciate sui ricambi, in qualsiasi momento. Questo vale sia per la quantità di ricambi indicata, che per la versione tecnica. Per ricevere le informazioni più attuali sulla macchina, cerchiamo di metterci in contatto con un concessionario.

Dati tecnici, dimensioni e pesi non sono vincolanti e corrispondono allo stato al momento della stampa. Con riserva di errori.

Modifiche tecniche non autorizzate sulla macchina comportano una sostanziale riduzione della sicurezza operativa.

La sicurezza operativa viene garantita mediante l'utilizzo dei ricambi originali e di moduli/accessori abilitati.

Il costruttore non si assume alcuna responsabilità per danni causati per via di modifiche tecniche non autorizzate oppure per l'omissione di ricambi originali.

Tabella di conversione

Volume	
1 ml	0.034 US fl.oz.
1 l	0.260 gal
Lunghezze	
1 mm	0.039 in
1 m	3.280 ft
Peso	
1 kg	2.200 lbs
1 g	0.035 oz
Velocità	
1 km/h	0.620 mph
Momento torcente	
1 Nm	0.740 ft.lbs



Informazioni generali sul catalogo dei pezzi di ricambio

Configurazione

1. Descrizione dell'unità/della pagina del catalogo ricambi
2. Informazioni dettagliate (Information) sulla corrispondente unità/la pagina di catalogo ricambi oppure codice materiale. Esse possono contenere:
 - < WXXXXXXXXX1234567 oppure A: WXXXXXXXXX1234567: validità fino a numero di serie
 - > WXXXXXXXXX1234568 oppure E: WXXXXXXXXX1234568: validità da numero di serie
 - Opzione: questo materiale è necessario solo per una determinata opzione
 - e molto altro.
3. Superficie illustrata: qui vengono raffigurati i ricambi presenti nell'unità.
4. Più ricambi in un telaio/oppure una parentesi rappresenta un set/kit. In caso di ordinazione dei corrispondenti codici posizione, vengono spediti tutti i ricambi che vi si trovano all'interno.
5. Numero dell'unità. Attenzione! Questo numero non è ordinabile!
6. Denominazione di vendita della macchina ovvero numero di materiale di vendita - Versione
7. Indicazione della pagina
8. Codice posizione (Ref.)
9. Lotto numero (Part No.)
10. Descrizione materiale
11. Quantità montata (Qty.)
12. Unità quantitativa (Unit)
13. Facoltativo: qui viene raffigurata la corrispondente opzioni con l'aiuto di un pittogramma.

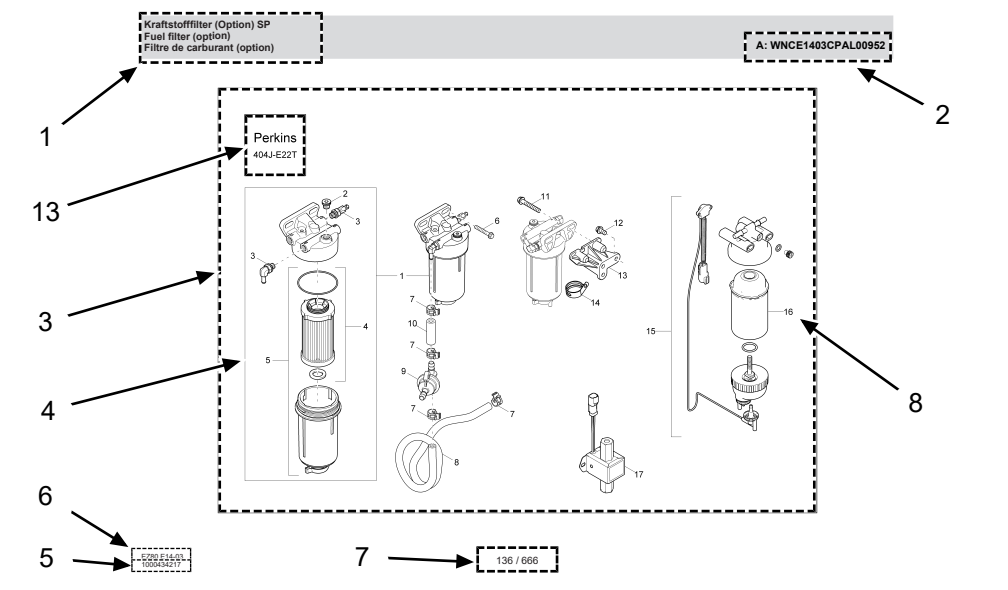

Kraftstofffilter (Option) SP						A: WNCE1403CPAL00952	
Fuel filter (option)							
Filtre de carburant (option)							
Ref.	Part No.	Beschreibung	Description	Description	Information	Qty.	Unit
1	1000386655	Kraftstofffilter	Fuel filter	Filtre de carburant		1	pc
2	1000389249	Stopfen	Plug	Bouchon		1	pc
3	1000389229	Verschraubung	Screw joint	Raccord		2	pc
4	1000386656	Filtereinsatz	Filter insert	Cartouche filtrante		1	pc
5	1000433955	Filtergehäuse	Filter housing	Bolle de filtre		1	pc
6	1000139973	Schraube	Screw	Vis		1	pc
7	1000389241	Schlauchschelle	Hose clamp	Bride de fixation flexible		4	pc
8	1000389247	Kraftstoffschlauch	Fuel line	Tuyau flexible de combustible		1	pc
9	1000434006	Druckbegrenzungsventil	Pressure limit reliefvalve	Soupape limitrice de pression		1	pc
10	1000389230	Kraftstoffschlauch	Fuel line	Tuyau flexible de combustible		1	pc
11	1000139973	Schraube	Screw	Vis		1	pc
12	1000083888	Schraube	Screw	Vis		3	pc
13	1000433952	Arm	Arm	Bras		1	pc
14	1000328508	Klammer	Clamp	Attache		1	pc
15	1000433949	Kraftstofffilter	Fuel filter	Filtre de carburant		1	pc
16	1000433950	Kraftstofffilter	Fuel filter	Filtre de carburant		1	pc
17	1000389262	Kraftstoffpumpe	Fuel pump	Pompe de remplissage	A: WNCE1403CPAL00952	1	pc



Información general sobre el libro de repuestos

Consideraciones generales

Al realizar un pedido de repuestos, debe asegurarse de que todos los datos de la máquina estén completos.

Estos incluyen la denominación de ventas de la máquina, el número de serie y también el año de fabricación. En el caso de pedidos de piezas del motor o del eje, se requieren también el tipo y el número de serie de los componentes.

Se requieren, asimismo, los siguientes datos: número de material y número de ítem.

El número de serie puede verse en el chasis de la máquina. Se encuentra, además, sobre la placa de identificación. Asimismo, el número de serie debe indicarse por completo.

La máquina que figura en la portada puede mostrar equipamientos especiales (opciones/accesorios). La representación no es determinante para el modelo.

La cifra de los repuestos indicada en el catálogo de repuestos se vincula con el módulo mostrado en este dibujo.

En este catálogo de repuestos se muestran todas las opciones que pueden obtenerse de fábrica para la máquina. Por este motivo, pueden mostrarse también opciones con las que la máquina no esté equipada. No todas las opciones mostradas se encuentran disponibles en todos los países/regiones.

Las opciones/accesorios pueden, en parte, instalarse con posterioridad. No todas las opciones pueden combinarse entre sí.

En muchos casos se muestran también componentes que no pueden obtenerse como repuestos. Estos componentes no están posicionados en los dibujos. La representación solo tiene el propósito de facilitar la comprensión y no crea derecho alguno sobre el componente mostrado.

Las indicaciones «izquierdo/a» y «derecho/a» de la descripción o de la información se refieren siempre a la máquina en dirección de marcha hacia delante.

En el curso de nuestra innovación técnica, trabajamos constantemente para mejorar y optimizar nuestros productos. Por tal motivo, es posible que haya imágenes en el catálogo de repuestos que varíen en comparación con su diseño real.

El fabricante se reserva el derecho de realizar en todo momento modificaciones a los repuestos. Esto resulta aplicable tanto para las cantidades indicadas de los repuestos como para su diseño técnico. Para obtener la información más reciente sobre la máquina, le rogamos contactarse con un concesionario.

Los datos técnicos, las medidas y los pesos no son vinculantes y se corresponden con la situación al momento de la impresión. Se reserva el derecho a corregir errores.

Las modificaciones técnicas no permitidas de la máquina afectan negativamente la seguridad operativa.

La seguridad operativa se garantiza únicamente a través de la utilización de repuestos originales y de dispositivos adosados/accesorios autorizados.

El fabricante no se responsabilizará por daños que resulten de una modificación técnica no permitida o de la no utilización de repuestos originales.

Tablas de conversión

Volumen	
1 ml	0.034 fl.oz. EE. UU.
1 l	0.260 gal
Longitudes	
1 mm	0.039 in
1 m	3.280 ft
Peso	
1 kg	2.200 lbs
1 g	0.035 oz
Velocidad	
1 km/h	0.620 mph
Par de giro	
1 Nm	0.740 ft.lbs



Información general sobre el libro de repuestos

Estructura

1. Descripción del módulo/de la página del catálogo de repuestos
2. Información adicional (Information) sobre el respectivo módulo/la página del catálogo de repuestos o el número de material. Esta puede incluir lo siguiente:
 - < WXXXXXXXXX1234567 o A: WXXXXXXXXX1234567: válido hasta el número de serie
 - > WXXXXXXXXX1234568 o E: WXXXXXXXXX1234568: válido a partir del número de serie
 - Opción: este material solo se necesita para una opción determinada
 - etc.
3. Superficie de dibujo: Aquí se muestran todos los repuestos que se encuentran en el módulo.
4. La presencia de varios repuestos dentro de un marco/entre paréntesis indica que se trata de un juego/kit. En caso de realizar un pedido del número de ítem correspondiente, se entregarán todos los repuestos que se encuentran allí.
5. Número del módulo. ¡Precaución! ¡Este número no puede pedirse!
6. Denominación de venta de la máquina o número de material de venta - versión
7. Indicación de página
8. Número de ítem (Ref.)
9. Número de material (Part No.)
10. Descripción del material
11. Cantidad montada (Qty.)
12. Unidad de cantidad (Unit)
13. Opcional: aquí se muestra la respectiva opción mediante un pictograma.

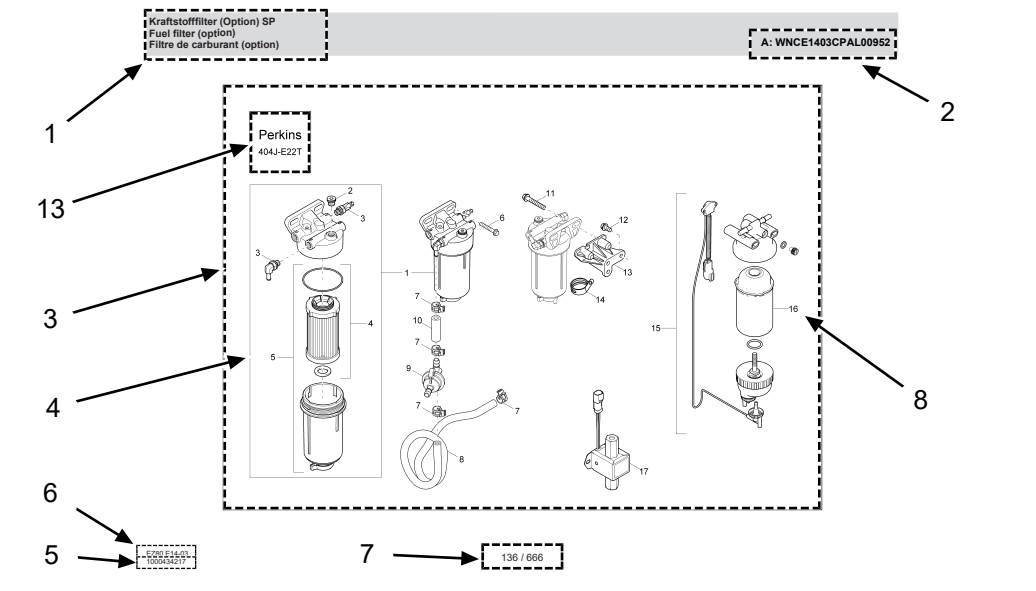

Kraftstofffilter (Option) SP						A: WNCE1403CPAL00952	
Fuel filter (option)							
Filtre de carburant (option)							
Ref.	Part No.	Beschreibung	Description	Description	Information	Qty.	Unit
1	1000386655	Kraftstofffilter	Fuel filter	Filtre de carburant		1	pc
2	1000389249	Stopfen	Plug	Bouchon		1	pc
3	1000389229	Verschraubung	Screw joint	Raccord		2	pc
4	1000386656	Filtereinsatz	Filter insert	Cartouche filtrante		1	pc
5	1000433955	Filtergehäuse	Filter housing	Bolle de filtre		1	pc
6	1000139973	Schraube	Screw	Vis		1	pc
7	1000389241	Schlauchschelle	Hose clamp	Bride de fixation flexible		4	pc
8	1000389247	Kraftstoffschlauch	Fuel line	Tuyau flexible de combustible		1	pc
9	1000434006	Druckbegrenzungsventil	Pressure limit reliefvalve	Soupape limitrice de pression		1	pc
10	1000389230	Kraftstoffschlauch	Fuel line	Tuyau flexible de combustible		1	pc
11	1000139973	Schraube	Screw	Vis		1	pc
12	1000083888	Schraube	Screw	Vis		3	pc
13	1000433952	Arm	Arm	Bras		1	pc
14	1000328508	Klammer	Clamp	Attache		1	pc
15	1000433949	Kraftstofffilter	Fuel filter	Filtre de carburant		1	pc
16	1000433950	Kraftstofffilter	Fuel filter	Filtre de carburant		1	pc
17	1000389262	Kraftstoffpumpe	Fuel pump	Pompe de remplissage	A: WNCE1403CPAL00952	1	pc



1000434217

137 / 666

General information on the spare parts catalog

General information

When ordering spare parts, make sure that all information on the machine is complete.

This includes the sales designation of the machine, the serial number and the year of manufacture. When placing orders for engine or axle parts, the type and serial number of the components are also required.

The following additional information is also required: Material number and item number.

The serial number is stamped into the machine frame. It can also be found on the type label. The serial number must be stated in full.

The machine on the cover picture may have special equipment (options/accessories). The illustration is not binding for the version.

The number of spare parts stated in the spare parts catalog refers to the assembly shown in this drawing.

This spare parts catalog contains all options that are available for the machine from the factory. For this reason, options may also be shown with which the machine is not equipped. Not all options shown are available in all countries/regions.

Options/accessories are partially retrofittable. Not all options can be combined with each other.

In some cases, the catalog also shows components that are not available as spare parts. These components are not depicted as items on the drawings. The illustration serves only the purpose of understanding and makes no claim to the illustrated component.

The "left" and "right" indications in the description or information always refer to the machine in the direction of forward travel..

We are constantly working to improve and optimize our products in the course of technical development. For this reason, it may be possible that illustrations in the spare parts catalog differ from the actual design.

The manufacturer reserves the right to make changes to the spare parts at any time. This applies both to the stated quantity of spare parts and to the technical design. To obtain the latest information on the machine, please contact an authorized dealer.

Technical specifications, dimensions and weights are not binding and correspond to the state at the time of printing. Responsibility for errors or omissions not accepted.

Unauthorized technical modifications to the machine lead to a significant impairment of operational safety.

Operational safety is only ensured by using original spare parts and approved attachments/accessories.

The manufacturer shall assume no liability for damage caused by unauthorized technical modifications or the non-use of original spare parts.

Conversion table

Volumes	
1 ml	0.034 US fl.oz.
1 l	0.260 gal
Lengths	
1 mm	0.039 in
1 m	3.280 ft
Mass	
1 kg	2.200 lbs
1 g	0.035 oz
Speed	
1 km/h	0.620 mph
Torque	
1 Nm	0.740 ft.lbs

General information on the spare parts catalog

Structure

1. Description of the module/spare parts catalog page
2. Further information (Information) on the respective assembly/spare parts catalog page or the material number. This may include the following:
 - < WXXXXXXXXX1234567 or A: WXXXXXXXXX1234567: valid until serial number
 - > WXXXXXXXXX1234568 or E: WXXXXXXXXX1234568: valid from serial number
 - Option: this material is only needed for a specific option
 - etc.
3. Drawing area: All spare parts that are available in the assembly are displayed here.
4. Several spare parts within a frame/or bracket indicate a set/kit. If the corresponding item number is ordered, all spare parts that this item number encompasses are delivered.
5. Number of the assembly. Attention! This number cannot be ordered!
6. Sales designation of the machine or sales material number - Version
7. Page reference
8. Item number (Ref.)
9. Material number (Part No.)
10. Material description
11. Installed quantity (Qty.)
12. Quantity unit (Unit)
13. Optional: The respective option is represented by a pictogram here.

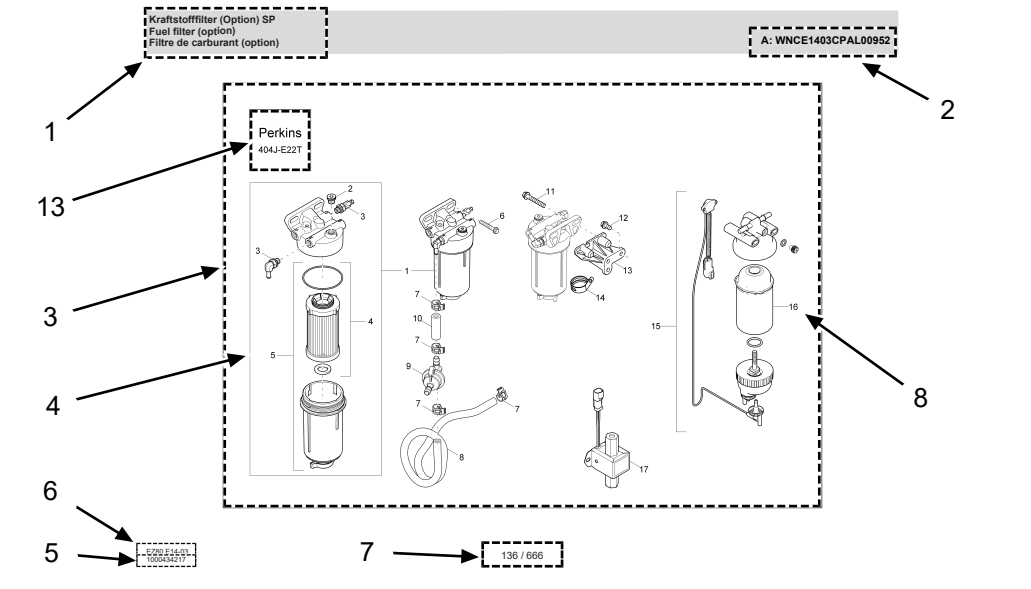

Kraftstofffilter (Option) SP						A: WNCE1403CPAL00952	
Fuel filter (option)							
Filtre de carburant (option)							
Ref.	Part No.	Beschreibung	Description	Description	Information	Qty.	Unit
1	1000389229	Kraftstofffilter	Fuel filter	Filtre de carburant		1	pc
2	1000389249	Stopfen	Plug	Bouchon		1	pc
3	1000389229	Verschraubung	Screw joint	Raccord		2	pc
4	1000389229	Filtreinsatz	Filter insert	Cartouche filtrante		1	pc
5	1000433955	Filtergehäuse	Filter housing	Bolle de filtre		1	pc
6	1000139973	Schraube	Screw	Vis		1	pc
7	1000389241	Schlauchschelle	Hose clamp	Bride de fixation flexible		4	pc
8	1000389247	Kraftstoffschlauch	Fuel line	Tuyau flexible de combustible		1	pc
9	1000434006	Druckbegrenzungsventil	Pressure limit reliefvalve	Souape limite de pression		1	pc
10	1000389230	Kraftstoffschlauch	Fuel line	Tuyau flexible de combustible		1	pc
11	1000139973	Schraube	Screw	Vis		1	pc
12	1000088388	Schraube	Screw	Vis		3	pc
13	1000433952	Arm	Arm	Bras		1	pc
14	1000328508	Klammer	Clamp	Attache		1	pc
15	1000433949	Kraftstofffilter	Fuel filter	Filtre de carburant		1	pc
16	1000433950	Kraftstofffilter	Fuel filter	Filtre de carburant		1	pc
17	1000389282	Kraftstoffpumpe	Fuel pump	Pompe de remplissage	A: WNCE1403CPAL00952	1	pc



Indice
Índice
Contents

1	Telaio con componenti Bastidor con piezas de montaje Main frame and assemblies	14
2	Telaio con componenti Bastidor con piezas de montaje Main frame and assemblies	18
3	Componenti rivestimento e coperchio Piezas de revestimiento y tapas Canopies and covers	22
4	Componenti rivestimento e coperchio Piezas de revestimiento y tapas Canopies and covers	24
5	Componenti rivestimento e coperchio Piezas de revestimiento y tapas Canopies and covers	26
6	Postazione del conducente Puesto del conductor Operator's platform	30
7	Montaggio motore e pompa Montaje de motor y bomba Pump drive and engine assembly	32
8	Montaggio motore e pompa Montaje de motor y bomba Pump drive and engine assembly	36
9	Montaggio motore e pompa Montaje de motor y bomba Pump drive and engine assembly	38
10	Impianto di alimentazione del carburante Sistema de combustible Fuel system	40
11	Filtro carburante Filtro de combustible Fuel filter	42



Indice
Índice
Contents

12	Impianto filtro dell'aria Sistema filtro de aire Air filter system	44
13	Impianto di scarico Sistema de escape Exhaust system	46
14	Post-trattamento del gas di scarico Tratamiento posterior de gases de escape Exhaust aftertreatment	48
15	Post-trattamento del gas di scarico Tratamiento posterior de gases de escape Exhaust aftertreatment	50
16	Raffreddamento (motore/olio idraulico) Refrigeración (motor/aceite hidráulico) Cooling (engine/hydraulic oil)	52
17	Raffreddamento (motore/olio idraulico) Refrigeración (motor/aceite hidráulico) Cooling (engine/hydraulic oil)	54
18	Raffreddamento (motore/olio idraulico) Refrigeración (motor/aceite hidráulico) Cooling (engine/hydraulic oil)	56
19	Raffreddamento (motore/olio idraulico) Refrigeración (motor/aceite hidráulico) Cooling (engine/hydraulic oil)	58
20	Pompa di regolazione (trazione) Bomba regulable (acc. trasl.) Variable displac. pump (drive)	60
21	Pompa di regolazione (vibratore) Bomba regulable (vibración) Variable displac. pump (vibr.)	64
22	Constant motor (vibration driv Motor constante (accionamiento Constant motor (vibration driv	66

Indice
Índice
Contents

23	Unità di distribuzione Unidad del distribuidor Distributor unit	68
24	Motore sui mozzi delle ruote Motor del cubo de la rueda Gear hub motor	70
25	Motore sui mozzi delle ruote Motor del cubo de la rueda Gear hub motor	72
26	Motore sui mozzi delle ruote Motor del cubo de la rueda Gear hub motor	74
27	Blocco valvole (freno di stazionamento) Bloque de válvula (freno estac Valve block (parking brake)	76
28	Motore a ingranaggi Motor del engranaje Gear motor	78
29	Pompa tandem Bomba tándem Tandem pump	80
30	Serbatoio olio idraulico Tanque de aceite hidráulico Hydraulic oil tank	82
31	Serbatoio olio idraulico Tanque de aceite hidráulico Hydraulic oil tank	84
32	Serbatoio olio idraulico Tanque de aceite hidráulico Hydraulic oil tank	86
33	Tavola apparecchiature Panel de instrumentos Instrument panel	88



Indice
Índice
Contents

34	Impianto elettrico Sistema electrico Electrical system	90
35	Impianto elettrico Sistema electrico Electrical system	94
36	Impianto elettrico Sistema electrico Electrical system	98
37	Impianto elettrico Sistema electrico Electrical system	100
38	Impianto elettrico Sistema electrico Electrical system	102
39	Impianto elettrico Sistema electrico Electrical system	104
40	Equipaggiamento penumatici Neumáticos Tyre equipment	106
41	Equipaggiamento penumatici Neumáticos Tyre equipment	108
42	Trazione Accionamiento de avance Advance drive	110
43	Trazione Accionamiento de avance Advance drive	112
44	Trazione Accionamiento de avance Advance drive	114



Indice
Índice
Contents

45	Trazione Accionamiento de avance Advance drive	118
46	Trazione Accionamiento de avance Advance drive	120
47	Idraulica freni Freno hidráulico Brake hydraulics	122
48	Cambio velocità Cambio de marchas Gear shifting	124
49	Braccio oscillante-snodabile Articulación central Centre pivot assembly	126
50	Sistema sterzante Dirección Steering	128
51	Fascia Bandaje Roller drum	132
52	Kit di manutenzione e riparazione Kits de mantenimiento y de reparación Maintenance kits and repair kits	136



Telaio con componenti
 Bastidor con piezas de montaje
 Main frame and assemblies

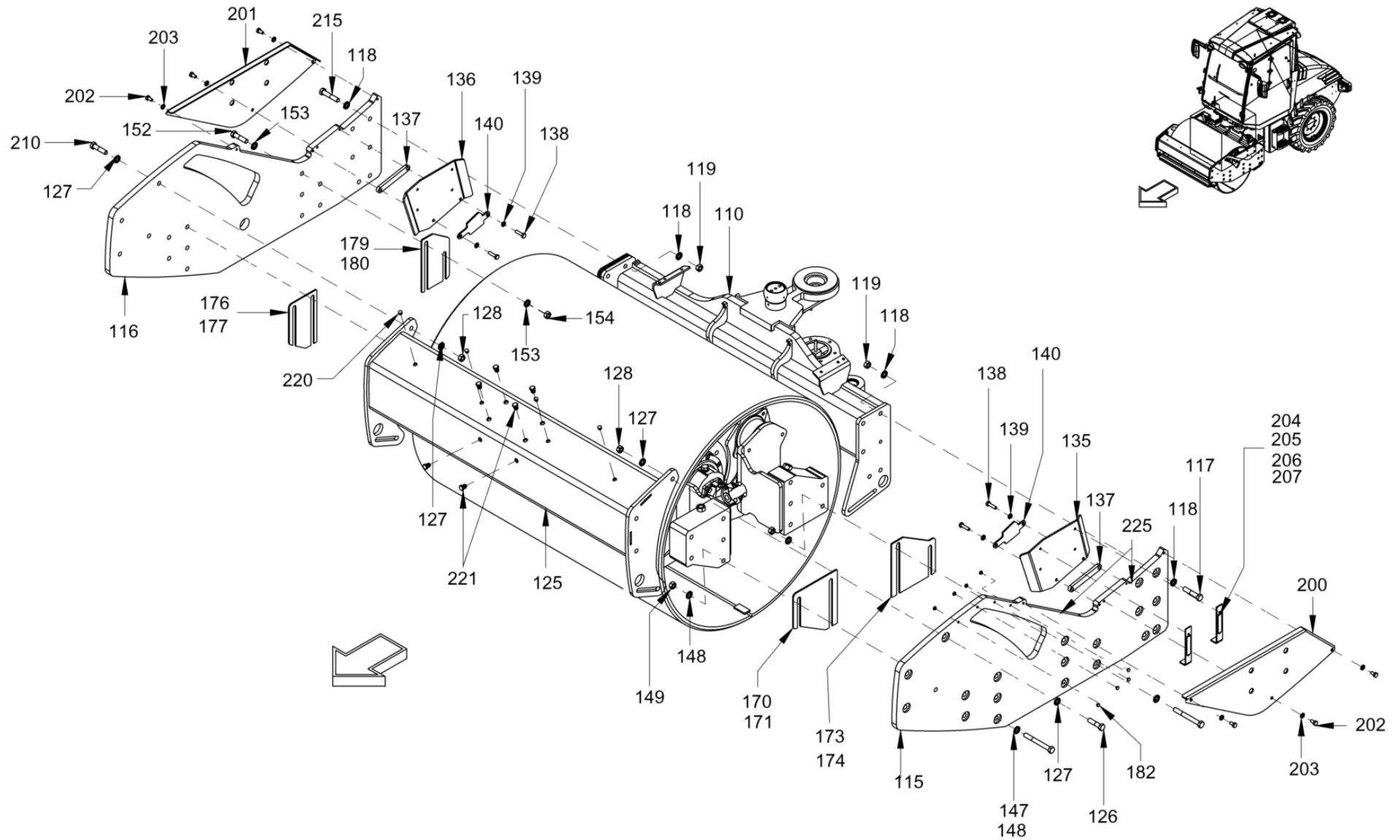

Telaio con componenti
Bastidor con piezas de montaje
Main frame and assemblies

Item	Item no.	Descrizione	Descripción	Description	Information	Pc.	Unit
110	5100070726	Traversa	Traviesa	Traverse		1	pc
115	5100070780	Componente laterale	Pieza lateral	Side part		1	pc
116	5100070792	Componente laterale	Pieza lateral	Side part		1	pc
117	5100070805	Vite esagonale	Tornillo hexagonal	Hexagon screw		6	pc
118	5100012969	Rondella di sicurezza	Disco de seguridad	Locking washer		24	pc
119	5100012405	Dado esagonale	Tuerca hexagonal	Hexagon nut		12	pc
125	5100070817	Traversa	Traviesa	Traverse		1	pc
126	5100070805	Vite esagonale	Tornillo hexagonal	Hexagon screw		4	pc
127	5100012969	Rondella di sicurezza	Disco de seguridad	Locking washer		12	pc
128	5100012405	Dado esagonale	Tuerca hexagonal	Hexagon nut		4	pc
135	5100023288	Lamiera	Chapa	Metal plate		1	pc
136	5100023289	Lamiera	Chapa	Metal plate		1	pc
137	5100023350	Distanziatore	Pieza distanciadora	Distance piece		2	pc
138	5100012523	Bullone esagonale	Tornillo hexagonal	Hexagon screw		4	pc
139	5100012967	Rondella di sicurezza	Disco de seguridad	Locking washer		4	pc
140	5100023541	Lamiera	Chapa	Metal plate		2	pc
147	5100013232	Bullone esagonale	Tornillo hexagonal	Hexagon screw		10	pc
148	5100012969	Rondella di sicurezza	Disco de seguridad	Locking washer		20	pc
149	5100012405	Dado esagonale	Tuerca hexagonal	Hexagon nut		10	pc
152	5100070805	Vite esagonale	Tornillo hexagonal	Hexagon screw		10	pc
153	5100012969	Rondella di sicurezza	Disco de seguridad	Locking washer		20	pc
154	5100012405	Dado esagonale	Tuerca hexagonal	Hexagon nut		10	pc
170	5100023561	Piastra distanziale	Chapa de distancia	Distance sheet		2	pc
171	5100023562	Piastra distanziale	Chapa de distancia	Distance sheet		3	pc
173	5100023563	Piastra distanziale	Chapa de distancia	Distance sheet		2	pc
174	5100023564	Piastra distanziale	Chapa de distancia	Distance sheet		3	pc
176	5100070692	Lamiera distanziatrice	Chapa de distancia	Distance sheet		2	pc
177	5100070685	Lamiera distanziatrice	Chapa de distancia	Distance sheet		3	pc
179	5100070697	Lamiera distanziatrice	Chapa de distancia	Distance sheet		2	pc
180	5100070709	Lamiera distanziatrice	Chapa de distancia	Distance sheet		3	pc
182	5100040276	Tappo a vite	Tapón de cierre	Filler cap		8	pc
200	5100025983	Lamiera	Chapa	Metal plate		1	pc
201	5100025984	Lamiera	Chapa	Metal plate		1	pc
202	5100012520	Bullone esagonale	Tornillo hexagonal	Hexagon screw		6	pc
203	5100012967	Rondella di sicurezza	Disco de seguridad	Locking washer		6	pc
204	5100011866	Nastro sigillante	Cinta impermeabilizante	Sealing tape		0.07	m

Telaio con componenti
 Bastidor con piezas de montaje
 Main frame and assemblies

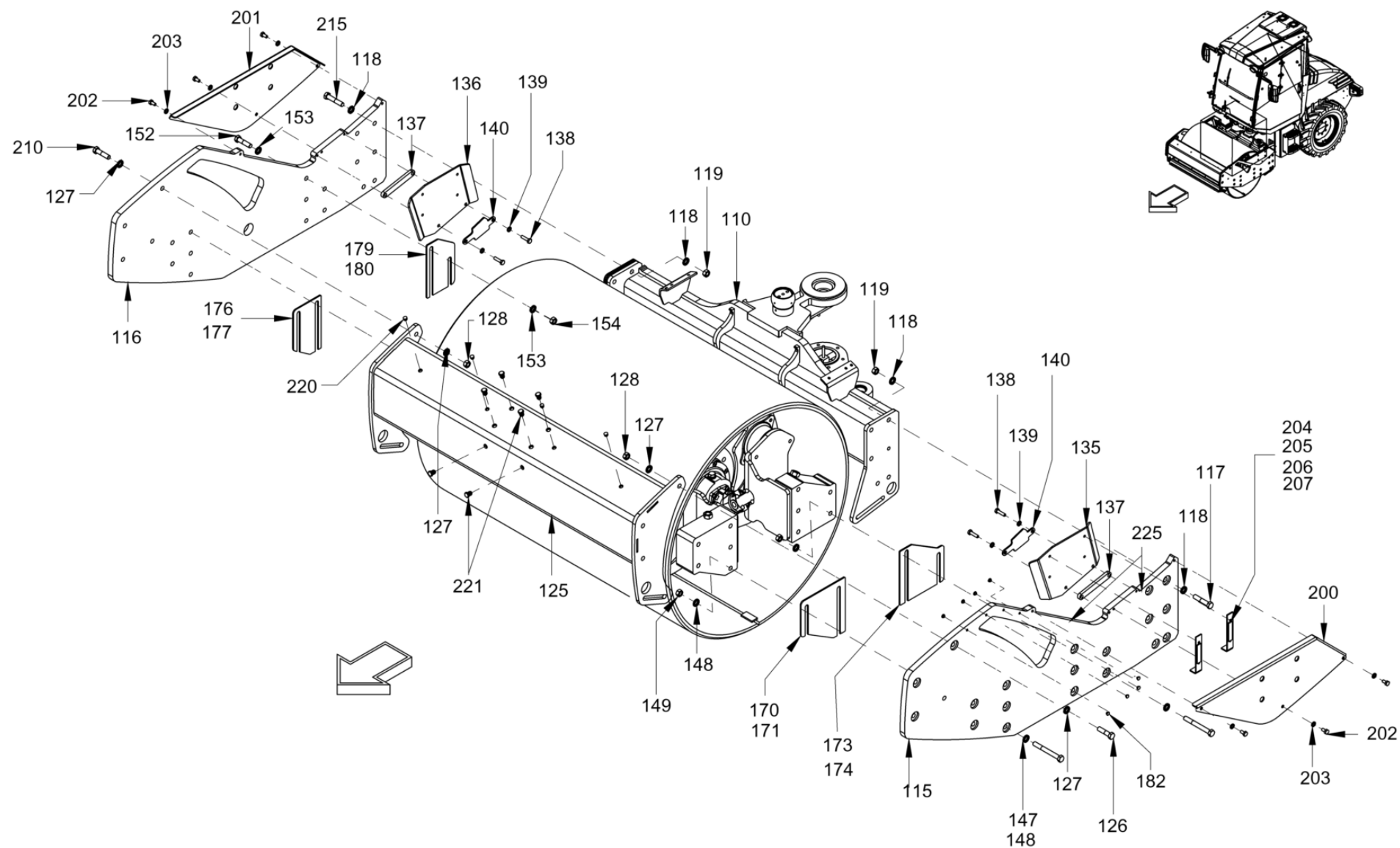

Telaio con componenti
Bastidor con piezas de montaje
Main frame and assemblies

Item	Item no.	Descrizione	Descripción	Description	Information	Pc.	Unit
205	5100011866	Nastro sigillante	Cinta impermeabilizante	Sealing tape		0.07	m
206	5100011866	Nastro sigillante	Cinta impermeabilizante	Sealing tape		0.07	m
207	5100011866	Nastro sigillante	Cinta impermeabilizante	Sealing tape		0.07	m
210	5100023177	Bullone esagonale	Tornillo hexagonal	Hexagon screw		3	pc
215	5100023177	Bullone esagonale	Tornillo hexagonal	Hexagon screw		6	pc
220	5100012493	Tappo a vite	Tapón de cierre	Filler cap		4	pc
221	5100018010	Tappo a vite	Tapón de cierre	Filler cap		6	pc
225	5100046875	Nastro sigillante	Cinta impermeabilizante	Sealing tape		1.8	m



Telaio con componenti
 Bastidor con piezas de montaje
 Main frame and assemblies

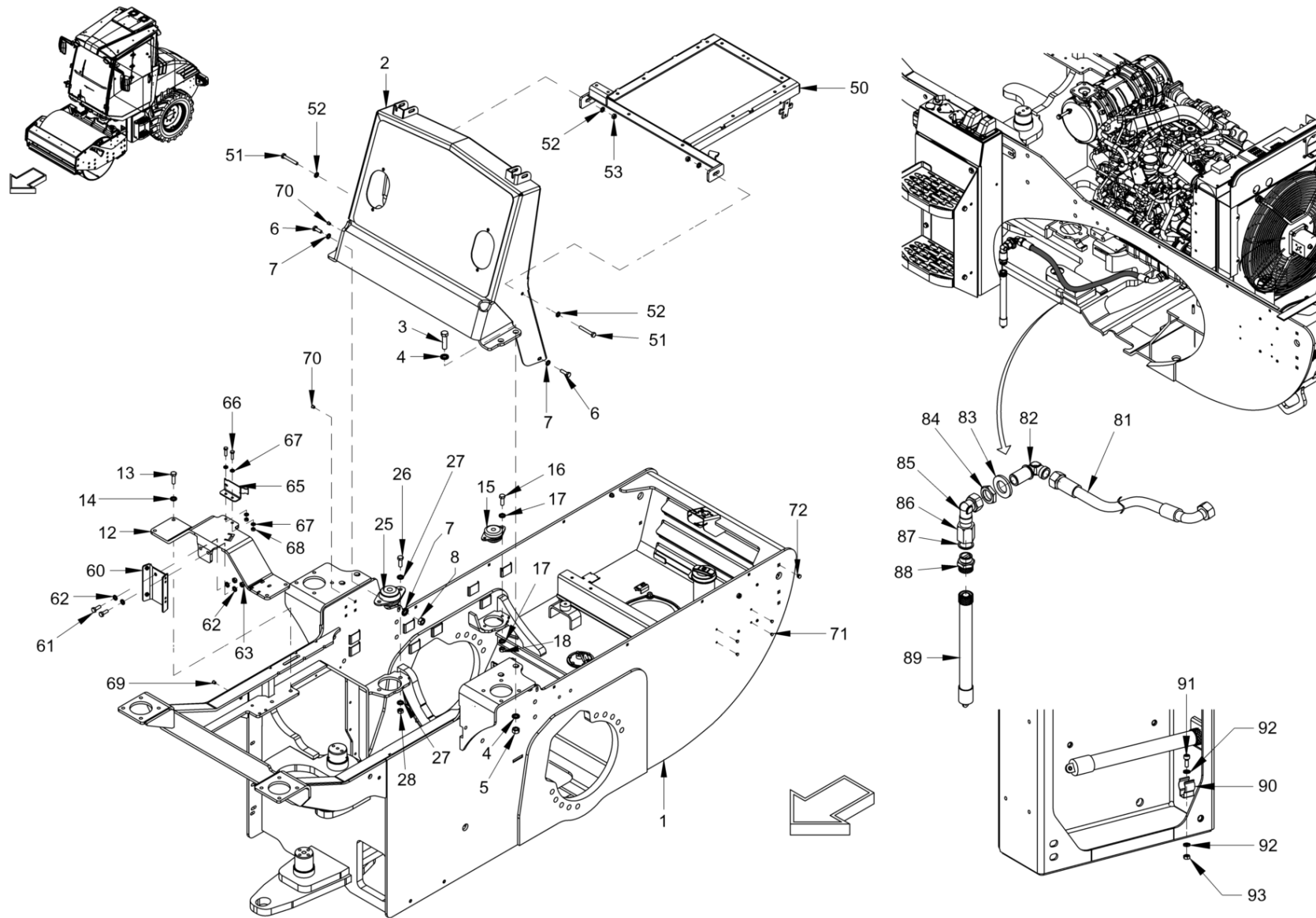

Telaio con componenti
Bastidor con piezas de montaje
Main frame and assemblies

Item	Item no.	Descrizione	Descripción	Description	Information	Pc.	Unit
1	5100070738	Telaio	Bastidor	Frame		1	pc
2	5100070731	Cofano	Tapa de motor	Engine cover		1	pc
3	5100022910	Bullone esagonale	Tornillo hexagonal	Hexagon screw		4	pc
4	5100034679	Rondella	Arandela	Washer		8	pc
5	5100022923	Dado esagonale	Tuerca hexagonal	Hexagonal nut		4	pc
6	5100012523	Bullone esagonale	Tornillo hexagonal	Hexagon screw		2	pc
7	5100012967	Rondella di sicurezza	Disco de seguridad	Locking washer		4	pc
8	5100012547	Dado esagonale	Tuerca hexagonal	Hexagon nut		2	pc
12	5100070743	Supporto	Soporte	Holder		1	pc
13	5100012617	Bullone esagonale	Tornillo hexagonal	Hexagon screw		4	pc
14	5100012967	Rondella di sicurezza	Disco de seguridad	Locking washer		4	pc
15	5100070755	Supporto motore	Soporte del motor	Engine mount		2	pc
16	5100013510	Bullone esagonale	Tornillo hexagonal	Hexagon screw		4	pc
17	5100012966	Rondella di sicurezza	Disco de seguridad	Locking washer		8	pc
18	5100012546	Dado esagonale	Tuerca hexagonal	Hexagon nut		4	pc
25	5100070767	Supporto motore	Soporte del motor	Engine mount		2	pc
26	5100012621	Bullone esagonale	Tornillo hexagonal	Hexagon screw		4	pc
27	5100012968	Rondella di sicurezza	Disco de seguridad	Locking washer		8	pc
28	5100012548	Dado esagonale	Tuerca hexagonal	Hexagon nut		4	pc
50	5100023369	Supporto	Fijación	Holder system		1	pc
51	5100064091	Vite esagonale	Tornillo hexagonal	Hexagon screw		2	pc
52	5100012967	Rondella di sicurezza	Disco de seguridad	Locking washer		4	pc
53	5100012547	Dado esagonale	Tuerca hexagonal	Hexagon nut		2	pc
60	5100023525	Supporto	Soporte	Holder		1	pc
61	5100012617	Bullone esagonale	Tornillo hexagonal	Hexagon screw		2	pc
62	5100012967	Rondella di sicurezza	Disco de seguridad	Locking washer		4	pc
63	5100012547	Dado esagonale	Tuerca hexagonal	Hexagon nut		2	pc
65	5100070775	Supporto	Soporte	Holder		1	pc
66	5100013510	Bullone esagonale	Tornillo hexagonal	Hexagon screw		2	pc
67	5100012966	Rondella di sicurezza	Disco de seguridad	Locking washer		4	pc
68	5100012546	Dado esagonale	Tuerca hexagonal	Hexagon nut		2	pc
69	5100040276	Tappo a vite	Tapón de cierre	Filler cap		1	pc
70	5100040279	Tappo a vite	Tapón de cierre	Filler cap		5	pc
71	5100013530	Tappo a vite	Tapón de cierre	Filler cap		4	pc
72	5100012493	Tappo a vite	Tapón de cierre	Filler cap		3	pc
81	5100040580	Tubo flessibile	Manguera	Hose		1	pc



Telaio con componenti
 Bastidor con piezas de montaje
 Main frame and assemblies

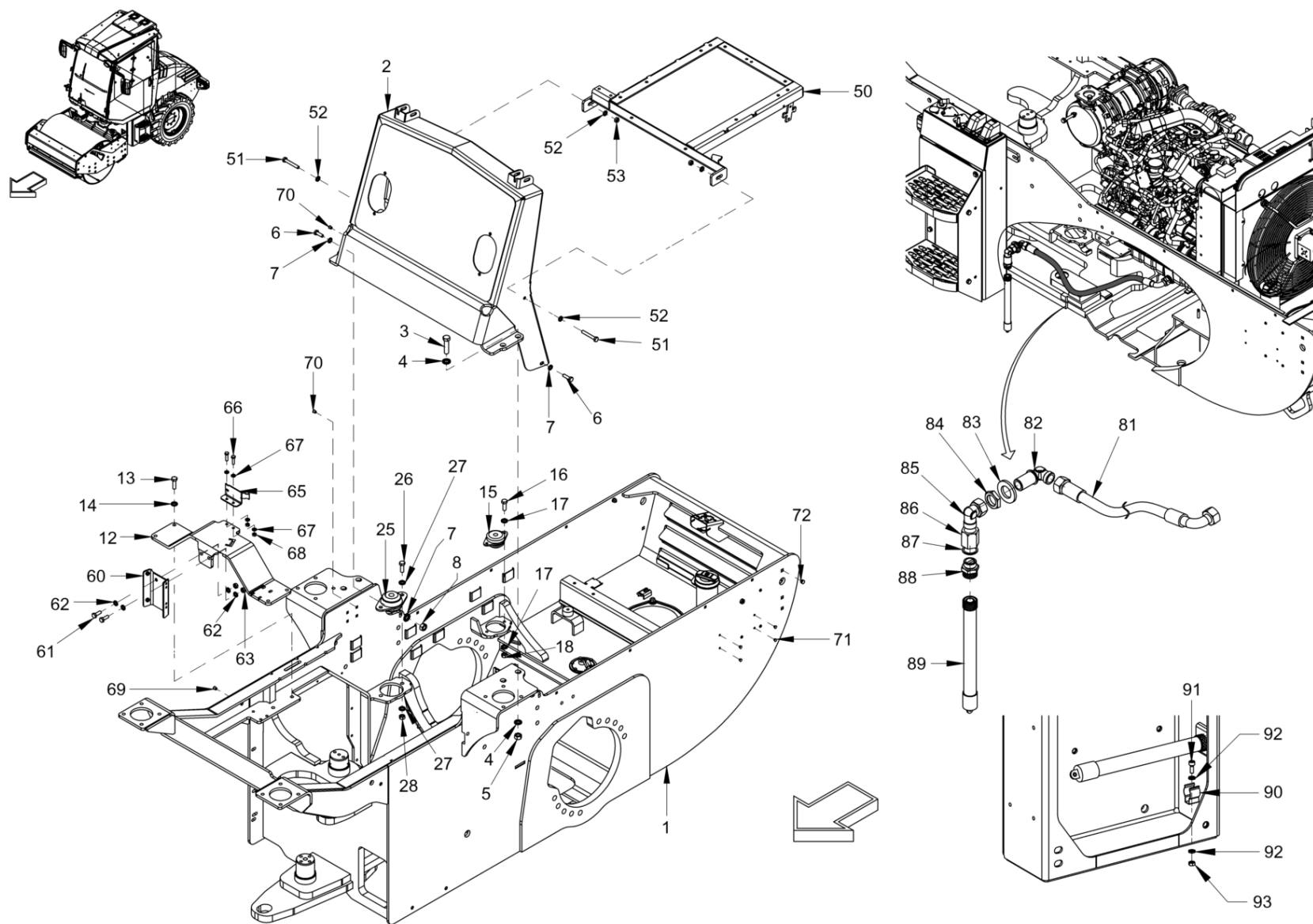

Telaio con componenti
Bastidor con piezas de montaje
Main frame and assemblies

Item	Item no.	Descrizione	Descripción	Description	Information	Pc.	Unit
82	5100034680	Connettore a paratia angolare	Codo mampara	Bulkhead elbow		1	pc
83	5100040581	Finestrino	Arandela	Washer		1	pc
84	5100034681	Dado esagonale	Tuerca hexagonal	Hexagonal nut		1	pc
85	5100022890	Connettore a gomito regolabile	Racor angular ajustable	Elbow adjustable		1	pc
86	5100048696	Giunto	Manguito de acoplamiento	Fitting		1	pc
87	5100022863	Guarnizione	Anillo de junta	Sealing ring		1	pc
88	5100040583	Valvola di scarico	Válvula de descarga	Discharge valve		1	pc
89	5100040584	Collegamento	Pieza de conexion	Connecting piece		1	pc
90	5100070776	Clip	Clip	Clip		1	pc
91	5100011443	Vite a testa cilindrica	Tornillo cilíndrico	Cheese-head screw		1	pc
92	5100012965	Rondella di sicurezza	Disco de seguridad	Locking washer		2	pc
93	5100012545	Dado esagonale	Tuerca hexagonal	Hexagon nut		1	pc



Componenti rivestimento e coperchio
Piezas de revestimiento y tapas
Canopies and covers

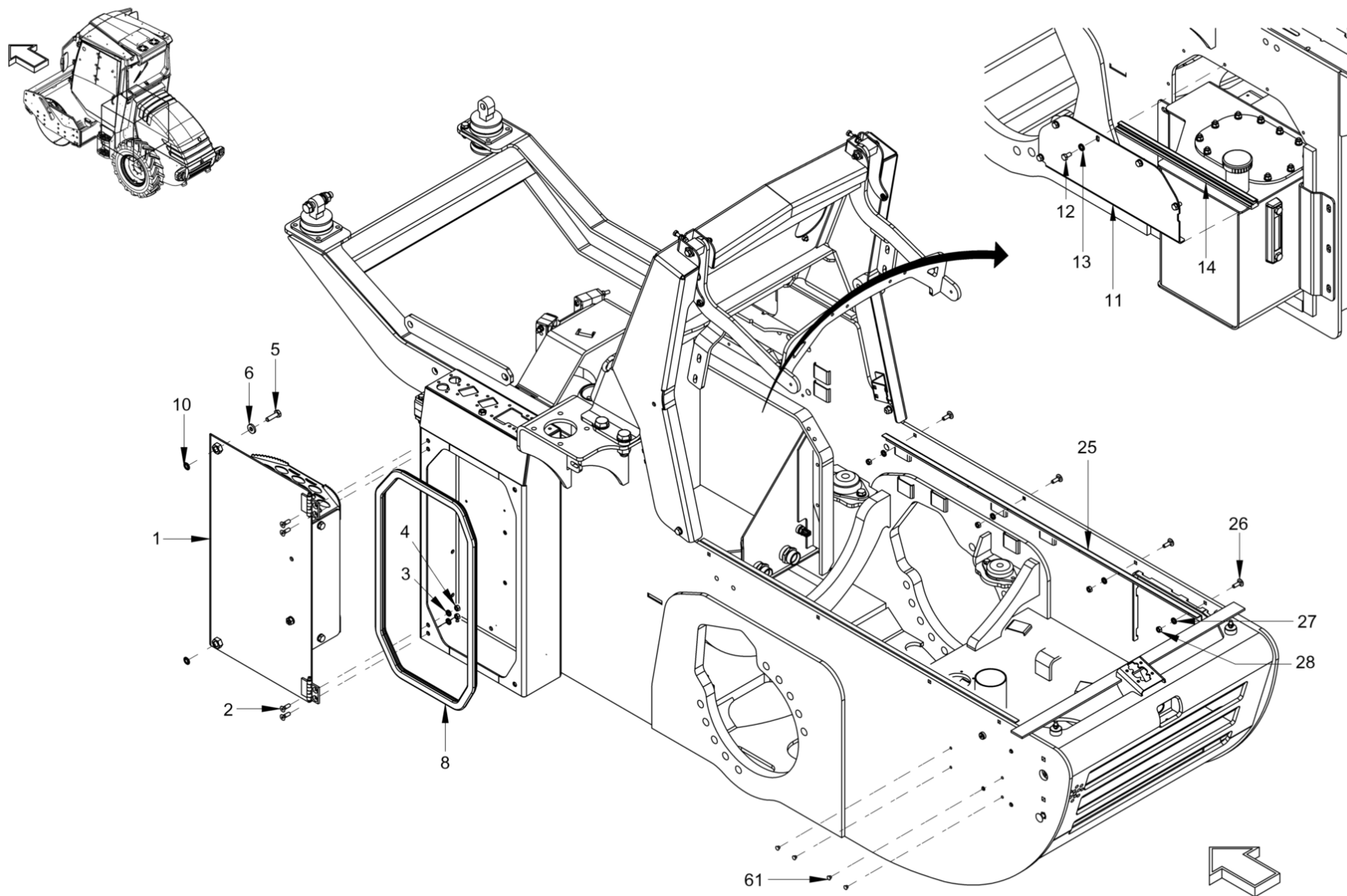

Componenti rivestimento e coperchio
Piezas de revestimiento y tapas
Canopies and covers

Item	Item no.	Descrizione	Descripción	Description	Information	Pc.	Unit
1	5100070777	Coperchio	Tapa	Lid		1	pc
2	5100034693	Vite svasata	Tornillo avellanado	Countersunk screw		4	pc
3	5100013094	Rondella	Arandela	Washer		4	pc
4	5100053004	Controdado	Tuerca de seguridad	Safety nut		4	pc
5	5100013416	Bullone esagonale	Tornillo hexagonal	Hexagon screw		2	pc
6	5100013521	Rondella	Arandela	Washer		2	pc
8	5100013443	Profilo di tenuta	Perfil de impermeabilización	Sealing profile		2	m
10	5100023625	Rondella di sicurezza	Disco de seguridad	Locking washer		2	pc
11	5100070778	Coperchio	Tapa	Lid		1	pc
12	5100012515	Bullone esagonale	Tornillo hexagonal	Hexagon screw		5	pc
13	5100012966	Rondella di sicurezza	Disco de seguridad	Locking washer		5	pc
14	5100013443	Profilo di tenuta	Perfil de impermeabilización	Sealing profile		0.423	m
25	5100023399	Lamiera	Chapa	Metal plate		2	pc
26	5100012780	Vite a testa tonda	Tornillo cil. cabeza rebajada	Mushroom head screw		8	pc
27	5100012966	Rondella di sicurezza	Disco de seguridad	Locking washer		8	pc
28	5100012546	Dado esagonale	Tuerca hexagonal	Hexagon nut		8	pc
61	5100013530	Tappo a vite	Tapón de cierre	Filler cap		4	pc

Componenti rivestimento e coperchio
Piezas de revestimiento y tapas
Canopies and covers

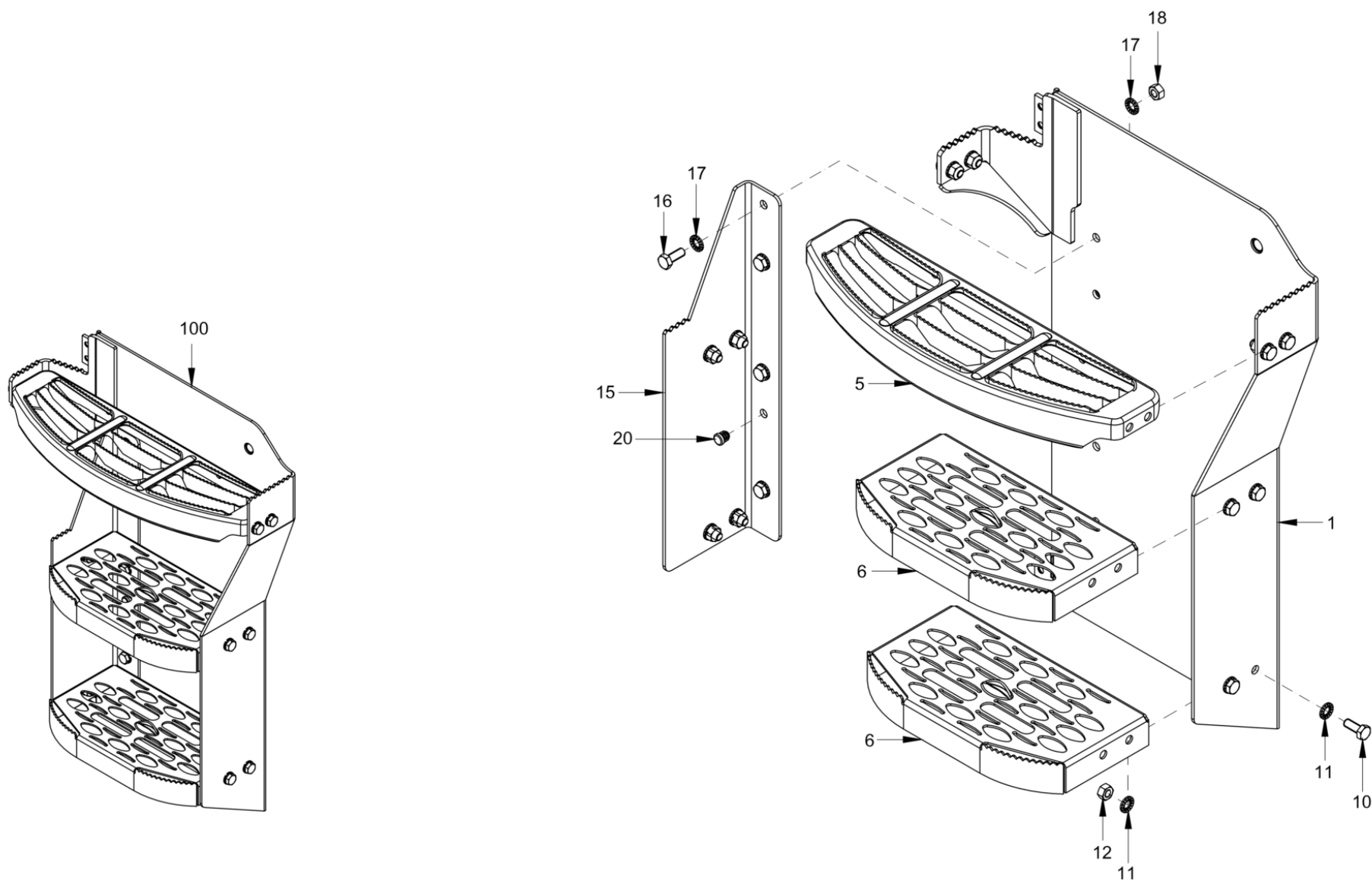

Componenti rivestimento e coperchio
Piezas de revestimiento y tapas
Canopies and covers

Item	Item no.	Descrizione	Descripción	Description	Information	Pc.	Unit
1	5100070779	Coperchio	Tapa	Lid		1	pc
5	5100034707	Ingresso	Apoyapies	Footstep		1	pc
6	5100023239	Ingresso	Apoyapies	Footstep		2	pc
10	5100011479	Bullone esagonale	Tornillo hexagonal	Hexagon screw		12	pc
11	5100012967	Rondella di sicurezza	Disco de seguridad	Locking washer		24	pc
12	5100012547	Dado esagonale	Tuerca hexagonal	Hexagon nut		12	pc
15	5100070781	Supporto	Soporte	Holder		1	pc
16	5100011479	Bullone esagonale	Tornillo hexagonal	Hexagon screw		4	pc
17	5100012967	Rondella di sicurezza	Disco de seguridad	Locking washer		8	pc
18	5100012547	Dado esagonale	Tuerca hexagonal	Hexagon nut		4	pc
20	5100040279	Tappo a vite	Tapón de cierre	Filler cap		3	pc
100	5100070777	Coperchio	Tapa	Lid		1	pc

Componenti rivestimento e coperchio
 Piezas de revestimiento y tapas
 Canopies and covers

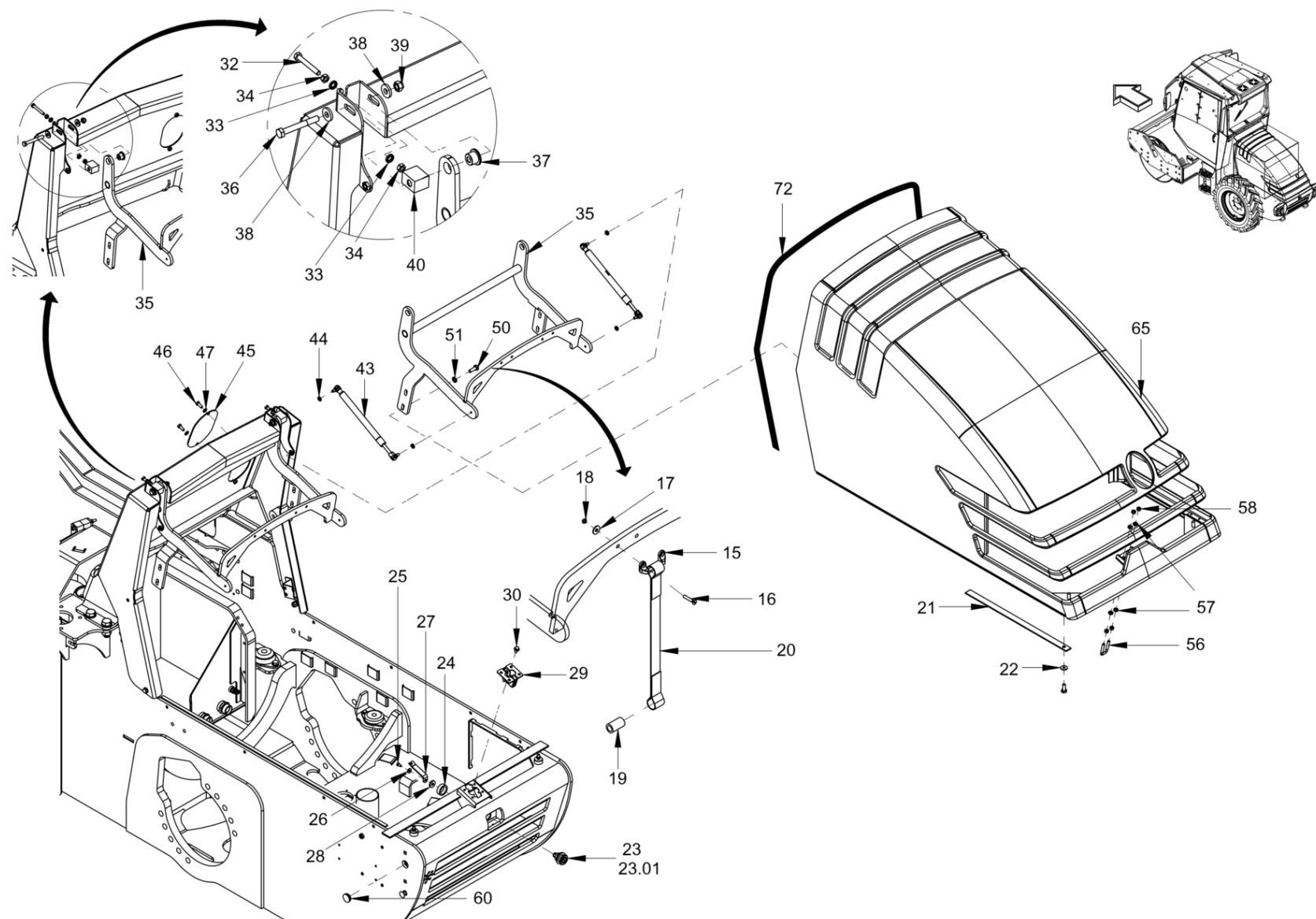

Componenti rivestimento e coperchio
Piezas de revestimiento y tapas
Canopies and covers

Item	Item no.	Descrizione	Descripción	Description	Information	Pc.	Unit
15	5100013309	Supporto	Soporte	Bracket		1	pc
16	5100025827	Vite svasata	Tornillo avellanado	Countersunk screw		2	pc
17	5100013523	Rondella	Arandela	Washer		2	pc
18	5100011599	Dado esagonale	Tuerca hexagonal	Hexagon nut		2	pc
19	5100013223	Tubo flessibile	Manguera	Flexible tubing		0.04	m
20	5100025947	Nastro di cattura	Cinta de retención	Rebound strap		1	pc
21	5100025951	Nastro di cattura	Cinta de retención	Rebound strap		1	pc
22	5100013421	Rondella	Arandela	Washer		1	pc
23	5100013557	Chiave	Llave	Key	23.01	1	pc
23	5100013596	Serratura incorporata	Cerradura incorporada	Built-in lock		1	pc
24	5100011698	Distanziatore	Pieza distanciadora	Spacer block		1	pc
25	5100012600	Bullone esagonale	Tornillo hexagonal	Hexagon screw		1	pc
26	5100012937	Rondella	Arandela	Washer		1	pc
27	5100023343	Lamiera	Chapa	Metal plate		1	pc
28	5100011636	Rondella	Arandela	Washer		1	pc
29	5100012696	Chiusura a scrocco rotante	Cierre giratorio	Lock		1	pc
30	5100012498	Vite di sicurezza	Tornillo de seguridad	Safety screw		4	pc
32	5100012714	Bullone esagonale	Tornillo hexagonal	Hexagon screw		2	pc
33	5100012966	Rondella di sicurezza	Disco de seguridad	Locking washer		4	pc
34	5100012546	Dado esagonale	Tuerca hexagonal	Hexagon nut		4	pc
35	5100070783	Cofano	Tapa de motor	Engine cover		1	pc
36	5100064091	Vite esagonale	Tornillo hexagonal	Hexagon screw		2	pc
37	5100070784	Boccola	Casquillo	Bushing		2	pc
38	5100013521	Rondella	Arandela	Washer		4	pc
39	5100063880	Controdado	Tuerca de seguridad	Safety nut		2	pc
40	5100070785	Blocco	Bloque	Block		2	pc
43	5100023298	Molla a gas	Amortiguador neumático	Gas spring		2	pc
44	5100012966	Rondella di sicurezza	Disco de seguridad	Locking washer		4	pc
45	5100070786	Coperchio	Tapa	Lid		2	pc
46	5100012517	Bullone esagonale	Tornillo hexagonal	Hexagon screw		4	pc
47	5100012966	Rondella di sicurezza	Disco de seguridad	Locking washer		4	pc
50	5100012617	Bullone esagonale	Tornillo hexagonal	Hexagon screw		4	pc
51	5100012967	Rondella di sicurezza	Disco de seguridad	Locking washer		4	pc
56	5100023257	Supporto	Soporte	Holder		1	pc
57	5100012966	Rondella di sicurezza	Disco de seguridad	Locking washer		4	pc
58	5100012546	Dado esagonale	Tuerca hexagonal	Hexagon nut		4	pc

Componenti rivestimento e coperchio
Piezas de revestimiento y tapas
Canopies and covers

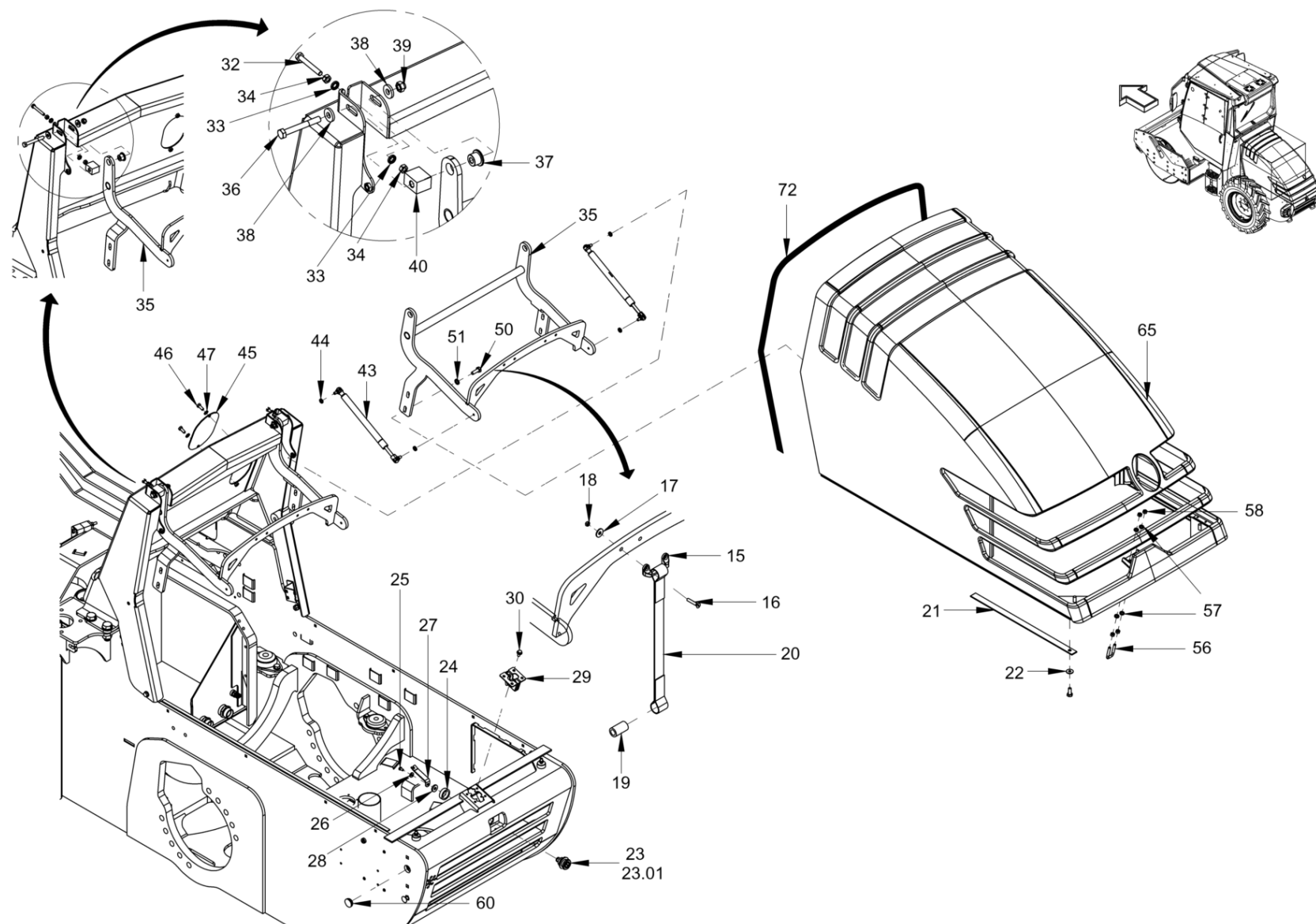

Componenti rivestimento e coperchio
Piezas de revestimiento y tapas
Canopies and covers

Item	Item no.	Descrizione	Descripción	Description	Information	Pc.	Unit
60	5100023166	Tappo a vite	Tapón de cierre	Filler cap		2	pc
65	5100025955	Cofano motore	Tapa de motor	Engine cover		1	pc
72	5100026016	Protezione dei bordi	Protección de cantos	Edge protection		2.4	m



Postazione del conducente
 Puesto del conductor
 Operator's platform

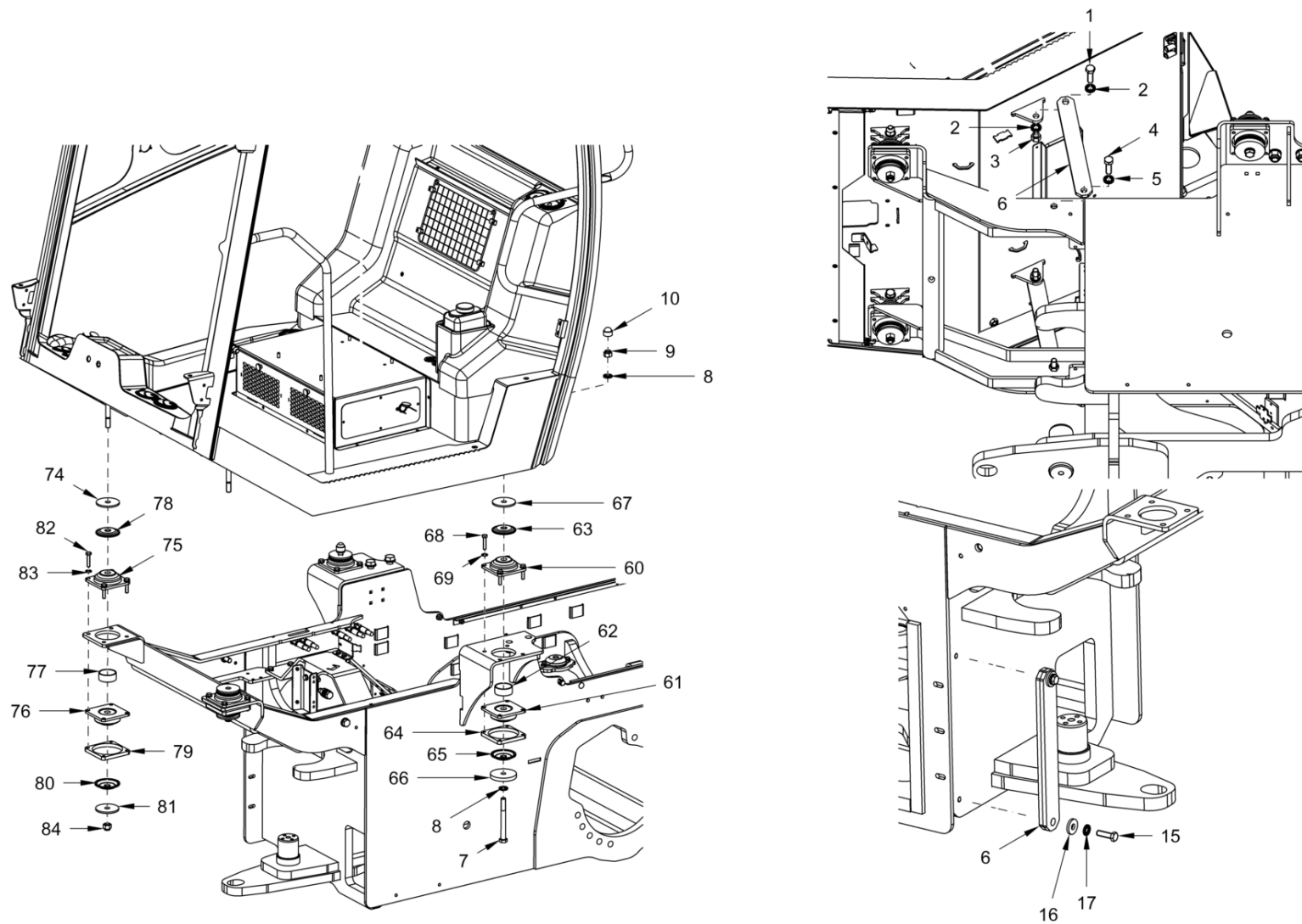

Postazione del conducente
Puesto del conductor
Operator's platform

Item	Item no.	Descrizione	Descripción	Description	Information	Pc.	Unit
1	5100013426	Bullone esagonale	Tornillo hexagonal	Hexagon screw		2	pc
2	5100012969	Rondella di sicurezza	Disco de seguridad	Locking washer		4	pc
3	5100012405	Dado esagonale	Tuerca hexagonal	Hexagon nut		2	pc
4	5100013426	Bullone esagonale	Tornillo hexagonal	Hexagon screw		2	pc
5	5100012969	Rondella di sicurezza	Disco de seguridad	Locking washer		2	pc
6	5100025906	Lamiera	Chapa	Metal plate		2	pc
7	5100022986	Bullone esagonale	Tornillo hexagonal	Hexagon screw		2	pc
8	5100012969	Rondella di sicurezza	Disco de seguridad	Locking washer		4	pc
9	5100035686	Controdado	Tuerca de seguridad	Safety nut		2	pc
10	5100070787	Cappa di protezione	Caperuza de protección	Protective cap		2	pc
15	5100022849	Bullone esagonale	Tornillo hexagonal	Hexagon screw		2	pc
16	5100016501	Rondella	Arandela	Washer		2	pc
17	5100012968	Rondella di sicurezza	Disco de seguridad	Locking washer		2	pc
60	5100023137	Supporti vibranti	Tope de caucho-metal	Rubber metal buffer		2	pc
61	5100023138	Supporti vibranti	Tope de caucho-metal	Rubber metal buffer		2	pc
62	5100023100	Anello	Anillo	Ring		2	pc
63	5100023063	Rondella	Arandela	Washer		2	pc
64	5100023163	Lamiera	Chapa	Metal plate		2	pc
65	5100023101	Rondella	Arandela	Washer		2	pc
66	5100023431	Rondella	Arandela	Washer		2	pc
67	5100023316	Rondella	Arandela	Washer		2	pc
68	5100034764	Bullone esagonale	Tornillo hexagonal	Hexagon screw		8	pc
69	5100012967	Rondella di sicurezza	Disco de seguridad	Locking washer		8	pc
74	5100023316	Rondella	Arandela	Washer		2	pc
75	5100023137	Supporti vibranti	Tope de caucho-metal	Rubber metal buffer		2	pc
76	5100023138	Supporti vibranti	Tope de caucho-metal	Rubber metal buffer		2	pc
77	5100023100	Anello	Anillo	Ring		2	pc
78	5100023063	Rondella	Arandela	Washer		2	pc
79	5100023163	Lamiera	Chapa	Metal plate		2	pc
80	5100023101	Rondella	Arandela	Washer		2	pc
81	5100023316	Rondella	Arandela	Washer		2	pc
82	5100034764	Bullone esagonale	Tornillo hexagonal	Hexagon screw		8	pc
83	5100012967	Rondella di sicurezza	Disco de seguridad	Locking washer		8	pc
84	5100035686	Controdado	Tuerca de seguridad	Safety nut		2	pc



Montaggio motore e pompa
Montaje de motor y bomba
Pump drive and engine assembly

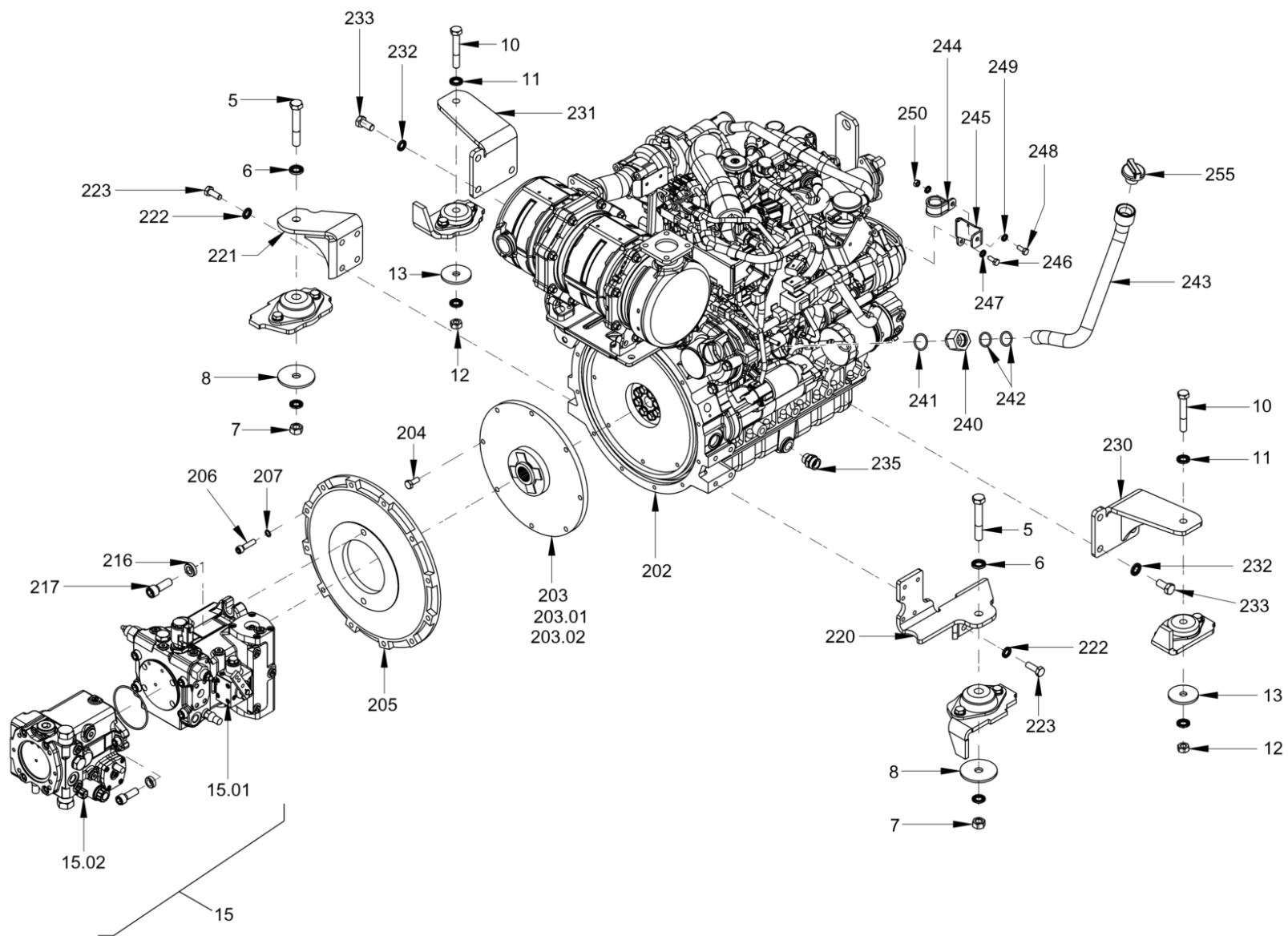

Montaggio motore e pompa
Montaje de motor y bomba
Pump drive and engine assembly

Item	Item no.	Descrizione	Descripción	Description	Information	Pc.	Unit
5	5100012502	Bullone esagonale	Tornillo hexagonal	Hexagon screw		2	pc
6	5100012969	Rondella di sicurezza	Disco de seguridad	Locking washer		4	pc
7	5100035686	Controdado	Tuerca de seguridad	Safety nut		2	pc
8	5100023316	Rondella	Arandela	Washer		2	pc
10	5100023003	Bullone esagonale	Tornillo hexagonal	Hexagon screw		2	pc
11	5100012972	Rondella di sicurezza	Disco de seguridad	Locking washer		4	pc
12	5100070788	Controdado	Tuerca de seguridad	Safety nut		2	pc
13	5100023502	Rondella	Arandela	Washer		2	pc
15	5100023302	Pompa a portata variabile	Bomba regolabile	Variable displacement pump	15.02	1	pc
15	5100070789	Pompa di regolazione	Bomba regolabile	Variable displacement pump	15.02	1	pc
15	5100070790	Gruppo pompa	Bomba	Pump unit		1	pc
15	5100070791	Gruppo pompa	Bomba	Pump unit		1	pc
15	5100070794	Pompa vibrante	Bomba de vibración	Vibration pump	15.01	1	pc
203	5100023325	Frizione centa	Acoplamiento centa	Centa coupling		1	pc
203	5100023652	Elemento elastico	Pieza elástica	Elastic part	203.01	1	pc
203	5100023653	Mozzo	Cubo	Hub	203.02	1	pc
204	5100012553	Bullone esagonale	Tornillo hexagonal	Hexagon screw		8	pc
205	5100023255	Flangia	Brida	Flange		1	pc
206	5100023379	Vite a testa cilindrica	Tornillo cilíndrico	Cheese-head screw		10	pc
207	5100013440	Rondella di sicurezza	Disco de seguridad	Locking washer		10	pc
216	5100023096	Rondella	Arandela	Washer		2	pc
217	5100070795	Vite a testa cilindrica	Tornillo cilíndrico	Cheese-head screw		2	pc
220	5100023293	Supporto	Soporte	Holder		1	pc
221	5100023292	Supporto	Soporte	Holder		1	pc
222	5100012968	Rondella di sicurezza	Disco de seguridad	Locking washer		8	pc
223	5100022925	Bullone esagonale	Tornillo hexagonal	Hexagon screw		8	pc
230	5100023291	Supporto	Fijación	Holder system		1	pc
231	5100070796	Supporto	Fijación	Holder system		1	pc
232	5100012972	Rondella di sicurezza	Disco de seguridad	Locking washer		6	pc
233	5100022864	Bullone esagonale	Tornillo hexagonal	Hexagon screw		6	pc
235	5100013471	Presa a vite dritta	Racor para enroscar recto	Straight screwed socket		1	pc
240	5100070797	Raccordo a vite	Junta roscada	Screw connection		1	pc
241	5100011737	Anello a o	Anillo toroïdal	O-ring seal		1	pc
242	5100025871	Anello a o	Anillo toroïdal	O-ring seal		2	pc
243	5100023252	Gomito di caricamento	Racor de llenado	Filler neck		1	pc
244	5100011470	Morsetto per tubi	Abrazadera	Pipe clip		1	pc

Montaggio motore e pompa
Montaje de motor y bomba
Pump drive and engine assembly

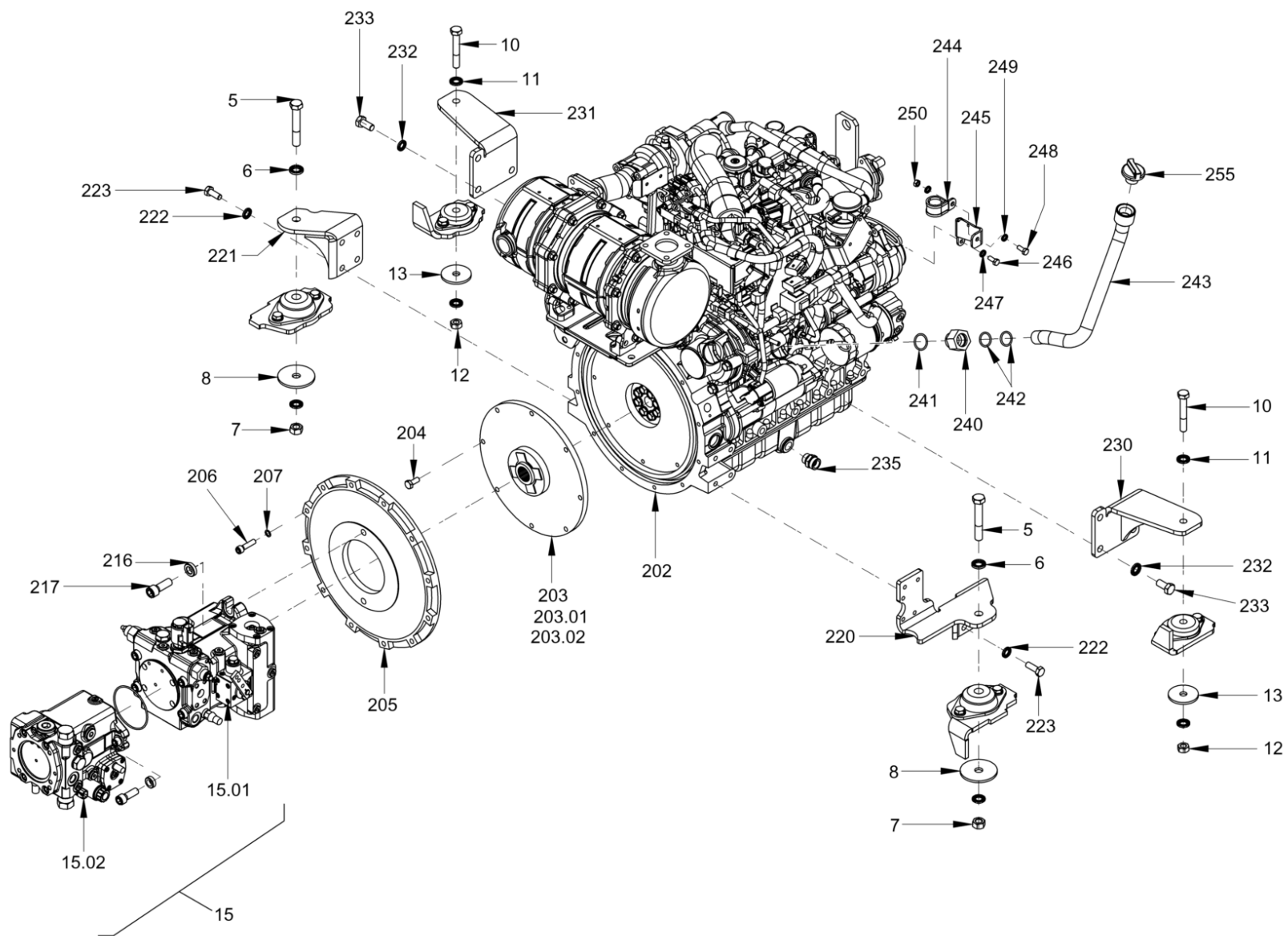

Montaggio motore e pompa
Montaje de motor y bomba
Pump drive and engine assembly

Item	Item no.	Descrizione	Descripción	Description	Information	Pc.	Unit
245	5100070798	Supporto	Soporte	Holder		1	pc
246	5100012517	Bullone esagonale	Tornillo hexagonal	Hexagon screw		2	pc
247	5100012966	Rondella di sicurezza	Disco de seguridad	Locking washer		2	pc
248	5100035087	Bullone esagonale	Tornillo hexagonal	Hexagon screw		1	pc
249	5100012966	Rondella di sicurezza	Disco de seguridad	Locking washer		2	pc
250	5100012546	Dado esagonale	Tuerca hexagonal	Hexagon nut		1	pc
255	5100022992	Coperchio	Tapa	Lid		1	pc



Montaggio motore e pompa
Montaje de motor y bomba
Pump drive and engine assembly

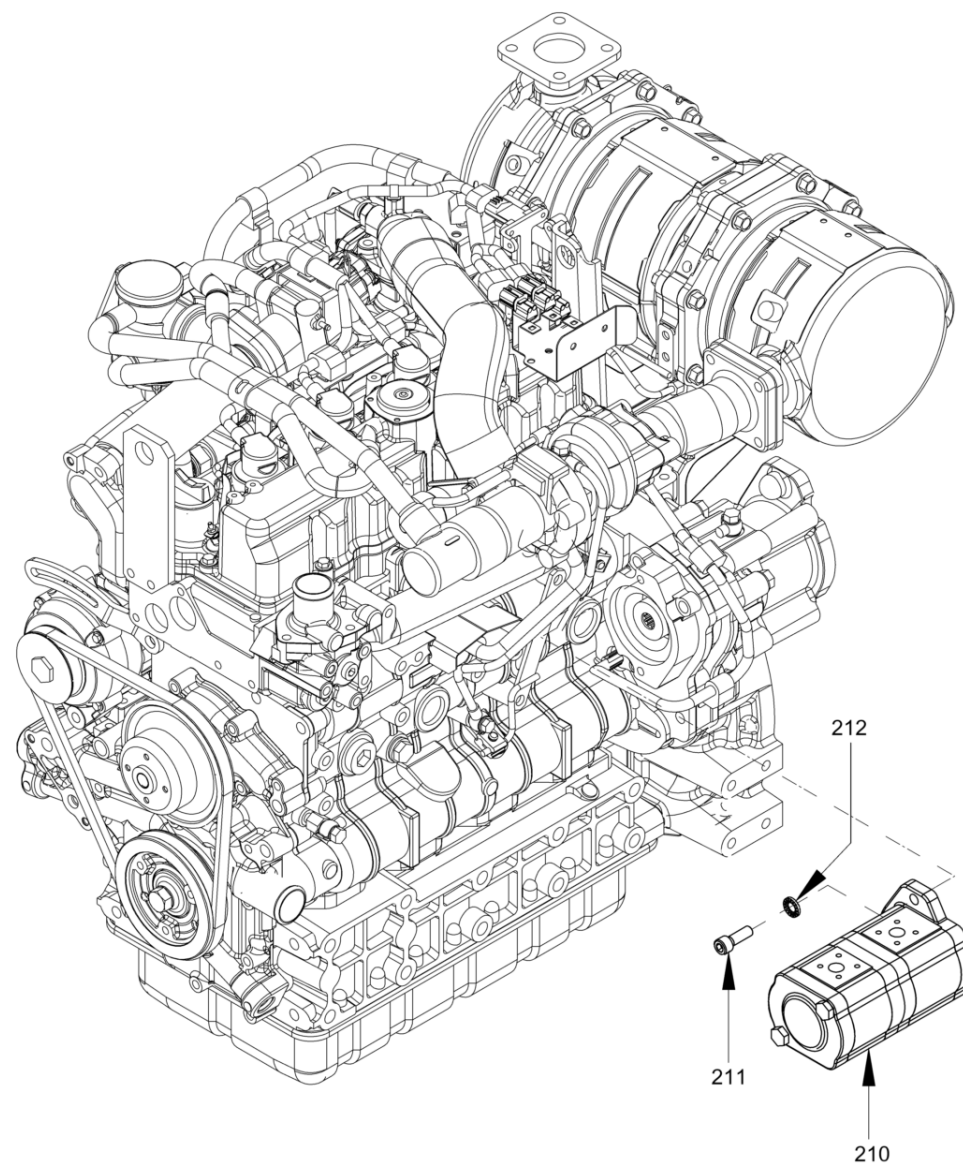

Montaggio motore e pompa
Montaje de motor y bomba
Pump drive and engine assembly

Item	Item no.	Descrizione	Descripción	Description	Information	Pc.	Unit
210	5100023305	Pompa tandem	Bomba tándem	Tandem pump		1	pc
211	5100023378	Vite a testa cilindrica	Tornillo cilíndrico	Cheese-head screw		2	pc
212	5100013440	Rondella di sicurezza	Disco de seguridad	Locking washer		2	pc



Montaggio motore e pompa
Montaje de motor y bomba
Pump drive and engine assembly

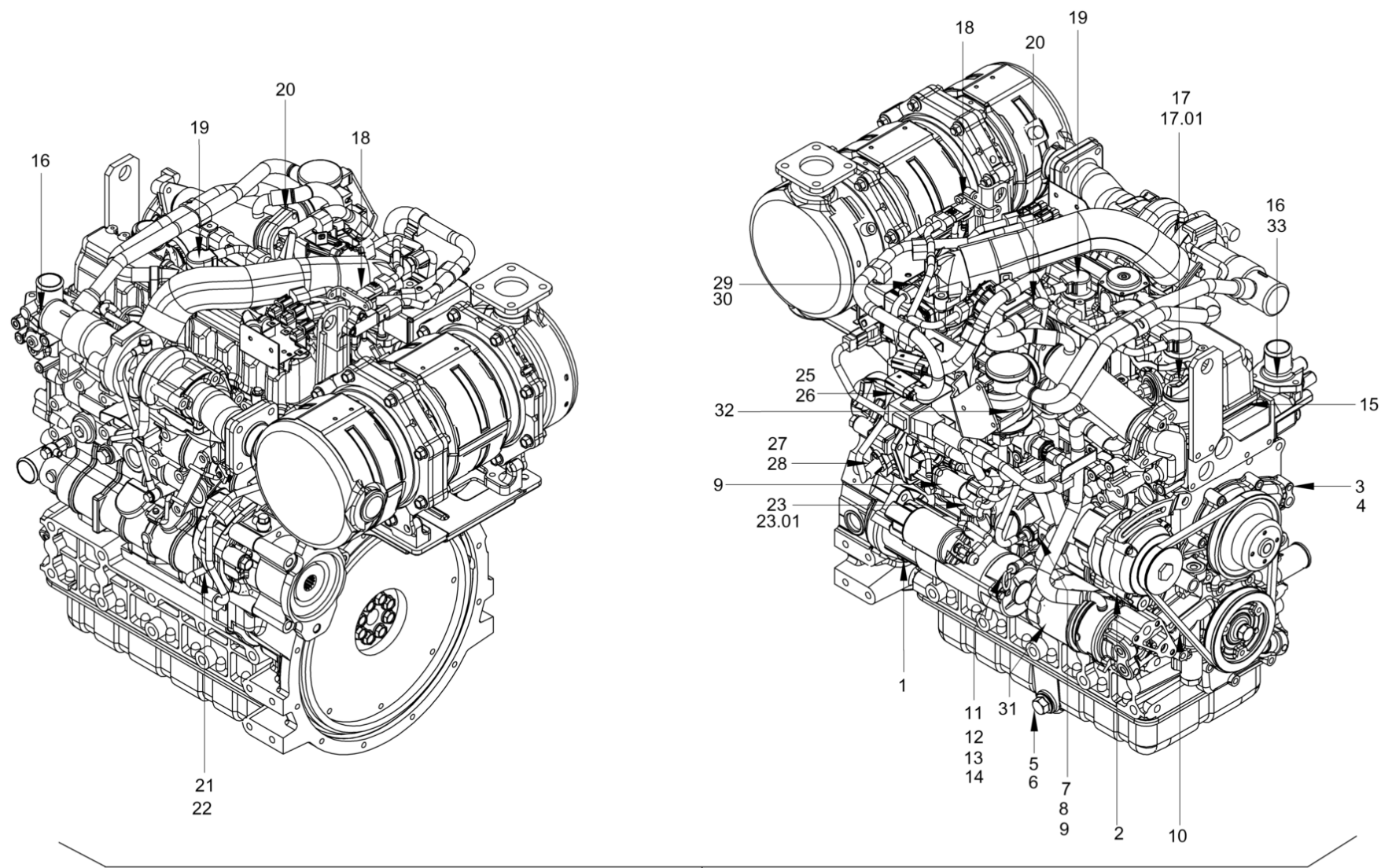

100



Montaggio motore e pompa
Montaje de motor y bomba
Pump drive and engine assembly

Item	Item no.	Descrizione	Descripción	Description	Information	Pc.	Unit
1	5100025010	Dispositivo di avviamento	Arrancador	Starter		1	pc
2	5100023269	Alternatore trifase	Dinamo de corriente trifásica	Alternator		1	pc
3	5100023683	Pompa dell'acqua	Bomba de agua	Water pump		1	pc
4	5100023684	Guarnizione	Junta	Sealing		1	pc
5	5100023663	Guarnizione	Anillo de junta	Sealing ring		2	pc
6	5100023664	Vite di bloccaggio	Tornillo de cierre	Locking screw		2	pc
7	5100023676	Pressostato olio	Interr. pres aceite, ac. motor	Engine oil pressure switch		1	pc
8	5100023681	Guarnizione	Anillo de junta	Sealing ring		1	pc
9	5100070799	Valvola	Válvula	Valve		1	pc
10	5100023634	Cinghia di distribuzione	Correa trapezoidal dentada	Toothed v-belt		1	pc
11	5100023667	Tubo guida	Tubo guía	Guide tube		1	pc
12	5100023666	Astina di livello dell'olio	Varilla para nivel de aceite	Oil dipstick		1	pc
13	5100023665	Anello a o	Anillo toroidal	O-ring seal		1	pc
14	5100023668	Vite	Tornillo	Screw		1	pc
15	5100023635	Guarnizione, coperchio della valvola	Junta, tapa de la válvula	Seal, valve cover		1	pc
16	5100070800	Termostato	Termostato	Thermostat		1	pc
17	5100023669	Kit copertura	Kit tapa	Kit cover		1	pc
17	5100023507	Anello a o	Anillo toroidal	O-ring seal	17.01	1	pc
18	5100023675	Sensore	Sensor	Sensor		1	pc
19	5100023672	Candeletta	Bujía de arranque	Heater plug		4	pc
20	5100070801	Valvola limitatrice di pressione	Válvula limitadora de presión	Pressure-relief valve		1	pc
21	5100023323	Sensore	Sensor	Sensor		1	pc
22	5100023673	Anello a o	Anillo toroidal	O-ring seal		1	pc
23	5100023670	Anello a o	Anillo toroidal	O-ring seal	23.01	1	pc
23	5100023671	Sensore di temperatura	Sonda de temperatura	Temperature probe		1	pc
25	5100023324	Sensore	Sensor	Sensor		1	pc
26	5100023681	Guarnizione	Anillo de junta	Sealing ring		1	pc
27	5100023679	Sensore di temperatura	Sonda de temperatura	Temperature probe		1	pc
28	5100023680	Anello a o	Anillo toroidal	O-ring seal		1	pc
29	5100023322	Sensore	Sensor	Sensor		1	pc
30	5100023674	Guarnizione	Anillo de junta	Sealing ring		1	pc
31	5100025896	Cartuccia filtrante, olio lubrificante	Cartucho filtro, aceite lubr.	Filter cartridge, lubric. oil		1	pc
32	5100024983	Inserto filtro	Cartucho de filtro	Filter insert		1	pc
33	5100070802	Piatto	Placa	Plate		1	pc
100	5100070803	Motore diesel	Motor diesel	Diesel engine		1	pc

Impianto di alimentazione del carburante
Sistema de combustible
Fuel system

Item	Item no.	Descrizione	Descripción	Description	Information	Pc.	Unit
5	5100013236	Guarnizione	Junta	Seal	5.01	1	pc
5	5100023297	Indicatore di carburante	Sensor de reservas	Fuel gauge		1	pc
6	5100013502	Guarnizione	Anillo de junta	Sealing ring		6	pc
7	5100011443	Vite a testa cilindrica	Tornillo cilíndrico	Cheese-head screw		6	pc
8	5100023170	Vite di bloccaggio	Tornillo de cierre	Locking screw		1	pc
11	5100013179	Fascetta stringitubo	Abrazadera	Hose clip		6	pc
12	5100012608	Bullone esagonale	Tornillo hexagonal	Hexagon screw		2	pc
13	5100012965	Rondella di sicurezza	Disco de seguridad	Locking washer		2	pc
15	5100025887	Presa a vite diritta	Racor para enroscar recto	Straight screwed socket		1	pc
16	5100024988	Vite di bloccaggio	Tornillo de cierre	Locking screw		1	pc
19	5100013472	Presa a vite diritta	Racor para enroscar recto	Straight screwed socket		3	pc
20	5100023453	Carburante-filtro	Filtro de combustible	Fuel filter		1	pc
21	5100023444	Prefiltro carburante	Cartucho de filtro	Fuel filter cartridge		1	pc
22	5100012523	Bullone esagonale	Tornillo hexagonal	Hexagon screw		3	pc
23	5100012967	Rondella di sicurezza	Disco de seguridad	Locking washer		6	pc
24	5100012547	Dado esagonale	Tuerca hexagonal	Hexagon nut		3	pc
25	5100011918	Rondella dent.	Arandela elástica dentada	Serrated lock washer		3	pc
26	5100023419	Bullone esagonale	Tornillo hexagonal	Hexagon screw		1	pc
27	5100023124	Dado esagonale	Tuerca hexagonal	Hexagonal nut		1	pc
30	5100023593	Tubo flessibile	Manguera	Hose		1	pc
31	5100023594	Tubo flessibile	Manguera	Hose		1	pc
32	5100023594	Tubo flessibile	Manguera	Hose		1	pc
33	5100070806	Tubo flessibile	Manguera	Hose		1	pc
34	5100023597	Tubo flessibile	Manguera	Hose		1	pc
35	5100023485	Pompa del carburante	Bomba de fuel oil	Fuel pump		1	pc
36	5100070807	Supporto	Soporte	Holder		1	pc
40	5100012034	Inserto filettato	Pieza roscada	Threaded insert		1	pc
41	5100011829	Tappo del serbatoio, con lucchetto	Tapa del depósito c/ cerradura	Tank cap, with lock		1	pc
41	5100013557	Chiave	Llave	Key	41.01	1	pc
43	5100022972	Anello a o	Anillo toroidal	O-ring seal		1	pc
44	5100022971	Coperchio	Tapa	Lid		1	pc
45	5100048692	Vite prigioniera	Espárrago	Stud screw		4	pc
46	5100012967	Rondella di sicurezza	Disco de seguridad	Locking washer		8	pc
47	5100012547	Dado esagonale	Tuerca hexagonal	Hexagon nut		4	pc



Filtro carburante
Filtro de combustible
Fuel filter

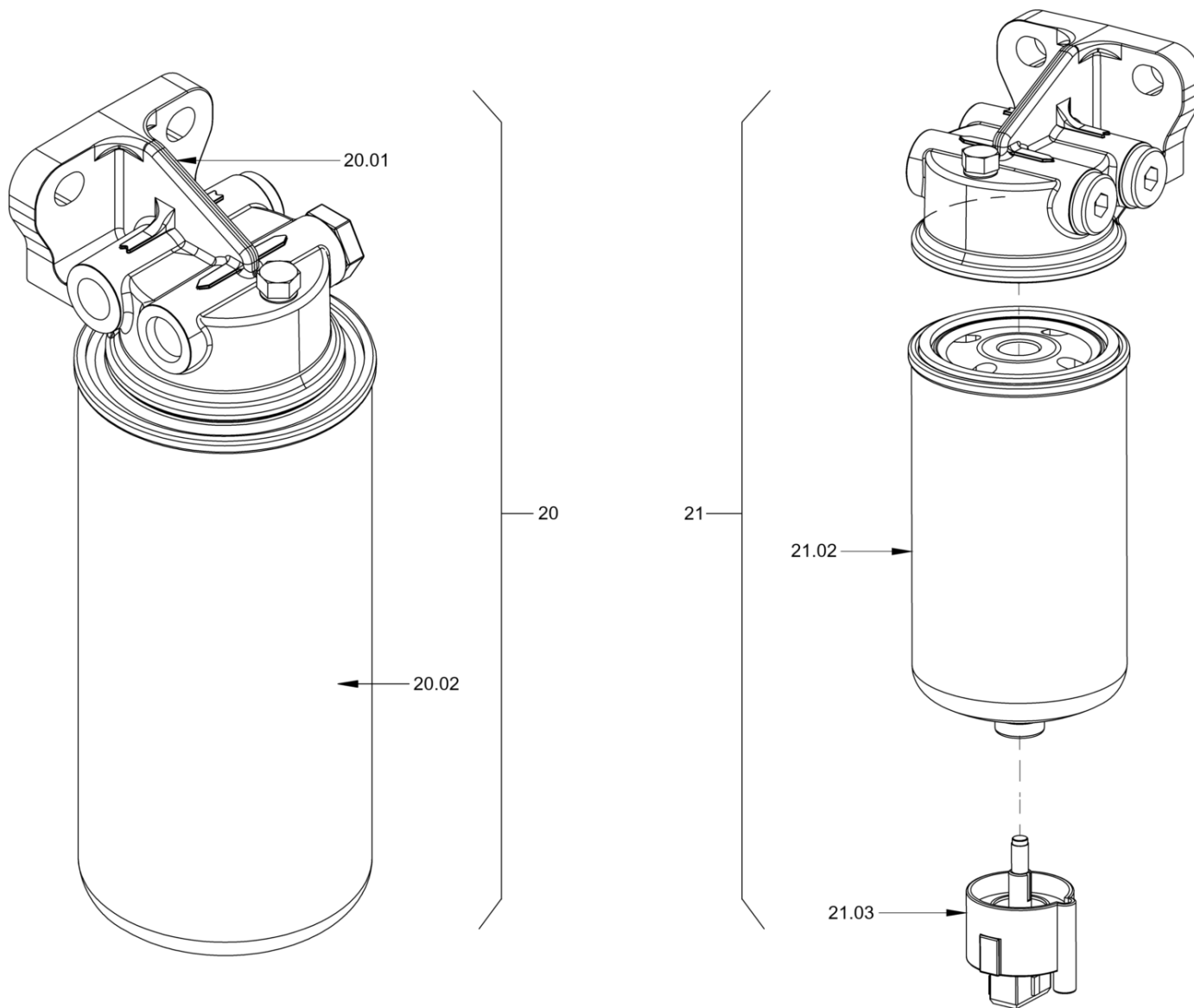

Filtro carburante
Filtro de combustible
Fuel filter

Item	Item no.	Descrizione	Descripción	Description	Information	Pc.	Unit
20	5100023253	Testa del filtro	Cabezal del filtro	Filter cover	20.01	1	pc
20	5100023254	Cartuccia filtrante, carburante	Cartucho filtro, combustible	Filter cartridge, fuel	20.02	1	pc
20	5100023453	Carburante-filtro	Filtro de combustible	Fuel filter		1	pc
21	5100023444	Prefiltro carburante	Cartucho de filtro	Fuel filter cartridge		1	pc
21	5100023445	Cartuccia filtrante, carburante	Cartucho filtro, combustible	Filter cartridge, fuel	21.02	1	pc
21	5100023465	Sensore	Sensor	Sensor	21.03	1	pc



Impianto filtro dell'aria
Sistema filtro de aire
Air filter system

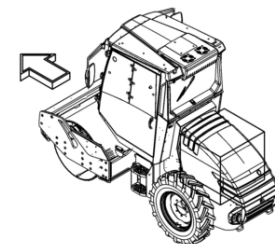
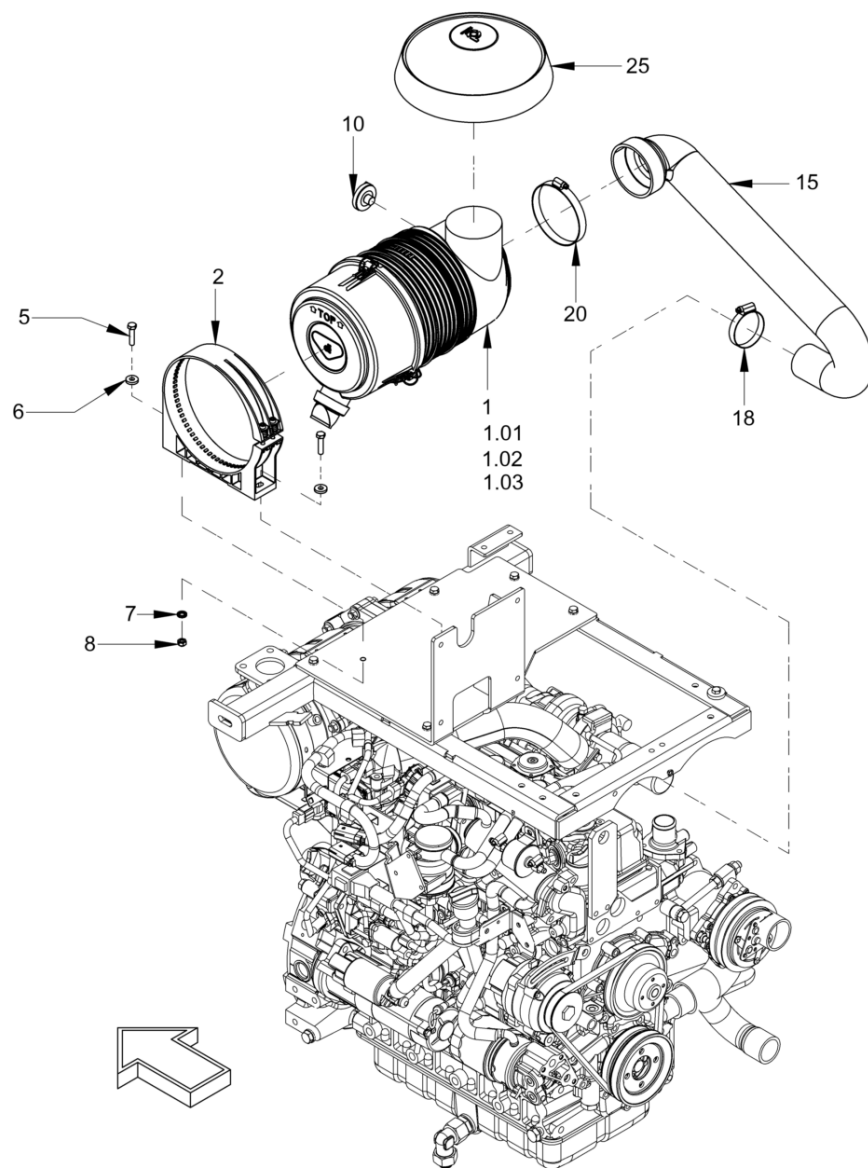

Impianto filtro dell'aria
Sistema filtro de aire
Air filter system

Item	Item no.	Descrizione	Descripción	Description	Information	Pc.	Unit
1	5100023133	Filtro aria	Filtro de aire	Air filter		1	pc
1	5100023134	Cartuccia filtrante	Cartucho del filtro	Filter cartridge	1.01	1	pc
1	5100023135	Cartuccia di sicurezza	Cartucho filtro de seguridad	Safety filter cartridge	1.02	1	pc
1	5100023165	Valvola deflettore	Válvula de descarga de polvo	Dust discharge valve	1.03	1	pc
2	5100023136	Supporto	Soporte	Holder		1	pc
5	5100035308	Bullone esagonale	Tornillo hexagonal	Hexagon screw		2	pc
6	5100013257	Rondella	Arandela	Washer		2	pc
7	5100012966	Rondella di sicurezza	Disco de seguridad	Locking washer		2	pc
8	5100012546	Dado esagonale	Tuerca hexagonal	Hexagon nut		2	pc
10	5100013370	Vacuostato, filtro dell'aria	Interr. depresión, filtro aire	Pressure switch, air filter		1	pc
15	5100070808	Tubo per l'aria	Manguera de aire	Air hose		1	pc
18	5100013403	Fascetta stringitubo	Abrazadera	Hose clip		1	pc
20	5100022865	Collare su soffietto	Abrazadera	Hose clamp		1	pc
25	5100023493	Protezione	Protección contra lluvia	Rain cap		1	pc

Impianto di scarico
Sistema de escape
Exhaust system

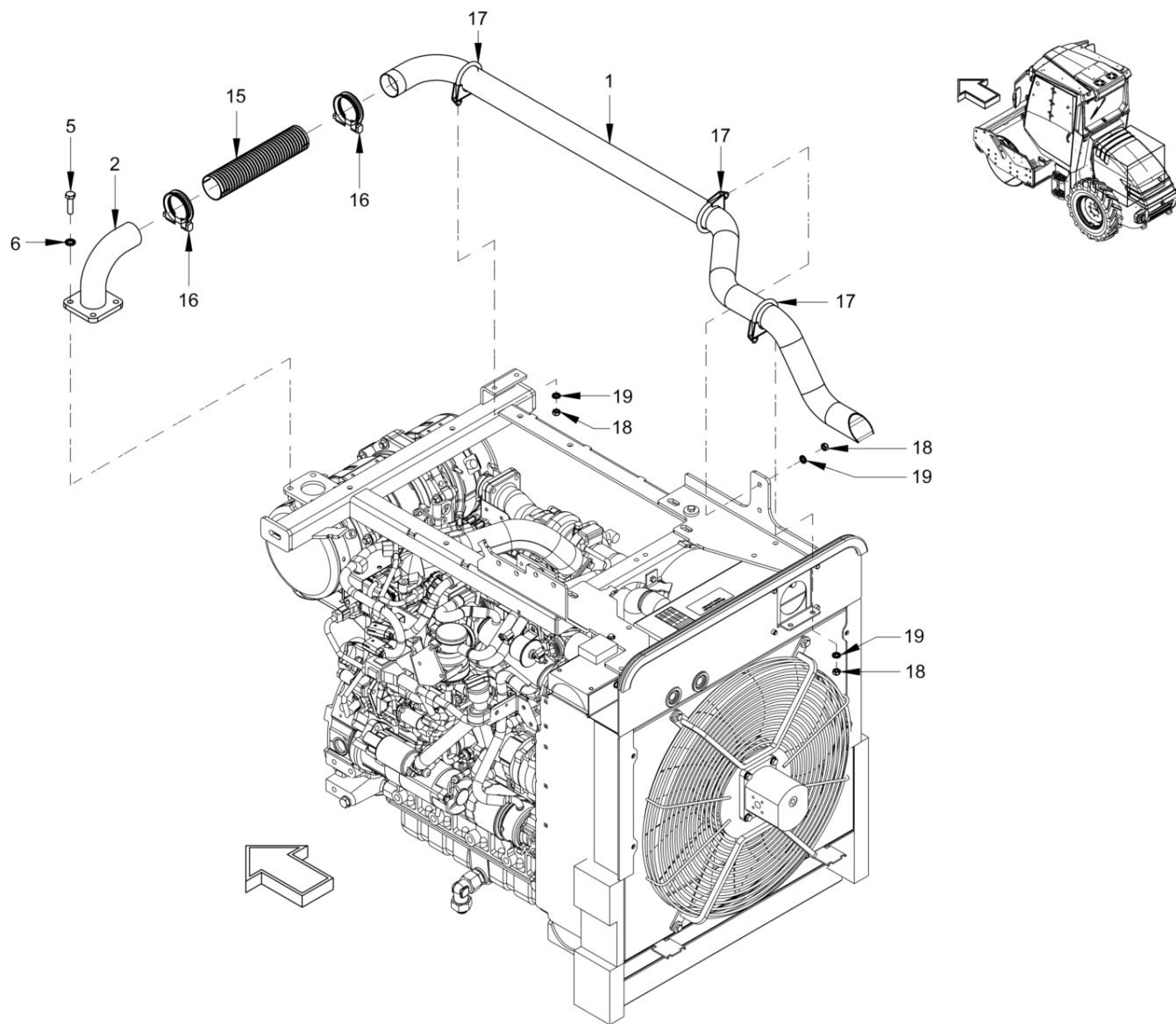

Impianto di scarico
Sistema de escape
Exhaust system

Item	Item no.	Descrizione	Descripción	Description	Information	Pc.	Unit
1	5100023582	Tubo di scarico	Tubo de escape	Flue gas pipe		1	pc
2	5100023312	Tubo scarico	Tubo de escape	Exhaust pipe		1	pc
5	5100012553	Bullone esagonale	Tornillo hexagonal	Hexagon screw		4	pc
6	5100012967	Rondella di sicurezza	Disco de seguridad	Locking washer		4	pc
15	5100023313	Tubo gas di scarico	Manguera de gases de escape	Exhaust gas hose		1	pc
16	5100023001	Morsetto per tubi	Abrazadera	Pipe clip		2	pc
17	5100023296	Morsetto della staffa	Abrazadera semirredonda	Strap clip		3	pc
18	5100024980	Dado esagonale	Tuerca hexagonal	Hexagonal nut		6	pc
19	5100012966	Rondella di sicurezza	Disco de seguridad	Locking washer		6	pc



Post-trattamento del gas di scarico
Tratamiento posterior de gases de escape
Exhaust aftertreatment

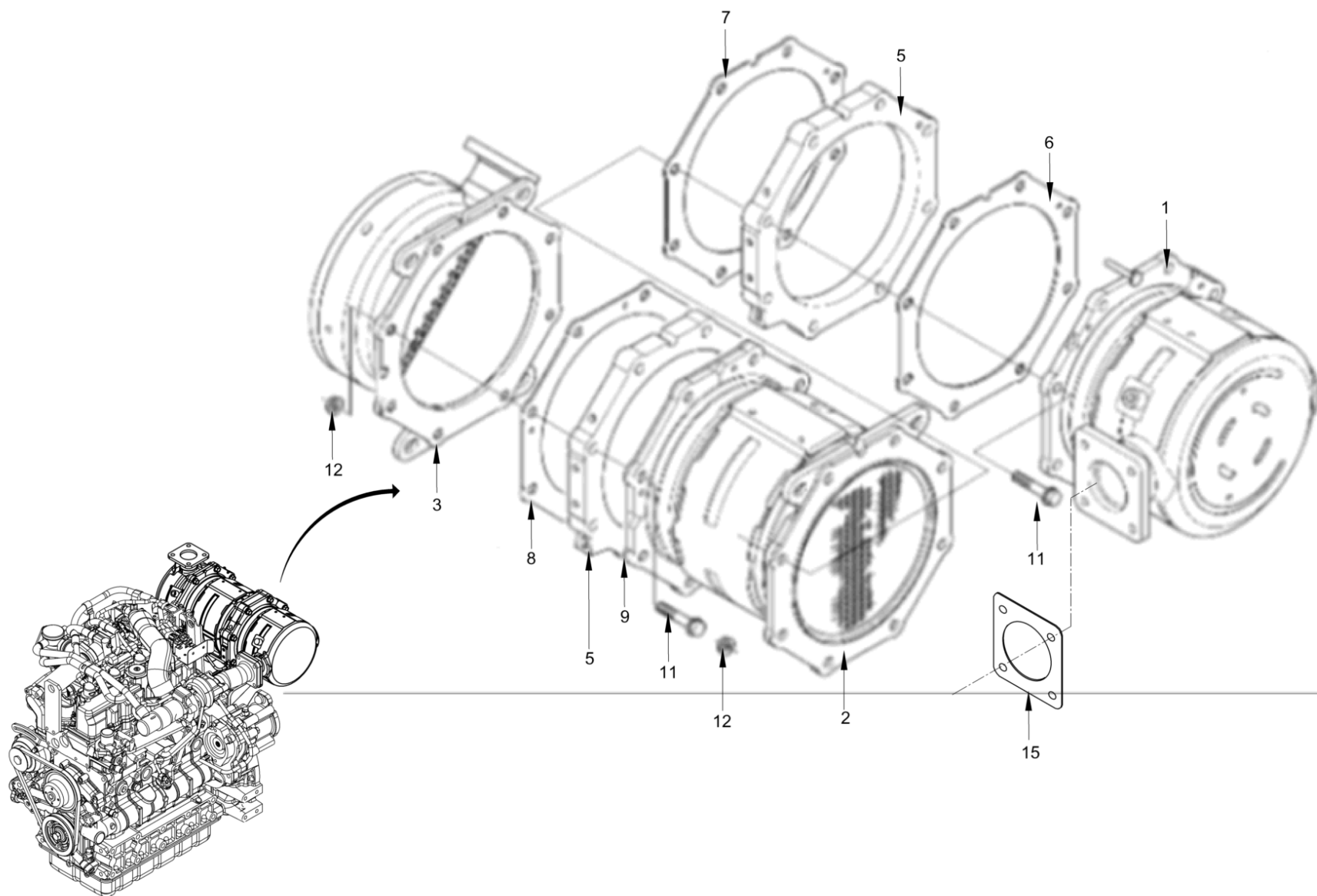

Post-trattamento del gas di scarico
Tratamiento posterior de gases de escape
Exhaust aftertreatment

Item	Item no.	Descrizione	Descripción	Description	Information	Pc.	Unit
1	5100070809	Filtro anti-particolato	Filtro de partículas	Particulate filter		1	pc
2	5100070810	Filtro anti-particolato	Filtro de partículas	Particulate filter		1	pc
3	5100070811	Cassaforma	Carcasa	Housing		1	pc
5	5100023696	Pezzo intermedio	Pieza intermedia	Intermediate piece		2	pc
6	5100023688	Guarnizione	Junta	Sealing		1	pc
7	5100023688	Guarnizione	Junta	Sealing		1	pc
8	5100023688	Guarnizione	Junta	Sealing		1	pc
9	5100023688	Guarnizione	Junta	Sealing		8	pc
11	5100023698	Vite	Tornillo	Screw		8	pc
12	5100023699	Dado	Tuerca	Nut		8	pc
15	5100070812	Guarnizione	Junta	Sealing		1	pc



Post-trattamento del gas di scarico
Tratamiento posterior de gases de escape
Exhaust aftertreatment

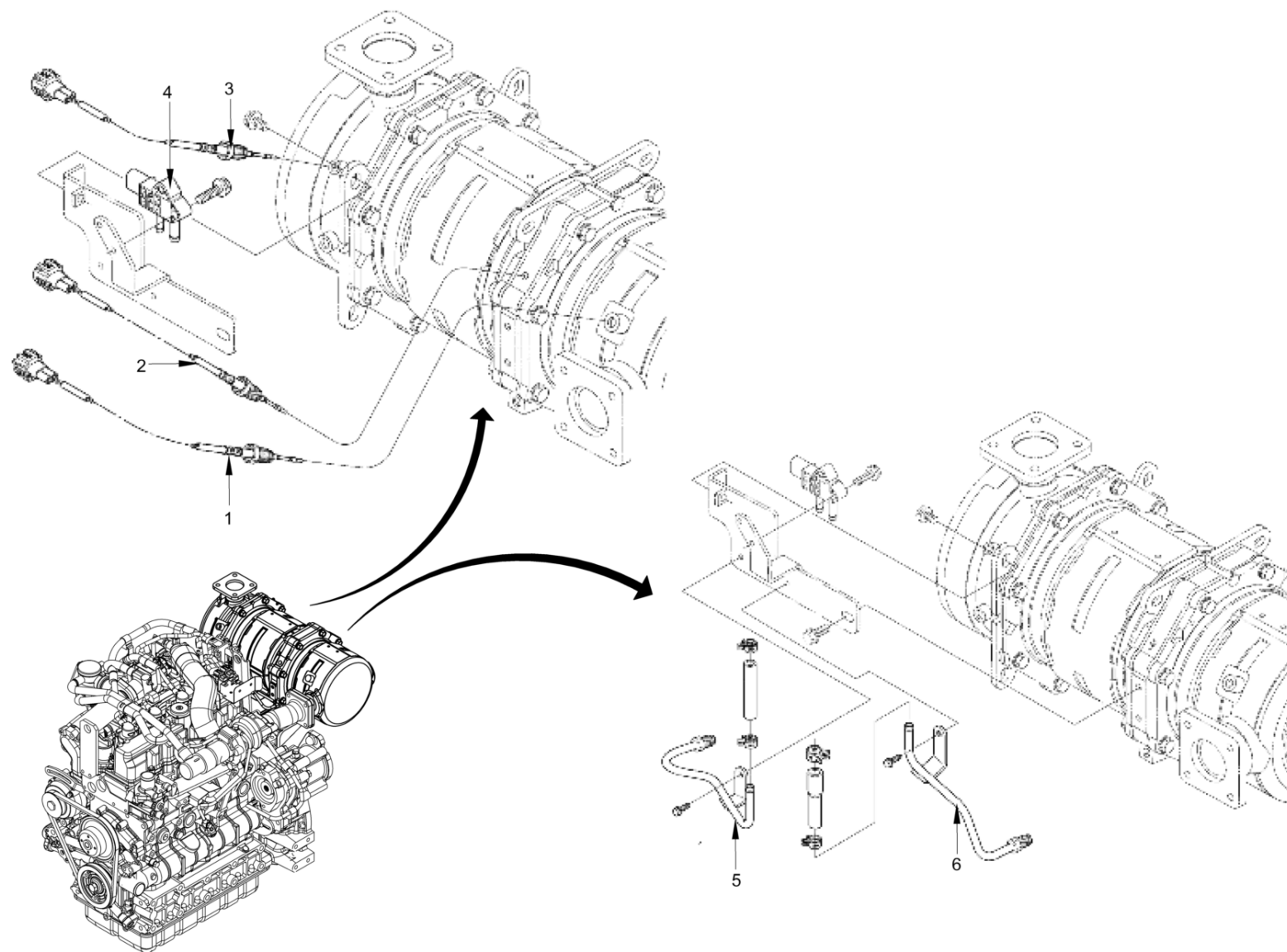

Post-trattamento del gas di scarico
Tratamiento posterior de gases de escape
Exhaust aftertreatment

Item	Item no.	Descrizione	Descripción	Description	Information	Pc.	Unit
1	5100023691	Sensore di temperatura	Sonda de temperatura	Temperature probe		1	pc
2	5100023692	Sensore di temperatura	Sonda de temperatura	Temperature probe		1	pc
3	5100023693	Sensore di temperatura	Sonda de temperatura	Temperature probe		1	pc
4	5100023694	Sensore di temperatura	Sonda de temperatura	Temperature probe		1	pc
5	5100023689	Tubo	Tubo	Pipe		1	pc
6	5100023690	Tubo	Tubo	Pipe		1	pc



Raffreddamento (motore/olio idraulico)
Refrigeración (motor/aceite hidráulico)
Cooling (engine/hydraulic oil)

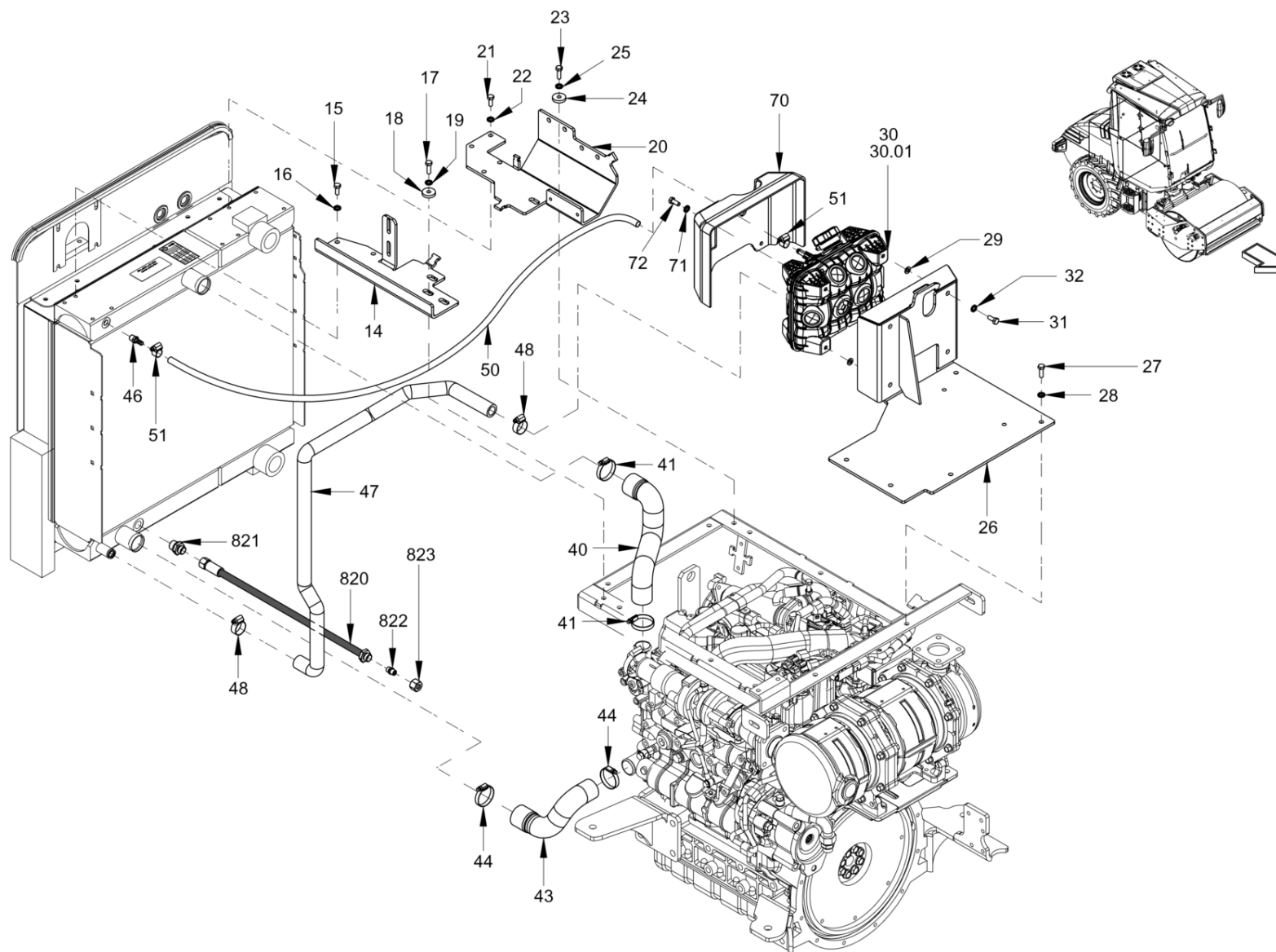

Raffreddamento (motore/olio idraulico)
Refrigeración (motor/aceite hidráulico)
Cooling (engine/hydraulic oil)

Item	Item no.	Descrizione	Descripción	Description	Information	Pc.	Unit
14	5100023367	Supporto	Soporte	Holder		1	pc
15	5100012517	Bullone esagonale	Tornillo hexagonal	Hexagon screw		4	pc
16	5100012966	Rondella di sicurezza	Disco de seguridad	Locking washer		4	pc
17	5100013510	Bullone esagonale	Tornillo hexagonal	Hexagon screw		3	pc
18	5100022953	Rondella	Arandela	Washer		3	pc
19	5100012966	Rondella di sicurezza	Disco de seguridad	Locking washer		3	pc
20	5100070813	Supporto	Soporte	Holder		1	pc
21	5100012517	Bullone esagonale	Tornillo hexagonal	Hexagon screw		4	pc
22	5100012966	Rondella di sicurezza	Disco de seguridad	Locking washer		4	pc
23	5100013510	Bullone esagonale	Tornillo hexagonal	Hexagon screw		3	pc
24	5100022953	Rondella	Arandela	Washer		3	pc
25	5100012966	Rondella di sicurezza	Disco de seguridad	Locking washer		3	pc
26	5100023368	Supporto	Soporte	Holder		1	pc
27	5100013510	Bullone esagonale	Tornillo hexagonal	Hexagon screw		5	pc
28	5100012966	Rondella di sicurezza	Disco de seguridad	Locking washer		5	pc
29	5100012938	Rondella	Arandela	Washer		4	pc
30	5100023482	Coperchio del serbatoio	Tapa del depósito	Tank cap	30.01	1	pc
30	5100023389	Serbatoio di compensazione	Depósito de compensación	Compensator tank		1	pc
31	5100012517	Bullone esagonale	Tornillo hexagonal	Hexagon screw		4	pc
32	5100012966	Rondella di sicurezza	Disco de seguridad	Locking washer		4	pc
40	5100023435	Tubo acqua di raffreddamento	Manga agua de refrigeracion	Cooling-water hose		1	pc
41	5100011643	Fascetta stringitubo	Abrazadera	Hose clip		2	pc
43	5100023434	Tubo acqua di raffreddamento	Manga agua de refrigeracion	Cooling-water hose		1	pc
44	5100011643	Fascetta stringitubo	Abrazadera	Hose clip		2	pc
46	5100012788	Tubetto flessibile	Boquilla de la manguera	Hose nozzle		1	pc
47	5100023498	Tubo acqua di raffreddamento	Manga agua de refrigeracion	Cooling-water hose		1	pc
48	5100013452	Fascetta stringitubo	Abrazadera	Hose clip		2	pc
50	5100013217	Tubo acqua di raffreddamento	Manga agua de refrigeracion	Cooling-water hose		0.6	m
51	5100013179	Fascetta stringitubo	Abrazadera	Hose clip		2	pc
70	5100070814	Calotta	Gancho	Hood		1	pc
71	5100012517	Bullone esagonale	Tornillo hexagonal	Hexagon screw		2	pc
72	5100012966	Rondella di sicurezza	Disco de seguridad	Locking washer		2	pc
820	5100070816	Tubo flessibile	Manguera	Hose		1	pc
821	5100013433	Presa a vite dritta	Racor para enroscar recto	Straight screwed socket		1	pc
822	5100023004	Tappo a vite	Tapón de cierre	Filler cap		1	pc
823	5100022841	Dado di giunzione	Tuerca roscada	Union nut		1	pc



Raffreddamento (motore/olio idraulico)
Refrigeración (motor/aceite hidráulico)
Cooling (engine/hydraulic oil)

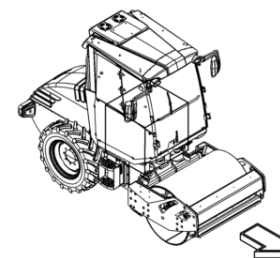
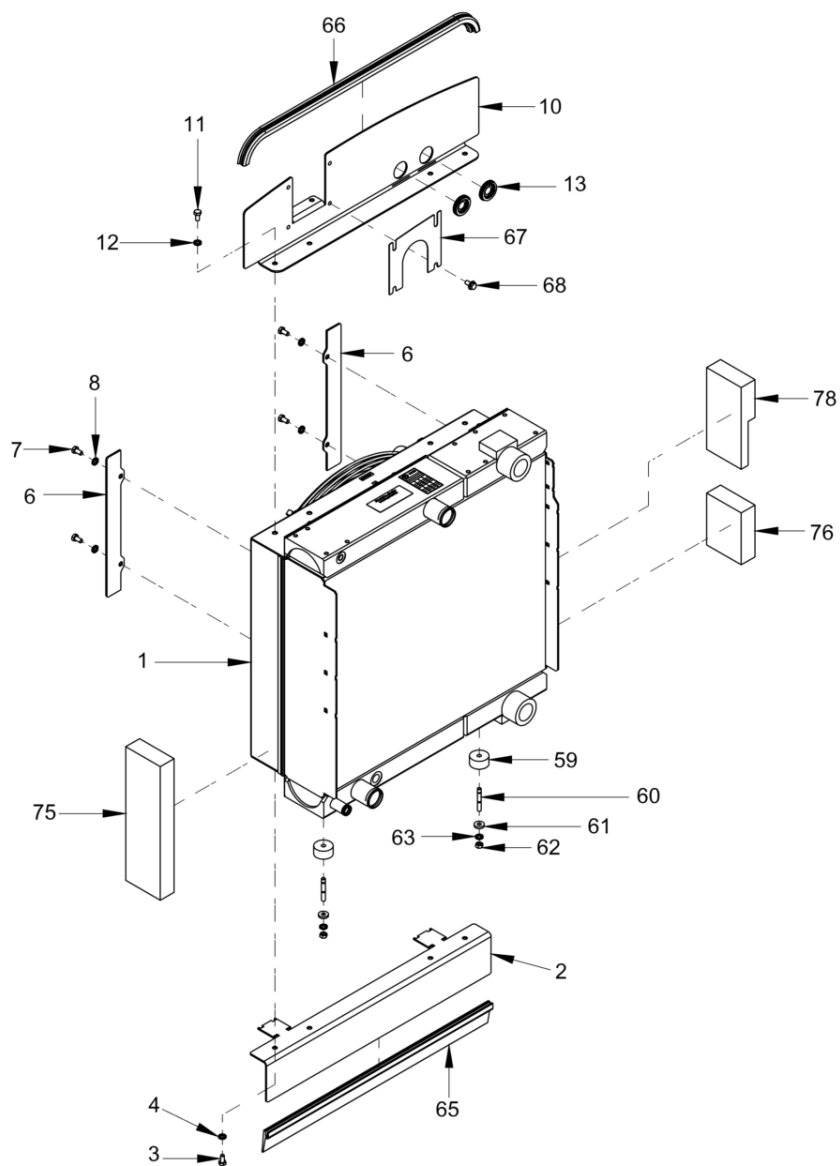

Raffreddamento (motore/olio idraulico)
Refrigeración (motor/aceite hidráulico)
Cooling (engine/hydraulic oil)

Item	Item no.	Descrizione	Descripción	Description	Information	Pc.	Unit
1	5100070818	Dispositivo di raffreddamento	Refrigerador	Cooler		1	pc
2	5100023300	Lamiera	Chapa	Metal plate		1	pc
3	5100012515	Bullone esagonale	Tornillo hexagonal	Hexagon screw		4	pc
4	5100012966	Rondella di sicurezza	Disco de seguridad	Locking washer		4	pc
6	5100023299	Lamiera	Chapa	Metal plate		2	pc
7	5100012515	Bullone esagonale	Tornillo hexagonal	Hexagon screw		4	pc
8	5100012966	Rondella di sicurezza	Disco de seguridad	Locking washer		4	pc
10	5100023622	Lamiera	Chapa	Metal plate		1	pc
11	5100012515	Bullone esagonale	Tornillo hexagonal	Hexagon screw		4	pc
12	5100012966	Rondella di sicurezza	Disco de seguridad	Locking washer		4	pc
13	5100023040	Passacavo	Boquilla de cable	Cable support sleeve		2	pc
59	5100023363	Distanziatore	Pieza distanciadora	Distance piece		2	pc
60	5100040585	Vite prigioniera	Espárrago	Stud screw		2	pc
61	5100013094	Rondella	Arandela	Washer		2	pc
62	5100012546	Dado esagonale	Tuerca hexagonal	Hexagon nut		2	pc
63	5100012966	Rondella di sicurezza	Disco de seguridad	Locking washer		2	pc
65	5100022973	Profilo di tenuta	Perfil de impermeabilización	Sealing profile		0.65	m
66	5100023217	Profilo di tenuta	Perfil de impermeabilización	Sealing profile		0.7	m
67	5100023623	Lamiera	Chapa	Metal plate		1	pc
68	5100012498	Vite di sicurezza	Tornillo de seguridad	Safety screw		4	pc
75	5100023494	Pannello isolante	Placa aislante	Insulation plate		1	pc
76	5100023495	Pannello isolante	Placa aislante	Insulation plate		1	pc
78	5100023496	Pannello isolante	Placa aislante	Insulation plate		1	pc



Raffreddamento (motore/olio idraulico)
Refrigeración (motor/aceite hidráulico)
Cooling (engine/hydraulic oil)

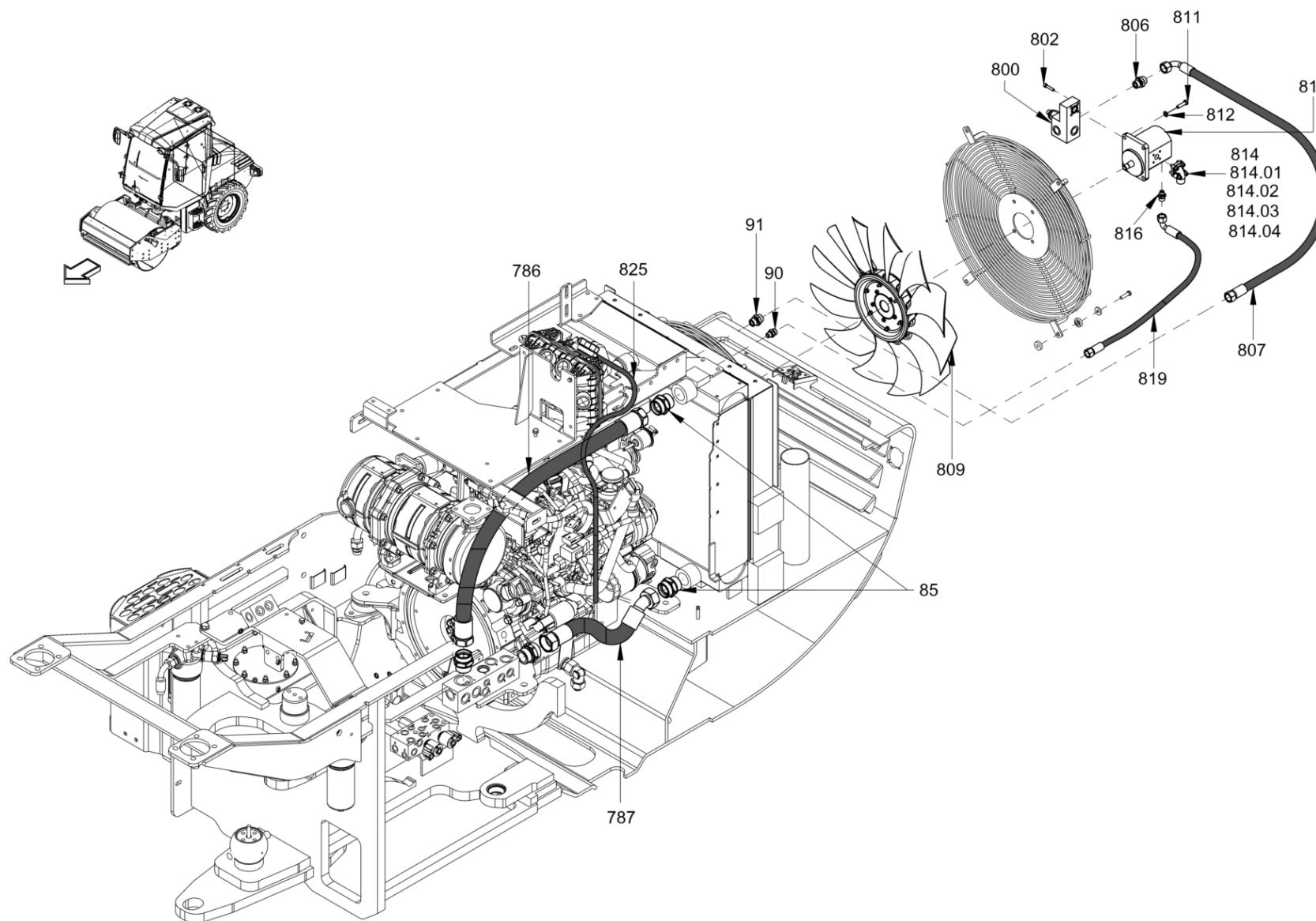

Raffreddamento (motore/olio idraulico)
Refrigeración (motor/aceite hidráulico)
Cooling (engine/hydraulic oil)

Item	Item no.	Descrizione	Descripción	Description	Information	Pc.	Unit
85	5100023155	Presa a vite diritta	Racor para enroscar recto	Straight screwed socket		2	pc
90	5100013433	Presa a vite diritta	Racor para enroscar recto	Straight screwed socket		1	pc
91	5100013476	Presa a vite diritta	Racor para enroscar recto	Straight screwed socket		1	pc
786	5100023401	Tubo flessibile	Manguera	Hose		1	pc
787	5100023400	Tubo flessibile	Manguera	Hose		1	pc
800	5100023524	Valvola limitatrice della pressione	Válvula limitadora de presión	Pressure-relief valve		1	pc
802	5100011481	Vite a testa cilindrica	Tornillo cilíndrico	Cheese-head screw		4	pc
806	5100013476	Presa a vite diritta	Racor para enroscar recto	Straight screwed socket		1	pc
807	5100011545	Tubo flessibile	Manguera	Flexible tubing		1	pc
809	5100023647	Ventole	Ventilador	Fan		1	pc
810	5100023534	Pompa oleodyn. ad ingranaggi	Motor del engranaje	Gear motor		1	pc
811	5100013510	Bullone esagonale	Tornillo hexagonal	Hexagon screw		4	pc
812	5100012966	Rondella di sicurezza	Disco de seguridad	Locking washer		4	pc
814	5100012216	Connessione a vite con flangia a gomito	Racor de la brida angular	Angle flange screwing		2	pc
814	5100012723	Vite a testa cilindrica	Tornillo cilíndrico	Cheese-head screw	814.02	2	pc
814	5100012942	Rondella elastica	Arandela elástica	Spring ring	814.04	4	pc
814	5100013189	Vite a testa cilindrica	Tornillo cilíndrico	Cheese-head screw	814.03	2	pc
814	5100013612	Anello a o	Anillo toroïdal	O-ring seal	814.01	1	pc
816	5100013447	Presa a vite diritta	Racor para enroscar recto	Straight screwed socket		1	pc
819	5100023455	Tubo flessibile	Manguera	Hose		1	pc
825	5100013217	Tubo acqua di raffreddamento	Manga agua de refrigeracion	Cooling-water hose		0.9	m



Raffreddamento (motore/olio idraulico)
Refrigeración (motor/aceite hidráulico)
Cooling (engine/hydraulic oil)

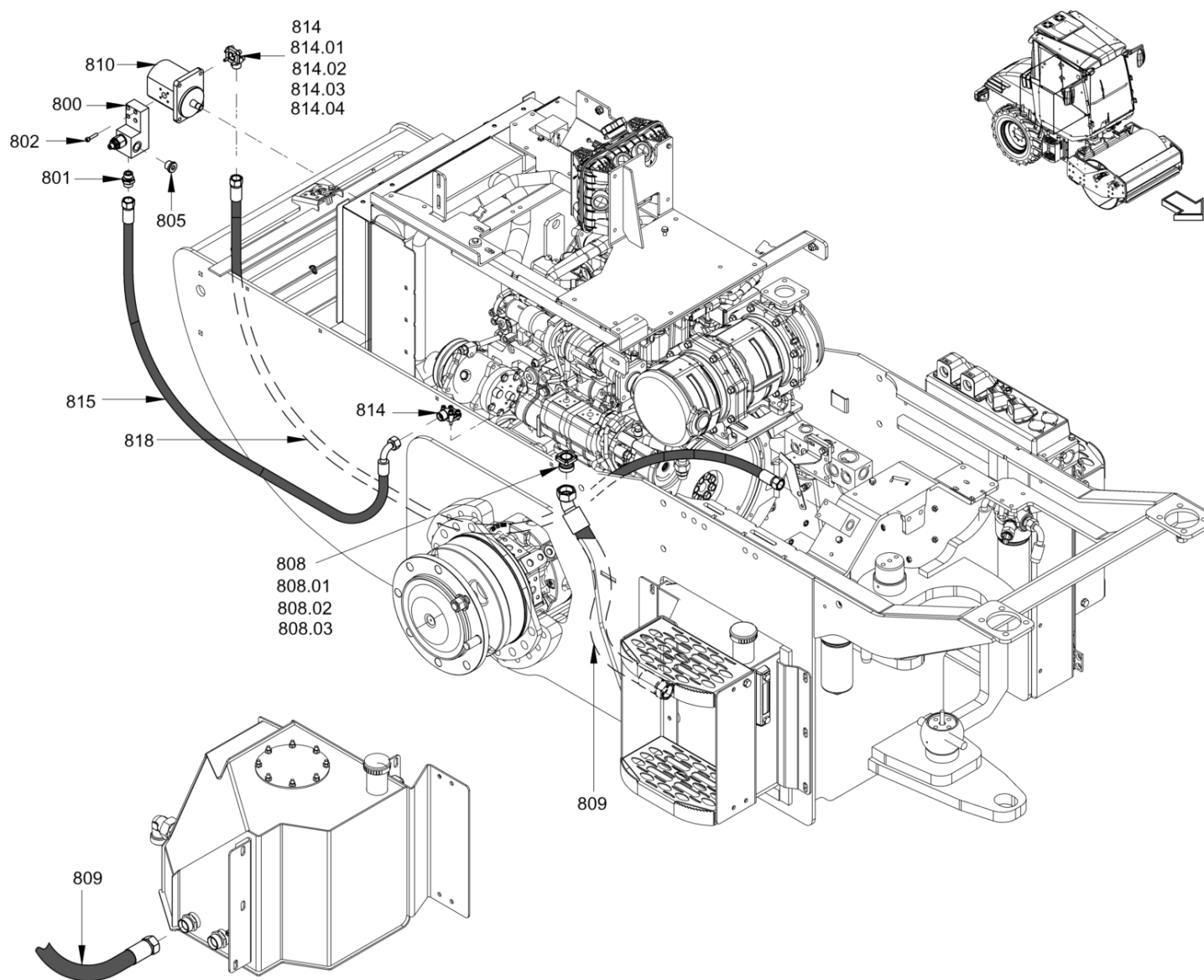

Raffreddamento (motore/olio idraulico)
Refrigeración (motor/aceite hidráulico)
Cooling (engine/hydraulic oil)

Item	Item no.	Descrizione	Descripción	Description	Information	Pc.	Unit
800	5100023524	Valvola limitatrice della pressione	Válvula limitadora de presión	Pressure-relief valve		1	pc
801	5100013603	Presa a vite dritta	Racor para enroscar recto	Straight screwed socket		1	pc
802	5100011481	Vite a testa cilindrica	Tornillo cilíndrico	Cheese-head screw		4	pc
805	5100011665	Tappo a vite	Tornillo de cierre	Screw plug		2	pc
808	5100011500	Anello a o	Anillo toroïdal	O-ring seal	808.01	1	pc
808	5100012723	Vite a testa cilindrica	Tornillo cilíndrico	Cheese-head screw	808.02	4	pc
808	5100012942	Rondella elastica	Arandela elástica	Spring ring	808.03	4	pc
808	5100023115	Connessione a vite flangiata dritta	Racor de brida recto	Straight flange joint		1	pc
809	5100023458	Tubo flessibile	Manguera	Hose		1	pc
810	5100023534	Pompa oleodyn. ad ingranaggi	Motor del engranaje	Gear motor		1	pc
814	5100012216	Connessione a vite con flangia a gomito	Racor de la brida angular	Angle flange screwing		2	pc
814	5100012723	Vite a testa cilindrica	Tornillo cilíndrico	Cheese-head screw	814.02	2	pc
814	5100012942	Rondella elastica	Arandela elástica	Spring ring	814.04	4	pc
814	5100013189	Vite a testa cilindrica	Tornillo cilíndrico	Cheese-head screw	814.03	2	pc
814	5100013612	Anello a o	Anillo toroïdal	O-ring seal	814.01	1	pc
815	5100023547	Tubo flessibile	Manguera	Hose		1	pc
818	5100023457	Tubo flessibile	Manguera	Hose		1	pc



Pompa di regolazione (trazione)
Bomba regulable (acc. trasl.)
Variable displac. pump (drive)

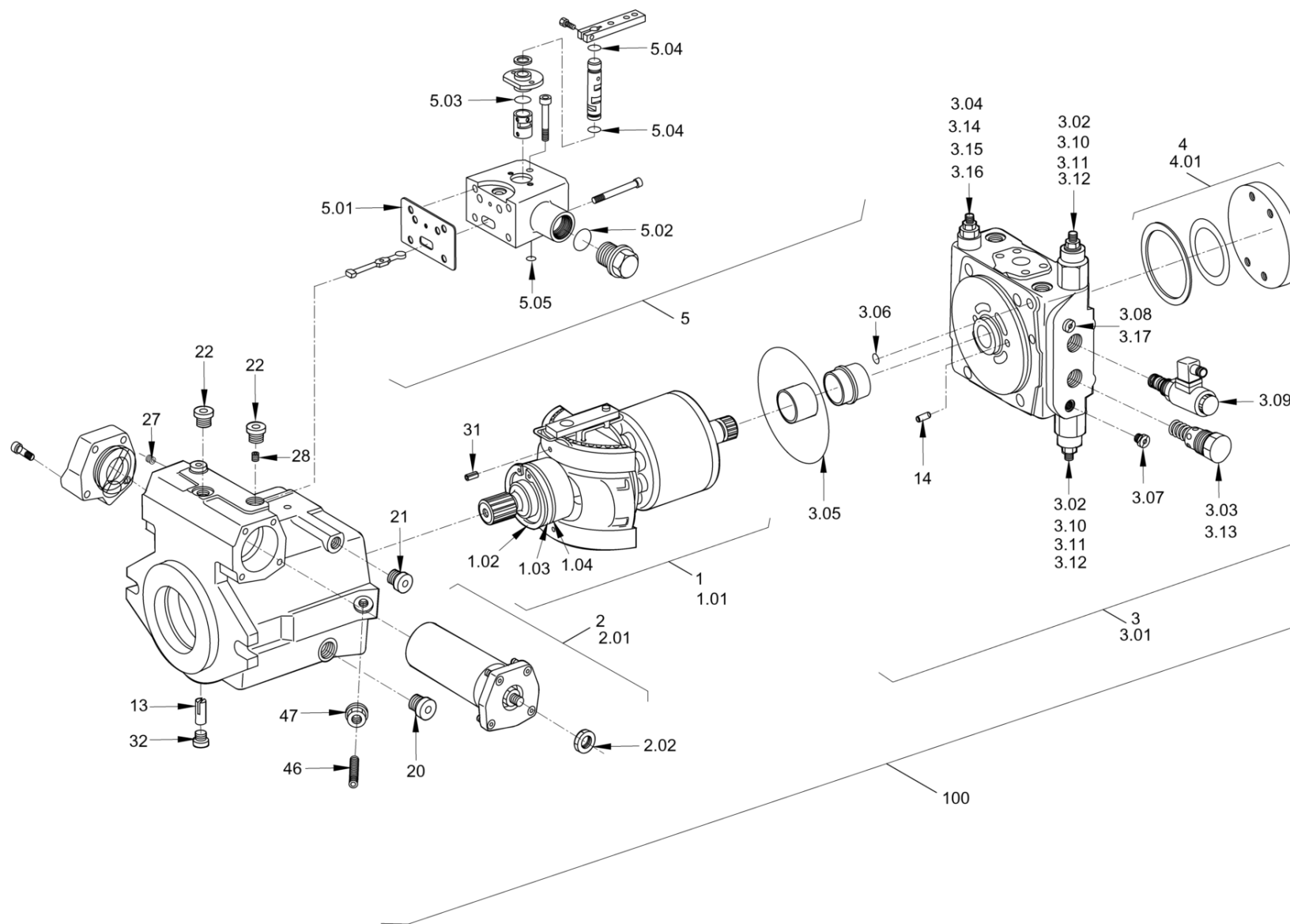

Pompa di regolazione (trazione)
Bomba regulable (acc. trasl.)
Variable displac. pump (drive)

Item	Item no.	Descrizione	Descripción	Description	Information	Pc.	Unit
1	5100023043	Anello di tenuta albero	Junta de eje	Shaft seal	1.03	1	pc
1	5100023052	Anello di sicurezza	Anillo fijador	Circlip	1.02	1	pc
1	5100023146	Kit di tenuta	Kit de juntas	Set of seals	1.01	1	pc
1	5100023205	Anello di sicurezza	Anillo fijador	Circlip	1.04	1	pc
1	5100023248	Meccanismo di azionamento	Mecanismo propulsor	Driving gear		1	pc
2	5100023152	Kit di tenuta	Kit de juntas	Set of seals	2.01	1	pc
2	5100023191	Dado esagonale	Tuerca hexagonal	Hexagonal nut	2.02	1	pc
2	5100023755	Regolazione idraulica	Regulación hidráulica	Hydraulic regulation		1	pc
3	5100070819	Valvola direzionale	Válvula de distribución	Directional control valve	3.09	1	pc
3	5100063978	Valvola limitatrice di pressione	Válvula limitadora de presión	Pressure-relief valve	3.03	1	pc
3	5100023759	Valvola	Válvula	Valve	3.08	1	pc
3	5100023320	Anello a o	Anillo toroïdal	O-ring seal	3.17	1	pc
3	5100023249	Piastra di collegamento	Placa de conexión	Joint plate		1	pc
3	5100023228	Anello a o	Anillo toroïdal	O-ring seal	3.06	1	pc
3	5100023227	Anello a o	Anillo toroïdal	O-ring seal	3.14	1	pc
3	5100023189	Anello di supporto	Anillo de apoyo	Supporting ring	3.12	1	pc
3	5100023153	Kit di tenuta	Kit de juntas	Set of seals	3.01	1	pc
3	5100023044	Valvola limitatrice della pressione	Válvula limitadora de presión	Pressure-relief valve	3.02	2	pc
3	5100023039	Valvola di intercettazione	Válvula de desconexión	Cut-off valve	3.04	1	pc
3	5100013546	Anello a o	Anillo toroïdal	O-ring seal	3.10	1	pc
3	5100013545	Anello a o	Anillo toroïdal	O-ring seal	3.16	1	pc
3	5100013543	Tappo a vite	Tornillo de cierre	Screw plug	3.07	2	pc
3	5100011610	Anello a o	Anillo toroïdal	O-ring seal	3.05	1	pc
3	5100011511	Dado del collare di tenuta	Tuerca c/ collar estanqueidad	Seal nut	3.11	1	pc
3	5100011511	Dado del collare di tenuta	Tuerca c/ collar estanqueidad	Seal nut	3.15	1	pc
3	5100011446	Anello a o	Anillo toroïdal	O-ring seal	3.13	1	pc
4	5100023154	Kit di tenuta	Kit de juntas	Set of seals	4.01	1	pc
4	5100070820	Flangia di connessione	Brida de conexión	Connection flange		1	pc
5	5100023757	Dispositivo di controllo	Aparato de control	Automatic controller		1	pc
5	5100023500	Anello a o	Anillo toroïdal	O-ring seal	5.05	1	pc
5	5100023499	Anello a o	Anillo toroïdal	O-ring seal	5.03	1	pc
5	5100013544	Anello a o	Anillo toroïdal	O-ring seal	5.04	2	pc
5	5100012541	Guarnizione	Junta	Seal	5.01	1	pc
5	5100011448	Anello a o	Anillo toroïdal	O-ring seal	5.02	1	pc
13	5100023204	Perno	Rspiga	Pin		1	pc
14	5100022944	Perno di fissaggio	Pasador fijador	Positioning pin		1	pc

Pompa di regolazione (trazione)
Bomba regulable (acc. trasl.)
Variable displac. pump (drive)

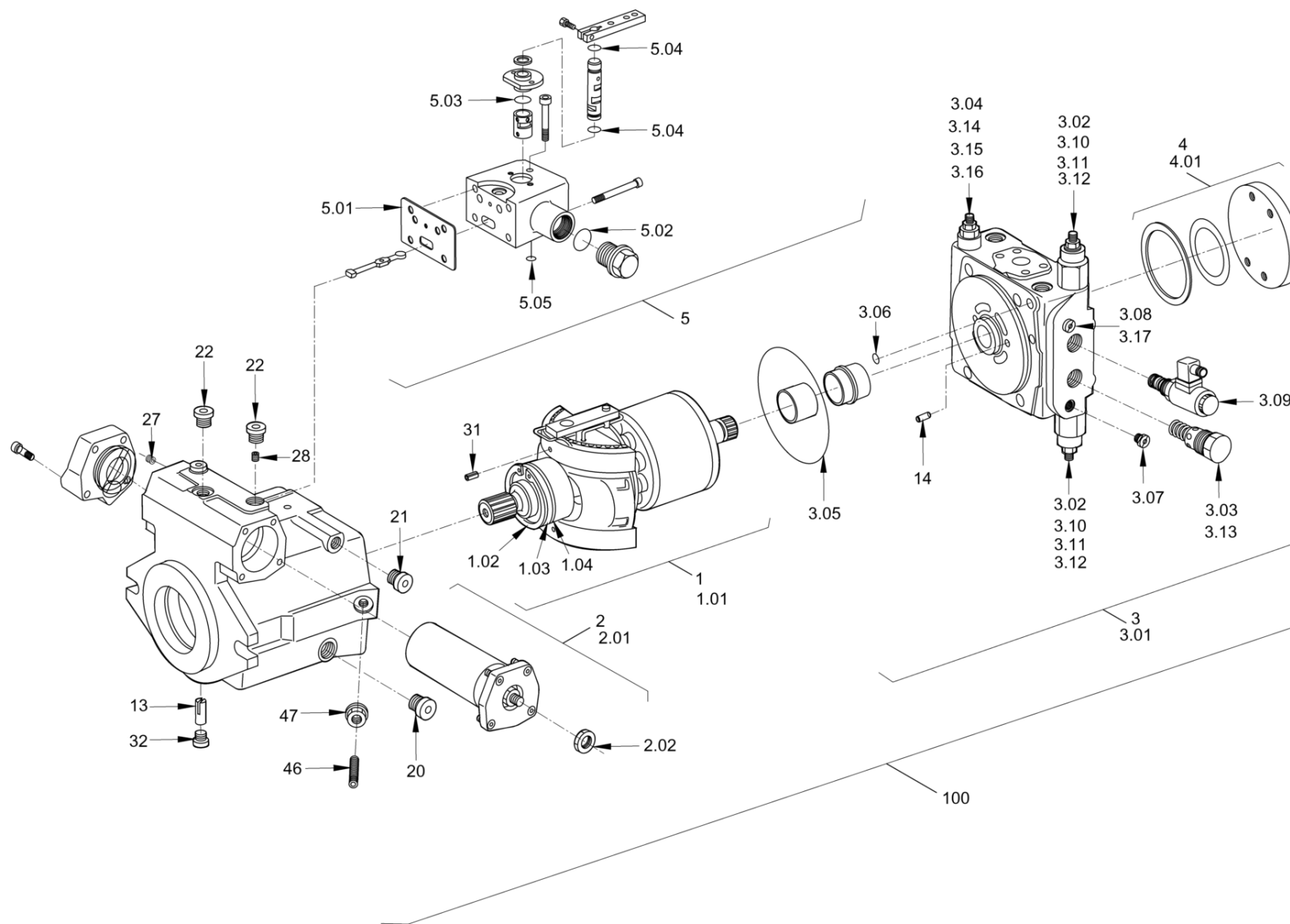

Pompa di regolazione (trazione)
Bomba regulable (acc. trasl.)
Variable displac. pump (drive)

Item	Item no.	Descrizione	Descripción	Description	Information	Pc.	Unit
20	5100011452	Tappo a vite	Tornillo de cierre	Screw plug		1	pc
21	5100011453	Tappo a vite	Tornillo de cierre	Screw plug		2	pc
22	5100013543	Tappo a vite	Tornillo de cierre	Screw plug		6	pc
27	5100022998	Tamponamento	Prueba	Bung		2	pc
28	5100022922	Ugello	Tobera	Nozzle		2	pc
31	5100070821	Spina	Espiga	Pin		2	pc
32	5100011454	Tappo a vite	Tornillo de cierre	Screw plug		1	pc
46	5100023758	Vite senza testa	Espiga roscada	Threaded pin		1	pc
47	5100022999	Dado del collare di tenuta	Tuerca c/ collar estanqueidad	Seal nut		1	pc
100	5100070794	Pompa vibrante	Bomba de vibración	Vibration pump		1	pc



Pompa di regolazione (vibratore)
 Bomba regulable (vibración)
 Variable displac. pump (vibr.)

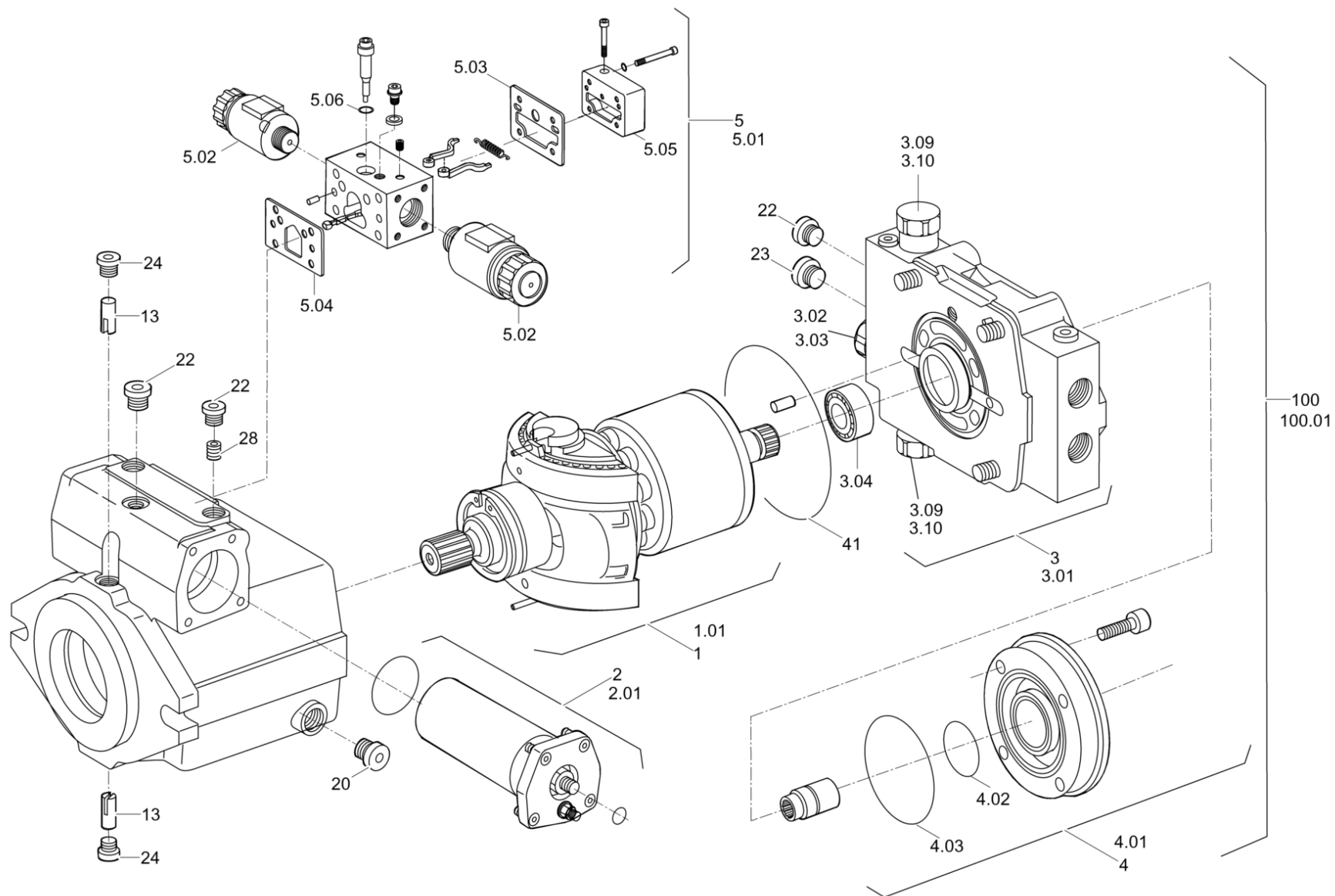

Pompa di regolazione (vibratore)
Bomba regulable (vibración)
Variable displac. pump (vibr.)

Item	Item no.	Descrizione	Descripción	Description	Information	Pc.	Unit
1	5100011957	Kit di tenuta	Kit de juntas	Set of seals	1.01	1	pc
1	5100070822	Impianto motopropulsore	Mecanismo propulsor	Driving gear		1	pc
2	5100011958	Kit di tenuta	Kit de juntas	Set of seals	2.01	1	pc
2	5100070823	Regolazione idraulica	Regulación hidráulica	Hydraulic regulation		1	pc
3	5100011626	Valvola limitatrice della pressione	Válvula limitadora de presión	Pressure-relief valve	3.10	2	pc
3	5100011627	Anello a o	Anillo toroïdal	O-ring seal	3.09	1	pc
3	5100011959	Kit di tenuta	Kit de juntas	Set of seals	3.01	1	pc
3	5100013546	Anello a o	Anillo toroïdal	O-ring seal	3.03	1	pc
3	5100070728	Vite di chiusura	Tornillo de cierre	Locking screw	3.02	1	pc
3	5100070824	Cuscinetto a rulli cilindrico	Rodamiento de rodillos cilínd.	Cylindrical roller bearing	3.04	1	pc
3	5100070825	Piastra di collegamento	Placa de conexión	Joint plate		1	pc
4	5100011440	Anello a o	Anillo toroïdal	O-ring seal	4.03	1	pc
4	5100013548	Anello a o	Anillo toroïdal	O-ring seal	4.02	1	pc
4	5100023050	Flangia di giunzione	Brida de conexión	Connection flange		1	pc
4	5100023130	Kit di tenuta	Kit de juntas	Set of seals	4.01	1	pc
5	5100070681	Coperchio con filtro	Tapa con filtro	Cover with filter	5.05	1	pc
5	5100035097	Anello a o	Anillo toroïdal	O-ring seal	5.06	1	pc
5	5100023729	Dispositivo di controllo	Aparato de control	Automatic controller		1	pc
5	5100023192	Guarnizione	Junta	Sealing	5.03	1	pc
5	5100023186	Magnete	Imán	Magnet	5.02	2	pc
5	5100023131	Kit di tenuta	Kit de juntas	Set of seals	5.01	1	pc
5	5100012541	Guarnizione	Junta	Seal	5.04	1	pc
13	5100023206	Perno	Espiga	Pin		2	pc
20	5100011743	Tappo a vite	Tornillo de cierre	Screw plug		1	pc
22	5100013543	Tappo a vite	Tornillo de cierre	Screw plug		4	pc
23	5100011453	Tappo a vite	Tornillo de cierre	Screw plug		1	pc
24	5100011454	Tappo a vite	Tornillo de cierre	Screw plug		2	pc
28	5100023024	Ugello	Tobera	Nozzle		2	pc
41	5100013601	Anello a o	Anillo toroïdal	O-ring seal		1	pc
100	5100023129	Kit di tenuta	Kit de juntas	Set of seals	100.01	1	pc
100	5100070789	Pompa di regolazione	Bomba regulable	Variable displacement pump		1	pc

Constant motor (vibration driv
Motor constante (accionamiento
Constant motor (vibration driv

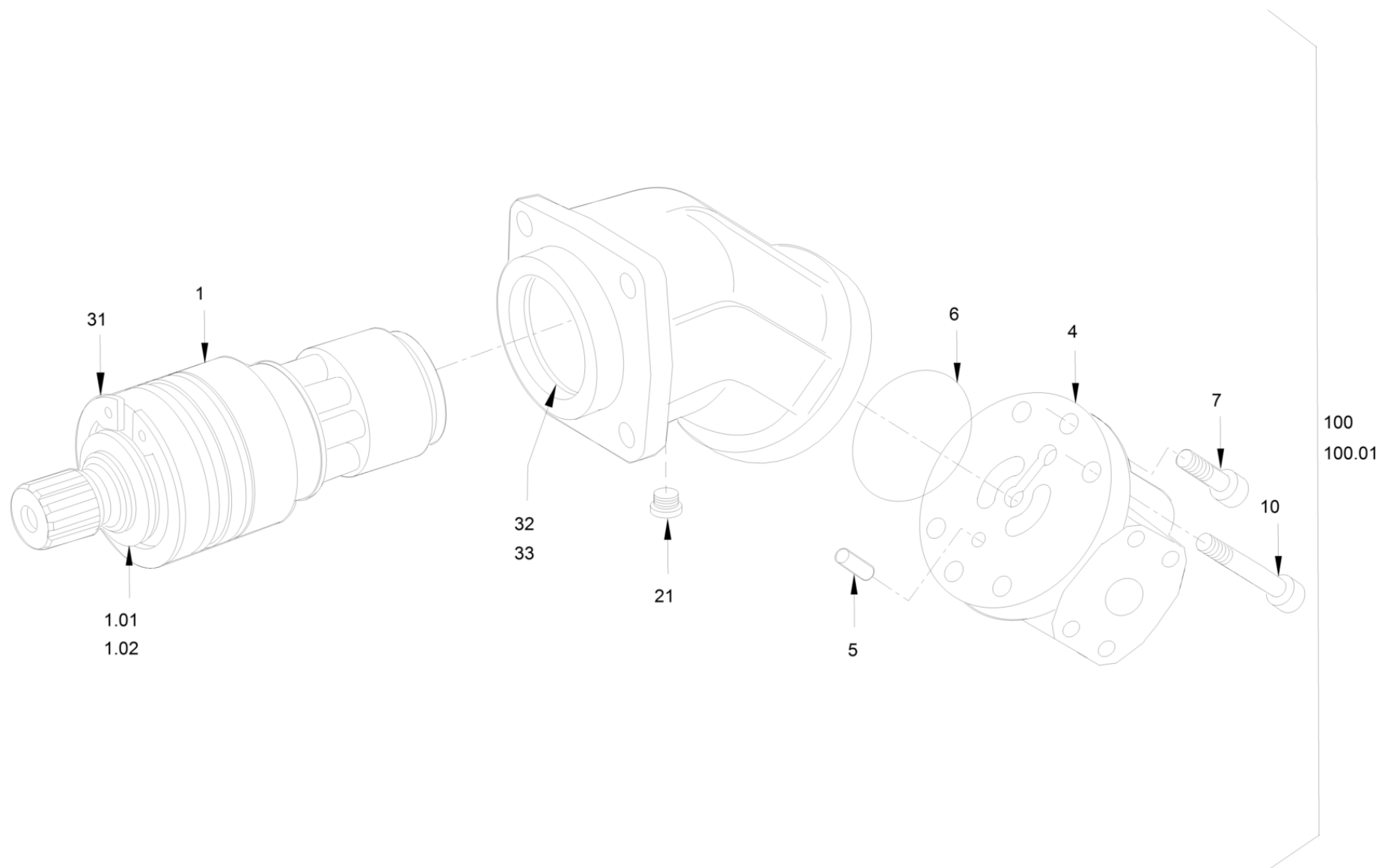

Constant motor (vibration driv
Motor constante (accionamiento
Constant motor (vibration driv

Item	Item no.	Descrizione	Descripción	Description	Information	Pc.	Unit
1	5100022858	Anello di sicurezza	Anillo fijador	Circlip	1.02	1	pc
1	5100023032	Meccanismo di azionamento	Mecanismo propulsor	Driving gear		1	pc
1	5100023722	Disco di supporto	Disco de apoyo	Support disc	1.01	1	pc
4	5100023031	Piastra di collegamento	Placa de conexión	Joint plate		1	pc
5	5100022993	Perno cilindrico	Espiga cilíndrica	Straight pin		1	pc
6	5100023033	Anello a o	Anillo toroïdal	O-ring seal		1	pc
7	5100011443	Vite a testa cilindrica	Tornillo cilíndrico	Cheese-head screw		2	pc
10	5100013189	Vite a testa cilindrica	Tornillo cilíndrico	Cheese-head screw		4	pc
21	5100023261	Vite di bloccaggio	Tornillo de cierre	Locking screw		1	pc
31	5100022861	Anello di sicurezza	Anillo fijador	Circlip		1	pc
32	5100023034	Anello a o	Anillo toroïdal	O-ring seal		1	pc
33	5100023035	Anello di tenuta albero	Junta de eje	Shaft seal		1	pc
100	5100023397	Motore costante	Motor de volumen constante	Constant motor		1	pc
100	5100046833	Segnalatore acustico	Bocina	Signal horn	100.01	1	pc



Unità di distribuzione
Unidad del distribuidor
Distributor unit

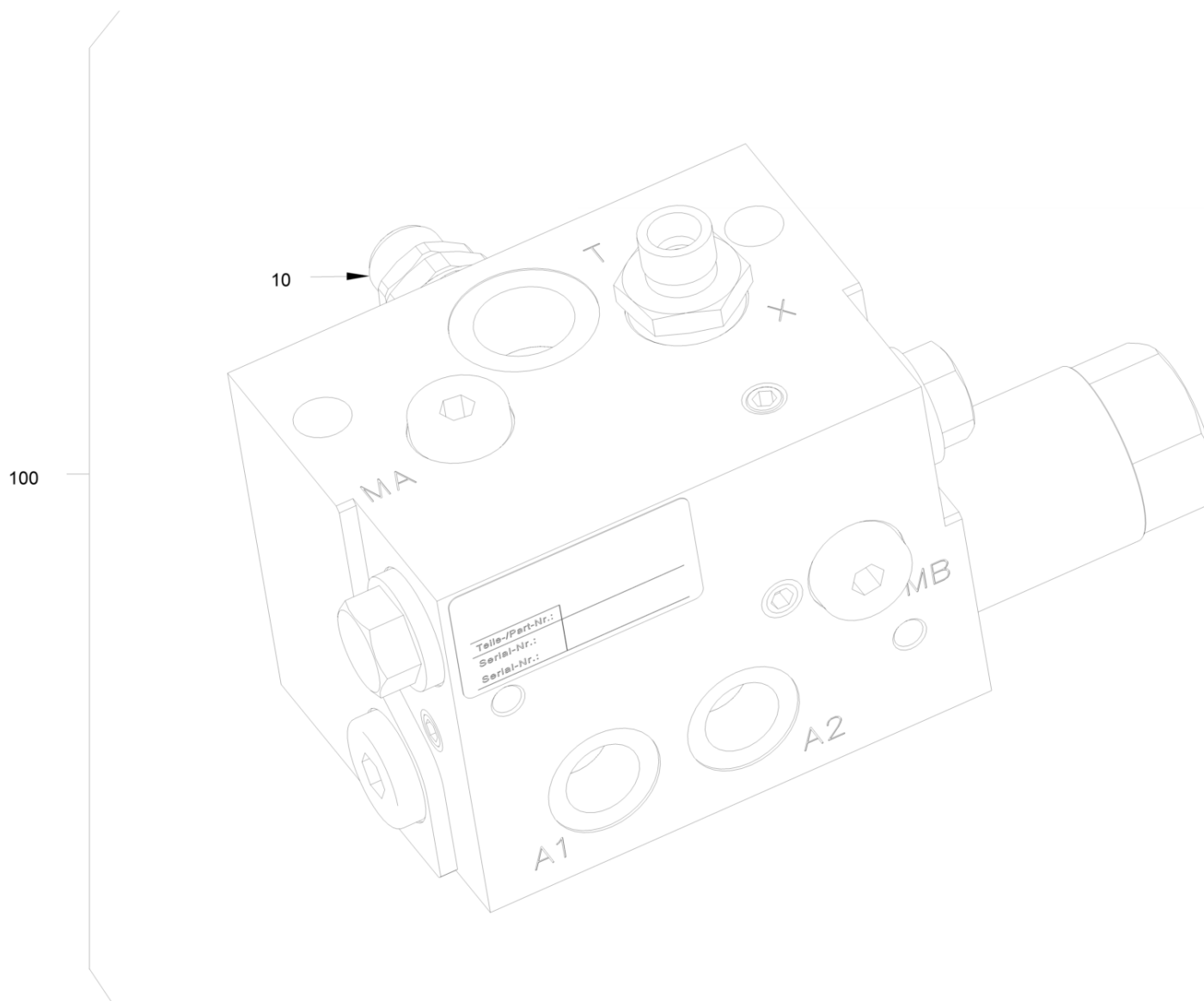

Unità di distribuzione
Unidad del distribuidor
Distributor unit

Item	Item no.	Descrizione	Descripción	Description	Information	Pc.	Unit
10	5100048722	Valvola limitatrice della pressione	Válvula limitadora de presión	Pressure-relief valve		1	pc
100	5100048694	Valvola di scarico	Válvula de enjuague	Flush valve		1	pc



Motore sui mozzi delle ruote
Motor del cubo de la rueda
Gear hub motor

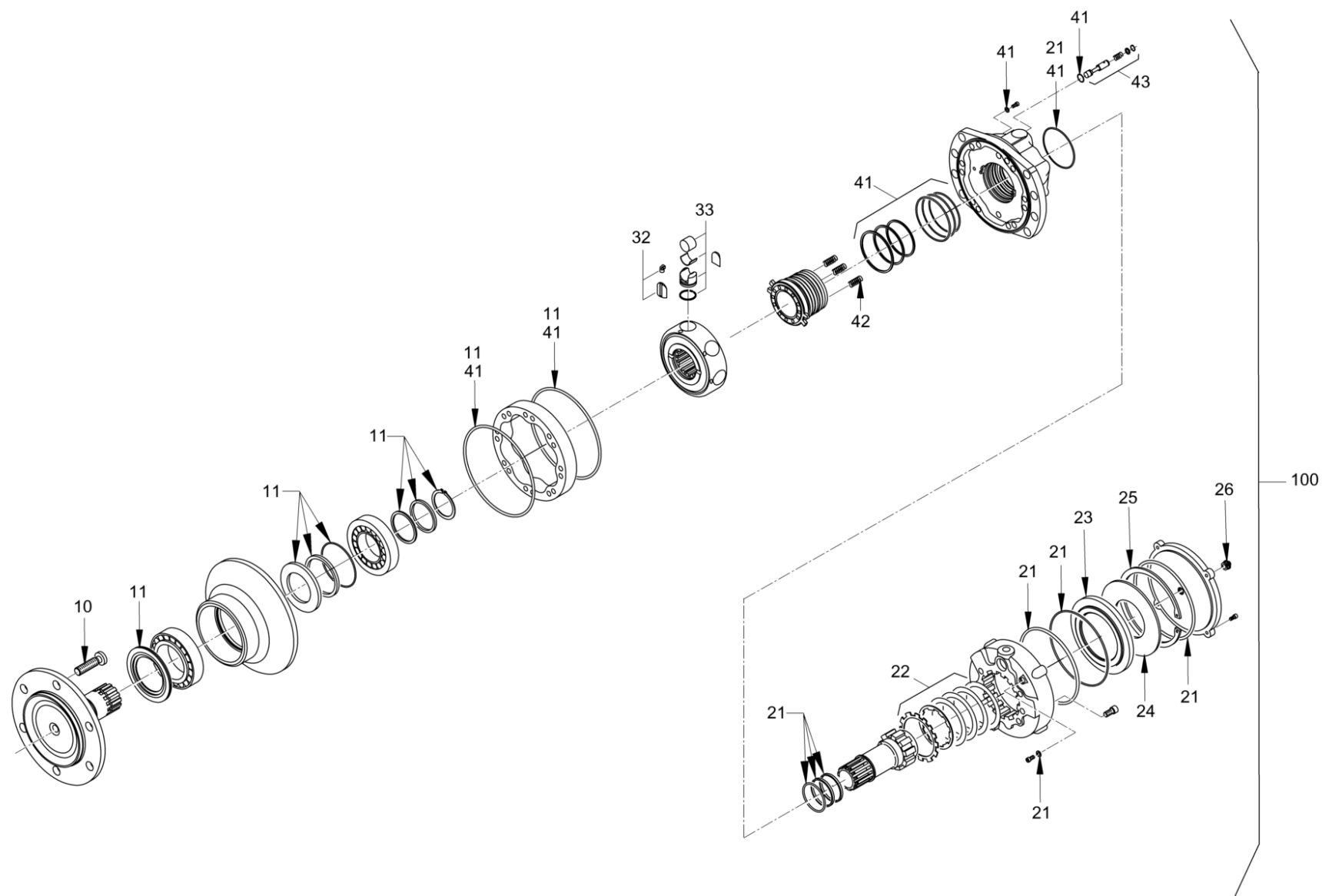

Motore sui mozzi delle ruote
Motor del cubo de la rueda
Gear hub motor

Item	Item no.	Descrizione	Descripción	Description	Information	Pc.	Unit
10	5100023768	Kit di riparazione	Kit de reparación	Repair set		1	pc
11	5100023767	Kit di riparazione	Kit de reparación	Repair set		1	pc
21	5100023769	Kit di riparazione	Kit de reparación	Repair set		1	pc
22	5100023167	Kit dischi freno	Juego de discos de freno	Brake disc set		1	pc
23	5100023327	Pistone del freno	Pistón del freno	Brake piston		1	pc
24	5100022919	Rondella elastica	Muelle de disco	Cup spring		1	pc
25	5100022917	Anello di sicurezza	Anillo fijador	Circlip		1	pc
26	5100070689	Tappo a vite	Tapón	Bung		1	pc
32	5100023139	Kit di riparazione	Kit de reparación	Repair set		1	pc
33	5100023766	Kit di riparazione	Kit de reparación	Repair set		8	pc
41	5100023245	Kit di tenuta	Kit de juntas	Set of seals		1	pc
42	5100023199	Kit di riparazione	Kit de reparación	Repair set		1	pc
43	5100023244	Kit di tenuta	Kit de juntas	Set of seals		1	pc
100	5100070690	Motore sui mozzi delle ruote	Motor del cubo de la rueda	Gear hub motor		1	pc



Motore sui mozzi delle ruote
Motor del cubo de la rueda
Gear hub motor

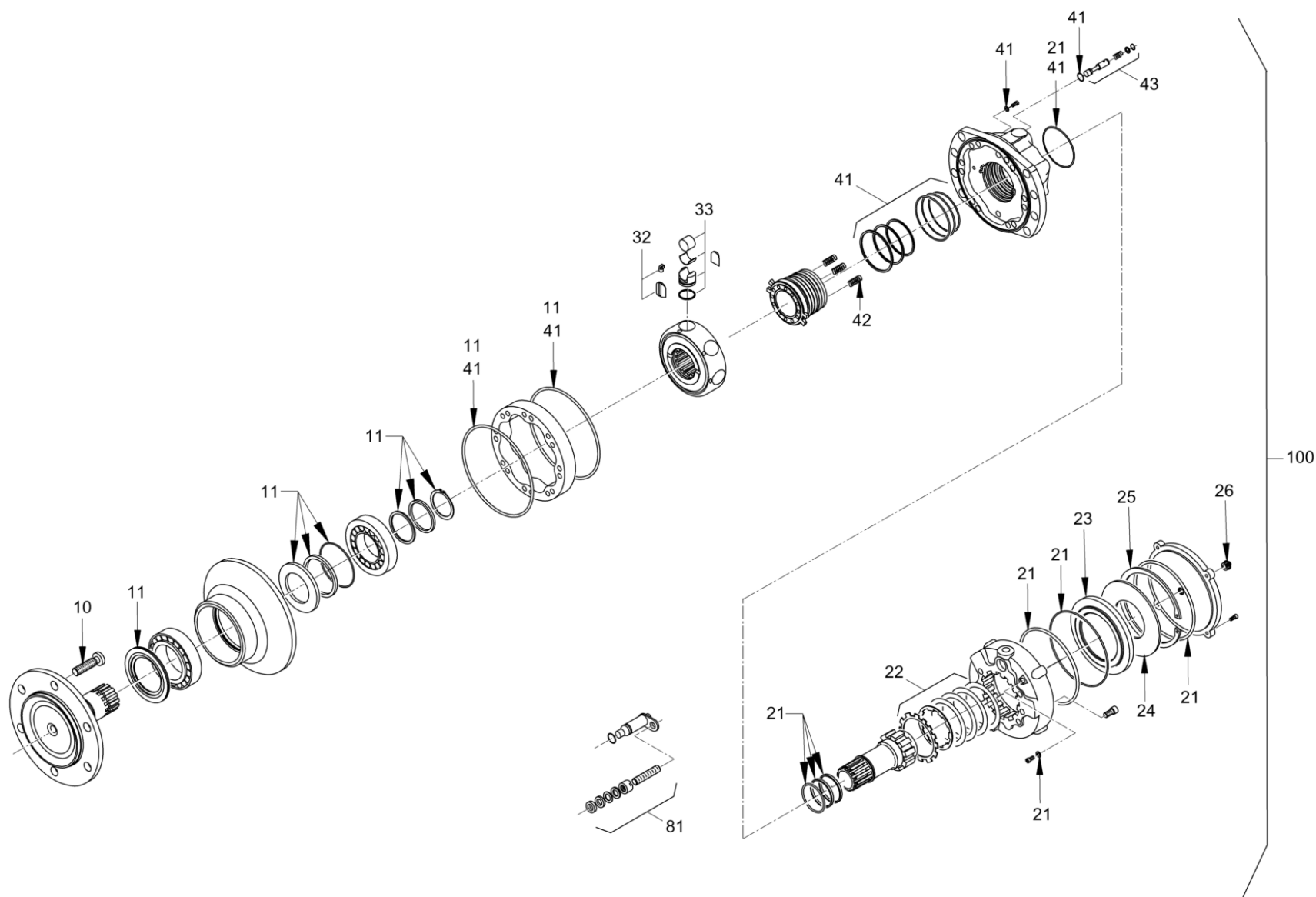

Motore sui mozzi delle ruote
Motor del cubo de la rueda
Gear hub motor

Item	Item no.	Descrizione	Descripción	Description	Information	Pc.	Unit
10	5100023768	Kit di riparazione	Kit de reparación	Repair set		1	pc
11	5100023767	Kit di riparazione	Kit de reparación	Repair set		1	pc
21	5100023769	Kit di riparazione	Kit de reparación	Repair set		1	pc
22	5100023167	Kit dischi freno	Juego de discos de freno	Brake disc set		1	pc
23	5100023327	Pistone del freno	Pistón del freno	Brake piston		1	pc
24	5100022919	Rondella elastica	Muelle de disco	Cup spring		1	pc
25	5100022917	Anello di sicurezza	Anillo fijador	Circlip		1	pc
26	5100070689	Tappo a vite	Tapón	Bung		1	pc
32	5100023139	Kit di riparazione	Kit de reparación	Repair set		1	pc
33	5100023766	Kit di riparazione	Kit de reparación	Repair set		8	pc
41	5100023245	Kit di tenuta	Kit de juntas	Set of seals		1	pc
42	5100023199	Kit di riparazione	Kit de reparación	Repair set		1	pc
43	5100023244	Kit di tenuta	Kit de juntas	Set of seals		1	pc
81	5100023243	Set di fissaggio	Juego de fijación	Fastening set		1	pc
100	5100070691	Motore sui mozzi delle ruote	Motor del cubo de la rueda	Gear hub motor		1	pc

Motore sui mozzi delle ruote
Motor del cubo de la rueda
Gear hub motor

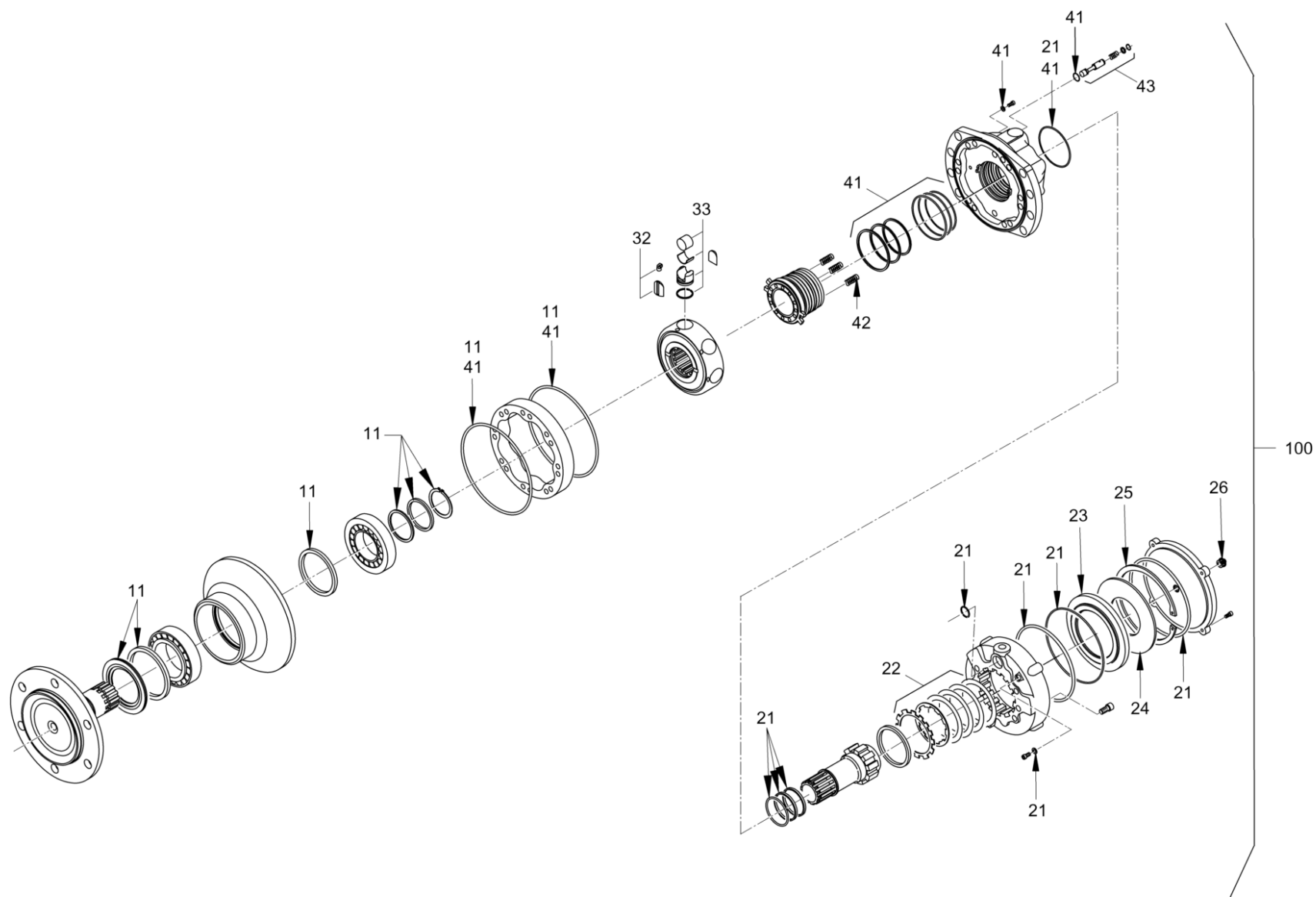

Motore sui mozzi delle ruote
Motor del cubo de la rueda
Gear hub motor

Item	Item no.	Descrizione	Descripción	Description	Information	Pc.	Unit
11	5100023762	Kit di riparazione	Kit de reparación	Repair set		1	pc
21	5100023761	Kit di riparazione	Kit de reparación	Repair set		1	pc
22	5100023167	Kit dischi freno	Juego de discos de freno	Brake disc set		1	pc
23	5100023327	Pistone del freno	Pistón del freno	Brake piston		1	pc
24	5100022919	Rondella elastica	Muelle de disco	Cup spring		1	pc
25	5100022917	Anello di sicurezza	Anillo fijador	Circlip		1	pc
26	5100070689	Tappo a vite	Tapón	Bung		1	pc
32	5100023011	Kit di riparazione	Kit de reparación	Repair set		1	pc
33	5100023766	Kit di riparazione	Kit de reparación	Repair set		10	pc
41	5100023764	Kit di riparazione	Kit de reparación	Repair set		1	pc
42	5100023199	Kit di riparazione	Kit de reparación	Repair set		1	pc
43	5100070696	Kit riparazione	Kit de reparación	Repair set		1	pc
100	5100070698	Motore sui mozzi delle ruote	Motor del cubo de la rueda	Gear hub motor		1	pc



Blocco valvole (freno di stazionamento)
Bloque de válvula (freno estac)
Valve block (parking brake)

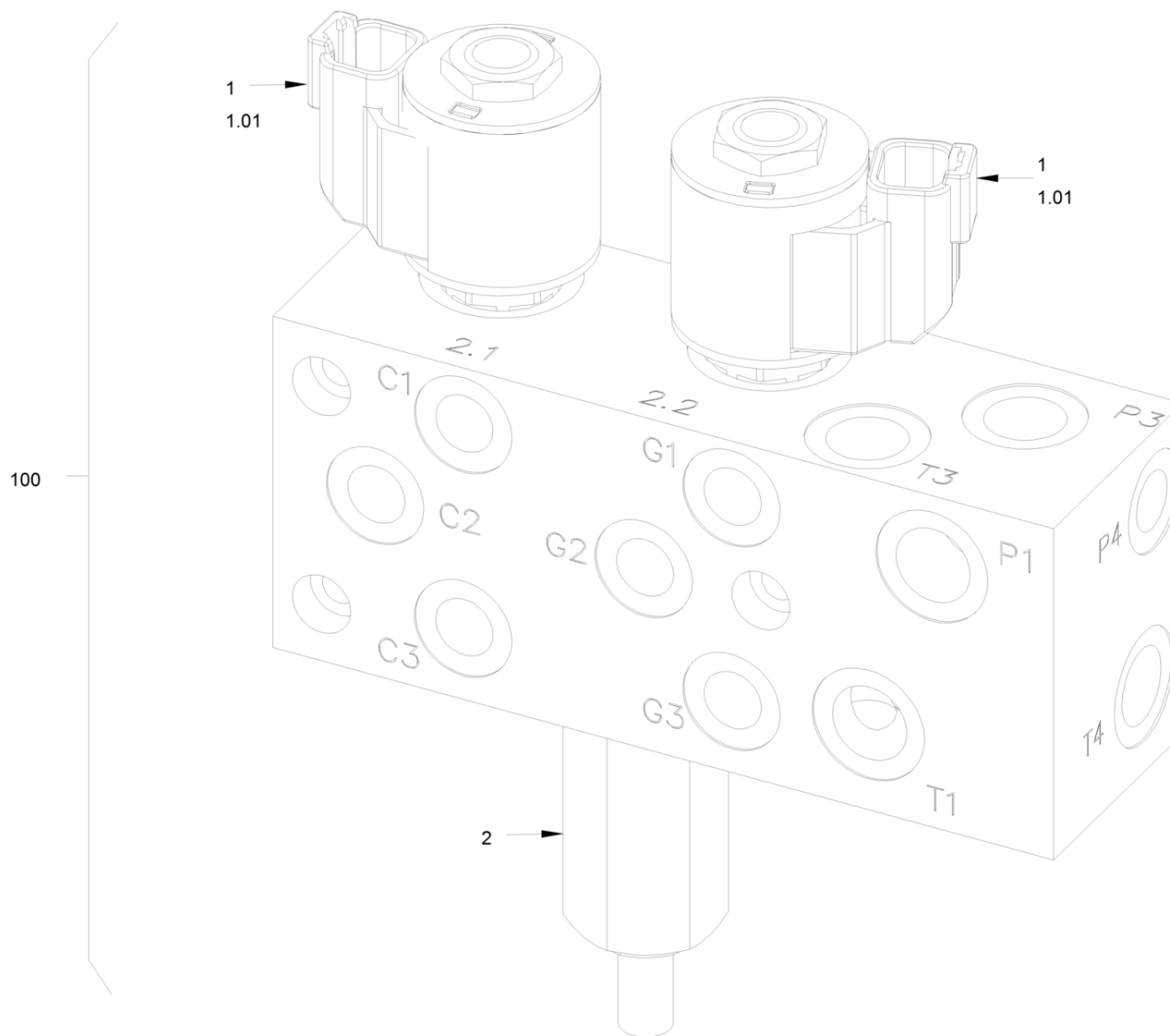

Blocco valvole (freno di stazionamento)
Bloque de válvula (freno estac)
Valve block (parking brake)

Item	Item no.	Descrizione	Descripción	Description	Information	Pc.	Unit
1	5100023234	Valvola di controllo direzionale	Válvula de distribución	Directional control valve		2	pc
1	5100023258	Solenoide	Bobina magnética	Solenoid coil	1.01	2	pc
2	5100023661	Valvola limitatrice della pressione	Válvula limitadora de presión	Pressure-relief valve		1	pc
100	5100023341	Blocco valvole	Bloque de válvula	Valve block		1	pc



Motore a ingranaggi
Motor del engranaje
Gear motor

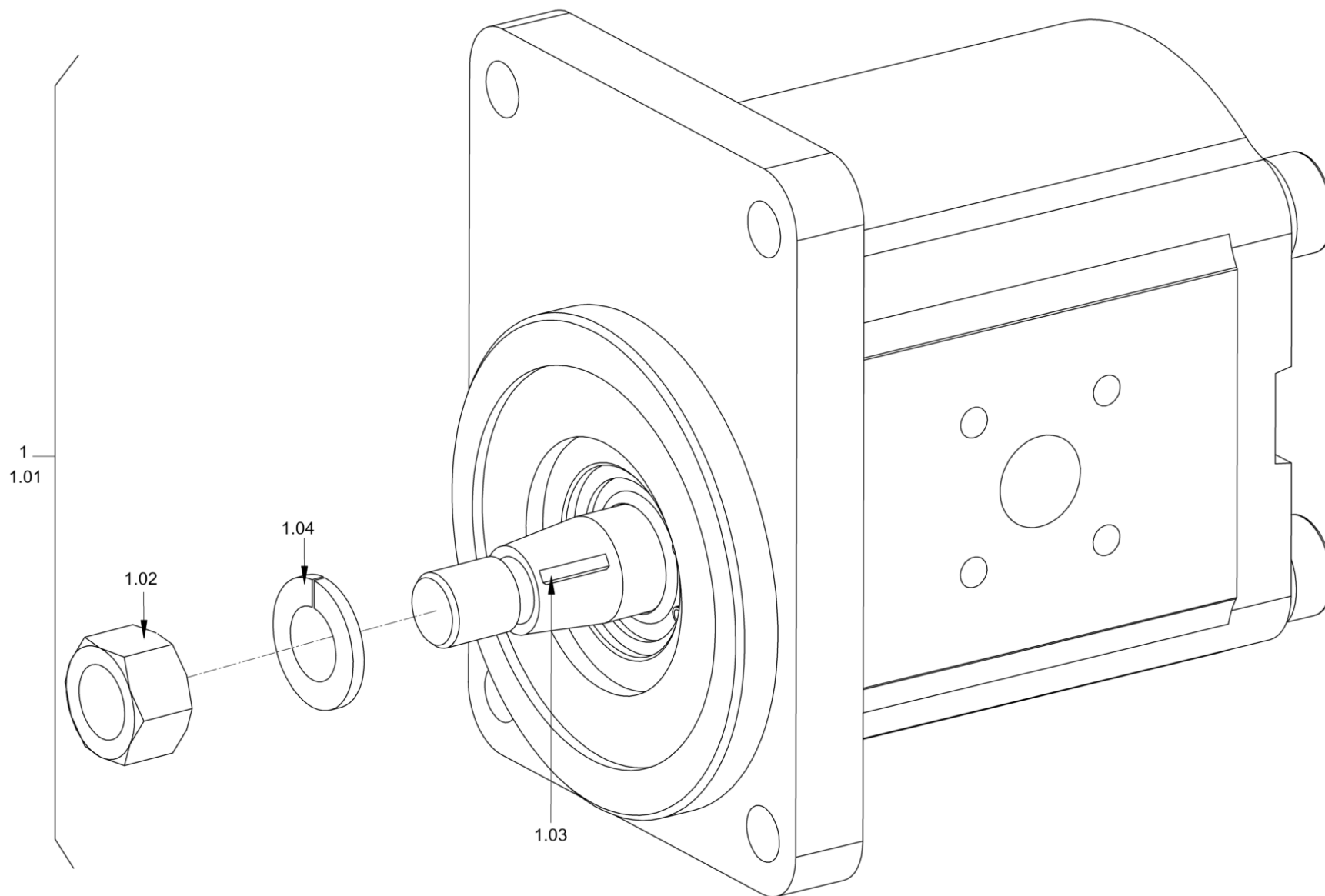

Motore a ingranaggi
Motor del engranaje
Gear motor

Item	Item no.	Descrizione	Descripción	Description	Information	Pc.	Unit
1	5100012944	Rondella elastica	Arandela elástica	Spring ring	1.04	1	pc
1	5100013445	Dado esagonale	Tuerca hexagonal	Hexagon nut	1.02	1	pc
1	5100013446	Chiavetta woodruff	Chaveta de disco	Disk spring	1.03	1	pc
1	5100023534	Pompa oleodyn. ad ingranaggi	Motor del engranaje	Gear motor		1	pc
1	5100065348	Kit di tenuta	Kit de juntas	Set of seals	1.01	1	pc



Pompa tandem
Bomba tándem
Tandem pump

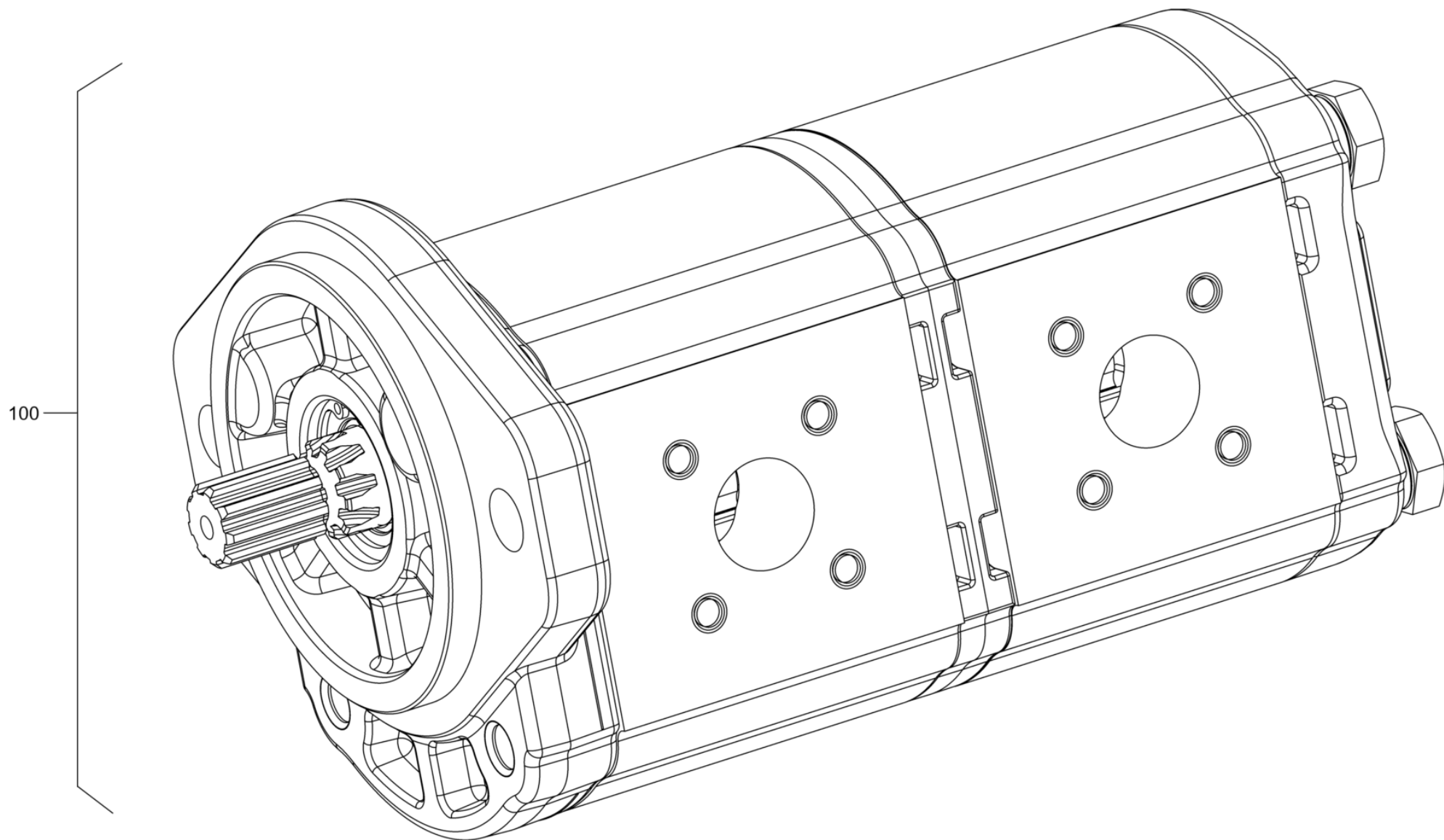

Pompa tandem
Bomba tándem
Tandem pump

Item	Item no.	Descrizione	Descripción	Description	Information	Pc.	Unit
100	5100023305	Pompa tandem	Bomba tándem	Tandem pump		1	pc



Serbatoio olio idraulico
Tanque de aceite hidráulico
Hydraulic oil tank

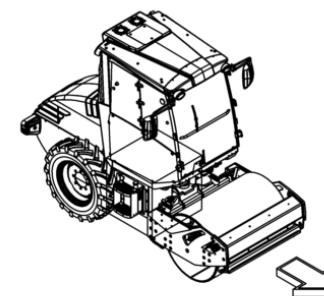
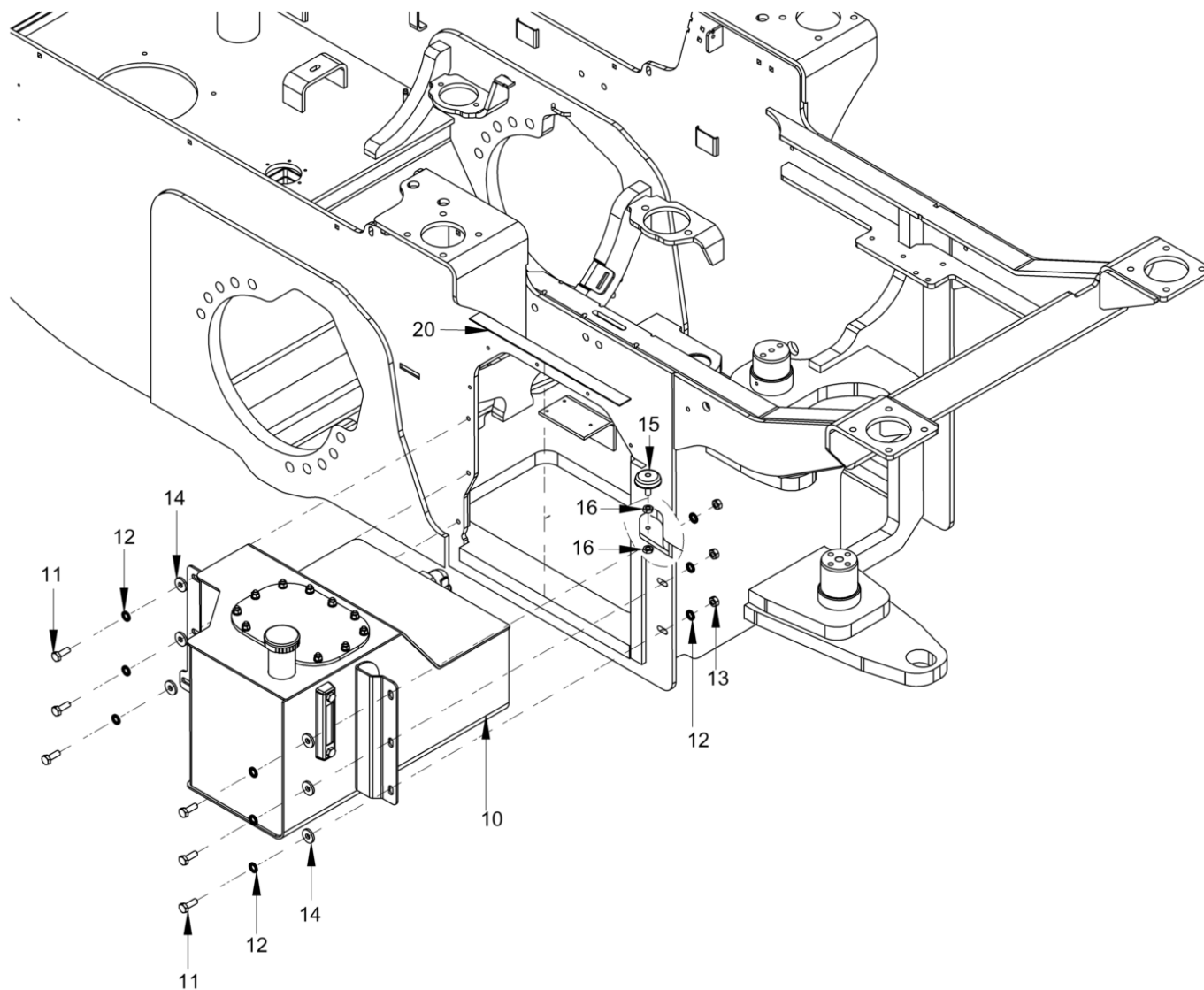

Serbatoio olio idraulico
Tanque de aceite hidráulico
Hydraulic oil tank

Item	Item no.	Descrizione	Descripción	Description	Information	Pc.	Unit
10	5100070700	Serbatoio olio idraulico	Tanque de aceite hidráulico	Hydraulic oil tank		1	pc
11	5100013416	Bullone esagonale	Tornillo hexagonal	Hexagon screw		6	pc
12	5100012967	Rondella di sicurezza	Disco de seguridad	Locking washer		9	pc
13	5100012547	Dado esagonale	Tuerca hexagonal	Hexagon nut		3	pc
14	5100013128	Rondella	Arandela	Washer		6	pc
15	5100013377	Buffer di arresto	Tampón de tope	Rubber buffer		1	pc
16	5100011533	Dado esagonale	Tuerca hexagonal	Hexagon nut		2	pc
20	5100023662	Fasce di gomma	Cinta de goma	Rubber tape		0.6	m



Serbatoio olio idraulico
Tanque de aceite hidráulico
Hydraulic oil tank

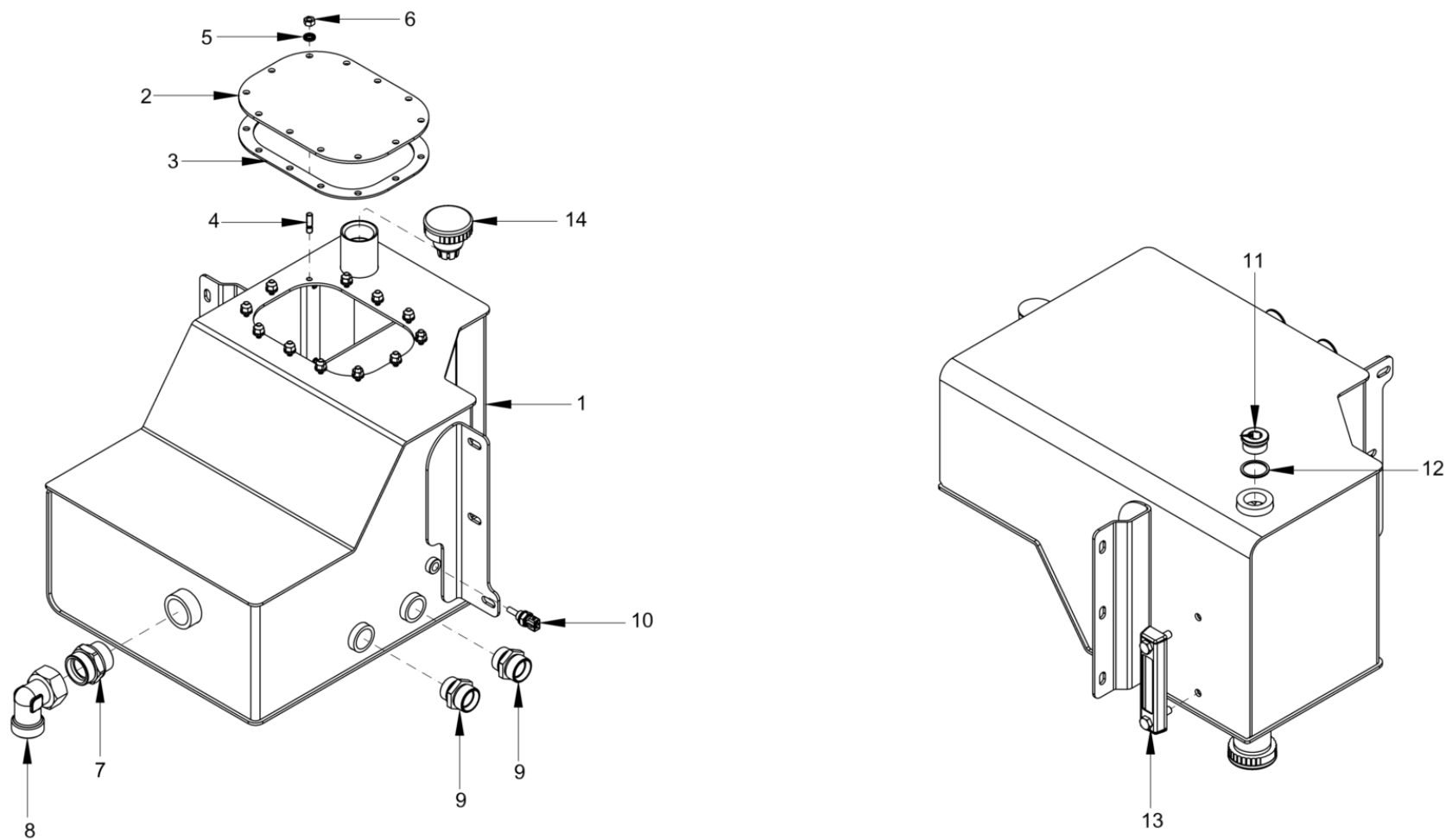

100

Serbatoio olio idraulico
Tanque de aceite hidráulico
Hydraulic oil tank

Item	Item no.	Descrizione	Descripción	Description	Information	Pc.	Unit
1	5100070701	Serbatoio olio idraulico	Tanque de aceite hidráulico	Hydraulic oil tank		1	pc
2	5100070702	Coperchio	Tapa	Lid		1	pc
3	5100070704	Guarnizione	Junta	Sealing		1	pc
4	5100011471	Prigioniero	Espárrago	Stud bolt		12	pc
5	5100012966	Rondella di sicurezza	Disco de seguridad	Locking washer		12	pc
6	5100012546	Dado esagonale	Tuerca hexagonal	Hexagon nut		12	pc
7	5100023155	Presa a vite dritta	Racor para enroscar recto	Straight screwed socket		1	pc
8	5100022892	Connettore a gomito regolabile	Racor angular ajustable	Elbow adjustable		1	pc
9	5100022887	Presa a vite dritta	Racor para enroscar recto	Straight screwed socket		2	pc
10	5100023402	Sensore di temperatura	Interruptor de temperatura	Temperature switch		1	pc
11	5100023027	Vite di bloccaggio	Tornillo de cierre	Locking screw		1	pc
12	5100022869	Guarnizione	Anillo de junta	Sealing ring		1	pc
13	5100013435	Indicatore del livello dell'olio	Indicador de nivel de aceite	Oil level indicator		1	pc
14	5100039052	Filtro di ventilazione	Filtro de ventilación	Vent filter		1	pc
100	5100070700	Serbatoio olio idraulico	Tanque de aceite hidráulico	Hydraulic oil tank		1	pc



Serbatoio olio idraulico
Tanque de aceite hidráulico
Hydraulic oil tank

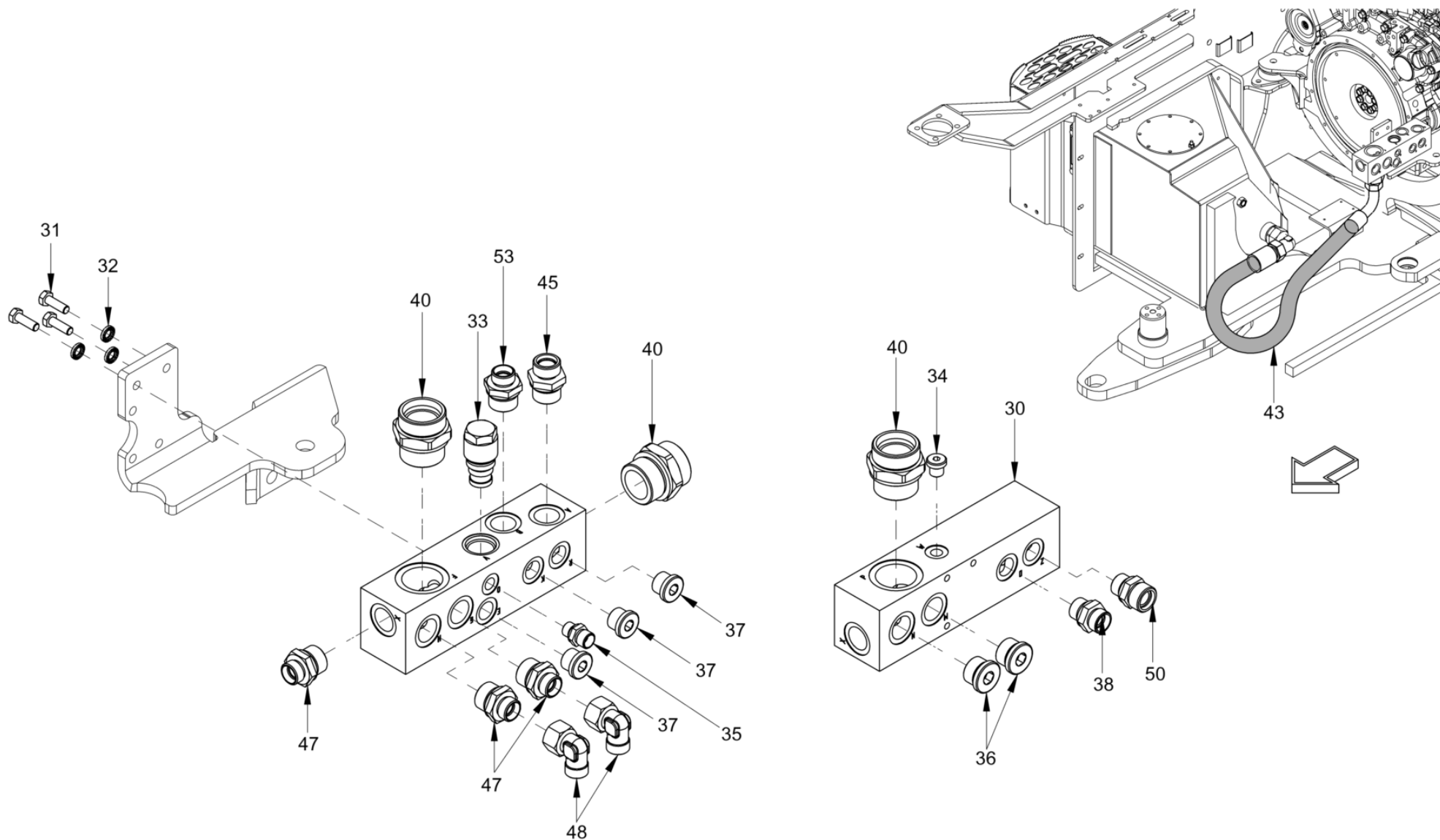

Serbatoio olio idraulico
Tanque de aceite hidráulico
Hydraulic oil tank

Item	Item no.	Descrizione	Descripción	Description	Information	Pc.	Unit
30	5100023235	Perno di raccordo	Bloque de conexión	Connecting block		1	pc
31	5100012613	Bullone esagonale	Tornillo hexagonal	Hexagon screw		3	pc
32	5100012966	Rondella di sicurezza	Disco de seguridad	Locking washer		3	pc
33	5100023226	Valvola di controllo direzionale	Válvula de distribución	Directional control valve		1	pc
34	5100011608	Tappo a vite	Tornillo de cierre	Screw plug		1	pc
35	5100013492	Pres a vite diritta	Racor para enroscar recto	Straight screwed socket		1	pc
36	5100023025	Vite di bloccaggio	Tornillo de cierre	Locking screw		2	pc
37	5100011665	Tappo a vite	Tornillo de cierre	Screw plug		3	pc
38	5100013476	Pres a vite diritta	Racor para enroscar recto	Straight screwed socket		1	pc
40	5100023155	Pres a vite diritta	Racor para enroscar recto	Straight screwed socket		3	pc
43	5100023319	Tubo flessibile	Manguera	Hose		1	pc
45	5100013615	Pres a vite diritta	Racor para enroscar recto	Straight screwed socket		1	pc
47	5100013614	Pres a vite diritta	Racor para enroscar recto	Straight screwed socket		3	pc
48	5100013483	Connettore a gomito regolabile	Racor angular ajustable	Elbow adjustable		2	pc
50	5100013476	Pres a vite diritta	Racor para enroscar recto	Straight screwed socket		1	pc
50	5100013499	Pres a vite diritta	Racor para enroscar recto	Straight screwed socket		1	pc
53	5100013614	Pres a vite diritta	Racor para enroscar recto	Straight screwed socket		1	pc



Tavola apparecchiature
 Panel de instrumentos
 Instrument panel



Tavola apparecchiature
Panel de instrumentos
Instrument panel

Item	Item no.	Descrizione	Descripción	Description	Information	Pc.	Unit
20	5100011595	Telaio	Bastidor	Frame		2	pc
21	5100011597	Pulsante	Pulsador	Push-button		1	pc
22	5100011579	Interruttore	Interruptor	Switch		1	pc
23	5100023546	Bilanciere, preselezione	Soporte basic., preselección	Rocker, preselection		1	pc
24	5100023038	Bilanciere, cambio marcia	Soporte basic., cambio marchas	Rocker, gear shifting		1	pc
30	5100023242	Fissaggio	Fijación	Fixation		1	pc
31	5100023241	Sonda a pulsante	Pulsador	Push button		1	pc
33	5100023527	Lama	Etiqueta	Label		1	pc
35	5100023008	Coperchio	Tapa	Lid		1	pc
100	5100025933	Cruscotto	Panel de instrumentos	Instrument panel		1	pc



Impianto elettrico
Sistema electrico
Electrical system

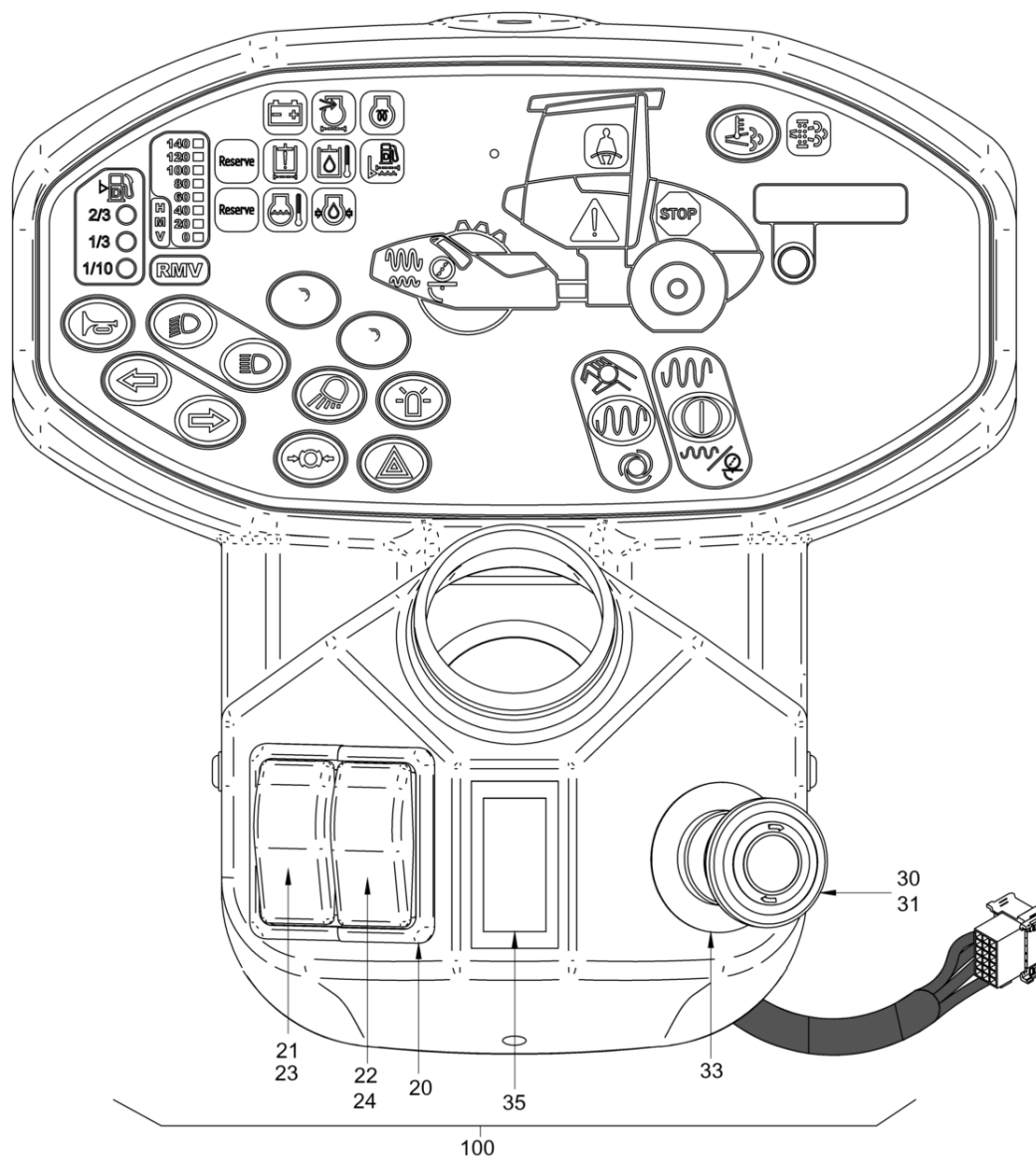
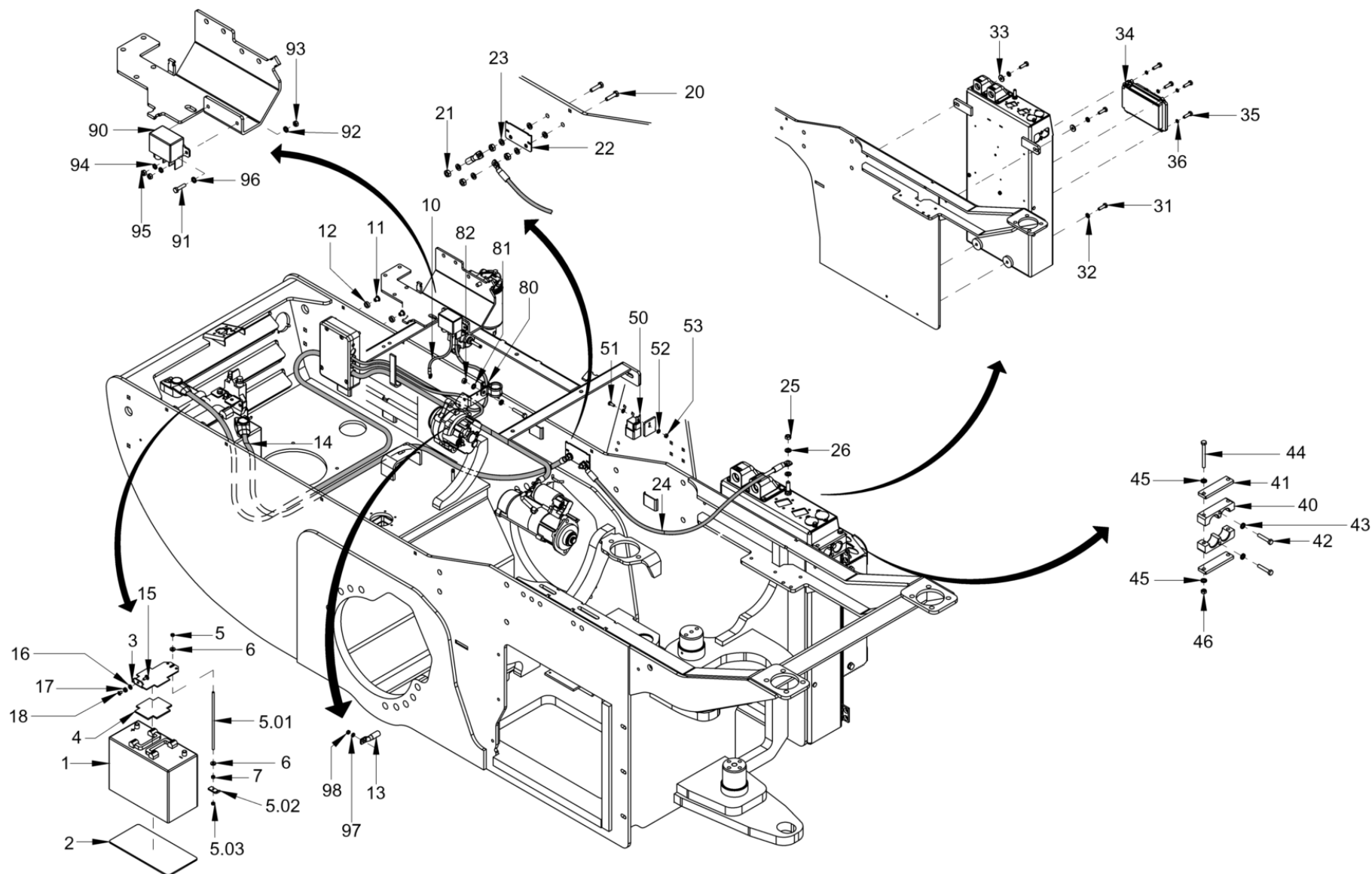

Impianto elettrico
Sistema electrico
Electrical system

Item	Item no.	Descrizione	Descripción	Description	Information	Pc.	Unit
1	5100023225	Batteria	Batería	Battery		1	pc
2	5100023236	Spessore	Chapa de asiento	Supporting plate		1	pc
3	5100048639	Supporto	Soporte	Holder		1	pc
4	5100023238	Spessore	Chapa de asiento	Supporting plate		1	pc
5	5100012546	Dado esagonale	Tuerca hexagonal	Hexagon nut	5.03	2	pc
5	5100023360	Barra filettata	Varilla roscada	Threaded rod	5.01	1	pc
5	5100023361	Linguetta	Esclisa	Strap	5.02	1	pc
5	5100040586	Supporto batteria	Soporte batería	Battery support		1	pc
6	5100013257	Rondella	Arandela	Washer		2	pc
7	5100012546	Dado esagonale	Tuerca hexagonal	Hexagon nut		1	pc
10	5100025894	Gruppo di cavi elettrici	Mazo de cables	Cable harness		1	pc
11	5100023404	Dado	Tuerca	Nut		4	pc
12	5100023077	Rondella a u	Disco en u	U-washer		4	pc
13	5100070705	Fascio di cavi	Mazo de cables	Cable harness		1	pc
14	5100023413	Cavo batteria	Cable de batería	Battery cable		1	pc
15	5100053034	Vite a testa tonda	Tornillo cil. cabeza rebajada	Mushroom head screw		1	pc
16	5100012939	Rondella	Arandela	Washer		1	pc
17	5100023077	Rondella a u	Disco en u	U-washer		1	pc
18	5100023404	Dado	Tuerca	Nut		1	pc
20	5100023469	Bullone esagonale	Tornillo hexagonal	Hexagon screw		2	pc
21	5100023124	Dado esagonale	Tuerca hexagonal	Hexagonal nut		4	pc
22	5100023467	Lamiera	Chapa	Metal plate		1	pc
23	5100011918	Rondella dent.	Arandela elástica dentada	Serrated lock washer		6	pc
24	5100070706	Fascio di cavi	Mazo de cables	Cable harness		1	pc
25	5100023124	Dado esagonale	Tuerca hexagonal	Hexagonal nut		1	pc
26	5100011918	Rondella dent.	Arandela elástica dentada	Serrated lock washer		2	pc
31	5100013416	Bullone esagonale	Tornillo hexagonal	Hexagon screw		4	pc
32	5100012967	Rondella di sicurezza	Disco de seguridad	Locking washer		4	pc
33	5100013128	Rondella	Arandela	Washer		2	pc
34	5100070707	Dispositivo di guida	Unidad de control	Control device		1	pc
35	5100023420	Bullone esagonale	Tornillo hexagonal	Hexagon screw		4	pc
36	5100011917	Rondella dent.	Arandela elástica dentada	Serrated lock washer		4	pc
40	5100023376	Mezzo morsetto	Media abrazadera	Half-clip		2	pc
41	5100023375	Barra piatta di acciaio	Acero plano	Flat steel		2	pc
42	5100034968	Bullone esagonale	Tornillo hexagonal	Hexagon screw		2	pc
43	5100012966	Rondella di sicurezza	Disco de seguridad	Locking washer		2	pc

Impianto elettrico
Sistema electrico
Electrical system

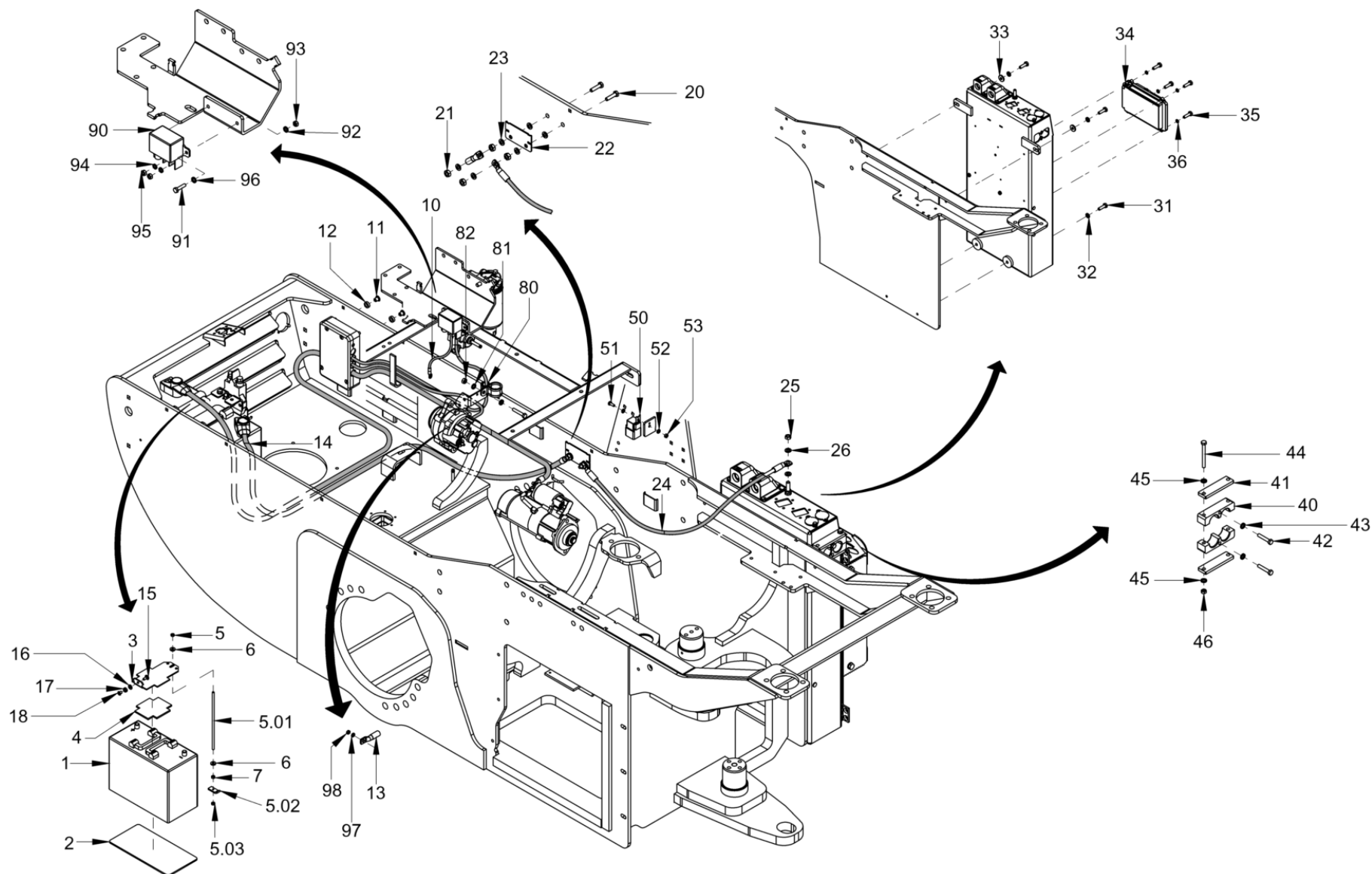

Impianto elettrico
Sistema electrico
Electrical system

Item	Item no.	Descrizione	Descripción	Description	Information	Pc.	Unit
44	5100023200	Bullone esagonale	Tornillo hexagonal	Hexagon screw		2	pc
45	5100012966	Rondella di sicurezza	Disco de seguridad	Locking washer		4	pc
46	5100012546	Dado esagonale	Tuerca hexagonal	Hexagon nut		2	pc
50	5100023218	Relè	Rele	Relay		1	pc
51	5100012600	Bullone esagonale	Tornillo hexagonal	Hexagon screw		1	pc
52	5100012965	Rondella di sicurezza	Disco de seguridad	Locking washer		2	pc
53	5100012545	Dado esagonale	Tuerca hexagonal	Hexagon nut		1	pc
80	5100011465	Morsetto per tubi	Abrazadera	Pipe clip		1	pc
81	5100012966	Rondella di sicurezza	Disco de seguridad	Locking washer		1	pc
82	5100012546	Dado esagonale	Tuerca hexagonal	Hexagon nut		1	pc
90	5100011633	Relè	Rele	Relay		1	pc
91	5100012610	Bullone esagonale	Tornillo hexagonal	Hexagon screw		2	pc
92	5100012965	Rondella di sicurezza	Disco de seguridad	Locking washer		2	pc
93	5100017998	Dado esagonale	Tuerca hexagonal	Hexagonal nut		2	pc
94	5100023629	Rondella elastica	Arandela elástica	Spring ring		2	pc
95	5100011914	Dado esagonale	Tuerca hexagonal	Hexagon nut		2	pc
96	5100011636	Rondella	Arandela	Washer		2	pc
97	5100012937	Rondella	Arandela	Washer		1	pc
98	5100017998	Dado esagonale	Tuerca hexagonal	Hexagonal nut		1	pc

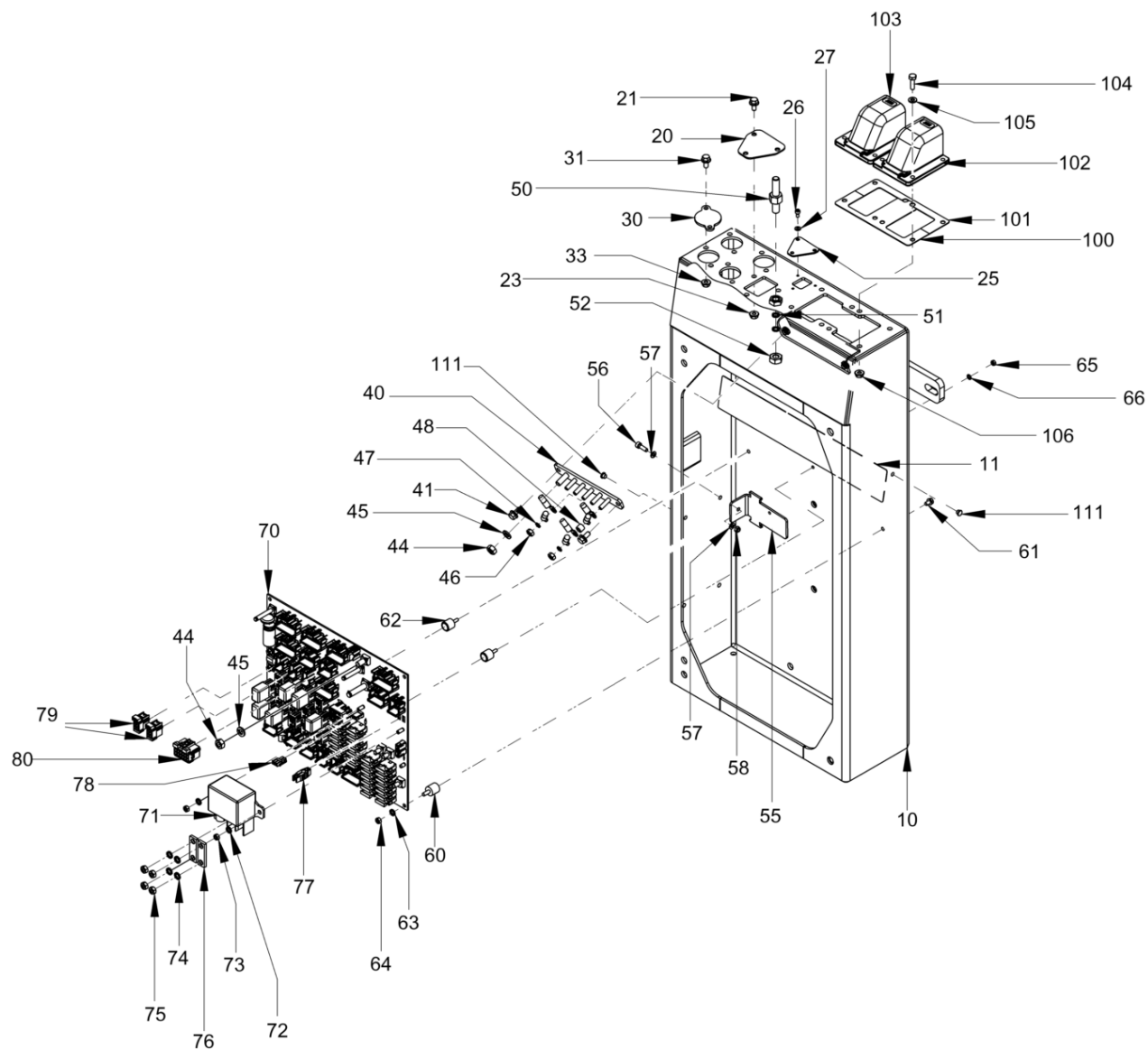

Impianto elettrico
Sistema electrico
Electrical system

Item	Item no.	Descrizione	Descripción	Description	Information	Pc.	Unit
10	5100070708	Cassetta	Caja	Case		1	pc
11	5100070710	Protezione per cavi	Protección de cable	Protective covering of cables		1	pc
20	5100023216	Coperchio	Tapa	Lid		1	pc
21	5100023164	Vite di sicurezza	Tornillo de seguridad	Safety screw		3	pc
23	5100023132	Dado esagonale	Tuerca hexagonal	Hexagonal nut		3	pc
25	5100070711	Lamiera	Chapa	Metal plate		1	pc
26	5100013411	Vite a testa cilindrica	Tornillo cilíndrico	Cheese-head screw		3	pc
27	5100013438	Rondella	Arandela	Washer		3	pc
30	5100023109	Coperchio	Chapa de recubrimiento	Cover sheet		4	pc
31	5100023164	Vite di sicurezza	Tornillo de seguridad	Safety screw		8	pc
33	5100023132	Dado esagonale	Tuerca hexagonal	Hexagonal nut		8	pc
40	5100011974	Morsetto di terra	Borne de toma de tierra	Ground terminal		1	pc
41	5100023164	Vite di sicurezza	Tornillo de seguridad	Safety screw		2	pc
44	5100011915	Dado esagonale	Tuerca hexagonal	Hexagon nut		2	pc
45	5100011917	Rondella dent.	Arandela elástica dentada	Serrated lock washer		2	pc
46	5100011914	Dado esagonale	Tuerca hexagonal	Hexagon nut		5	pc
47	5100023629	Rondella elastica	Arandela elástica	Spring ring		5	pc
48	5100011793	Boccola distanziatrice	Casquillo distanciador	Distance bush		4	pc
50	5100023466	Bullone filettato	Bulón roscado	Threaded bolt		1	pc
51	5100011918	Rondella dent.	Arandela elástica dentada	Serrated lock washer		2	pc
52	5100023124	Dado esagonale	Tuerca hexagonal	Hexagonal nut		1	pc
55	5100070712	Lamiera	Chapa	Metal plate		1	pc
56	5100022928	Vite a testa cilindrica	Tornillo cilíndrico	Cheese-head screw		1	pc
57	5100012936	Rondella	Arandela	Washer		2	pc
58	5100011599	Dado esagonale	Tuerca hexagonal	Hexagon nut		1	pc
60	5100011669	Supporti vibranti	Tope de caucho-metal	Rubber metal buffer		5	pc
61	5100013594	Vite di sicurezza	Tornillo de seguridad	Safety screw		5	pc
62	5100023145	Supporti vibranti	Tope de caucho-metal	Rubber metal buffer		2	pc
63	5100016273	Rondella dent.	Arandela elástica dentada	Serrated lock washer		5	pc
64	5100016274	Dado esagonale	Tuerca hexagonal	Hexagon nut		5	pc
65	5100022855	Dado esagonale	Tuerca hexagonal	Hexagonal nut		2	pc
66	5100022895	Rondella dent.	Arandela elástica dentada	Serrated lock washer		2	pc
70	5100070713	Elettronica centrale	Electricidad central	Central electric		1	pc
71	5100011633	Relè	Rele	Relay		1	pc
72	5100016273	Rondella dent.	Arandela elástica dentada	Serrated lock washer		2	pc
73	5100016274	Dado esagonale	Tuerca hexagonal	Hexagon nut		2	pc

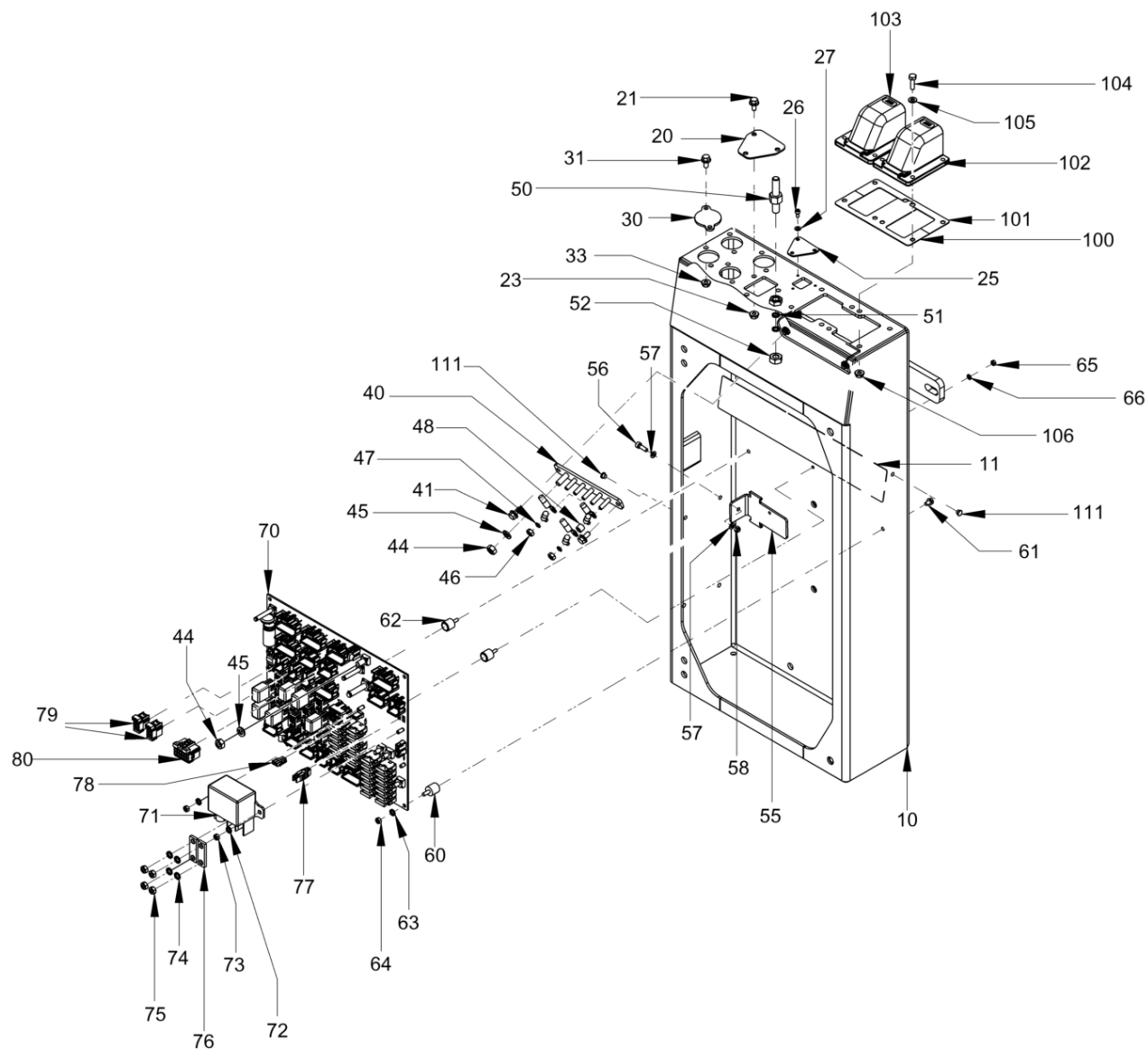

Impianto elettrico
Sistema elettrico
Electrical system

Item	Item no.	Descrizione	Descripción	Description	Information	Pc.	Unit
74	5100023629	Rondella elastica	Arandela elástica	Spring ring		4	pc
75	5100011914	Dado esagonale	Tuerca hexagonal	Hexagon nut		4	pc
76	5100023099	Binario di collegamento	Barra de conexión	Connecting bar		2	pc
77	5100011632	Estrattore per fusibili piatti	Extractor para fusibles planos	Extractor for blade fuses		1	pc
78	5100023551	Gruppo di cavi elettrici	Mazo de cables	Cable harness		1	pc
79	5100023405	Connettore di accoppiamento	Contraconector	Counterplug		2	pc
80	5100023260	Connettore di accoppiamento	Contraconector	Counterplug		1	pc
100	5100023219	Lamiera	Chapa	Metal plate		1	pc
101	5100023220	Lamiera	Chapa	Metal plate		1	pc
102	5100023377	Gruppo di cavi elettrici	Mazo de cables	Cable harness		1	pc
103	5100070715	Fascio di cavi	Mazo de cables	Cable harness		1	pc
104	5100012608	Bullone esagonale	Tornillo hexagonal	Hexagon screw		8	pc
105	5100012937	Rondella	Arandela	Washer		8	pc
106	5100023132	Dado esagonale	Tuerca hexagonal	Hexagonal nut		8	pc
111	5100023128	Tappo a vite	Tapón de cierre	Filler cap		4	pc



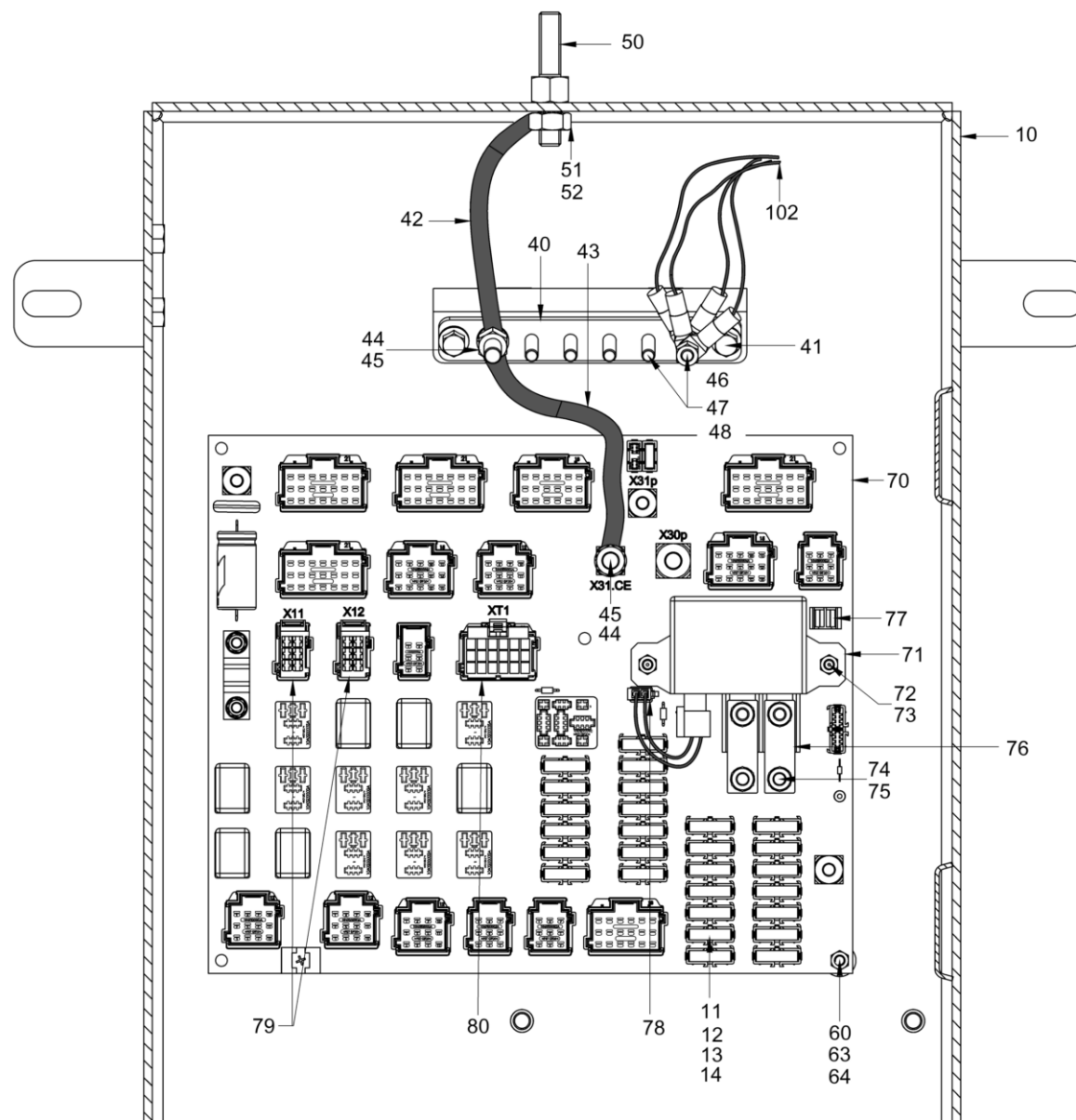

Impianto elettrico
Sistema electrico
Electrical system

Item	Item no.	Descrizione	Descripción	Description	Information	Pc.	Unit
10	5100070708	Cassetta	Caja	Case		1	pc
11	5100013586	Fusibile piatto	Fusibile plano	Blade fuse		2	pc
12	5100013579	Fusibile piatto	Fusibile plano	Blade fuse		15	pc
13	5100013580	Fusibile piatto	Fusibile plano	Blade fuse		5	pc
14	5100013587	Fusibile piatto	Fusibile plano	Blade fuse		2	pc
40	5100011974	Morsetto di terra	Borne de toma de tierra	Ground terminal		1	pc
41	5100023164	Vite di sicurezza	Tornillo de seguridad	Safety screw		2	pc
42	5100023463	Cavo di terra	Cable de toma de tierra	Ground cable		1	pc
43	5100023537	Cavo di terra	Cable de toma de tierra	Ground cable		1	pc
44	5100011915	Dado esagonale	Tuerca hexagonal	Hexagon nut		2	pc
45	5100011917	Rondella dent.	Arandela elástica dentada	Serrated lock washer		2	pc
46	5100011914	Dado esagonale	Tuerca hexagonal	Hexagon nut		2	pc
47	5100023629	Rondella elastica	Arandela elástica	Spring ring		2	pc
48	5100011793	Boccola distanziatrice	Casquillo distanciador	Distance bush		2	pc
50	5100023466	Bullone filettato	Bulón roscado	Threaded bolt		1	pc
51	5100011918	Rondella dent.	Arandela elástica dentada	Serrated lock washer		2	pc
52	5100023124	Dado esagonale	Tuerca hexagonal	Hexagonal nut		1	pc
60	5100011669	Supporti vibranti	Tope de caucho-metal	Rubber metal buffer		5	pc
63	5100016273	Rondella dent.	Arandela elástica dentada	Serrated lock washer		5	pc
64	5100016274	Dado esagonale	Tuerca hexagonal	Hexagon nut		5	pc
70	5100070713	Elettronica centrale	Electricidad central	Central electric		1	pc
71	5100011633	Relè	Relè	Relay		1	pc
72	5100016273	Rondella dent.	Arandela elástica dentada	Serrated lock washer		2	pc
73	5100016274	Dado esagonale	Tuerca hexagonal	Hexagon nut		2	pc
74	5100023629	Rondella elastica	Arandela elástica	Spring ring		4	pc
75	5100011914	Dado esagonale	Tuerca hexagonal	Hexagon nut		4	pc
76	5100023099	Binario di collegamento	Barra de conexión	Connecting bar		2	pc
77	5100011632	Estrattore per fusibili piatti	Extractor para fusibles planos	Extractor for blade fuses		1	pc
78	5100023551	Gruppo di cavi elettrici	Mazo de cables	Cable harness		1	pc
79	5100023405	Connettore di accoppiamento	Contraconector	Counterplug		2	pc
80	5100023260	Connettore di accoppiamento	Contraconector	Counterplug		1	pc
102	5100023377	Gruppo di cavi elettrici	Mazo de cables	Cable harness		1	pc



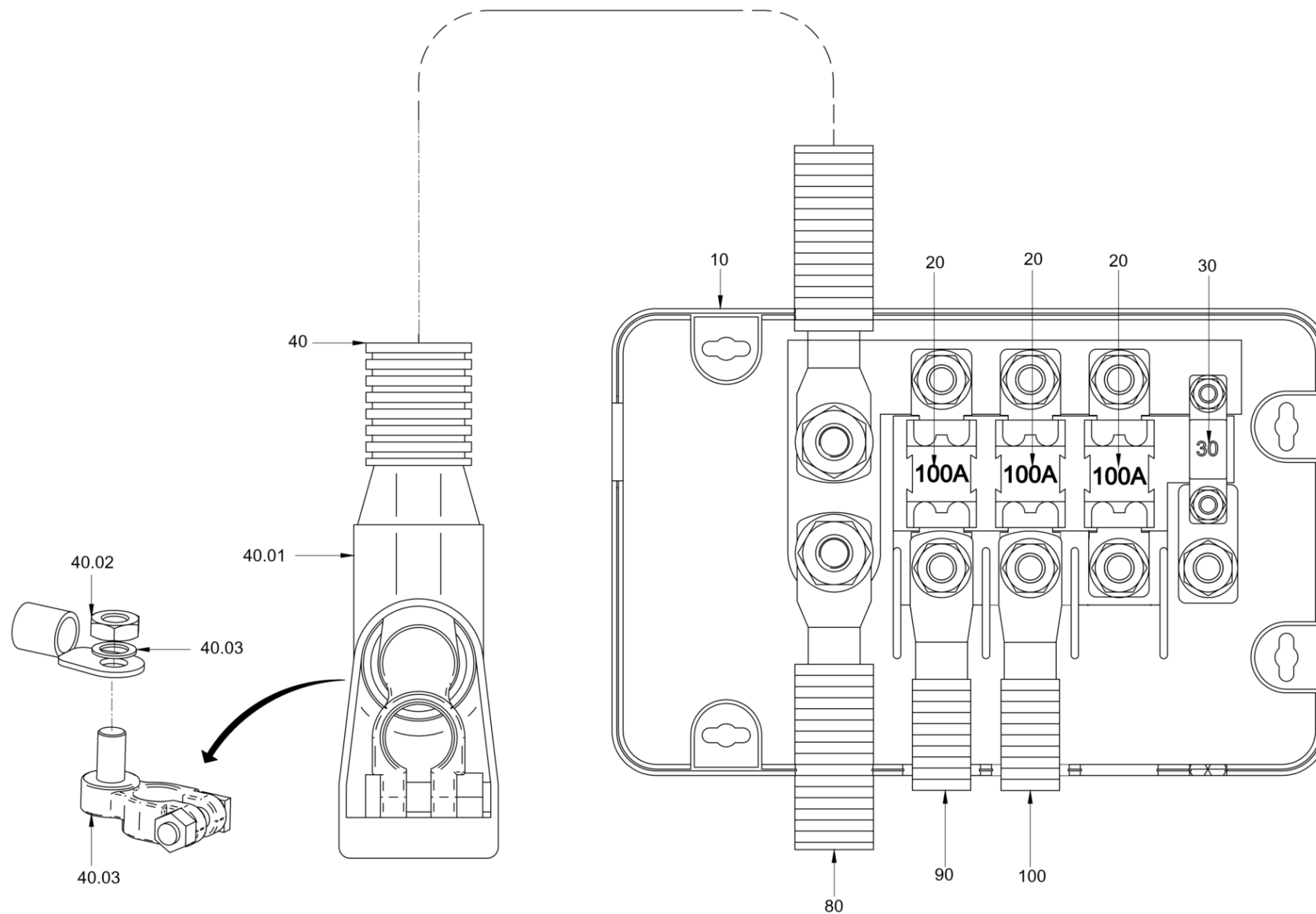

Impianto elettrico
Sistema electrico
Electrical system

Item	Item no.	Descrizione	Descripción	Description	Information	Pc.	Unit
10	5100023097	Scatola dei fusibili	Caja de fusibles	Fuse socket		1	pc
20	5100023053	Fusibile	Fusible	Fuse		3	pc
20	5100046043	Fusibile	Fusible	Fuse		3	pc
30	5100023209	Fusibile piatto	Fusible plano	Blade-type fuse		1	pc
40	5100013440	Rondella di sicurezza	Disco de seguridad	Locking washer		1	pc
40	5100022880	Morsetto della batteria plus	Borne de batería positivo	Battery terminal positive		1	pc
40	5100023208	Tappo di copertura	Capacete de protección	Protecting cap		1	pc
40	5100023412	Cavo batteria	Cable de batería	Battery cable		1	pc
80	5100023411	Cavo batteria	Cable de batería	Battery cable		1	pc
90	5100023414	Gruppo di cavi elettrici	Mazo de cables	Cable harness		1	pc
100	5100023415	Gruppo di cavi elettrici	Mazo de cables	Cable harness		1	pc



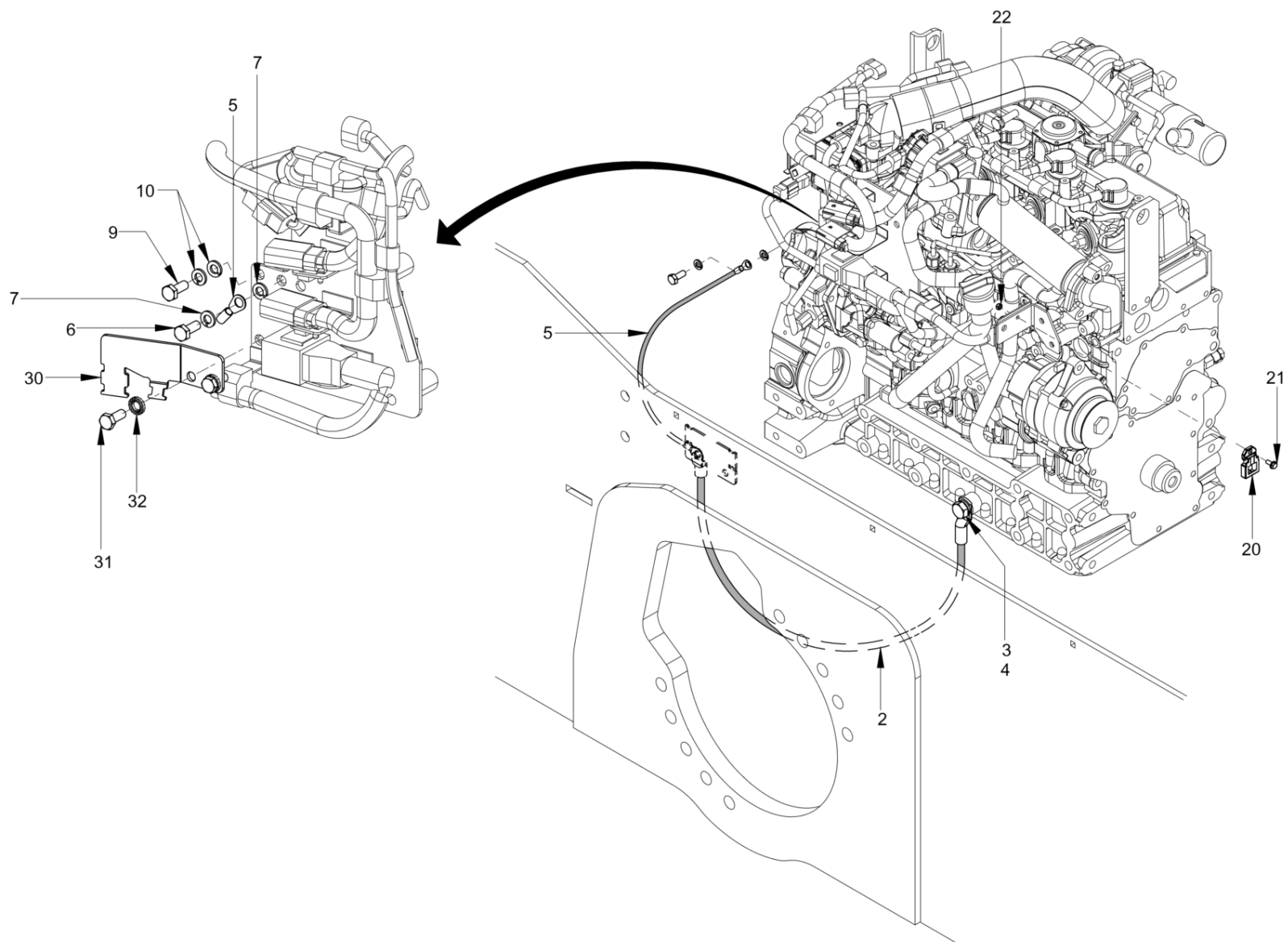

Impianto elettrico
Sistema electrico
Electrical system

Item	Item no.	Descrizione	Descripción	Description	Information	Pc.	Unit
2	5100023439	Cavo di terra	Cable de toma de tierra	Ground cable		1	pc
3	5100023470	Bullone esagonale	Tornillo hexagonal	Hexagon screw		1	pc
4	5100023416	Rondella elastica	Arandela elástica	Spring ring		2	pc
5	5100023442	Cavo di terra	Cable de toma de tierra	Ground cable		1	pc
6	5100023420	Bullone esagonale	Tornillo hexagonal	Hexagon screw		1	pc
6	5100023420	Bullone esagonale	Tornillo hexagonal	Hexagon screw		1	pc
7	5100011917	Rondella dent.	Arandela elástica dentada	Serrated lock washer		2	pc
7	5100011917	Rondella dent.	Arandela elástica dentada	Serrated lock washer		2	pc
9	5100023420	Bullone esagonale	Tornillo hexagonal	Hexagon screw		1	pc
10	5100011917	Rondella dent.	Arandela elástica dentada	Serrated lock washer		2	pc
20	5100023158	Piastre di estensione	Placa montaje posterior	Attachment plate		1	pc
21	5100012587	Vite di sicurezza	Tornillo de seguridad	Safety screw		1	pc
22	5100011599	Dado esagonale	Tuerca hexagonal	Hexagon nut		1	pc
30	5100070716	Lamiera	Chapa	Metal plate		1	pc
31	5100012517	Bullone esagonale	Tornillo hexagonal	Hexagon screw		2	pc
32	5100012966	Rondella di sicurezza	Disco de seguridad	Locking washer		2	pc



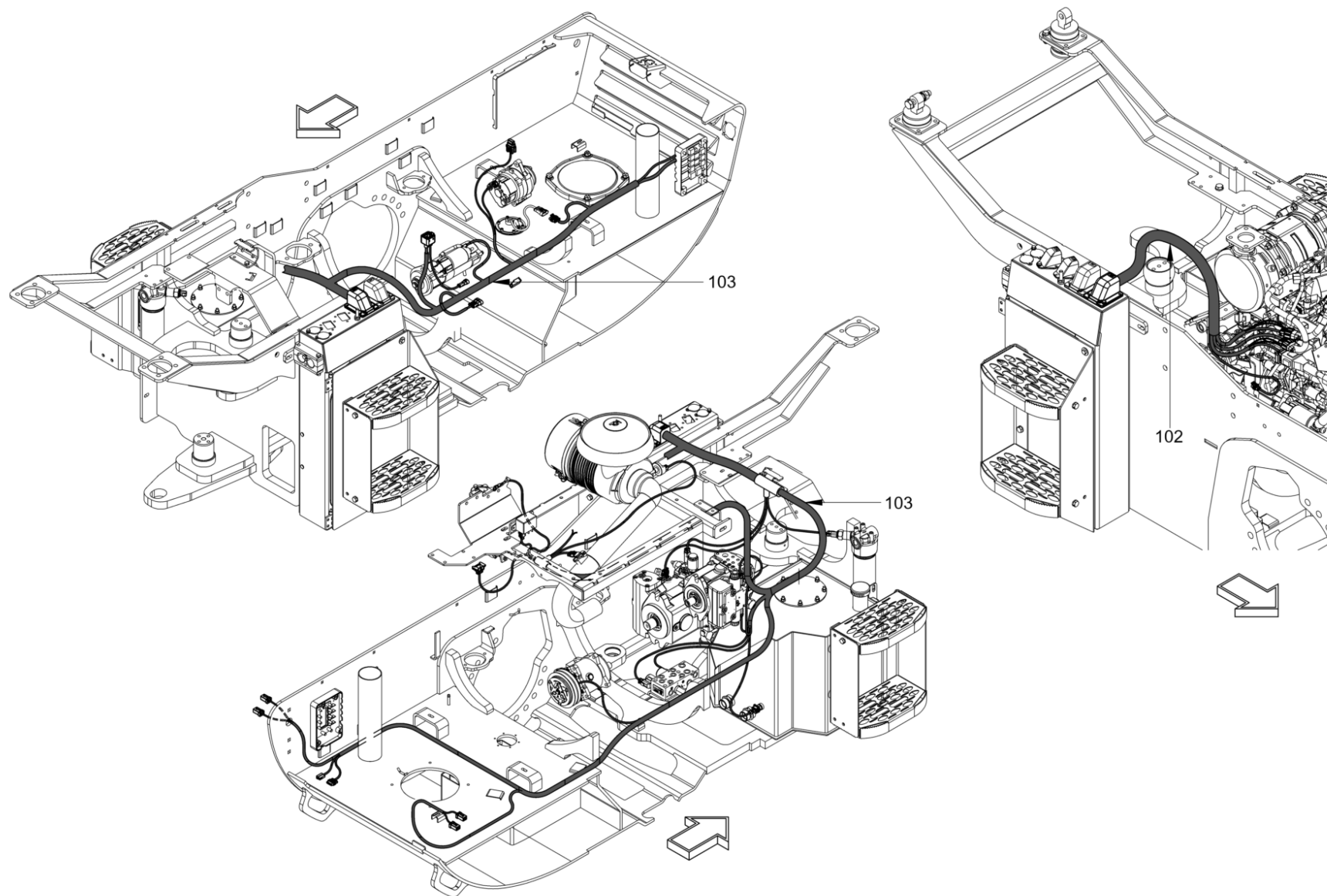

Impianto elettrico
Sistema electrico
Electrical system

Item	Item no.	Descrizione	Descripción	Description	Information	Pc.	Unit
102	5100023377	Gruppo di cavi elettrici	Mazo de cables	Cable harness		1	pc
103	5100070715	Fascio di cavi	Mazo de cables	Cable harness		1	pc



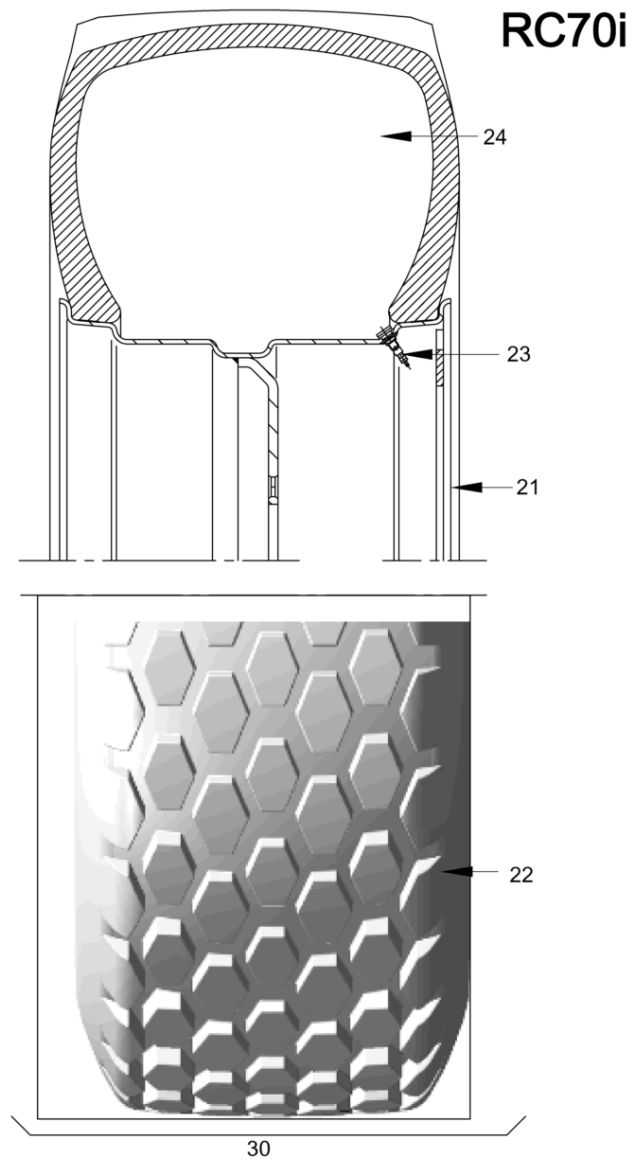
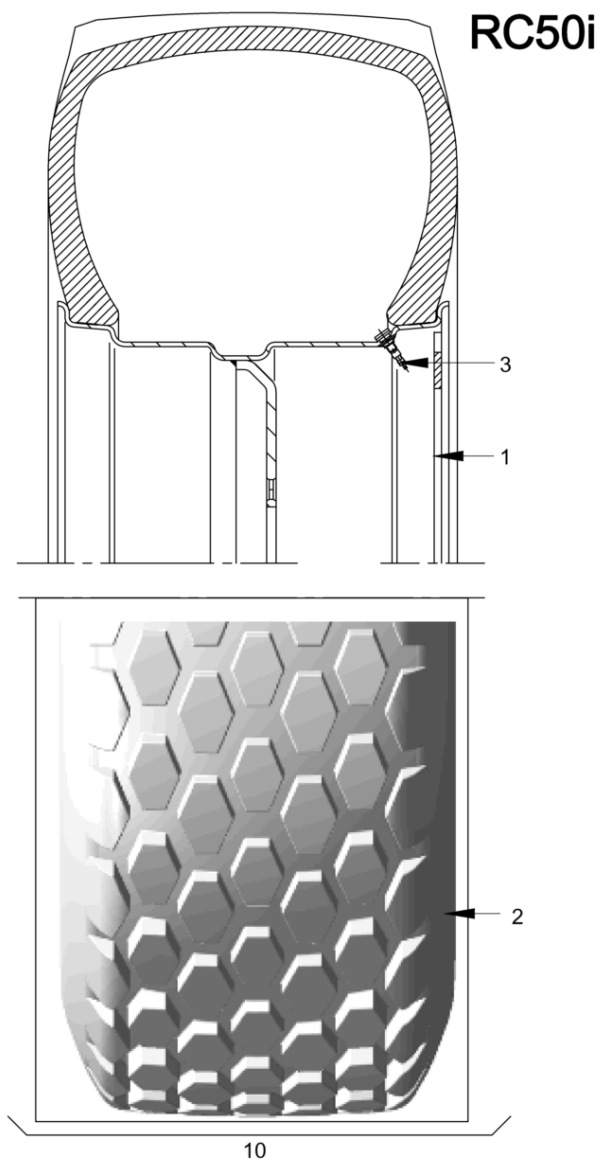

Equipaggiamento pneumatici
Neumáticos
Tyre equipment

Item	Item no.	Descrizione	Descripción	Description	Information	Pc.	Unit
1	5100025970	Ruota a disco rc50	Llanta rc50	Disc wheel rc50		1	pc
2	5100025939	Pneumatici battistrada	Neumáticos perfilados	Profile tires		1	pc
3	5100013507	Valvola del pneumatico rc50	Válvula de neumático rc50	Tyre valve rc50		1	pc
10	5100026017	Ruota cpl. rc50	Rueda cpl. rc50	Wheel cpl. rc50		2	pc
21	5100025967	Ruota a disco rc70	Llanta rc70	Disc wheel rc70		1	pc
22	5100070717	Pneumatico scolpito	Neumáticos perfilados	Profile tires		1	pc
23	5100013507	Valvola del pneumatico rc50	Válvula de neumático rc50	Tyre valve rc50		1	pc
24	5100035531	Cloruro di magnesio	Cloruro magnésico	Magnesium chloride		25	kg
30	5100070718	Pneumatico	Neumático	Tyre		2	pc



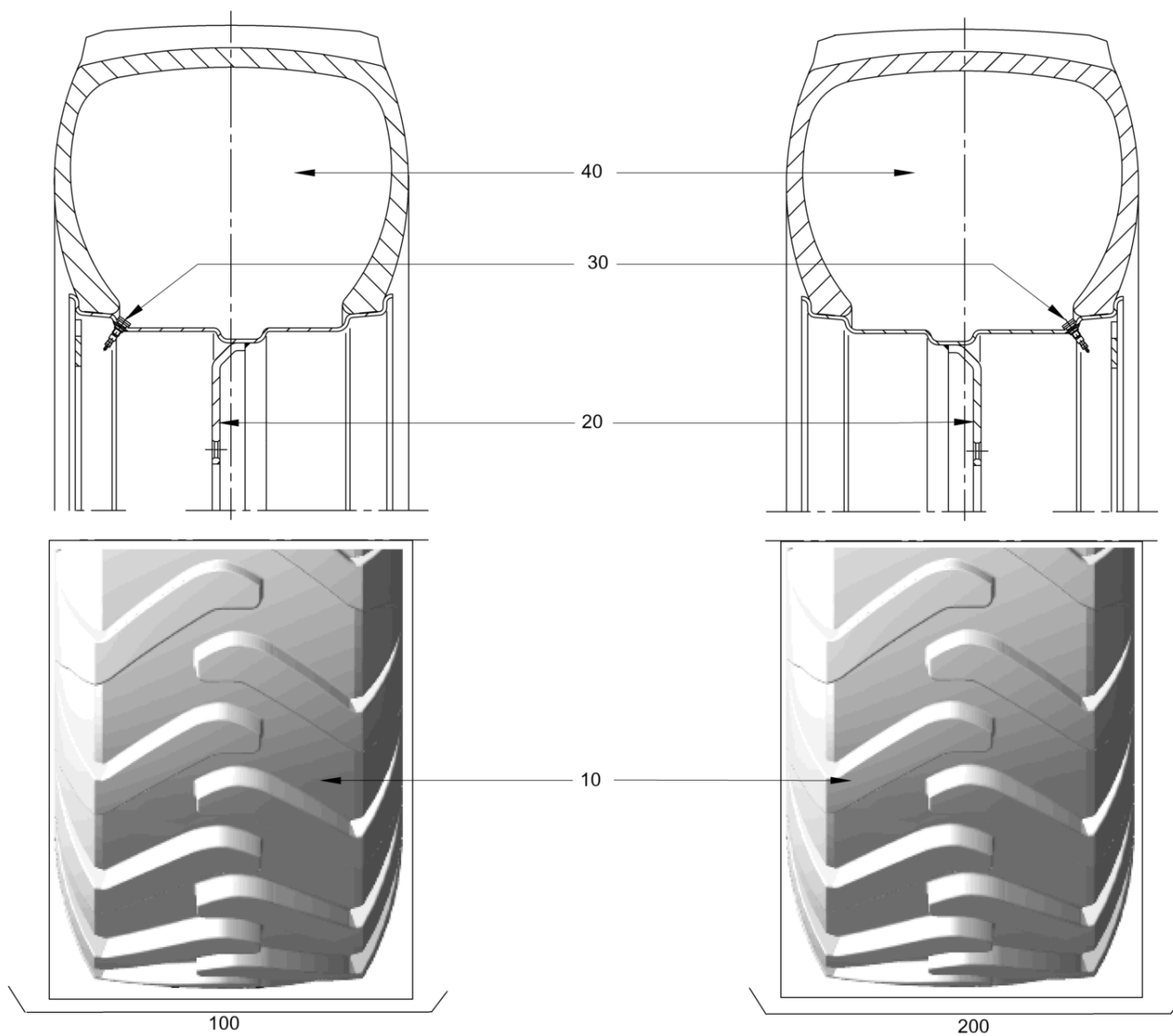

Equipaggiamento pneumatici
Neumáticos
Tyre equipment

Item	Item no.	Descrizione	Descripción	Description	Information	Pc.	Unit
10	5100022926	Pneumatici battistrada rc50	Neumáticos perfilados rc50	Profile tires rc50		1	pc
10	5100070719	Pneumatico scolpito	Neumáticos perfilados	Profile tires		1	pc
20	5100025967	Ruota a disco rc70	Llanta rc70	Disc wheel rc70		1	pc
20	5100025970	Ruota a disco rc50	Llanta rc50	Disc wheel rc50		1	pc
30	5100013507	Valvola del pneumatico rc50	Válvula de neumático rc50	Tyre valve rc50		1	pc
40	5100035531	Cloruro di magnesio	Cloruro magnésico	Magnesium chloride		25	kg
100	5100025968	Ruota sinistra rc50	Rueda izquierda rc50	Wheel left rc50		1	pc
100	5100070720	Testo non presente	Ningún texto disponible	No text available		1	pc
200	5100025969	Ruota destra rc50	Rueda derecha rc50	Wheel right rc50		1	pc
200	5100070749	Testo non presente	Ningún texto disponible	No text available		1	pc



Trazione
Accionamiento de avance
Advance drive

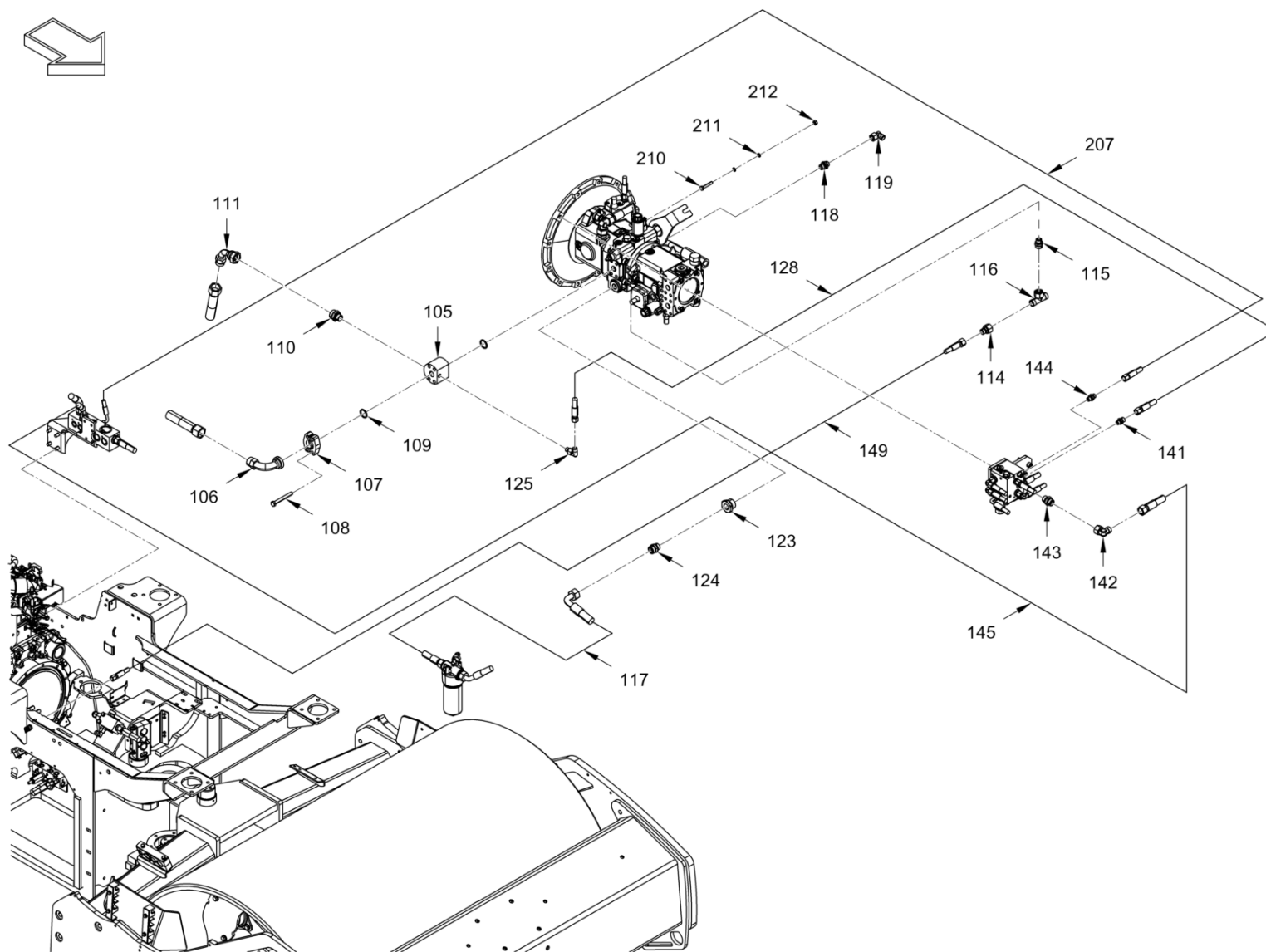

Trazione
Accionamiento de avance
Advance drive

Item	Item no.	Descrizione	Descripción	Description	Information	Pc.	Unit
105	5100022957	Piastra di collegamento	Placa de conexión	Joint plate		1	pc
106	5100023037	Gomito	Codo del tubo	Pipe elbow		1	pc
107	5100013430	Metà flangia sae	Mitad de la brida sae	Sae-flange half		2	pc
108	5100022991	Bullone esagonale	Tornillo hexagonal	Hexagon screw		4	pc
109	5100013431	Anello a o	Anillo toroidal	O-ring seal		2	pc
110	5100023103	Presa a vite dritta	Racor para enroscar recto	Straight screwed socket		1	pc
111	5100023601	Pezzo intermedio	Pieza intermedia	Intermediate piece		1	pc
114	5100022888	Inserito di riduzione	Reductor	Reducing insert		1	pc
115	5100013473	Presa a vite dritta	Racor para enroscar recto	Straight screwed socket		1	pc
116	5100013480	Connettore a t regolabile	Pieza en t ajustable	T-piece adjustable		1	pc
117	5100070760	Tubo flessibile	Manguera	Hose		1	pc
118	5100022945	Presa a vite dritta	Racor para enroscar recto	Straight screwed socket		1	pc
119	5100013619	Connettore a gomito regolabile	Racor angular ajustable	Elbow adjustable		1	pc
123	5100012091	Connettore di riduzione	Racor reductor	Reducing piece		1	pc
124	5100013471	Presa a vite dritta	Racor para enroscar recto	Straight screwed socket		1	pc
125	5100070771	Supporto angolare regolabile	Racor angular ajustable	Elbow adjustable		1	pc
128	5100070782	Tubo flessibile	Manguera	Hose		1	pc
141	5100013474	Presa a vite dritta	Racor para enroscar recto	Straight screwed socket		2	pc
142	5100013483	Connettore a gomito regolabile	Racor angular ajustable	Elbow adjustable		1	pc
143	5100013476	Presa a vite dritta	Racor para enroscar recto	Straight screwed socket		1	pc
144	5100013454	Presa a vite dritta	Racor para enroscar recto	Straight screwed socket		1	pc
145	5100070793	Tubo flessibile	Manguera	Hose		1	pc
149	5100070804	Tubo flessibile	Manguera	Hose		1	pc
207	5100070815	Tubo flessibile	Manguera	Hose		1	pc
210	5100034968	Bullone esagonale	Tornillo hexagonal	Hexagon screw		1	pc
211	5100013441	Rondella di sicurezza	Disco de seguridad	Locking washer		2	pc
212	5100012546	Dado esagonale	Tuerca hexagonal	Hexagon nut		1	pc



Trazione
Accionamiento de avance
Advance drive

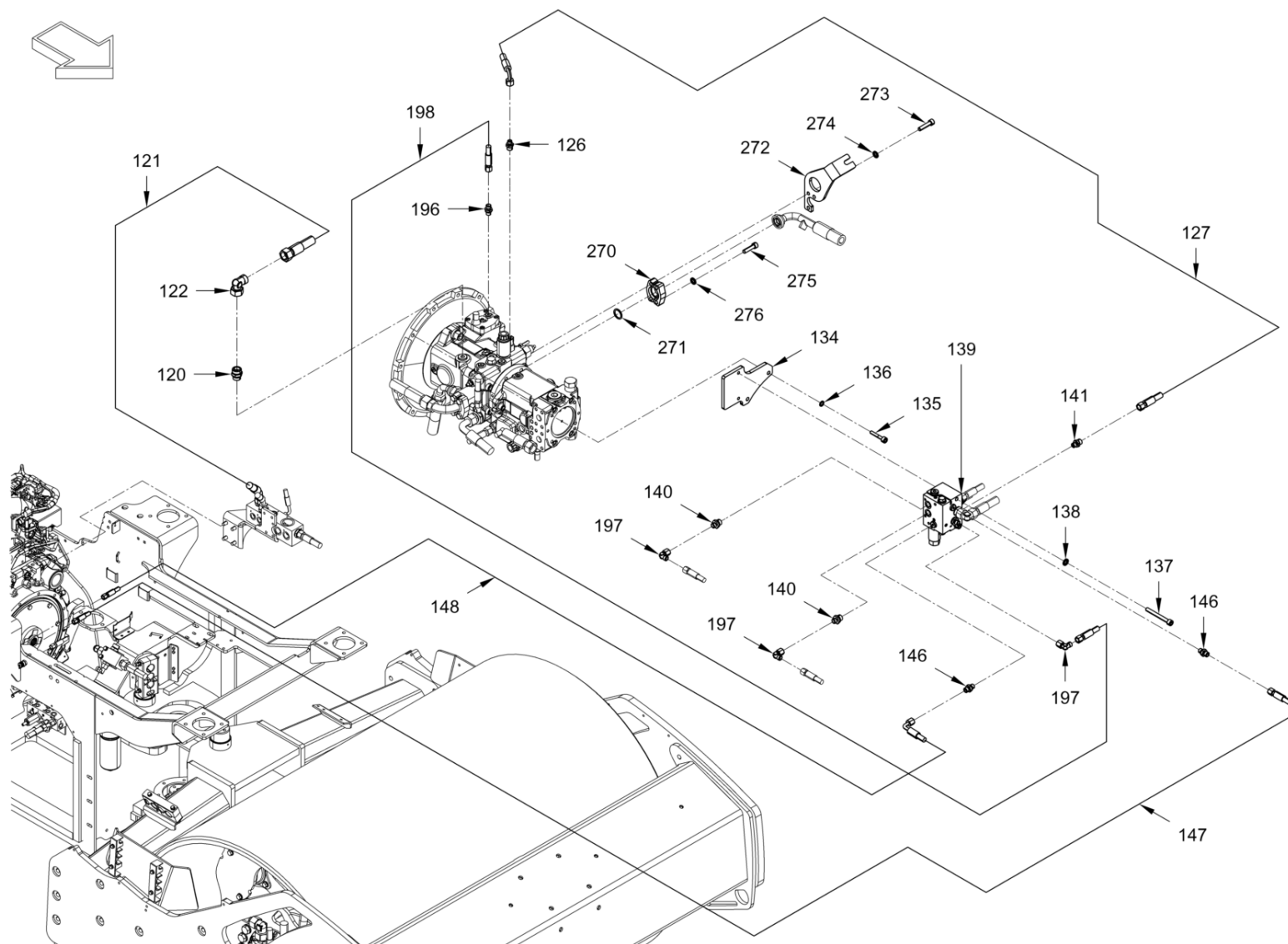

Trazione
Accionamiento de avance
Advance drive

Item	Item no.	Descrizione	Descripción	Description	Information	Pc.	Unit
120	5100013471	Presa a vite diritta	Racor para enroscar recto	Straight screwed socket		1	pc
121	5100070727	Tubo flessibile	Manguera	Hose		1	pc
122	5100022890	Connettore a gomito regolabile	Racor angular ajustable	Elbow adjustable		1	pc
126	5100013447	Presa a vite diritta	Racor para enroscar recto	Straight screwed socket		1	pc
127	5100070729	Tubo flessibile	Manguera	Hose		1	pc
134	5100070730	Supporto	Soporte	Holder		1	pc
135	5100070732	Vite a testa cilindrica	Tornillo cilíndrico	Cheese-head screw		2	pc
136	5100013440	Rondella di sicurezza	Disco de seguridad	Locking washer		2	pc
137	5100048632	Vite a testa cilindrica	Tornillo cilíndrico	Cheese-head screw		2	pc
138	5100012967	Rondella di sicurezza	Disco de seguridad	Locking washer		2	pc
139	5100048694	Valvola di scarico	Válvula de enjuague	Flush valve		1	pc
140	5100048634	Presa a vite diritta	Racor para enroscar recto	Straight screwed socket		2	pc
141	5100013474	Presa a vite diritta	Racor para enroscar recto	Straight screwed socket		2	pc
146	5100022868	Presa a vite diritta	Racor para enroscar recto	Straight screwed socket		2	pc
147	5100070733	Tubo flessibile	Manguera	Hose		1	pc
148	5100070734	Tubo flessibile	Manguera	Hose		1	pc
196	5100013434	Presa a vite diritta	Racor para enroscar recto	Straight screwed socket		1	pc
197	5100029538	Connettore a gomito regolabile	Racor angular ajustable	Elbow adjustable		3	pc
198	5100070735	Tubo flessibile	Manguera	Hose		1	pc
270	5100013430	Metà flangia sae	Mitad de la brida sae	Sae-flange half		2	pc
271	5100013431	Anello a o	Anillo toroidal	O-ring seal		1	pc
272	5100070736	Supporto	Soporte	Holder		1	pc
273	5100022994	Vite a testa cilindrica	Tornillo cilíndrico	Cheese-head screw		3	pc
274	5100012967	Rondella di sicurezza	Disco de seguridad	Locking washer		3	pc
275	5100012783	Vite a testa cilindrica	Tornillo cilíndrico	Cheese-head screw		1	pc
276	5100012967	Rondella di sicurezza	Disco de seguridad	Locking washer		1	pc



Trazione
Accionamiento de avance
Advance drive

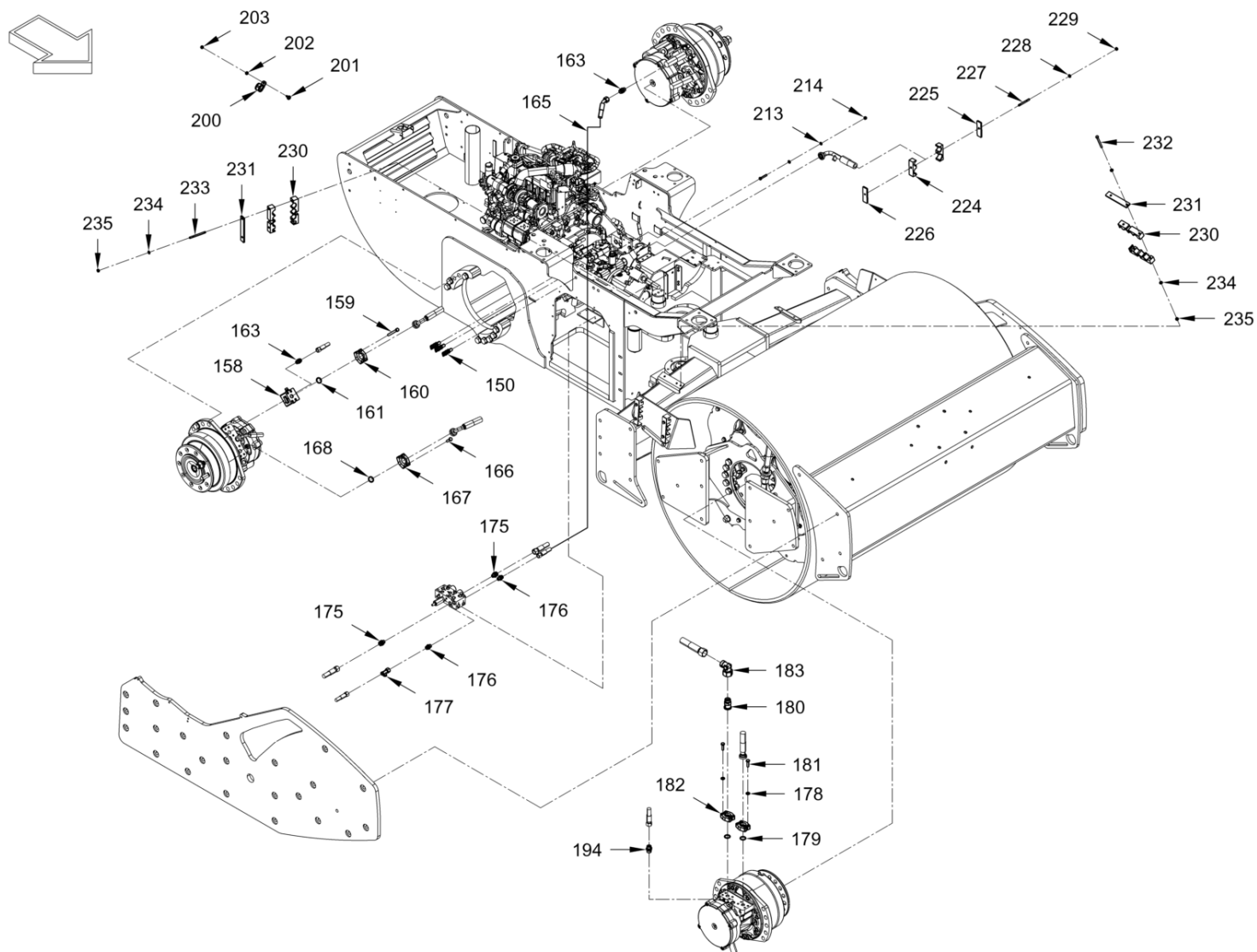

Trazione
Accionamiento de avance
Advance drive

Item	Item no.	Descrizione	Descripción	Description	Information	Pc.	Unit
150	5100023452	Raccordo di misura	Racor de medición	Measuring connection		3	pc
158	5100048695	Blocco valvole	Bloque de válvula	Valve block		2	pc
159	5100023598	Bullone esagonale	Tornillo hexagonal	Hexagon screw		8	pc
160	5100013430	Metà flangia sae	Mitad de la brida sae	Sae-flange half		4	pc
161	5100013431	Anello a o	Anillo toroïdal	O-ring seal		2	pc
163	5100013475	Presa a vite diritta	Racor para enroscar recto	Straight screwed socket		2	pc
165	5100023590	Tubo flessibile	Manguera	Hose		1	pc
166	5100013416	Bullone esagonale	Tornillo hexagonal	Hexagon screw		8	pc
167	5100013430	Metà flangia sae	Mitad de la brida sae	Sae-flange half		4	pc
168	5100013431	Anello a o	Anillo toroïdal	O-ring seal		2	pc
175	5100013603	Presa a vite diritta	Racor para enroscar recto	Straight screwed socket		2	pc
176	5100013475	Presa a vite diritta	Racor para enroscar recto	Straight screwed socket		2	pc
177	5100013613	Connettore a gomito regolabile	Racor angular ajustable	Elbow adjustable		1	pc
178	5100012967	Rondella di sicurezza	Disco de seguridad	Locking washer		8	pc
179	5100013431	Anello a o	Anillo toroïdal	O-ring seal		2	pc
180	5100022912	Supporto	Racor	Socket		1	pc
181	5100013416	Bullone esagonale	Tornillo hexagonal	Hexagon screw		8	pc
182	5100013430	Metà flangia sae	Mitad de la brida sae	Sae-flange half		4	pc
183	5100022896	Connettore a gomito regolabile	Racor angular ajustable	Elbow adjustable		1	pc
194	5100012190	Presa a vite diritta	Racor para enroscar recto	Straight screwed socket		1	pc
200	5100011470	Morsetto per tubi	Abrazadera	Pipe clip		1	pc
201	5100012780	Vite a testa tonda	Tornillo cil. cabeza rebajada	Mushroom head screw		1	pc
202	5100012966	Rondella di sicurezza	Disco de seguridad	Locking washer		1	pc
203	5100012546	Dado esagonale	Tuerca hexagonal	Hexagon nut		1	pc
213	5100012938	Rondella	Arandela	Washer		2	pc
214	5100053004	Controdado	Tuerca de seguridad	Safety nut		1	pc
224	5100023732	Collare su soffietto	Abrazadera	Hose clamp		2	pc
225	5100070737	Piastra di copertura	Placa de recubrimiento	Top cover		1	pc
226	5100070739	Piastra di copertura	Placa de recubrimiento	Top cover		1	pc
227	5100039073	Vite prigioniera	Espárrago	Stud screw		1	pc
228	5100012966	Rondella di sicurezza	Disco de seguridad	Locking washer		1	pc
229	5100012546	Dado esagonale	Tuerca hexagonal	Hexagon nut		1	pc
230	5100023357	Mezzo morsetto	Media abrazadera	Half-clip		4	pc
231	5100023351	Piastra di copertura	Placa de recubrimiento	Top cover		2	pc
232	5100040596	Vite esagonale	Tornillo hexagonal	Hexagon screw		2	pc
233	5100023211	Vite prigioniera	Espárrago	Stud screw		2	pc



Trazione
Accionamiento de avance
Advance drive

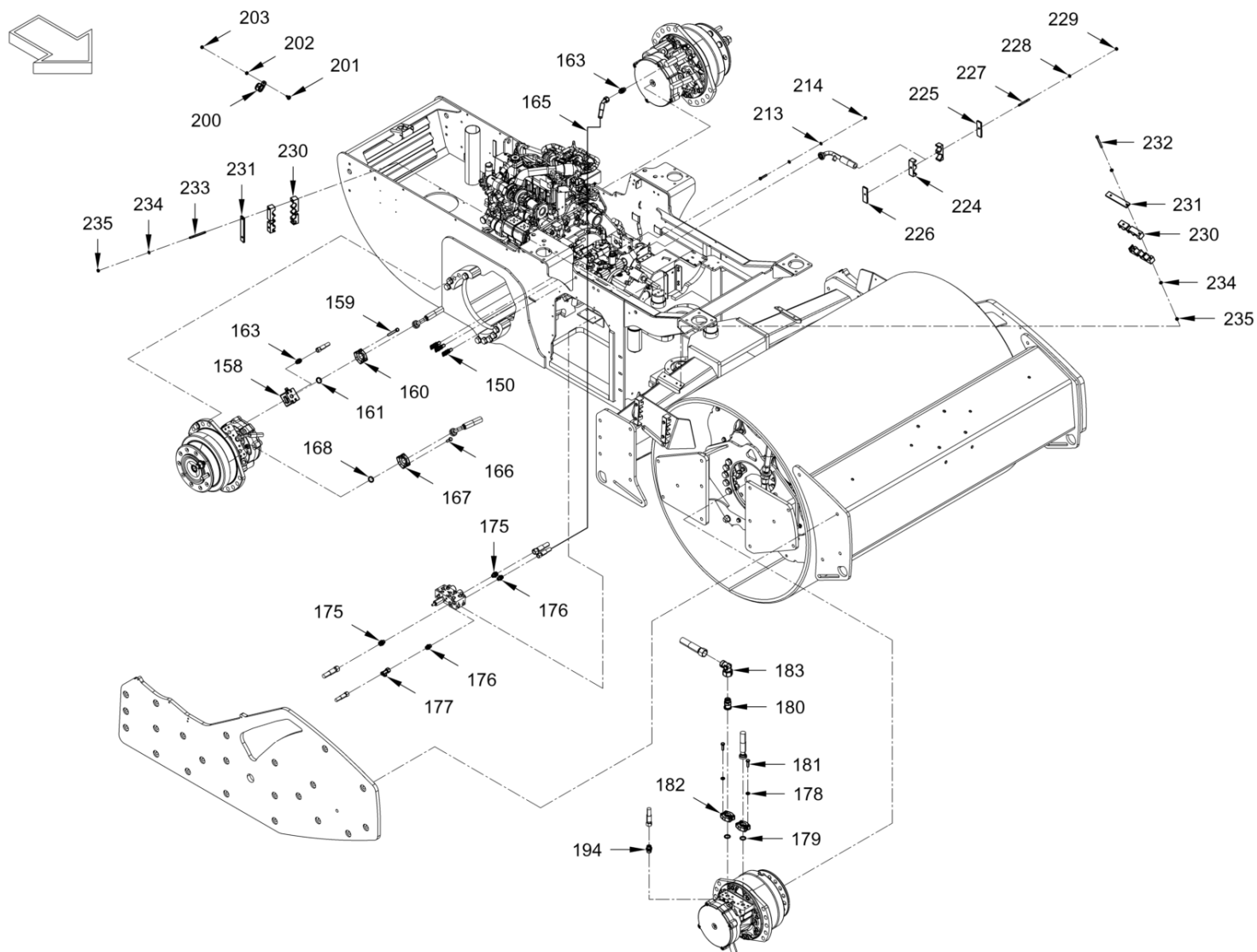

Trazione
Accionamiento de avance
Advance drive

Item	Item no.	Descrizione	Descripción	Description	Information	Pc.	Unit
234	5100012966	Rondella di sicurezza	Disco de seguridad	Locking washer		6	pc
235	5100012546	Dado esagonale	Tuerca hexagonal	Hexagon nut		4	pc



Trazione
Accionamiento de avance
Advance drive

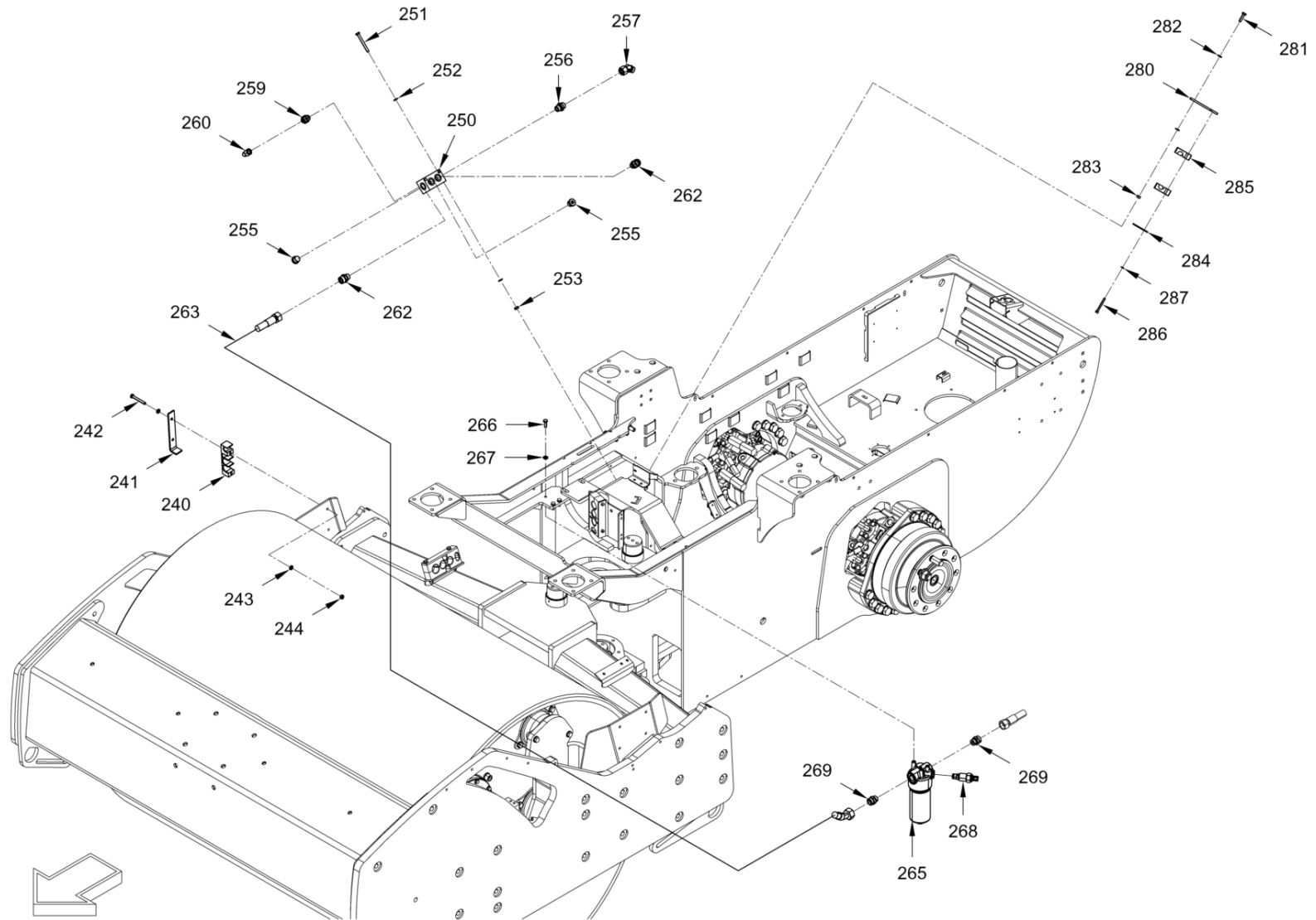

Trazione
Accionamiento de avance
Advance drive

Item	Item no.	Descrizione	Descripción	Description	Information	Pc.	Unit
240	5100023356	Mezzo morsetto	Media abrazadera	Half-clip		2	pc
241	5100023353	Piastra di copertura	Placa de recubrimiento	Top cover		2	pc
242	5100040595	Vite esagonale	Tornillo hexagonal	Hexagon screw		4	pc
243	5100012966	Rondella di sicurezza	Disco de seguridad	Locking washer		8	pc
244	5100012546	Dado esagonale	Tuerca hexagonal	Hexagon nut		4	pc
250	5100023370	Perno di raccordo	Bloque de conexión	Connecting block		1	pc
251	5100022985	Bullone esagonale	Tornillo hexagonal	Hexagon screw		2	pc
252	5100012966	Rondella di sicurezza	Disco de seguridad	Locking washer		4	pc
253	5100012546	Dado esagonale	Tuerca hexagonal	Hexagon nut		2	pc
255	5100011665	Tappo a vite	Tornillo de cierre	Screw plug		2	pc
256	5100013476	Presa a vite diritta	Racor para enroscar recto	Straight screwed socket		1	pc
257	5100012391	Connettore a gomito regolabile	Racor angular ajustable	Elbow adjustable		1	pc
259	5100013433	Presa a vite diritta	Racor para enroscar recto	Straight screwed socket		1	pc
260	5100013619	Connettore a gomito regolabile	Racor angular ajustable	Elbow adjustable		1	pc
262	5100013477	Presa a vite diritta	Racor para enroscar recto	Straight screwed socket		2	pc
263	5100023162	Tubo flessibile	Manguera	Hose		1	pc
265	5100063875	Filtro a pressione	Filtro de presión	Pressure filter		1	pc
266	5100012613	Bullone esagonale	Tornillo hexagonal	Hexagon screw		3	pc
267	5100012966	Rondella di sicurezza	Disco de seguridad	Locking washer		3	pc
268	5100023229	Indicatore di intasamento elettro.	Indicador suciedad eléctrico	Electrical filter indicator		1	pc
269	5100013471	Presa a vite diritta	Racor para enroscar recto	Straight screwed socket		2	pc
280	5100070740	Supporto	Soporte	Holder		1	pc
281	5100013510	Bullone esagonale	Tornillo hexagonal	Hexagon screw		2	pc
282	5100012966	Rondella di sicurezza	Disco de seguridad	Locking washer		4	pc
283	5100012546	Dado esagonale	Tuerca hexagonal	Hexagon nut		2	pc
284	5100070741	Supporto	Soporte	Holder		1	pc
285	5100040626	Mezzo morsetto	Media abrazadera	Half-clip		2	pc
286	5100024890	Vite a testa cilindrica	Tornillo cilíndrico	Cheese-head screw		2	pc
287	5100012965	Rondella di sicurezza	Disco de seguridad	Locking washer		2	pc



Trazione
Accionamiento de avance
Advance drive

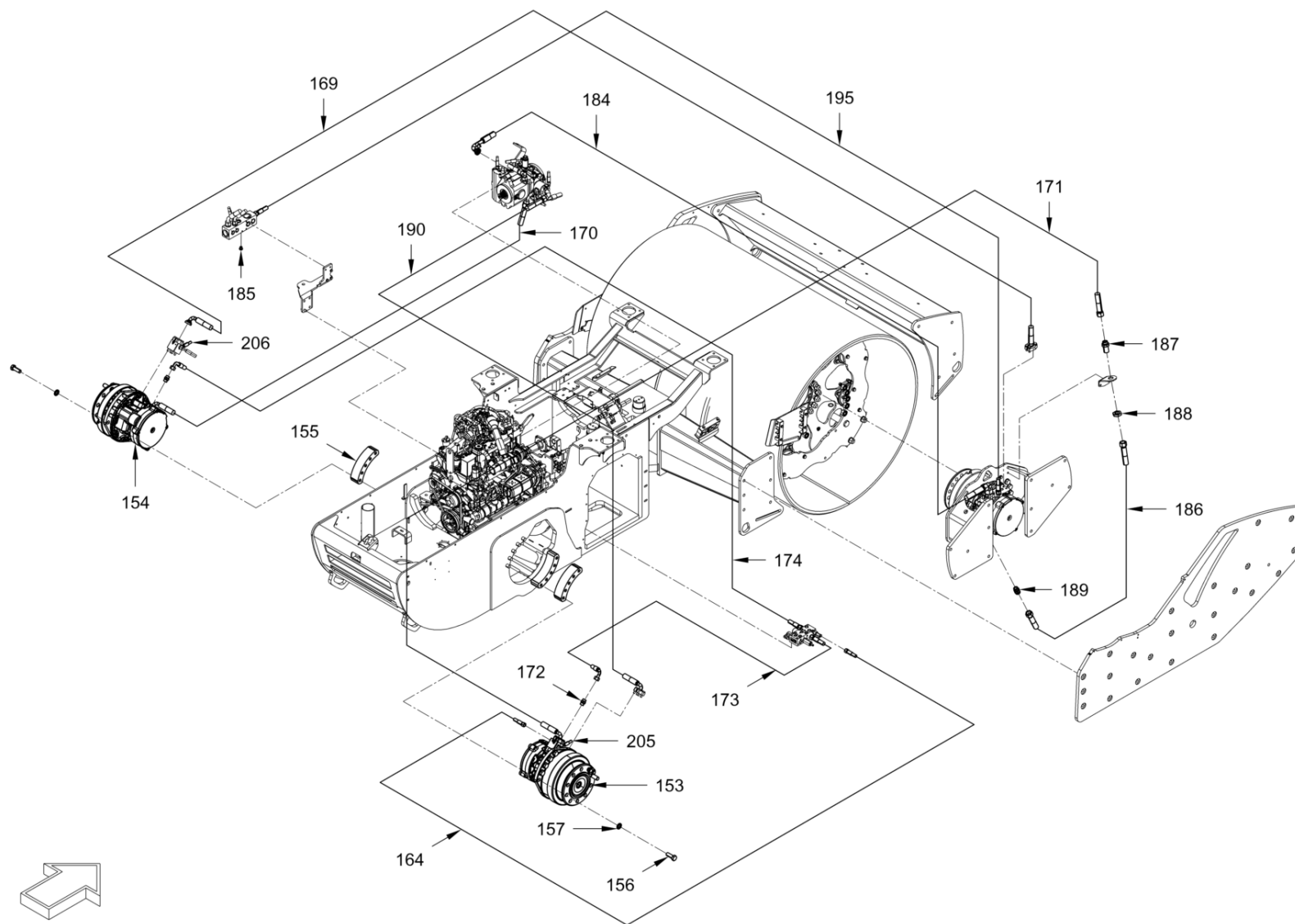

Trazione
Accionamiento de avance
Advance drive

Item	Item no.	Descrizione	Descripción	Description	Information	Pc.	Unit
153	5100070690	Motore sui mozzi delle ruote	Motor del cubo de la rueda	Gear hub motor		1	pc
154	5100070691	Motore sui mozzi delle ruote	Motor del cubo de la rueda	Gear hub motor		1	pc
155	5100023342	Distanziatore	Pieza distanciadora	Distance piece		4	pc
156	5100022910	Bullone esagonale	Tornillo hexagonal	Hexagon screw		36	pc
157	5100012955	Rondella di sicurezza	Disco de seguridad	Locking washer		36	pc
164	5100070742	Tubo flessibile	Manguera	Hose		1	pc
169	5100070744	Tubo flessibile	Manguera	Hose		1	pc
170	5100023612	Tubo flessibile	Manguera	Hose		1	pc
171	5100070745	Tubo flessibile	Manguera	Hose		1	pc
172	5100013473	Presa a vite diritta	Racor para enroscar recto	Straight screwed socket		2	pc
173	5100023628	Tubo flessibile	Manguera	Hose		1	pc
174	5100023410	Tubo flessibile	Manguera	Hose		1	pc
184	5100023476	Tubo flessibile	Manguera	Hose		1	pc
185	5100011608	Tappo a vite	Tornillo de cierre	Screw plug		1	pc
186	5100023517	Tubo flessibile	Manguera	Hose		1	pc
187	5100022893	Connettore passaparete dritto	Racor recto de mampara	Bulkhead socket straight		1	pc
188	5100022894	Dado esagonale	Tuerca hexagonal	Hexagonal nut		1	pc
189	5100022911	Presa a vite diritta	Racor para enroscar recto	Straight screwed socket		1	pc
190	5100023516	Tubo flessibile	Manguera	Hose		1	pc
195	5100023151	Tubo flessibile	Manguera	Hose		1	pc
205	5100070746	Tubo flessibile	Manguera	Hose		1	pc
206	5100070747	Tubo flessibile	Manguera	Hose		1	pc



Idraulica freni
Freno hidráulico
Brake hydraulics

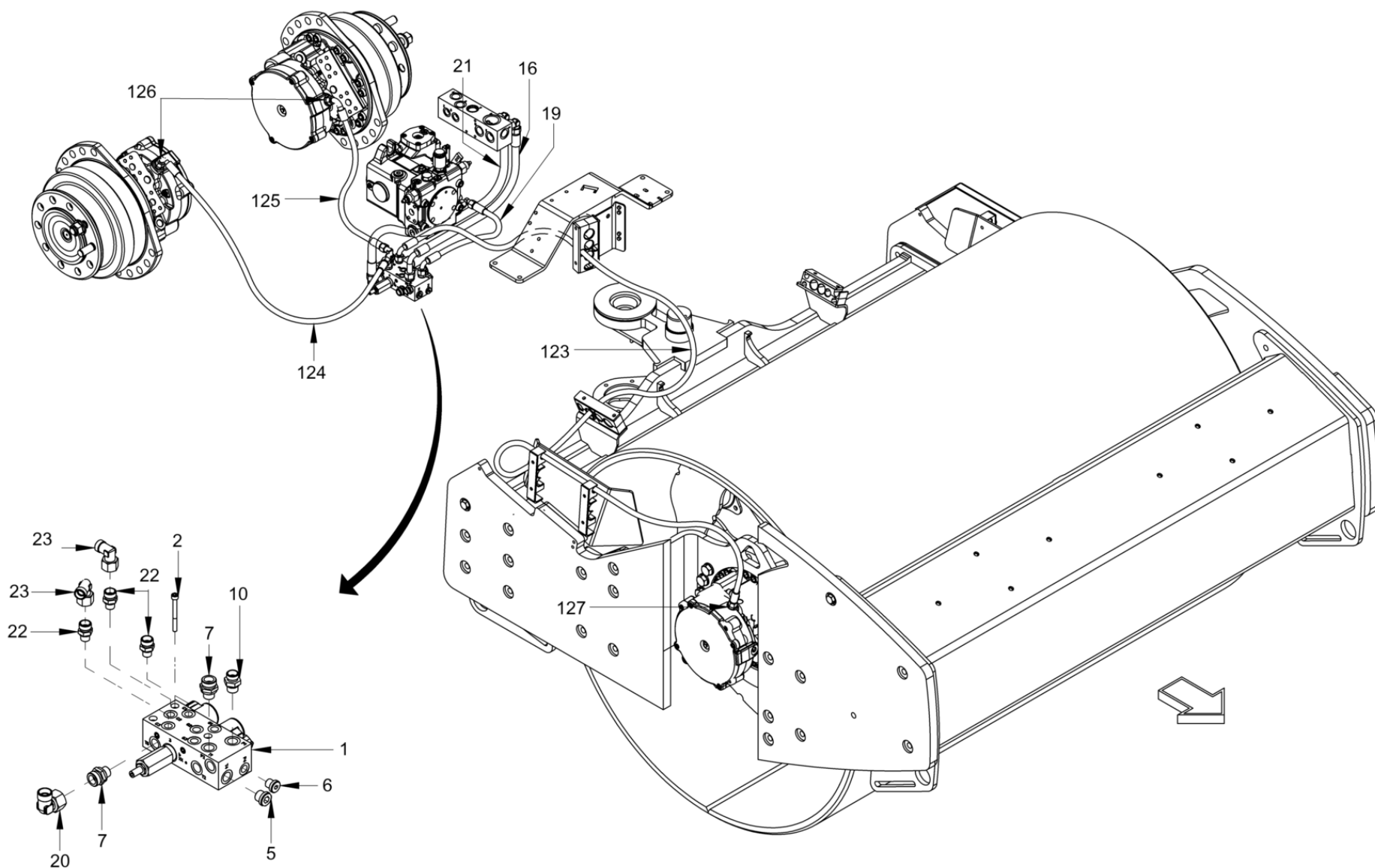

Idraulica freni
Freno hidráulico
Brake hydraulics

Item	Item no.	Descrizione	Descripción	Description	Information	Pc.	Unit
1	5100023341	Blocco valvole	Bloque de válvula	Valve block		1	pc
2	5100022982	Vite a testa cilindrica	Tornillo cilíndrico	Cheese-head screw		3	pc
5	5100011855	Tappo a vite	Tornillo de cierre	Screw plug		1	pc
6	5100011608	Tappo a vite	Tornillo de cierre	Screw plug		1	pc
7	5100013603	Pres a vite diritta	Racor para enroscar recto	Straight screwed socket		2	pc
10	5100011855	Tappo a vite	Tornillo de cierre	Screw plug		1	pc
16	5100023518	Tubo flessibile	Manguera	Hose		1	pc
19	5100070754	Tubo flessibile	Manguera	Hose		1	pc
20	5100013483	Connettore a gomito regolabile	Racor angular ajustable	Elbow adjustable		1	pc
21	5100023111	Tubo flessibile	Manguera	Hose		1	pc
22	5100013616	Pres a vite diritta	Racor para enroscar recto	Straight screwed socket		3	pc
23	5100013619	Connettore a gomito regolabile	Racor angular ajustable	Elbow adjustable		2	pc
123	5100070756	Tubo flessibile	Manguera	Hose		1	pc
123	5100070757	Tubo flessibile	Manguera	Hose		1	pc
124	5100022978	Tubo flessibile	Manguera	Hose		1	pc
124	5100023276	Tubo flessibile	Manguera	Hose		1	pc
125	5100023456	Tubo flessibile	Manguera	Hose		1	pc
126	5100013472	Pres a vite diritta	Racor para enroscar recto	Straight screwed socket		2	pc
127	5100013472	Pres a vite diritta	Racor para enroscar recto	Straight screwed socket		1	pc



Cambio velocità
Cambio de marchas
Gear shifting

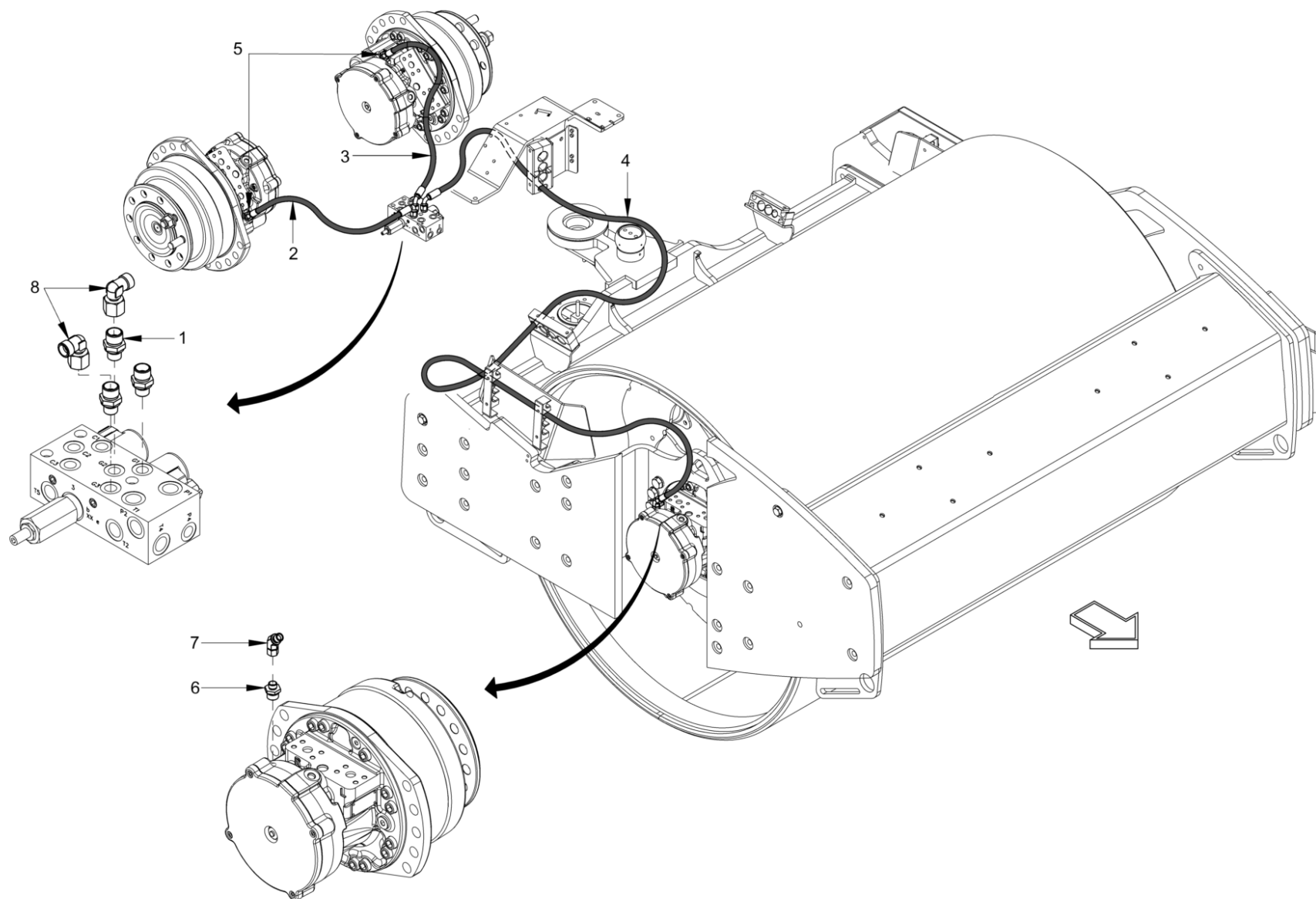

Cambio velocità
Cambio de marchas
Gear shifting

Item	Item no.	Descrizione	Descripción	Description	Information	Pc.	Unit
1	5100013474	Presa a vite diritta	Racor para enroscar recto	Straight screwed socket		3	pc
2	5100023171	Tubo flessibile	Manguera	Hose		1	pc
2	5100070758	Tubo flessibile	Manguera	Hose		1	pc
3	5100023000	Tubo flessibile	Manguera	Hose		1	pc
3	5100023016	Tubo flessibile	Manguera	Hose		1	pc
4	5100070759	Tubo flessibile	Manguera	Hose		1	pc
4	5100070761	Tubo flessibile	Manguera	Hose		1	pc
5	5100022876	Presa a vite diritta	Racor para enroscar recto	Straight screwed socket		2	pc
5	5100022935	Presa a vite diritta	Racor para enroscar recto	Straight screwed socket		2	pc
6	5100022876	Presa a vite diritta	Racor para enroscar recto	Straight screwed socket		1	pc
7	5100012072	Connettore a gomito regolabile	Racor angular ajustable	Elbow adjustable		1	pc
8	5100013482	Connettore a gomito regolabile	Racor angular ajustable	Elbow adjustable		1	pc
8	5100013482	Connettore a gomito regolabile	Racor angular ajustable	Elbow adjustable		2	pc



Braccio oscillante-snodabile
Articulación central
Centre pivot assembly

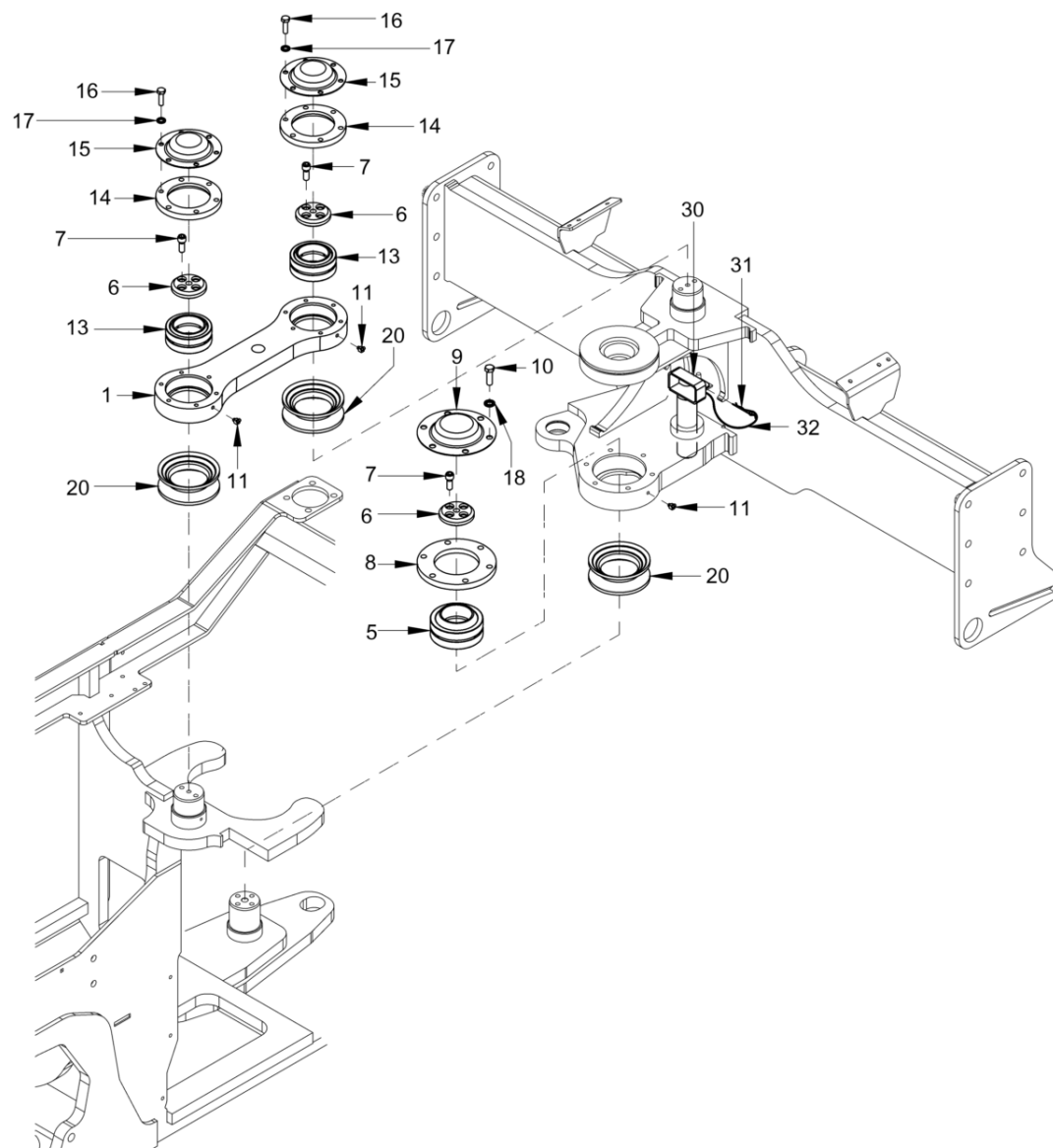

Braccio oscillante-snodabile
Articulación central
Centre pivot assembly

Item	Item no.	Descrizione	Descripción	Description	Information	Pc.	Unit
1	5100025965	Lamiera	Chapa	Metal plate		1	pc
5	5100023017	Cuscinetto radiale a sfere	Cojinete articulación radial	Radial rod end bearing		1	pc
6	5100023074	Lamiera	Chapa	Metal plate		3	pc
7	5100022852	Vite a testa cilindrica	Tornillo cilíndrico	Cheese-head screw		8	pc
8	5100023082	Lamiera	Chapa	Metal plate		1	pc
9	5100023091	Coperchio	Tapa	Lid		1	pc
10	5100022849	Bullone esagonale	Tornillo hexagonal	Hexagon screw		6	pc
11	5100012480	Punto d'ingrassaggio	Engrasador	Greasing nipple		3	pc
13	5100022924	Snodo sferico	Cojinete articulado	Rod end ball joint		2	pc
14	5100023081	Flangia	Brida	Flange		2	pc
15	5100023083	Coperchio	Tapa	Lid		2	pc
16	5100013416	Bullone esagonale	Tornillo hexagonal	Hexagon screw		12	pc
17	5100012967	Rondella di sicurezza	Disco de seguridad	Locking washer		12	pc
18	5100012968	Rondella di sicurezza	Disco de seguridad	Locking washer		6	pc
20	5100023080	Guarnizione	Anillo de junta	Sealing ring		3	pc
30	5100022976	Perno	Bulón	Bolt		1	pc
31	5100023036	Coppiglia a molla	Pasador de horquilla	W-clip		1	pc
32	5100011590	Fune di sicurezza	Cordón de seguridad	Safety cord		1	pc



Sistema sterzante
Dirección
Steering

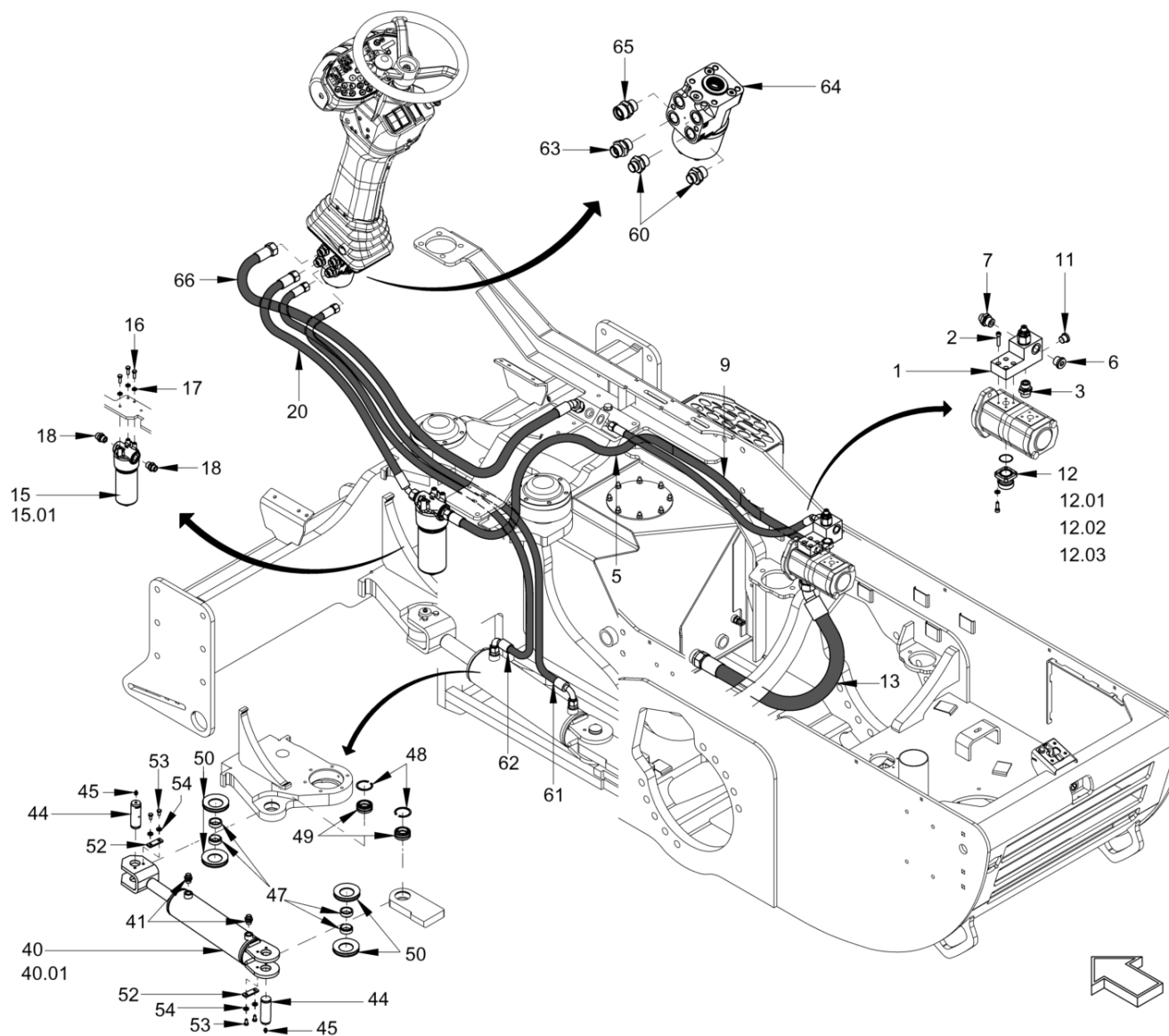

Sistema sterzante
Dirección
Steering

Item	Item no.	Descrizione	Descripción	Description	Information	Pc.	Unit
1	5100023106	Blocco valvole	Bloque de válvula	Valve block		1	pc
2	5100011481	Vite a testa cilindrica	Tornillo cilíndrico	Cheese-head screw		4	pc
3	5100013476	Presa a vite dritta	Racor para enroscar recto	Straight screwed socket		1	pc
5	5100070762	Tubo flessibile	Manguera	Hose		1	pc
6	5100011665	Tappo a vite	Tornillo de cierre	Screw plug		1	pc
7	5100013433	Presa a vite dritta	Racor para enroscar recto	Straight screwed socket		1	pc
9	5100023590	Tubo flessibile	Manguera	Hose		1	pc
11	5100011855	Tappo a vite	Tornillo de cierre	Screw plug		1	pc
12	5100011500	Anello a o	Anillo toroidal	O-ring seal	12.03	1	pc
12	5100012723	Vite a testa cilindrica	Tornillo cilíndrico	Cheese-head screw	12.01	4	pc
12	5100012937	Rondella	Arandela	Washer	12.02	4	pc
12	5100023115	Connessione a vite flangiata dritta	Racor de brida recto	Straight flange joint		1	pc
13	5100023458	Tubo flessibile	Manguera	Hose		1	pc
15	5100063875	Filtro a pressione	Filtro de presión	Pressure filter		1	pc
15	5100063876	Dispositivo di filtraggio	Cartucho de filtro	Filter insert	15.01	1	pc
16	5100012613	Bullone esagonale	Tornillo hexagonale	Hexagon screw		3	pc
17	5100012966	Rondella di sicurezza	Disco de seguridad	Locking washer		3	pc
18	5100012190	Presa a vite dritta	Racor para enroscar recto	Straight screwed socket		2	pc
20	5100023446	Tubo flessibile	Manguera	Hose		1	pc
40	5100023108	Kit di tenuta	Kit de juntas	Set of seals	40.01	1	pc
40	5100026006	Cilindro sterzante	Cilindro de dirección	Steering cylinder		1	pc
41	5100022945	Presa a vite dritta	Racor para enroscar recto	Straight screwed socket		2	pc
44	5100023223	Perno	Bulón	Bolt		2	pc
45	5100022845	Punto d'ingrassaggio	Engrasador	Greasing nipple		2	pc
47	5100023284	Anello distanziatore	Casquillo distanciator	Distance ring		4	pc
48	5100022860	Anello di sicurezza	Anillo fijador	Circlip		2	pc
49	5100022927	Cuscinetto radiale a sfere	Cojinete articulación radial	Radial rod end bearing		2	pc
50	5100011761	Guarnizione	Anillo de junta	Sealing ring		4	pc
52	5100023169	Lamiera	Chapa	Metal plate		2	pc
53	5100012515	Bullone esagonale	Tornillo hexagonale	Hexagon screw		4	pc
54	5100012966	Rondella di sicurezza	Disco de seguridad	Locking washer		4	pc
60	5100013433	Presa a vite dritta	Racor para enroscar recto	Straight screwed socket		2	pc
61	5100023408	Tubo flessibile	Manguera	Hose		1	pc
62	5100070763	Tubo flessibile	Manguera	Hose		1	pc
63	5100013476	Presa a vite dritta	Racor para enroscar recto	Straight screwed socket		1	pc
64	5100070764	Unità di guida	Unidad de dirección	Steering unit		1	pc



Sistema sterzante
 Dirección
 Steering

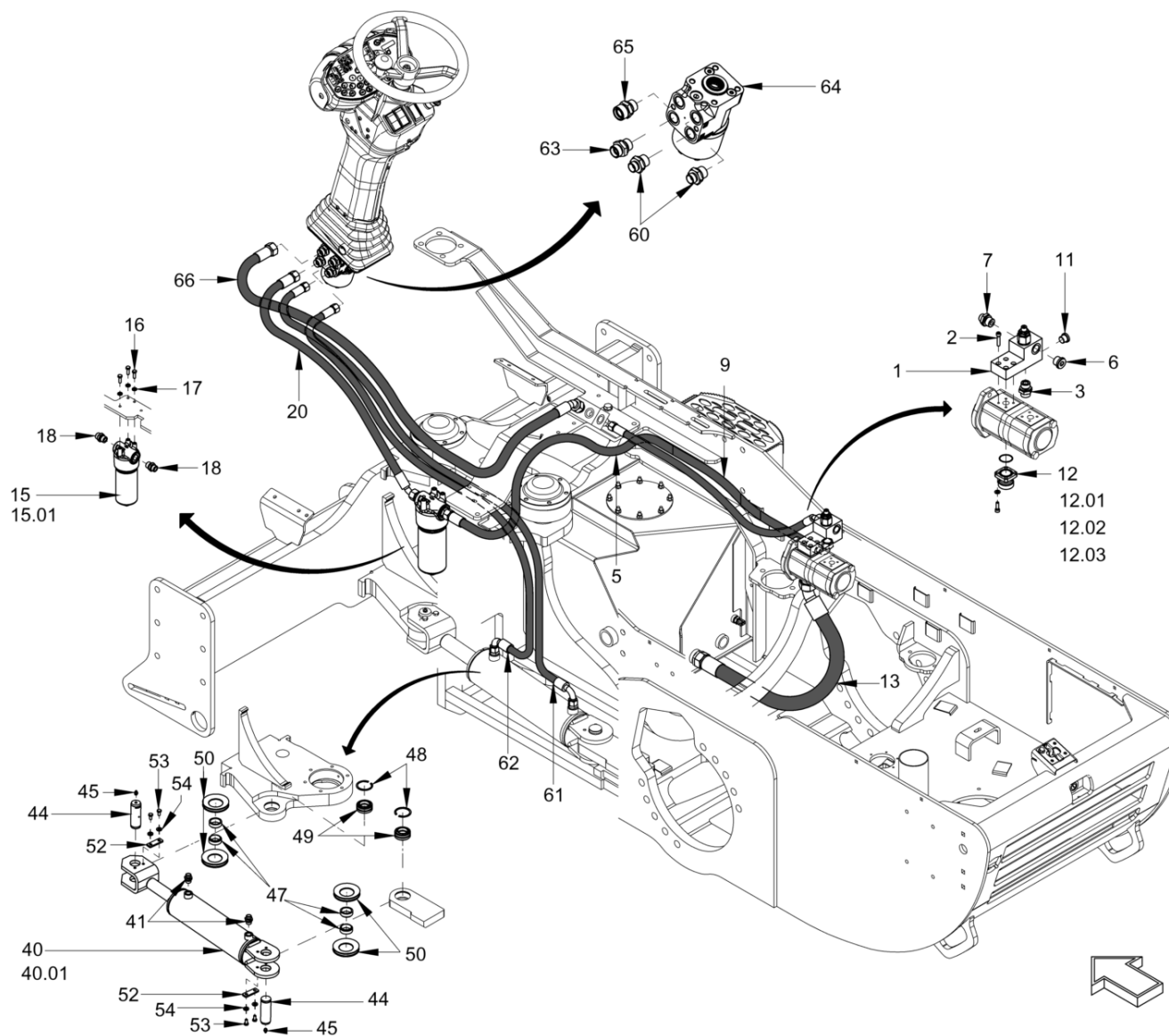

Sistema sterzante
Dirección
Steering

Item	Item no.	Descrizione	Descripción	Description	Information	Pc.	Unit
65	5100013477	Pres a vite diritta	Racor para enroscar recto	Straight screwed socket		1	pc
66	5100023447	Tubo flessibile	Manguera	Hose		1	pc



Fascia
Bandaje
Roller drum

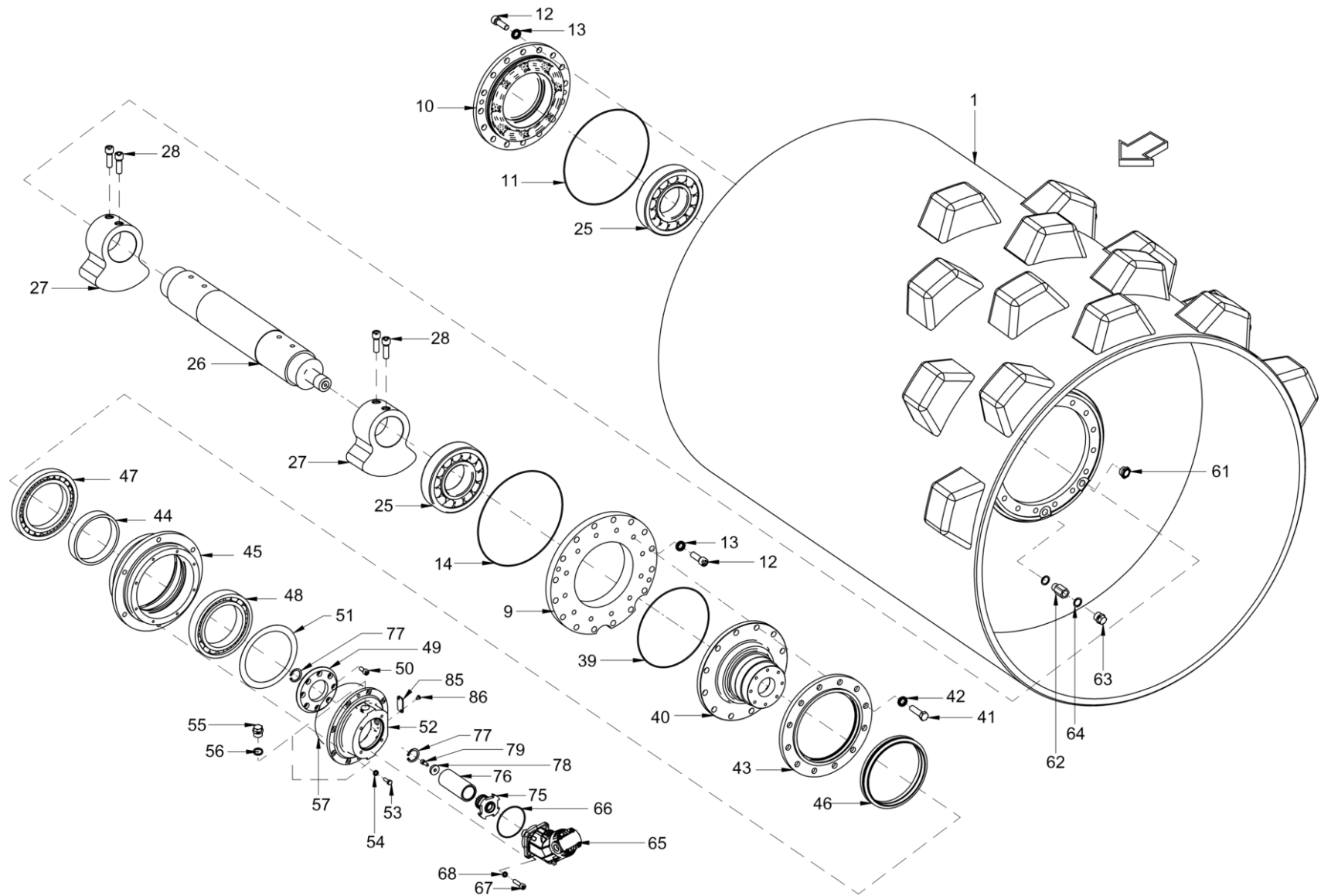

**Fascia
Bandaje
Roller drum**

Item	Item no.	Descrizione	Descripción	Description	Information	Pc.	Unit
1	5100025907	Rullo	Bandaje	Roller drum		1	pc
1	5100025916	Rullo	Bandaje	Roller drum		1	pc
9	5100022956	Flangia	Brida	Flange		1	pc
10	5100022955	Coperchio	Tapa	Lid		1	pc
11	5100022883	Anello a o	Anillo toroïdal	O-ring seal		1	pc
12	5100023174	Vite a testa cilindrica	Tornillo cilíndrico	Cheese-head screw		32	pc
13	5100012969	Rondella di sicurezza	Disco de seguridad	Locking washer		32	pc
14	5100022875	Anello a o	Anillo toroïdal	O-ring seal		1	pc
25	5100022907	Cuscinetti a rulli cilindrici	Rodamiento de rodillos cilínd.	Cylindrical roller bearing		2	pc
26	5100023090	Albero sbilanciato	Árbol desequilibrado	Unbalance shaft		1	pc
27	5100023454	Squilibrio	Desequilibrio	Unbalance		2	pc
28	5100023048	Vite a testa cilindrica	Tornillo cilíndrico	Cheese-head screw		4	pc
39	5100022937	Anello a o	Anillo toroïdal	O-ring seal		1	pc
40	5100023089	Flangia conica	Brida cónica	Cone flange		1	pc
41	5100022918	Vite a testa cilindrica	Tornillo cilíndrico	Cheese-head screw		12	pc
42	5100012969	Rondella di sicurezza	Disco de seguridad	Locking washer		12	pc
43	5100048709	Anello	Anillo	Ring		1	pc
44	5100022959	Anello	Anillo	Ring		1	pc
45	5100048708	Cuscinetto flangiato	Cojinete de la brida	Flanged bearing		1	pc
46	5100047247	Guarnizione ad anello scorrevole	Junta deslizante	Axial face seal		1	pc
47	5100022879	Cuscinetto radiale rigido a sfere	Rodamiento radial rígido	Grooved ball bearing		1	pc
48	5100022929	Cuscinetto radiale rigido a sfere	Rodamiento radial rígido	Grooved ball bearing		1	pc
49	5100022958	Coperchio	Tapa	Lid		1	pc
50	5100023172	Vite a testa cilindrica	Tornillo cilíndrico	Cheese-head screw		8	pc
51	5100023002	Rondella	Arandela de ajuste	Spacer shim		1	pc
52	5100023087	Flangia	Brida	Flange		1	pc
53	5100012519	Bullone esagonale	Tornillo hexagonal	Hexagon screw		8	pc
54	5100012966	Rondella di sicurezza	Disco de seguridad	Locking washer		8	pc
55	5100022828	Vite di bloccaggio	Tornillo de cierre	Locking screw		2	pc
56	5100022863	Guarnizione	Anillo de junta	Sealing ring		2	pc
57	5100013423	Anello a o	Anillo toroïdal	O-ring seal		1	pc
61	5100013388	Vetrino d'ispezione	Mirilla	Inspection glass		1	pc
62	5100023026	Connettore di riduzione	Racor reductor	Reducing piece		1	pc
63	5100022939	Vite di bloccaggio	Tornillo de cierre	Locking screw		1	pc
64	5100013005	Guarnizione	Anillo de junta	Sealing ring		2	pc
65	5100023397	Motore costante	Motor de volumen constante	Constant motor		1	pc

Fascia
Bandaje
Roller drum

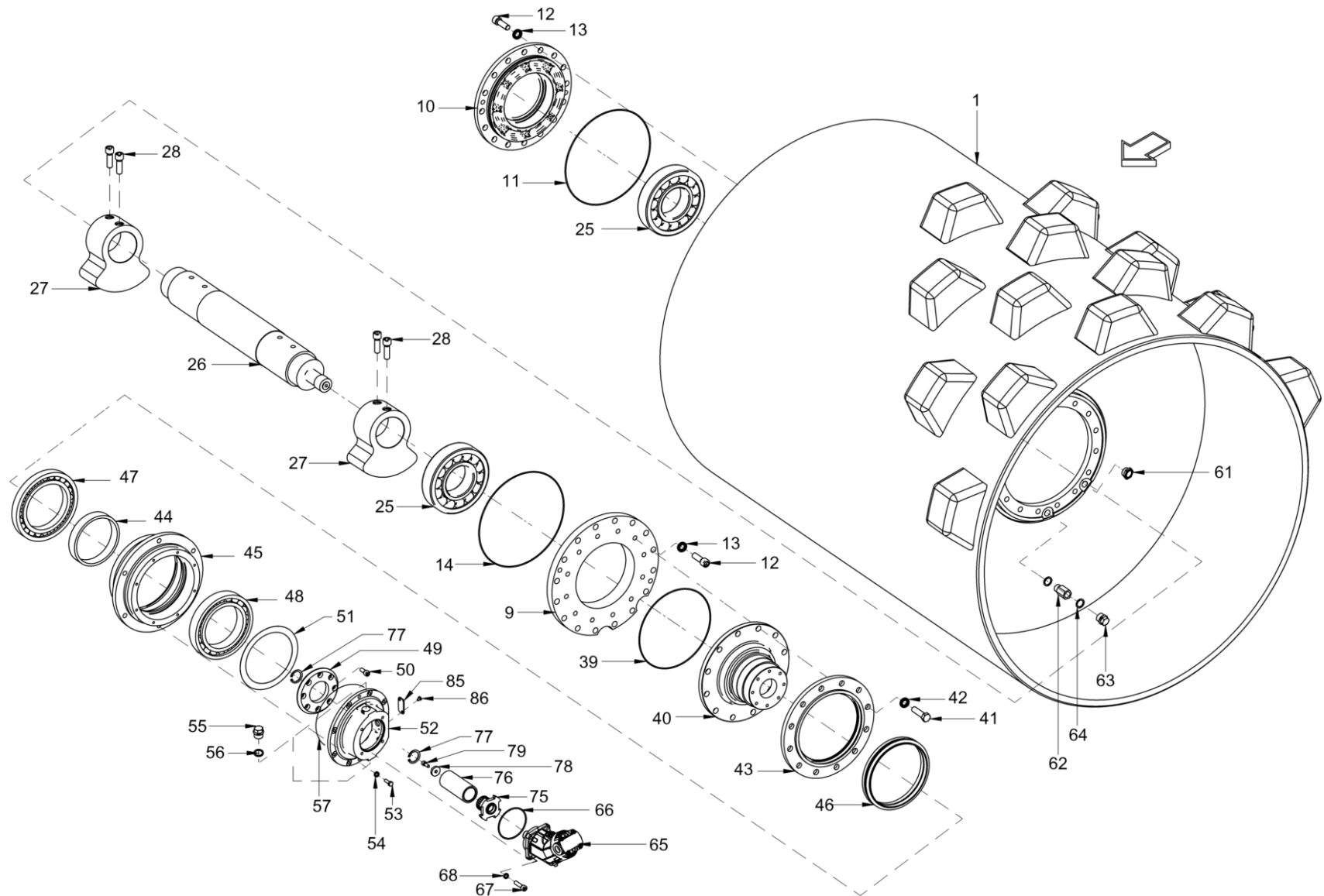

**Fascia
Bandaje
Roller drum**

Item	Item no.	Descrizione	Descripción	Description	Information	Pc.	Unit
66	5100022874	Anello a o	Anillo toroïdal	O-ring seal		1	pc
67	5100012508	Vite a testa cilindrica	Tornillo cilíndrico	Cheese-head screw		4	pc
68	5100012966	Rondella di sicurezza	Disco de seguridad	Locking washer		4	pc
75	5100025874	Boccola dentata	Casquillo dentado	Spline bush		1	pc
76	5100022954	Boccola dentata	Casquillo dentado	Spline bush		1	pc
77	5100022862	Anello di sicurezza	Anillo fijador	Circlip		2	pc
78	5100023079	Rondella	Arandela	Washer		1	pc
79	5100013455	Vite a testa cilindrica	Tornillo cilíndrico	Cheese-head screw		1	pc
85	5100023070	Coperchio	Chapa de recubrimiento	Cover sheet		1	pc
86	5100023194	Bullone esagonale	Tornillo hexagonal	Hexagon screw		2	pc



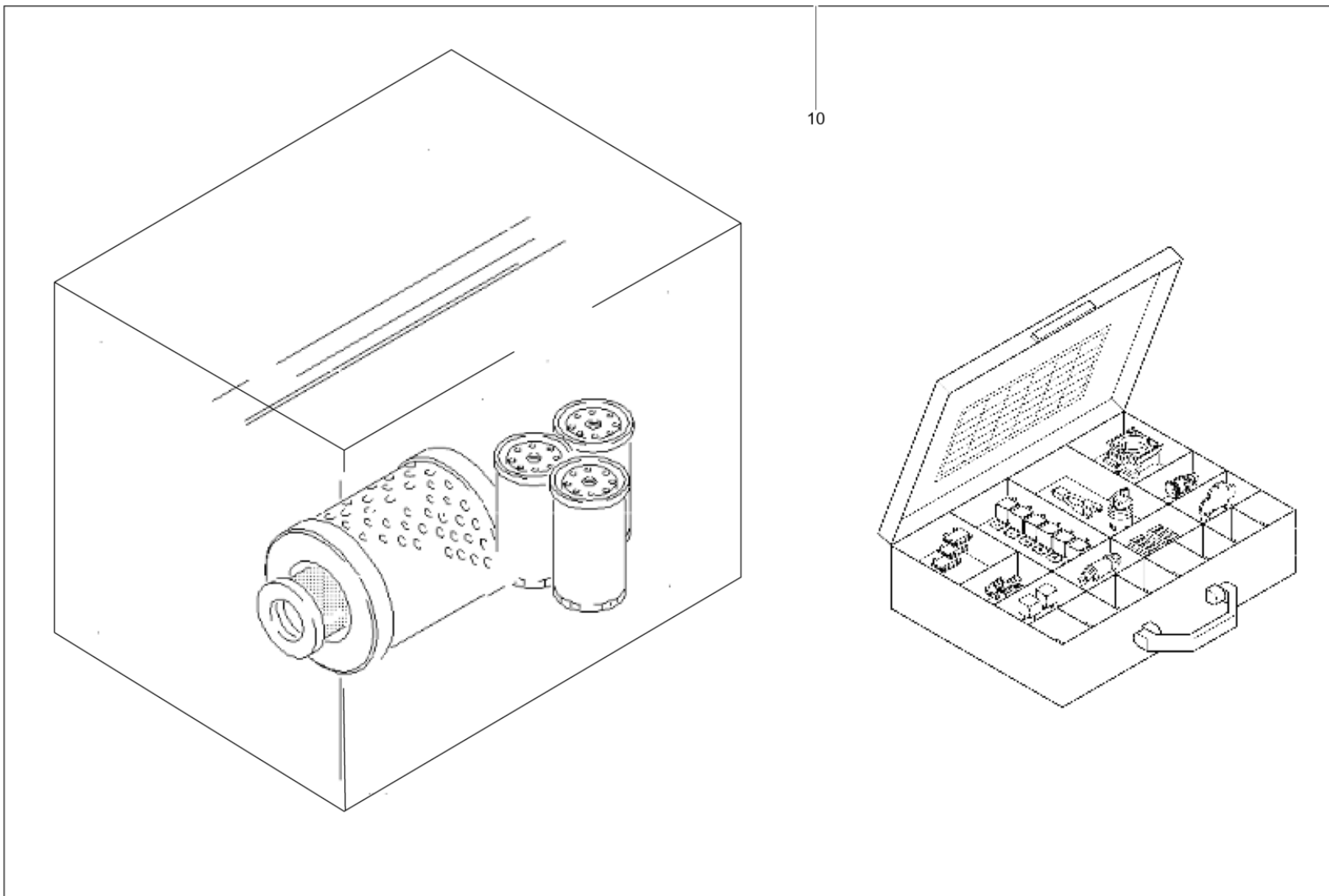

Kit di manutenzione e riparazione
Kits de mantenimiento y de reparación
Maintenance kits and repair kits

Item	Item no.	Descrizione	Descripción	Description	Information	Pc.	Unit
10	5100070770	Kit di manutenzione per 50 ore	Kit de mantenimiento 50 horas	Service kit at 50 hours		1	pc
10	5100070772	Kit di manutenzione ogni 500 ore	Kit de mantenimiento 500 horas	Service kit every 500 hours		1	pc
10	5100070773	Kit di manutenzione ogni 1000 ore	Kit de mantenimiento 1000horas	Service kit every 1000 hours		1	pc
10	5100070774	Kit di manutenzione ogni 2000 ore	Kit de mantenimiento 2000horas	Service kit every 2000 hours		1	pc



Nota
Observaciones
Note





**WACKER
NEUSON**

