



**WACKER  
NEUSON**

Ersatzteilkatalog  
Spare parts catalog  
Catálogo de piezas de repuesto  
Catalogue de pièces de rechange

**Innenvibrator  
Internal vibrator  
Vibrador interno  
Vibreur interne**

**IRFU45/230/15**



Type	IRFU45/230/15
Material Number	5100040886
Version	103
Language	de   en   es   fr



[www.wackerneuson.com](http://www.wackerneuson.com)

Copyright © 02.2024  
Wacker Neuson Produktion GmbH & Co. KG  
Printed in Germany.  
All rights reserved.

Ein Typenschild mit Typ, Artikelnummer, Version und Maschinen-Nummer ist an jedem Gerät angebracht. Die Daten von diesem Schild bitte notieren, damit sie auch bei Verlust oder Beschädigung des Schildes noch vorhanden sind. Der Typ, die Artikelnummer, die Versions-Nummer und die Maschinen-Nummer sind bei der Ersatzteilbestellung oder Nachfragen bezüglich Service-Informationen stets erforderlich.

Bei den in den Ersatzteillisten fettgedruckten Nummern handelt es sich um empfohlene Ersatzteile. Dies bedeutet, daß diese Teile bei normalen Anwendungsbedingungen natürlicher Abnutzung ausgesetzt sind und gelegentlich ersetzt oder überarbeitet werden müssen. Es wird geraten, diese Teile auf Lager bereit zu haben, um für Service-Arbeiten an diesem Gerät vorbereitet zu sein. Lagerbestände für diese und andere Teile, welche für ausgiebigere Reparaturarbeiten benötigt werden, können je nach Service-Gewohnheiten der einzelnen Kunden variieren.

Die Nummern meines Gerätes sind:

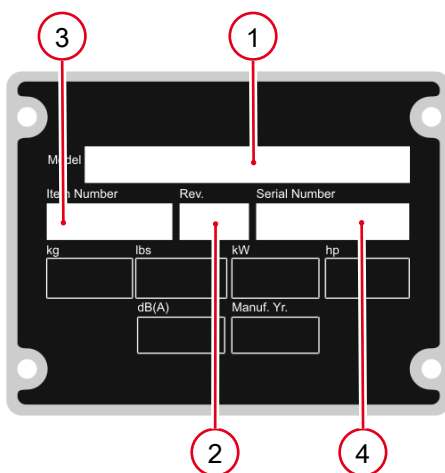

1. Typ
2. Version
3. Artikel-Nr.
4. Maschinen-Nr.

#### Umrechnungstabelle

Volumeneinheit	
1 ml	0.034 US fl.oz.
1 l	0.260 gal
Längeneinheit	
1 mm	0.039 in
1 m	3.280 ft
Gewicht	
1 kg	2.200 lbs
1 g	0.035 oz
Geschwindigkeit	
1 km/h	0.620 mph
Drehmoment	
1 Nm	0.740 ft.lbs

A nameplate listing the Model Number, Item Number, Revision, and Serial Number is attached to each unit. Please record the information found on this plate so it will be available should the nameplate become lost or damaged. When ordering parts or requesting service information, you will always be asked to specify the model, item number, revision number, and serial number of the unit.

Part Numbers appearing in boldface type are recommended spare parts. This means that these parts are subject to wear under normal operating conditions and may require periodic service or replacement. It is recommended that these items be stocked to meet the expected service requirements of this model. Actual stocking quantities of these and other parts used in more extensive repairs will depend on the service practices of each customer.

My machine's numbers are:



1. Model
2. Revision
3. Item No.
4. Serial No.

**Conversion table**

Volume unit	
1 ml	0.034 US fl.oz.
1 l	0.260 gal
Unit of length	
1 mm	0.039 in
1 m	3.280 ft
Weight	
1 kg	2.200 lbs
1 g	0.035 oz
Speed	
1 km/h	0.620 mph
Torque	
1 Nm	0.740 ft.lbs

Una placa de identificación con el modelo, número de referencia, nivel de revisión y número de serie ha sido añadida en cada máquina. Favor de anotar los datos en la placa en caso de que la placa de identificación sea destruida o perdida. En todos los pedidos para repuestos necesita siempre el modelo, el número de referencia, el nivel de revisión y el número de serie de la máquina en cuestión.

Los números de partes en negritas en las Listas Ilustradas de Partes son los repuestos recomendados, esto quiere decir que estas partes se desgastarán bajo circunstancias de funcionamiento normales y pueden requerir servicio periódico o su reemplazo. Se recomienda que el cliente mantenga un abastecimiento adecuado de estas partes para poder satisfacer la demanda requerida por el servicio a la máquina. La cantidad de repuestos que el cliente necesitará para reparaciones dependerá de la póliza de servicio de cada cliente.

Los números de mi máquina son:

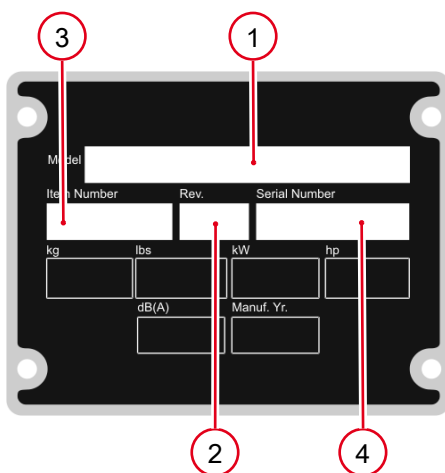

1. Modelo
2. Nivel de revisión
3. Número de referencia
4. Número de Serie

#### Tabla de conversión

Unidad de volumen	
1 ml	0.034 US fl.oz.
1 l	0.260 gal
Unidad de longitud	
1 mm	0.039 in
1 m	3.280 ft
Peso	
1 kg	2.200 lbs
1 g	0.035 oz
Velocidad	
1 km/h	0.620 mph
Par de apriete	
1 Nm	0.740 ft.lbs

Vibrationskörper Internal vibrator Cuerpo vibrador Vibrateur interrupteur .....	8
--	---

Schlauchanschluss Kpl. Hose connection cpl Conexión de manguera cpl. Connection tuyau cpl. ....	10
--	----

Zuleitungskabel MitPersonenschutz Power cable with bodyguard Cable de alimentación con interruptor de proteccióndiferencia Câble d'alimentation avecdes personnes .....	12
--	----

Zubehör  
Accessories  
Accesorios  
Accessoires

Handgriff Handle Empuñadura Poignée .....	14
--	----

Schultergurt Shoulder belt Correa Ruban .....	16
--	----



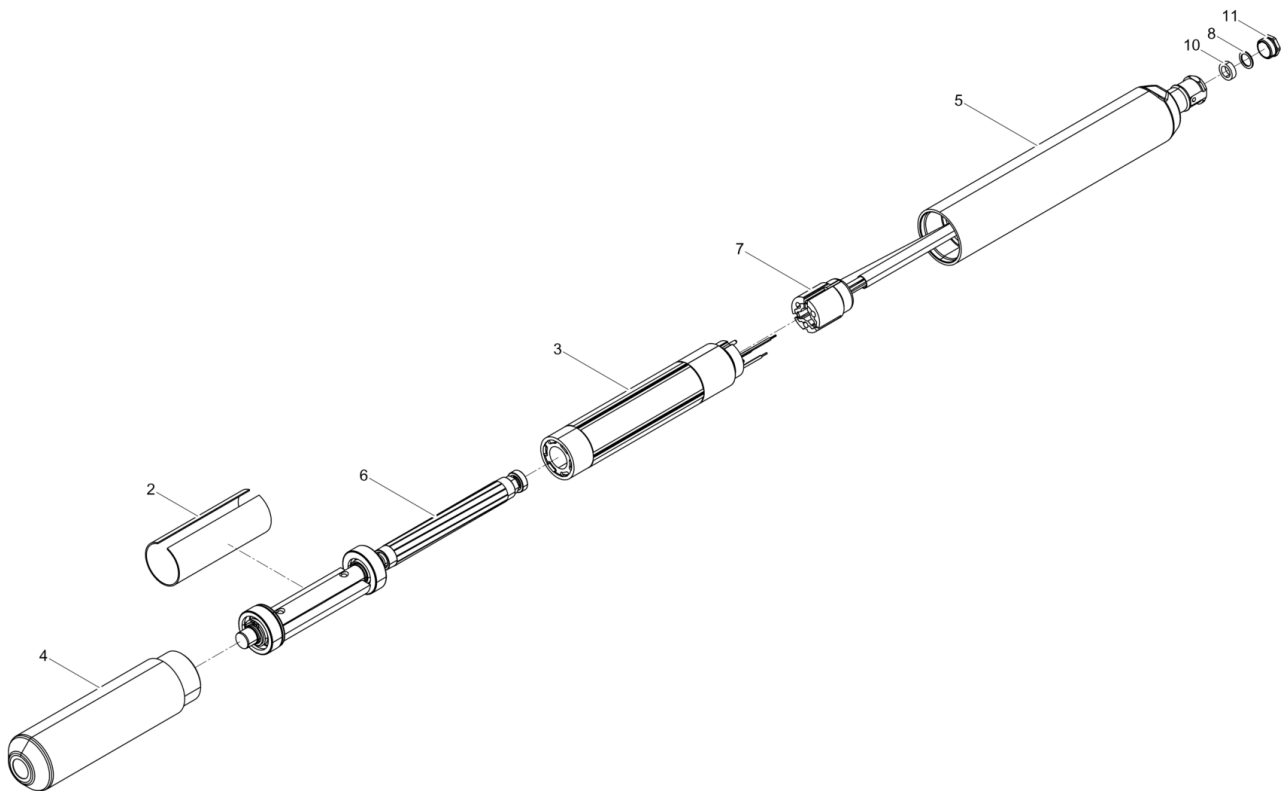



Pos. Item	Artikel Nr. Item no.	Pc.	Unit	Beschreibung Descripción	Description Description	Abm. Dim.	Norm Standard
						Drehmoment Torque	Schmierstoff Lubricant
2	5000106438	1	pc	Abstandshülse Manguito distanciador	Distance sleeve Douille d'écartement		
3	5000219476	1	pc	Stator Estator	Stator Stator		
4	5100006185	1	pc	Rohr-Unterteil Tubo inferior	Lower tube Chemise		
5	5000218502	1	pc	Rohr-Oberteil Tubo superior	Upper tube Chemise		
6	5100006186	1	pc	Motorläufer Kpl. Inducido del motor cpl.	Motor armature cpl. Rotor cpl.		
7	5100072285	1	pc	Elektroanschluss Conexión eléctrico	Electric connection Raccordement électrique		
8	5002003795	1	pc	Druckring Anillo de presión	Thrust ring Bague de pression	10 x 13,5 x 0,8	
10	5002003792	1	pc	Dichtring Anillo de junta	Gasket Bague d'étanchéité	9 x 13,5 x 5,5	
11	5002003793	1	pc	Druckschraube Tornillo de presión	Pressure screw Vis de pression		

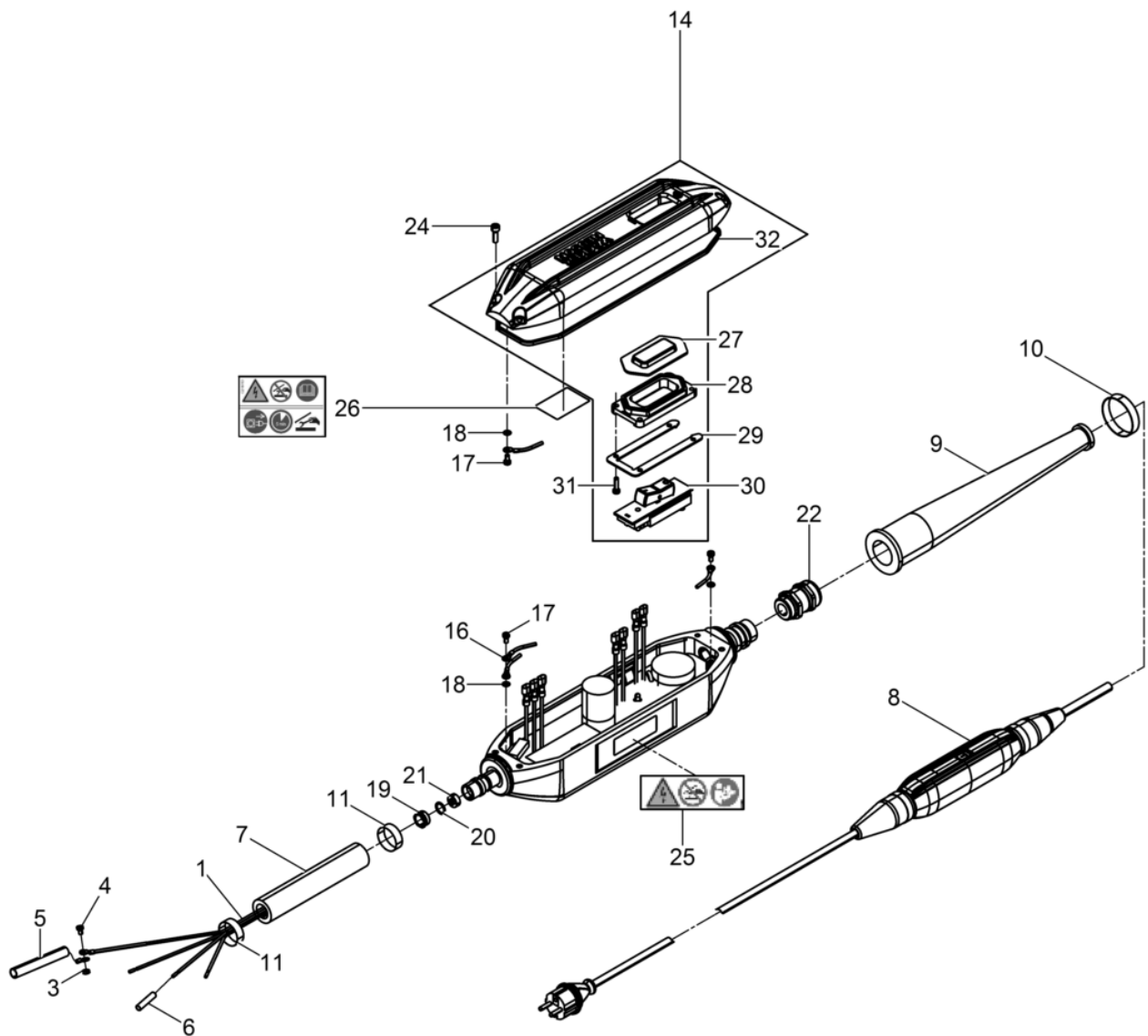

Pos. Item	Artikel Nr. Item no.	Pc.	Unit	Beschreibung Descripción	Description Description	Abm. Dim.	Norm Standard
						Drehmoment Torque	Schmierstoff Lubricant
1	5100072343	1	pc	Verbindungsleitung Kpl. Línea de conexión cpl.	Supply line cpl. Câble d'amenée cpl.		
3	5000013178	1	pc	Sechskantmutter Tuerca hexagonal	Hexagon nut Écrou hexagonal	M4	ISO4032
4	5000013171	1	pc	Zylinderschraube Tornillo cilíndrico	Cheese head screw Vis à tête cylindrique	M4 x 6 2.5Nm/2ft.lbs	ISO1207
5	5000125871	1	pc	Schrumpfschlauchstück Manguera de contracción	Shrink-fit hose Manchon thermorétractable		
6	5000202516	3	pc	Stoßverbinder Enchufe plano	Flat connector Connecteur rapide	1,1 - 2,6	
7	5100041246	1	pc	Schutzschlauch Manguera de protección	Protective hose Gaine de protection		
8	5100066679	1	pc	Zuleitungskabel Mit Personen- Schutz Cable de alimentación con	Power cable with personal protection Câble d'alimentation avec		
9	5003008468	1	pc	Gummitülle Casquillo de goma	Rubber funnel Paase fil en caoutchouc		
10	5002007121	1	pc	Schelle Abrazadera	Clamp Collier		
11	5000128141	2	pc	Schelle Vorg. Abrazadera	Clamp Collier		
14	5000211292	1	pc	Deckel Kpl. Tapa cpl.	Cover cpl. Couvercle cpl.		
16	5000208643	1	pc	Schutzleiter Toma a tierra	Ground wire Conducteur de sûreté		
17	5000011573	3	pc	Zylinderschraube Tornillo cilíndrico	Cheese head screw Vis à tête cylindrique	M4 x 8 2Nm/1ft.lbs	ISO4762
18	5000200988	3	pc	Zahnscheibe Arandela dentada	Toothed lock washer Rondelle à dents	A4,3	DIN6797
19	5000203577	1	pc	Druckschraube Tornillo de presión	Pressure screw Vis de pression	M16x1,5 12Nm/9ft.lbs	
20	5000203579	1	pc	Druckring Anillo de presión	Thrust ring Bague de pression	14x11x0,8	
21	5000202933	1	pc	Vierlochstopfen Tapón de cable 4 agujeros	4 hole plug Bouchon câble à 4 trous	M16x1,5	
22	5100030434	1	pc	Kabelverschraubung Atornilladura de cable	Screw connection Raccord à vis	12Nm/9ft.lbs	
24	5000219339	4	pc	Zylinderschraube Tornillo cilíndrico	Cheese head screw Vis à tête cylindrique	M 5x 14 5.5Nm/4ft.lbs	
25	5000219413	1	pc	Aufkleber Calcomanias	Labels Autocollants		
26	5000218763	1	pc	Aufkleber Calcomanias	Labels Autocollants		
27	5000129569	1	pc	Membran Diafragma	Diaphragm Diaphragme		
28	5000202103	1	pc	Flansch Brida	Flange Bride		
29	5000203024	1	pc	Flansch Brida	Flange Bride		
30	5000202101	1	pc	Geräteschalter Interruptor	Switch Interrupteur		
31	5000208645	4	pc	Zylinderschraube Tornillo cilíndrico	Cheese head screw Vis à tête cylindrique	M 4x 16	DIN7984
32	5000202542	1	pc	Dichtung Junta de estanqueidad	Gasket Garniture		

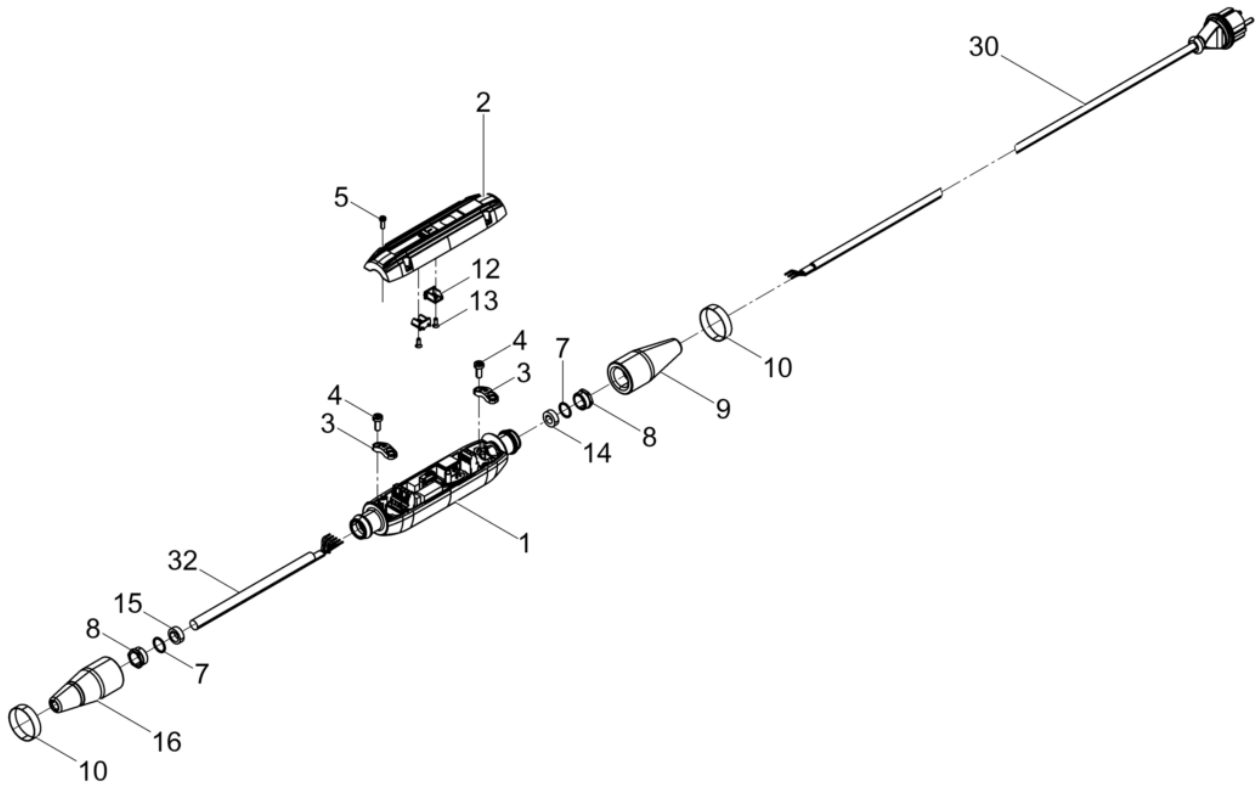

Pos. Item	Artikel Nr. Item no.	Pc.	Unit	Beschreibung Descripción	Description Description	Abm. Dim.	Norm Standard
						Drehmoment Torque	Schmierstoff Lubricant
1	5100036194	1	pc	Gehäuse Mit Elektronik Carcasa con electrónica	Housing with electronic Carter avec elektronik		
2	5100021620	1	pc	Deckel Mit LED Fenster Tapa	Cover with led window Couvercle		
3	5000106220	2	pc	Schelle Abrazadera	Clamp Collier		
4	5000108371	4	pc	Linsenkopfschraube Tornillo gota de sebo	Oval head screw Vis noyée lentiforme		
5	5000213543	4	pc	Linsenkopfschraube Tornillo gota de seboatado	Oval head screw Vis noyée lentiforme	4x12	
7	5000203578	2	pc	Druckring Anillo de presión	Thrust ring Bague de pression	18x15x0,8	
8	5000203576	2	pc	Druckschraube Tornillo de presión	Pressure screw Vis de pression	M20x1,5	
9	5100013971	1	pc	Kabeltülle Manguito	Cable bushing Passe câble		
10	5002007121	2	pc	Schelle Abrazadera	Clamp Collier		
12	5100018223	2	pc	Halter Soporte	Bracket Support		
13	5100019475	2	pc	Senkkopfschraube Tornillo avellanado	Countersunk screw Vis noyée	3,5 x 10	
14	5100045070	1	pc	Dichtstopfen Obturador	Sealing plug Bouchon d'étanchéité		
15	5100045071	1	pc	Dichtstopfen Obturador	Sealing plug Bouchon d'étanchéité		
16	5100046325	1	pc	Kabeltülle Manguito	Cable bushing Passe câble		
30	5100013860	1	pc	Zuleitung Mit Stecker Cable con enchufe	Power supply cable with plug Câble avec fiche		
32	5100066677	1	pc	Leitung Cable	Cable Câble		



Pos. Item	Artikel Nr. Item no.	Pc.	Unit	Beschreibung Descripción	Description Description	Abm. Dim.	Norm Standard
						Drehmoment Torque	Schmierstoff Lubricant
1	5100021505	1	pc	Handgriff Empuñadura	Handle Poignée		
3	5000222605	4	pc	Linsenkopfschraube Tornillo gota de seboatado	Oval head screw Vis noyée lentiforme	M 6 x 20	





Pos. Item	Artikel Nr. Item no.	Pc.	Unit	Beschreibung Descripción	Description Description	Abm. Dim.	Norm Standard
						Drehmoment Torque	Schmierstoff Lubricant
1	5100010882	1	pc	Schultergurt Correa	Shoulder belt Ruban		







**WACKER  
NEUSON**