



**WACKER  
NEUSON**

Ersatzteilkatalog  
Spare parts catalog  
Catálogo de piezas de repuesto  
Catalogue de pièces de rechange

**Generator  
Power  
Energía  
Puissance**

**GV7000A**

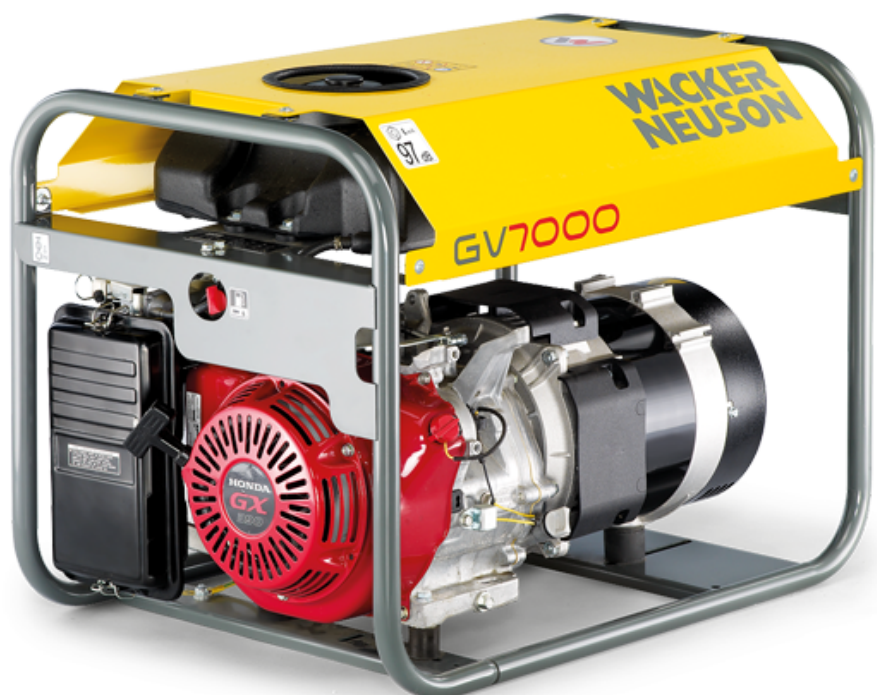

Type	GV7000A
Material Number	5000009348
Version	153
Language	de   en   es   fr



[www.wackerneuson.com](http://www.wackerneuson.com)

Copyright © 09.2022  
Wacker Neuson Produktion GmbH & Co. KG  
Printed in Germany.  
All rights reserved.

Ein Typenschild mit Typ, Artikelnummer, Version und Maschinen-Nummer ist an jedem Gerät angebracht. Die Daten von diesem Schild bitte notieren, damit sie auch bei Verlust oder Beschädigung des Schildes noch vorhanden sind. Der Typ, die Artikelnummer, die Versions-Nummer und die Maschinen-Nummer sind bei der Ersatzteilbestellung oder Nachfragen bezüglich Service-Informationen stets erforderlich.

Bei den in den Ersatzteillisten fettgedruckten Nummern handelt es sich um empfohlene Ersatzteile. Dies bedeutet, daß diese Teile bei normalen Anwendungsbedingungen natürlicher Abnutzung ausgesetzt sind und gelegentlich ersetzt oder überarbeitet werden müssen. Es wird geraten, diese Teile auf Lager bereit zu haben, um für Service-Arbeiten an diesem Gerät vorbereitet zu sein. Lagerbestände für diese und andere Teile, welche für ausgiebigere Reparaturarbeiten benötigt werden, können je nach Service-Gewohnheiten der einzelnen Kunden variieren.

Die Nummern meines Gerätes sind:



1. Typ
2. Version
3. Artikel-Nr.
4. Maschinen-Nr.

#### Umrechnungstabelle

Volumeneinheit	
1 ml	0.034 US fl.oz.
1 l	0.260 gal
Längeneinheit	
1 mm	0.039 in
1 m	3.280 ft
Gewicht	
1 kg	2.200 lbs
1 g	0.035 oz
Geschwindigkeit	
1 km/h	0.620 mph
Drehmoment	
1 Nm	0.740 ft.lbs

A nameplate listing the Model Number, Item Number, Revision, and Serial Number is attached to each unit. Please record the information found on this plate so it will be available should the nameplate become lost or damaged. When ordering parts or requesting service information, you will always be asked to specify the model, item number, revision number, and serial number of the unit.

Part Numbers appearing in boldface type are recommended spare parts. This means that these parts are subject to wear under normal operating conditions and may require periodic service or replacement. It is recommended that these items be stocked to meet the expected service requirements of this model. Actual stocking quantities of these and other parts used in more extensive repairs will depend on the service practices of each customer.

My machine's numbers are:



1. Model
2. Revision
3. Item No.
4. Serial No.

**Conversion table**

Volume unit	
1 ml	0.034 US fl.oz.
1 l	0.260 gal
Unit of length	
1 mm	0.039 in
1 m	3.280 ft
Weight	
1 kg	2.200 lbs
1 g	0.035 oz
Speed	
1 km/h	0.620 mph
Torque	
1 Nm	0.740 ft.lbs

Una placa de identificación con el modelo, número de referencia, nivel de revisión y número de serie ha sido añadida en cada máquina. Favor de anotar los datos en la placa en caso de que la placa de identificación sea destruida o perdida. En todos los pedidos para repuestos necesita siempre el modelo, el número de referencia, el nivel de revisión y el número de serie de la máquina en cuestión.

Los números de partes en negritas en las Listas Ilustradas de Partes son los repuestos recomendados, esto quiere decir que estas partes se desgastarán bajo circunstancias de funcionamiento normales y pueden requerir servicio periódico o su reemplazo. Se recomienda que el cliente mantenga un abastecimiento adecuado de estas partes para poder satisfacer la demanda requerida por el servicio a la máquina. La cantidad de repuestos que el cliente necesitará para reparaciones dependerá de la póliza de servicio de cada cliente.

Los números de mi máquina son:



1. Modelo
2. Nivel de revisión
3. Número de referencia
4. Número de Serie

#### Tabla de conversión

Unidad de volumen	
1 ml	0.034 US fl.oz.
1 l	0.260 gal
Unidad de longitud	
1 mm	0.039 in
1 m	3.280 ft
Peso	
1 kg	2.200 lbs
1 g	0.035 oz
Velocidad	
1 km/h	0.620 mph
Par de apriete	
1 Nm	0.740 ft.lbs

Une plaque signalétique mentionnant le modèle, le numéro de référence, le niveau de revision et le numéro de série est fixée sur chaque machine. Veuillez noter les informations relevées sur cette plaque de façon à ce qu'elles soient toujours disponibles si la plaque signalétique venait à être perdue ou endommagée. Lorsque vous commandez des pièces détachées ou vous sollicitez des informations après-vente, on vous demandera toujours de préciser le modèle, le numéro de référence, le niveau de revision et le numéro de série de la machine.

Les numéros de pièces imprimés en caractères gras dans les Listes des Pièces Détachées de ce manuel sont les pièces détachées recommandées par la Wacker. Cela veut dire que ces pièces sont sujettes à usure dans des conditions de travail normales et peuvent nécessiter de l'entretien ou leur remplacement. Nous recommandons que vous disposez d'un stock de ces pièces pour pouvoir satisfaire la demande d'entretien de cette machine. Le client doit décider lui-même de la quantité exacte de pièces de rechange qu'il disposera dans ses stocks.

Les numéros de ma machine sont :



1. Typ
2. Version
3. Artikel-Nr.
4. Maschinen-Nr.

**Table de conversion**

Unité de volume	
1 ml	0.034 US fl.oz.
1 l	0.260 gal
Unité de longueur	
1 mm	0.039 in
1 m	3.280 ft
Poids	
1 kg	2.200 lbs
1 g	0.035 oz
Vitesse	
1 km/h	0.620 mph
Couple de serrage	
1 Nm	0.740 ft.lbs

Rahmen Kpl. Frame cpl. Marco cpl. Châssis cpl. ....	10
--	----

Lichtmaschine Kpl. Alternator cpl. Alternador cpl. Alternateur cpl. ....	12
---	----

Motor Kpl. Motor cpl. Motor cpl. Moteur cpl. ....	14
--	----

Aufkleber Labels Calcomanias Autocollants .....	16
--	----

Motor  
Engine  
Motor  
Moteur

Seilzugstarter Starter Arrancador Démarreur .....	18
--	----

Gebläseabdeckung Fan hood Tapa de ventilador Couvercle du sys. de vent. ....	20
---	----

Vergaser Carburetor Carburador Carburateur .....	22
---	----

Luffilter Air cleaner Filtro del aire Filtre à air .....	24
---	----

Schwungrad Fly wheel Volante Volant .....	26
--	----

Zylinderkopf Cylinder head Culata Culasse .....	28
--	----

Zündspule Ignition coil Bobina de encendido Bobine d'allumage .....	30
--	----

Regler Governor Regulador Régulateur .....	32
---	----

Zylindergehäuse Cylinder housing Carcasa de cilindro Carter cylindre .....	34
---	----

Kurbelgehäuseabdeckung Crankcase cover Cubierta da la caja de manivel Couvercle carter de manivelle .....	36
--	----

Kurbelwelle Crankshaft Cigüeñal Vilebrequin .....	38
--	----

Kolben Piston Pistón Piston .....	40
--	----

Nockenwelle Camshaft Arbol de levas Arbre à cames .....	42
--	----

Aufkleber Label Calcomania Autocollant .....	44
---	----

Zubehör  
 Accessories  
 Accesorios  
 Accessoires

Führungswagen Kpl. Guiding trolley cpl. Carro guía cpl. Chariot guideur cpl. ....	46
--	----

Kranabhängung Kpl. Crane lifting eye cpl. Ojete de suspensión de grua cp Oeillet de suspension pour .....	48
--	----

Transportwagen Kpl. Cart transportation cpl. Carro transportación cpl. Voiturette transport cpl. ....	50
--	----





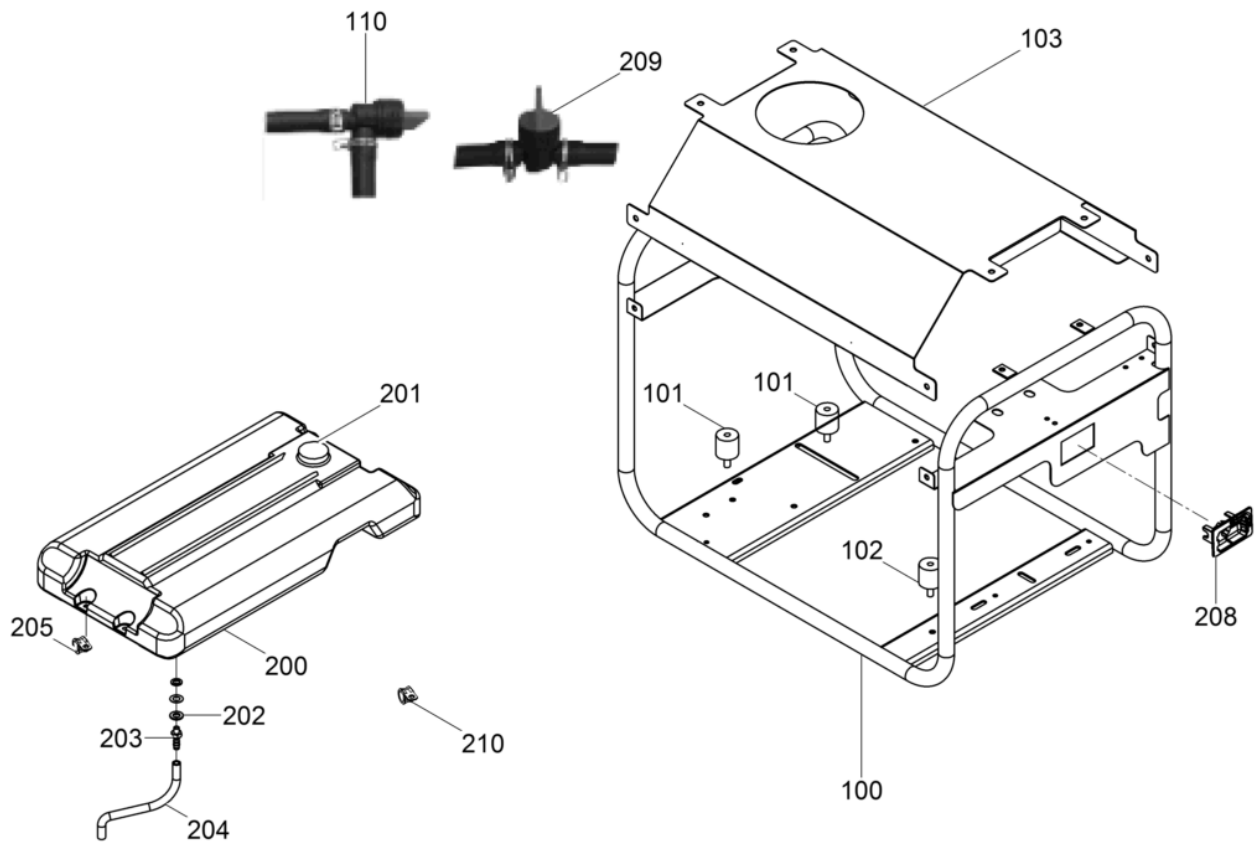

Pos. Item	Artikel Nr. Item no.	Pc.	Unit	Beschreibung Descripción	Description Description	Abm. Dim.	Norm Standard
						Drehmoment Torque	Schmierstoff Lubricant
100	5100036152	1	pc	Rahmen Kpl. Marco cpl.	Frame cpl. Châssis cpl.		
101	5000157407	2	pc	Puffer Amortiguador	Shockmount Silentbloc		
102	5000157406	1	pc	Puffer Amortiguador	Shockmount Silentbloc	M8 x 40 x 40mm OD	
103	5000186884	1	pc	Deckel Tapa	Cover Couvercle		
110	5000160412	1	pc	Kraftstoffhahn Llave de combustible	Fuel cock Robinet d'essence		
200	5100053650	1	pc	Kraftstofftank Tanque de combustible	Fuel tank Réservoir de carburant		
201	5000175835	1	pc	Tankdeckel Tapa de tanque	Tank cap Couvercle du reservoir		
202	5000163040	1	pc	Scheibe Arandela	Washer Rondelle		
203	5000163041	1	pc	Stutzen Manguito	Muff Manchon		
204	5000163042	1	pc	Kraftstoffleitung Tubería de combustible	Fuel pipe Tuyau à combustible		
205	5000163039	1	pc	Schelle Abrazaderaustible	Clamp Agrafe		
208	5100002960	1	pc	Halterung Soporte	Bracket Équerre		
209	5100042109	1	pc	Kraftstoffhahn Llave de combustible	Fuel cock Robinet d'essence		
210	5100053309	1	pc	Schelle Abrazadera	Clamp Agrafe		

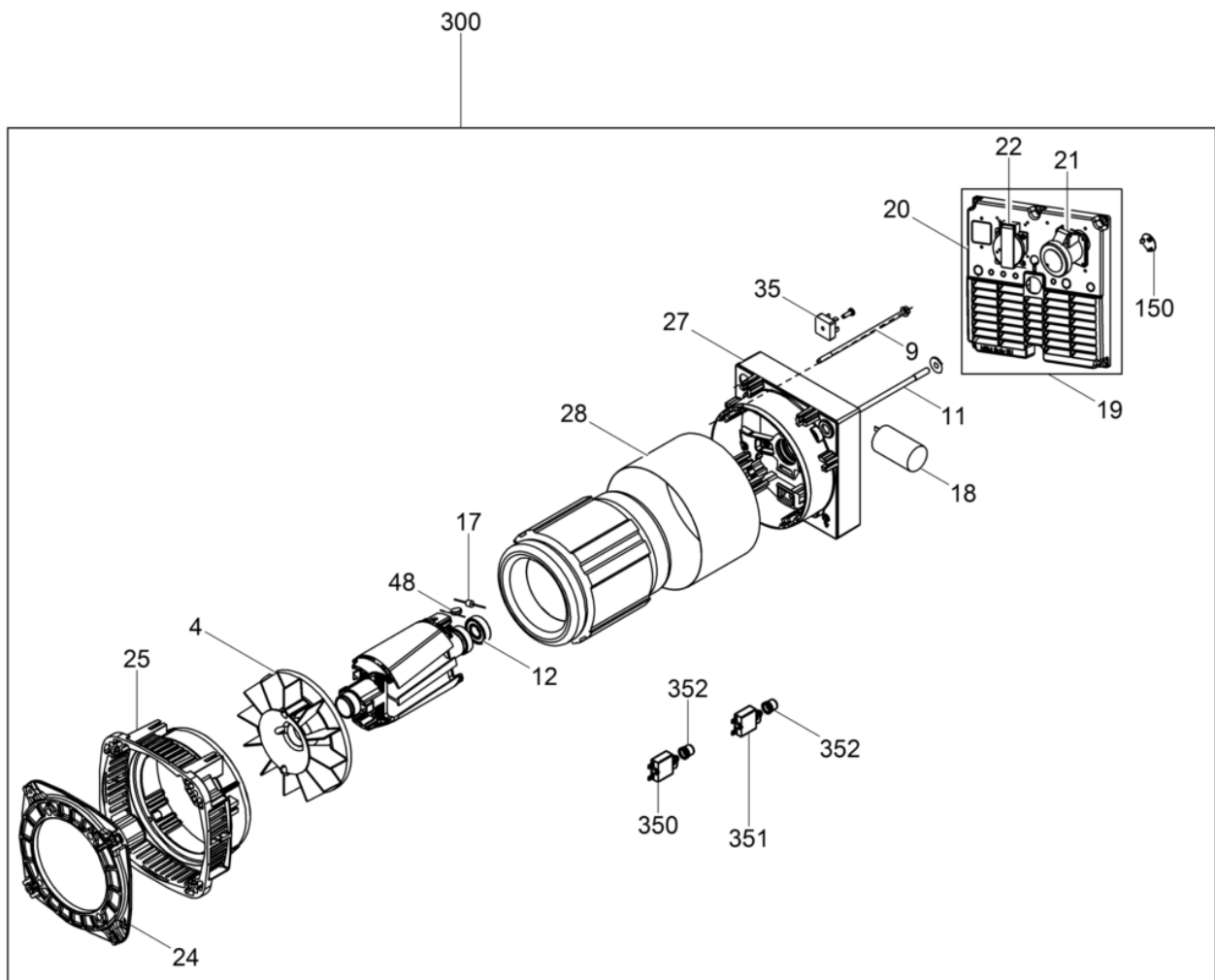

Pos. Item	Artikel Nr. Item no.	Pc.	Unit	Beschreibung Descripción	Description Description	Abm. Dim.	Norm Standard
						Drehmoment Torque	Schmierstoff Lubricant
4	5000160495	1	pc	Gebläserad Ventilador	Fan wheel Roue d'aeration		
9	5100003014	4	pc	Schraube Tornillo	Screw Vis		
11	5100003015	1	pc	Schraube Tornillo	Screw Vis		
12	5000192513	1	pc	Lager Cojinete	Bearing Palier		
17	5000157415	1	pc	Diode Diodo	Diode Diode		
18	5000157468	1	pc	Kondensator Condensador	Capacitor Condensateur		
19	5100003016	1	pc	Deckel Kpl. Tapa cpl.	Cover cpl. Couvercle cpl.		
20	5000157438	1	pc	Deckel Tapa	Cover Couvercle		
21	5200002504	1	pc	Steckdose Tomacorriente	Receptacle (socket) Prise de courant		
22	5000156665	1	pc	Steckdose Schuko Enchufe schuko	Socket schuko Prise schuko	250V/16A/2P+T/3 8x38	
24	5000192515	1	pc	Adapterplatte Placa del adaptador	Adapter plate Plaque d'adaptateur		
25	5100003069	1	pc	Gehäuse Carcasa	Housing Carter		
27	5000192518	1	pc	Zwischenplatte Placa intermedia	Intermediary plate Plaque intermediaire		
28	5100002998	1	pc	Gehäuseband Cinta	Band Ruban		
35	5000192520	1	pc	Gleichrichter 4-Polig Rectificador	Rectifier Redresseur		
48	5000192521	1	pc	Varistor Varistor	Varistor Varistor		
150	5000192538	1	pc	Stopfen Tapón	Plug Bouchon		
300	5100002928	1	pc	Lichtmaschine Kpl. Alternador cpl.	Alternator cpl. Alternateur cpl.		
350	5000157452	1	pc	Thermoschutzschalter Interruptor de protección	Protective switch Interrupteur de protection	25A	
351	5000182881	1	pc	Thermoschutzschalter Interruptor de protección	Protective switch Interrupteur de protection	15A	
352	5000156732	2	pc	Schutzdeckel Tapa de protección	Protective cover Couvercle de protection		

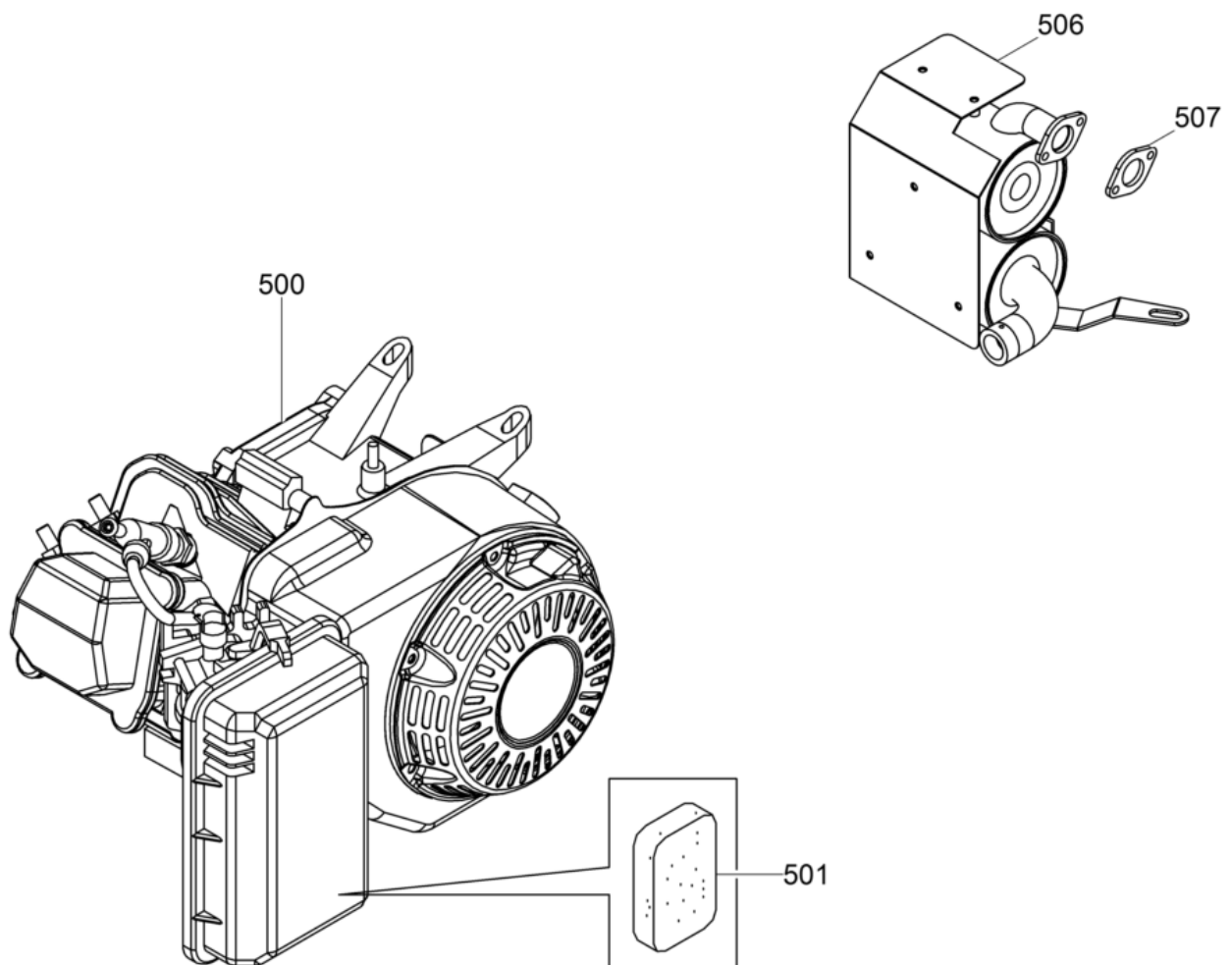

Pos. Item	Artikel Nr. Item no.	Pc.	Unit	Beschreibung Descripción	Description Description	Abm. Dim.	Norm Standard
						Drehmoment Torque	Schmierstoff Lubricant
500	5100050243	1	pc	Benzinmotor Motor a gasolina	Gas engine Moteur à essence		
501	5000158502	1	pc	Filtereinsatz Cartucho filtrante	Filter insert Element filtrant		
506	5000157694	1	pc	Auspuff Escape	Exhaust Échappement		
507	5000162672	1	pc	Auspuffdichtung Empaquetadura	Exhaust seal Joint de silencieux		

WACKER  
NEUSON

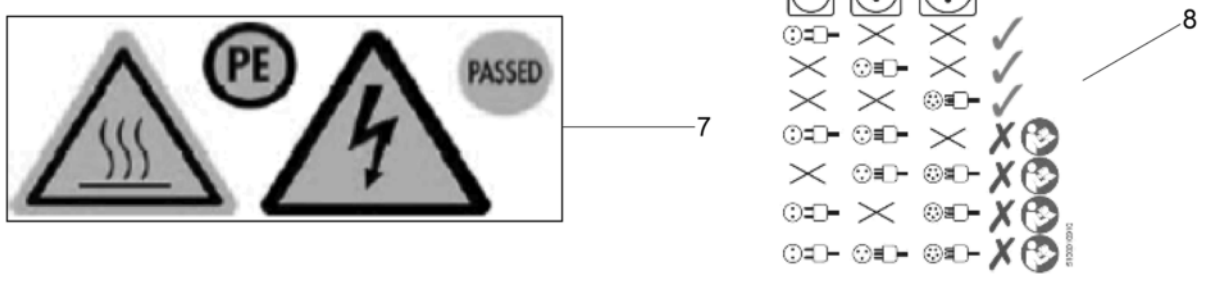



Pos. Item	Artikel Nr. Item no.	Pc.	Unit	Beschreibung Descripción	Description Description	Abm. Dim.	Norm Standard
						Drehmoment Torque	Schmierstoff Lubricant
1	5000222103	1	pc	Aufkleber Logo Calcomania insignia	Label logo Autocollant logo	80 mm	
2	5000222086	1	pc	Aufkleber Symbol Calcomania simbololo	Label symbol Autocollant symbole		
3	5000177729	1	pc	Aufkleber GV7000 Calcomania gv7000	Label gv7000 Autocollant gv7000	27	
4	5100069592	1	pc	Aufkleber Schalleistungspegel 97Db Etiqueta -nivel de potenciaacústica 97db	Decal-sound power level 97db Autocollante-niveau sonore		
5	5000186876	1	pc	Aufkleber Calcomania	Label Autocollant		
6	5000186878	1	pc	Aufkleber Calcomania	Label Autocollant		
7	5000186880	1	pc	Aufkleber Calcomania	Label Autocollant		
8	5100010910	1	pc	Aufkleber Calcomania	Label Autocollant		

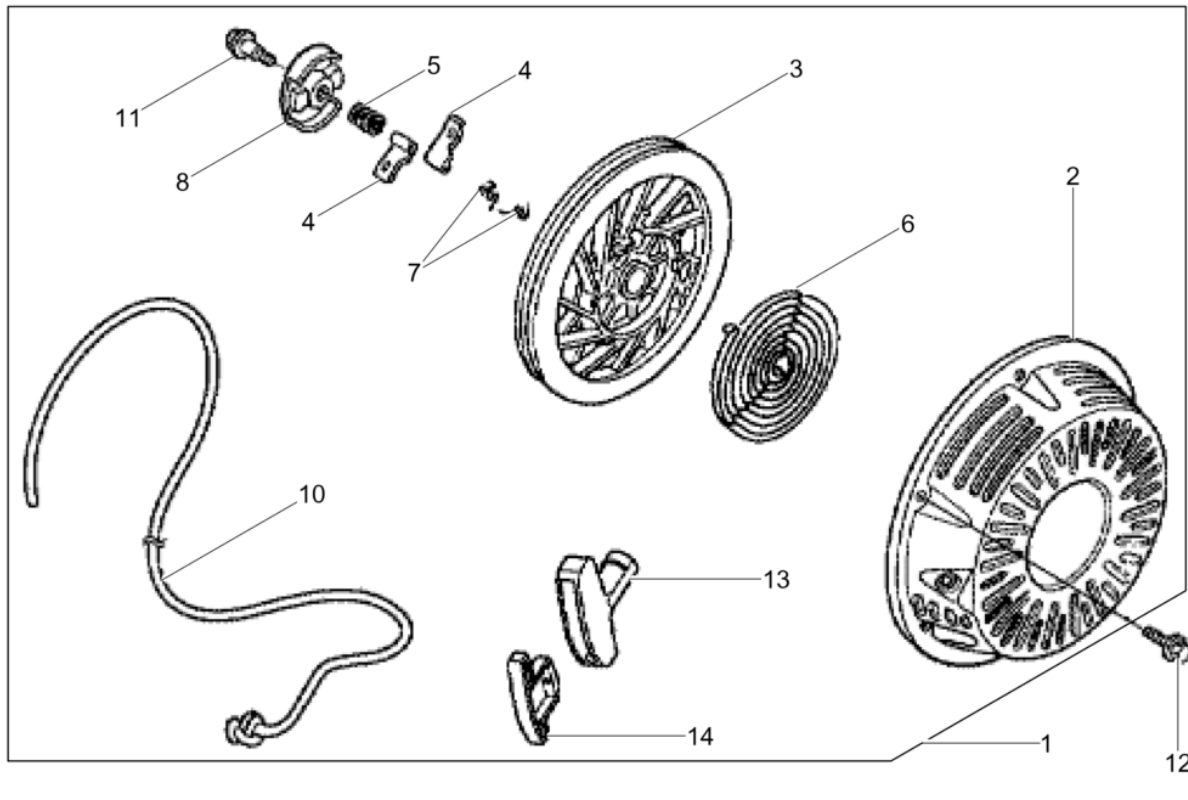

Pos. Item	Artikel Nr. Item no.	Pc.	Unit	Beschreibung Descripción	Description Description	Abm. Dim.	Norm Standard
						Drehmoment Torque	Schmierstoff Lubricant
1	5100000425	1	pc	Anlasser Kpl. Arrancador cpl.	Starter cpl. Démarrreur cpl.		
1	5100003448	1	pc	Reversierstarter Kpl. Starter reversible cpl.	Recoil starter cpl. Démarrreur réversible cpl.		
2	5000082839	1	pc	Startergehäuse Caja del arrancador	Starter housing Carter de démarrage		
3	5000082840	1	pc	Seilscheibe Polea	Starter pulley Poulie de démarrage		
4	5000081645	2	pc	Sperrklinke Trinquete	Ratchet Cliquet		
5	5000081646	1	pc	Feder Resorte	Spring Ressort		
6	5000081647	1	pc	Rückholfeder Resorte	Spring Ressort		
7	5000081648	2	pc	Feder Resorte	Spring Ressort		
8	5000081649	1	pc	Federgehäuse Carcasa de resorte	Spring housing Logement du ressort		
10	5000082842	1	pc	Starterseil Cuerda	Rope Corde		
10	5000208619	1	pc	Starterseil Cuerda	Rope Corde		
11	5000081658	1	pc	Schraube Tornillo	Screw Vis		
12	5000071053	3	pc	Schraube Tornillo	Screw Vis	M6 x 10 10Nm/7ft.lbs	
13	5100000428	1	pc	Griff Empuñadura	Handle Poignée		
14	5100000429	1	pc	Griff Empuñadura	Handle Poignée		

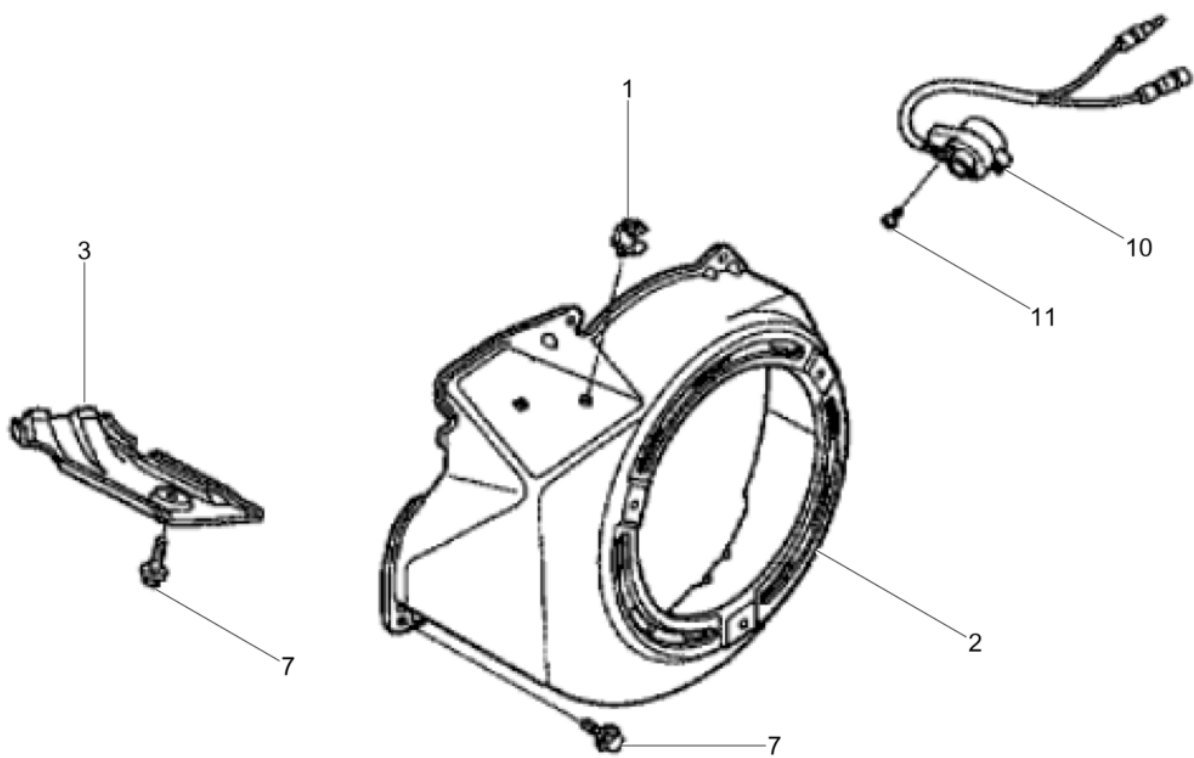

Pos. Item	Artikel Nr. Item no.	Pc.	Unit	Beschreibung Descripción	Description Description	Abm. Dim.	Norm Standard
						Drehmoment Torque	Schmierstoff Lubricant
1	5000074689	1	pc	Klemme Sujetador	Clip Agrafe		
2	5100003443	1	pc	Deckel Kpl. Tapa cpl.	Cover cpl. Couvercle cpl.		
3	5100000422	1	pc	Deckel Kpl. Tapa cpl.	Cover cpl. Couvercle cpl.		
3	5200000426	1	pc	Deckel Tapa	Cover Couvercle		
7	5000053990	6	pc	Schraube Tornillo	Screw Vis	M6 x 12 10Nm/7ft.lbs	
10	5100000436	1	pc	Motorabschalter Kpl. Parada del motor cpl.	Engine stop cpl. Arrêt du moteur cpl.		
11	5100000448	2	pc	Schraube Tornillo	Screw Vis		

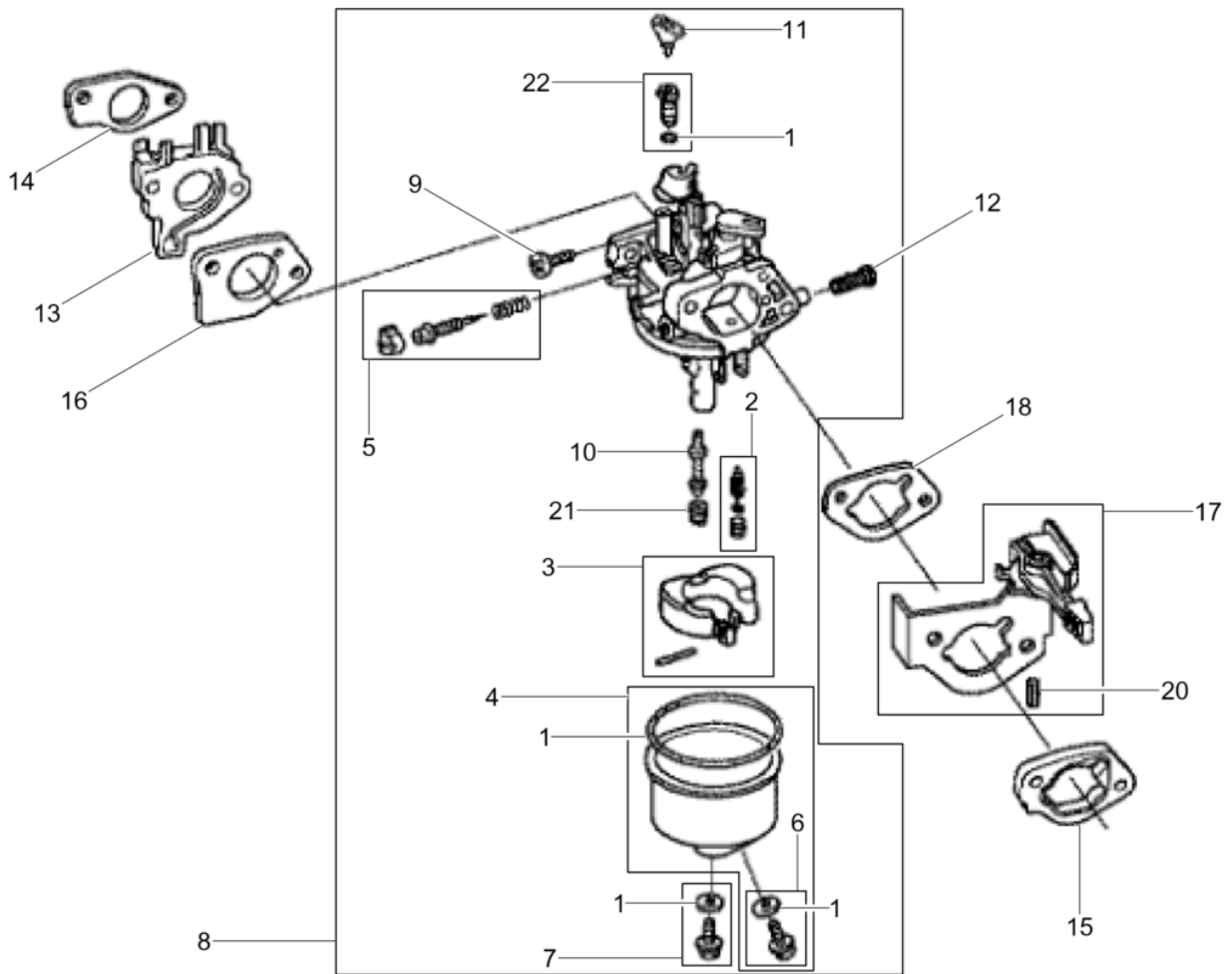

Pos. Item	Artikel Nr. Item no.	Pc.	Unit	Beschreibung Descripción	Description Description	Abm. Dim.	Norm Standard
						Drehmoment Torque	Schmierstoff Lubricant
1	5000158465	1	pc	Dichtungssatz Juego de juntas	Gasket set Jeu de joints		
2	5000074759	1	pc	Schwimmernadel Aguja del flotador	Float needle Aiguille de flotteur		
3	5000217483	1	pc	Schwimmer Kpl. Juego de flotador	Set-carburetor float Jeu de flotteur		
4	5000106974	1	pc	Schwimmergehäuse Kpl. Cámara de flotador cpl.	Float housing cpl. Cuve à niveau constant cpl.		
4	5000150267	1	pc	Schwimmer Kpl. Juego de flotador	Set-carburetor float Jeu de flotteur		
5	5000158521	1	pc	Gewindestift Tornillo	Setscrew Vis		
6	5000073273	1	pc	Schraube Mit Scheibe Tornillo con arandela	Screw w/washer Vis avec rondelle		
7	5100038226	1	pc	Schraube Tornillo	Screw Vis		
8	5100038227	1	pc	Vergaser Kpl. Carburador cpl.	Carburetor cpl. Carbureteur cpl.		
9	5000071018	1	pc	Anschlagschraube Tornillo de tope	Throttle stop screw Vis		
10	5100038228	1	pc	Hauptdüse Chicler principal	Main jet Gicleur principal		
11	5000089281	1	pc	Manschettensatz Juego-collar	Set-collar Jeu-collet		
12	5000226458	1	pc	Sieb Filtro	Filter Filtre		
13	5200000436	1	pc	Isolator Aislador	Insulator Isolant		
14	5200000438	1	pc	Dichtungen Empaques	Gasket Joints		
15	5000074761	1	pc	Distanzstück Espaciador	Carburetor mount spacer Pièce d'écartement		
16	5200000437	1	pc	Dichtungen Empaques	Gasket Joints		
17	5100034524	1	pc	Chokehebel Kpl. Palanca estranguladora cpl.	Choke control lever cpl. Levier d'étrangleur cpl.		
18	5100003436	1	pc	Dichtung Junta	Seal Joint		
20	5000071014	1	pc	Stift Pasador	Pin Goupille	2 x 12	
21	5000162705	1	pc	Hauptdüse Chicler principal	Main jet Gicleur principal	98	
21	5000162706	1	pc	Hauptdüse Gicleur principal	Main jet Gicleur prinzipal	102	
21	5100000456	1	pc	Hauptdüse Chicler principal	Main jet Gicleur principal		
22	5000084630	1	pc	Leerlaufdüse Gicleur para marcha en vacío	Idle jet Gicleur secondaire	40	

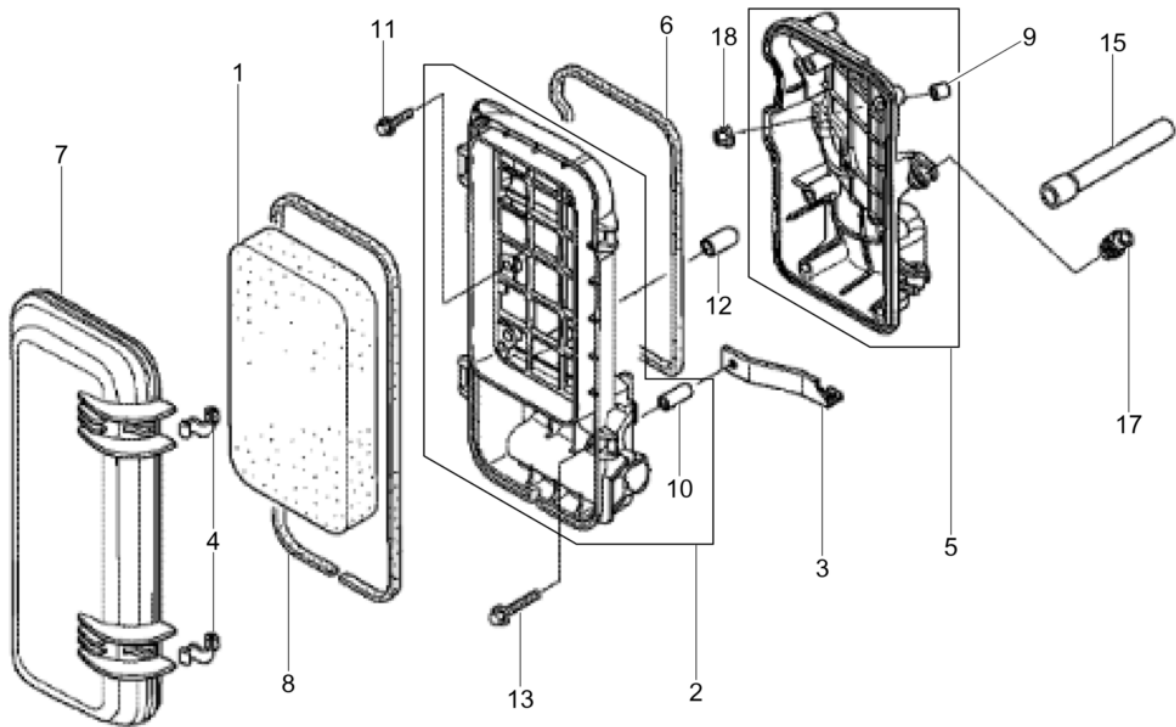



Pos. Item	Artikel Nr. Item no.	Pc.	Unit	Beschreibung Descripción	Description Description	Abm. Dim.	Norm Standard
						Drehmoment Torque	Schmierstoff Lubricant
1	5000158502	1	pc	Filtereinsatz Cartucho filtrante	Filter insert Element filtrant		
2	5100001468	1	pc	Halter Soporte	Bracket Équerre		
3	5100003434	1	pc	Halterung Soporte	Fixing device Bague de retenue		
4	5100003435	2	pc	Feder Resorte	Spring Ressort		
5	5100038222	1	pc	Konsole Kpl. Consola cpl.	Console cpl. Console cpl.		
6	5100003437	1	pc	Dichtung Junta	Seal Joint		
7	5100038223	1	pc	Luffilterdeckel Tapa filtro de aire	Air filter cover Couvercle filtre à air		
8	5100003439	1	pc	Dichtung Junta	Seal Joint		
9	5100038224	2	pc	Hülse Collar	Collar Douille		
10	5100003440	1	pc	Hülse Collar	Sleeve Douille		
11	5000157532	4	pc	Flanschbolzen Tornillo de perno	Flange bolt Vis de boulon	M5 x 18	
12	5000226543	1	pc	Dichtung Junta	Gasket Joint		
13	5100003502	1	pc	Flanschschraube 6X32 Tornillo de brida	Flange screw Vis de bride	6x32	
15	5100003391	1	pc	Entlüftungsschlauch Línea de purgado	Breather tube Tuyau d'évacuation purge		
17	5000213394	1	pc	Gummipuffer Bloque silente	Silent block Silentbloc		
18	5000071056	2	pc	Mutter Tuerca	Nut Erou	M6	

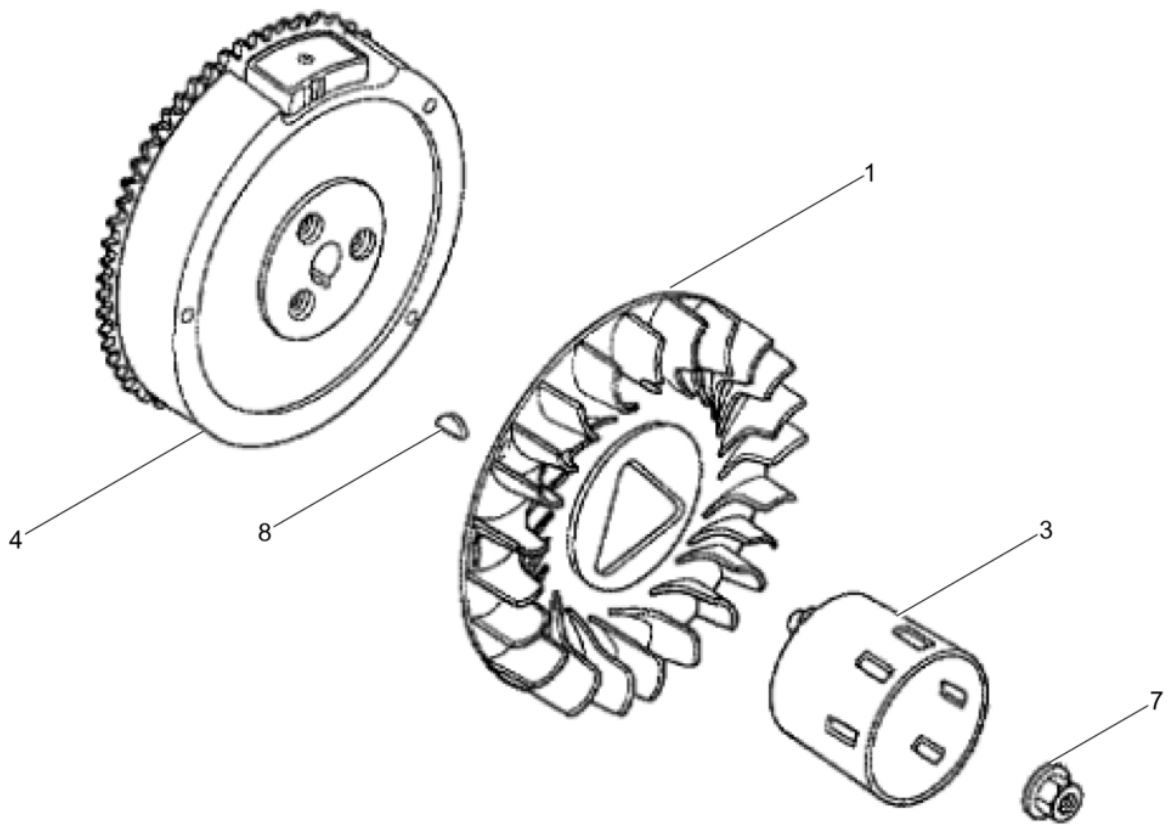

Pos. Item	Artikel Nr. Item no.	Pc.	Unit	Beschreibung Descripción	Description Description	Abm. Dim.	Norm Standard
						Drehmoment Torque	Schmierstoff Lubricant
1	5000209989	1	pc	Gebläserad Ventilador	Fan wheel Roue d'aeration		
3	5000089276	1	pc	Starterscheibe Arandela del starter	Starter pulley Rondelle du lanceur		
4	5100000433	1	pc	Schwungrad Kpl. Volante cpl.	Fly wheel cpl. Volant cpl.		
7	5000116736	1	pc	Mutter Tuerca	Nut Ecrou	16M	
8	5000074672	1	pc	Scheibenfeder Lengüeta redonda	Woodruff key Clavette	25 x 18	

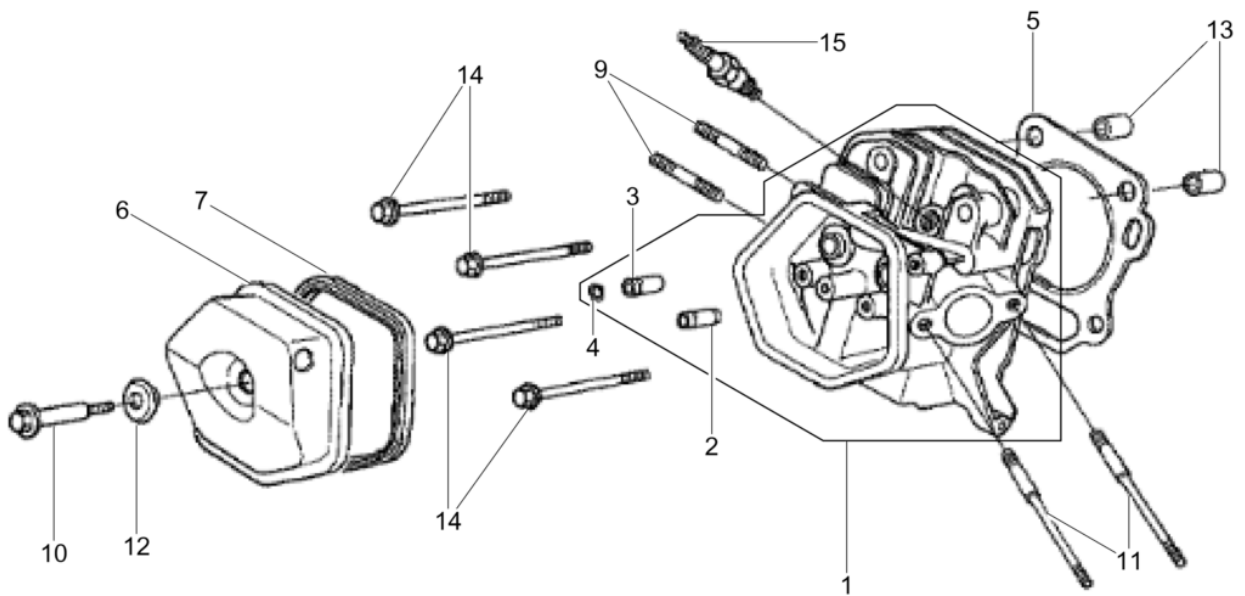

Pos. Item	Artikel Nr. Item no.	Pc.	Unit	Beschreibung Descripción	Description Description	Abm. Dim.	Norm Standard
						Drehmoment Torque	Schmierstoff Lubricant
1	5100038229	1	pc	Zylinderkopf Kpl. Culata cpl.	Cylinder head cpl. Culasse cpl.		
2	5000110602	1	pc	Ventilführung Guíaválvula	Valve guide Guide de soupape		
3	5000074648	1	pc	Ventilführung Guíaválvula	Valve guide Guide de soupape		
4	5000074660	1	pc	Sicherungsring Anillo de retención	Retaining ring Bague d'arrêt	11,9	
5	5100000356	1	pc	Zylinderkopfdichtung Junta de culata del cilindro	Cylinder head gasket Joint de culasse de cylindre		
6	5000089273	1	pc	Ventilhaube Tapa de válvula	Valve hood Couvercle culbuteur		
7	5000074645	1	pc	Zylinderkopfdichtung Junta de culata del cilindro	Cylinder head gasket Joint de culasse de cylindre		
9	5000213388	2	pc	Gewindebolzen Perno roscado	Threaded bolt Boulon fileté		
10	5100000450	1	pc	Schraube Tornillo	Screw Vis		
10	5200000468	1	pc	Bolzen Perno	Bolt Boulon		
11	5100003482	2	pc	Bolzen 8X115 Perno	Bolt Boulon	8x115	
12	5000074657	1	pc	Scheibe Arandela	Washer Rondelle		
13	5000074652	2	pc	Passstift Espiga	Dowel pin Cheville	12 x 20	
14	5100003507	4	pc	Flanschschraube 10X80 Tornillo de brida	Flange screw Vis de bride	10x80	
15	5000209776	1	pc	Zündkerze Bujía	Spark plug Bougie		

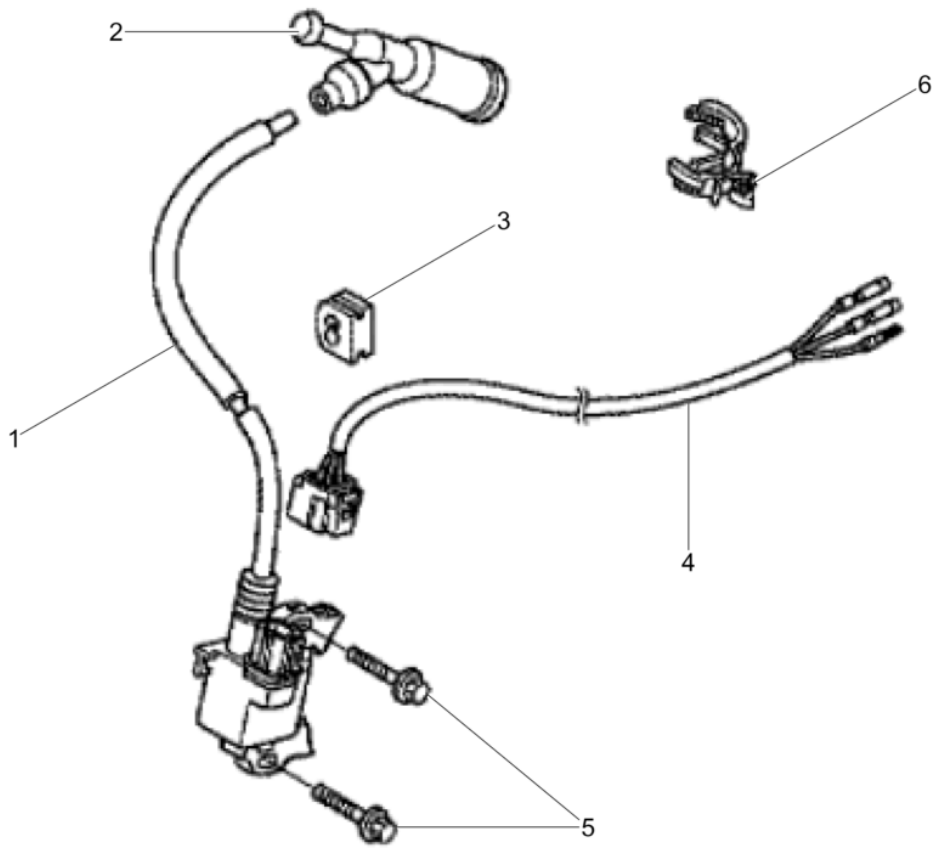

Pos. Item	Artikel Nr. Item no.	Pc.	Unit	Beschreibung Descripción	Description Description	Abm. Dim.	Norm Standard
						Drehmoment Torque	Schmierstoff Lubricant
1	5200000453	1	pc	Zündspule Bobina de encendido	Ignition coil Bobine d'allumage		
2	5000217491	1	pc	Zündkerzenstecker Enchufe de bujía	Spark plug terminal cap Porte bougies		
3	5000081611	1	pc	Tülle Ojal	Grommet Passe-fil		
4	5100000434	1	pc	Kabelbaum Kpl. Mazo de cables cpl.	Wire harnes cpl. Harnais de câbles cpl.		
5	5000070966	2	pc	Schraube Tornillo	Screw Vis	M6 x 28 10Nm/7ft.lbs	
6	5000076375	1	pc	Klemme Sujetador	Clip Agrafe		

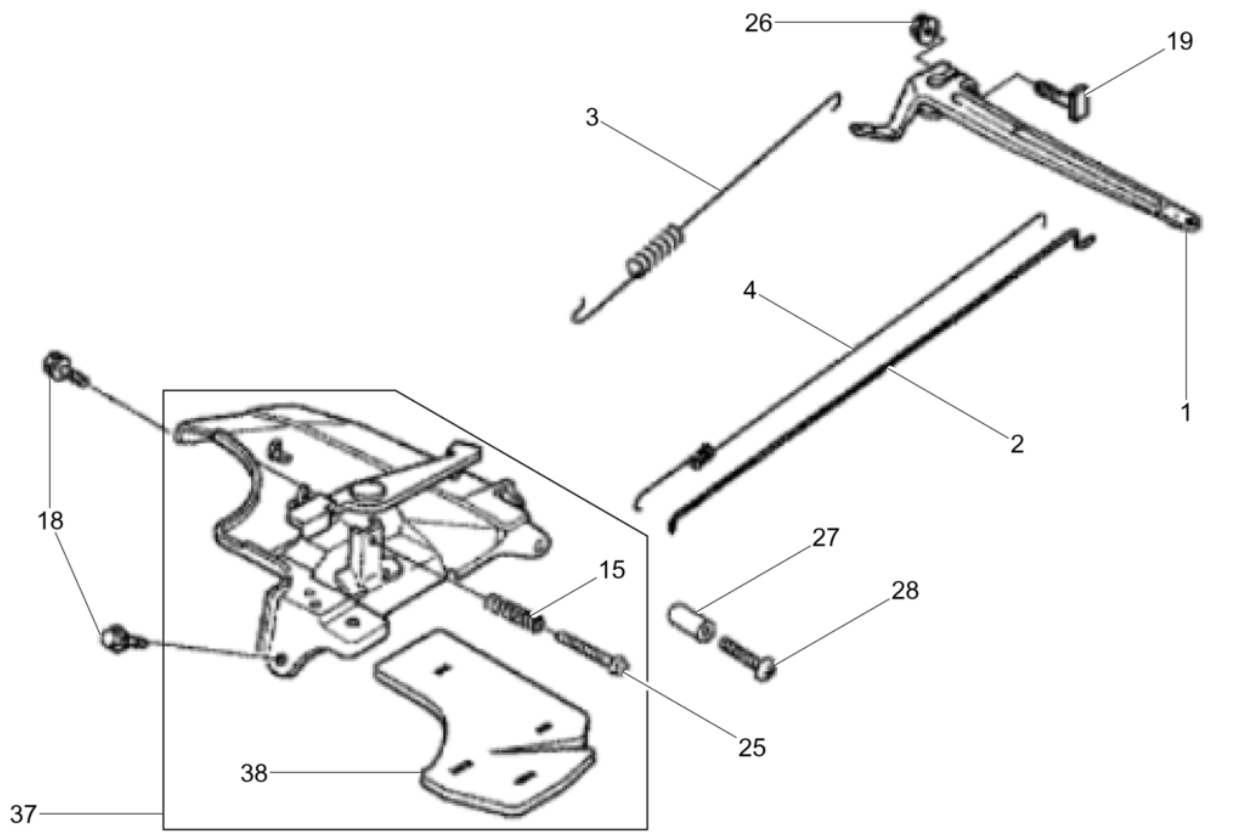



Pos. Item	Artikel Nr. Item no.	Pc.	Unit	Beschreibung Descripción	Description Description	Abm. Dim.	Norm Standard
						Drehmoment Torque	Schmierstoff Lubricant
1	5000075845	1	pc	Reglerhebel Palanca de regulador	Governor lever Lever régulateur		
2	5000075844	1	pc	Reglerstange Varillaje de regulación	Governor rod Tige de régulateur		
3	5100003421	1	pc	Feder Resorte	Spring Ressort		
4	5000075843	1	pc	Feder Resorte	Spring Ressort		
15	5000054088	1	pc	Feder Resorte de ajuste	Adjusting spring Ressort d'ajustage		
18	5000053990	2	pc	Schraube Tornillo	Screw Vis	M6 x 12 10Nm/7ft.lbs	
19	5100000451	1	pc	Schraube Tornillo	Screw Vis		
25	5000116740	1	pc	Schraube Tornillo	Screw Vis	5x45	
26	5000071056	1	pc	Mutter Tuerca	Nut Erou	M6	
27	5000156684	1	pc	Abstandsstück Espaciador	Spacer Pièce d'écartement		
28	5000156685	1	pc	Schraube Tornillo	Screw Vis	M5x25	
37	5100038230	1	pc	Regler Kpl. Regulador cpl.	Governor cpl. Régulateur cpl.		
38	5100003425	1	pc	Isolation Aislador	Insulator Isolant		

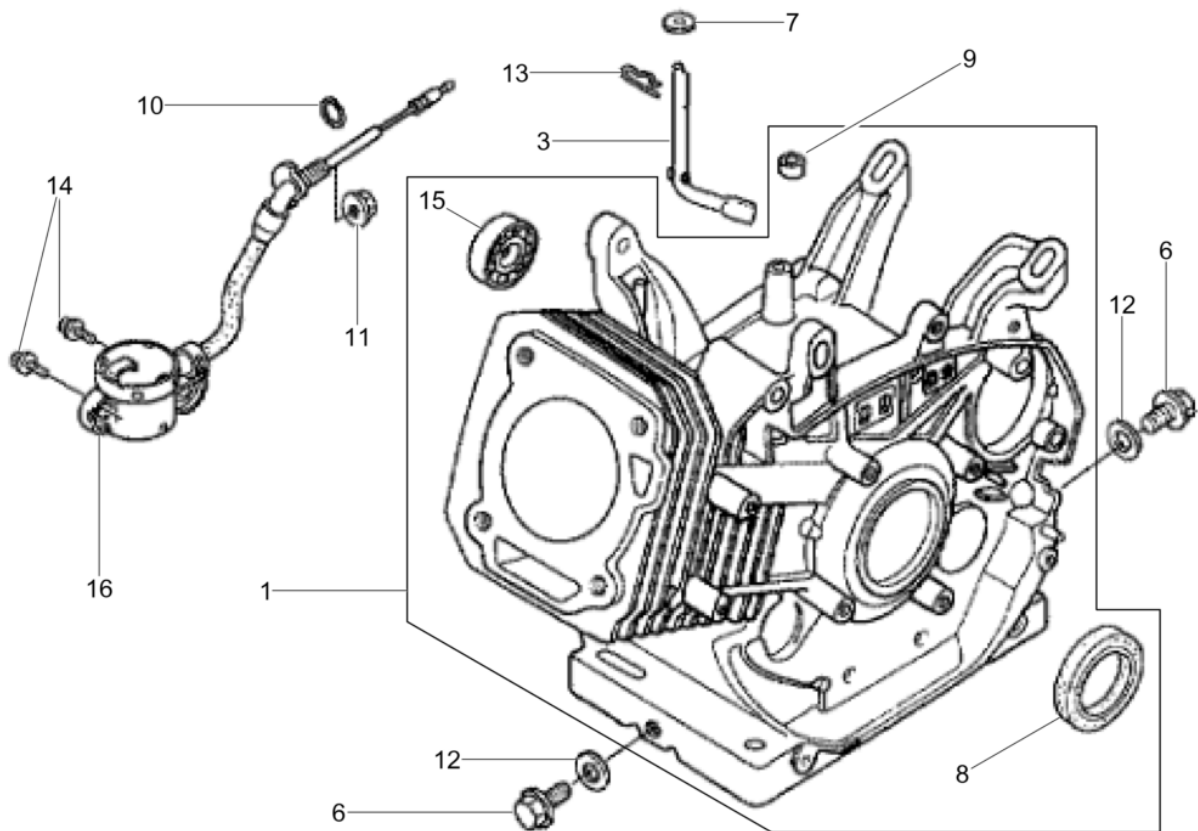

Pos. Item	Artikel Nr. Item no.	Pc.	Unit	Beschreibung Descripción	Description Description	Abm. Dim.	Norm Standard
						Drehmoment Torque	Schmierstoff Lubricant
1	5200000469	1	pc	Zylinder Kpl. Cilindro compl.	Cylinder cpl. Cylindre compl.		
3	5000110114	1	pc	Reglerwelle Eje de regulador	Governor shaft Arbre régulateur		
6	5100038225	2	pc	Ablassschraube Tornillo de vaciado	Drain screw Vis de décharge		
7	5000074656	1	pc	Scheibe Arandela	Washer Rondelle	8.2 x 17 x 0.8	
8	5200000471	1	pc	Wellendichtring Sello del eje	Shaft seal Bague d'étanchéité		
9	5000157749	1	pc	Öldichtung Junta de aceite	Oil seal Joint d'huile	8 x 14 x 5	
10	5000208616	1	pc	O-Ring Anillo-o	O-ring Joint torique	14M	
11	5000072332	1	pc	Flanschmutter Tuerca de reborde	Flange nut Erou de bride	M10	
12	5000053994	2	pc	Dichtring Anillo sellador	Ring seal Rondelle à étancher	12M	
13	5000110110	1	pc	Vorsteckfeder Clavija hendida	Cotter pin Goupille fendue	10	
14	5100003498	2	pc	Flanschschraube 6X12 Tornillo de brida	Flange screw Vis de bride	6x12	
15	5000074640	1	pc	Rillenkugellager Rodamiento de bolas	Grooved ball bearing Roulement à billes		
16	5000217492	1	pc	Ölschutzschalter Kpl. Interruptor compl.	Switch assembly Interrupteur compl.		

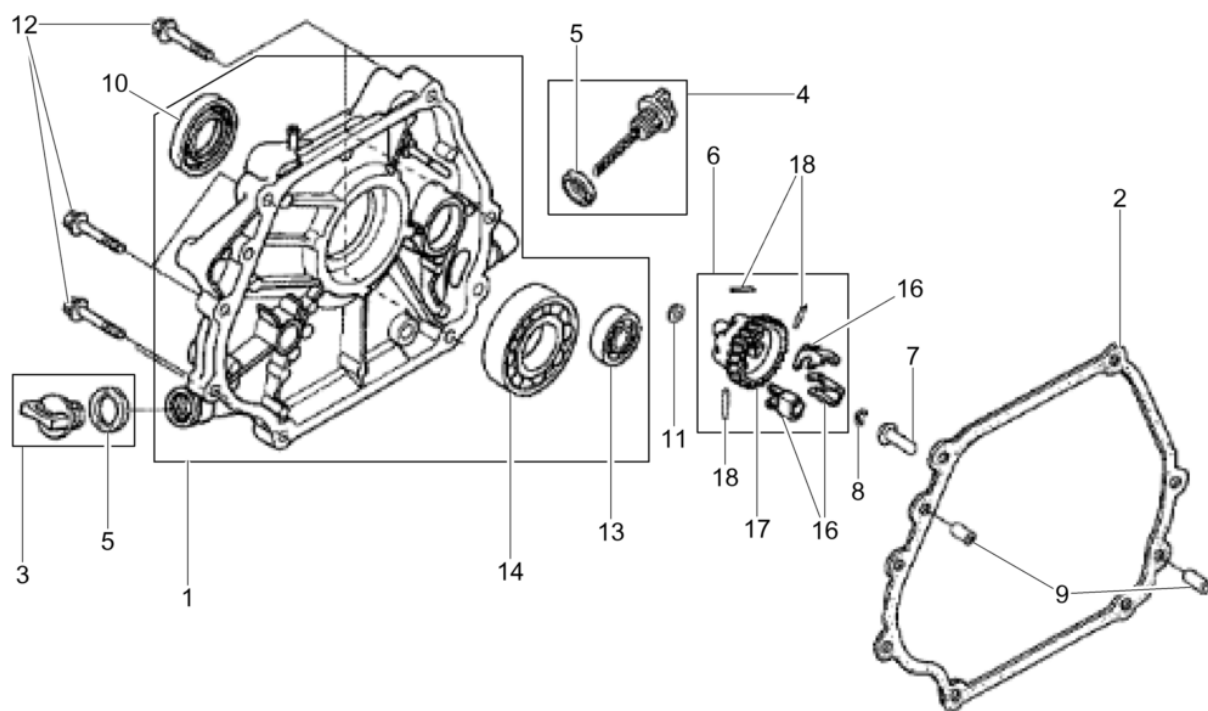

Pos. Item	Artikel Nr. Item no.	Pc.	Unit	Beschreibung Descripción	Description Description	Abm. Dim.	Norm Standard
						Drehmoment Torque	Schmierstoff Lubricant
1	5100000347	1	pc	Kurbelgehäusedeckel Kpl. Tapa del cárter cpl.	Crankcase cover cpl. Couvercle de carter cpl.		
2	5100000350	1	pc	Dichtung Junta	Gasket Joint		
3	5100031607	1	pc	Kappe-Ölfüller Llenador de aceite	Oil filler cap Remplisseur d'huile		
4	5000217482	1	pc	Ölpeilstab Kpl. Varilla de sondear aceite cpl.	Oil dip stick cpl. Jauge de niveau d'huile cpl.		
5	5000162647	2	pc	Dichtung Junta de estanqueidad	Gasket Garniture		
6	5000082828	1	pc	Reglersatz Juego-regulador	Kit-governor Jeu-régulateur		
7	5000074632	1	pc	Gleitstück Manguito	Slider Douille		
8	5000081615	1	pc	Sicherungsring Anillo de retención	Retaining ring Bague d'arrêt		
9	5000081617	2	pc	Passtift Espiga	Dowel pin Cheville	8 x 12	
10	5200000471	1	pc	Wellendichtring Sello del eje	Shaft seal Bague d'étanchéité		
11	5000071639	1	pc	Scheibe Arandela	Washer Rondelle	6M	
12	5000116734	7	pc	Bolzen Perno	Bolt Boulon	M8 x 40	
13	5100003509	1	pc	Radialkugllager 6202 Rodamiento de bolas	Grooved ball bearing Roulement à billes		
14	5100003512	1	pc	Radialkugellager 6207 Rodamiento de bolas	Grooved ball bearing Roulement à billes		
16	5000075788	3	pc	Reglergewicht Peso	Weight Poids		
17	5000082829	1	pc	Halter Soporte	Holder Attache		
18	5000074634	3	pc	Stift Pasador	Pin Goupille		

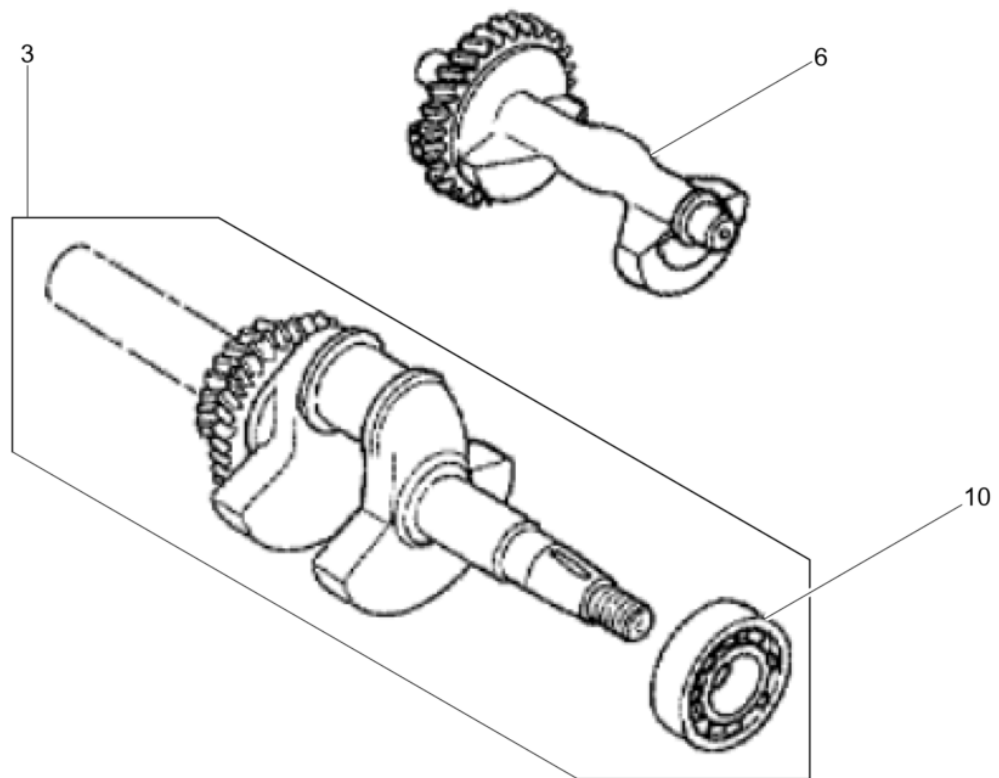

Pos. Item	Artikel Nr. Item no.	Pc.	Unit	Beschreibung Descripción	Description Description	Abm. Dim.	Norm Standard
						Drehmoment Torque	Schmierstoff Lubricant
3	5100003381	1	pc	Kurbelwelle Kpl. Cigüeñal cpl.	Crankshaft cpl. Vilebrequin cpl.		
6	5100038231	1	pc	Gewicht Peso	Weight Poids		
10	5100003486	1	pc	Radialkuegellager 6207 Rodamiento de bolas	Grooved ball bearing Roulement à billes		

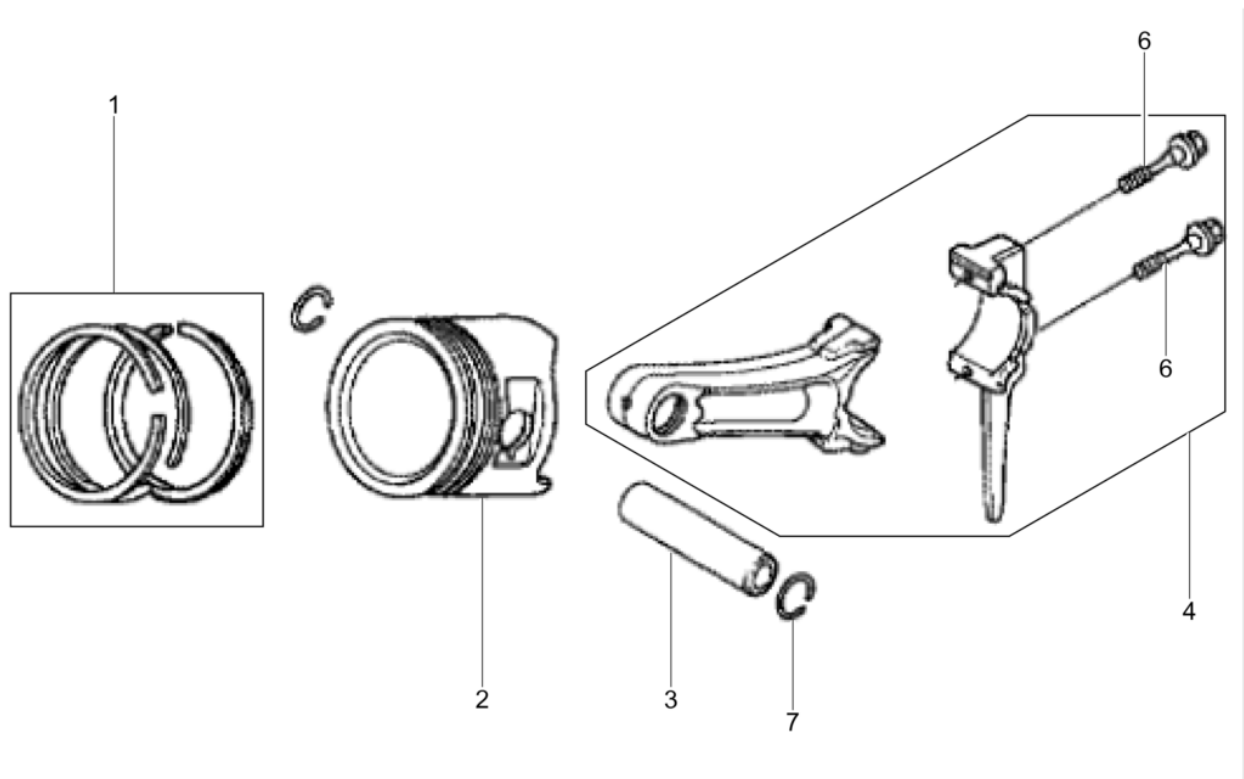



Pos. Item	Artikel Nr. Item no.	Pc.	Unit	Beschreibung Descripción	Description Description	Abm. Dim.	Norm Standard
						Drehmoment Torque	Schmierstoff Lubricant
1	5100000364	1	pc	Kolbenringsatz Juego de aros de pistón	Set of piston rings Jeu de segments de piston		
1	5100003354	1	pc	Kolbenringsatz 0,25 Juego de aros de pistón	Set of piston rings Jeu de segments de piston	0,25	
1	5100003359	1	pc	Kolbenringsatz 0,5 Juego de aros de pistón	Set of piston rings Jeu de segments de piston	0,5	
1	5100003564	1	pc	Kolbenringsatz Juego de aros de pistón	Set of piston rings Jeu de segments de piston		
2	5100000370	1	pc	Kolben (0,50) Pistón (0,50)	Piston (0,50) Piston (0,50)		
2	5100038232	1	pc	Kolben Pistón	Piston Piston		
2	5200000487	1	pc	Kolben Pistón	Piston Piston	0,25	
2	5200000489	1	pc	Kolben Pistón	Piston Piston	0,75	
3	5200000490	1	pc	Kolbenbolzen Pasador de pistón	Piston pin Axe de piston		
4	5100000375	1	pc	Pleuelstange Kpl. Biela cpl.	Connecting rod cpl. Bielle cpl.		
4	5200000540	1	pc	Pleuel Kpl. Biela compl.	Connecting rod cpl. Bielle compl.	-0,25	
6	5000075807	2	pc	Schraube Tornillo	Screw Vis		
7	5000075804	2	pc	Sicherungsring Anillo de retención	Retaining ring Bague d'arrêt	22,44	

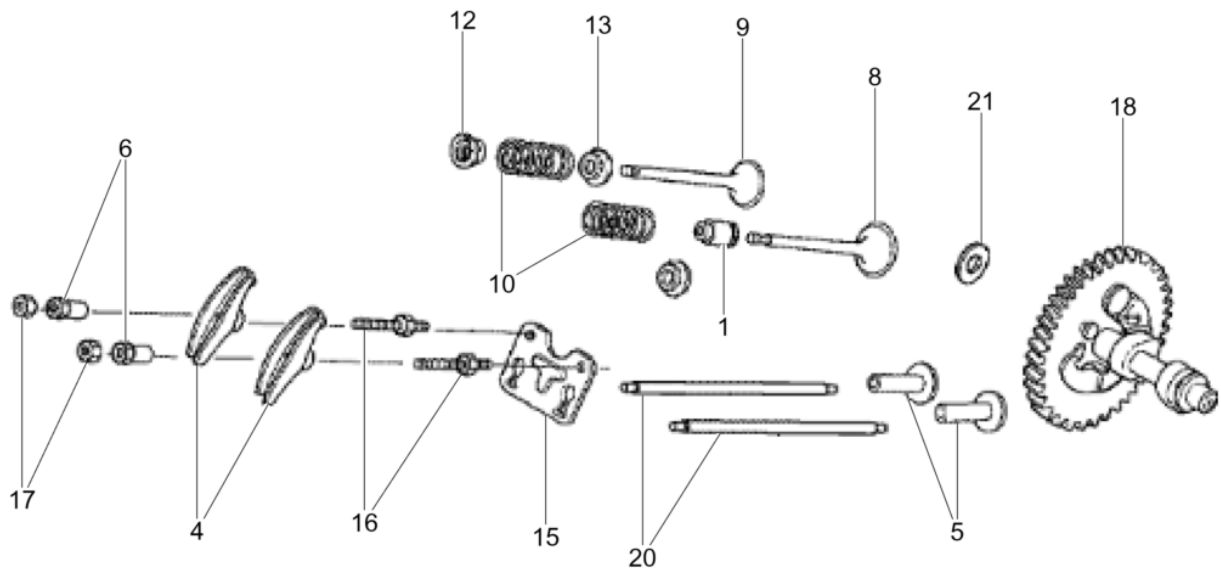

Pos. Item	Artikel Nr. Item no.	Pc.	Unit	Beschreibung Descripción	Description Description	Abm. Dim.	Norm Standard
						Drehmoment Torque	Schmierstoff Lubricant
1	5000151750	1	pc	Dichtung Empaque	Gasket Garniture		
4	5000074675	2	pc	Kipphebel Balancín	Rocker arm Culbuteur		
5	5000074678	2	pc	Ventilstößel Levantaválvula	Valve tappet Poussoir		
6	5100031338	2	pc	Zapfen Pivote	Pin Pivot		
8	5100000382	1	pc	Einlassventil Válvula de admisión	Intake valve Soupape d'admission		
9	5100000384	1	pc	Ventil Válvula	Valve Soupape		
10	5000217481	2	pc	Feder Resorte	Spring Ressort		
12	5200000495	1	pc	Federgehäuse Soporte	Spring holder Support		
13	5000074659	1	pc	Federteller Resorte	Spring Ressort		
15	5000209985	1	pc	Platte Placa	Plate Plaque		
16	5000072778	2	pc	Gewindebolzen Perno prisionero	Stud Boulon	8	
17	5000070984	2	pc	Sechskantmutter Contratuercas	Locknut Contre-écrou	1/4-28in	
18	5100038233	1	pc	Nockenwelle Kpl. Árbol de levas cpl.	Camshaft cpl. Arbre à cames cpl.		
20	5000209984	2	pc	Stoßstange Varilla de empuje	Push rod Poussoir		
21	5000209986	1	pc	Druckscheibe Arandela de presión	Thrust washer Rondelle de pression		

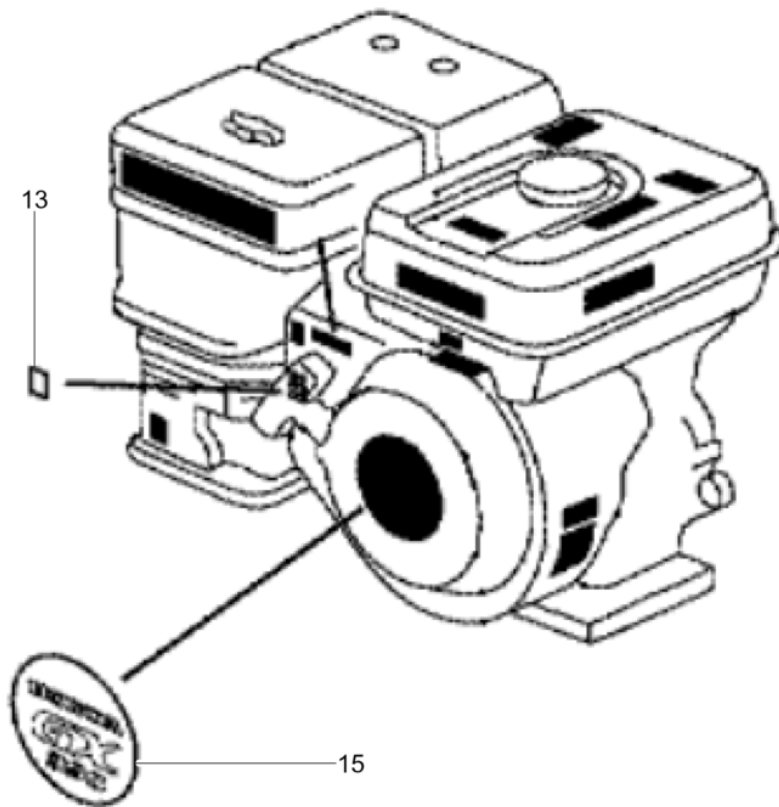

Pos. Item	Artikel Nr. Item no.	Pc.	Unit	Beschreibung Descripción	Description Description	Abm. Dim.	Norm Standard
						Drehmoment Torque	Schmierstoff Lubricant
13	5100036255	1	pc	Aufkleber Calcomania	Label Autocollant		
15	5200000460	1	pc	Aufkleber Calcomania	Label Autocollant		

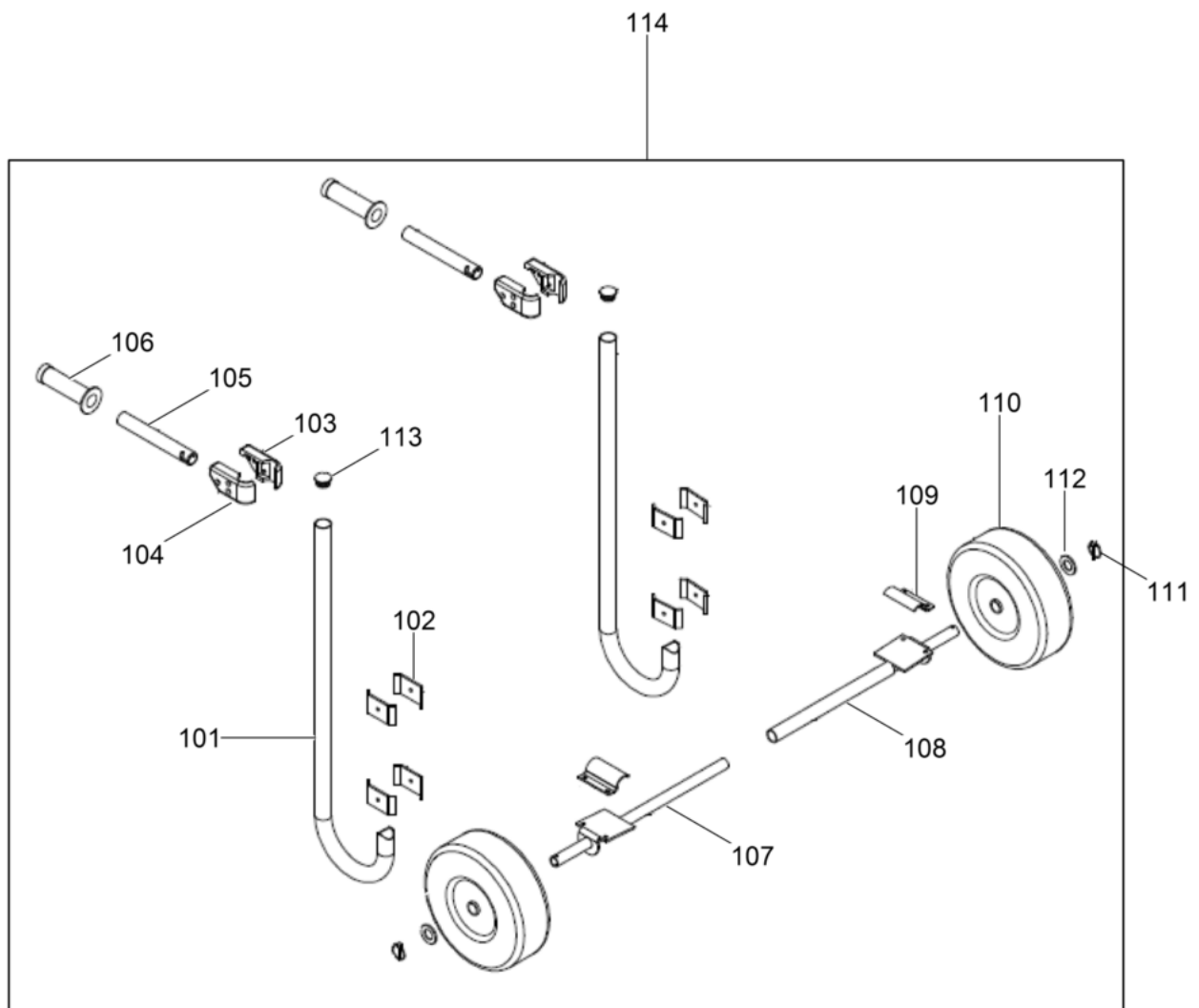

Pos. Item	Artikel Nr. Item no.	Pc.	Unit	Beschreibung Descripción	Description Description	Abm. Dim.	Norm Standard
						Drehmoment Torque	Schmierstoff Lubricant
101	5000158548	2	pc	Handgriff Empuñadura	Handle Poignée		
102	5000171871	8	pc	Klammer Grampa	Clamp Pince		
103	5000158558	2	pc	Abdeckung Links Cubierta izquierda	Covering left Couverture gauche		
104	5000158559	2	pc	Abdeckung Rechts Cobertura derecha	Covering right Couvercle droite		
105	5100001498	2	pc	Handgriff Empuñadura	Handle Poignée		
106	5000158557	2	pc	Handgriff Empuñadura	Handle Poignée		
107	5000171868	1	pc	Achse Eje	Axle Axe		
108	5000171869	1	pc	Achse Eje	Axle Axe		
109	5000158538	2	pc	Achsschelle Abrazadera	Clamp Agrafe		
110	5000158551	2	pc	Rad Rueda	Wheel Roue		
111	5000158556	2	pc	Sicherungssplint Clavija hendida	Cotter pin Goupille fendue		
112	5000158552	2	pc	Unterlegscheibe Arandela	Supporting disc Rondelle		
113	5000158561	2	pc	Kappe Tapa	Cap Chapeau		
114	5200000752	1	pc	Transportvorrichtung Juego de ruedas	Transport wheel kit Jeu de roues		

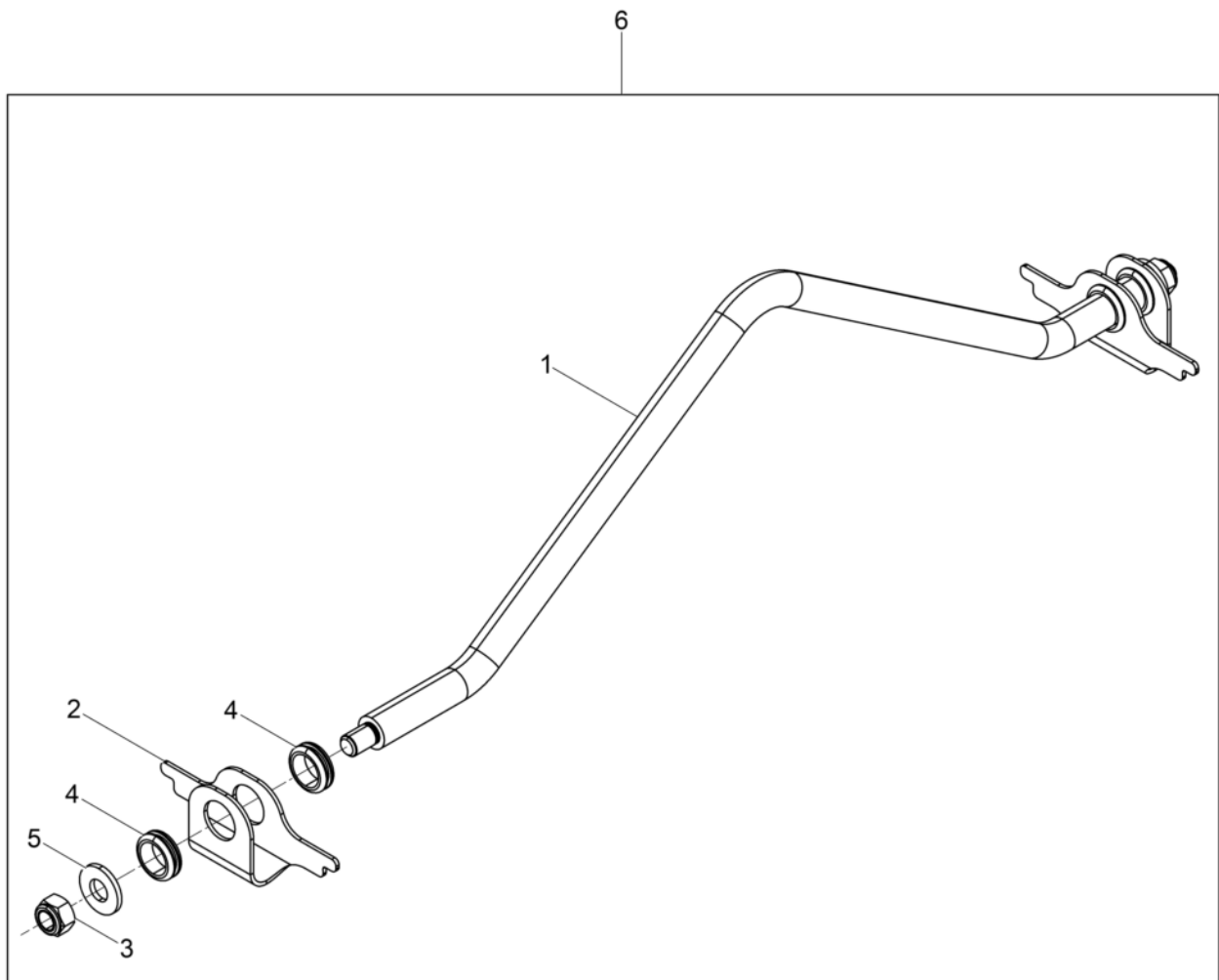



Pos. Item	Artikel Nr. Item no.	Pc.	Unit	Beschreibung Descripción	Description Description	Abm. Dim.	Norm Standard
						Drehmoment Torque	Schmierstoff Lubricant
1	5100001998	1	pc	Kranbügel Estribo	Shackle Étrier		
2	5100001999	2	pc	Schelle Abrazadera	Clamp Collier		
3	5000021267	2	pc	Sechskantmutter Tuerca hexagonal	Hexagon nut Écrou hexagonal	M16	DIN980
4	5100004502	4	pc	Gummitülle Casquillo de goma	Rubber funnel Passe fil en caoutchouc		
5	5100003761	2	pc	Sicherungsblech Chapa de seguridad	Locking plate Tôle de sûreté		
6	5100002000	1	pc	Kraufhängung Kpl. Ojete de suspensión de grua cp	Crane lifting eye cpl. Oeillet de suspension pour		

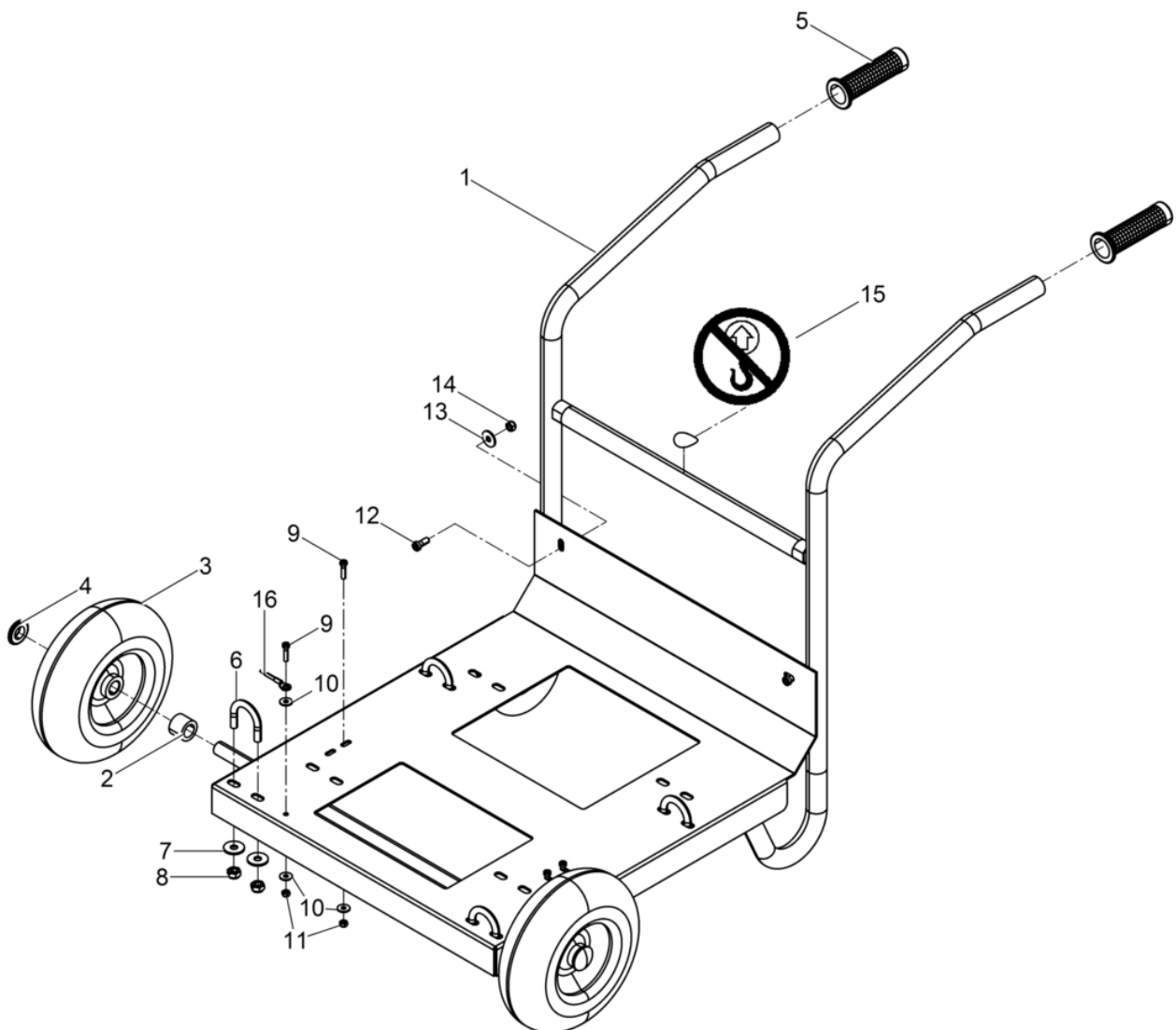

Pos. Item	Artikel Nr. Item no.	Pc.	Unit	Beschreibung Descripción	Description Description	Abm. Dim.	Norm Standard
						Drehmoment Torque	Schmierstoff Lubricant
1	5100002010	1	pc	Transportwagen Carro transportación	Cart transportation Voiturette transport		
2	5100003760	2	pc	Hülse Collar	Collar Douille		
3	5002003396	2	pc	Rad Rueda	Tire Roue		
4	5000039752	2	pc	Starlockkappen Tapa	Cap Chapeau	20 mm	
5	5100004501	2	pc	Griff Mango	Handle Poignée		
6	5100005038	4	pc	Rundstahlbügel Estribo	Shackle Étrier	M10	
7	5000010375	8	pc	Scheibe Arandela	Flat washer Rondelle	B10,5	DIN9021
8	5000216588	8	pc	Sechskantmutter Tuerca hexagonal	Hexagon nut Écrou hexagonal	M10	DIN980
9	5000011269	5	pc	Zylinderschraube Tornillo cilíndrico	Cheese head screw Vis à tête cylindrique	M6 x 25 10Nm/7ft.lbs	DIN6912
10	5000010373	6	pc	Scheibe Arandela	Flat washer Rondelle	6	ISO7093
11	5000021679	5	pc	Sechskantmutter Tuerca hexagonal	Hexagon nut Écrou hexagonal	M6	DIN980
12	5000011263	2	pc	Zylinderschraube Tornillo cilíndrico	Cheese head screw Vis à tête cylindrique	M8 x 20 25Nm/18ft.lbs	DIN6912
13	5000010374	2	pc	Scheibe Arandela	Flat washer Rondelle		
14	5000033356	2	pc	Sechskantmutter Tuerca hexagonal	Hexagon nut Écrou hexagonal		
15	5000220000	1	pc	Aufkleber-Warnhinweis Calcomanía-indicación	Instruction label Autocollant avec indication		
16	5000219670	1	pc	Schutzleiter Kpl. Toma a tierra cpl.	Ground wire cpl. Conducteur de sûreté cpl.		







**WACKER  
NEUSON**

