



**WACKER
NEUSON**

Ersatzteilkatalog
Spare parts catalog
Catálogo de piezas de repuesto
Catalogue de pièces de rechange

**Vibrationsplatte
Vibratory plate
Plancha vibratoria
Plaque vibrante**

DPU80rLem670



Type	DPU80rLem670
Material Number	5100024697
Version	102
Language	de en es fr



www.wackerneuson.com

Copyright © 07.2022
Wacker Neuson Produktion GmbH & Co. KG
Printed in Germany.
All rights reserved.

Ein Typenschild mit Typ, Artikelnummer, Version und Maschinen-Nummer ist an jedem Gerät angebracht. Die Daten von diesem Schild bitte notieren, damit sie auch bei Verlust oder Beschädigung des Schildes noch vorhanden sind. Der Typ, die Artikelnummer, die Versions-Nummer und die Maschinen-Nummer sind bei der Ersatzteilbestellung oder Nachfragen bezüglich Service-Informationen stets erforderlich.

Bei den in den Ersatzteillisten fettgedruckten Nummern handelt es sich um empfohlene Ersatzteile. Dies bedeutet, daß diese Teile bei normalen Anwendungsbedingungen natürlicher Abnutzung ausgesetzt sind und gelegentlich ersetzt oder überarbeitet werden müssen. Es wird geraten, diese Teile auf Lager bereit zu haben, um für Service-Arbeiten an diesem Gerät vorbereitet zu sein. Lagerbestände für diese und andere Teile, welche für ausgiebigere Reparaturarbeiten benötigt werden, können je nach Service-Gewohnheiten der einzelnen Kunden variieren.

Die Nummern meines Gerätes sind:

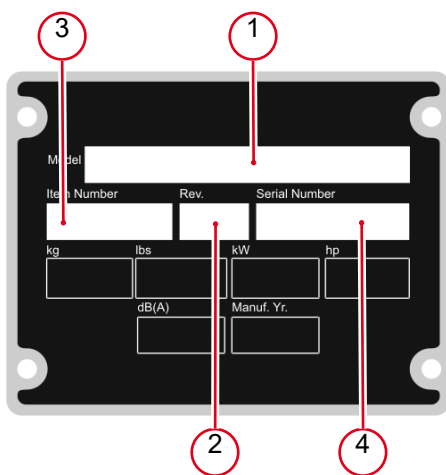

1. Typ
2. Version
3. Artikel-Nr.
4. Maschinen-Nr.

Umrechnungstabelle

Volumeneinheit	
1 ml	0.034 US fl.oz.
1 l	0.260 gal
Längeneinheit	
1 mm	0.039 in
1 m	3.280 ft
Gewicht	
1 kg	2.200 lbs
1 g	0.035 oz
Geschwindigkeit	
1 km/h	0.620 mph
Drehmoment	
1 Nm	0.740 ft.lbs

A nameplate listing the Model Number, Item Number, Revision, and Serial Number is attached to each unit. Please record the information found on this plate so it will be available should the nameplate become lost or damaged. When ordering parts or requesting service information, you will always be asked to specify the model, item number, revision number, and serial number of the unit.

Part Numbers appearing in boldface type are recommended spare parts. This means that these parts are subject to wear under normal operating conditions and may require periodic service or replacement. It is recommended that these items be stocked to meet the expected service requirements of this model. Actual stocking quantities of these and other parts used in more extensive repairs will depend on the service practices of each customer.

My machine's numbers are:



1. Model
2. Revision
3. Item No.
4. Serial No.

Conversion table

Volume unit	
1 ml	0.034 US fl.oz.
1 l	0.260 gal
Unit of length	
1 mm	0.039 in
1 m	3.280 ft
Weight	
1 kg	2.200 lbs
1 g	0.035 oz
Speed	
1 km/h	0.620 mph
Torque	
1 Nm	0.740 ft.lbs

Una placa de identificación con el modelo, número de referencia, nivel de revisión y número de serie ha sido añadida en cada máquina. Favor de anotar los datos en la placa en caso de que la placa de identificación sea destruida o perdida. En todos los pedidos para repuestos necesita siempre el modelo, el número de referencia, el nivel de revisión y el número de serie de la máquina en cuestión.

Los números de partes en negritas en las Listas Ilustradas de Partes son los repuestos recomendados, esto quiere decir que estas partes se desgastarán bajo circunstancias de funcionamiento normales y pueden requerir servicio periódico o su reemplazo. Se recomienda que el cliente mantenga un abastecimiento adecuado de estas partes para poder satisfacer la demanda requerida por el servicio a la máquina. La cantidad de repuestos que el cliente necesitará para reparaciones dependerá de la póliza de servicio de cada cliente.

Los números de mi máquina son:

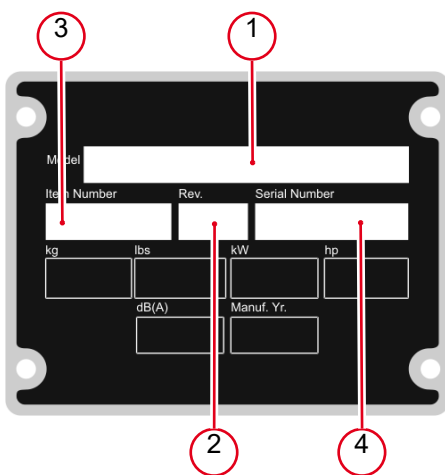

1. Modelo
2. Nivel de revisión
3. Número de referencia
4. Número de Serie

Tabla de conversión

Unidad de volumen	
1 ml	0.034 US fl.oz.
1 l	0.260 gal
Unidad de longitud	
1 mm	0.039 in
1 m	3.280 ft
Peso	
1 kg	2.200 lbs
1 g	0.035 oz
Velocidad	
1 km/h	0.620 mph
Par de apriete	
1 Nm	0.740 ft.lbs

Une plaque signalétique mentionnant le modèle, le numéro de référence, le niveau de revision et le numéro de série est fixée sur chaque machine. Veuillez noter les informations relevées sur cette plaque de façon à ce qu'elles soient toujours disponibles si la plaque signalétique venait à être perdue ou endommagée. Lorsque vous commandez des pièces détachées ou vous sollicitez des informations après-vente, on vous demandera toujours de préciser le modèle, le numéro de référence, le niveau de revision et le numéro de série de la machine.

Les numéros de pièces imprimés en caractères gras dans les Listes des Pièces Détachées de ce manuel sont les pièces détachées recommandées par la Wacker. Cela veut dire que ces pièces sont sujettes à usure dans des conditions de travail normales et peuvent nécessiter de l'entretien ou leur remplacement. Nous recommandons que vous disposiez d'un stock de ces pièces pour pouvoir satisfaire la demande d'entretien de cette machine. Le client doit décider lui-même de la quantité exacte de pièces de rechange qu'il disposera dans ses stocks.

Les numéros de ma machine son :

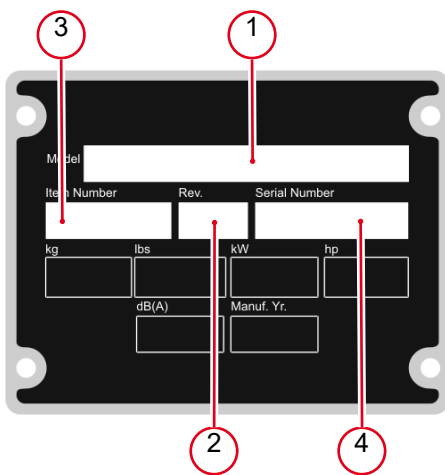

1. Typ
2. Version
3. Artikel-Nr.
4. Maschinen-Nr.

Table de conversion

Unité de volume	
1 ml	0.034 US fl.oz.
1 l	0.260 gal
Unité de longueur	
1 mm	0.039 in
1 m	3.280 ft
Poids	
1 kg	2.200 lbs
1 g	0.035 oz
Vitesse	
1 km/h	0.620 mph
Couple de serrage	
1 Nm	0.740 ft.lbs

Untermasse Kpl. DPU80r/90r Baseplate cpl. dpu80r/90r Masa inferior cpl. dpu80r/90r Masse inferieure cpl.	12
Erreger Kpl. DPU80r Exciter cpl. dpu80r Excitador cpl. dpu80r Excitateur cpl. dpu80r	14
Obermasse Kpl. DPU80r/90r Upper mass cpl. dpu80r/90r Masa superior cpl. dpu80r/90r Massa superieure cpl. dpu80r	18
Verkabelung Kpl. DPU80r/90r Cabling cpl. dpu80r/90r Cableado cpl. dpu80r/90r Câblage cpl. dpu80r/90r	20
Tank - Kühler DPU80/90 Tank - radiator dpu80/90 Tanque - radiador dpu80/90 Tanque - radiador dpu80/90	22
Rücklauffilter Return filter Filtro de retorno Filtre de retour	26
Kraftstofftank Kpl. DPU80/90 Fuel tank cpl. dpu80/90 Tanque de combustible cpl. dpu80/90 Reservoir de carburant cpl.	28
Hydraulikblock Kpl. DPU80r/90r/110r Block-hydraulic cpl. dpu80r/90r/110r Bloque hidráulico cpl. dpu80r/90r/110r Bloc hydraulique cpl.	30
Dieselmotor Kpl. DPU80/90 Diesel engine cpl. dpu80/90 Motor diesel cpl. dpu80/90 Moteur diesel cpl. dpu80/90	32
Halter Kpl. Holder cpl. Soporte cpl. Attache cpl.	36
Elektrobox Kpl. DPU80r/90r/110r Electric box cpl. dpu80r/90r/110r Caja eléctrica cpl. dpu80r/90r/110r Coffret électrique cpl.	38
Luftfilter Kpl. Air filter cpl. Filtro de aire cpl. Filtre à air cpl.	40

Verriegelung Hinten Kpl. Locking device rear cpl. Dispositivo de bloqueo atrás cpl. Dispositif de verrouillage	42
Batterie Kpl. Battery cpl. Bateria cpl. Batterie cpl.	44
Schutzrahmen Kpl. DPU80/90 Protective frame cpl. dpu80/90 Armazón de protección cpl. dpu80/90 Cadre protection cpl. dpu80/90	46
Haube Vorne Kpl. DPU80 Bonnet front cpl. dpu80 Cubierta delantero cpl. dpu80 Capot avant cpl. dpu80	48
Haube Hinten Kpl. DPU80 Bonnet rear cpl. dpu80 Cubierta atrás cpl. dpu80 Capot arrière cpl. dpu80	50
Sender Kpl. Transmitter cpl. Transmisor cpl. Transmetteur cpl.	52
Sender Transmitter Transmisor Transmetteur	54
Maschinenschutz Kpl. Overload sensor cpl. Sobrecarga sensor cpl. Surcharge capteur cpl.	56
Aufkleber Labels Calcomanías Autocollants	58
Motor DPU80 Engine dpu80 Motor dpu80 Moteur dpu80	
Kurbelwelle Crankshaft Cigueñal Vilebrequin	60
Kolben-Pleuel Piston-connecting rod Pistón-biela Piston-bielle	62

Schwungrad Fly wheel Volante Volant	64
Riemenscheibe V-belt pulley Polea Poulie	66
Kurbelgehäuse Crankcase Cárter Carter	68
Zylinderkopf Cylinder head Culata Culasse	72
Zylinderkopfdeckel Cylinder head cover Tapa del cilindro Couvercle supérieur	74
Einspritzanlage Injection system Sistema de inyección Équipement d' injection	76
Nockenwelle Camshaft Arbol de levas Arbre à cames	78
Kipphebel - Ventile Rocker arm - valve Balancín - válvula Culbuteur - soupape	80
Steuerriemen Timing belt Polea tensora de correa Tendeur de courroie	82
Ölpumpe Oil pump Bomba de aceite Pompe à huile	84
Ölwanne Oil pan Carter de aceite Cuvette carter à huile	86
Drehzahlregler Speed control module Controlador de velocidad Régulateur de vitesse	88

Steuerung Steering Dirección Direction	90
Kraftstoffpumpe Fuel pump Bomba de combustible Pompe à essence	92
Kraftstoffleitungen Fuel pipes Tubos de combustible Conduites de carburant	94
Thermostat Thermostat Termóstato Thermostat	96
Wasserpumpe Water pump Bomba de agua Pompe d'eau	98
Ansaugkrümmer Inlet bend Codo de aspiración Coude d'aspiration	100
Auspuffkrümmer Exhaust manifold Múltiple de escape Coude d'échappement	102
Generator Generator Generador Générateur	104
Anlasser Starter Starter Démarreur	106
Zündkerze Spark plug Bujía Bougie	108
Abdeckung Covering Cubierta Couverture	110





Untermasse Kpl. DPU80r/90r
Baseplate cpl. dpu80r/90r
Masa inferior cpl. dpu80r/90r
Masse inferieure cpl.

DPU80rLem670

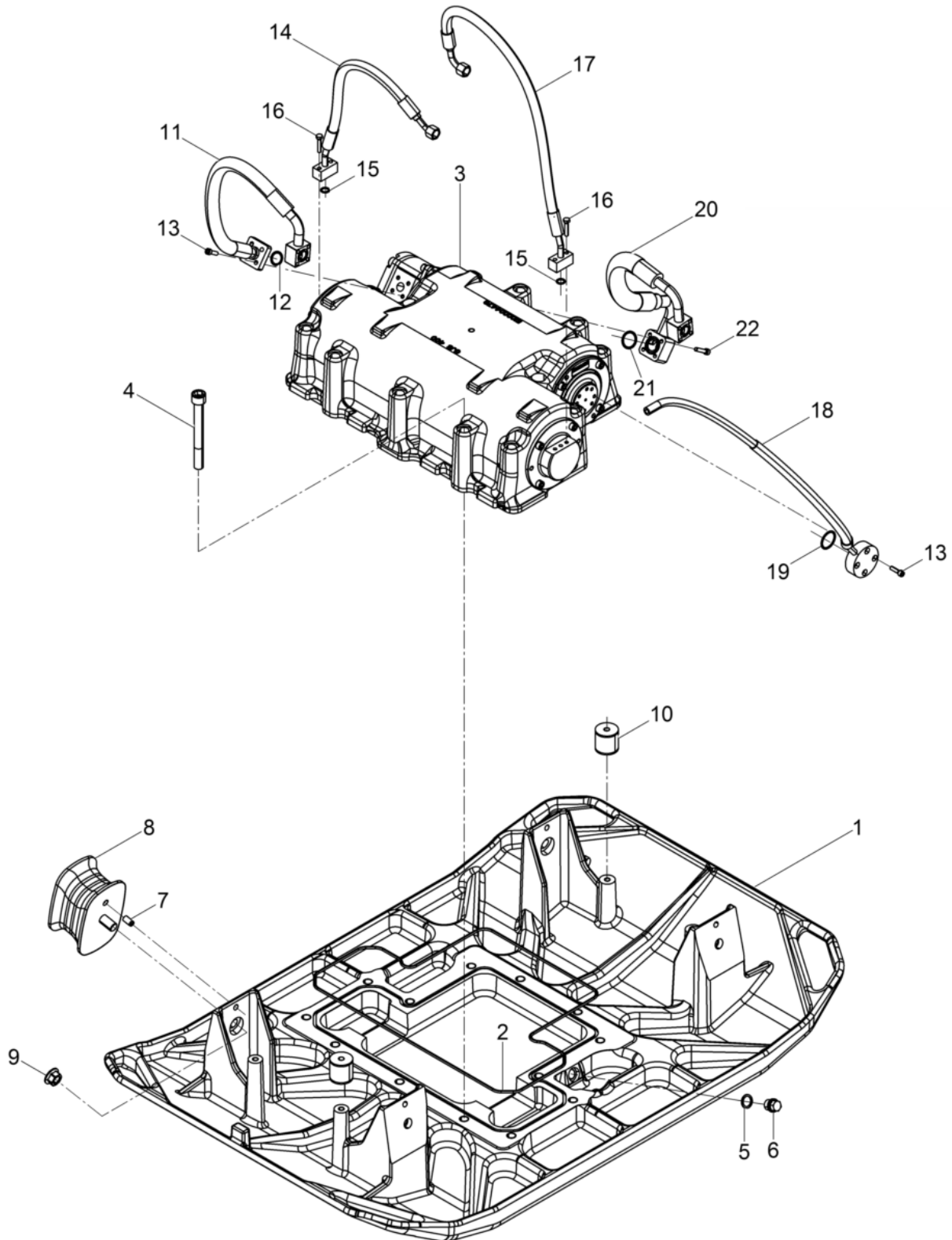

Pos. Item	Artikel Nr. Item no.	Pc.	Unit	Beschreibung Descripción	Description Description	Abm. Dim.	Norm Standard
						Drehmoment Torque	Schmierstoff Lubricant
1	5100009890	1	pc	Untermasse 770 Masa inferior 770	Baseplate 770 Masse inferieure 770		
1	5100009972	1	pc	Untermasse 670 Masa inferior 670	Baseplate 670 Masse inferieure 670		
2	5100005661	1	pc	O-Ring Anillo-o	O-ring Bague-o	494,00x4,00	
3	5100004545	1	pc	Erreger Kpl. (Dpu80r) Excitador cpl. (dpu80r)	Exciter cpl. (dpu80r) Excitateur cpl. (dpu80r)		
3	5100025626	1	pc	Erreger Kpl. (Dpu90r) Excitador cpl. (dpu90r)	Exciter cpl. (dpu90r) Excitateur cpl. (dpu90r)		
4	5100009777	13	pc	Zylinderschraube Tornillo cilíndrico	Cheese head screw Vis à tête cylindrique		
5	5000019156	1	pc	Dichtring Anillo de junta	Gasket Bague d'étanchéité		
6	5000068222	1	pc	Verschlusschraube Tapón roscado	Plug (threaded) Bouchon	100Nm/74ft.lbs	
7	5000203227	4	pc	Spannstift Pasador	Roll pin Goupille de tension		
8	5000216648	4	pc	Gummipuffer Bloque silente	Silent block Silentbloc		
9	5000212628	4	pc	Sicherungsmutter Contratuerca	Locknut Contre-écrou	210Nm/155ft.lbs	
10	5000216644	4	pc	Puffer Amortiguador	Shockmount Silentbloc	49Nm/36ft.lbs	
11	5100010249	1	pc	Schlauchleitung Conducto flexible	Hose pipe Conduite flexible		
12	5000210116	1	pc	O-Ring Anillo-o	O-ring Joint torique		
13	5000012373	8	pc	Zylinderschraube Tornillo cilíndrico	Cheese head screw Vis à tête cylindrique	10Nm/7ft.lbs	
14	5100010255	1	pc	Schlauchleitung Conducto flexible	Hose pipe Conduite flexible		
15	5100010591	2	pc	O-Ring Anillo-o	O-ring Bague-o	12,00x2,00	
16	5000011468	4	pc	Sechskantschraube Tornillo hexagonal	Hexagonal head cap screw Vis à tête hexagonale	M6 x 30 10Nm/7ft.lbs	DIN933
17	5100009970	1	pc	Schlauchleitung Conducto flexible	Hose pipe Conduite flexible	40Nm/30ft.lbs	
18	5100010160	1	pc	Entlüftungsleitung Línea de purgado	Breather tube Tuyau d'évacuation purge		
19	5100010115	1	pc	O-Ring Anillo-o	O-ring Bague-o		
20	5100010881	1	pc	Schlauchleitung Conducto flexible	Hose pipe Conduite flexible		
21	5000210115	1	pc	O-Ring Anillo-o	O-ring Joint torique		
22	5000011549	4	pc	Zylinderschraube Tornillo cilíndrico	Cheese head screw Vis à tête cylindrique	M6 x 30 10Nm/7ft.lbs	ISO4762

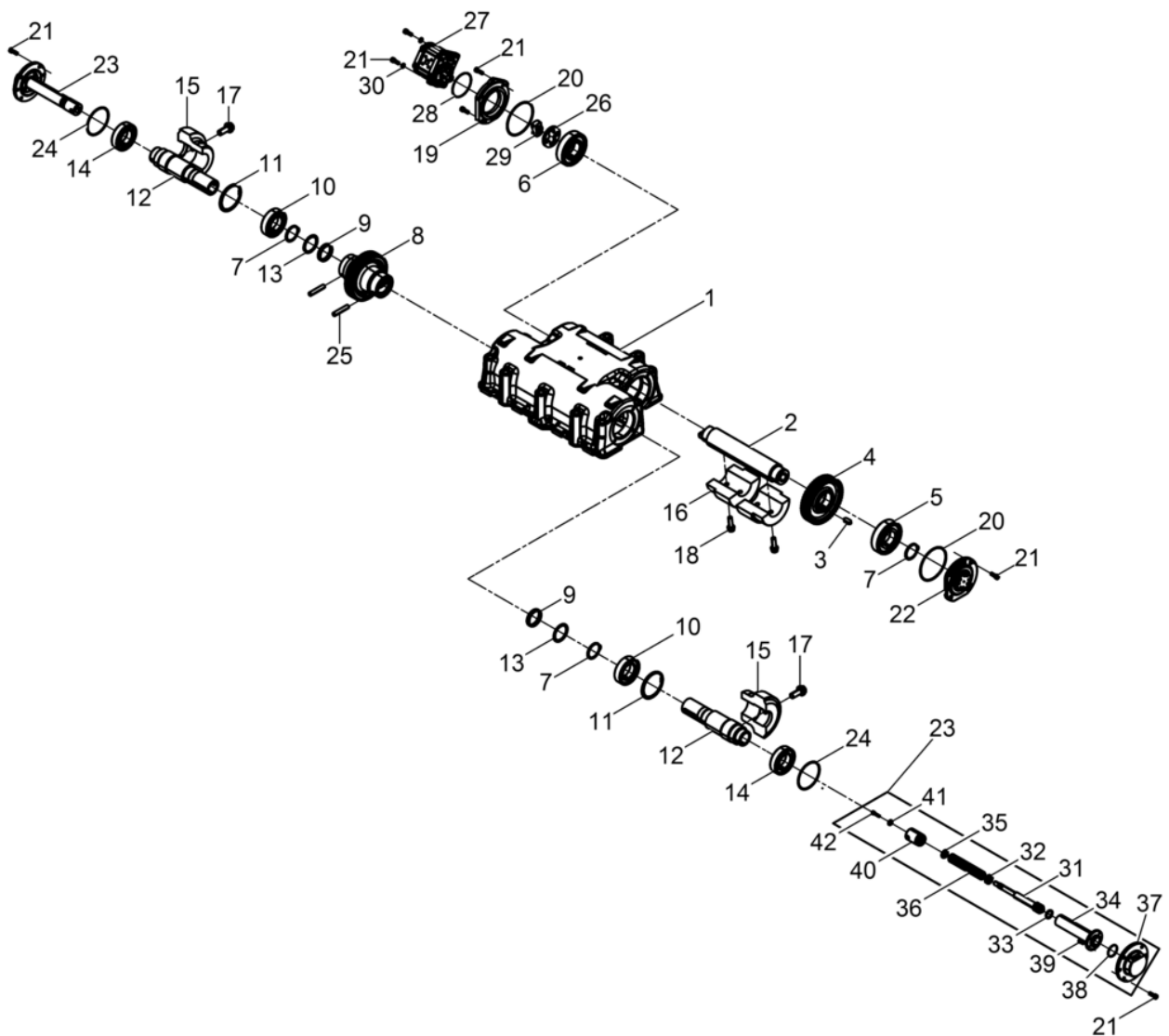

Pos. Item	Artikel Nr. Item no.	Pc.	Unit	Beschreibung Descripción	Description Description	Abm. Dim.	Norm Standard
						Drehmoment Torque	Schmierstoff Lubricant
1	5100004477	1	pc	Erregergehäuse Carcasa del excitador	Exciter housing Carter excitateur		
2	5100004298	1	pc	Antriebswelle Albero comando	Driving shaft Arbre d'entraînement		
3	5002006603	1	pc	Passfeder Chaveta	Fitting key Clavette		
4	5100004306	1	pc	Zahnrad Engranaje	Gear Engrenage		
5	5100010479	1	pc	Zylinderrollenlager Rodamiento cilíndricos	Cylindrical roller bearing Roulement à rouleaux cylindriq		
6	5100015097	1	pc	Zylinderrollenlager Rodamiento cilíndricos	Cylindrical roller bearing Roulement à rouleaux cylindriq		
7	5002006113	3	pc	Sicherungsring Anillo de retención	Retaining ring Bague d'arrêt		
8	5100005260	1	pc	Verstellhülse Husillo de regulación	Adjusting sleeve Douille de réglage		
9	5000206436	2	pc	Lagerbuchse Casquillo del cojinete	Bearing bush Boîte de roulement		
10	5100013880	2	pc	Zylinderrollenlager Rodamiento cilíndricos	Cylindrical roller bearing Roulement à rouleaux cylindriq		
11	5002007057	2	pc	Sicherungsring Anillo de retención	Retaining ring Bague d'arrêt	90 x 3	DIN472
12	5100004637	2	pc	Verstellwelle Árbol	Shaft Arbre		
13	5100017940	2	pc	Paßscheibe Arandela de ajuste	Shim ring Disque dajustage	50x 62x1,5	
14	5000103469	2	pc	Zylinderrollenlager Rodamiento cilíndricos	Cylindrical roller bearing Roulement à rouleaux		
15	5100018184	2	pc	Unwucht Masa excéntrica	Eccentric weight Balourd		
16	5100018185	2	pc	Unwucht Masa excéntrica	Eccentric weight Balourd		
17	5100005815	2	pc	Sicherungsschraube Tornillo	Corrugated-head screw Vis	M16x 40 330Nm/243ft.lbs	
18	5100005604	4	pc	Sicherungsschraube Tornillo	Corrugated-head screw Vis	150Nm/111ft.lbs	
19	5100005814	1	pc	Flansch Brida	Flange Bride		
20	5100005660	2	pc	O-Ring Anillo-o	O-ring Bague-o		
21	5000012629	20	pc	Zylinderschraube Tornillo cilíndrico	Cheese head screw Vis à tête cylindrique	25Nm/18ft.lbs	
22	5100004294	1	pc	Belüftungsdeckel Tapa de ventilación	Vent cover Couvercle d'aeration		
23	5100013846	2	pc	Verstellzylinder Kpl. Cilindro del ajuste cpl.	Adjustment cylinder cpl. Cylindre d'ajustement cpl.		
24	5100010516	2	pc	O-Ring Anillo-o	O-ring Bague-o	90,00x 3,00	
25	5000204527	2	pc	Schaltstift Espiga de mando	Tripping pin Broche de manoeuvre		
26	5100003535	1	pc	Kreuzscheibe Disco	Disc Disque		
27	5100005740	1	pc	Zahnradmotor Links Bomba de engranajes izquierda	Gear pump left Pompe d'engrenages gauche		
28	5100004118	1	pc	O-Ring Anillo-o	O-ring Bague-o		

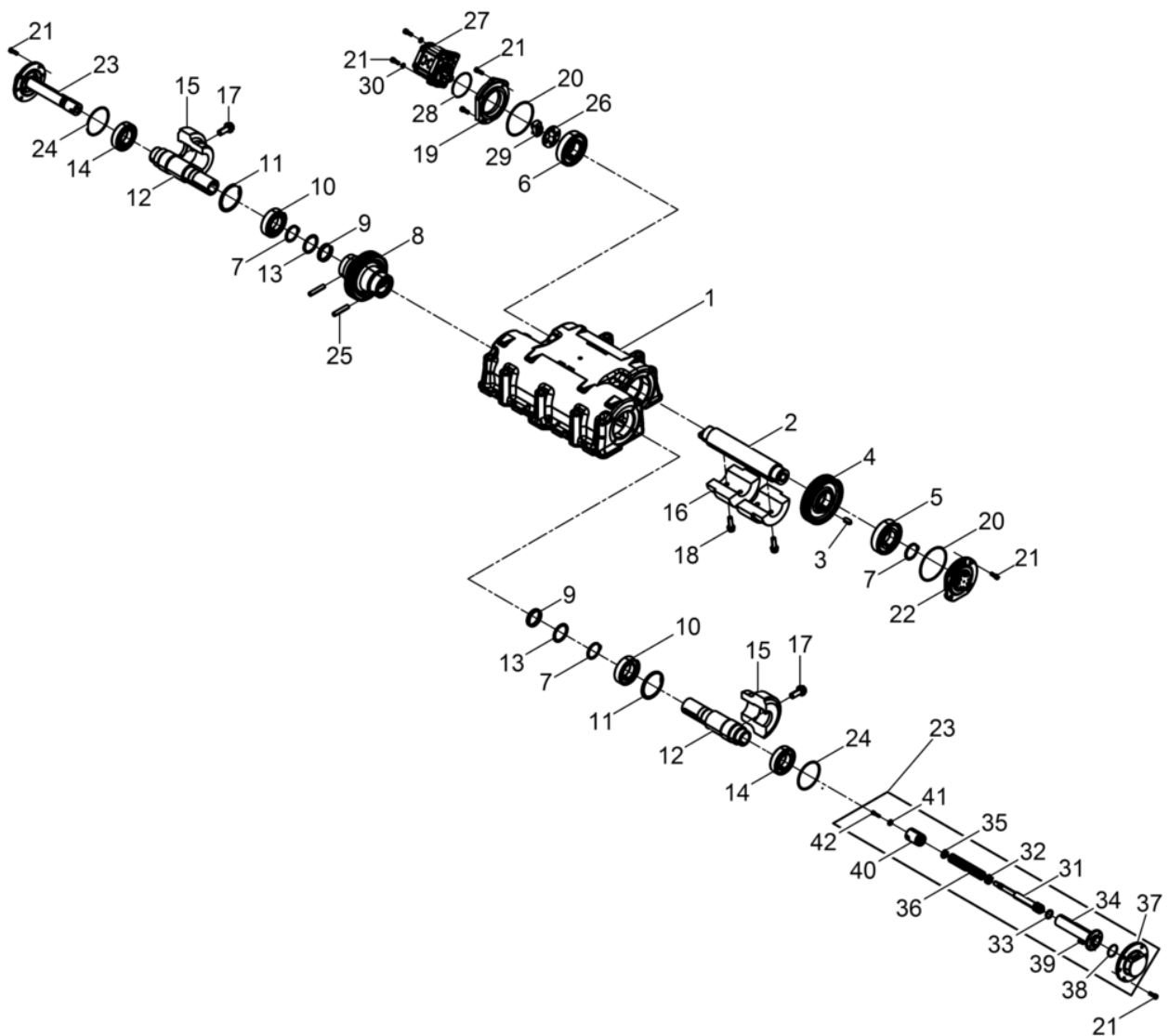

Pos. Item	Artikel Nr. Item no.	Pc.	Unit	Beschreibung Descripción	Description Description	Abm. Dim.	Norm Standard
						Drehmoment Torque	Schmierstoff Lubricant
29	5100003696	1	pc	Mitnehmer Arrastrador	Carrier Levier d'entrainement		
30	5000010742	4	pc	Scheibe Arandela	Washer Rondelle		
31	5100005511	2	pc	Kolben Pistón	Piston Piston		
32	5100005971	2	pc	Nutring Anillo ranurado	Grooved ring Joint à levres	18x28x8	
33	5100005972	2	pc	Führungsring Anillo guía	Guide ring Bague de guidage		
34	5100005508	2	pc	Zylinderrohr Tubo	Pipe Tube		
35	5100005840	2	pc	Anschlagscheibe Disco de tope	Stop disc Rondelle de butée		
36	5100005921	2	pc	Druckfeder Resorte de compresión	Compression spring Ressort de pression		
37	5100005507	2	pc	Zylinderdeckel Tapa del cilindro	Cylinder cover Couvercle de cylindre		
38	5100005970	2	pc	O-Ring Anillo-o	O-ring Bague-o	38,00x2,00 10Nm/7ft.lbs	
39	5000043307	10	pc	Zylinderschraube Tornillo cilíndrico	Cheese head screw Vis à tête cylindrique	M5 x 12 10Nm/7ft.lbs	ISO4762
40	5100016693	2	pc	Kolben Kpl. Pistón cpl.	Piston cpl. Piston cpl.		
41	5000124717	2	pc	Scheibe Arandela	Washer Rondelle	17.8Nm/13ft.lbs	
42	5000220001	2	pc	Zylinderschraube Tornillo cilíndrico	Cheese head screw Vis à tête cylindrique	17.8Nm/13ft.lbs	

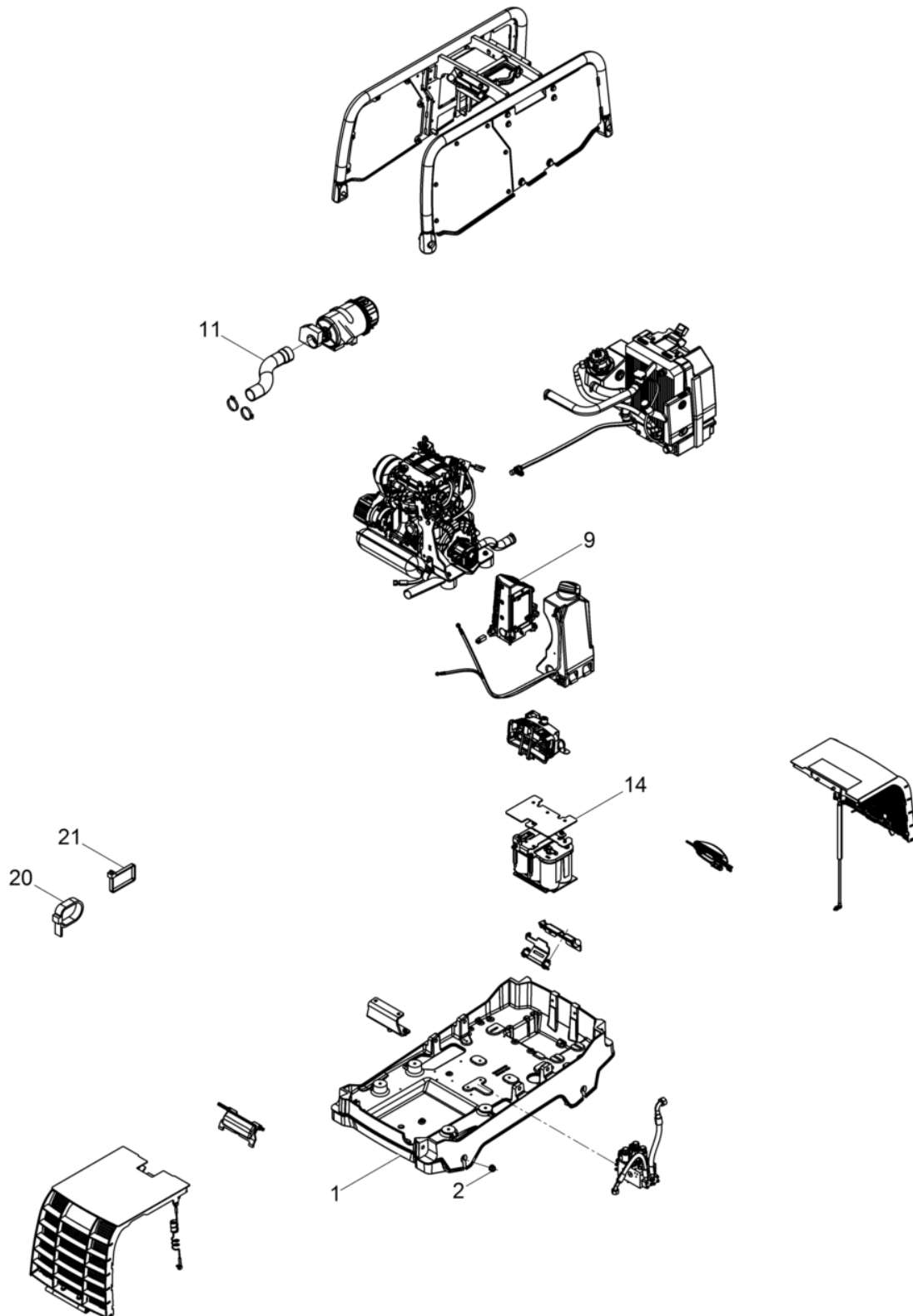

Pos. Item	Artikel Nr. Item no.	Pc.	Unit	Beschreibung Descripción	Description Description	Abm. Dim.	Norm Standard
						Drehmoment Torque	Schmierstoff Lubricant
1	5100004991	1	pc	Obermasse Masa superior	Upper mass Masse superieure		
2	5000212628	4	pc	Sicherungsmutter Contratuerca	Locknut Contre-écrou	210Nm/155ft.lbs	
9	5100013831	1	pc	Elektrobox Kpl. Caja eléctrica cpl.	Electric box cpl. Coffret électrique cpl.		
14	5100005939	1	pc	Schutzlappen Trapo de protección	Protective cloth Protection		
20	5000047388	20	pc	Kabelbinder Fijación de cables	Zip tie Attache de câble		
21	5000038489	10	pc	Kabelbinder Fijación	Tie cable Attache		

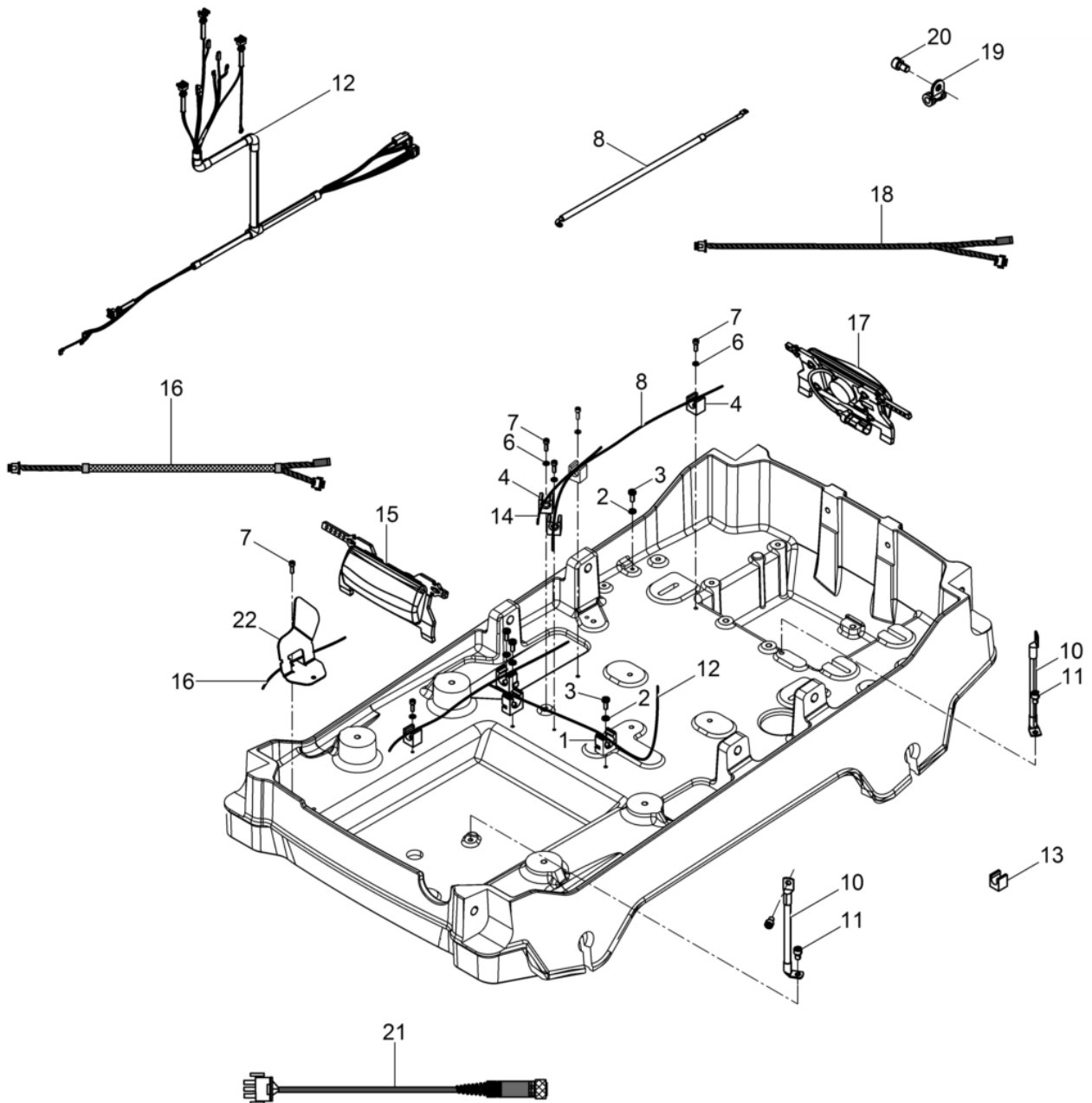

Pos. Item	Artikel Nr. Item no.	Pc.	Unit	Beschreibung Descripción	Description Description	Abm. Dim.	Norm Standard
						Drehmoment Torque	Schmierstoff Lubricant
1	5000210107	3	pc	Schlauchklemme Abrazadera	Clamp Collier de serrage		
2	5000010624	4	pc	Scheibe Arandela	Flat washer Rondelle		
3	5000211755	4	pc	Schraube Tornillo	Screw Vis		
4	5100010281	5	pc	Schlauchklemme Abrazadera	Clamp Collier de serrage		
6	5000010625	5	pc	Scheibe Arandela	Flat washer Rondelle		
7	5000011561	6	pc	Zylinderschraube Tornillo cilíndrico	Cheese head screw Vis à tête cylindrique		
8	5100005670	1	pc	Plus-Pol-Leitung Cable positivo	Positive cable Positive cable		
10	5100010152	2	pc	Minus-Pol-Leitung Cable polo negativo	Negative pole strap Ligne borne négative		
11	5000013574	3	pc	Zylinderschraube Tornillo cilíndrico	Cheese head screw Vis à tête cylindrique	25Nm/18ft.lbs	
12	5100010130	1	pc	Kabelbaum Motor Disp. del cable de elevación motor	Cable harness engine Faisceau de câbles moteur		
13	5100017849	1	pc	Klebeschelle Abrazadera	Clamp Collier		
14	5100005665	1	pc	Kabelbaum Ventil Disp. del cable de elevación válvula	Cable harness valve Faisceau de câbles soupape		
15	5100011350	1	pc	Empfangseinheit Vorne Unidad del receptor delantero	Receiver unit front Unité de récepteur avant		
16	5100005668	1	pc	Kabelbaum Empfangseinheit Vor- Ne Disp. del cable de elevación unidad del receptor delantero	Cable harness receiver unit front Faisceau de câbles		
17	5100011351	1	pc	Empfangseinheit Hinten Unidad del receptor atrás	Receiver unit rear Unité de récepteur arrière		
18	5100005667	1	pc	Kabelbaum Empfangseinheit Hin- Ten Disp. del cable de elevación unidad del receptor atrás	Cable harnessreceiver unit rear Faisceau de câbles		
19	5000212143	1	pc	Rohrschelle Abrazadera	Clamp Agrafe	RSGU 1.6/15	
20	5000011555	1	pc	Zylinderschraube Tornillo cilíndrico	Cheese head screw Vis à tête cylindrique	M6 x 10 10Nm/7ft.lbs	ISO4762
21	5100010511	1	pc	Ladekabel Cable de carga	Charging cable Câble de charge		
22	5100027457	1	pc	Hitzeschild Pantalla térmica	Heat shield Écran thermique		

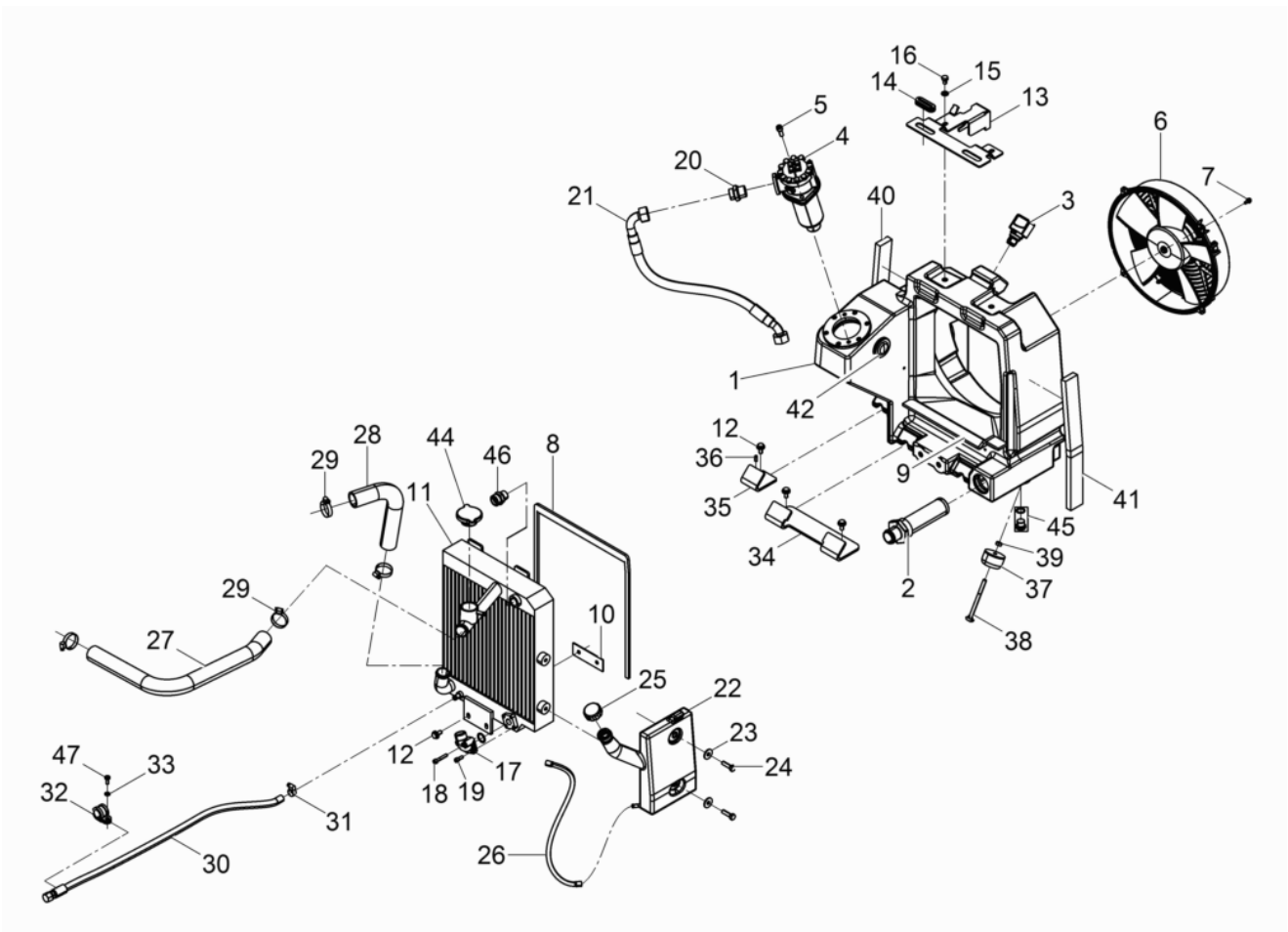

Pos. Item	Artikel Nr. Item no.	Pc.	Unit	Beschreibung Descripción	Description Description	Abm. Dim.	Norm Standard
						Drehmoment Torque	Schmierstoff Lubricant
1	5100005488	1	pc	Hydrauliktank Tanque hidráulico	Hydraulic tank Réservoir hydraulique		
2	5100010301	1	pc	Filterelement Elemento del filtro	Filter element Élément du filtre		
3	5100010303	1	pc	Filterelement Elemento del filtro	Filter element Élément du filtre		
4	5100010302	1	pc	Rücklaufilter Filtro de retorno	Return filter Filtre de retour		
5	5000012629	2	pc	Zylinderschraube Tornillo cilíndrico	Cheese head screw Vis à tête cylindrique	25Nm/18ft.lbs	
6	5100010341	1	pc	Elektrolüfter Ventilador	Fan Ventilateur		
7	5100015757	4	pc	Sechskantschraube Tornillo hexagonal	Hexagonal head cap screw Vis à tête hexagonale		
8	5100016476	1	pc	Dichtung Junta	Gasket Joint		
9	5100016478	1	pc	Dichtung Junta	Gasket Joint		
10	5100015887	1	pc	Blech Chapa	Plate Tôle		
11	5100005489	1	pc	Kühler Radiador	Radiator Radiateur		
12	5000211795	5	pc	Sicherungsschraube Tornillo	Corrugated-head screw Vis		
13	5100014130	1	pc	Halter Soporte	Bracket Support		
14	5100010830	2	pc	Durchführungsstülpe Boquilla de paso	Cable passage Douille de passage		
15	5000010622	2	pc	Scheibe Arandela	Flat washer Rondelle		
16	5000012360	2	pc	Sechskantschraube Tornillo hexagonal	Hexagonal head cap screw Vis à tête hexagonale	25Nm/18ft.lbs	
17	5100010161	1	pc	Winkelflanschverschraubung Atornilladura	Bolted connection Fixation à bride angulaire		
18	5000011548	2	pc	Zylinderschraube Tornillo cilíndrico	Cheese head screw Vis à tête cylindrique	10Nm/7ft.lbs	
19	5000011553	2	pc	Zylinderschraube Tornillo cilíndrico	Cheese head screw Vis à tête cylindrique	10Nm/7ft.lbs	
20	5100011096	1	pc	Einschraubstutzen Empalme roscado	Screwed socket Manchon visse		
21	5100010252	1	pc	Schlauchleitung Conducto flexible	Hose pipe Conduite flexible		
22	5100009849	1	pc	Überlaufflasche Botella de rebose	Bottle-overflow Bouteille de trop-plein		
23	5000010374	2	pc	Scheibe Arandela	Flat washer Rondelle		
24	5000011456	2	pc	Sechskantschraube Tornillo hexagonal	Hexagonal head cap screw Vis à tête hexagonale	25Nm/18ft.lbs	
25	5100015982	1	pc	Deckel Tapa	Cover Couvercle		
26	5100015647	1	pc	Kühlerschlauch Manguera de combustible	Radiator hose Tuyau à essence		
27	5100010313	1	pc	Wasserschlauch Manguera de agua	Water hose Tuyau d'eau		
28	5100006059	1	pc	Wasserschlauch Manguera de agua	Water hose Tuyau d'eau		

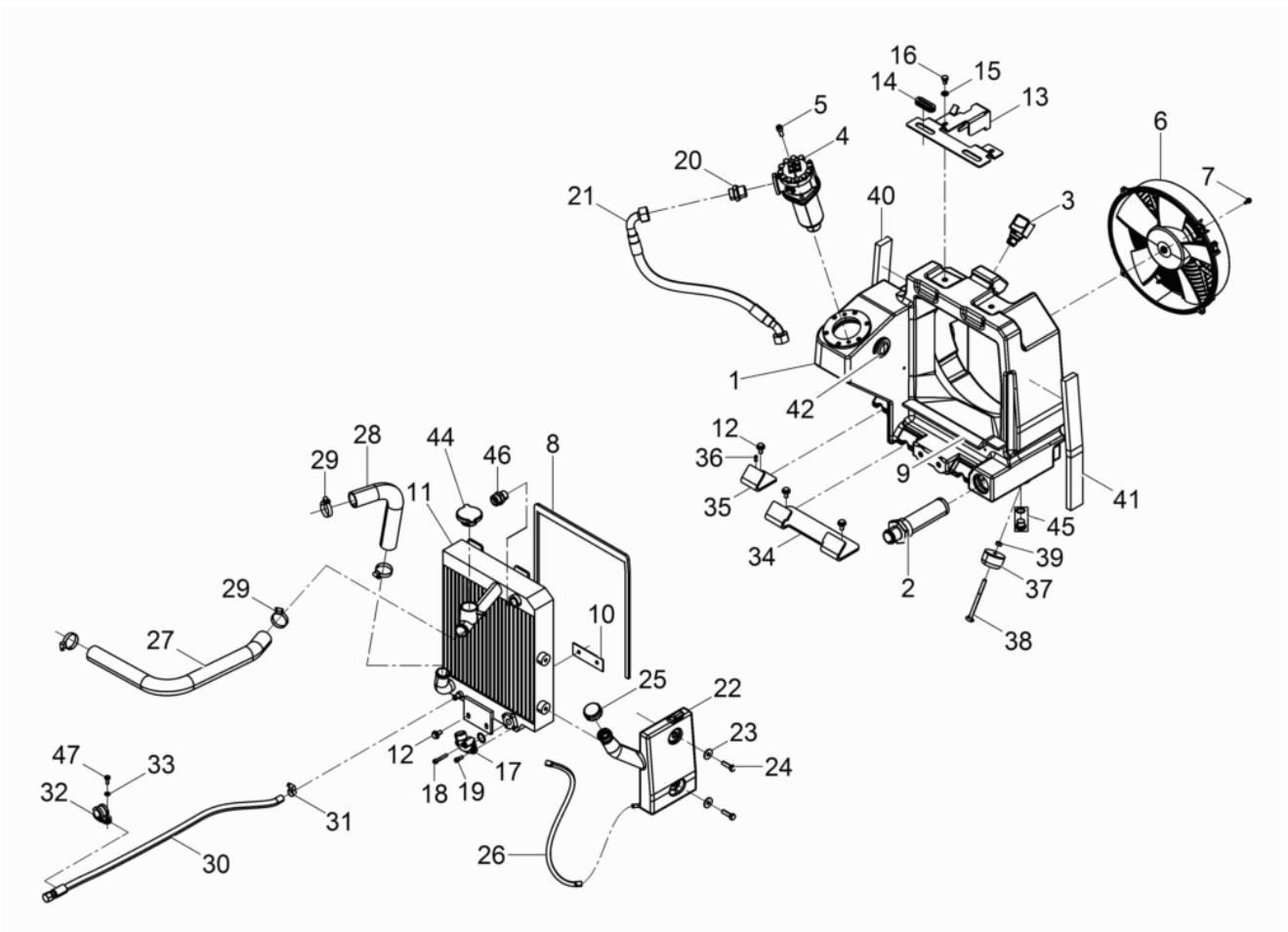

Pos. Item	Artikel Nr. Item no.	Pc.	Unit	Beschreibung Descripción	Description Description	Abm. Dim.	Norm Standard
						Drehmoment Torque	Schmierstoff Lubricant
29	5002004724	4	pc	Schneckenwindeschelle Abrazadera con sinfín	Worm drive house clip Collier de serrage		
30	5100010256	1	pc	Schlauchleitung Kpl. Conducto flexible cpl.	Hose pipe cpl. Conduite flexible cpl.		
31	5000016836	1	pc	Schneckenwindeschelle Abrazadera	Clamp Agrafe		
32	5000206551	1	pc	Rohrschelle Abrazadera	Clamp Agrafe		
33	5000010624	1	pc	Scheibe Arandela	Flat washer Rondelle		
34	5100010567	1	pc	Halter Soporte	Bracket Support		
35	5100010568	1	pc	Halter Soporte	Bracket Support		
36	5000097656	1	pc	Spannstift Pasador	Roll pin Goupille de tension		
37	5100009991	2	pc	Gummipuffer Tope caucho-metal	Shockmount Tampon oscillant		
38	5100015096	2	pc	Hammerschraube M. Nase Tornillo con cabeza demartillo	Hammer head bolt Vis à tête rectangulaire		
39	5000010882	2	pc	Sechskantmutter Tuerca hexagonal	Hexagon nut Écrou hexagonal		
40	5100016491	1	pc	Dichtung Junta	Gasket Joint		
41	5100016492	1	pc	Dichtung Junta	Gasket Joint		
42	1000262373	1	pc	Schauglas Cristal de observación	View glass Jauge de niveau		
44	5100011421	1	pc	Deckel (Bajonettverschluss) Tapa (cierre de bayoneta)	Cover (bayonet lock) Couvercle (fermeture à baïonnette)		
45	5100015762	1	pc	Verschlusschraube Tapón roscado	Plug (threaded) Bouchon		
46	5000063739	1	pc	Einschraubstutzen Empalme roscado	Screwed socket Manchon visse		DIN3901
47	5000211755	1	pc	Schraube Tornillo	Screw Vis		

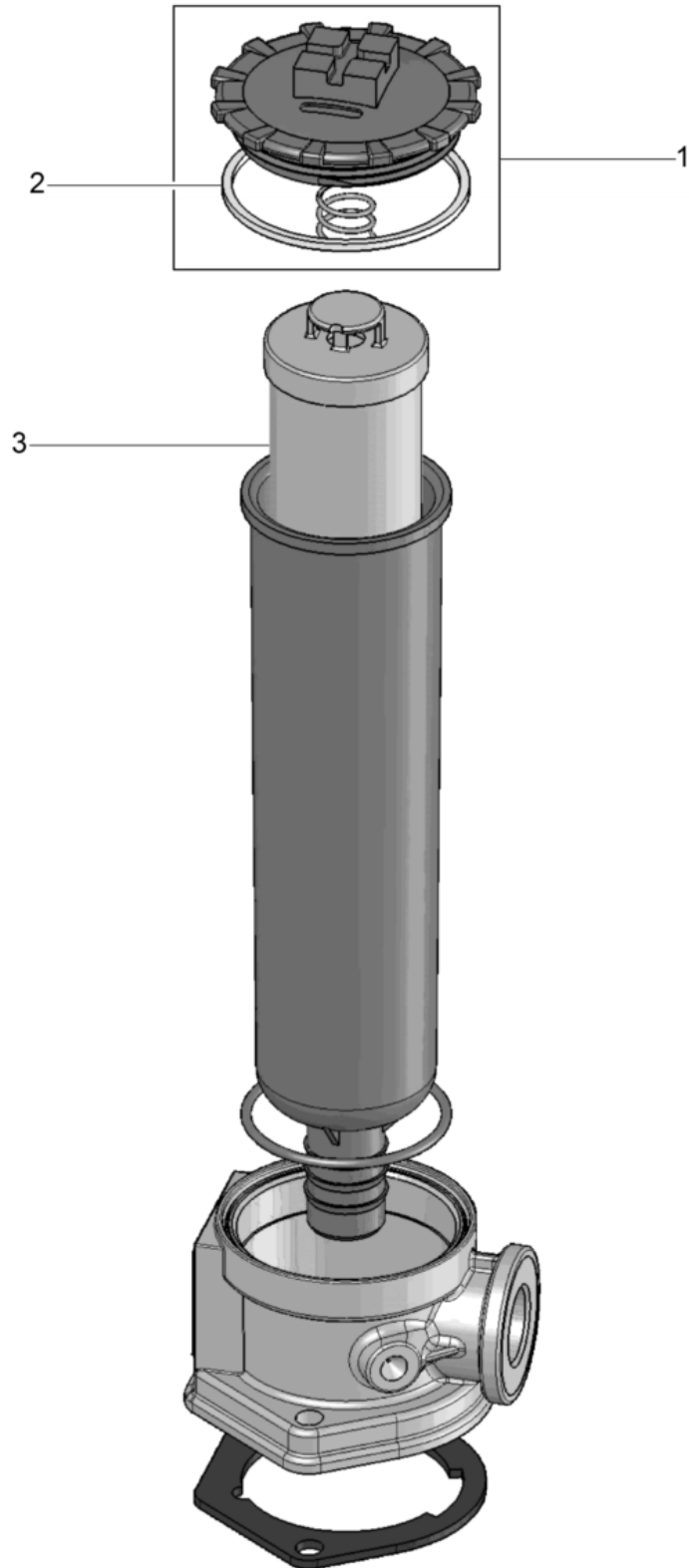

Pos. Item	Artikel Nr. Item no.	Pc.	Unit	Beschreibung Descripción	Description Description	Abm. Dim.	Norm Standard
						Drehmoment Torque	Schmierstoff Lubricant
1	5000220217	1	pc	Deckel Kpl. Tapa	Cover Couvercle		
2	5000220218	1	pc	Dichtung Junta de estanqueidad	Gasket Garniture		
3	5100016998	1	pc	Filterelement Elemento del filtro	Filter element Élément du filtre		

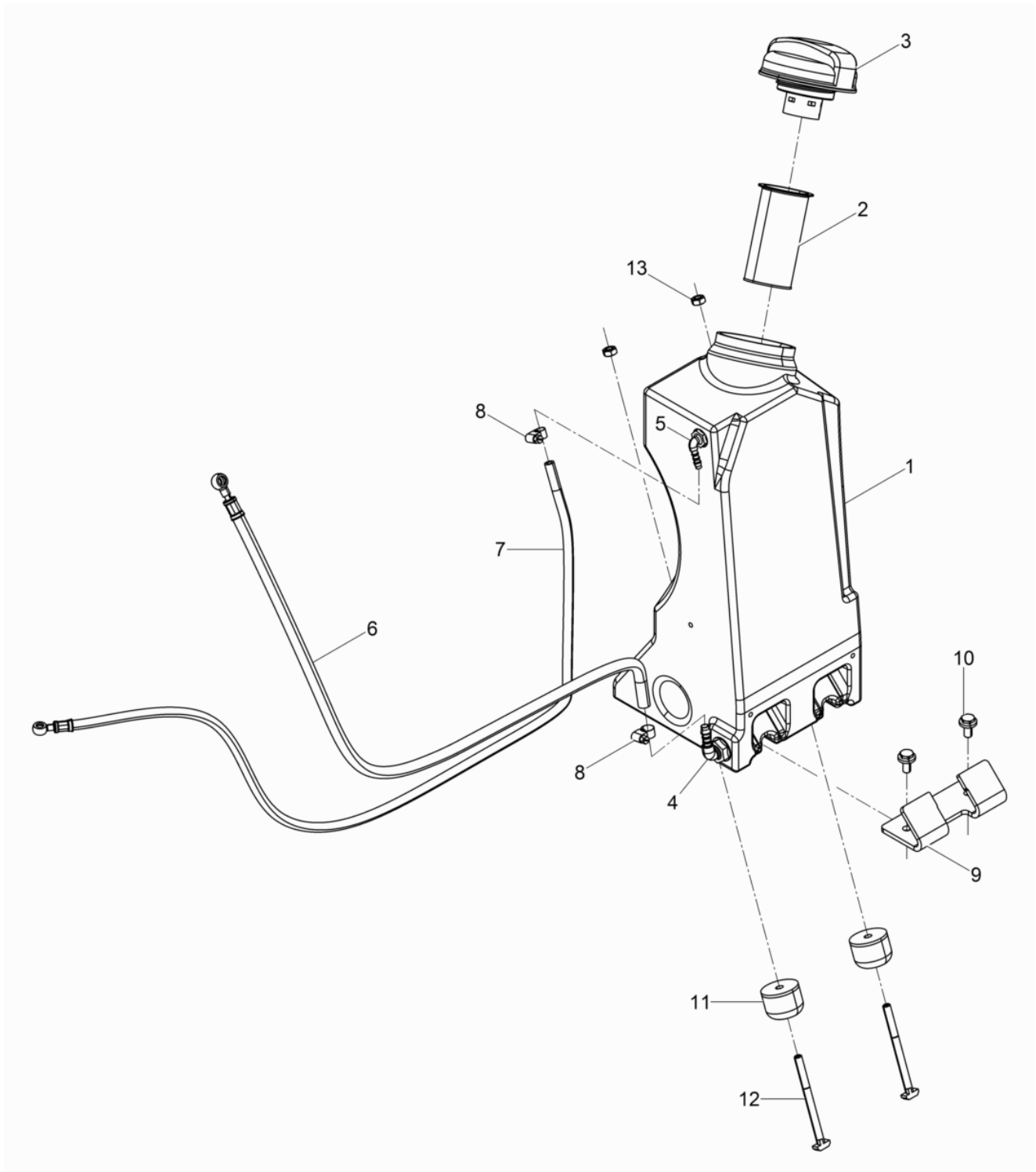

Pos. Item	Artikel Nr. Item no.	Pc.	Unit	Beschreibung Descripción	Description Description	Abm. Dim.	Norm Standard
						Drehmoment Torque	Schmierstoff Lubricant
1	5100038140	1	pc	Kraftstofftank Depósito de combustible	Fuel tank Réservoir à essence		
2	1000267866	1	pc	Einfüllsieb Criba de llenado	Screen Crible		
3	5100010476	1	pc	Tankdeckel Tapa de tanque	Tank cover Couvercle du réservoir	3Nm/2ft.lbs	
4	1000051394	1	pc	Winkelstützen Tubuladura angular	Angle cut piece Tubulure d'angle		
5	5100010035	1	pc	Winkelstützen Kpl. Tubuladura angular cpl.	Elbow fitting cpl. Raccord cpl.		
6	5100010244	1	pc	Kraftstoffleitung Manguera de combustible	Fuel hose Tuyau à essence		
7	5100010245	1	pc	Kraftstoffleitung Manguera de combustible	Fuel hose Tuyau à essence		
8	5000016836	2	pc	Schneckenwindeschelle Abrazadera	Clamp Agrafe		
9	5100010569	1	pc	Halter Soporte	Bracket Support		
10	5000211795	2	pc	Sicherungsschraube Tornillo	Corrugated-head screw Vis	35Nm/26ft.lbs	
11	5100009992	2	pc	Gummipuffer Tope caucho-metal	Shockmount Tampon oscillant		
12	5100015096	2	pc	Hammerschraube M. Nase Tornillo con cabeza demartillo	Hammer head bolt Vis à tête rectangulaire		
13	5000010882	2	pc	Sechskantmutter Tuerca hexagonal	Hexagon nut Écrou hexagonal	6Nm/4ft.lbs	

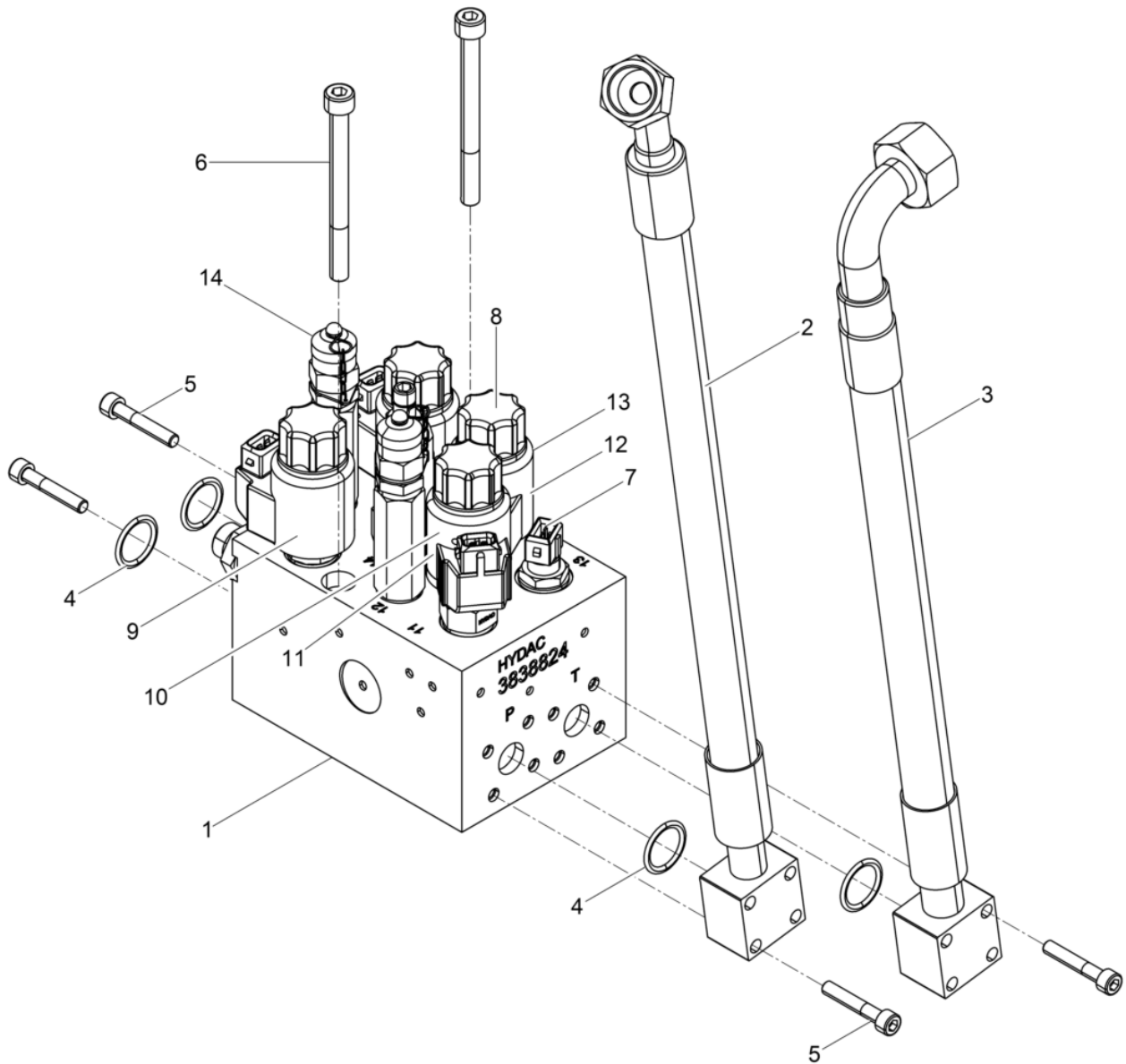

Pos. Item	Artikel Nr. Item no.	Pc.	Unit	Beschreibung Descripción	Description Description	Abm. Dim.	Norm Standard
						Drehmoment Torque	Schmierstoff Lubricant
1	5100005966	1	pc	Hydraulikblock Bloque hidráulico	Block-hydraulic Bloc hydraulique		
2	5100010247	1	pc	Schlauchleitung Conducto flexible	Hose pipe Conduite flexible		
3	5100010251	1	pc	Schlauchleitung Conducto flexible	Hose pipe Conduite flexible		
4	5000210116	4	pc	O-Ring Anillo-o	O-ring Joint torique		
5	5000011548	16	pc	Zylinderschraube Tornillo cilíndrico	Cheese head screw Vis à tête cylindrique	10Nm/7ft.lbs	
6	5000058705	2	pc	Zylinderschraube Tornillo cilíndrico	Cheese head screw Vis à tête cylindrique	M8 x 90 25Nm/18ft.lbs	ISO4762
7	5100005738	1	pc	Temperaturfühler Elemento térmico	Temperature sensor Décteur thermique		
8	5000220194	4	pc	Ventilkappe Casquete de válvula	Valve cap Joint de soupape		
9	5100025064	2	pc	Ventil Válvula	Valve Soupape		
10	5100025061	1	pc	Ventil Válvula	Valve Soupape		
11	5100025062	1	pc	Magnetspule Solenoid	Solenoid Solénoide		
12	5100025063	1	pc	Ventil Válvula	Valve Soupape		
13	5000220193	3	pc	Magnetspule Solenoid	Solenoid Solénoide		
14	5000220198	2	pc	Messanschluss Conexión de medición	Test port Raccordement		

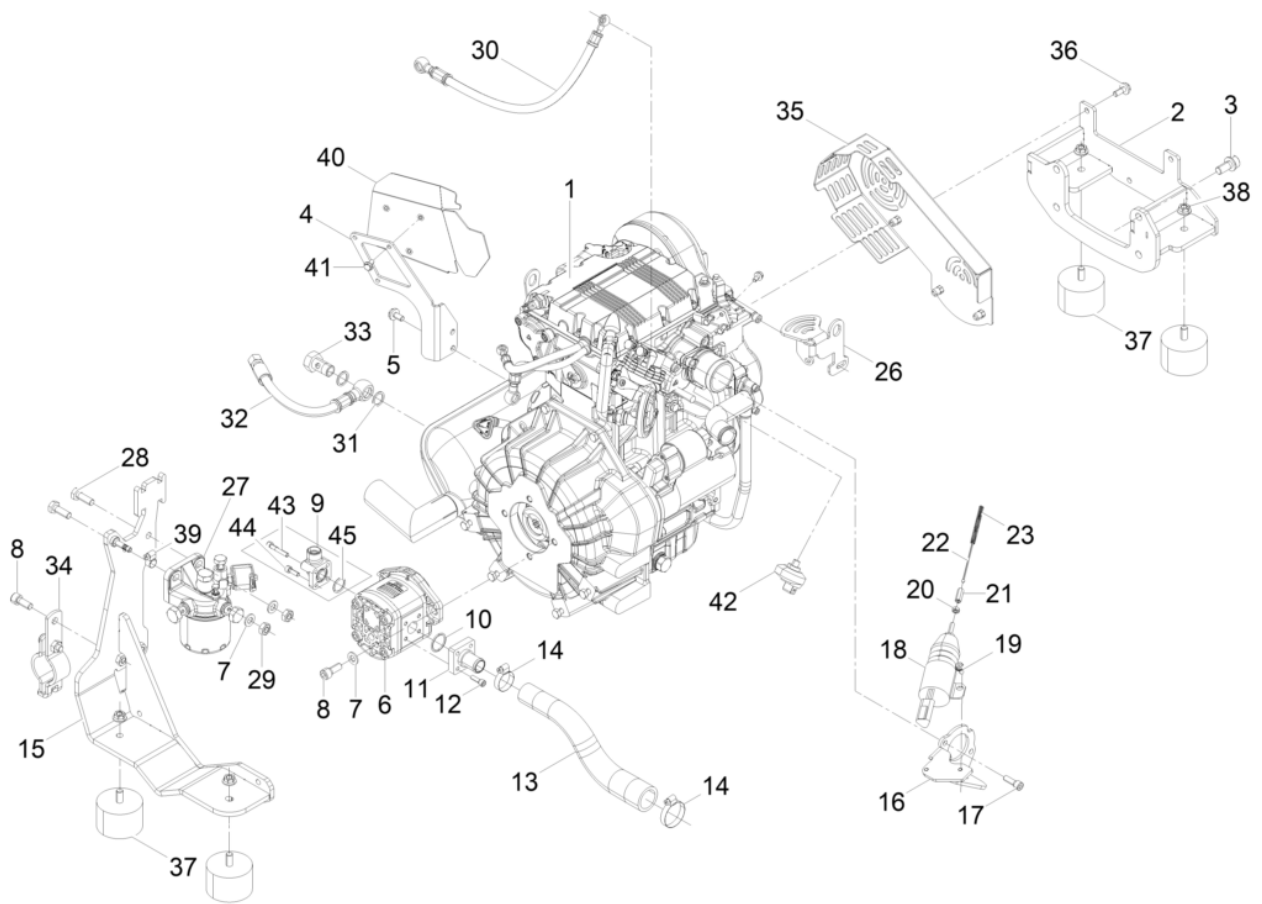

Pos. Item	Artikel Nr. Item no.	Pc.	Unit	Beschreibung Descripción	Description Description	Abm. Dim.	Norm Standard
						Drehmoment Torque	Schmierstoff Lubricant
1	5100024723	1	pc	Dieselmotor KDW 702 - 3350 US (DPU90 US) Motor diesel kdw 702 - 3350 us (dpu90 us)	Diesel engine kdw 702 - 3350 us (dpu90 us) Moteur diesel kdw 702 - 3350 u		
1	5100049016	1	pc	Dieselmotor Motor diesel	Diesel engine Moteur diesel		
1	5100049017	1	pc	Dieselmotor Motor diesel	Diesel engine Moteur diesel		
2	5100005758	1	pc	Motorträger Kpl. Montaje del motor cpl.	Engine support cpl. Montage du moteur cpl.		
3	5000210165	4	pc	Sicherungsschraube Tornillo	Corrugated-head screw Vis		
4	5100011317	1	pc	Halter Soporte	Bracket Support		
5	5000211795	2	pc	Sicherungsschraube Tornillo	Corrugated-head screw Vis		
6	5100005655	1	pc	Zahnradpumpe Bomba de engranajes	Gear pump Pompe d'engrenages		
7	5000010621	4	pc	Scheibe Arandela	Flat washer Rondelle		
8	5000011535	3	pc	Zylinderschraube Tornillo cilíndrico	Cheese head screw Vis à tête cylindrique	49Nm/36ft.lbs	
9	5100046101	1	pc	Winkel-Flanschverschraubung Kp Atornilladura cpl.	Bolted connection cpl. Fixation à bride angulaire cpl		
10	5000210115	1	pc	O-Ring Anillo-o	O-ring Joint torique		
11	5100010059	1	pc	Schlauchstutzen Racord de manguera	Hose connection Bride d'aspiration		
12	5000011551	4	pc	Zylinderschraube Tornillo cilíndrico	Cheese head screw Vis à tête cylindrique	10Nm/7ft.lbs	
13	5100010056	1	pc	Ansaugschlauch Manguera de succión	Suction hose Tuyau de succion		
14	5002004724	2	pc	Schneckenwindeschelle Abrazadera con sinfín	Worm drive house clip Collier de serrage		
15	5100005748	1	pc	Motorträger Kpl. Montaje del motor cpl.	Engine support cpl. Montage du moteur cpl.		
16	5100005769	1	pc	Blech Chapa	Plate Tôle		
17	5000011542	2	pc	Zylinderschraube Tornillo cilíndrico	Cheese head screw Vis à tête cylindrique	25Nm/18ft.lbs	
18	5000155486	1	pc	Gasreglerstellteil Actuador de acelerador	Throttle actuator Dispositif de commande des gaz		
19	5100010512	3	pc	Sicherungsschraube Tornillo	Corrugated-head screw Vis		
20	5000010880	1	pc	Sechskantmutter Tuerca hexagonal	Hexagon nut Écrou hexagonal		
21	5000155487	1	pc	Adapter Adaptador	Adaptor Adaptateur		
22	5000150022	1	pc	Kabel Cable	Cable Câble		
23	5100010831	1	pc	Druckfeder Resorte de compresión	Compression spring Ressort de pression		
26	5100010901	1	pc	Abdeckung Cubierta	Covering Cubierta		
27	5000210173	1	pc	Kraftstofffilter Kpl. Filtro de combustible cpl.	Filter-fuel cpl. Re à carburant cpl.		
27	5000215484	1	pc	Kraftstofffilter Filtro de combustible	Fuel filter Filtre à carburant		

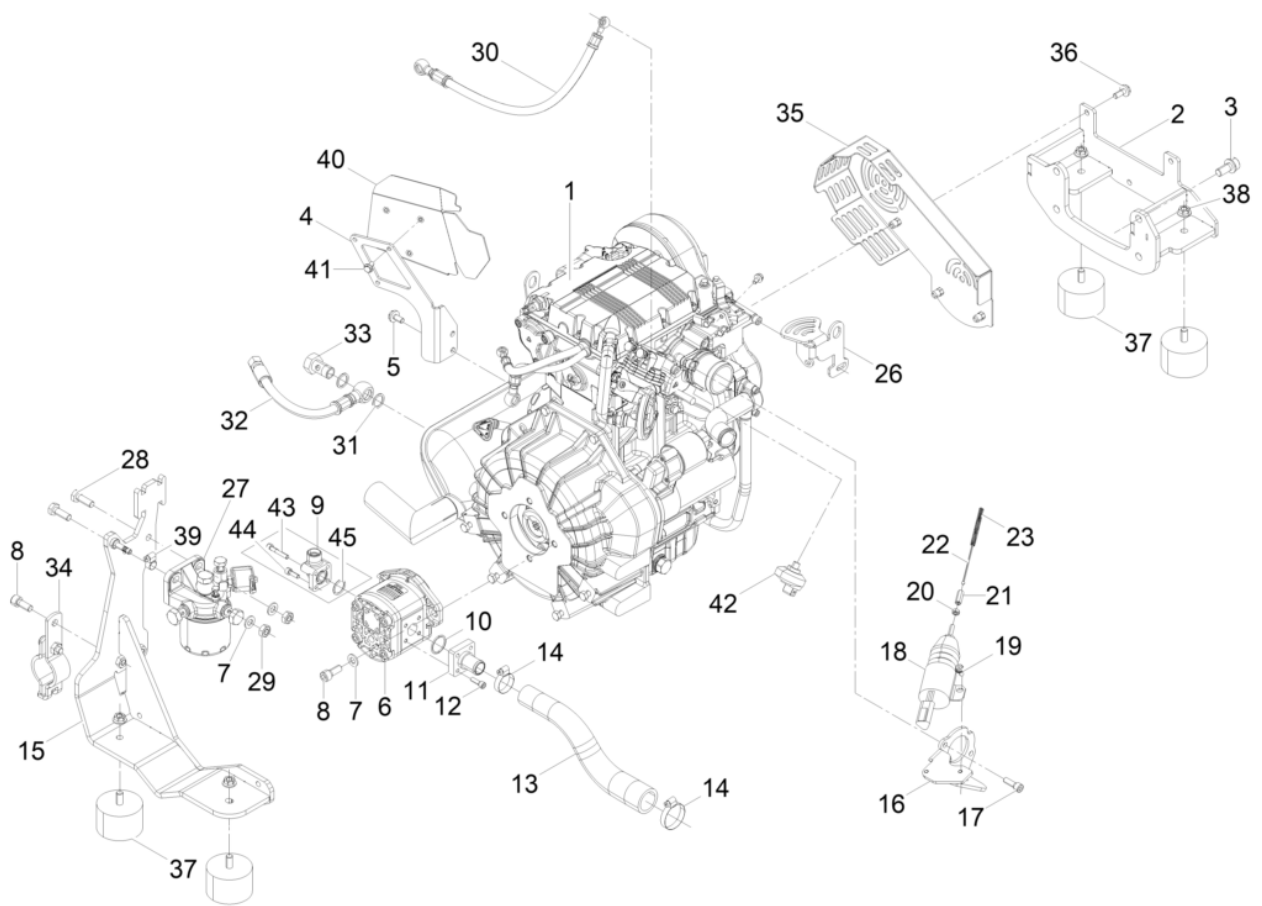

Pos. Item	Artikel Nr. Item no.	Pc.	Unit	Beschreibung Descripción	Description Description	Abm. Dim.	Norm Standard
						Drehmoment Torque	Schmierstoff Lubricant
28	5000011439	2	pc	Sechskantschraube Tornillo hexagonal	Hexagonal head cap screw Vis à tête hexagonale	49Nm/36ft.lbs	
29	5000010883	2	pc	Sechskantmutter Tuerca hexagonal	Hexagon nut Écrou hexagonal		
30	5100010246	1	pc	Kraftstoffleitung Manguera de combustible	Fuel hose Tuyau à essence		
31	5000019156	2	pc	Dichtring Anillo de junta	Gasket Bague d'étanchéité		
32	5100010257	1	pc	Schlauchleitung Conducto flexible	Hose pipe Conduite flexible		
33	5000207336	1	pc	Hohlschraube Tornillo hueco	Hollow screw Boulon creux à filet femelle		
34	5100011327	1	pc	Rohrschelle Abrazadera	Pipe clamp Collier pour tuyau		
35	5100010740	1	pc	Keilriemenschutz Kpl. Protección de la polea cpl.	Belt guard cpl. Protection de courroie cpl.		
36	5100018058	4	pc	Sicherungsschraube Tornillo de seguridad	Corrugated-head screw Vis de sécurité		
37	5100000973	4	pc	Gummi-Metall-Puffer Amortiguador	Shockmount Silentbloc		
38	5000216640	4	pc	Sicherungsmutter Contratuerca	Locknut Contre-écrou		
39	5000016836	1	pc	Schneckenwindeschelle Abrazadera	Clamp Agrafe		
40	5100024279	1	pc	Hitzeschild Kpl. Pantalla térmica cpl.	Heat shield cpl. Écran thermique cpl.		
41	5000210194	3	pc	Sicherungsschraube Tornillo	Corrugated-head screw Vis		
42	5000206422	1	pc	Wartungsschalter Interruptor	Switch Interrupteur		
43	5000011548	2	pc	Zylinderschraube Tornillo cilíndrico	Cheese head screw Vis à tête cylindrique		
44	5000011552	2	pc	Zylinderschraube Tornillo cilíndrico	Cheese head screw Vis à tête cylindrique	M6 x 18 10Nm/7ft.lbs	ISO4762
45	5000210116	1	pc	O-Ring Anillo-o	O-ring Joint torique		

Halter Kpl.
Holder cpl.
Soporte cpl.
Attache cpl.

DPU80rLem670

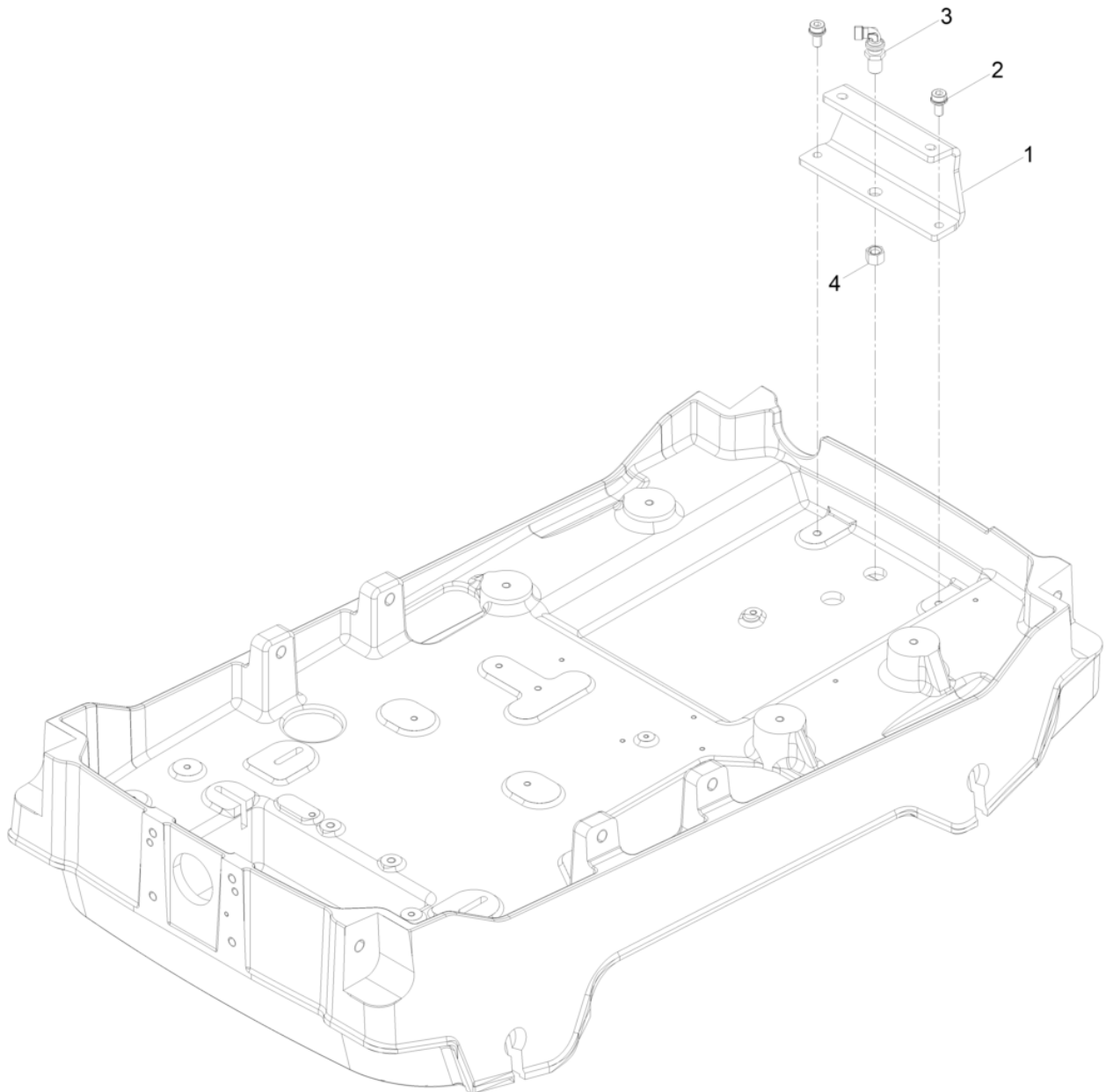

Pos. Item	Artikel Nr. Item no.	Pc.	Unit	Beschreibung Descripción	Description Description	Abm. Dim.	Norm Standard
						Drehmoment Torque	Schmierstoff Lubricant
1	5100010590	1	pc	Halter Soporte	Bracket Support		
2	5000210111	2	pc	Sicherungsschraube Tornillo	Corrugated-head screw Vis	90Nm/66ft.lbs	
3	5000205238	1	pc	Winkel-Schottverschraubung Atornilladura	Screw connection Raccord vis		
4	5000211773	1	pc	Verschlusskappe Tapa de cierre	Nose cap Chape de fermeture	40Nm/30ft.lbs	

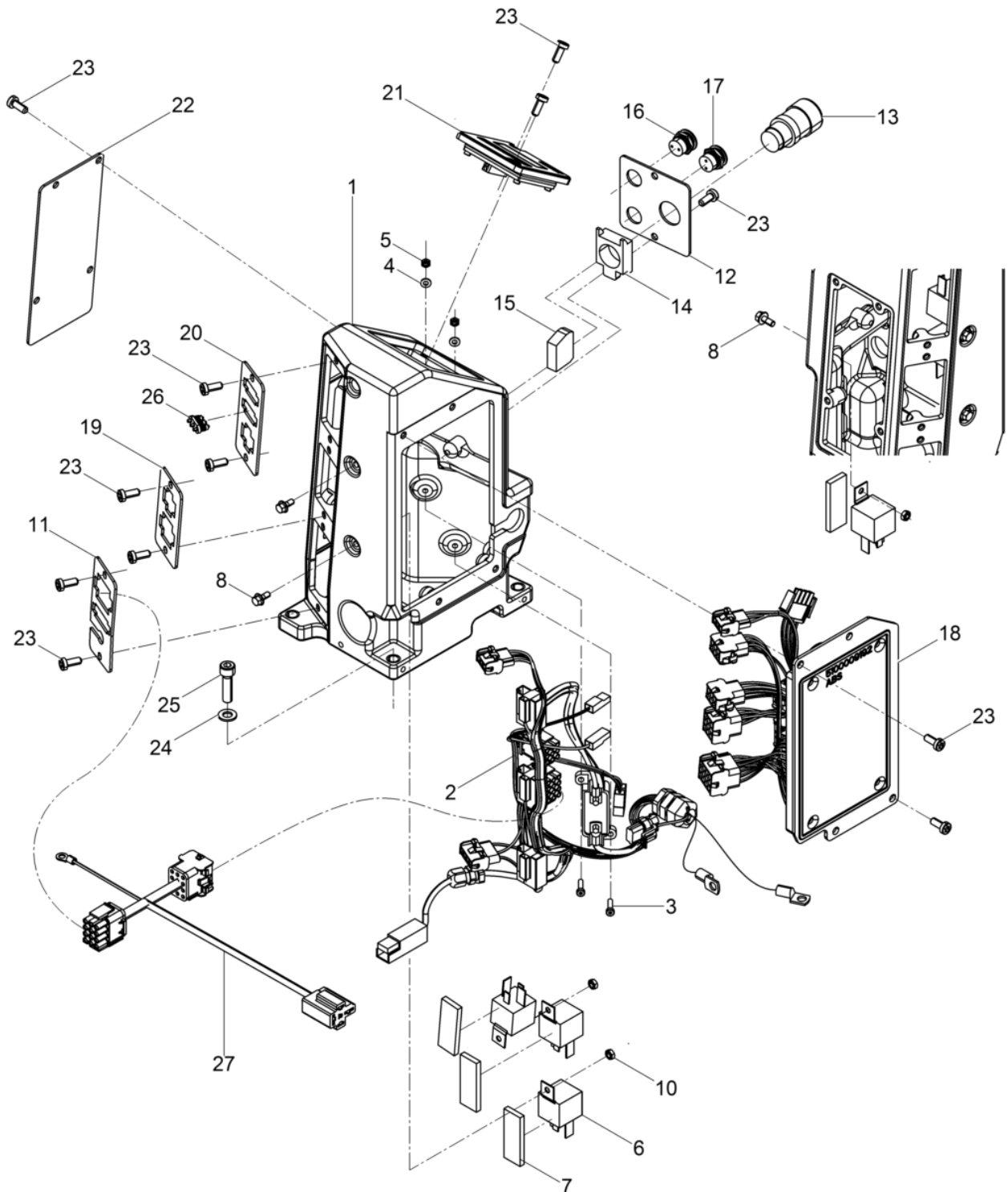

Pos. Item	Artikel Nr. Item no.	Pc.	Unit	Beschreibung Descripción	Description Description	Abm. Dim.	Norm Standard
						Drehmoment Torque	Schmierstoff Lubricant
1	5100005376	1	pc	Elektrobox Caja eléctrica	Electric components drawer Coffret électrique		
2	5100010129	1	pc	Kabelbaum E-Box Disp. del cable de elevacióncaja eléctrica	Cable harness e-box Faisceau de câbles		
3	5000011570	2	pc	Zylinderschraube Tornillo cilíndrico	Cheese head screw Vis à tête cylindrique	5Nm/4ft.lbs	
4	5000010628	2	pc	Scheibe Arandela	Flat washer Rondelle		
5	5000010370	2	pc	Sechskantmutter Tuerca hexagonal	Hexagon nut Écrou hexagonal		
6	5000085437	4	pc	Relais Relai	Relay Relais		
7	5100016686	4	pc	Dichtung Junta	Gasket Joint		
8	5100015757	3	pc	Sechskantschraube Tornillo hexagonal	Hexagonal head cap screw Vis à tête hexagonale	10Nm/7ft.lbs	
10	5000010369	3	pc	Sechskantmutter Tuerca hexagonal	Hexagon nut Écrou hexagonal		
11	5100010300	1	pc	Steckerblech Unten Chapa enchufe abajo	Connector plate bottom Tôle d'enchiffrage en bas		
12	5100010315	1	pc	Not-Aus Blech Chapa	Plate Tôle		
13	5100010121	1	pc	Betätigung Regulador	Control Commande		
14	5100010109	1	pc	Befestigungsflansch Brida	Flange Bride		
15	5100010110	1	pc	Hilfsschalter Interruptor	Switch Interrupteur		
16	5100005715	1	pc	Drucktaster Interruptor a pulsador	Botton switch Interrupteur de pression		
17	5100010070	1	pc	Drucktaster Interruptor a pulsador	Botton switch Interrupteur de pression		
18	5100005763	1	pc	Decoder Kpl. Decodificador cpl.	Decoder cpl. Décodeur cpl.		
19	5100010311	1	pc	Steckerblech Mitte Chapa enchufe centro	Connector plate middle Tôle d'enchiffrage centre		
20	5100010312	1	pc	Steckerblech Oben Chapa de enchufe superior	Connector plate top Tôle d'enchiffrage haut		
21	5100009818	1	pc	Anzeigeinheit Cuadro indicador	Display Afficheur, écran		
22	5100005471	1	pc	Deckel Tapa	Cover Couvercle		
23	5000108371	18	pc	Linsenkopfschraube Tornillo gota de sebo	Oval head screw Vis noyée lentiforme		
24	5000010622	3	pc	Scheibe Arandela	Flat washer Rondelle		
25	5000011541	3	pc	Zylinderschraube Tornillo cilíndrico	Cheese head screw Vis à tête cylindrique	25Nm/18ft.lbs	
26	5100022411	1	pc	Blindstecker Kpl. Enchufe cpl.	Blind plug cpl. Fiche borgne cpl.		
27	5100061282	1	pc	Kabelbaum Disp. del cable de elevación	Cable harness Faisceau de câbles		

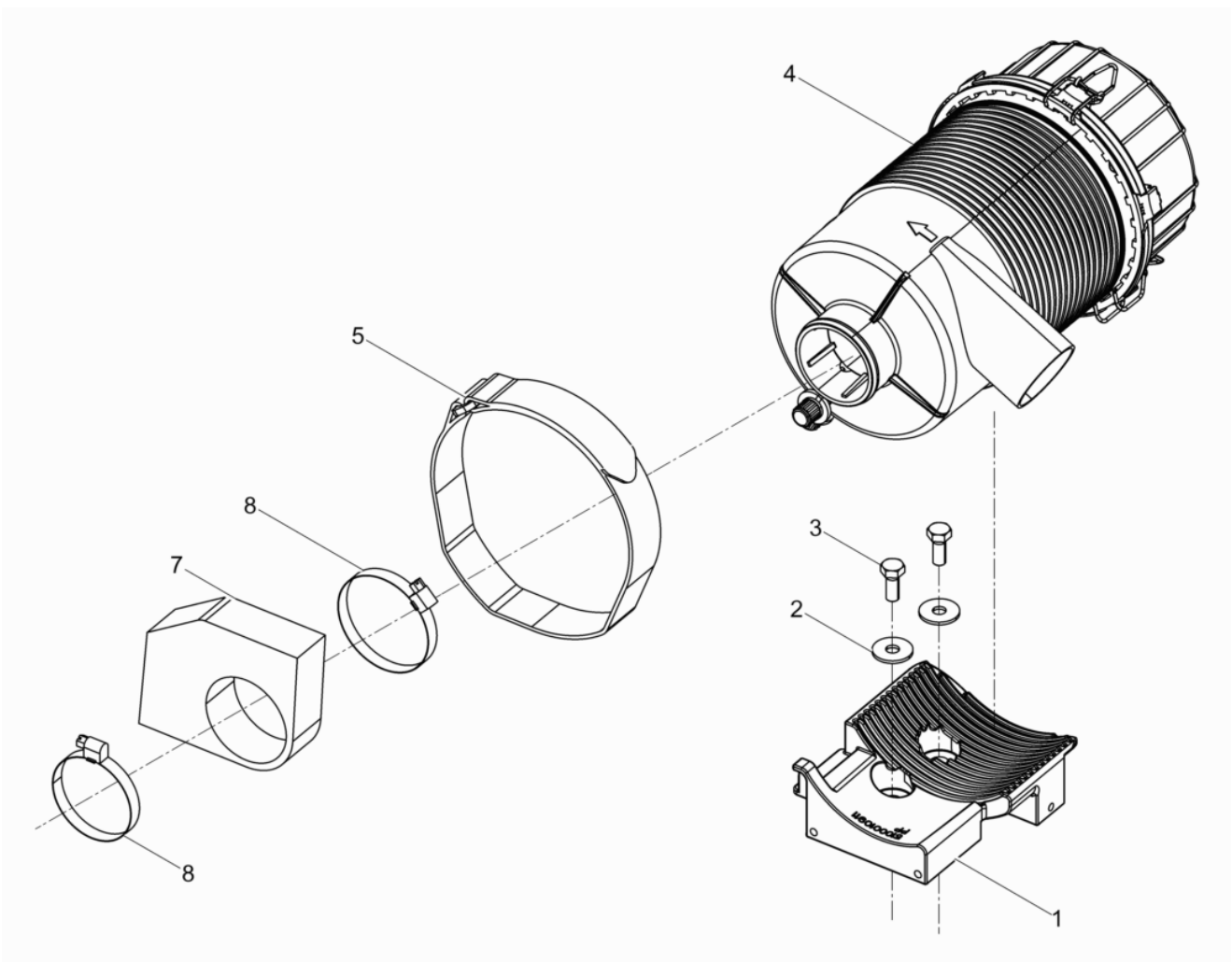

Pos. Item	Artikel Nr. Item no.	Pc.	Unit	Beschreibung Descripción	Description Description	Abm. Dim.	Norm Standard
						Drehmoment Torque	Schmierstoff Lubricant
1	5100010911	1	pc	Halter Soporte	Bracket Support		
2	5000010374	2	pc	Scheibe Arandela	Flat washer Rondelle		
3	5000012362	2	pc	Sechskantschraube Tornillo hexagonal	Hexagonal head cap screw Vis à tête hexagonale	25Nm/18ft.lbs	
4	5100005726	1	pc	Luftfilter Filtro del aire	Air cleaner Filtre à air		
4	5100024488	1	pc	Filterelement Elemento del filtro	Filter element Élément du filtre		
4	5100024489	1	pc	Sicherheitselement Elemento de seguridad	Safety elements Élément de sécurité		
4	5100024550	3	pc	Klemme Abrazadera	Clamp Pince		
4	5100024551	1	pc	Staubaustrittsventil Válvula	Dust discharge valve Soupape		
5	5100010912	1	pc	Spannband Collar	Tightening strap Bande de serrage		
7	5100016655	1	pc	Dichtung Junta	Gasket Joint		
8	5000014996	2	pc	Schneckengewindeschelle Abrazadera	Clamp Agrafe		

Verriegelung Hinten Kpl.
Locking device rear cpl.
Dispositivo de bloqueo atrás cpl.
Dispositif de verrouillage

DPU80rLem670

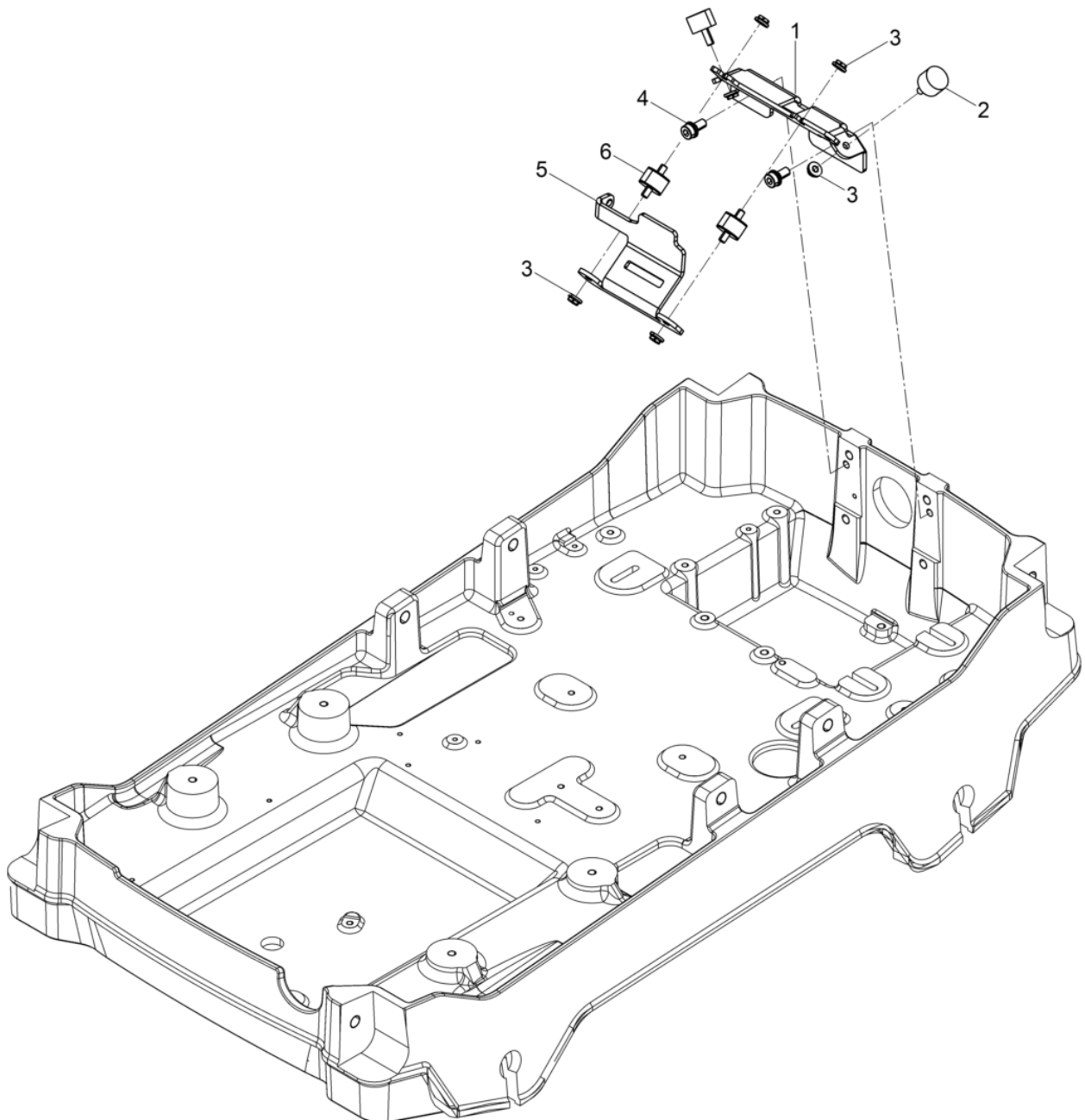

Pos. Item	Artikel Nr. Item no.	Pc.	Unit	Beschreibung Descripción	Description Description	Abm. Dim.	Norm Standard
						Drehmoment Torque	Schmierstoff Lubricant
1	5100010584	1	pc	Halter Soporte	Bracket Support		
2	5000204116	2	pc	Anschlagpuffer Amortiguador	Shockmount Silentbloc		
3	5100017158	6	pc	Sicherungsmutter Contratuercá	Locknut Contre-écrou	30Nm/22ft.lbs	
4	5000210111	2	pc	Sicherungsschraube Tornillo	Corrugated-head screw Vis	90Nm/66ft.lbs	
5	5100010580	1	pc	Verriegelungshebel Hinten Palanca de bloqueo atrás	Locking lever rear Levier de verrouillage arrière		
6	5100010840	2	pc	Gummi-Metall-Puffer Tope caucho-metal	Shockmount Tampon metallique oscillant		

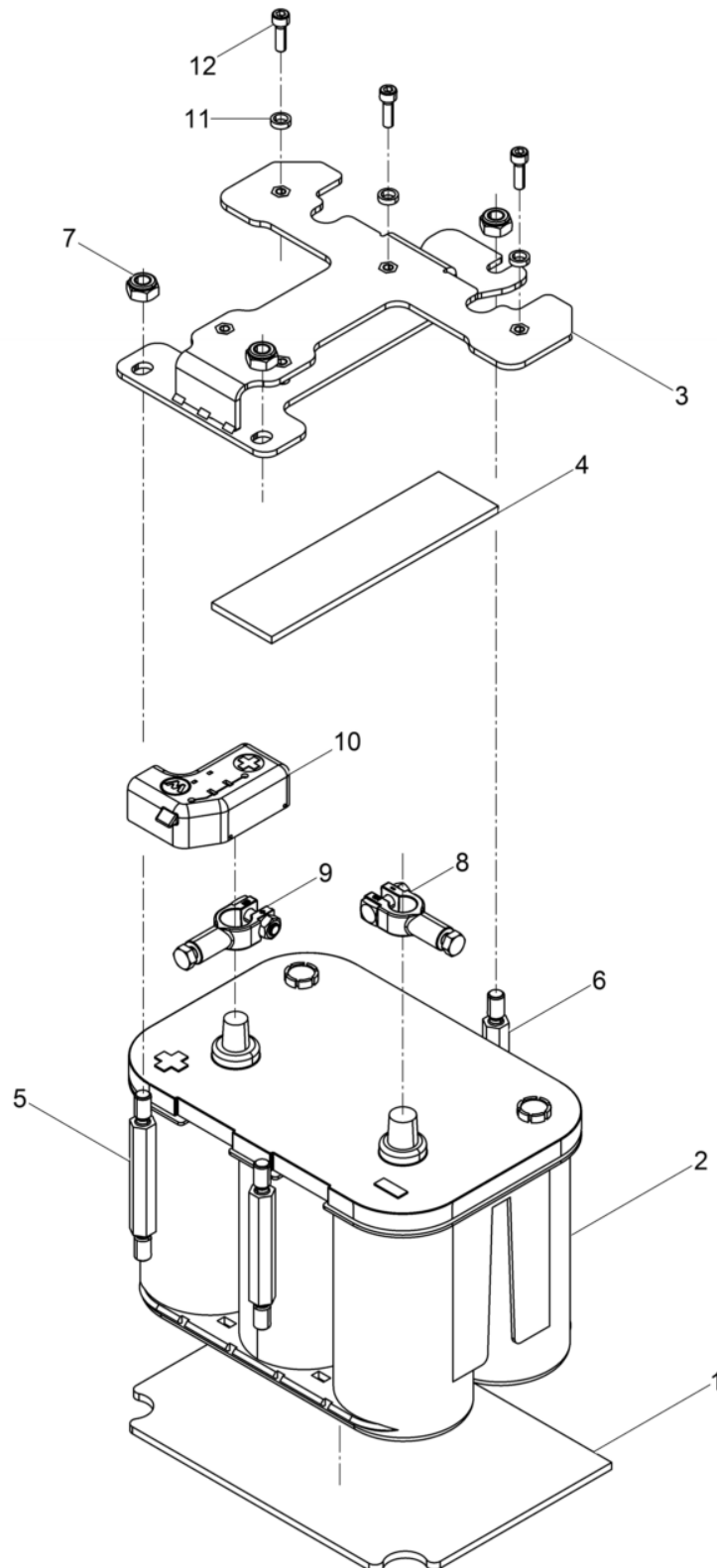

Pos. Item	Artikel Nr. Item no.	Pc.	Unit	Beschreibung Descripción	Description Description	Abm. Dim.	Norm Standard
						Drehmoment Torque	Schmierstoff Lubricant
1	5000209152	1	pc	Kissen Almohadilla	Insulating cushion Coussin		
2	5000086527	1	pc	Batterie Bateria	Battery Batterie		
3	5100005937	1	pc	Batteriehalterung Kpl. Montaje de batería cpl.	Battery mounting cpl. Fixation de batterie cpl.		
4	5100017160	1	pc	Dichtung Junta	Gasket Joint		
5	5100010891	1	pc	Gewindebolzen Perno roscado	Threaded bolt Boulon fileté	25Nm/18ft.lbs	
6	5100010892	2	pc	Gewindebolzen Perno roscado	Threaded bolt Boulon fileté	25Nm/18ft.lbs	
7	5000017313	3	pc	Sechskantmutter Tuerca hexagonal	Hexagon nut Écrou hexagonal	25Nm/18ft.lbs	
8	5100015203	1	pc	Polklemme Minuspol Terminal de polo negativo	Pole terminal negative Borne polaire negative		
9	5100015202	1	pc	Polklemme Pluspol Terminal de polo positivo	Pole terminal positive Borne polaire positive		
10	5100014022	1	pc	Pluspolabdeckung Tapa polo positivo	Positive pol cover Couverture		
11	5000212623	3	pc	Buchse Buje	Bushing Douille		
12	5000011551	3	pc	Zylinderschraube Tornillo cilíndrico	Cheese head screw Vis à tête cylindrique	10Nm/7ft.lbs	

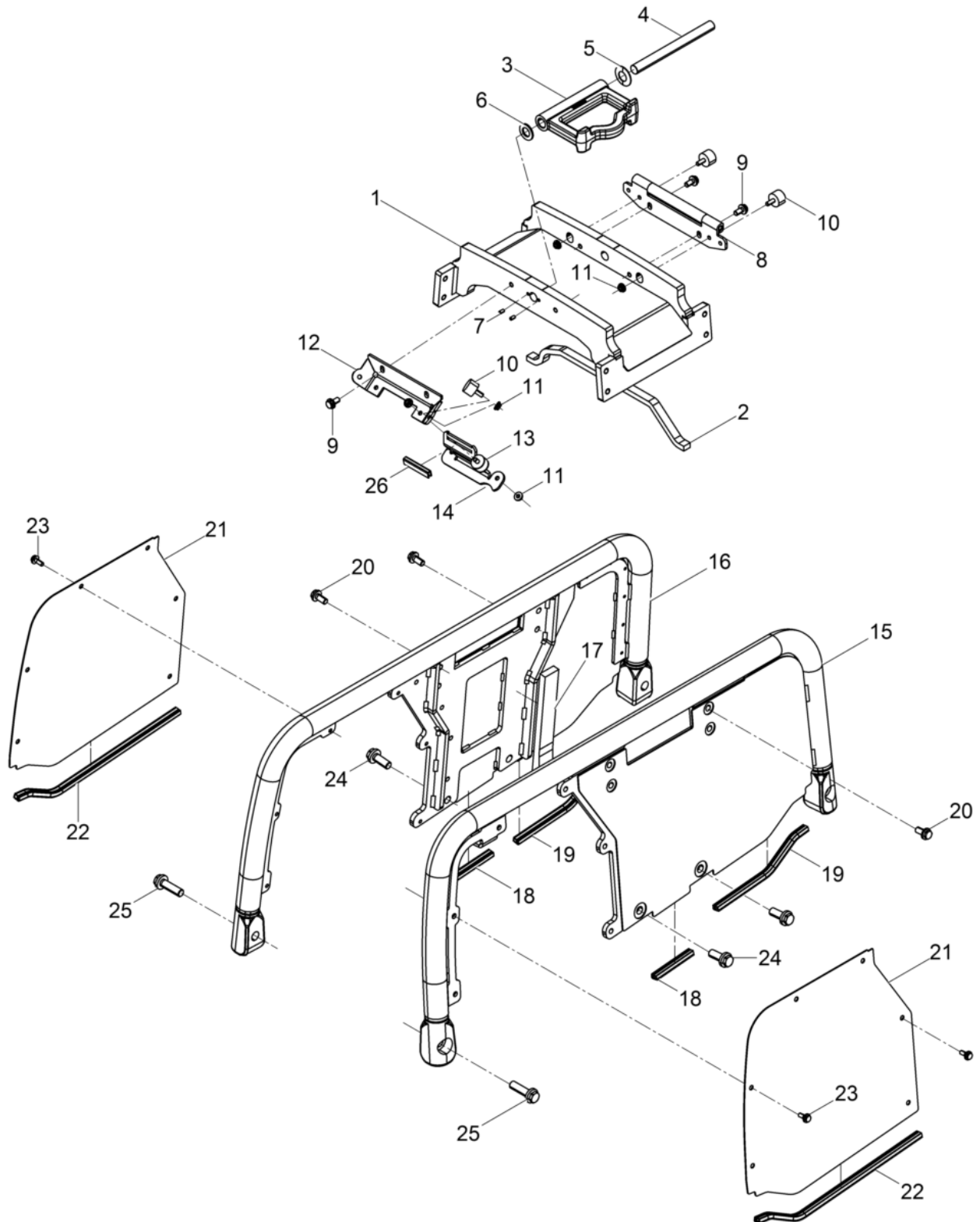

Pos. Item	Artikel Nr. Item no.	Pc.	Unit	Beschreibung Descripción	Description Description	Abm. Dim.	Norm Standard
						Drehmoment Torque	Schmierstoff Lubricant
1	5100010657	1	pc	Traverse Viga transversal	Cross-beam Entretoise		
2	5100016518	1	pc	Dichtung Junta	Gasket Joint		
3	5100017413	1	pc	Kranöse Ojete para grua	Jack ring Oeillet		
4	5100005732	1	pc	Achse Eje	Axle Axe		
5	5000202829	1	pc	Tellerfeder Resorte de platillo	Cup spring Ressort belleville		
6	5000010616	1	pc	Scheibe Arandela	Flat washer Rondelle		
7	5000126187	2	pc	Gewindestift Varilla roscada	Threaded pin Goupille fileté		
8	5100016051	1	pc	Scharnier Bisagra	Hinge Charnière		
9	5000210112	4	pc	Sicherungsschraube Tornillo	Corrugated-head screw Vis		
10	5000204116	4	pc	Anschlagpuffer Amortiguador	Shockmount Silentbloc		
11	5100017158	8	pc	Sicherungsmutter Contratuercas	Locknut Contre-écrou		
12	5100010583	1	pc	Halter Soporte	Bracket Support		
13	5100010840	2	pc	Gummi-Metall-Puffer Tope caucho-metal	Shockmount Tampon metallique oscillant		
14	5100064251	1	pc	Verriegelungshebel Palanca de bloqueo	Locking lever Lever de verrouillage		
15	5100010450	1	pc	Seitenteil Pieza lateral	Side element Partie laterale		
16	5100010451	1	pc	Seitenteil Pieza lateral	Side element Partie laterale		
17	5100016517	2	pc	Dichtung Junta	Gasket Joint		
18	5100018100	2	pc	Kantenschutz Protección de cantos	Edge protection Protege arete		
19	5100018101	2	pc	Kantenschutz Protección de cantos	Edge protection Protege arete		
20	5100018059	8	pc	Sicherungsschraube Tornillo de seguridad	Corrugated-head screw Vis de sécurité		
21	5100010459	2	pc	Abdeckung Cubierta	Covering Couverture		
22	5100018102	2	pc	Kantenschutz Protección de cantos	Edge protection Protege arete		
23	5000211795	12	pc	Sicherungsschraube Tornillo	Corrugated-head screw Vis		
24	5100011100	4	pc	Sicherungsschraube Tornillo de seguridad	Corrugated-head screw Vis de sécurité		
25	5100011101	4	pc	Sicherungsschraube Tornillo de seguridad	Corrugated-head screw Vis de sécurité		
26	5100025691	1	pc	Griffprofil Perfil mango	Handle profile Profil de la poignée		

Haube Vorne Kpl. DPU80
Bonnet front cpl. dpu80
Cubierta delantero cpl. dpu80
Capot avant cpl. dpu80

DPU80rLem670

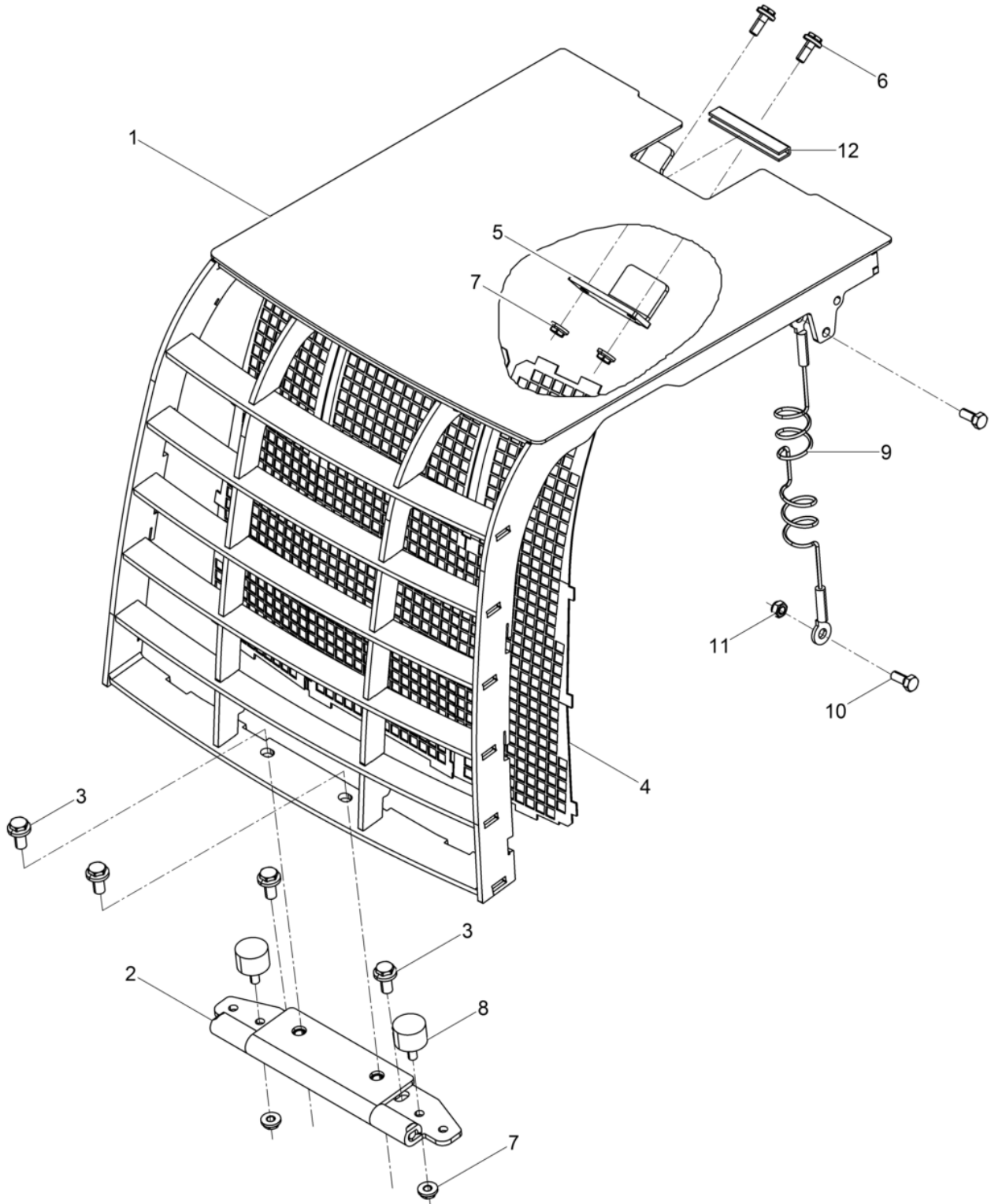

Pos. Item	Artikel Nr. Item no.	Pc.	Unit	Beschreibung Descripción	Description Description	Abm. Dim.	Norm Standard
						Drehmoment Torque	Schmierstoff Lubricant
1	5100010439	1	pc	Haube Cubierta	Bonnet Capot		
2	5100016051	1	pc	Scharnier Bisagra	Hinge Charnière		
3	5000210112	4	pc	Sicherungsschraube Tornillo	Corrugated-head screw Vis	85Nm/63ft.lbs	
4	5100010931	1	pc	Schutzgitter Vorne (DPU80) Rejilla de protección delantero (dpu80)	Screen grid rear (dpu80) Grille de protection avant		
4	5100018930	1	pc	Schutzgitter Vorne (Dpu80r) Rejilla de protección delantero (dpu80r)	Screen grid front (dpu80r) Grille de protection avant		
5	5100010577	1	pc	Verriegelungslasche Vorne Lengüeta de bloqueo delantero	Locking tab front Languette de verrouillage		
6	5100018058	2	pc	Sicherungsschraube Tornillo de seguridad	Corrugated-head screw Vis de sécurité		
7	5100017158	4	pc	Sicherungsmutter Contratuercia	Locknut Contre-écrou	30Nm/22ft.lbs	
8	5100024474	2	pc	Anschlagpuffer Amortiguador	Shockmount Silentbloc		
9	5000154402	1	pc	Kabel Cable	Cable Câble		
10	5000012362	2	pc	Sechskantschraube Tornillo hexagonal	Hexagonal head cap screw Vis à tête hexagonale	25Nm/18ft.lbs	
11	5000033356	2	pc	Sechskantmutter Tuerca hexagonal	Hexagon nut Écrou hexagonal		
12	5100024476	1	pc	Kantenschutz Protección de cantos	Edge protection Protege arete	90Nm/66ft.lbs	

Haube Hinten Kpl. DPU80
Bonnet rear cpl. dpu80
Cubierta atrás cpl. dpu80
Capot arrière cpl. dpu80

DPU80rLem670

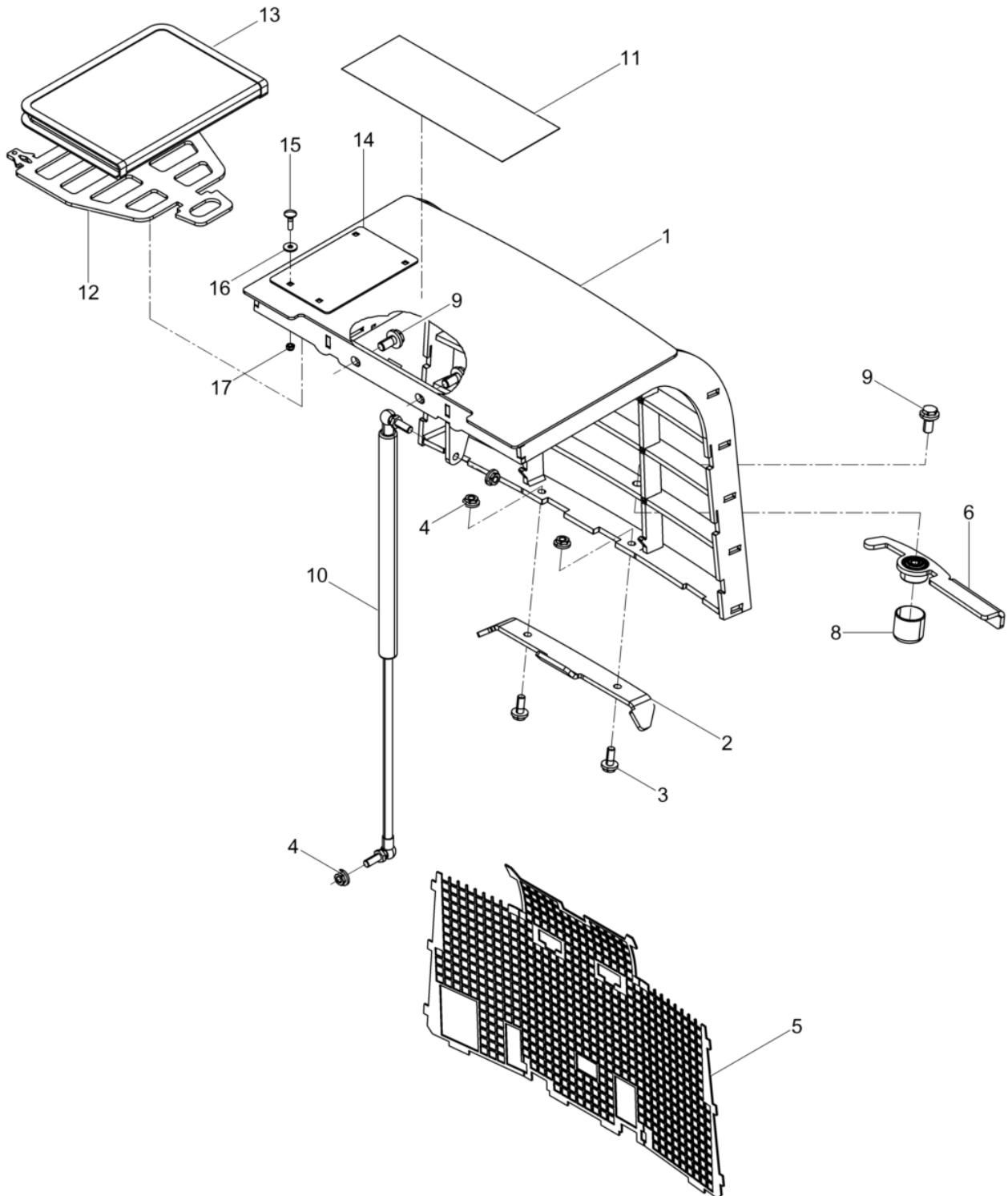

Pos. Item	Artikel Nr. Item no.	Pc.	Unit	Beschreibung Descripción	Description Description	Abm. Dim.	Norm Standard
						Drehmoment Torque	Schmierstoff Lubricant
1	5100010438	1	pc	Haube Cubierta	Bonnet Capot		
2	5100010578	1	pc	Verriegelungslasche Hinten Lengüeta de bloqueo atrás	Locking tab rear Languette de verrouillage		
3	5100018058	2	pc	Sicherungsschraube Tornillo de seguridad	Corrugated-head screw Vis de sécurité		
4	5100017158	4	pc	Sicherungsmutter Contratuerca	Locknut Contre-écrou	30Nm/22ft.lbs	
5	5100010933	1	pc	Schutzgitter Hinten (DPU80) Rejilla de protección atrás (dpu80)	Screen grid rear (dpu80) Grille de protection arrière		
5	5100018919	1	pc	Schutzgitter Vorne (DPU80) Rejilla de protección delantero (dpu80)	Screen grid front (dpu80) Grille de protection avant		
5	5100018920	1	pc	Schutzgitter Vorne (Dpu80r,C) Rejilla de protección delantero (dpu80r,c)	Screen grid front (dpu80r,c) Grille de protection avant		
5	5100018924	1	pc	Schutzgitter Vorne (Dpu80r) Rejilla de protección delantero (dpu80r)	Screen grid front (dpu80r) Grille de protection avant		
6	5100011262	1	pc	Hebel Kpl. Palanca cpl.	Lever cpl. Levier cpl.		
8	5000068355	1	pc	Schutzkappe Capa de protección	Protective cap Chape de protection		
9	5000210112	3	pc	Sicherungsschraube Tornillo	Corrugated-head screw Vis	85Nm/63ft.lbs	
10	5100005810	1	pc	Gasdruckfeder Resorte de compresión	Compr. spring Ressorte de pression		
11	5100017956	1	pc	Schutzfolie Hoja de protección	Protection foil Cliquant protection		
12	5100024201	1	pc	Lappen Trapo	Cloth Languette		
13	5100025231	1	pc	Mappe Carpeta	Portfolio Portefeuille		
14	5100057038	1	pc	Blech Chapa	Plate Tôle		
15	5100048321	4	pc	Schloßschraube Tornillo	Mushroom head bolt Vis		
16	5000010372	4	pc	Scheibe Arandela	Flat washer Rondelle	B5,3	DIN9021
17	5000010369	4	pc	Sechskantmutter Tuerca hexagonal	Hexagon nut Écrou hexagonal		

Sender Kpl.
Transmitter cpl.
Transmisor cpl.
Transmetteur cpl.

DPU80rLem670

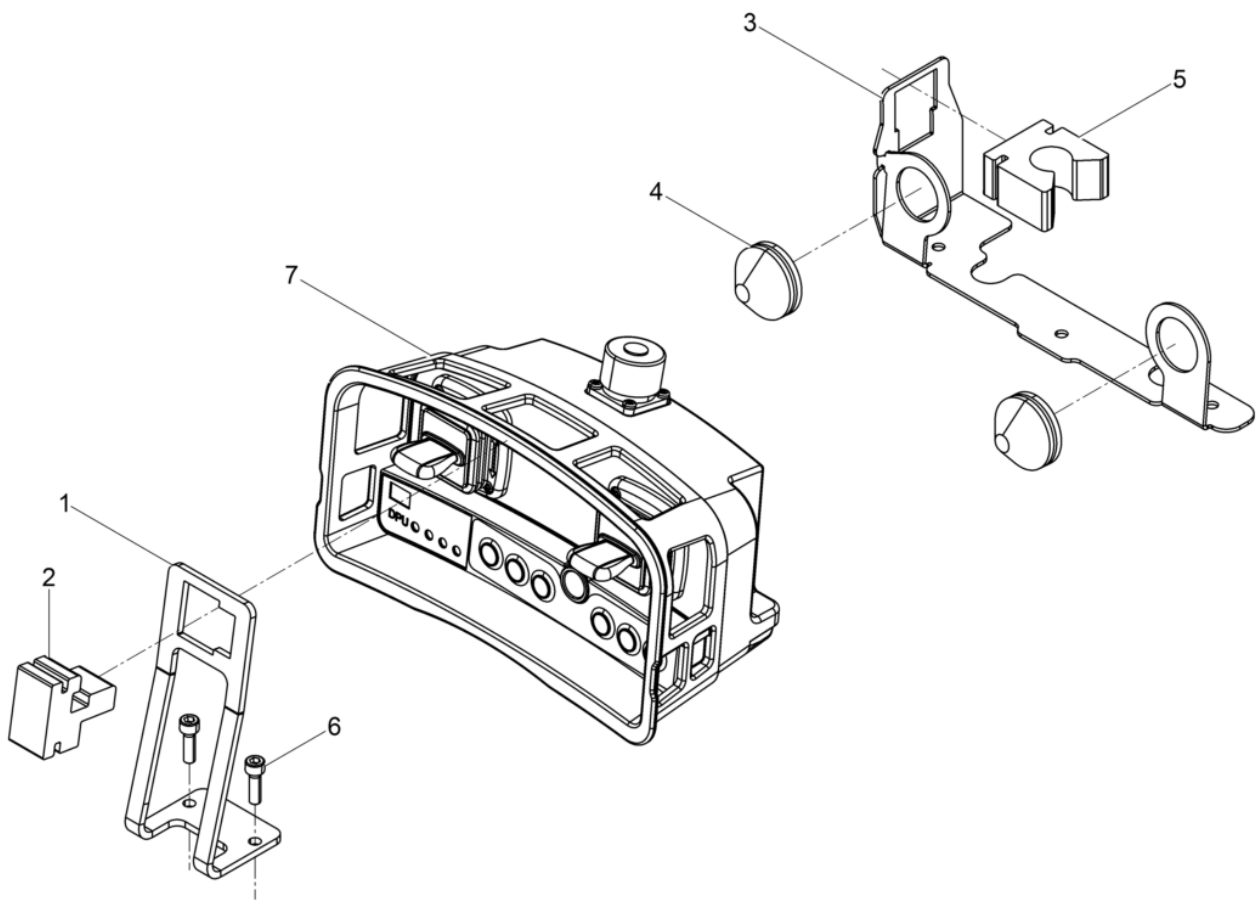

Pos. Item	Artikel Nr. Item no.	Pc.	Unit	Beschreibung Descripción	Description Description	Abm. Dim.	Norm Standard
						Drehmoment Torque	Schmierstoff Lubricant
1	5100005938	1	pc	Gegenhalter Soporte	Retainer Logement		
2	5000207753	1	pc	Halterung Soporte	Bracket Équerre		
3	5100005940	1	pc	Klemmleiste Regleta de sujeción	Terminal strip Triangle de serrage		
4	5000124255	2	pc	Batteriepuffer Tope	Shockmount Tampon		
5	5000208255	1	pc	Halterung Soporte	Bracket Équerre		
6	5000011551	2	pc	Zylinderschraube Tornillo cilindrico	Cheese head screw Vis à tête cylindrique	95Nm/70ft.lbs	
7	5100018542	1	pc	Sender Transmisor	Transmitter Transmetteur		

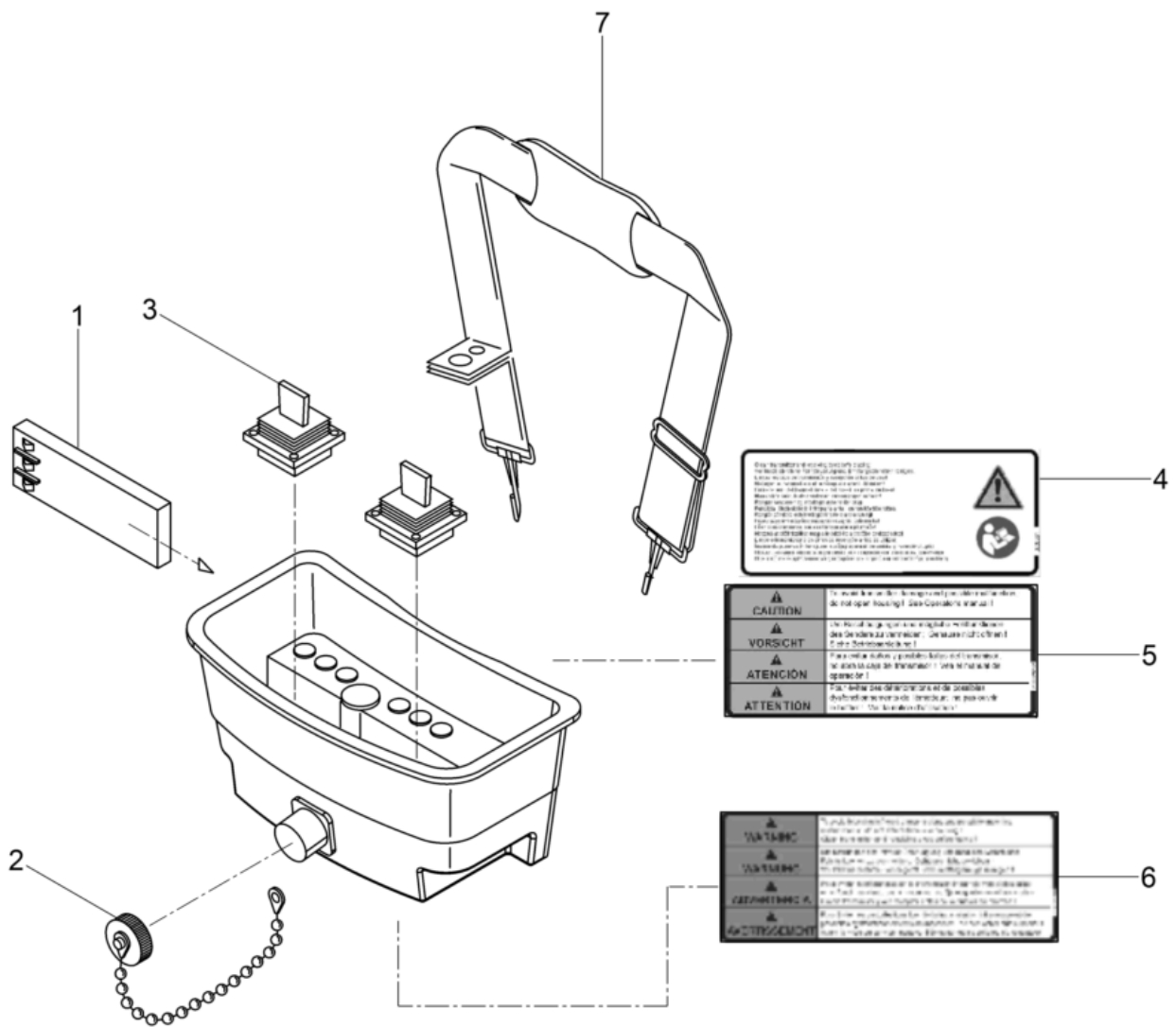

Pos. Item	Artikel Nr. Item no.	Pc.	Unit	Beschreibung Descripción	Description Description	Abm. Dim.	Norm Standard
						Drehmoment Torque	Schmierstoff Lubricant
1	5000210156	1	pc	Akku Batería	Battery Accumalteur		
2	5000117184	1	pc	Kappe Tapa	Cap Couvercle		
3	5000177083	2	pc	Steuerhebel-Satz Palanca de dirección-juego	Steering lever kit Lever de direction-jeu		
4	5000226261	1	pc	Aufkleber Calcomania	Label Autocollant		
5	5100024202	1	pc	Aufkleber-Hinweis Calcomanía-indicación	Instruction label Autocollant avec indication		
6	5100024203	1	pc	Aufkleber-Warnung Calcomania-advertencia	Label-warning Autocollant-avertissement		
7	5100024204	1	pc	Band Cinta	Band Ruban		

Maschinenschutz Kpl.
Overload sensor cpl.
Sobrecarga sensor cpl.
Surcharge capteur cpl.

DPU80rLem670

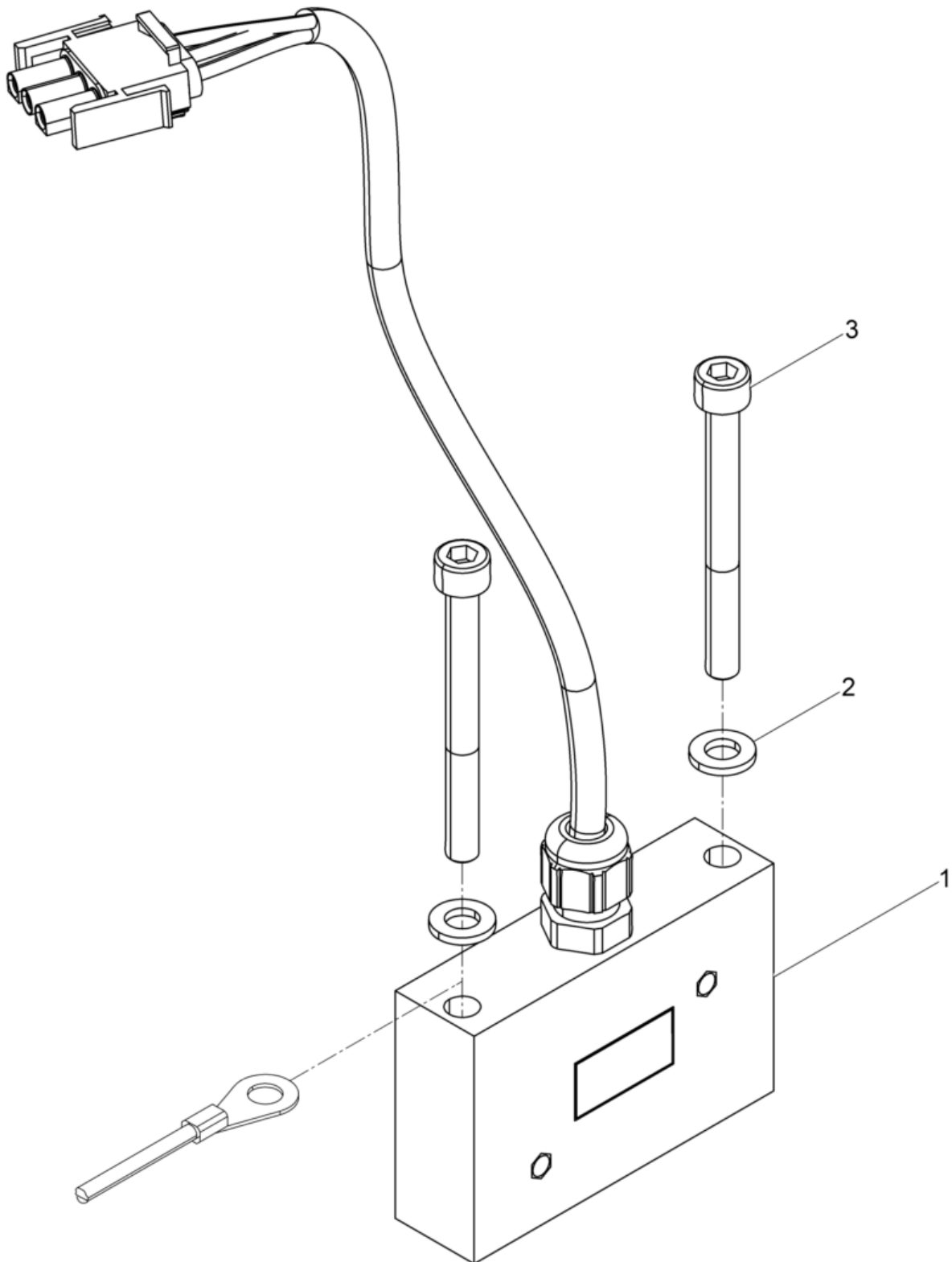

Pos. Item	Artikel Nr. Item no.	Pc.	Unit	Beschreibung Descripción	Description Description	Abm. Dim.	Norm Standard
						Drehmoment Torque	Schmierstoff Lubricant
1	5100010005	1	pc	Sensor Kpl. Sensor cpl.	Sensor cpl. Capteur cpl.		
2	5000010624	1	pc	Scheibe Arandela	Flat washer Rondelle		
3	5000037071	2	pc	Zylinderschraube Tornillo cilíndrico	Cheese head screw Vis à tête cylindrique	10Nm/7ft.lbs	

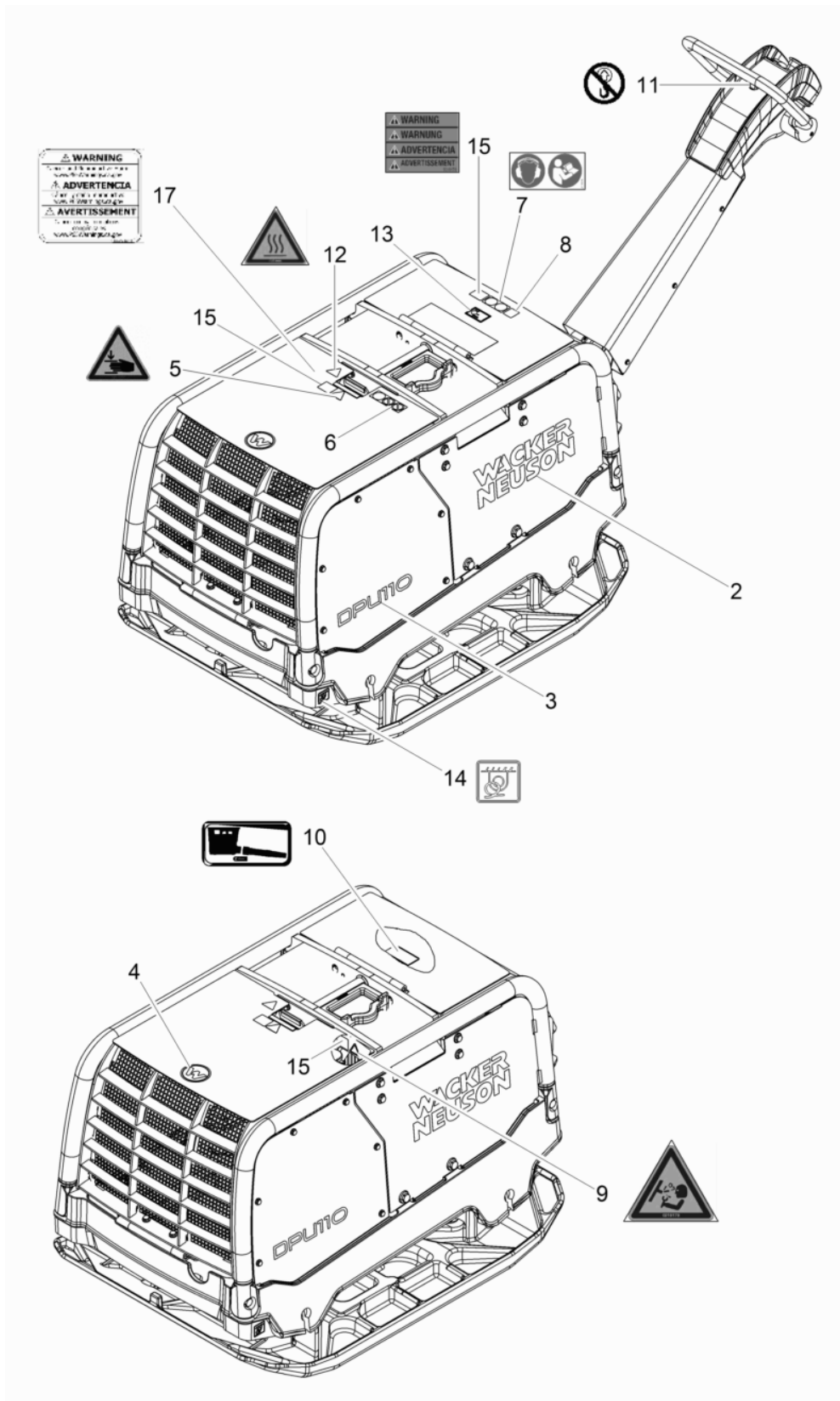

Pos. Item	Artikel Nr. Item no.	Pc.	Unit	Beschreibung Descripción	Description Description	Abm. Dim.	Norm Standard
						Drehmoment Torque	Schmierstoff Lubricant
2	5000222103	2	pc	Aufkleber Logo Calcomania insignia	Label logo Autocollant logo	80 mm	
3	5100017952	2	pc	Aufkleber-Typ DPU110 Tipo etiqueta autoadhesiva dpu110	Type label dpu110 Autocollant de type dpu110		
3	5100017953	2	pc	Aufkleber-Typ Dpu110r Tipo etiqueta autoadhesiva dpu110r	Type label dpu110r Autocollant de type dpu110r		
3	5100017954	2	pc	Aufkleber-Typ DPU80 Tipo etiqueta autoadhesiva 80	Type label dpu80 Autocollant de type dpu80		
3	5100017955	2	pc	Aufkleber-Typ Dpu80r Tipo etiqueta autoadhesiva 80r	Type label dpu80r Autocollant de type dpu80r		
3	5100024540	2	pc	Aufkleber Typ DPU90 Tipo etiqueta autoadhesiva dpu90	Type label dpu90 Aufkleber typ dpu90		
3	5100024541	2	pc	Aufkleber Typ Dpu90r Tipo etiqueta autoadhesiva dpu90r	Type label dpu90r Autocollant de type dpu90r		
4	5000222086	1	pc	Aufkleber Symbol Calcomania símbololo	Label symbol Autocollant symbole		
5	5000207747	1	pc	Aufkleber Quetschgefahr Calcomania de peligro	Danger label Autocollant de danger		
6	5000216633	1	pc	Aufkleber-Hinweis Calcomanía-indicación	Instruction label Autocollant avec indication		
7	5000219175	1	pc	Aufkleber Calcomanias	Labels Autocollants		
8	5000064925	1	pc	Aufkleber-Schalleistungspegel Etiqueta autoadhesiva-nivel de potencia acúëstica	Decal-sound power level Autocollante-niveau sonore		
9	5000219179	1	pc	Aufkleber Calcomanias	Labels Autocollants		
10	5000216635	1	pc	Aufkleber Calcomanias	Labels Autocollants		
11	5000220000	1	pc	Aufkleber-Warnhinweis Calcomanía-indicación	Instruction label Autocollant avec indication		
12	5000219080	1	pc	Aufkleber Calcomanias	Labels Autocollants		
13	5100011227	1	pc	Aufkleber HAV 24H Calcomania hav 24h	Label hav 24h Autocollant hav 24h		
14	1000184310	4	pc	Aufkleber Calcomania	Label Autocollant		
15	5000219176	3	pc	Aufkleber Calcomanias	Labels Autocollants		
17	5100045462	1	pc	Aufkleber Calcomania	Label Autocollant		

Pos. Item	Artikel Nr. Item no.	Pc.	Unit	Beschreibung Descripción	Description Description	Abm. Dim.	Norm Standard
						Drehmoment Torque	Schmierstoff Lubricant
1	5100026266	1	pc	Krabelwelle Cigueñal	Crankshaft Vilebrequin		
2	5000159357	1	pc	Stift Espiga	Pin Goupille		
3	5000159260	1	pc	Woodruffkeil Chaveta woodruff	Woodruff key Clavette woodruff		
4	5000159454	2	pc	Schraubverschluß Tapón roscado	Plug (threaded) Bouchon		
5	5000159261	1	pc	Passfeder Chaveta	Square key Clavette		

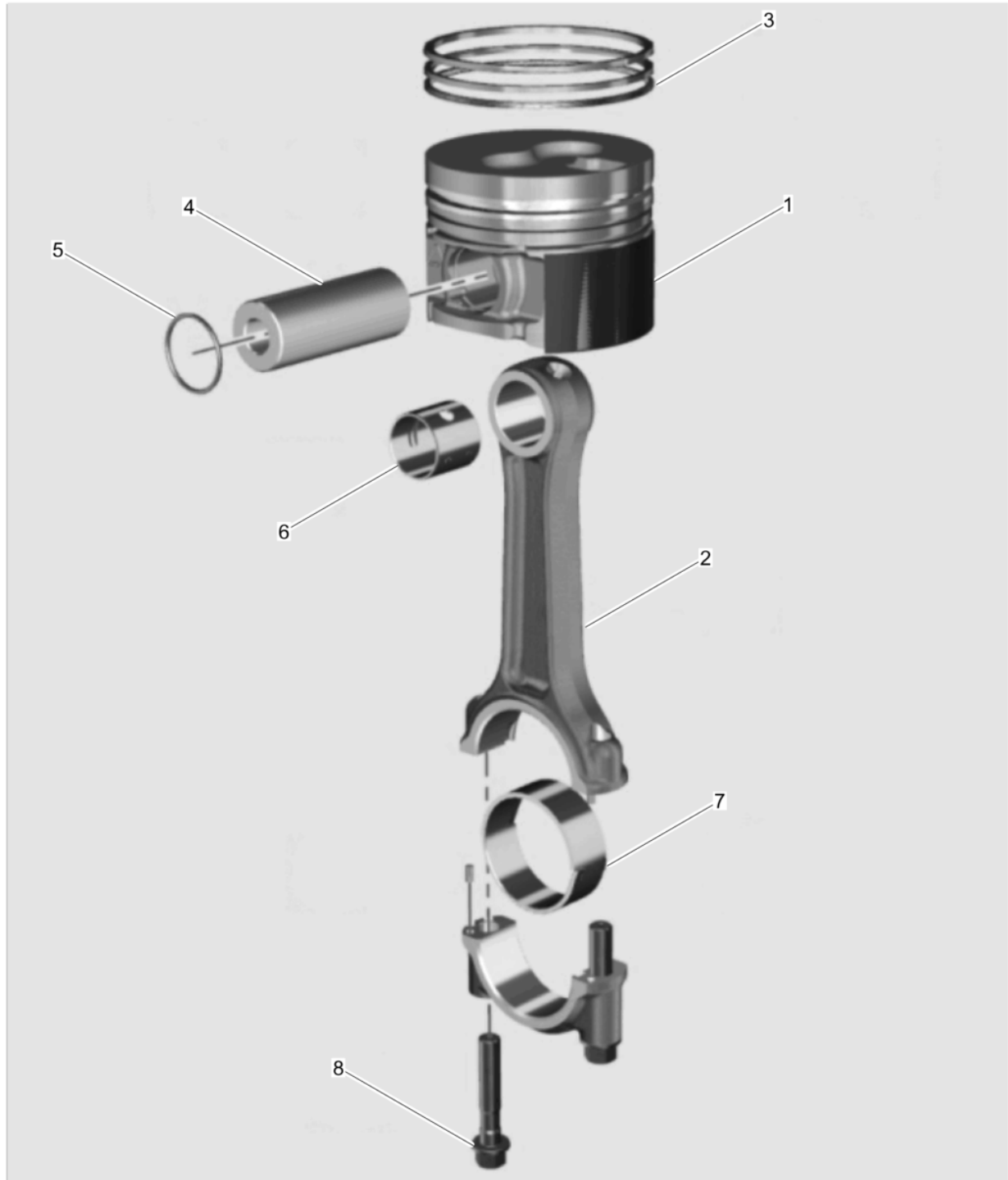

Pos. Item	Artikel Nr. Item no.	Pc.	Unit	Beschreibung Descripción	Description Description	Abm. Dim.	Norm Standard
						Drehmoment Torque	Schmierstoff Lubricant
1	5000160375	2	pc	Kolbensatz Juego de pistón	Set of piston Jeu de piston		
1	5000160376	2	pc	Kolbensatz Juego de pistón	Set of piston Jeu de piston		
1	5000160377	2	pc	Kolbensatz Juego de pistón	Set of piston Jeu de piston		
2	5000160367	2	pc	Pleuel Biela	Connecting rod Bielle		
3	5000160383	2	pc	Kolbenringsatz Juego de cubo levantador	Piston ring set Jeu de moyeu de levage		
3	5000160384	2	pc	Ringsatz Juego de cubo levantador	Piston ring set Jeu de moyeu de levage		
3	5000160385	2	pc	Ringsatz Juego de cubo levantador	Piston ring set Jeu de moyeu de levage		
4	5000215523	2	pc	Kolbenbolzen Perno de pistón	Piston pin Axe de piston		
5	5000215477	4	pc	Sicherungsring Anillo de retención	Retaining ring Bague d'arrêt		
6	5100053523	2	pc	Buchse Buje	Bushing Douille		
7	5000155689	2	pc	Lagerschalen Rodamiento	Bearing Roulement		
7	5000155690	2	pc	Pleuellagerangen Rodamiento	Bearing Roulement		
7	5000155691	2	pc	Pleuellagerangen Rodamiento	Bearing Roulement		
8	5000084175	4	pc	Schraube Tornillo	Screw Vis		

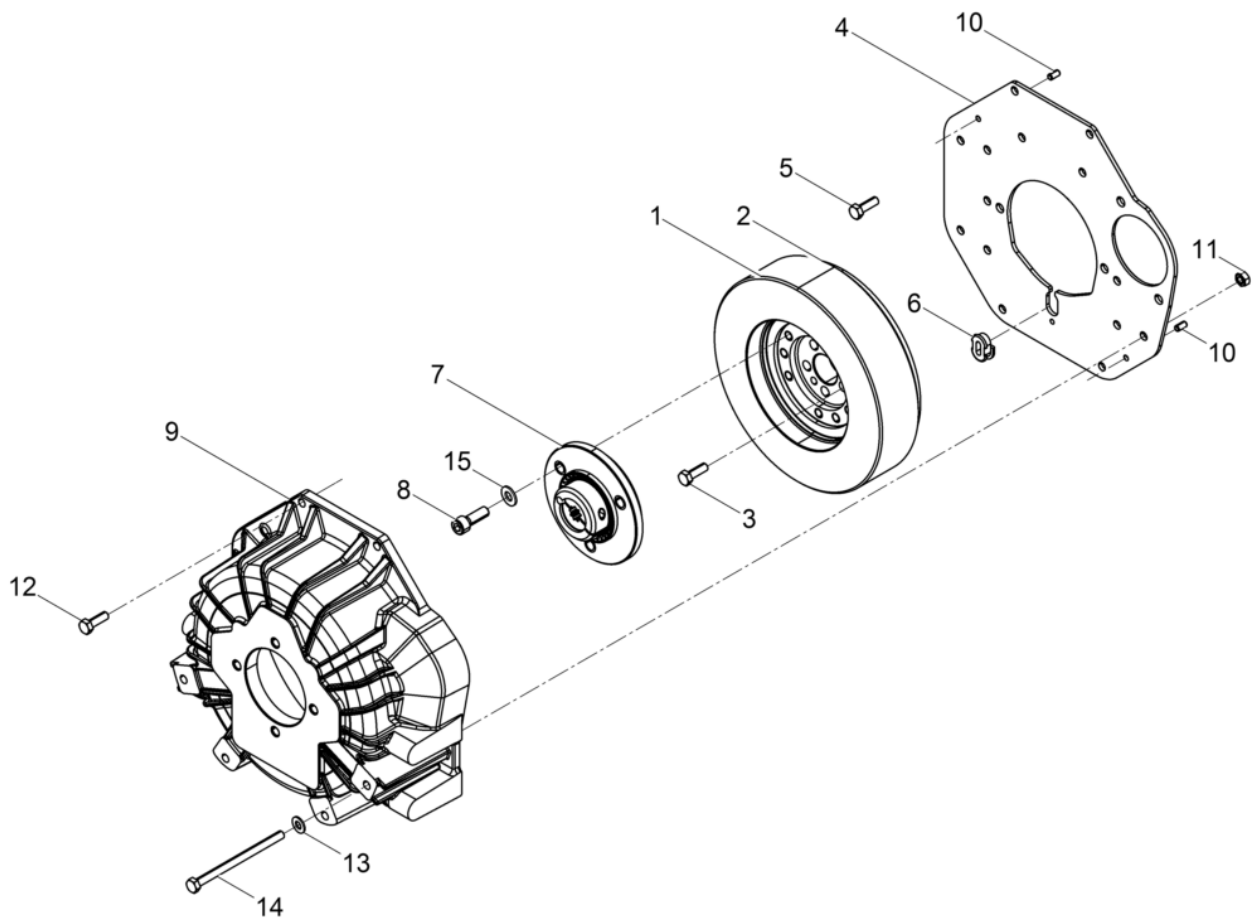

Pos. Item	Artikel Nr. Item no.	Pc.	Unit	Beschreibung Descripción	Description Description	Abm. Dim.	Norm Standard
						Drehmoment Torque	Schmierstoff Lubricant
1	5000215545	1	pc	Schwungrad Volante	Flywheel Volant		
2	5000155693	1	pc	Zahnkranz Borde de engranaje	Gear crown Jante d'engrenage		
3	5000160188	5	pc	Bolzen Perno	Bolt Boulon		
4	5000159326	1	pc	Platte Placa	Plate Plaque		
5	5000159254	9	pc	Bolzen Perno	Bolt Boulon		
6	5000215527	1	pc	Stopfen Tapón	Plug Bouchon		
7	5000211373	1	pc	Kupplung Kpl. Embrague cpl.	Coupling cpl. Embrayage cpl.		
8	5000084164	3	pc	Schraube Tornillo	Screw Vis		
9	5000215567	1	pc	Halter Soporte	Holder Attache		
10	5000211370	2	pc	Stift Espiga	Pin Goupille		
11	5000082140	3	pc	Mutter Tuerca	Nut Écrou		
12	5000084123	3	pc	Schraube Tornillo	Screw Vis		
13	5000211371	4	pc	Scheibe Disco	Washer Rondelle		
14	5000211372	4	pc	Schraube Tornillo	Screw Vis		
15	5000160231	3	pc	Scheibe Disco	Washer Rondelle		

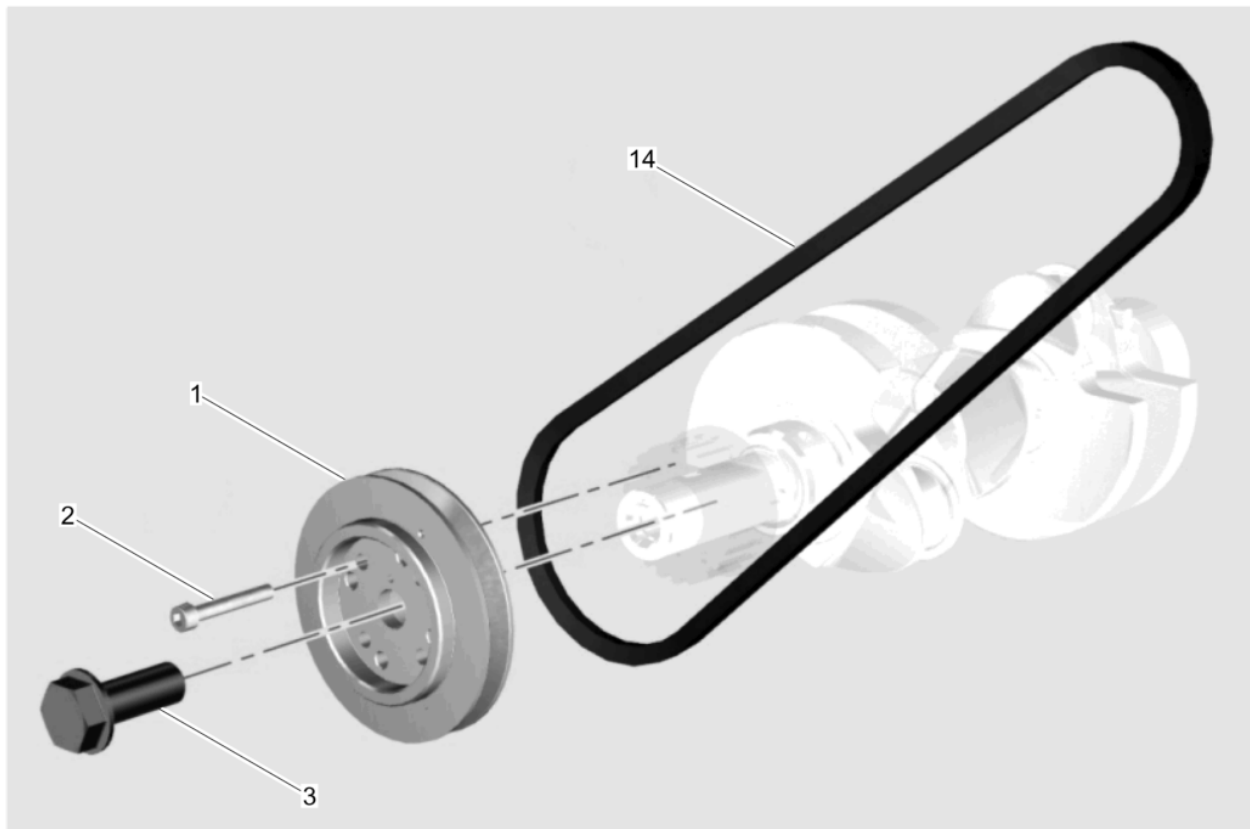

Pos. Item	Artikel Nr. Item no.	Pc.	Unit	Beschreibung Descripción	Description Description	Abm. Dim.	Norm Standard
						Drehmoment Torque	Schmierstoff Lubricant
1	5100026267	1	pc	Riemenscheibe Polea	V-belt pulley Poulie		
2	5000159475	4	pc	Schraube Tornillo	Screw Vis		
3	5000126935	1	pc	Bolzen Perno	Bolt Boulon		
14	5100049822	1	pc	Keilriemen Correa en v	V-belt Courroie		

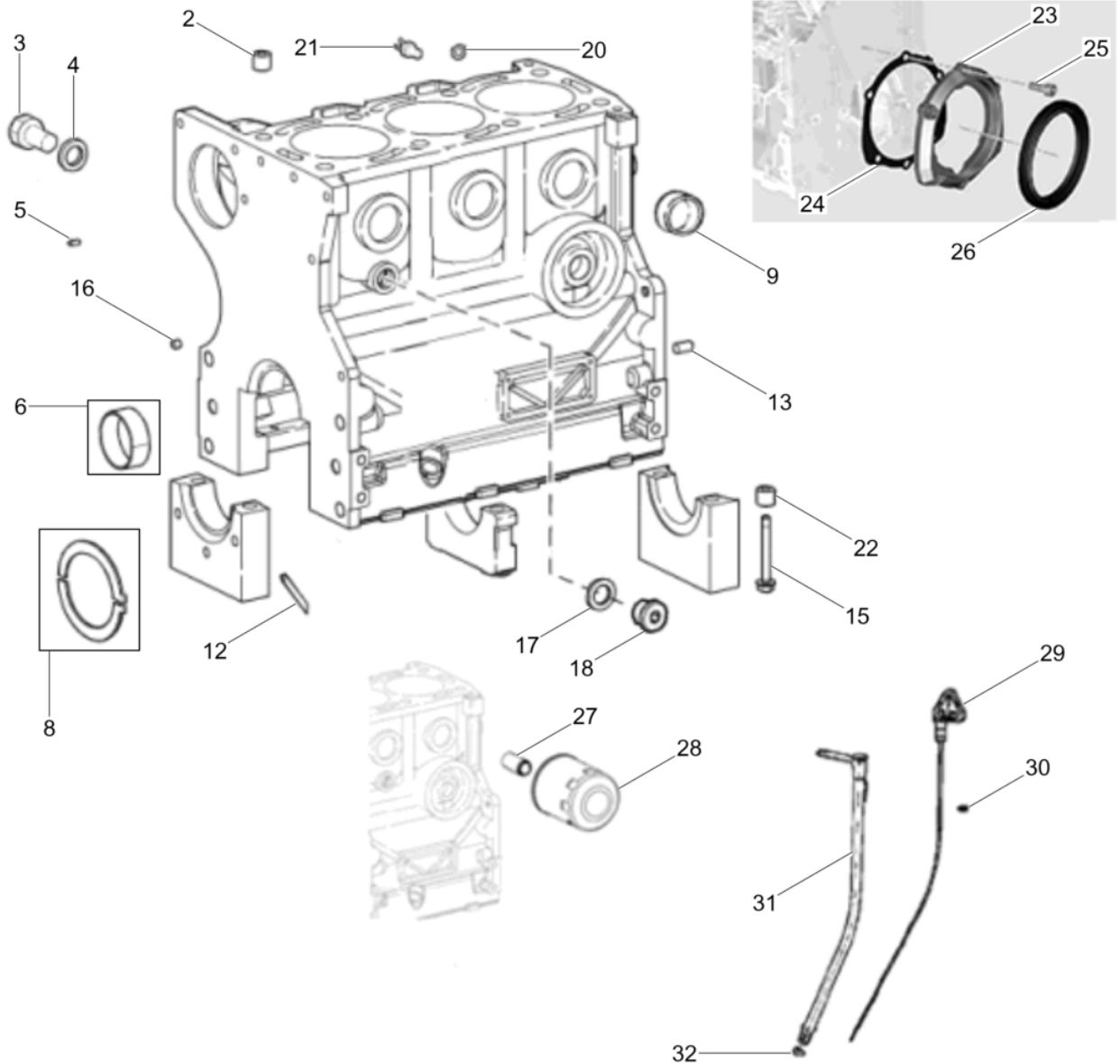

Pos. Item	Artikel Nr. Item no.	Pc.	Unit	Beschreibung Descripción	Description Description	Abm. Dim.	Norm Standard
						Drehmoment Torque	Schmierstoff Lubricant
2	5000159257	2	pc	Hülse Collar	Sleeve Douille		
3	5000206229	1	pc	Schraube Tornillo	Screw Vis		
4	5000082184	1	pc	Dichtring Anillo sellador	Ring seal Rondelle à étancher		
5	5000215522	1	pc	Stift Espiga	Pin Goupille		
6	5000155702	3	pc	Lager Cojinete	Bearing Palier		
6	5000155703	3	pc	Lager Cojinete	Bearing Palier		
6	5000155704	3	pc	Lager Cojinete	Bearing Palier		
8	5000159486	2	pc	Scheibe Disco	Disc Disque		
8	5000159487	2	pc	Scheibe Disco	Disc Disque		
8	5000159488	2	pc	Scheibe Disco	Disc Disque		
9	5000082335	2	pc	Schraubverschluß Tapón roscado	Plug (threaded) Bouchon		
12	5000159288	4	pc	Dichtung Junta	Gasket Joint		
13	5000159360	2	pc	Paßstift Espiga	Dowel pin Cheville		
15	5000159480	6	pc	Schraube Tornillo	Screw Vis		
16	5000159456	1	pc	Stopfen Tapón	Plug Bouchon		
17	5000159299	1	pc	Kupferscheibe Arandela de cobre	Copper washer Rondelle en cuivre		
18	5000215530	1	pc	Stopfen Enchufe	Plug Prise		
20	5000082183	1	pc	Dichtring Anillo sellador	Copper washer Rondelle à étancher		
20	5100054106	1	pc	Dichtung Junta	Seal Joint		
21	5100054107	1	pc	Thermoventil Válvula	Valve Soupape		
22	5100054105	6	pc	Buchse Buje	Bush Boîte		
23	5000155700	1	pc	Flansch Brida	Flange Colletette		
24	5000217807	1	pc	Dichtung Junta de estanqueidad	Gasket Garniture		
25	5000159467	6	pc	Schraube Tornillo	Screw Vis		
26	5000155701	1	pc	Wellendichtring Anillo de retén radial	Rotary shaft seal Bague d'étanchéité		
27	5000159341	1	pc	Ölfilterverschraubung Unión de filtro de aceite deaceite	Fitting-oil filter Raccord de filtre d'huile		
28	5100026398	1	pc	Ölfiltersatz Filtro de aceite	Oil filter Filtre d'huile		
29	5100026399	1	pc	Peilstab Varilla de aceite	Dip stick Barre d'observation		

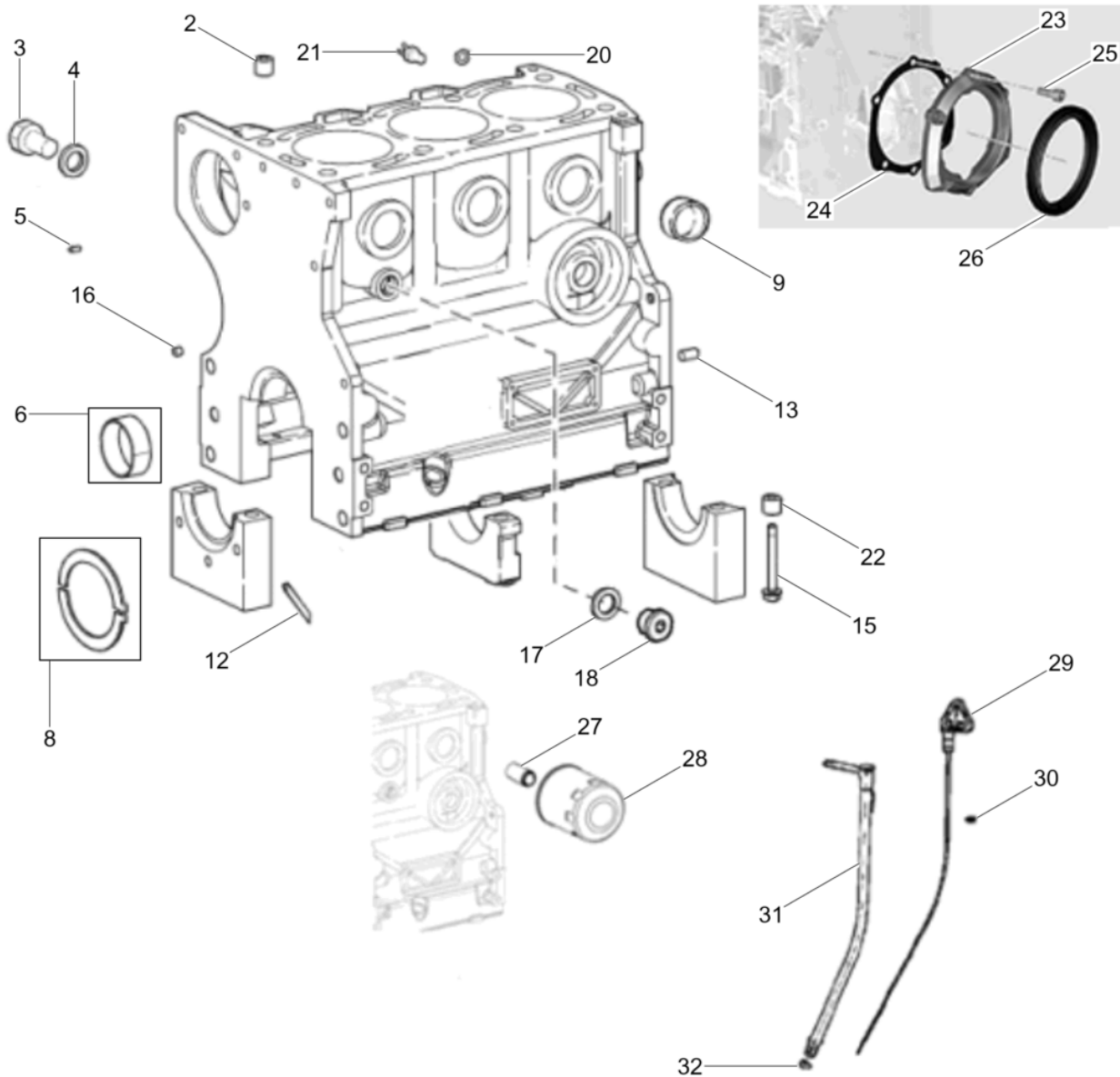

Pos. Item	Artikel Nr. Item no.	Pc.	Unit	Beschreibung Descripción	Description Description	Abm. Dim.	Norm Standard
						Drehmoment Torque	Schmierstoff Lubricant
30	5100026400	3	pc	O-Ring Anillo-o	O-ring Bague-o		
31	5100026401	1	pc	Rohr Tubo	Pipe Tube		
32	5000063695	2	pc	O-Ring Anillo-o	O-ring Joint torique		

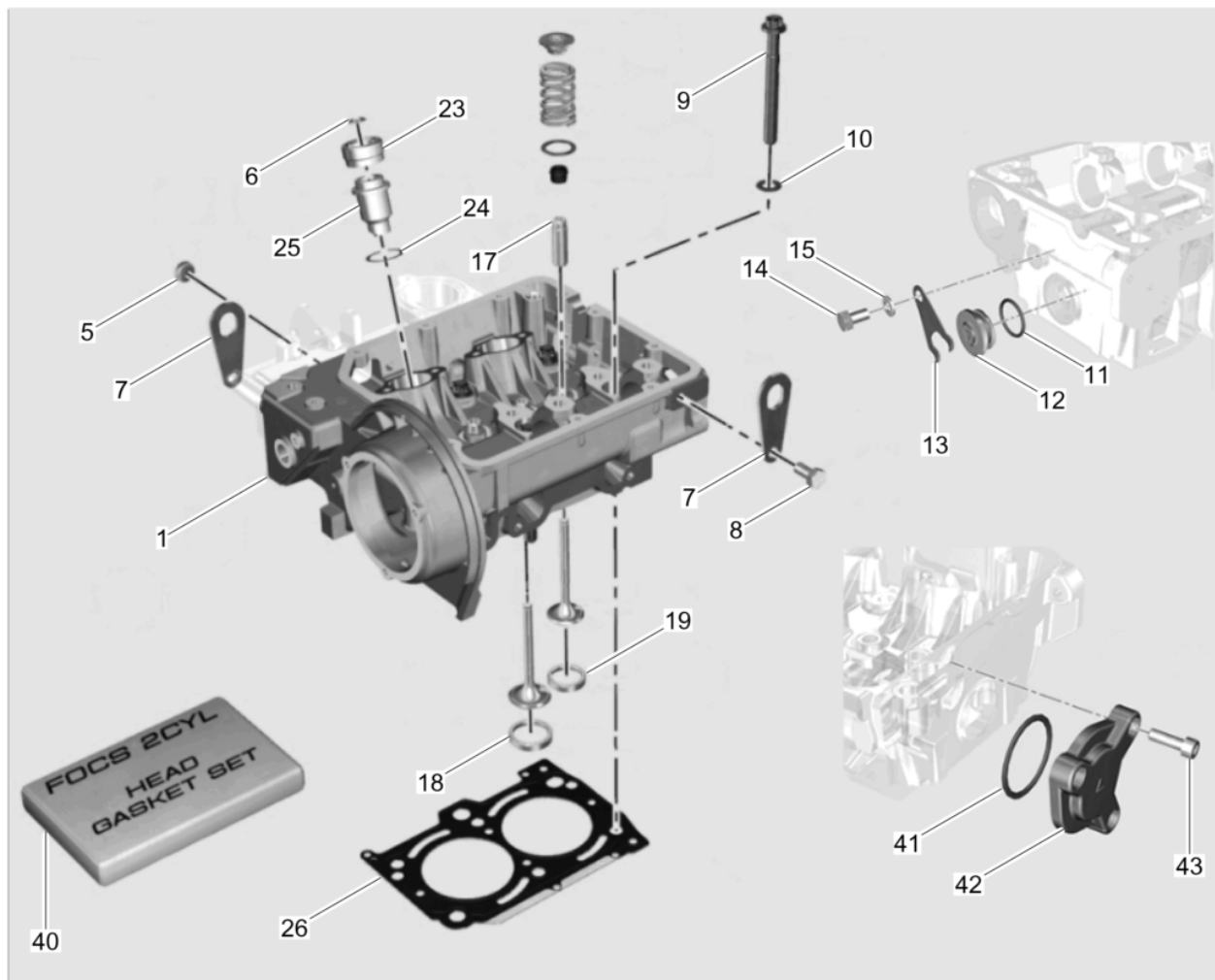

Pos. Item	Artikel Nr. Item no.	Pc.	Unit	Beschreibung Descripción	Description Description	Abm. Dim.	Norm Standard
						Drehmoment Torque	Schmierstoff Lubricant
1	5100026381	1	pc	Zylinderkopf Kpl. Culata cpl.	Cylinder head cpl. Culasse cpl.		
5	5000159449	1	pc	Stopfen Enchufe	Plug Prise		
6	5000159318	2	pc	Funkenfänger Parachispas	Spark arrester Pare-étincelles		
7	5000215524	2	pc	Aufhängung Punto para itar	Lifting point Suspension		
8	5000084156	1	pc	Schraube Tornillo	Screw Vis		
9	5000217828	6	pc	Flanschschraube Tornillo de brida	Flange screw Vis de bride		
10	5000159350	6	pc	Scheibe Arandela	Washer Rondelle		
11	5000159231	1	pc	O-Ring Anillo en forma de o	O-ring Joint torique		
12	5000159453	1	pc	Stopfen Enchufe	Plug Prise		
13	5000159311	1	pc	Halter Soporte	Bracket Équerre		
14	5000159254	1	pc	Bolzen Perno	Bolt Boulon		
15	5000082292	1	pc	Scheibe Arandela	Washer Rondelle		
17	5000159303	4	pc	Ventilführung Guía de válvula	Valve guide Guide de soupape		
18	5100026382	2	pc	Einlassventilsitz Asiento de válvula del product	Intake valve seat Siège de valve de prise		
19	5100026383	2	pc	Auslassventilsitz Asiento de la válvula de escap	Exhaust valve seat Siège de soupape d'échappement		
23	5000159285	2	pc	Mutter Tuerca	Nut Erou		
24	5000215494	6	pc	Abstandsstück Espaciador	Spacer Pièce d'écartement		
25	5000160380	2	pc	Vorkammer Cámara de precombustión	Precombustion chamber Préchambre		
26	5100026384	1	pc	Zylinderkopfdichtung Junta de culata del cilindro	Cylinder head gasket Joint de culasse de cylindre		
40	5200015510	1	pc	Dichtungssatz Zylinderkopf Juego de juntas culata	Gasket set cylinder head Jeu de joints culasse		
41	5000159234	1	pc	Öldichtung Junta de aceite	Oil seal Joint d'huile		
42	5000159282	1	pc	Flansch Brida	Flange Bride		
43	5000215541	3	pc	Schraube Tornillo	Screw Vis		

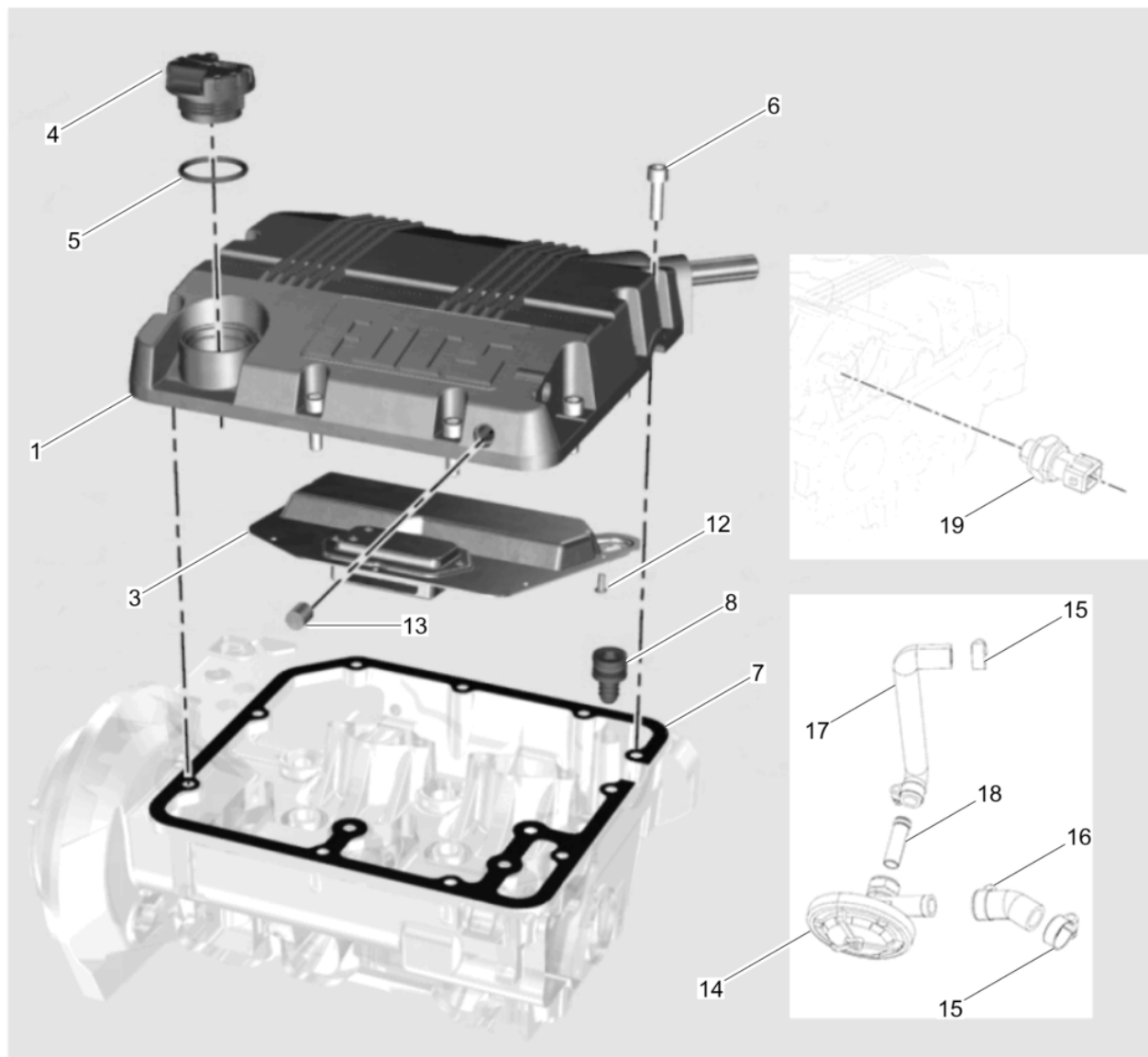

Pos. Item	Artikel Nr. Item no.	Pc.	Unit	Beschreibung Descripción	Description Description	Abm. Dim.	Norm Standard
						Drehmoment Torque	Schmierstoff Lubricant
1	5100026386	1	pc	Zylinderkopfdeckel Tapa del cilindro	Cylinder head cover Couvercle supérieur		
1	5100026387	1	pc	Gehäuse Carcasa	Housing Carter		
3	5100026388	1	pc	Trennblech Placa seperadora	Baffle plate Separateur		
4	5000227761	1	pc	Ölverschlussdeckel Tapa	Cap Couvercle		
5	5000206208	1	pc	O-Ring Anillo en forma de o	O-ring Joint torique		
6	5000215541	10	pc	Schraube Tornillo	Screw Vis		
7	5100026389	1	pc	Dichtung Junta	Gasket Joint		
8	5000159308	1	pc	Anschlußteil Conector	Connector Connexion		
12	5100008855	7	pc	Nietnagel Remache	Rivet Rivet		
13	5000159455	1	pc	Stopfen Tapón	Push-in plug Bouchon		
14	5000155745	1	pc	Überdruckventil Válvula de sobrepresión	Pressure valve Soupape de surpression		
15	5000160201	4	pc	Schelle Abrazadera	Clamp Attache		
16	5000215535	1	pc	Anschlussrohr Tubo, conexión	Connecting pipe Tube-branchement		
17	5000215505	1	pc	Anschlussrohr Tubo, conexión	Connecting tube Tube-branchement		
18	5000215536	1	pc	Ventilschlauch Tubo, válvula	Valve tube Tube, soupape		
19	5100006062	1	pc	Öldruckschalter Interruptor de presión de aceite	Oil pressure switch Interrupteur à pression		

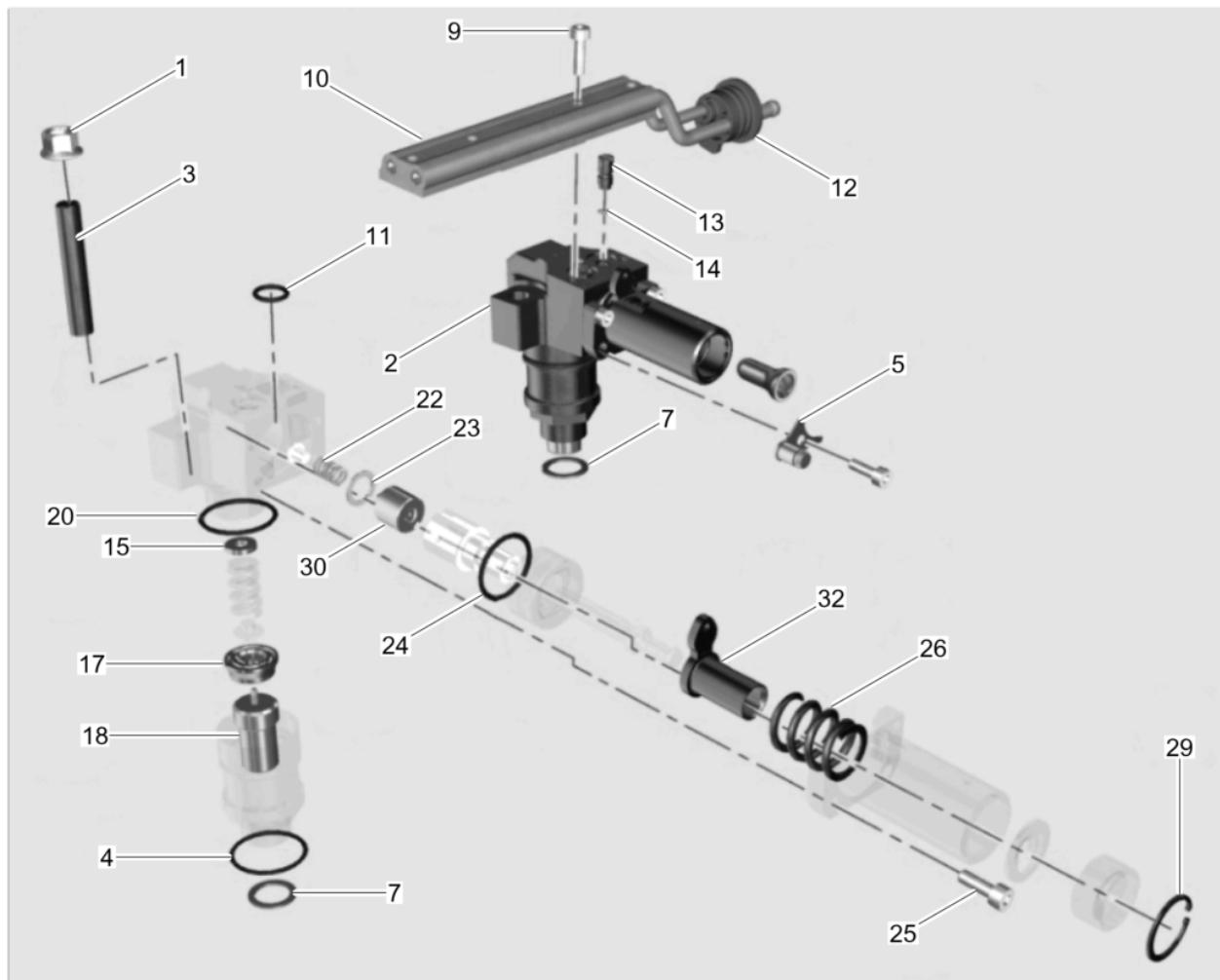

Pos. Item	Artikel Nr. Item no.	Pc.	Unit	Beschreibung Descripción	Description Description	Abm. Dim.	Norm Standard
						Drehmoment Torque	Schmierstoff Lubricant
1	5000203358	4	pc	Mutter Tuerca	Nut Écrou		
2	5000160379	2	pc	Einspritzpumpe Bomba de inyección	Injection pump Pompe à injection		
3	5200009479	4	pc	Gewindebolzen Perno prisionero	Stud Goujon		
4	5000159233	2	pc	O-Ring Anillo-o	O-ring Joint torique		
5	5100026390	1	pc	Halterung Soporte	Bracket Équerre		
7	5000159300	2	pc	Scheibe Disco	Washer Rondelle		
9	5000159473	4	pc	Schraube Tornillo	Screw Vis		
10	5100026391	1	pc	Kraftstoffschlauch Manguera de combustible	Fuel hose Tuyau à essence		
11	5000159237	2	pc	Ring Anillo	Ring Anneau		
12	5000160209	1	pc	Dichtung Junta de estanqueidad	Gasket Garniture		
13	5000160391	2	pc	Rückschlagventil Válvula de retención	Back pressure valve Soupape de retenue		
14	5000159302	2	pc	Dichtung Junta de estanqueidad	Gasket Garniture		
15	5000160332	1	pc	Abstandsstück Espaciador	Spacer Pièce d'écartement		
17	5000159278	2	pc	Abstandsstück Espaciador	Spacer Pièce d'écartement		
18	5100049824	2	pc	Einspritzdüse Inyector	Injection nozzle Injecteur		
20	5000159238	2	pc	O-Ring Anillo-o	O-ring Bague-o		
22	5000215509	2	pc	Feder Resorte	Spring Ressort		
23	5000203718	2	pc	Cu-Ring Cu-anillo	Cu-ring Cu-anneau		
24	5000159236	2	pc	Ring Anillo	Ring Anneau		
25	5000159471	4	pc	Schraube Tornillo	Screw Vis		
26	5000159317	2	pc	Feder Resorte	Spring Ressort		
29	5000159242	2	pc	Klemme Abrazadera	Clamp Pince		
30	5200015520	2	pc	Überdruckventil Válvula de sobrepresión	Pressure valve Soupape de surpression		
32	5000159309	2	pc	Ausgleichscheibe Laminata	Shim Cale		

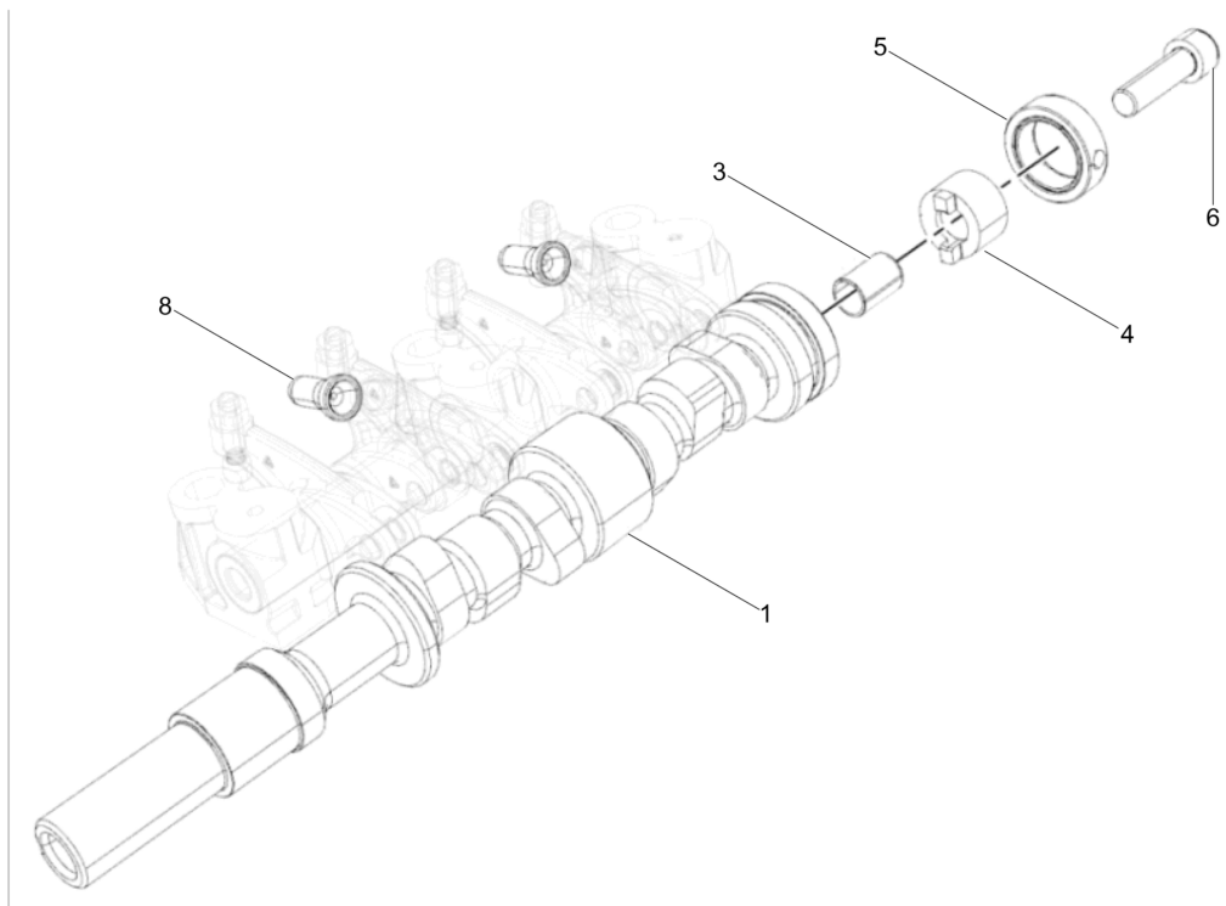

Pos. Item	Artikel Nr. Item no.	Pc.	Unit	Beschreibung Descripción	Description Description	Abm. Dim.	Norm Standard
						Drehmoment Torque	Schmierstoff Lubricant
1	5100026392	1	pc	Nockenwelle Arbol de levas	Camshaft Arbre à cames		
3	5000215482	1	pc	Hülse Collar	Collar Douille		
4	5000215497	1	pc	Nocken Leva	Cam Came		
5	5000160753	1	pc	Einspritznocken Leva inyectora	Injector cam Came d'injection		
6	5000215540	1	pc	Schraube Tornillo	Screw Vis		
8	5000159246	2	pc	Stoßstange Levantaválvula	Push rod (valve lifter) Poussoir de soupape		

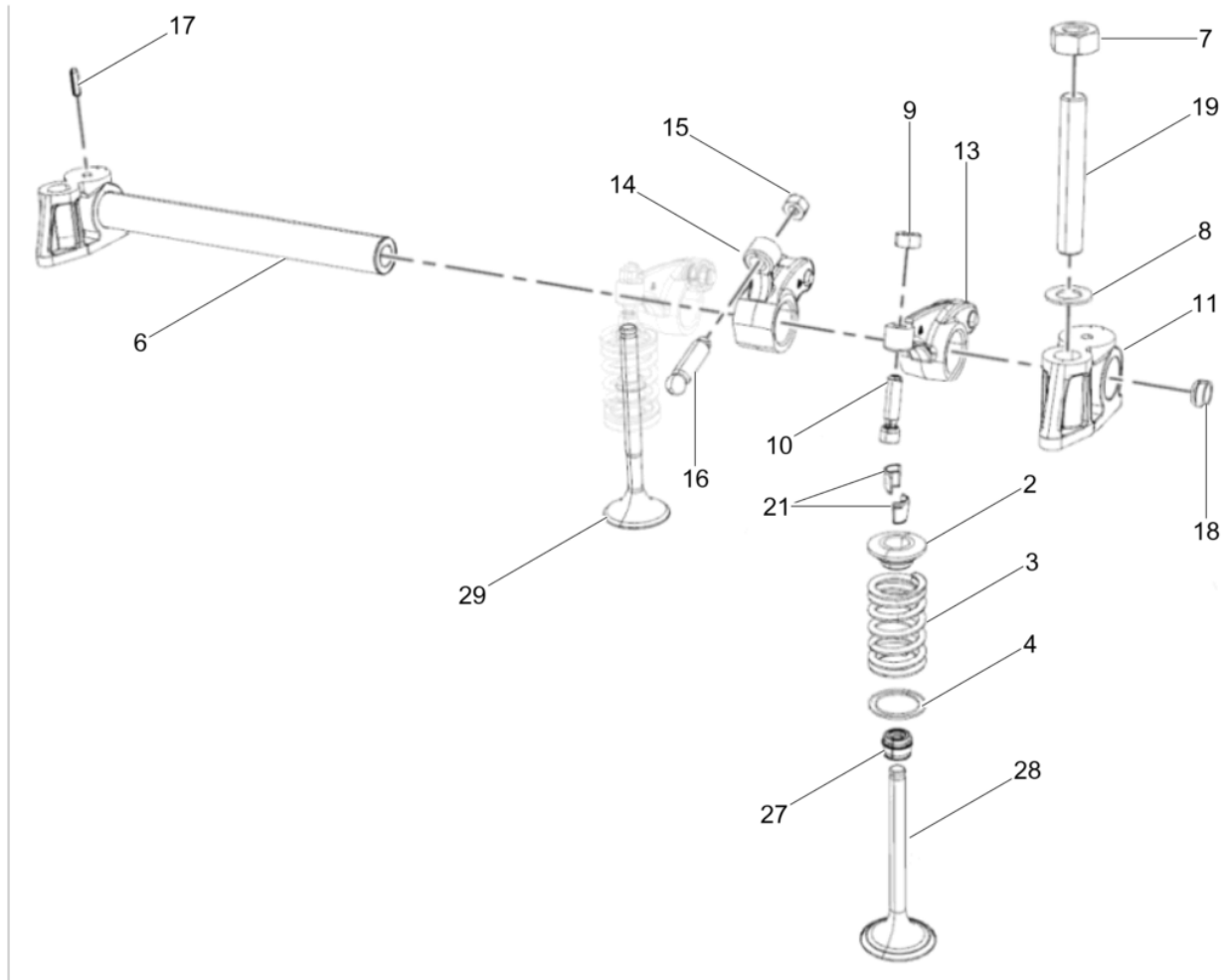

Pos. Item	Artikel Nr. Item no.	Pc.	Unit	Beschreibung Descripción	Description Description	Abm. Dim.	Norm Standard
						Drehmoment Torque	Schmierstoff Lubricant
2	5000159328	4	pc	Federgehäuse Carcasa de resorte	Spring housing Logement du ressort		
3	5000160373	4	pc	Ventilfeder Resorte	Spring Ressort		
4	5000159351	4	pc	Scheibe Disco	Washer Rondelle		
6	5100026393	1	pc	Kipphebel Kpl Balancín cpl.	Rocker arm cpl. Culbuteur cpl.		
6	5100026394	1	pc	Kipphebelstange Varilla	Rod Tringle		
7	5000083011	3	pc	Mutter Tuerca	Nut Ecrou		
8	5000159350	3	pc	Scheibe Arandela	Washer Rondelle		
9	5000159272	1	pc	Mutter Tuerca	Nut Écrou		
10	5000159482	1	pc	Schraube Tornillo	Screw Vis		
11	5000159447	3	pc	Kipphebelbolzenkonsole Soporte del eje de balancín	Shaft support Support de l'arbre de bascule		
13	5000159248	4	pc	Kipphebel Balancín	Rocker arm Culbuteur		
14	5000159249	2	pc	Kipphebel Einspritzdüse Inyector de balancines	Rocker arm injector L'injecteur de culbuteur		
15	5000159275	1	pc	Mutter Tuerca	Nut Ecrou		
16	5000159483	1	pc	Gewindebolzen Perno roscado	Threaded bolt Boulon fileté		
17	5000159443	1	pc	Stift Espiga	Pin Goupille		
18	5000215529	2	pc	Stopfen Enchufe	Plug Prise		
19	5000159333	3	pc	Gewindebolzen Perno roscado	Threaded stud Boulon fileté		
21	5100008856	8	pc	Buchse Buje	Bush Boîte		
27	5000159297	4	pc	Dichtung Junta	Gasket Joint		
28	5000160390	2	pc	Einlaßventil Válvula de admisión	Intake valve Soupape d'admission		
29	5000160392	2	pc	Auslaßventil Válvula de escape	Outlet valve Soupape d'échappement		

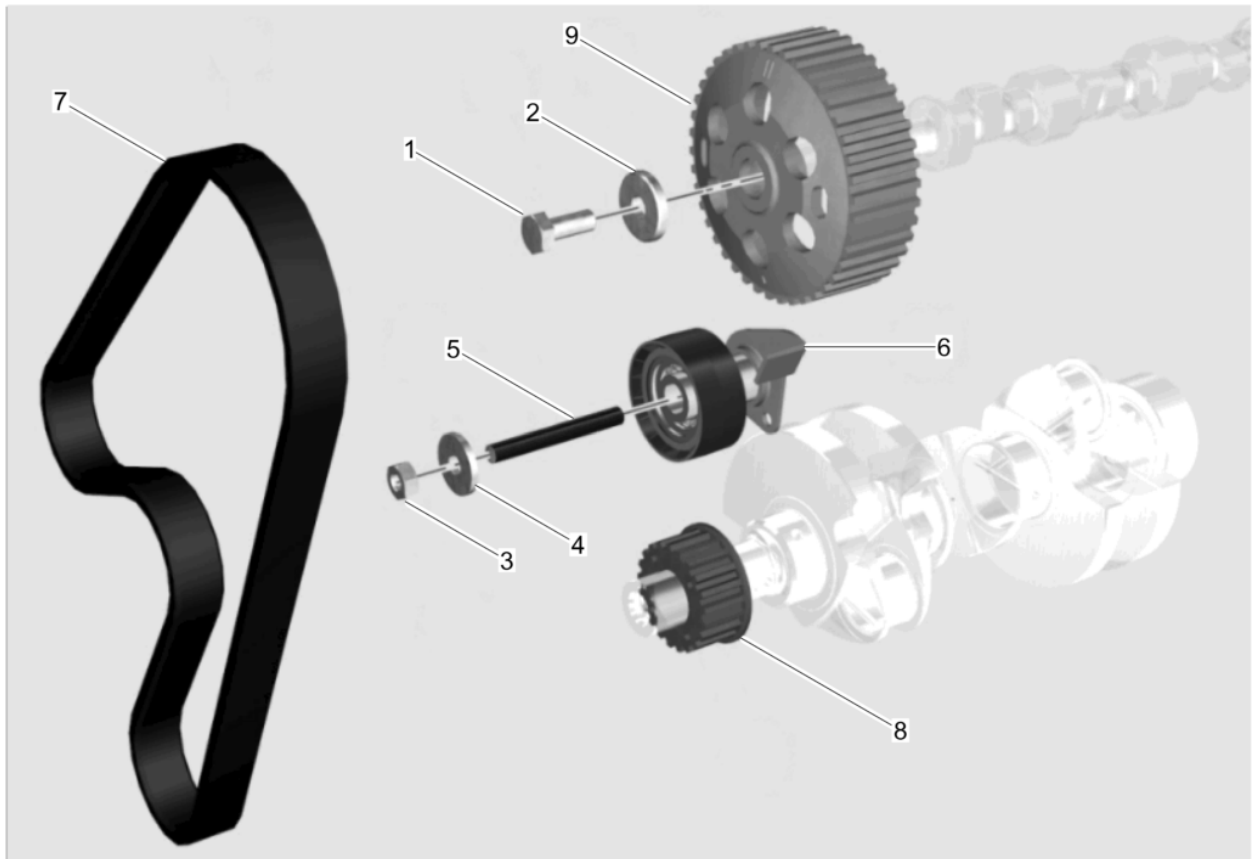

Pos. Item	Artikel Nr. Item no.	Pc.	Unit	Beschreibung Descripción	Description Description	Abm. Dim.	Norm Standard
						Drehmoment Torque	Schmierstoff Lubricant
1	5000159481	1	pc	Schraube Tornillo	Screw Vis		
2	5000159349	1	pc	Scheibe Disco	Washer Rondelle		
3	5000083011	1	pc	Mutter Tuerca	Nut Ecrou		
4	5000159344	1	pc	Scheibe Disco	Washer Rondelle		
5	5000159334	1	pc	Gewindebolzen Perno roscado	Threaded stud Boulon fileté		
6	5000159284	1	pc	Spannrolle Polea tensora	Tensioner pulley Poulie de tension		
7	5000155697	1	pc	Synchronriemen Correa de sincronización	Timing belt Courroie de synchronisation		
8	5000159336	1	pc	Riemenscheibe Polea	Belt pulley Poulie		
9	5000159338	1	pc	Riemenscheibe Polea	Belt pulley Poulie		

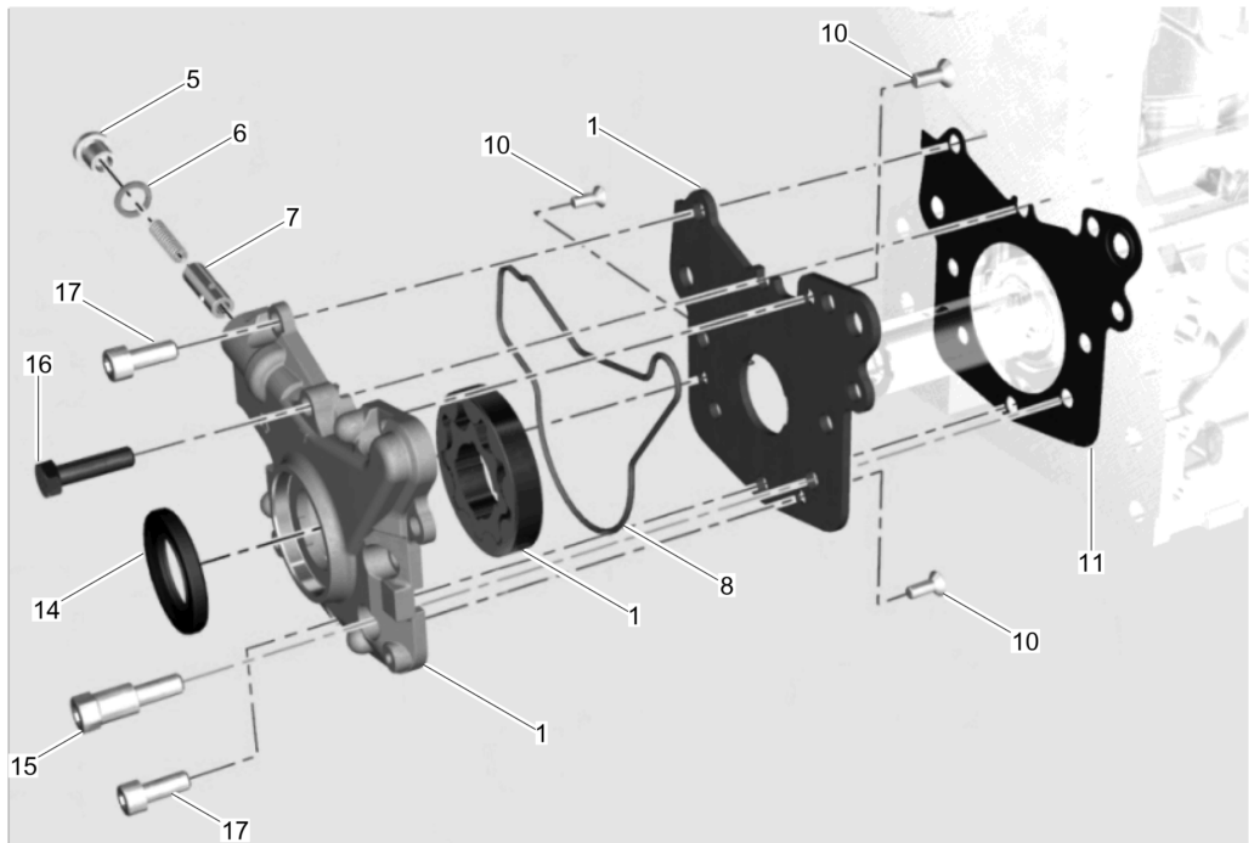

Pos. Item	Artikel Nr. Item no.	Pc.	Unit	Beschreibung Descripción	Description Description	Abm. Dim.	Norm Standard
						Drehmoment Torque	Schmierstoff Lubricant
1	5100049825	1	pc	Ölpumpe Bomba de aceite	Oil pump Pompe à huile		
5	5000159450	1	pc	Schraubverschluß Cierre roscada	Screw locking Fermeture de vissage		
6	5000082184	1	pc	Dichtring Anillo sellador	Ring seal Rondelle à étancher		
7	5000159330	1	pc	Stange Varilla	Rod Tige		
8	5000160178	1	pc	O-Ring Anillo-o	O-ring Joint torique		
10	5000159478	3	pc	Schraube Tornillo	Screw Vis		
11	5200009506	1	pc	Dichtung Junta	Gasket Joint		
14	5000155734	1	pc	Dichtungsring Anillo sellador	Ring seal Rondelle à étancher		
15	5000159484	2	pc	Schraube Tornillo	Screw Vis		
16	5000215479	1	pc	Sechskantschraube Tornillo de cabeza hexagonal	Hexagonal head cap screw Vis à tête hexagonale		
17	5000084169	6	pc	Schraube Tornillo	Screw Vis		

Ölwanne
Oil pan
Carter de aceite
Cuvette carter à huile

DPU80rLem670

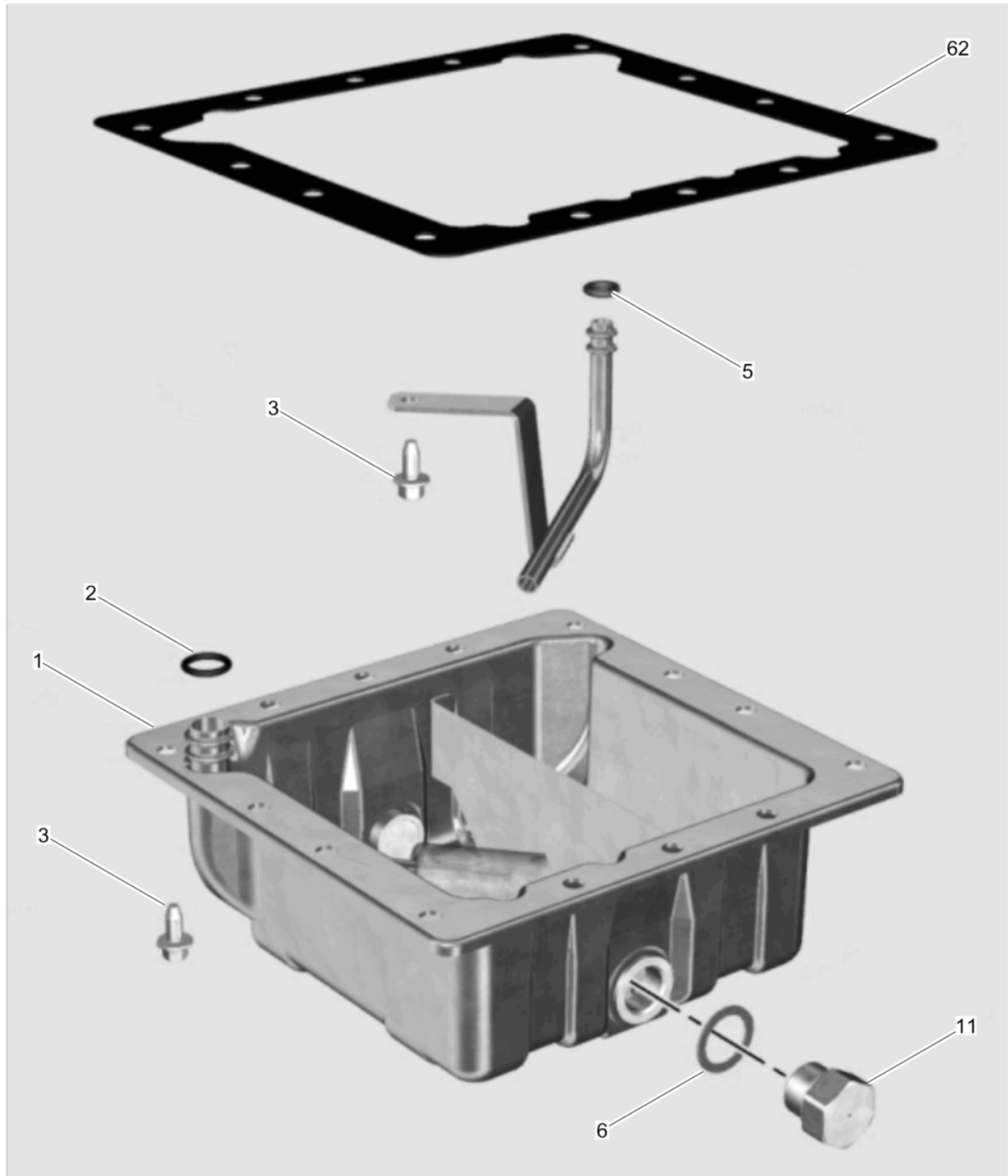

Pos. Item	Artikel Nr. Item no.	Pc.	Unit	Beschreibung Descripción	Description Description	Abm. Dim.	Norm Standard
						Drehmoment Torque	Schmierstoff Lubricant
1	5100054108	1	pc	Ölwanne Carter de aceite	Oil pan Cuvette carter à huile		
2	5000159228	1	pc	Öldichtung Junta de aceite	Oil seal Joint d'huile		
3	5000159253	15	pc	Bolzen Perno	Bolt Boulon		
5	5000159235	1	pc	O-Ring Anillo-o	O-ring Joint torique		
6	5000159568	2	pc	Kupferscheibe Anillo de cobre	Copper washer Rondelle en cuivre		
11	5000211364	2	pc	Verschlusschraube Tapón roscado	Screw plug Vis de fermeture		
62	5100026397	1	pc	Dichtung Junta	Gasket Joint		

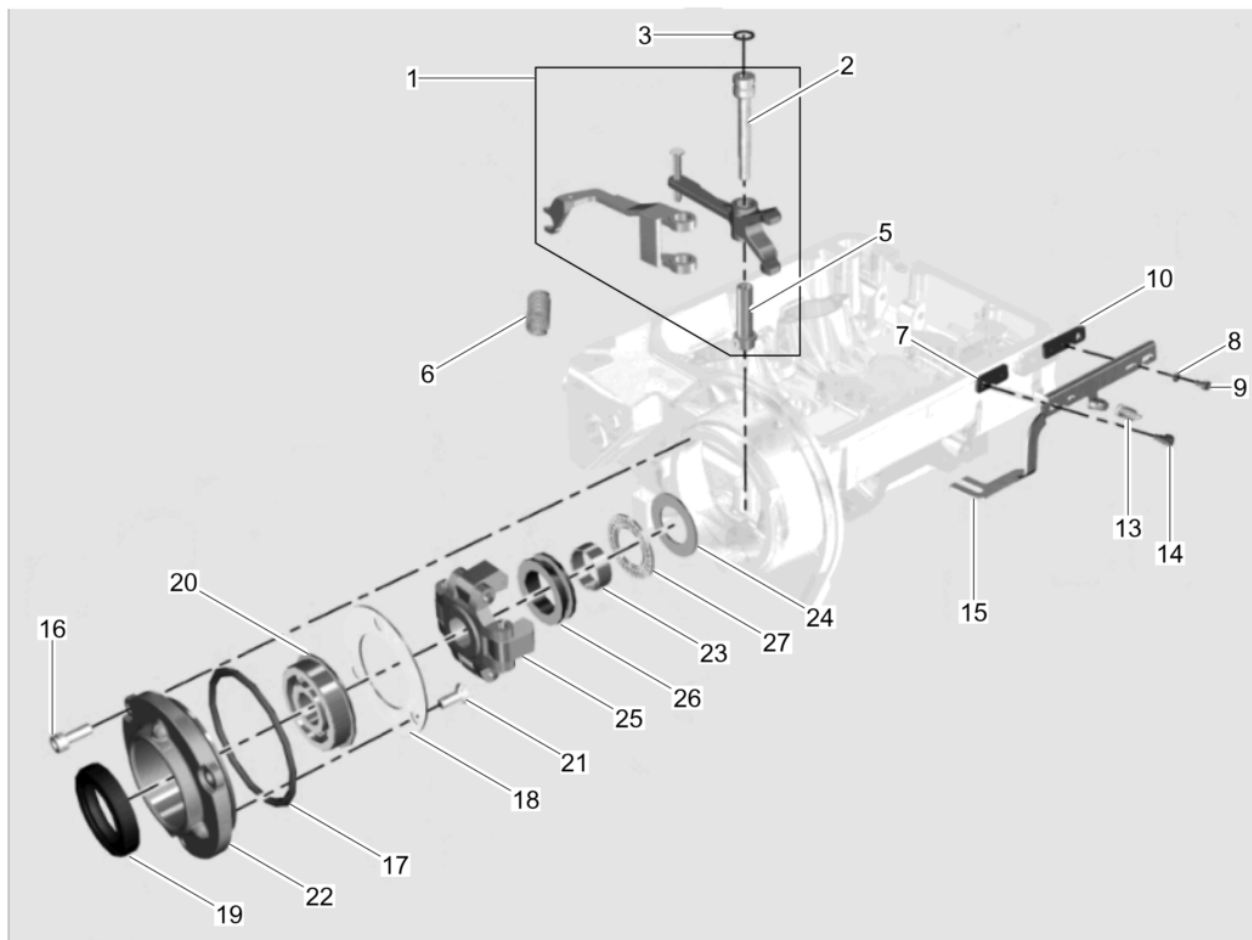

Pos. Item	Artikel Nr. Item no.	Pc.	Unit	Beschreibung Descripción	Description Description	Abm. Dim.	Norm Standard
						Drehmoment Torque	Schmierstoff Lubricant
1	5000159304	1	pc	Reglerhebel Kpl. Palanca de regulador cpl.	Governor lever cpl. Lever régulateur cpl.		
2	5000159321	1	pc	Stift Espiga	Pin Goupille		
3	5000159229	1	pc	Öldichtung Junta de aceite	Oil seal Joint d'huile		
4	5000063681	1	pc	Wellendichtring Sello del eje	Shaft seal Bague d'étanchéité		
5	5000215480	1	pc	Hülse Collar	Collar Douille		
6	5000215507	1	pc	Feder Resorte	Spring Ressort		
7	5000217813	1	pc	Platte Placa	Plate Plaque		
8	5000215520	2	pc	Scheibe Disco	Washer Rondelle		
9	5000159477	2	pc	Schraube Tornillo	Screw Vis		
10	5000215721	1	pc	Platte Placa	Plate Plaque		
13	5000159315	1	pc	Feder Resorte	Spring Ressort		
14	5000211941	2	pc	Schraube Tornillo	Screw Vis		
15	5100026402	1	pc	Reglerstange Varillaje de regulación	Governor rod Tige de régulateur		
16	5000159467	3	pc	Schraube Tornillo	Screw Vis		
17	5000159239	1	pc	O-Ring Anillo-o	O-ring Joint torique		
18	5000159324	1	pc	Anlaufscheibe Arandela tope	Check disc Disque		
19	5000159240	1	pc	Lippendichtung Retén labial	Lip seal Joint à lèvres		
20	5000159267	1	pc	Lager Rodamiento	Bearing Roulement		
21	5100008841	3	pc	Schraube Tornillo	Screw Vis		
22	5000159265	1	pc	Deckel Cubierta	Cover Couvercle		
23	5000159251	1	pc	Hülse Collar	Collar Douille		
24	5000215517	1	pc	Anlaufscheibe Arandela tope	Check disc Disque		
25	5000155698	1	pc	Drehzahlregler Controlador de velocidad	Speed control module Régulateur de vitesse		
26	5000215506	1	pc	Hülse Collar	Collar Douille		
27	5000217805	1	pc	Anlauflager Cojinete	Bearing Palier		

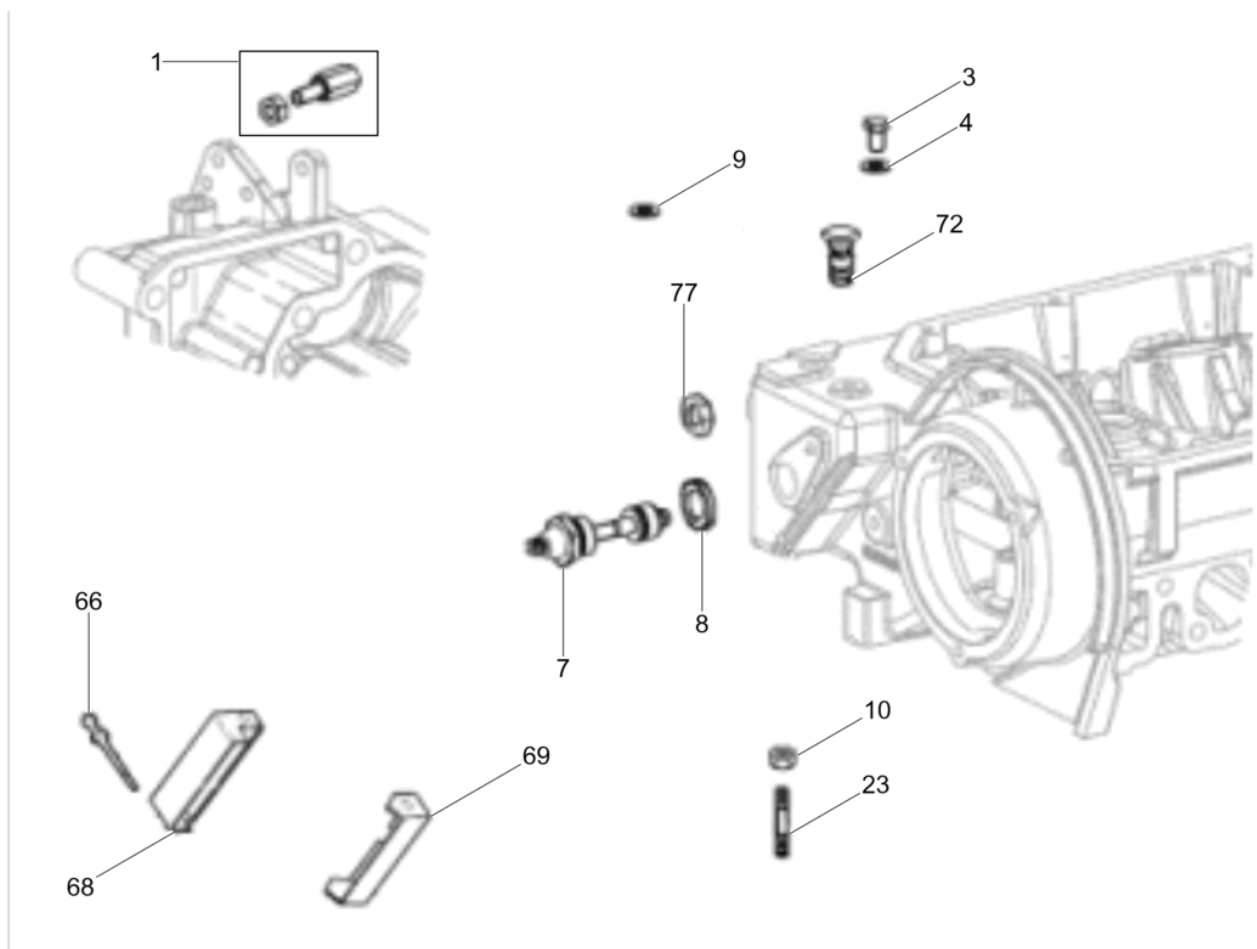

Pos. Item	Artikel Nr. Item no.	Pc.	Unit	Beschreibung Descripción	Description Description	Abm. Dim.	Norm Standard
						Drehmoment Torque	Schmierstoff Lubricant
1	5000209040	1	pc	Einstellschraube Tornillo	Screw Vis		
3	5000084131	2	pc	Schraube Tornillo	Screw Vis		
4	5000083995	2	pc	Scheibe Arandela	Washer Rondelle		
7	5000215525	1	pc	Kraftstoffhahn Grifo de combustible	Fuel valve Robinet de carburant		
8	5000159292	1	pc	Dichtung Junta de estanqueidad	Gasket Garniture		
9	5000082291	1	pc	Scheibe Arandela	Washer Rondelle		
10	5000159272	1	pc	Mutter Tuerca	Nut Écrou		
10	5000209012	1	pc	Sechskantmutter Tuerca hexagonal	Hexagon nut Écrou hexagonal	M6	
23	5100042199	1	pc	Gewindebolzen Perno prisionero	Stud Goujon	M6 x 16	
66	5000215519	3	pc	Niet Remache	Rivet Rivet		
68	5100049828	1	pc	Platte Placa	Plate Plaque		
69	5100049827	1	pc	Platte Placa	Plate Plaque		
72	5000215528	1	pc	Stopfen Tapón	Plug Bouchon		
77	5000159276	1	pc	Mutter Tuerca	Nut Écrou		

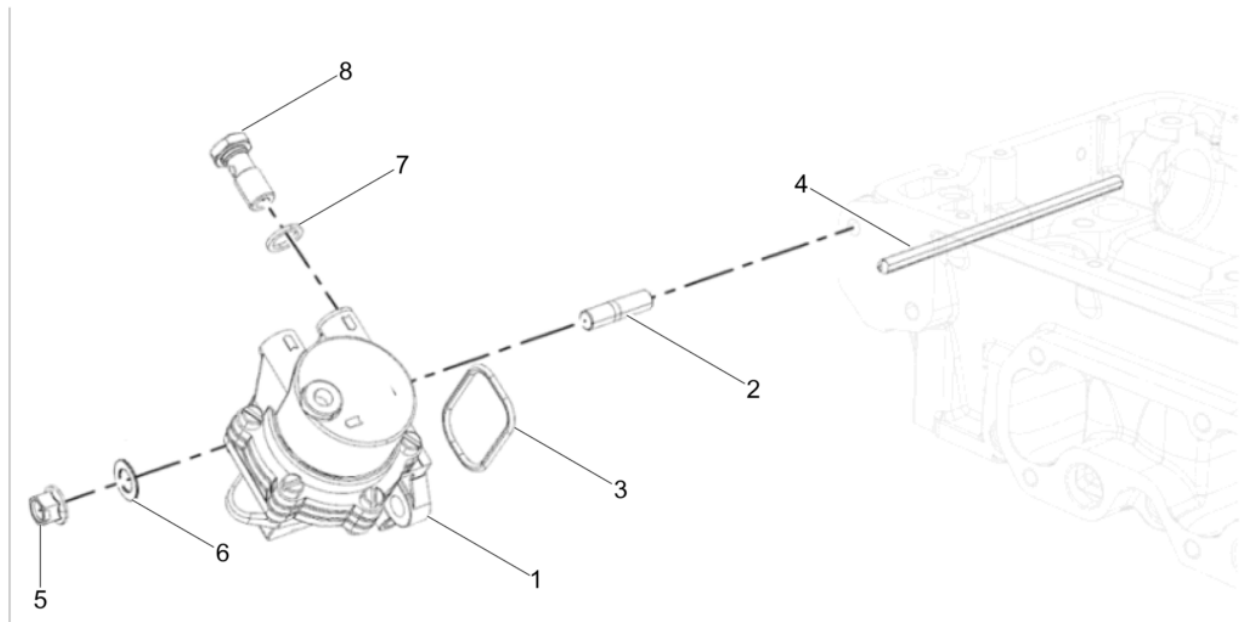

Pos. Item	Artikel Nr. Item no.	Pc.	Unit	Beschreibung Descripción	Description Description	Abm. Dim.	Norm Standard
						Drehmoment Torque	Schmierstoff Lubricant
1	5000226239	1	pc	Kraftstoffpumpe Bomba de combustible	Fuel pump Pompe à essence		
2	5000082266	2	pc	Stiftschraube Perno prisionero	Stud Boulon		
3	5000110759	1	pc	Dichtung Junta	Seal Joint		
4	5000160757	1	pc	Stange Varillae	Rod Tige		
5	5200016512	2	pc	Flanschmutter Tuerca de reborde	Flange nut Ecrou de bride		
6	5000082285	2	pc	Scheibe Arandela	Washer Rondelle		
7	5000082183	4	pc	Dichtring Anillo sellador	Copper washer Rondelle à étancher		
8	5000217802	2	pc	Hohlschraube Perno hueco	Banjo bolt Boulon creux à filet femelle		

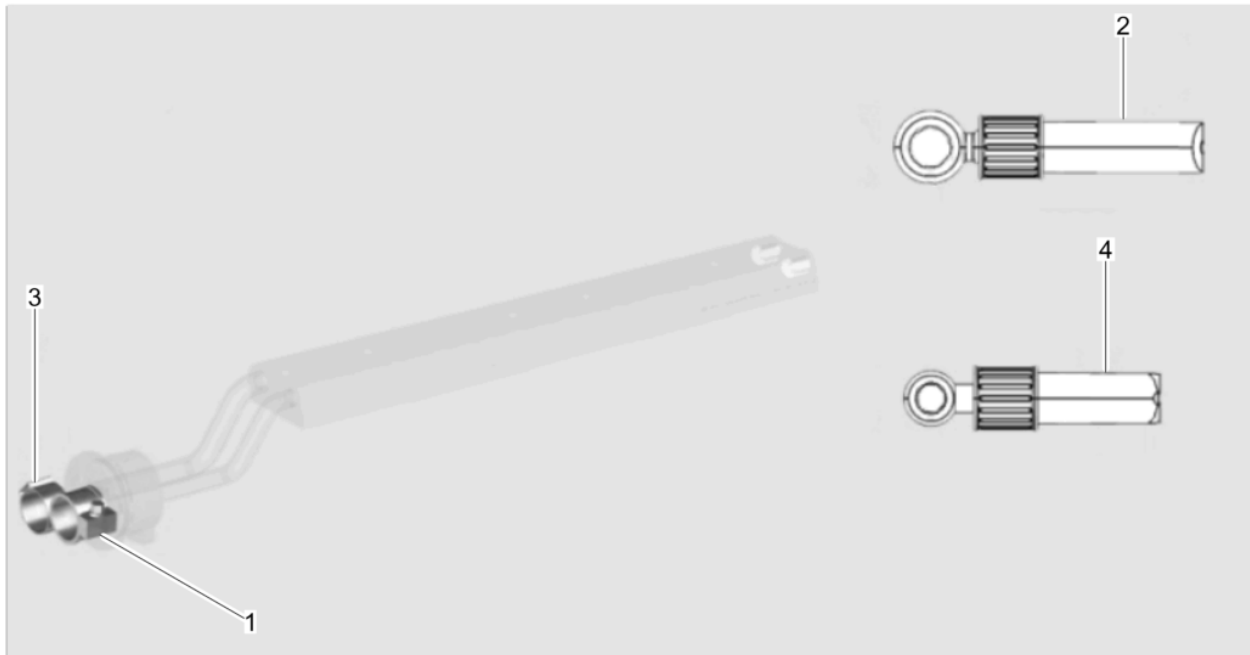

Pos. Item	Artikel Nr. Item no.	Pc.	Unit	Beschreibung Descripción	Description Description	Abm. Dim.	Norm Standard
						Drehmoment Torque	Schmierstoff Lubricant
1	5000082155	1	pc	Schelle Abrazadera	Clamp Collier		
2	5100026403	1	pc	Kraftstoffschlauch Manguera de combustible	Fuel hose Tuyau à essence		
3	5000215704	1	pc	Schelle Abrazadera	Clamp Attache		
4	5100026404	1	pc	Kraftstoffschlauch Manguera de combustible	Fuel hose Tuyau à essence		

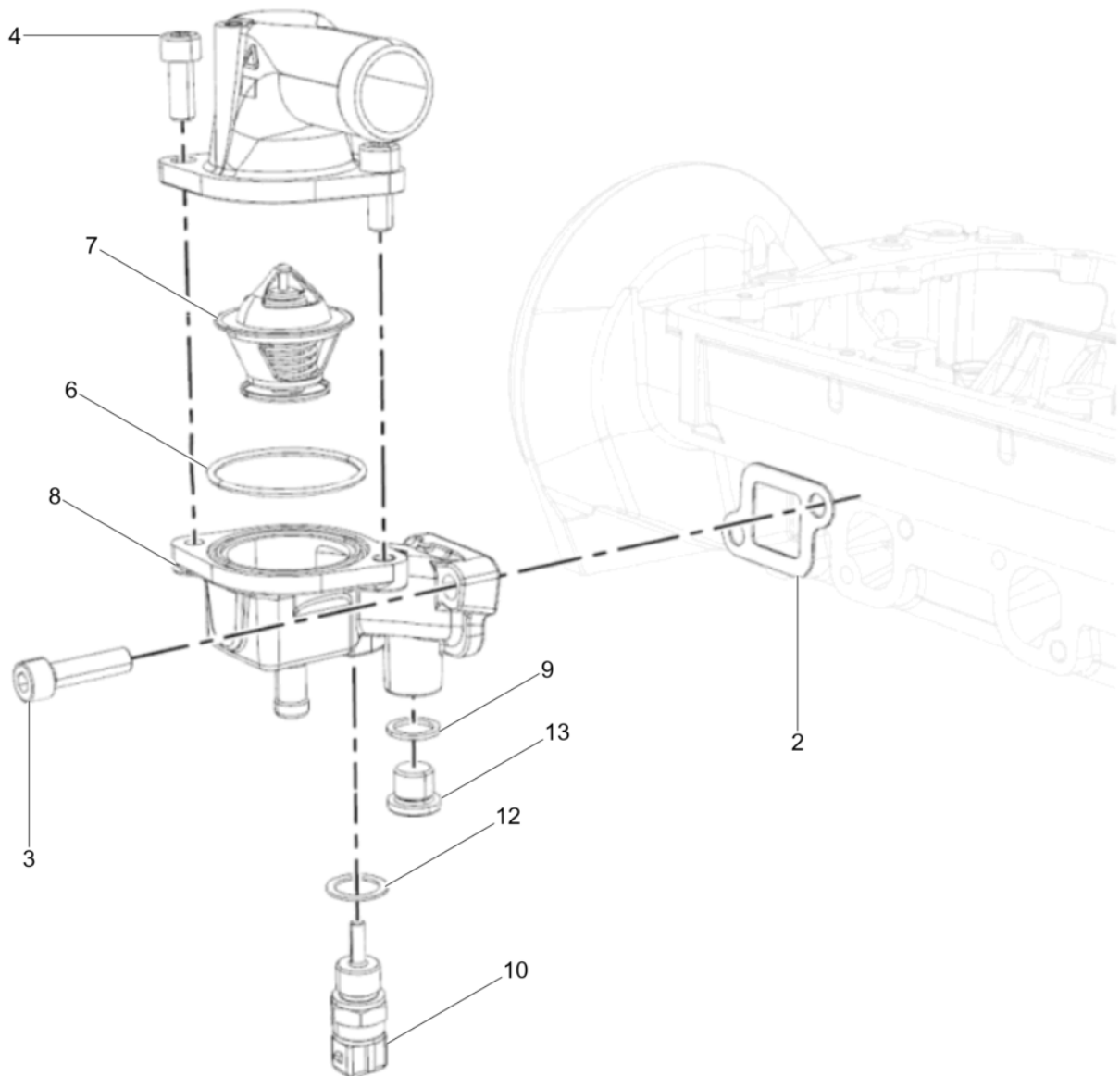

Pos. Item	Artikel Nr. Item no.	Pc.	Unit	Beschreibung Descripción	Description Description	Abm. Dim.	Norm Standard
						Drehmoment Torque	Schmierstoff Lubricant
2	5000211378	1	pc	Dichtung Junta de estanqueidad	Gasket Garniture		
3	5000159476	2	pc	Schraube Tornillo	Screw Vis		
4	5000084169	2	pc	Schraube Tornillo	Screw Vis		
6	5000159232	1	pc	O-Ring Anillo-o	O-ring Joint torique		
7	5000207002	1	pc	Thermostatventil Válvula de gobierno termostático	Valve-thermostat Soupape thermostatique		
8	5000215489	1	pc	Temperaturreglergehäuse Caja del termóstato	Thermostat housing Carter du thermostat		
9	5200016500	1	pc	Kupferscheibe Arandela de cobre	Copper washer Rondelle en cuivre		
10	5100005738	1	pc	Temperaturfühler Elemento térmico	Temperature sensor Décteur thermique		
12	5000159299	1	pc	Kupferscheibe Arandela de cobre	Copper washer Rondelle en cuivre		
13	5000159451	1	pc	Verschlusschraube Tapón roscado	Screw plug Vis de fermeture		

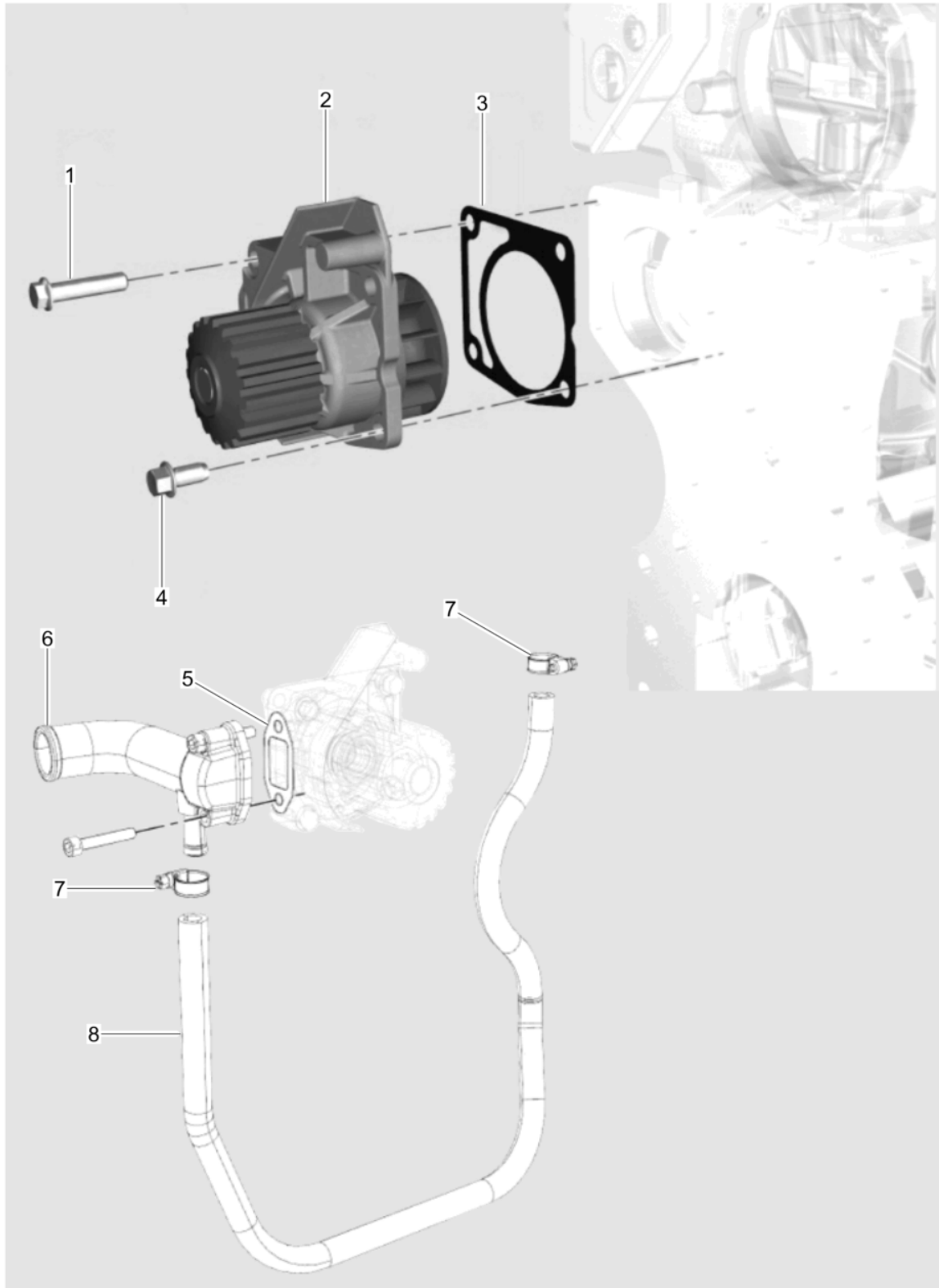

Pos. Item	Artikel Nr. Item no.	Pc.	Unit	Beschreibung Descripción	Description Description	Abm. Dim.	Norm Standard
						Drehmoment Torque	Schmierstoff Lubricant
1	5000209105	2	pc	Sechskantschraube Tornillo hexagonal	Hexagonal head cap screw Vis à tête hexagonale		
2	5100026407	1	pc	Wasserpumpe Bomba de agua	Water pump Pompe d'eau		
3	5000217809	1	pc	Dichtung Junta de estanqueidad	Gasket Garniture		
4	5000209107	2	pc	Sechskantschraube Tornillo hexagonal	Hexagonal head cap screw Vis à tête hexagonale		
5	5000217808	1	pc	Dichtung Junta de estanqueidad	Gasket Garniture		
6	5100026405	1	pc	Flansch Brida	Flange Bride		
7	5000160201	2	pc	Schelle Abrazadera	Clamp Attache		
8	5100026406	1	pc	Schlauch Manguera	Hose Tuyau		

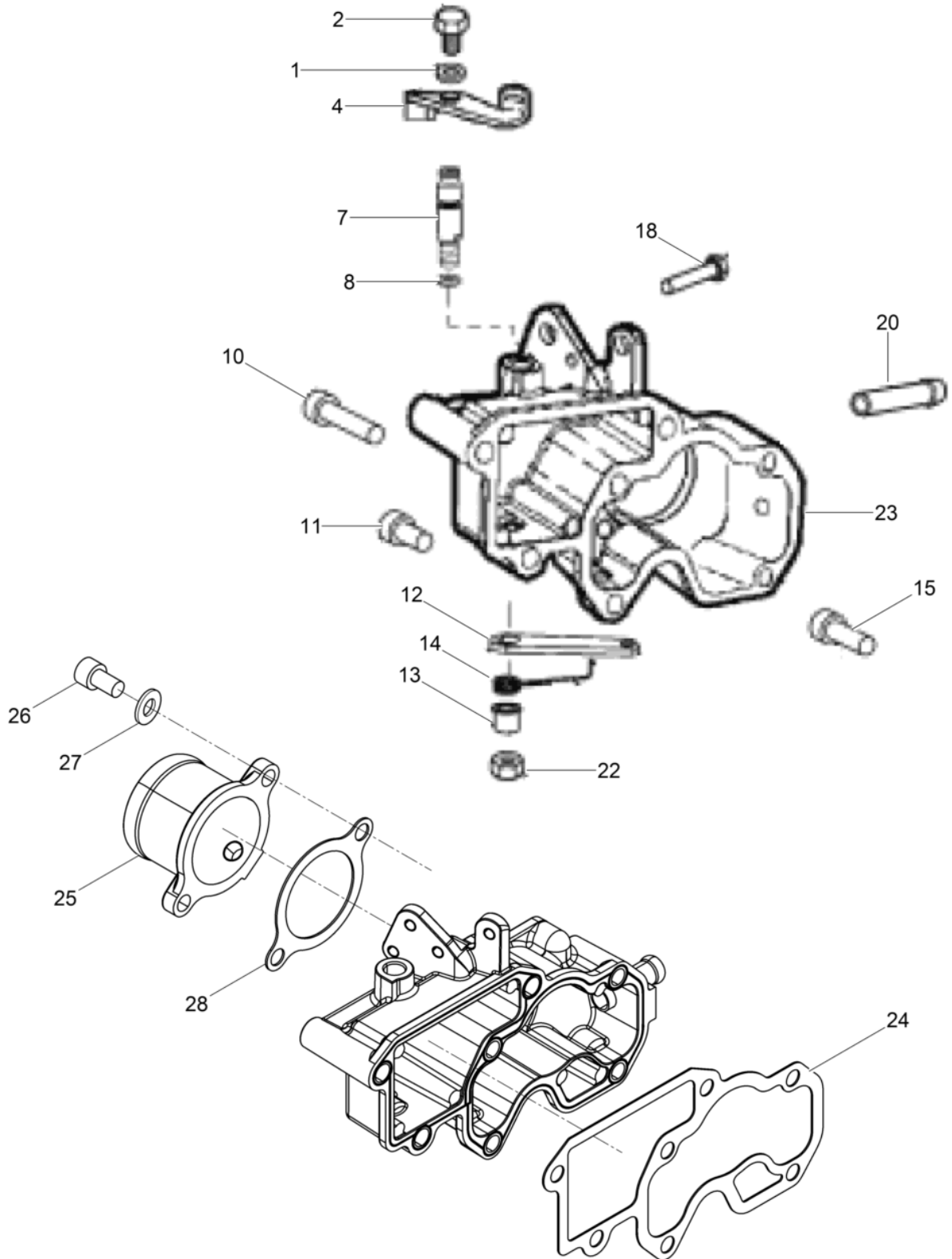

Pos. Item	Artikel Nr. Item no.	Pc.	Unit	Beschreibung Descripción	Description Description	Abm. Dim.	Norm Standard
						Drehmoment Torque	Schmierstoff Lubricant
1	5000217817	1	pc	Scheibe Disco	Washer Rondelle		
2	5000217801	1	pc	Sechskantschraube Tornillo hexagonal	Hexagonal head cap screw Vis à tête hexagonale		
4	5100026408	1	pc	Hebel Palanca	Lever Levier		
7	5100008860	1	pc	Welle Eje	Shaft Arbre		
8	5000159230	1	pc	Öldichtung Junta de aceite	Oil seal Joint d'huile		
10	5000084170	1	pc	Schraube Tornillo	Screw Vis		
11	5000159476	2	pc	Schraube Tornillo	Screw Vis		
12	5000215504	1	pc	Hebel Palanca	Lever Levier		
13	5000215481	1	pc	Hülse Collar	Collar Douille		
14	5000215508	1	pc	Feder Resorte	Spring Ressort		
15	5000203346	3	pc	Schraube Tornillo	Screw Vis		
20	5000159462	1	pc	Schlauch Manguera	Hose Boyau		
22	5000084232	1	pc	Mutter Tuerca	Nut Ecrou		
23	5100026409	1	pc	Verteiler Distribuidor	Manifold Tubulure		
23	5100026409	1	pc	Verteiler Distribuidor	Manifold Tubulure		
24	5100026410	1	pc	Dichtung Junta	Gasket Joint		
25	5100026411	1	pc	Flansch Brida	Flange Bride		
26	5000084169	2	pc	Schraube Tornillo	Screw Vis		
27	5000082285	2	pc	Scheibe Arandela	Washer Rondelle		
28	5100026429	1	pc	Dichtung Junta	Gasket Joint		

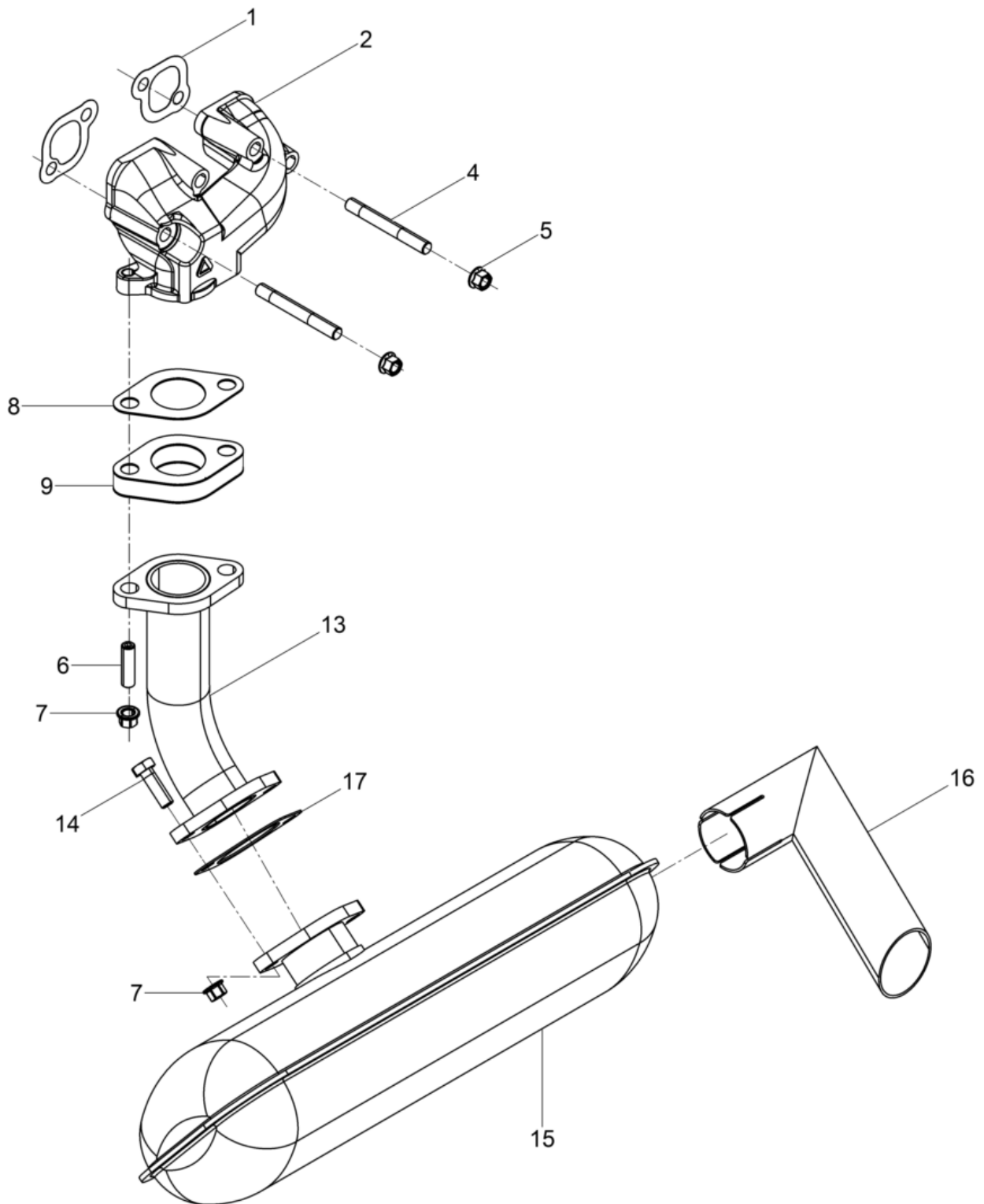

Pos. Item	Artikel Nr. Item no.	Pc.	Unit	Beschreibung Descripción	Description Description	Abm. Dim.	Norm Standard
						Drehmoment Torque	Schmierstoff Lubricant
1	5000159290	2	pc	Dichtung Junta de estanqueidad	Gasket Garniture		
2	5100026412	1	pc	Auspuffkrümmer Múltiple de escape	Exhaust manifold Coude d'échappement		
4	5000082267	4	pc	Gewindebolzen Perno prisionero	Stud Boulon		
5	5000086331	4	pc	Mutter Tuerca	Nut Écrou		
6	5000160228	2	pc	Gewindebolzen Perno roscado	Threaded bolt Boulon fileté	M8x22	
7	5000086331	4	pc	Mutter Tuerca	Nut Écrou		
8	5000159295	1	pc	Dichtung Junta de estanqueidad	Gasket Garniture		
9	5100026413	1	pc	Flansch Brida	Flange Bride		
13	5100005700	1	pc	Auspuffrohr Tubo de escape	Exhaust pipe Tube d'échappement		
14	5000215479	2	pc	Sechskantschraube Tornillo de cabeza hexagonal	Hexagonal head cap screw Vis à tête hexagonale		
15	5100005522	1	pc	Schalldämpfer Silenciador	Muffler Silencieux		
16	5100005702	1	pc	Auspuffendrohr Extremo de la extractor-pipa	Exhaust-pipe end Extrémité de échappement-pipe		
17	5100041970	1	pc	Dichtung Junta de estanqueidad	Gasket Garniture		

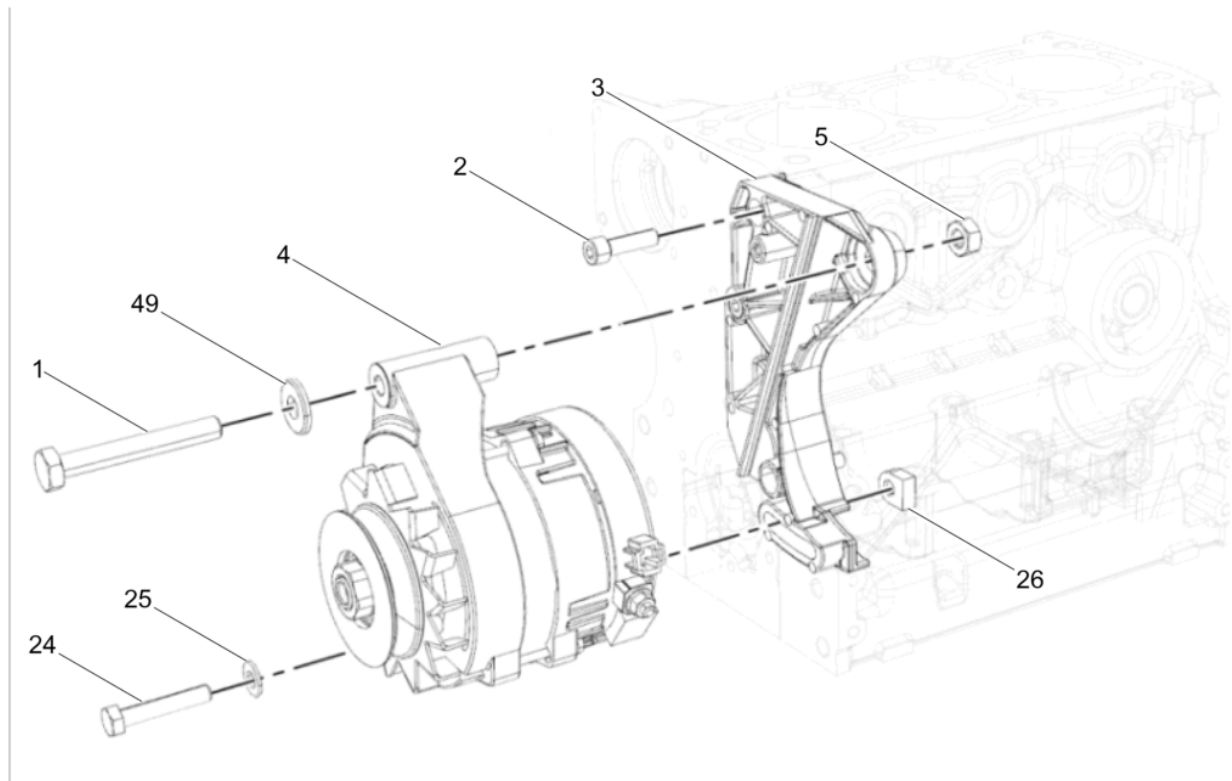

Pos. Item	Artikel Nr. Item no.	Pc.	Unit	Beschreibung Descripción	Description Description	Abm. Dim.	Norm Standard
						Drehmoment Torque	Schmierstoff Lubricant
1	5100026414	1	pc	Sechskantschraube Tornillo hexagonal	Hexagonal head cap screw Vis à tête hexagonale		
2	5000159476	3	pc	Schraube Tornillo	Screw Vis		
3	5100026415	1	pc	Halterung Soporte	Bracket Équerre		
4	5100026416	1	pc	Lichtmaschine Alternador	Alternator Alternateur		
5	5000083011	1	pc	Mutter Tuerca	Nut Ecrou		
24	5000208993	1	pc	Sechskantschraube Tornillo hexagonal	Hexagonal head cap screw Vis à tête hexagonale		
25	5000082293	1	pc	Scheibe Arandela	Washer Rondelle		
26	5100026417	1	pc	Klemme Abrazadera	Clamp Pince		
49	5100026418	1	pc	Scheibe Disco	Disc Disque		

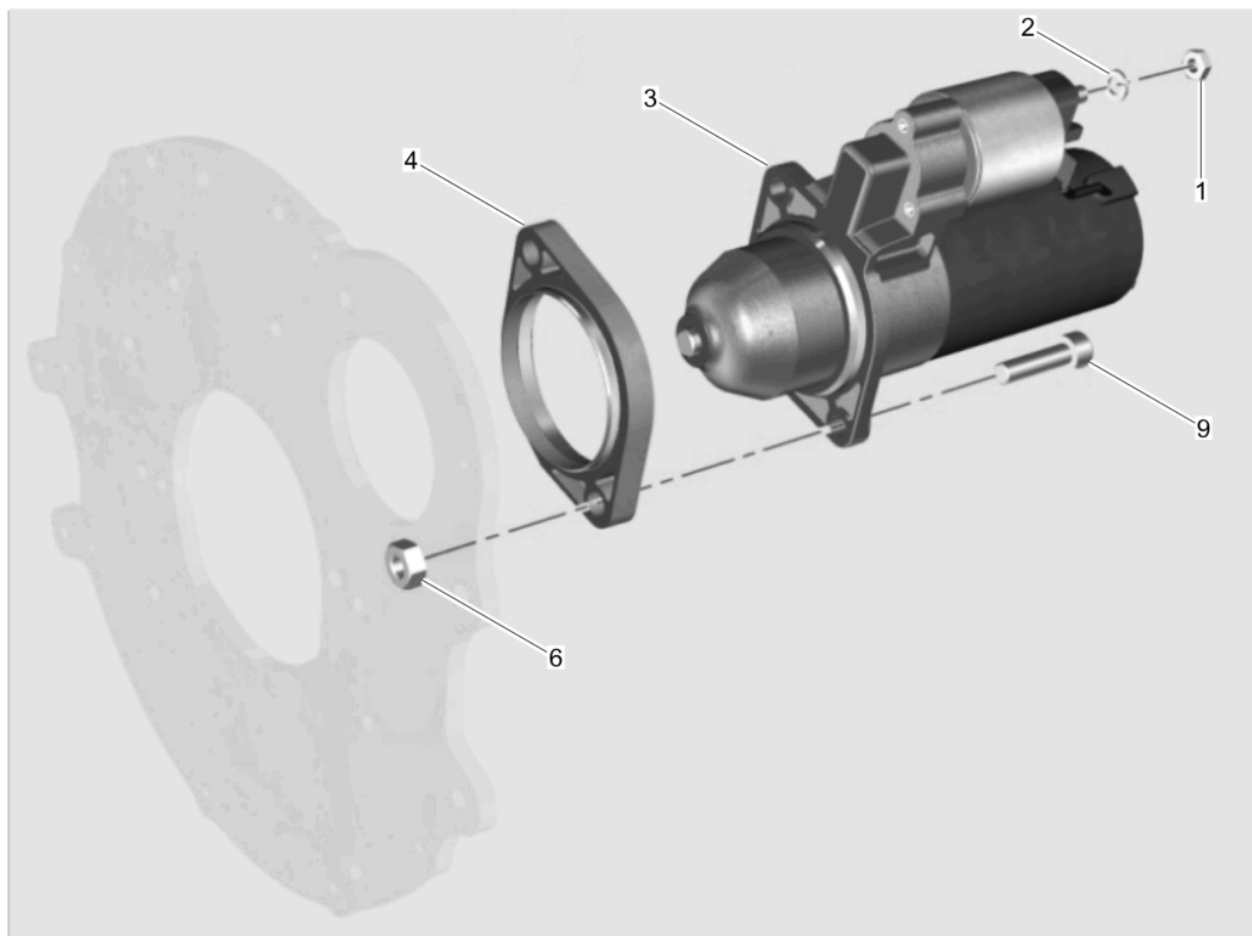

Pos. Item	Artikel Nr. Item no.	Pc.	Unit	Beschreibung Descripción	Description Description	Abm. Dim.	Norm Standard
						Drehmoment Torque	Schmierstoff Lubricant
1	5000215493	1	pc	Sechskantmutter Tuerca hexagonal	Hexagon nut Écrou hexagonal		
2	5000082288	1	pc	Scheibe Arandela	Washer Rondelle		
3	5000211380	1	pc	Anlasser Arrancador	Starter Démarreur		
4	5000206968	1	pc	Flansch Brida	Flange Bride		
6	5000083011	2	pc	Mutter Tuerca	Nut Écrou		
9	5000083027	2	pc	Schraube Tornillo	Screw Vis		

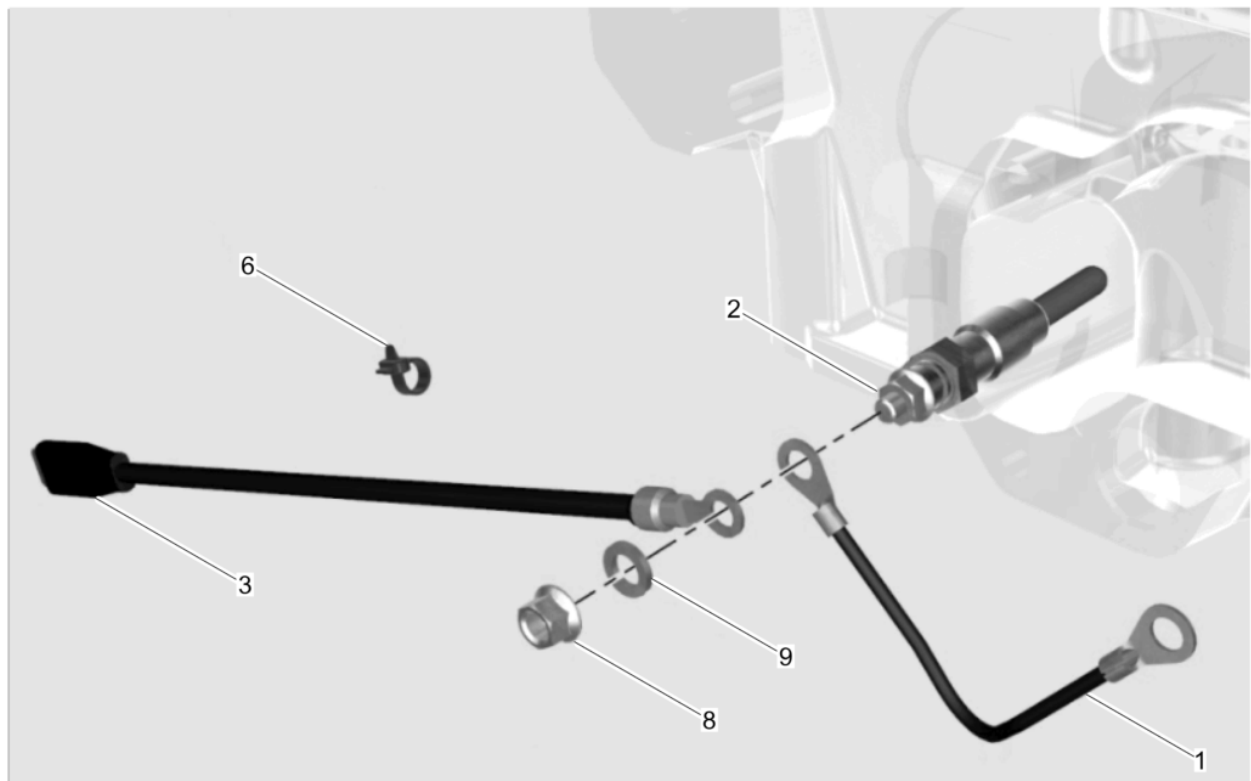

Pos. Item	Artikel Nr. Item no.	Pc.	Unit	Beschreibung Descripción	Description Description	Abm. Dim.	Norm Standard
						Drehmoment Torque	Schmierstoff Lubricant
1	5000159259	1	pc	Kabel Cable	Cable Câble		
2	5100042312	2	pc	Glühkerze 12V Tapón luminoso 12v	Glow plug 12v Bougie de préchauffage 12v		
3	5100026470	1	pc	Kabel, Glühkerze Cable, tapón luminoso	Wire, glow plug Cable, bougie de préchauffage		
6	5000209062	1	pc	Kabelbinder Fijación	Tie cable Attache		
8	5100049823	2	pc	Mutter Tuerca	Nut Écrou		
9	5000209066	2	pc	Scheibe Arandela	Washer Rondelle	4,3	

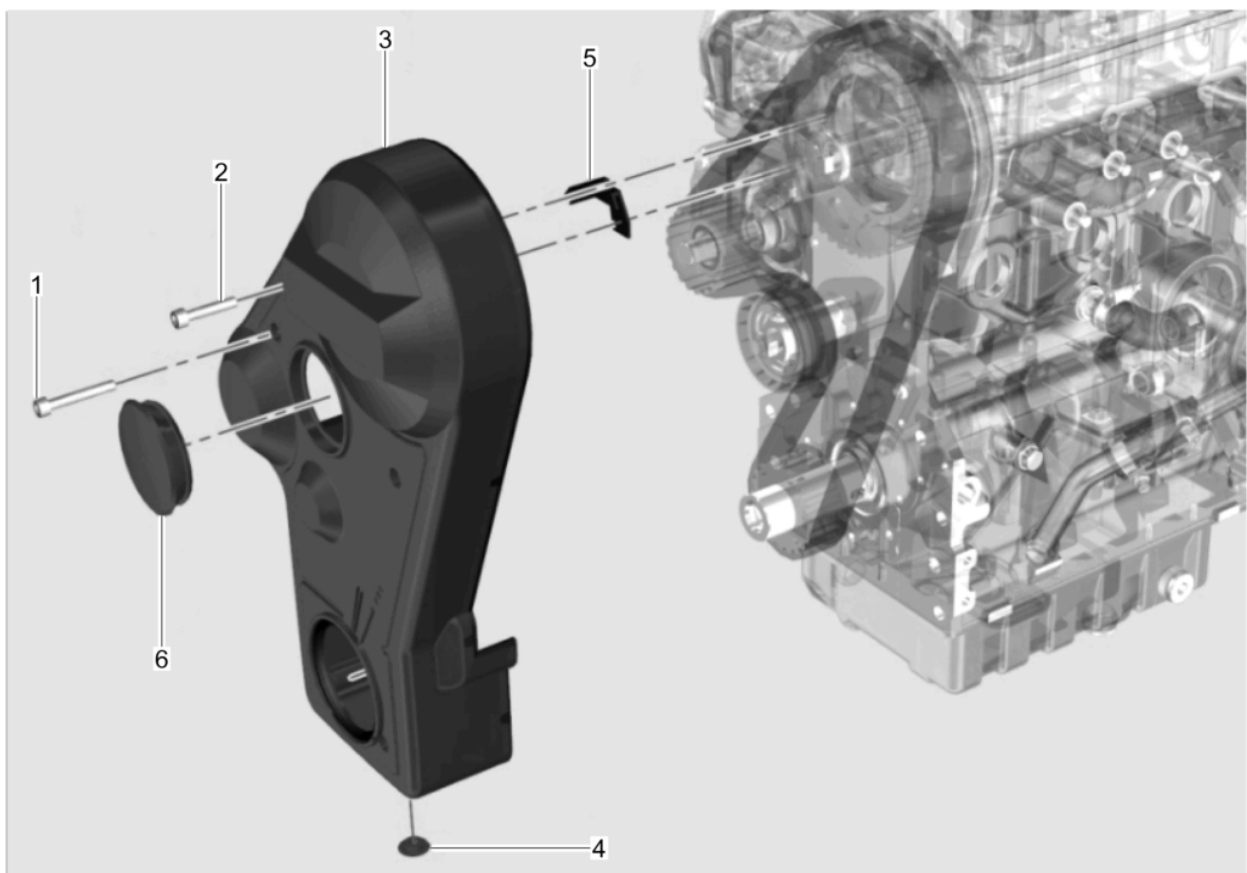

Pos. Item	Artikel Nr. Item no.	Pc.	Unit	Beschreibung Descripción	Description Description	Abm. Dim.	Norm Standard
						Drehmoment Torque	Schmierstoff Lubricant
1	5000159564	1	pc	Schraube Tornillo	Screw Vis		
2	5000159475	4	pc	Schraube Tornillo	Screw Vis		
3	5100026420	1	pc	Keilriemenschutz Protección de la polea	Belt guard Protection de courroie		
4	5000159268	1	pc	Stopfen Enchufe	Plug Prise		
5	5000215499	1	pc	Dichtung Junta de estanqueidad	Gasket Garniture		
6	5100026421	1	pc	Schutzdeckel Tapa de protección	Protective cover Couvercle de protection		



**WACKER
NEUSON**

