



**WACKER  
NEUSON**

Ersatzteilkatalog  
Spare parts catalog  
Catálogo de piezas de repuesto  
Catalogue de pièces de rechange

Vibrationsstampfer  
Vibratory rammer  
Apsonadores vibratorios  
Pilonneuse vibrante

**BS50-4AS 11IN  
US**



Type	BS50-4AS 11IN US
Material Number	5100030598
Version	100
Language	de   en   es   fr



[www.wackerneuson.com](http://www.wackerneuson.com)

Copyright © 07.2023  
Wacker Neuson Produktion GmbH & Co. KG  
Printed in Germany.  
All rights reserved.

Ein Typenschild mit Typ, Artikelnummer, Version und Maschinen-Nummer ist an jedem Gerät angebracht. Die Daten von diesem Schild bitte notieren, damit sie auch bei Verlust oder Beschädigung des Schildes noch vorhanden sind. Der Typ, die Artikelnummer, die Versions-Nummer und die Maschinen-Nummer sind bei der Ersatzteilbestellung oder Nachfragen bezüglich Service-Informationen stets erforderlich.

Bei den in den Ersatzteillisten fettgedruckten Nummern handelt es sich um empfohlene Ersatzteile. Dies bedeutet, daß diese Teile bei normalen Anwendungsbedingungen natürlicher Abnutzung ausgesetzt sind und gelegentlich ersetzt oder überarbeitet werden müssen. Es wird geraten, diese Teile auf Lager bereit zu haben, um für Service-Arbeiten an diesem Gerät vorbereitet zu sein. Lagerbestände für diese und andere Teile, welche für ausgiebigere Reparaturarbeiten benötigt werden, können je nach Service-Gewohnheiten der einzelnen Kunden variieren.

Die Nummern meines Gerätes sind:

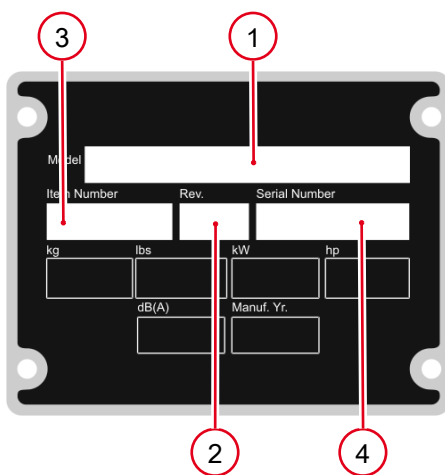

- 1. Typ
- 2. Version
- 3. Artikel-Nr.
- 4. Maschinen-Nr.

**Umrechnungstabelle**

Volumeneinheit	
1 ml	0.034 US fl.oz.
1 l	0.260 gal
Längeneinheit	
1 mm	0.039 in
1 m	3.280 ft
Gewicht	
1 kg	2.200 lbs
1 g	0.035 oz
Geschwindigkeit	
1 km/h	0.620 mph
Drehmoment	
1 Nm	0.740 ft.lbs

A nameplate listing the Model Number, Item Number, Revision, and Serial Number is attached to each unit. Please record the information found on this plate so it will be available should the nameplate become lost or damaged. When ordering parts or requesting service information, you will always be asked to specify the model, item number, revision number, and serial number of the unit.

Part Numbers appearing in boldface type are recommended spare parts. This means that these parts are subject to wear under normal operating conditions and may require periodic service or replacement. It is recommended that these items be stocked to meet the expected service requirements of this model. Actual stocking quantities of these and other parts used in more extensive repairs will depend on the service practices of each customer.

My machine's numbers are:



1. Model
2. Revision
3. Item No.
4. Serial No.

**Conversion table**

Volume unit	
1 ml	0.034 US fl.oz.
1 l	0.260 gal
Unit of length	
1 mm	0.039 in
1 m	3.280 ft
Weight	
1 kg	2.200 lbs
1 g	0.035 oz
Speed	
1 km/h	0.620 mph
Torque	
1 Nm	0.740 ft.lbs

Una placa de identificación con el modelo, número de referencia, nivel de revisión y número de serie ha sido añadida en cada máquina. Favor de anotar los datos en la placa en caso de que la placa de identificación sea destruida o perdida. En todos los pedidos para repuestos necesita siempre el modelo, el número de referencia, el nivel de revisión y el número de serie de la máquina en cuestión.

Los números de partes en negritas en las Listas Ilustradas de Partes son los repuestos recomendados, esto quiere decir que estas partes se desgastarán bajo circunstancias de funcionamiento normales y pueden requerir servicio periódico o su reemplazo. Se recomienda que el cliente mantenga un abastecimiento adecuado de estas partes para poder satisfacer la demanda requerida por el servicio a la máquina. La cantidad de repuestos que el cliente necesitará para reparaciones dependerá de la póliza de servicio de cada cliente.

Los números de mi máquina son:

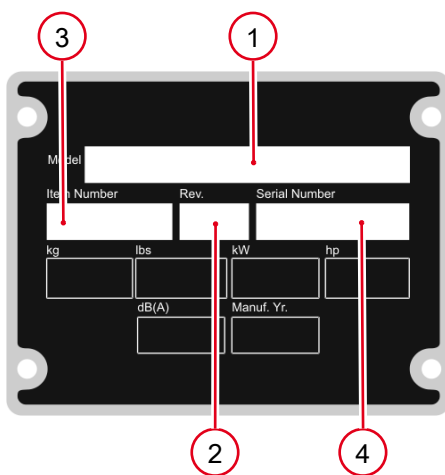

1. Modelo
2. Nivel de revisión
3. Número de referencia
4. Número de Serie

**Tabla de conversión**

Unidad de volumen	
1 ml	0.034 US fl.oz.
1 l	0.260 gal
Unidad de longitud	
1 mm	0.039 in
1 m	3.280 ft
Peso	
1 kg	2.200 lbs
1 g	0.035 oz
Velocidad	
1 km/h	0.620 mph
Par de apriete	
1 Nm	0.740 ft.lbs

Une plaque signalétique mentionnant le modèle, le numéro de référence, le niveau de revision et le numéro de série est fixée sur chaque machine. Veuillez noter les informations relevées sur cette plaque de façon à ce qu'elles soient toujours disponibles si la plaque signalétique venait à être perdue ou endommagée. Lorsque vous commandez des pièces détachées ou vous sollicitez des informations après-vente, on vous demandera toujours de préciser le modèle, le numéro de référence, le niveau de revision et le numéro de série de la machine.

Les numéros de pièces imprimés en caractères gras dans les Listes des Pièces Détachées de ce manuel sont les pièces détachées recommandées par la Wacker. Cela veut dire que ces pièces sont sujettes à usure dans des conditions de travail normales et peuvent nécessiter de l'entretien ou leur remplacement. Nous recommandons que vous disposez d'un stock de ces pièces pour pouvoir satisfaire la demande d'entretien de cette machine. Le client doit décider lui-même de la quantité exacte de pièces de rechange qu'il disposera dans ses stocks.

Les numéros de ma machine son :



- 1. Typ
- 2. Version
- 3. Artikel-Nr.
- 4. Maschinen-Nr.

**Table de conversion**

Unité de volume	
1 ml	0.034 US fl.oz.
1 l	0.260 gal
Unité de longueur	
1 mm	0.039 in
1 m	3.280 ft
Poids	
1 kg	2.200 lbs
1 g	0.035 oz
Vitesse	
1 km/h	0.620 mph
Couple de serrage	
1 Nm	0.740 ft.lbs

Stampfer Rammer Aplonador Pilonneuse .....	10
---	----

Führungsbügel Kpl. Guiding frame cpl. Manillar cpl. Étrier cpl. ....	12
---	----

Gasregler Kpl. Throttle control cpl. Acelerador cpl. Commande des gaz cpl. ....	14
--	----

Führungszylinder Kpl. Guiding cylinder cpl. Cilindro de guía cpl. Cylindre de guidage cpl. ....	16
--	----

Kurbeltrieb Kpl. Crank gear cpl. Mecanismo de manivela cpl. Arbre manivelle cpl. ....	18
--	----

Fliehkraftglocke Kpl. Clutch drum cpl. Campana centrífuga cpl. Canter embrayage cpl. ....	20
--	----

Motor Anbauteile Mounting parts engine Pie de fijación motor Pièces d'adaption moteur .....	22
--	----

Luftfilter Kpl. Air filter cpl. Filtro de aire cpl. Filtre à air cpl. ....	24
---	----

Stampfeinsatz Kpl. Ramming shoe cpl. Pisón cpl. Tête de frappe cpl. ....	26
---	----

Aufkleber Labels Calcomanías Autocollants .....	28
--	----

Wartungspaket Maintenance kit Juego para mantenimiento Jeu d'entretien .....	30
---	----

Motor  
Engine  
Motor  
Moteur



Reversierstarter Recoil starter Starter reversible Démarreur réversible .....	32
--	----

Gebläseabdeckung Fan hood Tapa de ventilador Couvercle du sys. de vent. ....	34
---	----

Vergaser Carburetor Carburador Carburateur .....	36
---	----

Schalldämpfer Muffler Silenciador Silencieux .....	40
---	----

Schwungrad Fly wheel Volante Volant .....	42
--	----

Regler Governor Regulador Régulateur .....	44
---	----

Zylinderkopf Cylinder head Culata Culasse .....	46
--	----

Kurbelgehäuseabdeckung Crankcase cover Cubierta da la caja de manivel Couvercle carter de manivelle .....	48
--	----

Kolben-Kurbelwelle Piston-crankshaft Pistón-cigüeñal Piston-vilebrequin .....	50
--	----

Nockenwelle Camshaft Arbol de levas Arbre à cames .....	52
--	----

Ölstand-Warnsystem Oil alert Alerta de aceite Avertissement d'huile .....	54
--	----

Aufkleber Labels Calcomanias Autocollants .....	56
--	----



Werkzeug  
Tool  
Herramienta  
Outil ..... 58



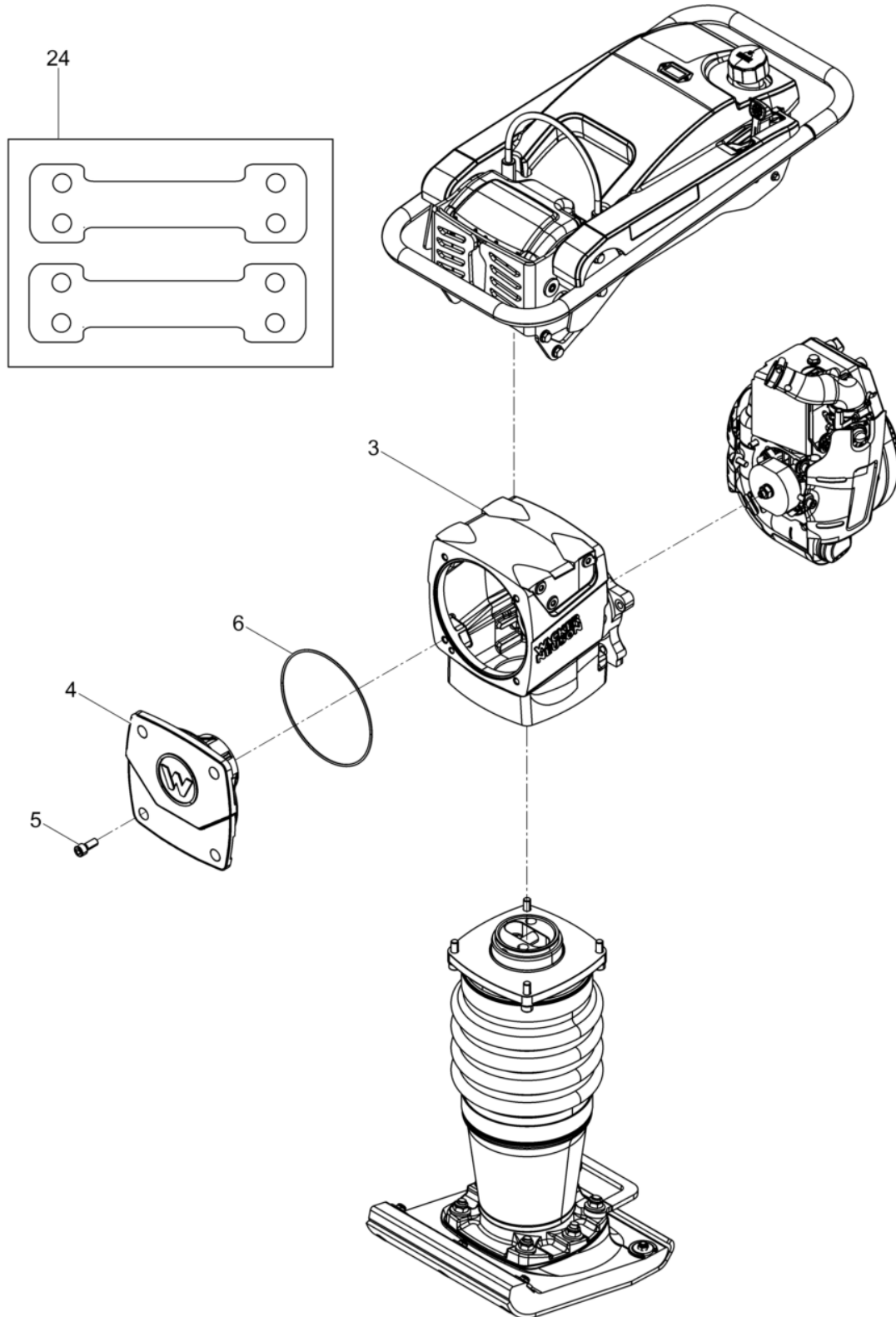

Pos. Item	Artikel Nr. Item no.	Pc.	Unit	Beschreibung Descripción	Description Description	Abm. Dim.	Norm Standard
						Drehmoment Torque	Schmierstoff Lubricant
3	5200014878	1	pc	Kurbelgehäuse Cárter	Crankcase Carter		
4	5100032132	1	pc	Kurbelgehäusedeckel Tapa del cárter	Crankcase cover Couvercle de carter		
5	5000011535	4	pc	Zylinderschraube Tornillo cilíndrico	Cheese head screw Vis à tête cylindrique		
6	5100033181	1	pc	O-Ring Anillo-o	O-ring Bague-o		
7	5000117567	1	pc	Stift Pasador	Pin Goupille	M8 x 20	ISO8734
24	5100032274	1	pc	Ersatz-Transportrolle Juego-rodillo de transporte	Roller kit Jeu de rouleau de transport		

Führungsbügel Kpl.  
Guiding frame cpl.  
Manillar cpl.  
Étrier cpl.

BS50-4AS 11IN US

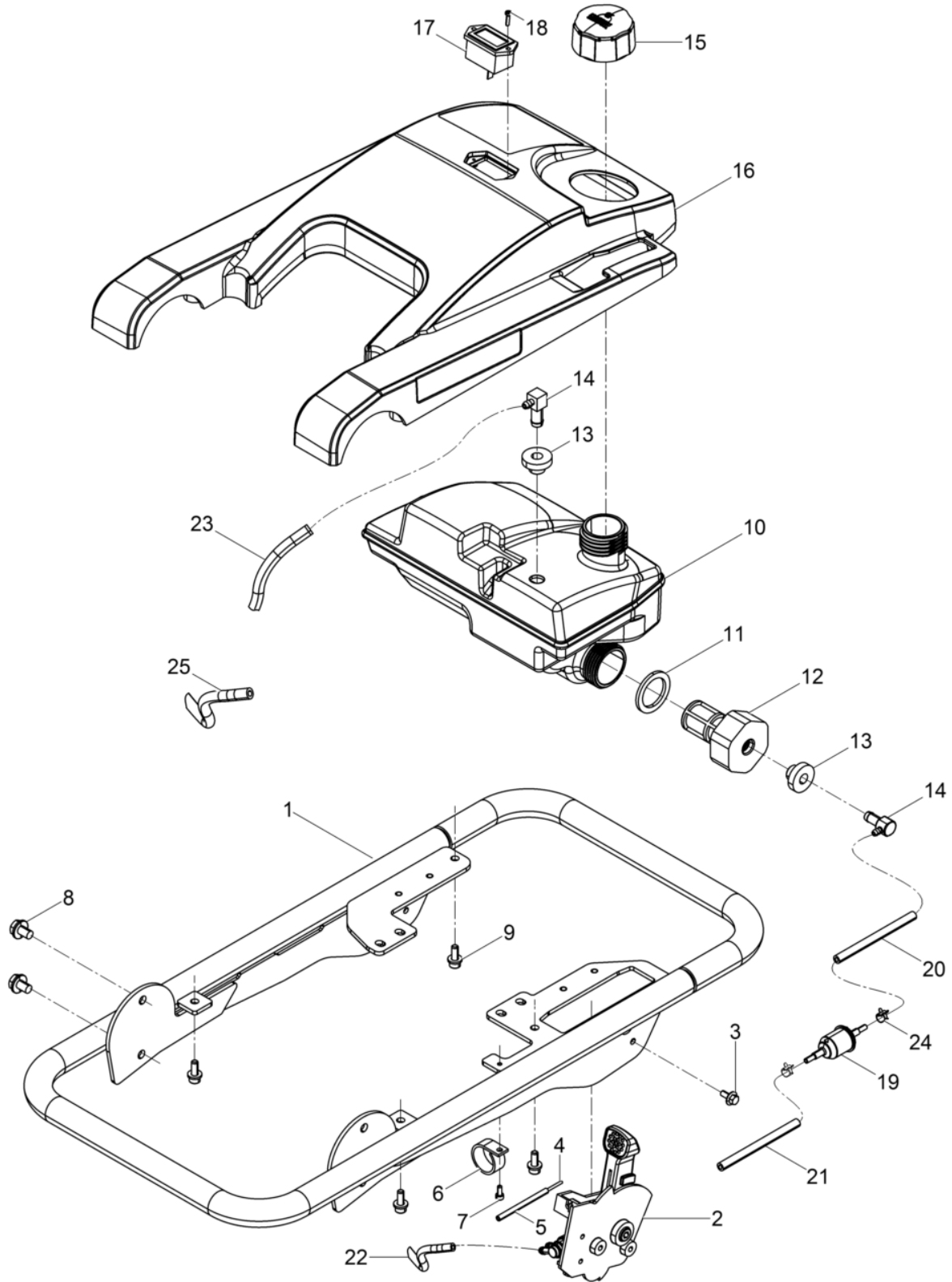

Pos. Item	Artikel Nr. Item no.	Pc.	Unit	Beschreibung Descripción	Description Description	Abm. Dim.	Norm Standard
						Drehmoment Torque	Schmierstoff Lubricant
1	5100028600	1	pc	Führungsbügel Manija	Guide handle Poignée		
2	5100030466	1	pc	Gasregler Kpl. Acelerador cpl.	Throttle control cpl. Commande des gaz cpl.		
3	5000155845	2	pc	Sechskantschraube Tornillo hexagonal	Hexagonal head cap screw Boulon à tête hexagonale	M5 x 12	
4	5100032227	1	pc	Bowdenzugseil Cable bowden	Bowden cable Câble bowden		
5	5100032273	1	pc	Bowdenzughülle Cable bowden exterior	Outer bowden cable Câble bowden extérieur		
6	5000155562	1	pc	Befestigung Clip	Clip Clip		
7	5100035983	1	pc	Blindniet Remache ciego	Blind rivet Rivet dobturation		
8	5100027071	4	pc	Schraube Tornillo	Screw Vis		
9	5000160861	8	pc	Schraube Tornillo	Screw Vis	M6 x 16	
10	5100030302	1	pc	Kraftstofftank Tanque de combustible	Fuel tank Réservoir de carburant		
11	5000086312	1	pc	Dichtungsring Anillo sellador	Ring seal Rondelle à étancher		
12	5100028935	1	pc	Wasserfilter Filtro de agua	Water filter Filtre à eau		
13	5000053577	2	pc	Tankbuchse Buje	Tank valve bushing Douille		
14	5100032118	2	pc	Anschlussnippel Boquilla de conexión	Connecting nipple Raccord fileté		
15	5100030407	1	pc	Kraftstofftankdeckel Tapa de tanque	Tank cap Couvercle du réservoir		
16	5100031422	1	pc	Abdeckung Cubierta	Covering Couverture		
17	5100034578	1	pc	Betriebsstundenzähler Contador de las horas	Working hour meter Compteur d'heures		
18	5100006109	2	pc	Schraube Tornillo	Screw Vis	M3x12-CE-TX10	
19	5100022620	1	pc	Kraftstofffilter Filtro de combustible	Fuel filter Filtre à carburant		
20	5100037400	1	pc	Kraftstoffschlauch Manguera de combustible	Fuel hose Tuyau à essence		
21	5100019507	1	pc	Kraftstoffleitung & Filter Manguera de combustible & filtro	Fuel hose w/filter Tuyau à essence & filtre		
22	5100037403	1	pc	Kraftstoffschlauch Manguera de combustible	Fuel hose Tuyau à essence		
23	5100037404	1	pc	Kraftstoffschlauch Manguera de combustible	Fuel hose Tuyau à essence		
24	5000171698	2	pc	Schelle Abrazadera	Clamp Agrafe	3/8in	
25	5100034659	1	pc	Luftschlauch Manguera de aire	Air hose Boyau d'air		

Gasregler Kpl.  
Throttle control cpl.  
Acelerador cpl.  
Commande des gaz cpl.

BS50-4AS 11IN US

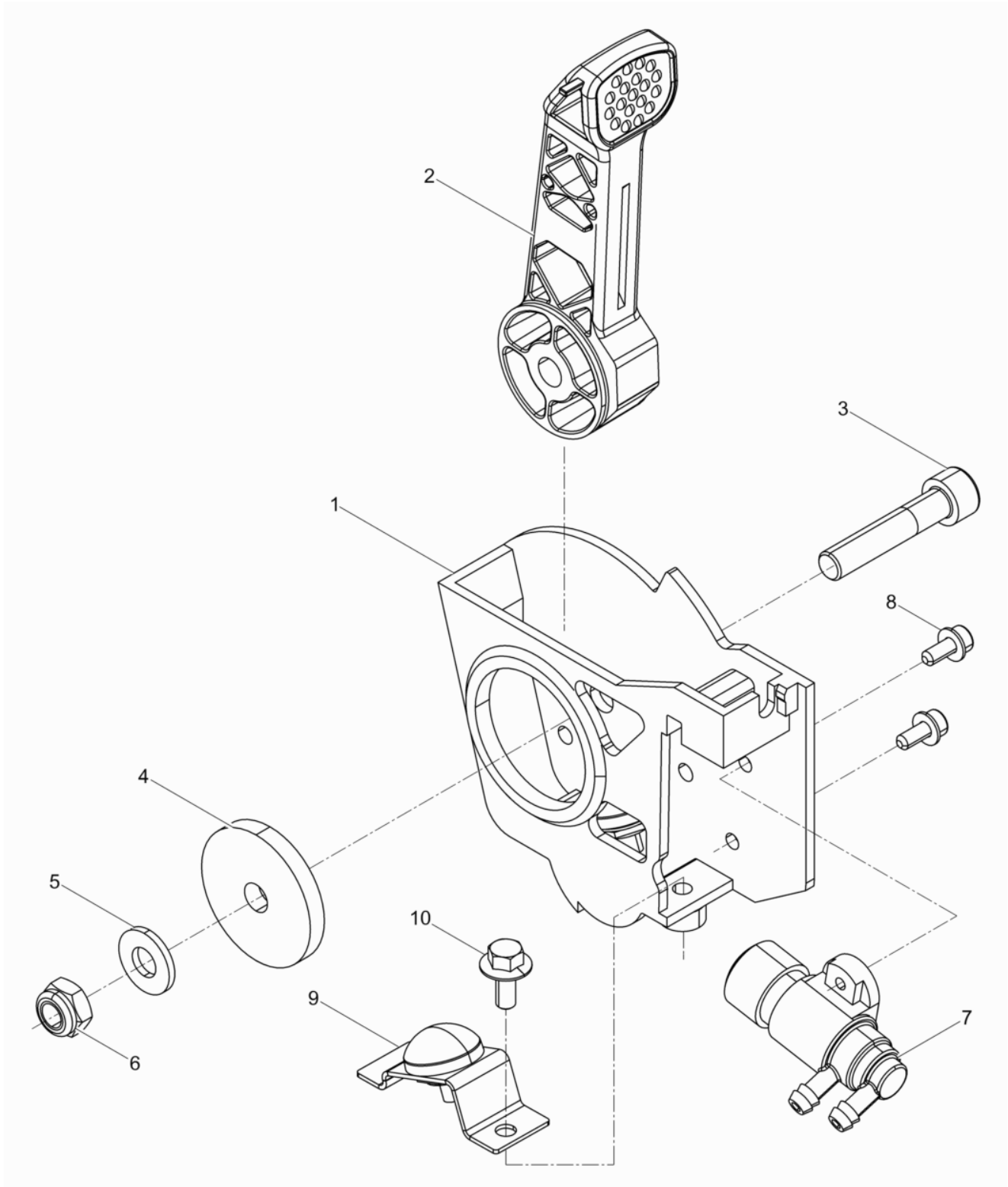

Pos. Item	Artikel Nr. Item no.	Pc.	Unit	Beschreibung Descripción	Description Description	Abm. Dim.	Norm Standard
						Drehmoment Torque	Schmierstoff Lubricant
1	5100032228	1	pc	Gasreglerkonsole Soporte	Bracket Support		
2	5100032229	1	pc	Gashebel Acelerador	Throttle lever Manette de gaz		
3	5000011539	1	pc	Zylinderschraube Tornillo cilíndrico	Cheese head screw Vis à tête cylindrique	M8 x 40 25Nm/18ft.lbs	ISO4762
4	5000105194	1	pc	Scheibe Arandela	Washer Rondelle	M8 x 1,5in	
5	5000033198	1	pc	Spannscheibe Arandela elástica	Lockwasher Rondelle de ressort		DIN6796
6	5000010367	1	pc	Sechskantmutter Tuerca hexagonal	Hexagon nut Écrou hexagonal		DIN985
7	5100032270	1	pc	Kraftstoffhahn Llave de combustible	Fuel cock Robinet d'essence		
8	5000165047	2	pc	Zylinderschraube Tornillo cilíndrico	Socket head cap screw Vis à tête cylindrique	M4 x 10	
9	5100032272	1	pc	Kurzschlusschalter Kpl. Obturador de guillotina cpl.	Sliding shutter cpl. Obturateur à guillotine cpl.		
10	5000155845	1	pc	Sechskantschraube Tornillo hexagonal	Hexagonal head cap screw Boulon à tête hexagonale	M5 x 12	

Führungszylinder Kpl.  
Guiding cylinder cpl.  
Cilindro de guía cpl.  
Cylindre de guidage cpl.

BS50-4AS 11IN US

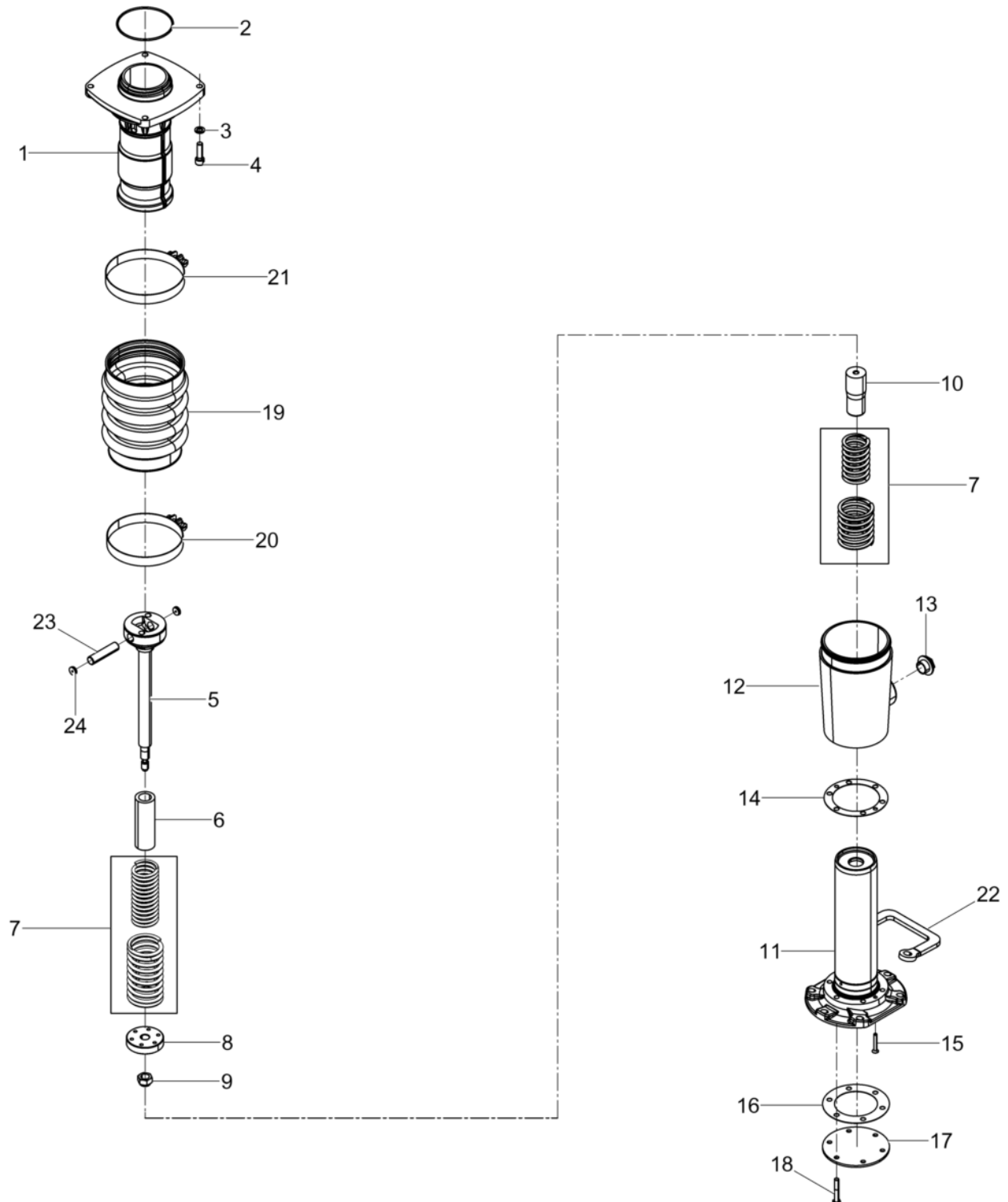



Pos. Item	Artikel Nr. Item no.	Pc.	Unit	Beschreibung Descripción	Description Description	Abm. Dim.	Norm Standard
						Drehmoment Torque	Schmierstoff Lubricant
1	5100038429	1	pc	Führungszylinder Cilindro de guía	Guide cylinder Cylindre de guidage		
2	5000031880	1	pc	O-Ring Anillo-o	O-ring Joint torique	96 x 3	
3	5000010644	4	pc	Federring Arandela elástica	Lock washer Rondelle de ressort	A10	DIN128
4	5000011533	4	pc	Zylinderschraube Tornillo cilíndrico	Cheese head screw Vis à tête cylindrique	M10 x 35 49Nm/36ft.lbs	ISO4762
5	5100038472	1	pc	Führungskolben Émbolo guía	Guide piston Piston de guidage		
6	5100032036	1	pc	Dämpfungbüchse Buje	Bushing Douille		
7	5100032037	2	pc	Federsatz Juego de resorte	Spring set Jeu de ressort		
8	5100032038	1	pc	Kolbenführung Guía de pistón	Piston guide Guide de piston		
9	5000110196	1	pc	Sicherungsmutter Contratuerca	Lock nut Contre-écrou	M16 x 1,5	
10	5100032039	1	pc	Dämpfungsstopfen Tapón amortiguador	Damper Bouchon amortisseur		
11	5000113813	1	pc	Federzylinder Cilindro de resorte	Spring cylinder Cylindre de ressort		
12	5100039951	1	pc	Schutzrohr Tubo de protección	Protective pipe Tube de protection		
13	5100033182	1	pc	Ölstandsauge Indicador de aceite	Sight glass Indicateur		
14	5100032110	1	pc	Dichtung Junta	Gasket Joint		
15	5000155017	2	pc	Senkschraube Tornillo avellanado	Countersunk screw Vis à tête conique	M6 x 40	ISO10642
16	5100032111	1	pc	Federzylinderdichtung Junta	Gasket Joint		
17	5100031608	1	pc	Deckel Tapa	Cover Couvercle		
18	5000011343	6	pc	Sechskantschraube Tornillo hexagonal	Hexagonal head cap screw Vis à tête hexagonale	M8 x 50 25Nm/18ft.lbs	DIN931
19	5100032112	1	pc	Faltenbalg Fuelle acordeón	Bellows Soufflet		
20	5000110537	1	pc	Schelle Abrazadera	Clamp Agrafe	5,75in ID	
21	5000110528	1	pc	Schelle Abrazadera	Clamp Agrafe	5,25in ID	
22	5100031620	1	pc	Tragegriff Mango	Handle Poignée		
23	5100032026	1	pc	Kolbenbolzen Pasador de pistón	Piston pin Axe de piston		
24	5100032113	2	pc	Kolbensicherung Tapón	Plug Bouchon		

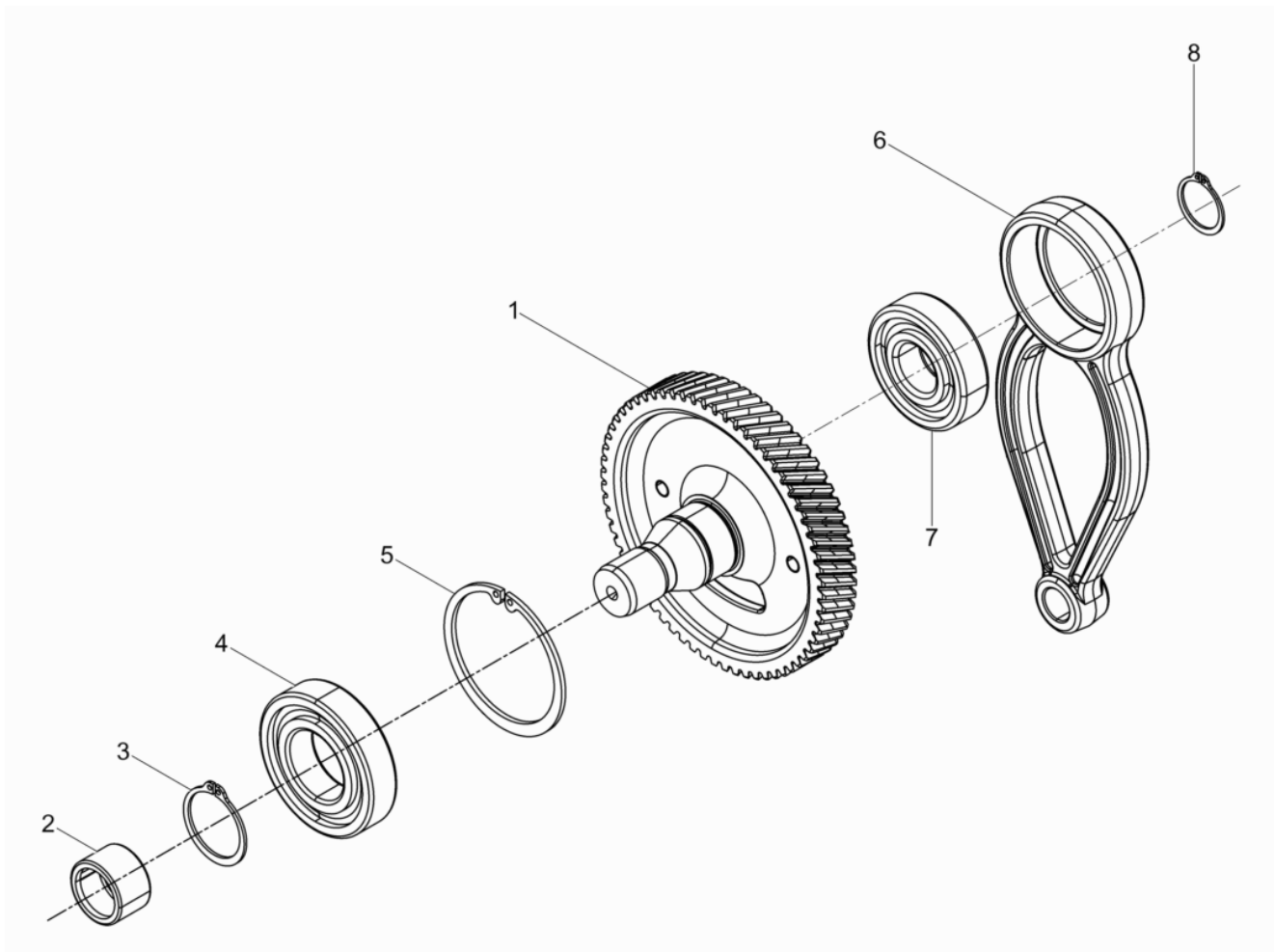

Pos. Item	Artikel Nr. Item no.	Pc.	Unit	Beschreibung Descripción	Description Description	Abm. Dim.	Norm Standard
						Drehmoment Torque	Schmierstoff Lubricant
1	5100037296	1	pc	Kurbeltrieb Mecanismo de manivelle	Crank gear Arbre manivelle		
2	5000072061	1	pc	Nadellager Rodamiento de agujas	Needle bearing Roulement à aiguilles		
3	5002003022	1	pc	Sicherungsring Anillo de retención	Retaining ring Bague d'arrêt	35 x 1,5	DIN471
4	5002003021	1	pc	Rillenkugellager Rodamiento de bolas	Grooved ball bearing Roulement à billes		
5	5002003023	1	pc	Sicherungsring Anillo de retención	Retaining ring Bague d'arrêt	72 x 2,5	DIN472
6	5100037875	1	pc	Pleuel Biela	Connecting rod Bielle		
7	5000045190	1	pc	Rillenkugellager Rodamiento de bolas	Grooved ball bearing Roulement à billes		
8	5002001041	1	pc	Sicherungsring Anillo de retención	Retaining ring Bague d'arrêt	25 x 1,2	DIN471

Fliehkraftglocke Kpl.  
Clutch drum cpl.  
Campana centrifuga cpl.  
Canter embrayage cpl.

BS50-4AS 11IN US

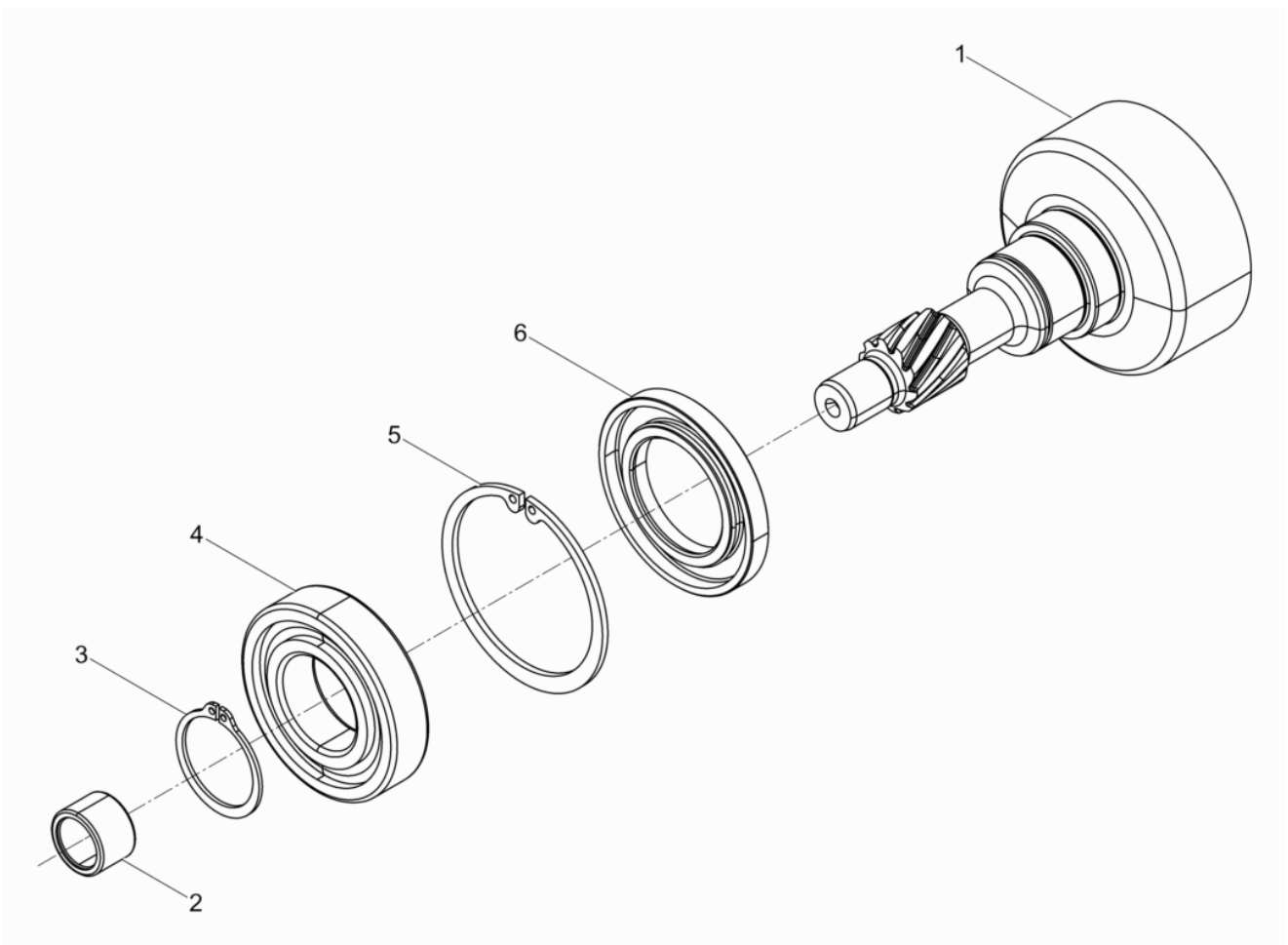

Pos. Item	Artikel Nr. Item no.	Pc.	Unit	Beschreibung Descripción	Description Description	Abm. Dim.	Norm Standard
						Drehmoment Torque	Schmierstoff Lubricant
1	5100038030	1	pc	Fliehkraftglocke Campana centrifuga	Clutch drum Canter embrayage		
2	5000039020	1	pc	Nadelhülse Rodamiento de agujas	Needle bearing Roulement à aiguilles		
3	5002003022	1	pc	Sicherungsring Anillo de retención	Retaining ring Bague d'arrêt	35 x 1,5	DIN471
4	5002003021	1	pc	Rillenkugellager Rodamiento de bolas	Grooved ball bearing Roulement à billes		
5	5002003023	1	pc	Sicherungsring Anillo de retención	Retaining ring Bague d'arrêt	72 x 2,5	DIN472
6	5000039050	1	pc	Wellendichtring Sello del eje	Shaft seal Bague d'étanchéité		

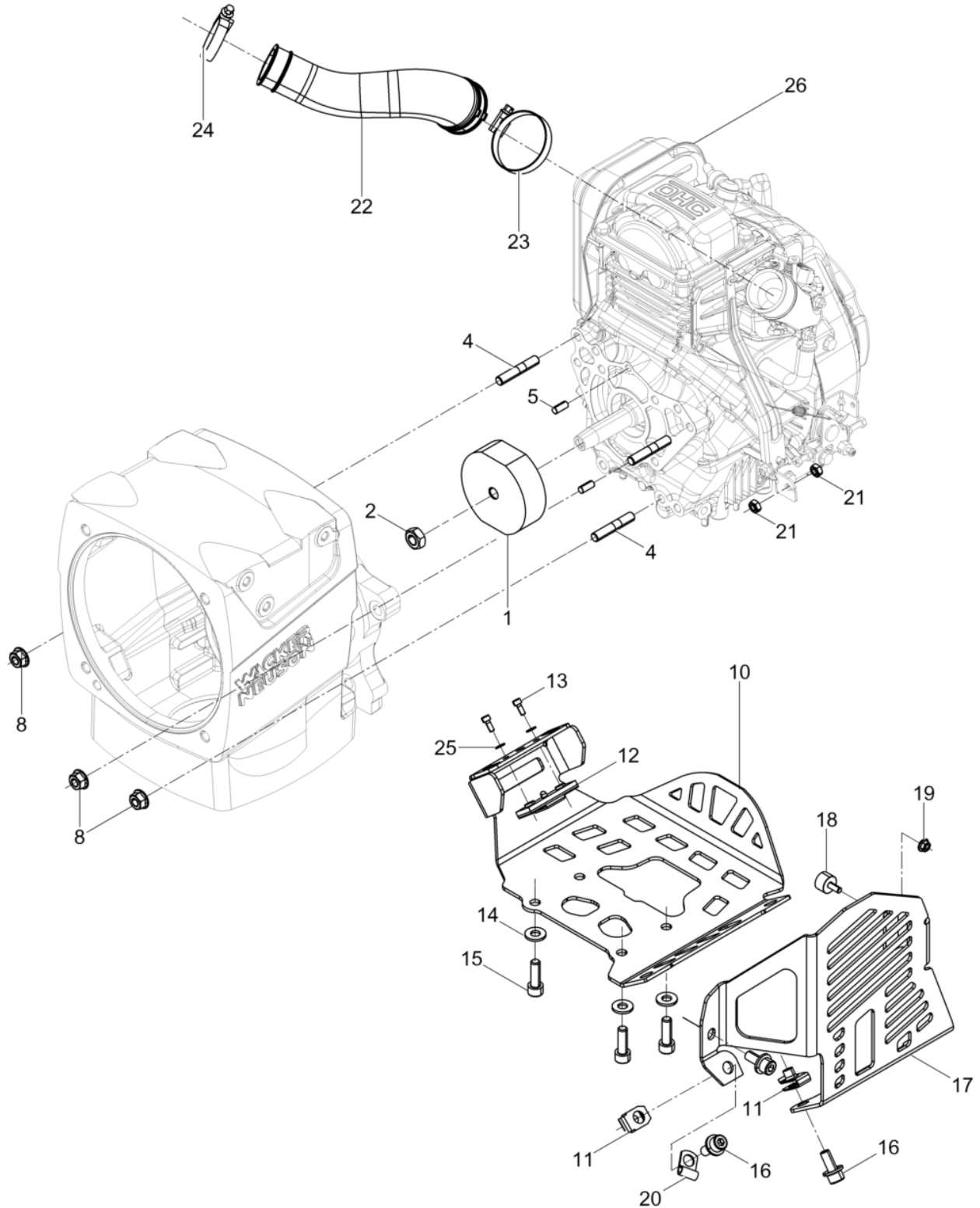

Pos. Item	Artikel Nr. Item no.	Pc.	Unit	Beschreibung Descripción	Description Description	Abm. Dim.	Norm Standard
						Drehmoment Torque	Schmierstoff Lubricant
1	5100032207	1	pc	Fliehkraftkupplung Embrague centrifugo	Centrifugal clutch Embrayage centrifuge		
2	5000010883	1	pc	Sechskantmutter Tuerca hexagonal	Hexagon nut Écrou hexagonal	25Nm/18ft.lbs	
3	5000010621	1	pc	Scheibe Arandela	Flat washer Rondelle		
4	5000010928	4	pc	Stiftschraube Tornillo espárrago	Stud bolt Goupille fileté	M8 x 30 25Nm/18ft.lbs	DIN835
5	5100037204	2	pc	Zylinderstift Pasador cilindrico	Straight pin Goupille cylindrique		
6	5000010622	2	pc	Scheibe Arandela	Flat washer Rondelle		
7	5100034621	1	pc	Luftleitblech Kpl. Chapa deflectora cpl.	Air duct plate cpl. Tôle d'aeration cpl.		
8	5000096677	4	pc	Sechskantmutter Tuerca hexagonal	Hexagon nut Écrou hexagonal	M8	DIN6923
9	5100017182	1	pc	Sechskantflanschschaube Tornillo hexagonal de brida	Hexagonal flange head screw Vis hexagonale de bride	M6 x 35	
10	5100040104	1	pc	Motorschutz Unten Protección del motor abajo	Motor protection bottom Protection moteur en bas		
11	5100033184	3	pc	Sicherungsmutter Contratuerca	Locknut Contre-écrou		
12	5100032208	1	pc	Niedriger Öldruck Anzeige Cuadro indicador de baja presión del aceite	Low oil pressure display Indicateur de pression		
13	5000165047	2	pc	Zylinderschraube Tornillo cilindrico	Socket head cap screw Vis à tête cylindrique	M4 x 10	
14	5100040847	6	pc	Kontaktscheibe Arandela	Washer Rondelle		
15	5000151559	6	pc	Zylinderschraube Tornillo cilindrico	Cheese head screw Vis à tête cylindrique	M8 x 25 27Nm/20ft.lbs	ISO4762
16	5000177452	4	pc	Schraube Tornillo	Screw Vis		
17	5100040107	1	pc	Motorschutz Oben Protección del motor encima	Motor protection top Protection moteur haut	3Nm/2ft.lbs	
18	5100032209	1	pc	Stoßfänger Paragolpe	Bumper Pare-chocs		
19	5000183750	1	pc	Sechskantmutter Tuerca hexagonal	Hexagon nut Écrou hexagonal	27Nm/20ft.lbs	
20	5000156954	1	pc	Schlauchschele Abrazaderas de manguera	Hose clamp Agrafe de tuyau	1/4in	
21	5000010880	2	pc	Sechskantmutter Tuerca hexagonal	Hexagon nut Écrou hexagonal		
22	5100032250	1	pc	Luftrohr Tubo de aire	Air pipe Tuyau d'air		
23	5000078844	1	pc	Schelle Abrazadera	Clamp Agrafe	32-50	
24	5100033186	1	pc	Schelle Abrazadera	Clamp Agrafe		
25	5100004421	2	pc	Kontaktscheibe Arandela	Contact disk Rondelle	4	
26	5100032206	1	pc	Benzinmotor Motor a gasolina	Gas engine Moteur à essence		

Luftfilter Kpl.  
Air filter cpl.  
Filtro de aire cpl.  
Filtre à air cpl.

BS50-4AS 11IN US

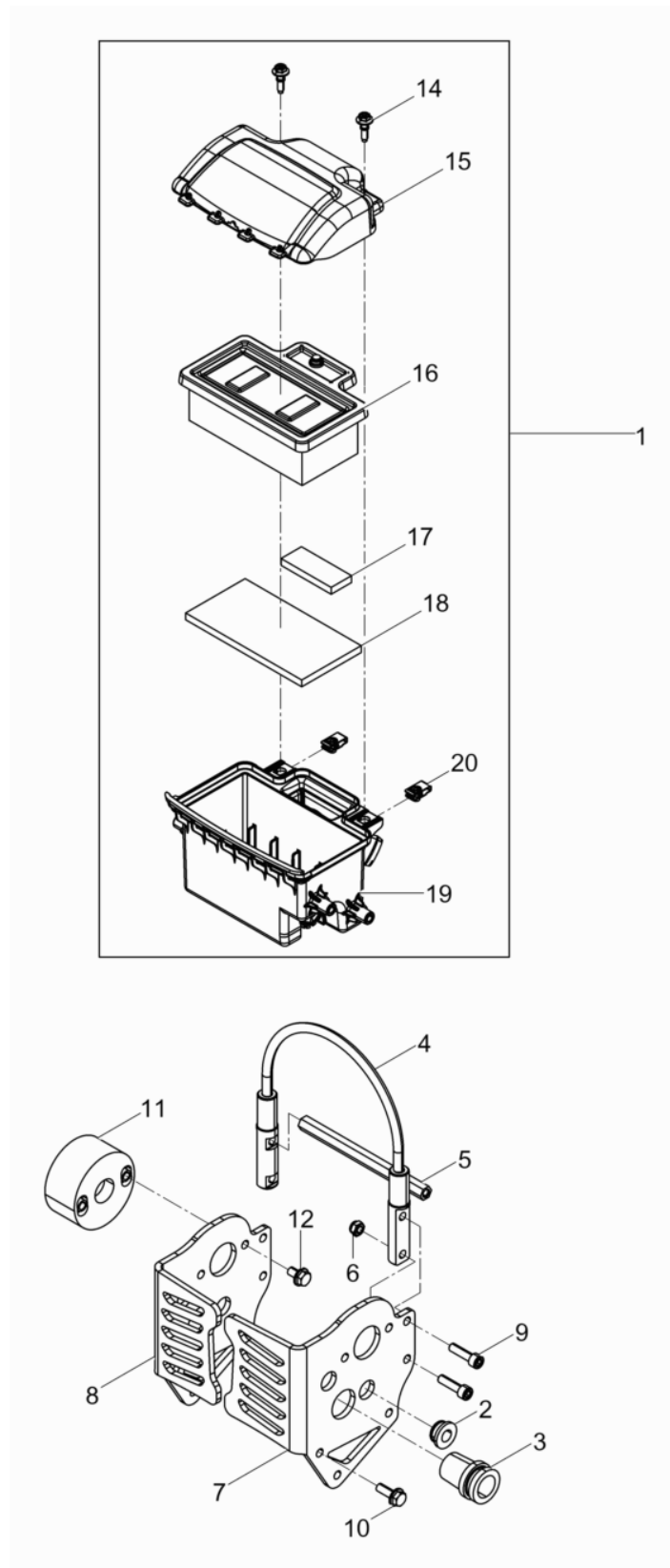



Pos. Item	Artikel Nr. Item no.	Pc.	Unit	Beschreibung Descripción	Description Description	Abm. Dim.	Norm Standard
						Drehmoment Torque	Schmierstoff Lubricant
1	5100032028	1	pc	Luftfilter Filtro del aire	Air cleaner Filtre à air		
2	5100032029	4	pc	Tülle Ojal	Grommet Passe-fil		
3	5100032050	1	pc	Tülle Ojal	Grommet Passe-fil		
4	5100032051	1	pc	Kabel Cable	Cable Câble		
5	5100032052	1	pc	Strebe Puntual	Brace Contre-fiche		
6	5000010367	2	pc	Sechskantmutter Tuerca hexagonal	Hexagon nut Écrou hexagonal		DIN985
7	5100028527	1	pc	Seitenblech Links Chapa lateral izquierda	Side plate left Tôle laterale gauche		
8	5100028528	1	pc	Seitenblech Rechts Chapa lateral derecho	Side plate right Tôle laterale droite		
9	5200023260	4	pc	Schraube Tornillo	Screw Vis		
10	5200001667	6	pc	Schraube Tornillo	Screw Vis		
11	5000156979	2	pc	Puffer Amortiguador	Shockmount Silentbloc		
12	5100027072	4	pc	Schraube Tornillo	Screw Vis		
14	5000164398	2	pc	Schraube Des Luftfilterkastens Tornillo de la caja para filtro de aire	Screw-filter, air box Vis de la boîte pour filtre à air		
15	5200007043	1	pc	Deckel Des Luftfilterkastens Tapa de la caja para filtro de aire	Air box filter cover Couvercle de la boîte pour fil		
16	5200003062	1	pc	Filtereinsatz Elemento-filtro	Air filter element Élément filtrant		
17	5200007045	1	pc	Filterelement Espume filtro	Foam filter Ecumer le filtre		
18	5200007044	1	pc	Vorfilterelement Elemento del prefiltro	Prefilter element Élément du prénettoyeur		
19	5200007041	1	pc	Unterteil Des Luftfilterkastens Parte inferior de la caja para filtro de aire	Air box base Partie inférieure de la boîte		
20	5000164397	4	pc	Klemme Des Luftfilterkastens Sujetador de la caja para filtro de aire	Air box filter clip Agrafe de la boîte pour filtre		

Stampfeinsatz Kpl.  
Ramming shoe cpl.  
Pisón cpl.  
Tête de frappe cpl.

BS50-4AS 11IN US

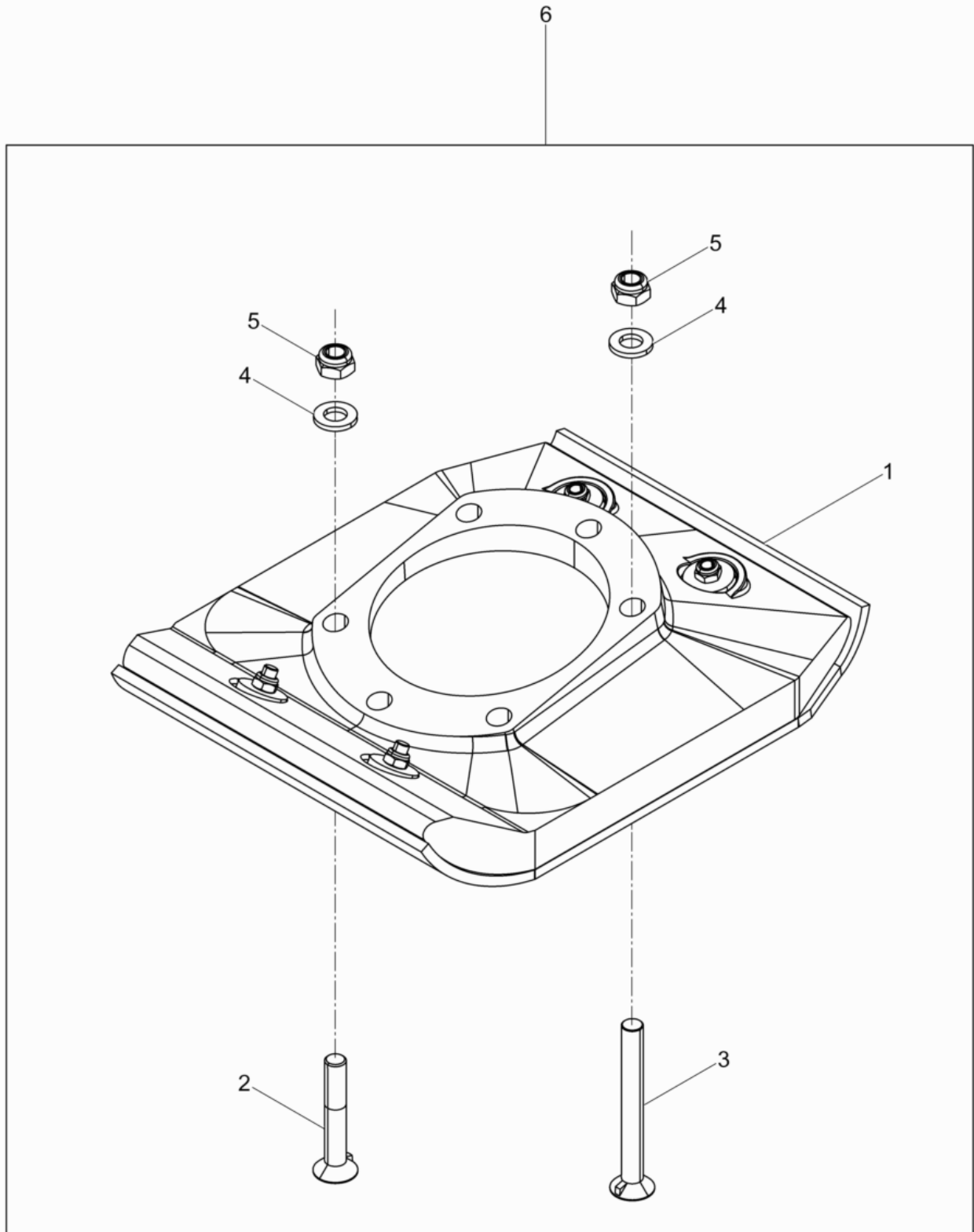

**BS50-4AS 11IN US**

**Stampfeinsatz Kpl.  
Ramming shoe cpl.  
Pisón cpl.  
Tête de frappe cpl.**

Pos. Item	Artikel Nr. Item no.	Pc.	Unit	Beschreibung Descripción	Description Description	Abm. Dim.	Norm Standard
						Drehmoment Torque	Schmierstoff Lubricant
1	5100032114	1	pc	Stampfeinsatz 11In Placa de pisón 11in	Ramming shoe 11in Sabot de frappe 11in		
2	5000011158	3	pc	Senkschraube Tornillo avellanado	Countersunk bolt Vis à tête fraisée	M12 x 75 86Nm/63ft.lbs	DIN604
3	5000012983	3	pc	Senkschraube Tornillo avellanado	Countersunk bolt Vis à tête fraisée	M12 x 110 86Nm/63ft.lbs	DIN604
4	5000021465	6	pc	Sicherungsscheibe Arandela de seguridad	Lock washer Rondelle d'arrêt	HS12	
5	5000010366	6	pc	Sechskantmutter Tuerca hexagonal	Hexagon nut Écrou hexagonal	M12X1.75	DIN985
6	5100042452	1	pc	Stampfeinsatz Kpl. 11In Pisón cpl. 11in	Ramming shoe cpl. 11in Tête de frappe cpl. 11in		



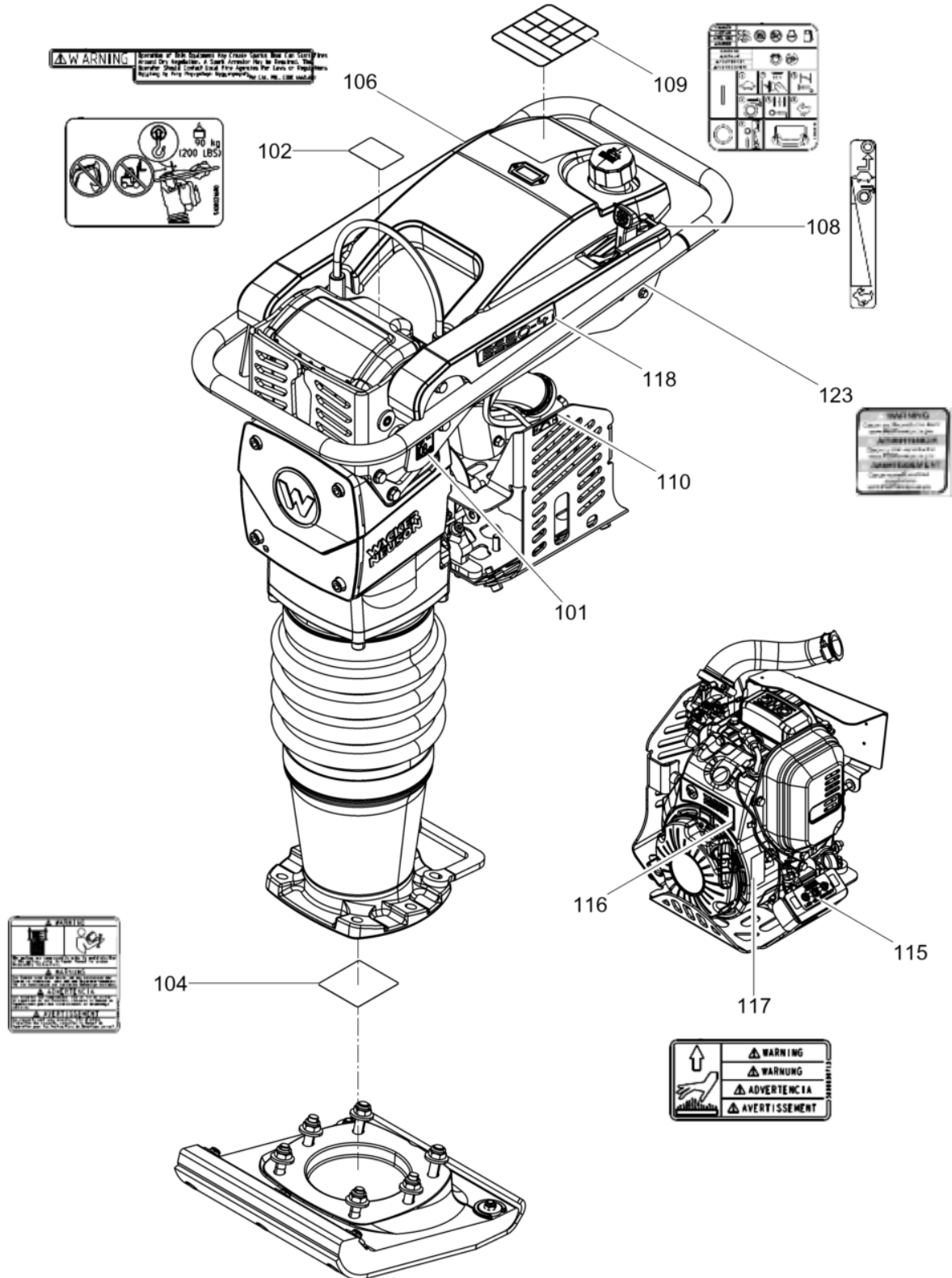

Pos. Item	Artikel Nr. Item no.	Pc.	Unit	Beschreibung Descripción	Description Description	Abm. Dim.	Norm Standard
						Drehmoment Torque	Schmierstoff Lubricant
101	5000129784	1	pc	Aufkleber-Schalleistungspegel Etiqueta autoadhesiva-nivel de potencia acúëstica	Decal-sound power level Autocollante-niveau sonore		
102	5100031690	1	pc	Aufkleber Hebepunkt Calcomania punto de elevación	Label lifting point Autocollant point de levage		
104	5100031692	1	pc	Aufkleber Druckfeder US Calcomania resorte de compresión us	Label compression spring us Autocollant ressort de		
106	5100031695	1	pc	Aufkleber Funke Calcomania centella	Label spark Autocollant flammèche		
108	5100031697	1	pc	Aufkleber Starter Calcomania arrancador	Label starter Autocollant démarreur		
109	5100031700	1	pc	Aufkleber Start / Stop Manuell US Calcomanía arranque-parada manual us	Label start-stop manual us Aufkleber start / stop auto		
110	5100031702	1	pc	Aufkleber Starter Calcomanía arrancador	Label starter Autocollant démarreur		
115	5100031710	1	pc	Aufkleber Calcomania	Label Autocollant		
116	5100031712	1	pc	Aufkleber Logo Calcomania insignia	Label logo Autocollant logo		
117	5100031713	1	pc	Aufkleber Heisse Oberfläche US Calcomania superficie caliente us	Label hot surface us Autocollant traitement de		
118	5100031723	2	pc	Aufkleber Typ Tipo etiqueta autoadhesiva	Type label Autocollant de type		
123	5100045462	1	pc	Aufkleber Calcomania	Label Autocollant		

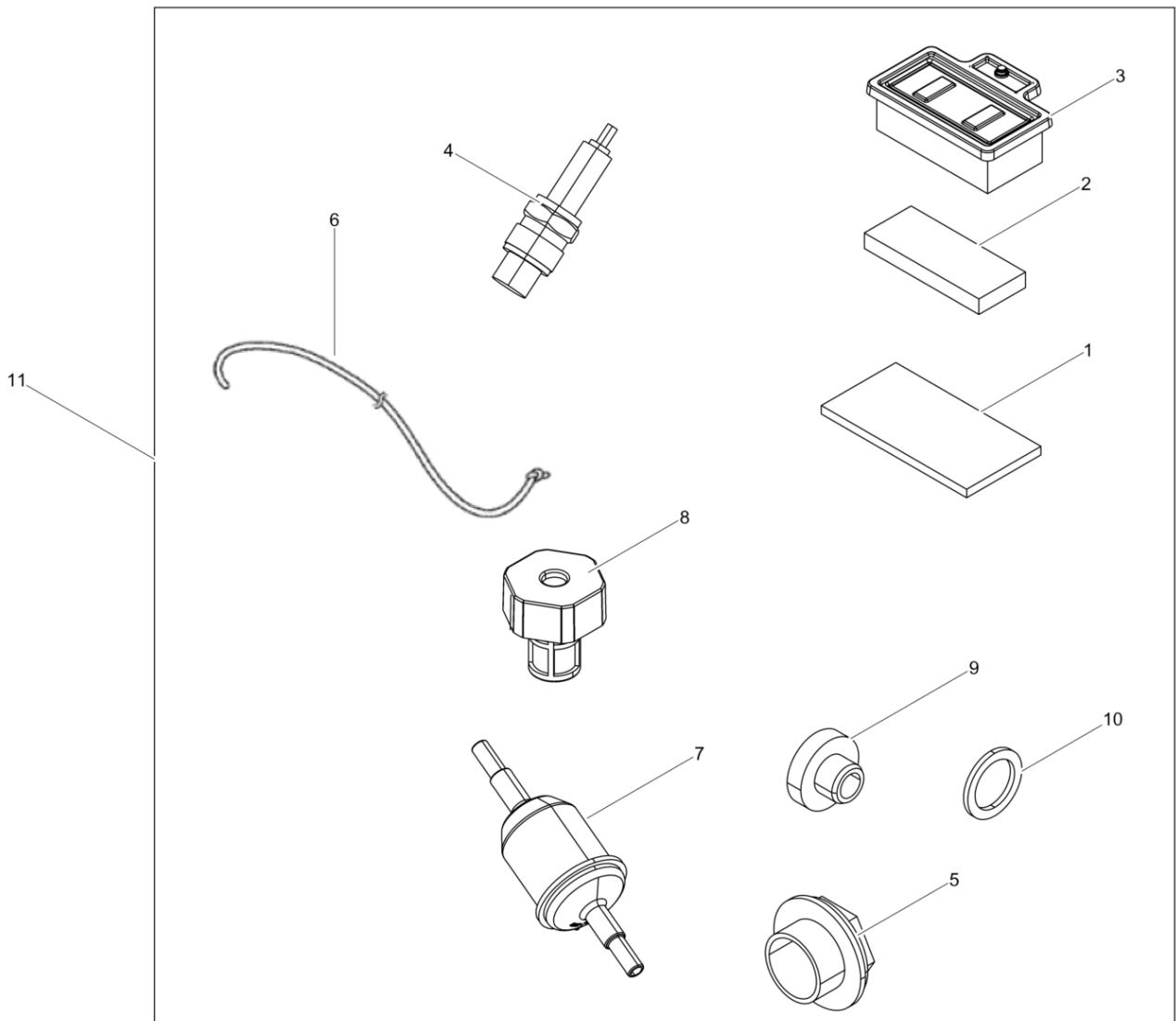

Pos. Item	Artikel Nr. Item no.	Pc.	Unit	Beschreibung Descripción	Description Description	Abm. Dim.	Norm Standard
						Drehmoment Torque	Schmierstoff Lubricant
1	5200007044	1	pc	Vorfilterelement Elemento del prefiltro	Prefilter element Élément du prénettoyeur		
2	5200007045	1	pc	Filterelement Espume filtro	Foam filter Ecumer le filtre		
3	5200003062	1	pc	Filtereinsatz Elemento-filtro	Air filter element Élément filtrant		
4	5000157610	1	pc	Zündkerze Bujía	Spark plug Bougie d'allumage		
5	5100033182	1	pc	Ölstandsauge Indicador de aceite	Sight glass Indicateur		
6	5200015249	1	pc	Seil Cuerda	Rope Corde		
7	5100068032	1	pc	Kraftstofffilter Filtro de combustible	Fuel filter Filtre à carburant		
8	5100028935	1	pc	Wasserfilter Filtro de agua	Water filter Filtre à eau		
9	5100032258	1	pc	Buchse Buje	Bush Boîte		
10	5000086312	1	pc	Dichtungsring Anillo sellador	Ring seal Rondelle à étancher		
11	5100043676	1	pc	Wartungspaket Juego para mantenimiento	Maintenance kit Jeu d'entretien		

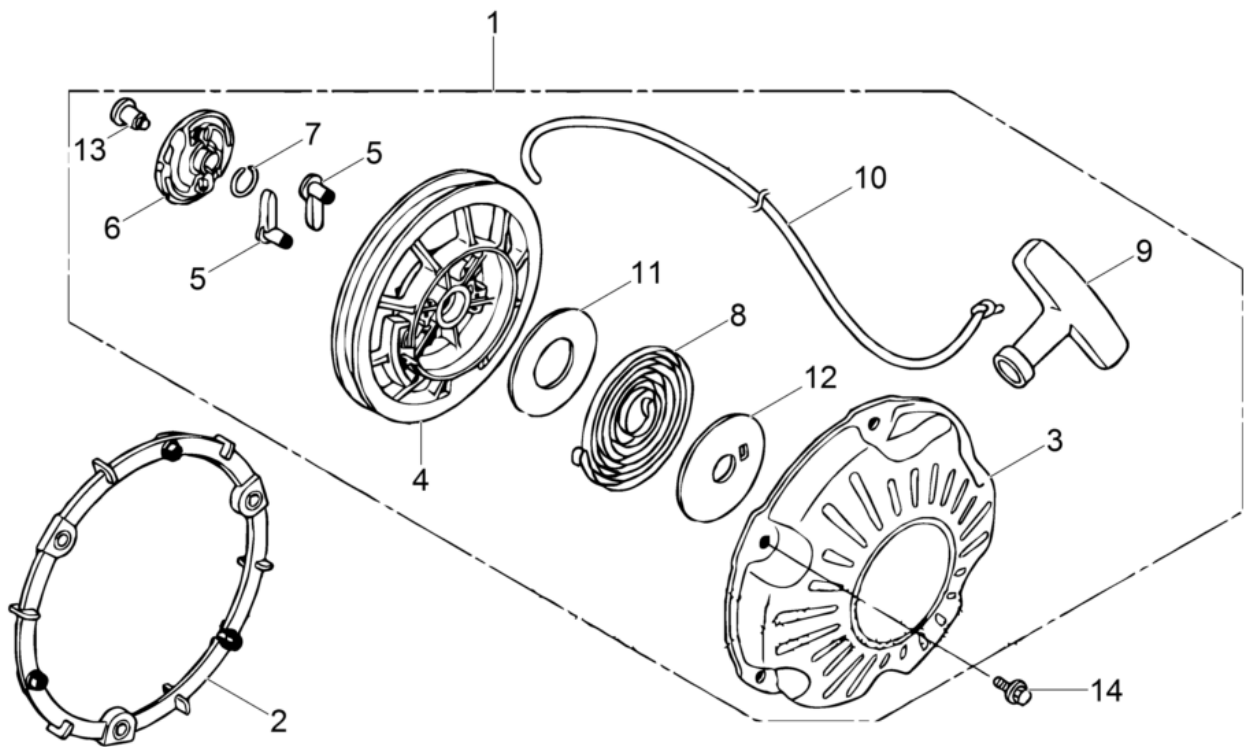



Pos. Item	Artikel Nr. Item no.	Pc.	Unit	Beschreibung Descripción	Description Description	Abm. Dim.	Norm Standard
						Drehmoment Torque	Schmierstoff Lubricant
1	5100015799	1	pc	Reversierstarter Kpl. Arrancador compl.	Recoil starter cpl. Démarrreur compl.		
1	5100031000	1	pc	Reversierstarter Kpl. Starter reversible cpl.	Recoil starter cpl. Démarrreur réversible cpl.		
2	5100015800	1	pc	Abstandsplatte Placa espaciadora	Spacer plate Plaque d'écartement		
3	5100015801	1	pc	Startergehäuse Caja del arrancador	Starter housing Carter de démarrage		
4	5200018628	1	pc	Seilscheibe Disco de cuerda	Starter reel Disque pour corde		
5	5000156728	2	pc	Ratsche Trinquete	Ratchet (pawl) Cliquet		
6	5000156729	1	pc	Führung Guía	Ratchet guide Ancre		
7	5000162073	1	pc	Reibfeder Resorte de fricción	Friction spring Ressort de friction		
8	5000081777	1	pc	Feder Resorte	Spring Ressort		
9	5200018629	1	pc	Anwerfgriff Empuñadura del arranque	Starter handle Poignée du lanceur		
10	5200015249	1	pc	Seil Cuerda	Rope Corde		
11	5000162075	1	pc	Seitenplatte Placa lateral	Side plate Plaque latérale		
12	5000162076	1	pc	Seitenplatte Placa lateral	Side plate Plaque latérale		
13	5000081782	1	pc	Schraube Tornillo	Screw Vis		
14	5000151935	3	pc	Bolzen Perno	Bolt Boulon	6 x 14	

Gebälseabdeckung  
Fan hood  
Tapa de ventilador  
Couvercle du sys. de vent.

BS50-4AS 11IN US

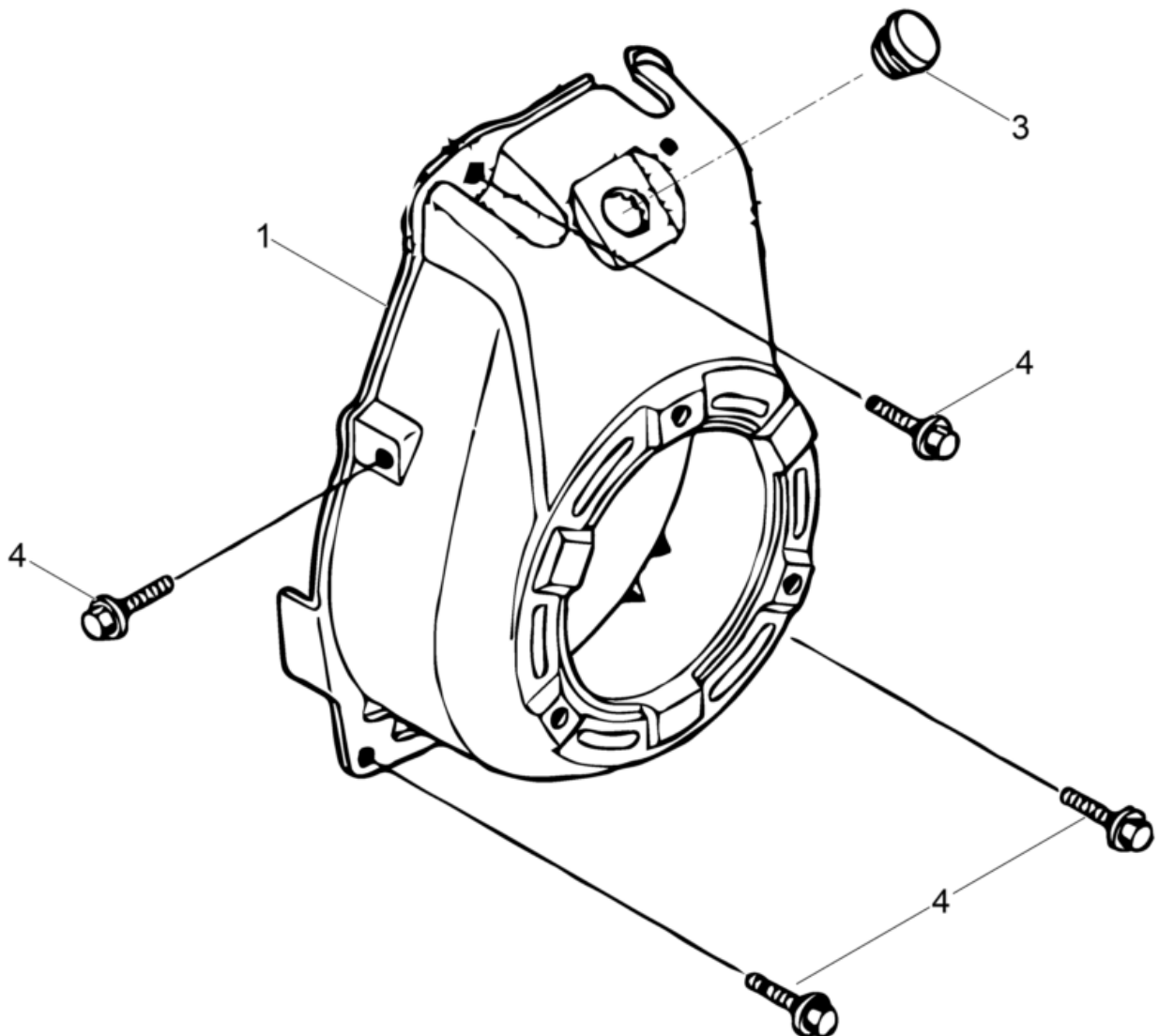

Pos. Item	Artikel Nr. Item no.	Pc.	Unit	Beschreibung Descripción	Description Description	Abm. Dim.	Norm Standard
						Drehmoment Torque	Schmierstoff Lubricant
1	5200018670	1	pc	Deckel Tapa	Cover Couvercle		
3	5000071813	1	pc	Gummistopfen Tapón de goma	Rubber plug Tampon caoutchouc	0,590in ID	
4	5000152487	4	pc	Bolzen Perno	Bolt Boulon	M6x14	

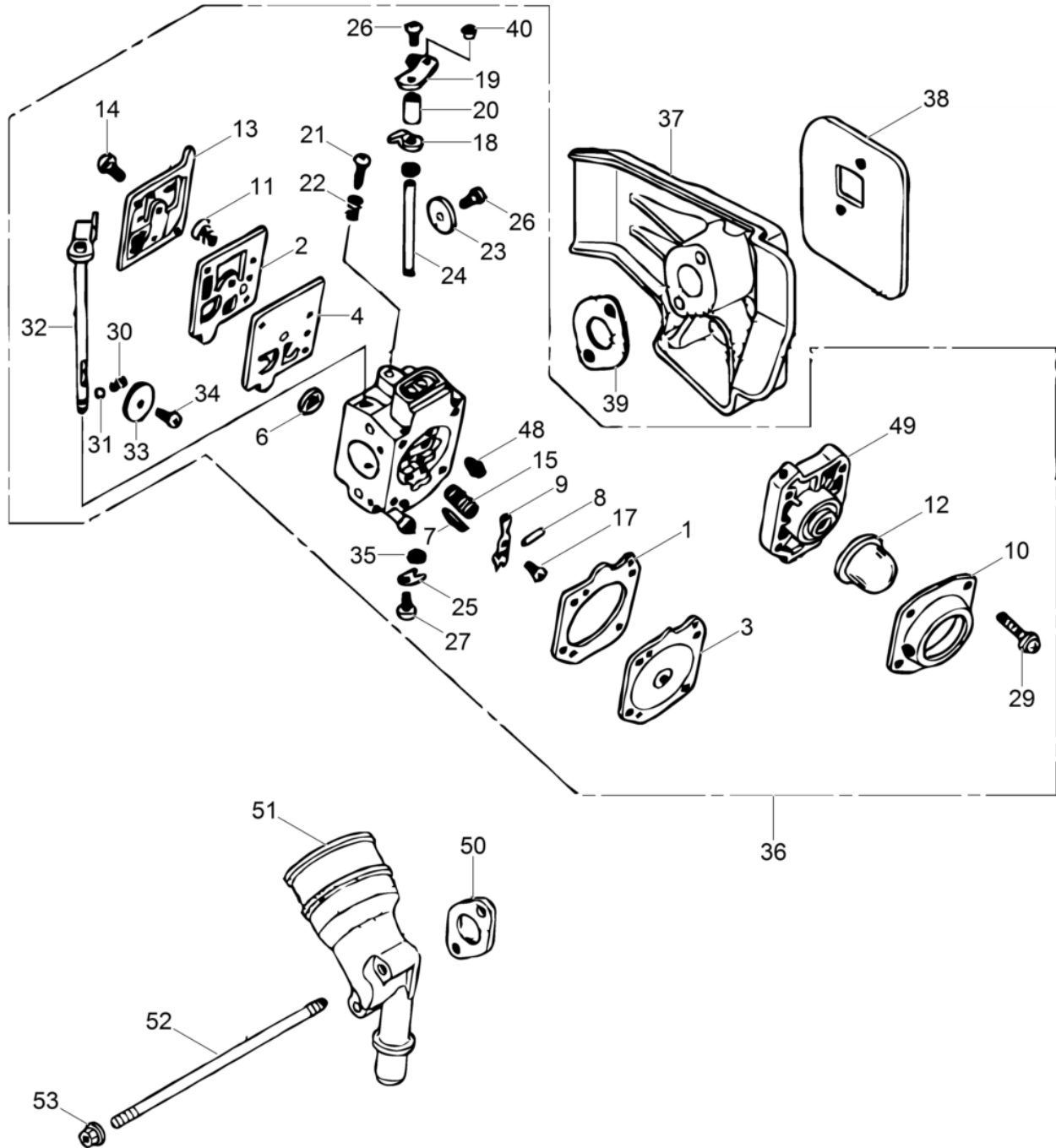

Pos. Item	Artikel Nr. Item no.	Pc.	Unit	Beschreibung Descripción	Description Description	Abm. Dim.	Norm Standard
						Drehmoment Torque	Schmierstoff Lubricant
1	5200018671	1	pc	Dichtung Junta	Gasket Joint		
2	5200015252	1	pc	Dichtung Junta	Gasket Joint		
3	5200018672	1	pc	Membran Diafragma	Diaphragm Membrane		
4	5200015254	1	pc	Pumpmembran Diafragma de bomba	Pump diaphragm Diaphragme de pompe		
6	5200015255	1	pc	Sieb Tamiz	Screen Tamis		
7	5000157497	1	pc	Nadelventil Válvula de aguja	Needle valve Soupape à pointeau		
8	5000217167	1	pc	Stift Pasador	Pin Goupille		
9	5200015256	1	pc	Hebel Palanca	Lever Levier		
10	5200018673	1	pc	Deckel Tapa	Cover Couvercle		
11	5000157508	1	pc	Feder Resorte	Spring Ressort		
12	5200018674	1	pc	Anlaßeinspritzpumpe Imprimador	Primer Dispositif d'injection au déma		
13	5200018675	1	pc	Deckel Tapa	Cover Couvercle		
14	5200015258	1	pc	Schraube Tornillo	Screw Vis		
15	5200015259	1	pc	Feder Resorte	Spring Ressort		
17	5200018676	1	pc	Schraube Tornillo	Screw Vis		
18	5100031001	1	pc	Anschlag Dispositivo limitador	Limit stop Dispositif limiteur		
19	5200018677	1	pc	Gashebel Palanca del acelerador	Throttle control lever Levier des gaz		
20	5200015265	1	pc	Abstandsstück Espaciador	Spacer Entretoise		
21	5200018678	1	pc	Einstellschraube Tornillo de ajuste	Adjustment screw Vis d'ajustage		
22	5200015267	1	pc	Feder Resorte	Spring Ressort		
23	5200018679	1	pc	Ventil Válvula	Valve Soupape		
24	5200015269	1	pc	Welle Eje	Shaft Arbre		
25	5200015270	1	pc	Halteclip Presilla de retención	Retaining clip Clé de serrage		
26	5200015264	2	pc	Schraube Tornillo	Screw Vis		
27	5200015272	1	pc	Gewindestift Tornillo	Setscrew Vis		
29	5200018694	4	pc	Schraube Tornillo	Screw Vis		
30	5200015273	1	pc	Feder Resorte	Spring Ressort		
31	5200015274	1	pc	Kugel Bola	Ball Bille		

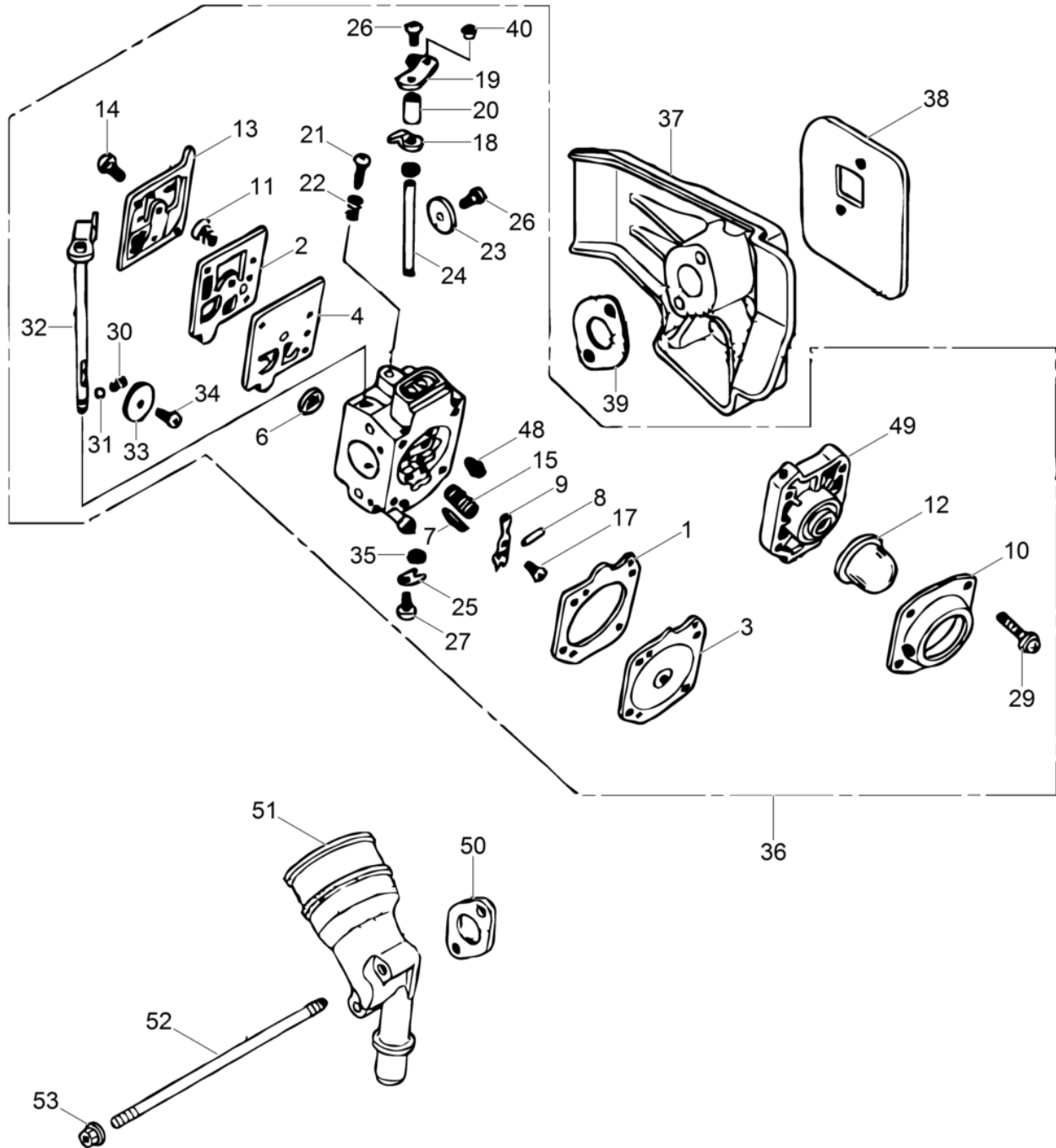

Pos. Item	Artikel Nr. Item no.	Pc.	Unit	Beschreibung Descripción	Description Description	Abm. Dim.	Norm Standard
						Drehmoment Torque	Schmierstoff Lubricant
32	5200015275	1	pc	Chokewelle Kpl. Eje estrangulador compl.	Choke shaft cpl. Arbre étrangleur compl.		
33	5200015276	1	pc	Ventil Válvula	Valve Soupape		
34	5200015277	1	pc	Schraube Tornillo	Screw Vis		
35	5200015278	2	pc	Dichtung Empaque	Seal Joint		
36	5100015802	1	pc	Vergaser Kpl. Carburador compl.	Carburetor cpl. Carbureteur compl.		
37	5100015803	1	pc	Isolator Aislador	Insulator Isolant		
38	5200015281	1	pc	Dichtung Junta	Gasket Joint		
39	5200015285	1	pc	Dichtung Junta	Gasket Joint		
40	5100015804	1	pc	Reglerstange Varilla	Governor rod Tringle		
48	5100015805	1	pc	Hauptdüse Chicler principal	Main jet Gicleur principal	46	
48	5100015806	1	pc	Hauptdüse Chicler principal	Main jet Gicleur principal	48	
48	5200015288	1	pc	Hauptdüse Chicler principal	Main jet Gicleur principal	50	
49	5200018696	1	pc	Gehäuse Cuerpo	Body Corps		
50	5200015305	1	pc	Dichtung Junta	Gasket Joint		
51	5200018697	1	pc	Krümmen Kpl. Codo compl.	Elbow cpl. Coude compl.		
52	5100015807	2	pc	Gewindebolzen Perno prisionero	Stud bolt Boulon	M5 x 95	
53	5000156650	2	pc	Flanschmutter Tuerca de brida	Flange nut Écrou à bride	M5	

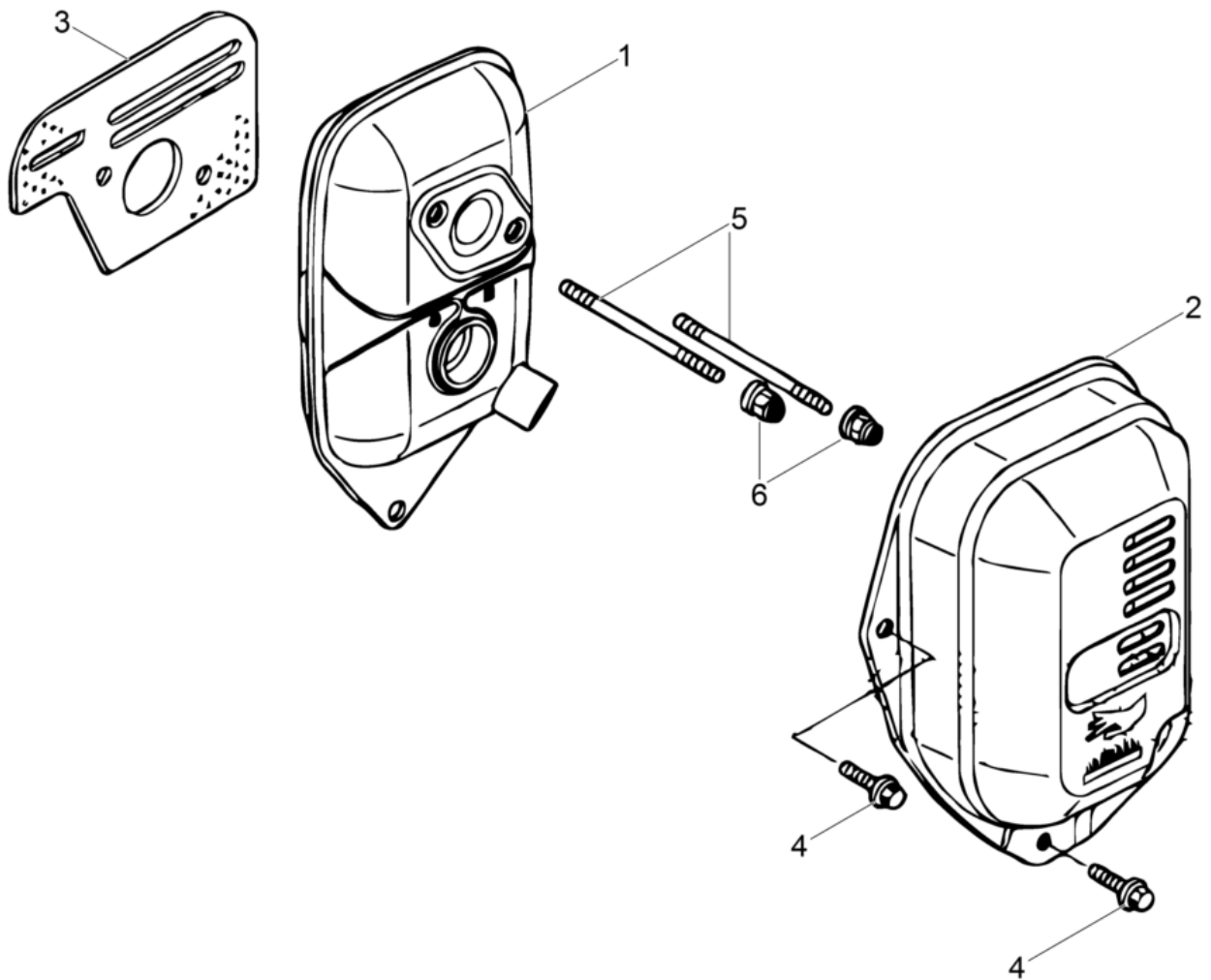



Pos. Item	Artikel Nr. Item no.	Pc.	Unit	Beschreibung Descripción	Description Description	Abm. Dim.	Norm Standard
						Drehmoment Torque	Schmierstoff Lubricant
1	5100015808	1	pc	Auspufftopf Kpl. Silenciador compl.	Muffler cpl. Pot d'échappement compl.		
2	5100015809	1	pc	Auspufftopfabdeckung Tapa del silenciador	Muffler cover Couvercle de pot d'échappement		
3	5000162104	1	pc	Dichtung Junta	Gasket Joint		
4	5000152487	3	pc	Bolzen Perno	Bolt Boulon	M6x14	
5	5100015810	2	pc	Gewindebolzen Perno prisionero	Stud bolt Boulon	M6 x 56	
6	5000209834	2	pc	Sicherungsmutter Contratuerca	Lock nut Contre-écrou		

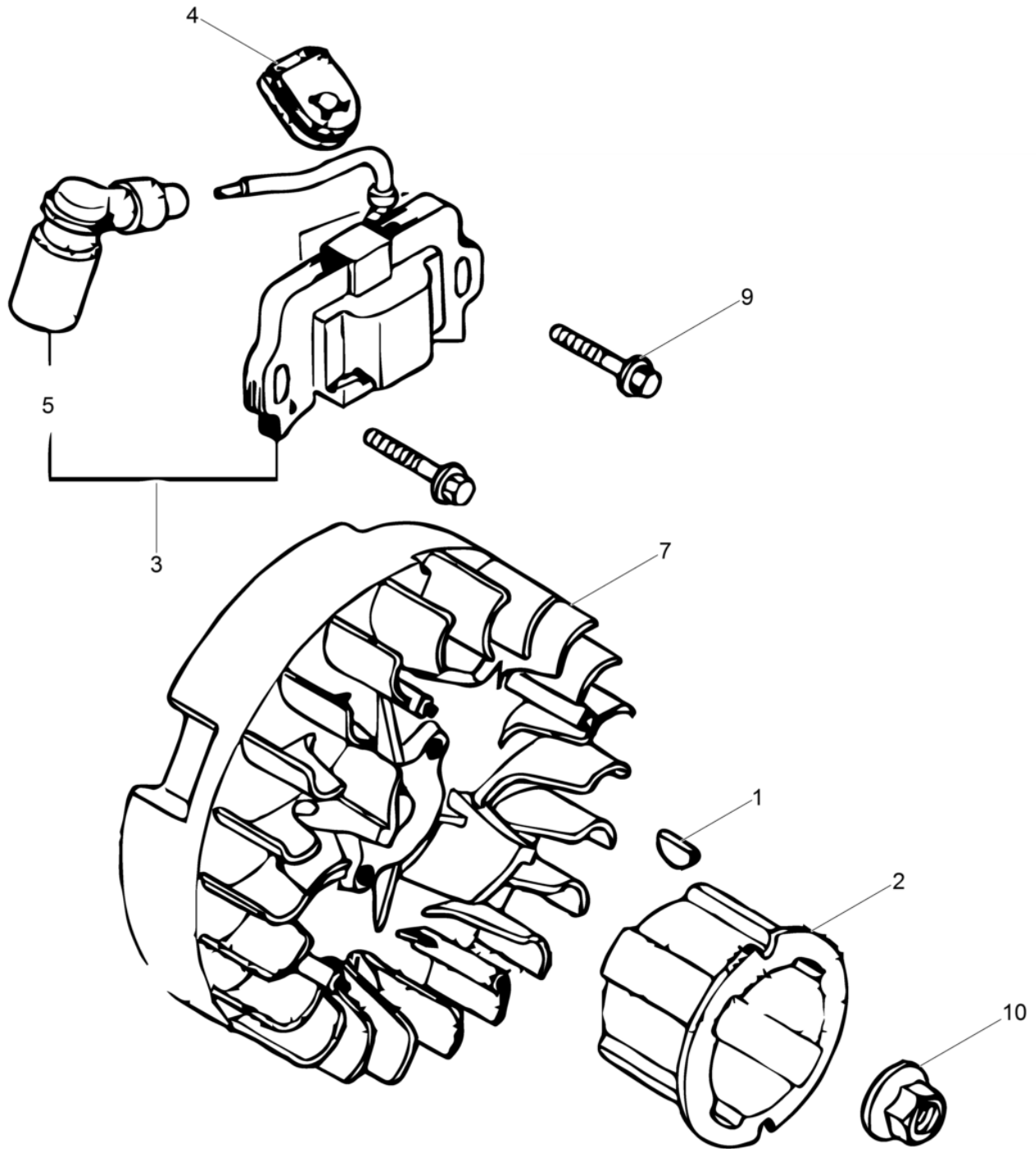

Pos. Item	Artikel Nr. Item no.	Pc.	Unit	Beschreibung Descripción	Description Description	Abm. Dim.	Norm Standard
						Drehmoment Torque	Schmierstoff Lubricant
1	5000068967	1	pc	Keil Chaveta woodruff	Woodruff key Clavette woodruff	25 x 18	
2	5100015811	1	pc	Starterscheibe Polea	Starter pulley Poulie de démarrage		
3	5200015316	1	pc	Zündspule Bobina de encendido	Ignition coil Bobine d'allumage		
4	5000162120	1	pc	Tülle Ojal	Grommet Passe-fil		
5	5200015317	1	pc	Zündkerzenstecker Capuchón de bujía	Spark plug (terminal) cap Capuchon de bougie		
7	5100015812	1	pc	Schwungrad Volante	Flywheel Volant		
9	5000071055	2	pc	Schraube Tornillo	Screw Vis	M6 x 20 10Nm/7ft.lbs	
10	5000162686	1	pc	Mutter Tuerca	Nut Écrou	M14	

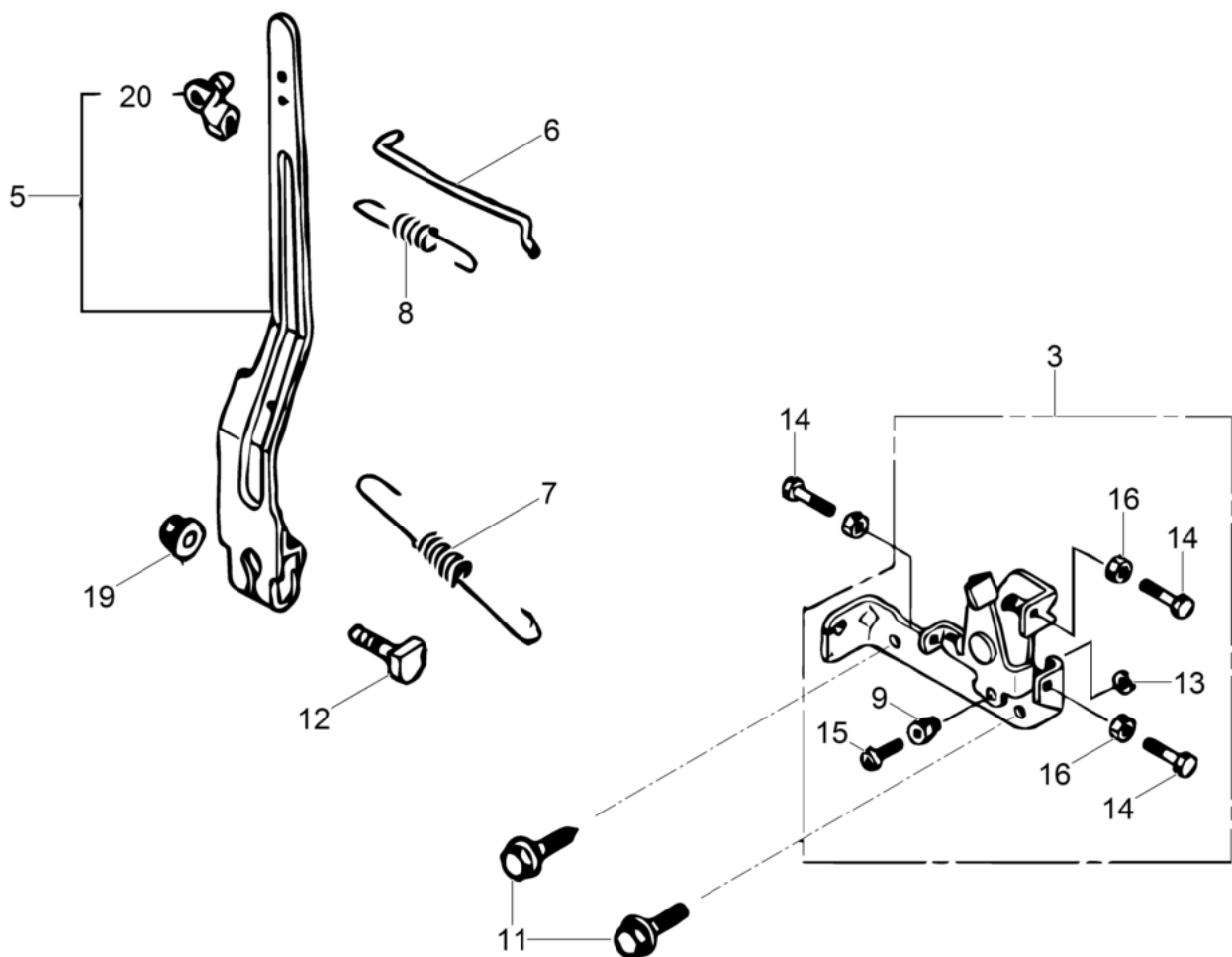

Pos. Item	Artikel Nr. Item no.	Pc.	Unit	Beschreibung Descripción	Description Description	Abm. Dim.	Norm Standard
						Drehmoment Torque	Schmierstoff Lubricant
3	5200018709	1	pc	Betätigung Kpl. Regulador compl.	Control cpl. Commande compl.		
5	5200015319	1	pc	Reglerhebelkonsole Soporte de palanca del regulador	Governor control bracket Support de levier régulateur		
6	5200015320	1	pc	Reglerstange Varilla	Governor rod Tringle		
7	5100015814	1	pc	Reglerfeder Resorte del regulador	Governor spring Ressort régulateur		
8	5100015815	1	pc	Feder Resorte	Spring Ressort		
9	5000151819	1	pc	Klemmstück Pieza de fijación	Clamping piece Pièce de serrage		
11	5000152487	2	pc	Bolzen Perno	Bolt Boulon	M6x14	
12	5200000457	1	pc	Bolzen Perno	Bolt Boulon		
13	5000151823	1	pc	Sicherungsscheibe Arandela de seguridad	Lock washer Rondelle d'arrêt	5	
14	5200015327	2	pc	Bolzen Perno	Bolt Boulon	4 x 6	
15	5000151824	1	pc	Schraube Tornillo	Screw Vis	M 4x6	
16	5200015328	2	pc	Sechskantmutter Tuerca hexagonal	Hexagon nut Écrou hexagonal	5	
19	5000071056	1	pc	Mutter Tuerca	Nut Ecrou	M6	
20	5000152475	1	pc	Stange Varilla	Rod Tige		

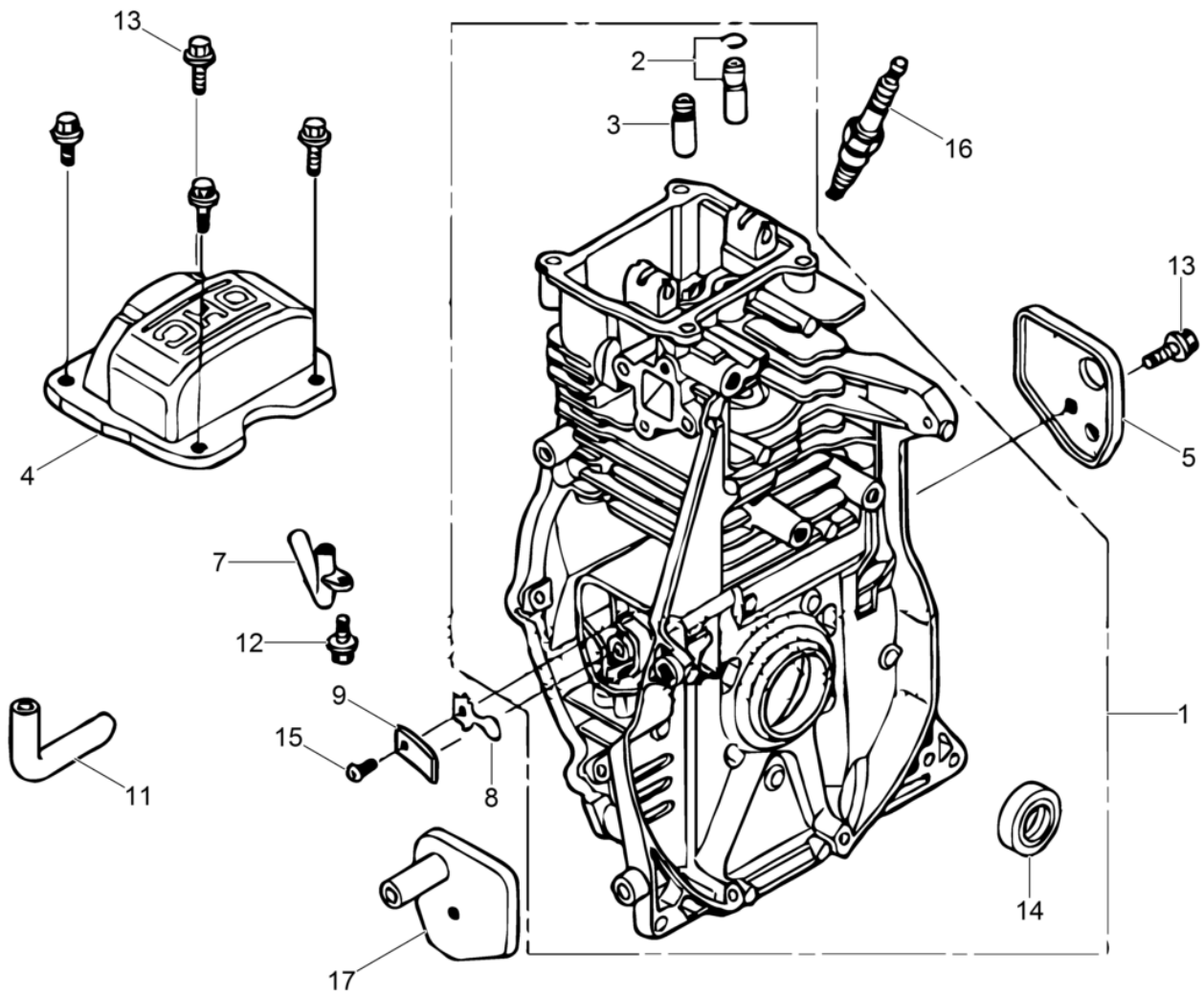

Pos. Item	Artikel Nr. Item no.	Pc.	Unit	Beschreibung Descripción	Description Description	Abm. Dim.	Norm Standard
						Drehmoment Torque	Schmierstoff Lubricant
1	5100015790	1	pc	Kurbelgehäuse Kpl. Cárter compl.	Crankcase cpl. Carter compl.		
2	5000162134	1	pc	Führung Guía	Guide Guide		
3	5000162135	1	pc	Ventilführung Guíaválvula	Valve guide Guide de soupape		
4	5000162136	1	pc	Zylinderkopf Culata	Cylinder head Culasse		
5	5000162137	1	pc	Deckel Tapa	Cover Couvercle		
7	5200018711	1	pc	Entlüftungsrohr Tubo respiradero	Breather tube Tube reniflard		
8	5200018712	1	pc	Ventil Válvula	Valve Soupape		
9	5000162140	1	pc	Platte Placa	Plate Plaque		
11	5200018714	1	pc	Entlüftungsrohr Tubo respiradero	Breather tube Tube reniflard		
12	5200015332	1	pc	Flanschbolzen Perno de reborde	Flange bolt Boulon à bride	4 x 10	
13	5000152487	6	pc	Bolzen Perno	Bolt Boulon	M6x14	
14	5000070962	1	pc	Wellendichtring Sello del eje	Shaft seal Bague d'étanchéité		
15	5000157555	1	pc	Flachkopfschraube Tornillo de cabeza de cono achatado	Pan head screw Vis ber	M3 x 5	
16	5000157610	1	pc	Zündkerze Bujía	Spark plug Bougie d'allumage		
17	5200018713	1	pc	Deckel Tapa	Cover Couvercle		

Kurbelgehäuseabdeckung  
Crankcase cover  
Cubierta da la caja de manivel  
Couvercle carter de manivelle

BS50-4AS 11IN US

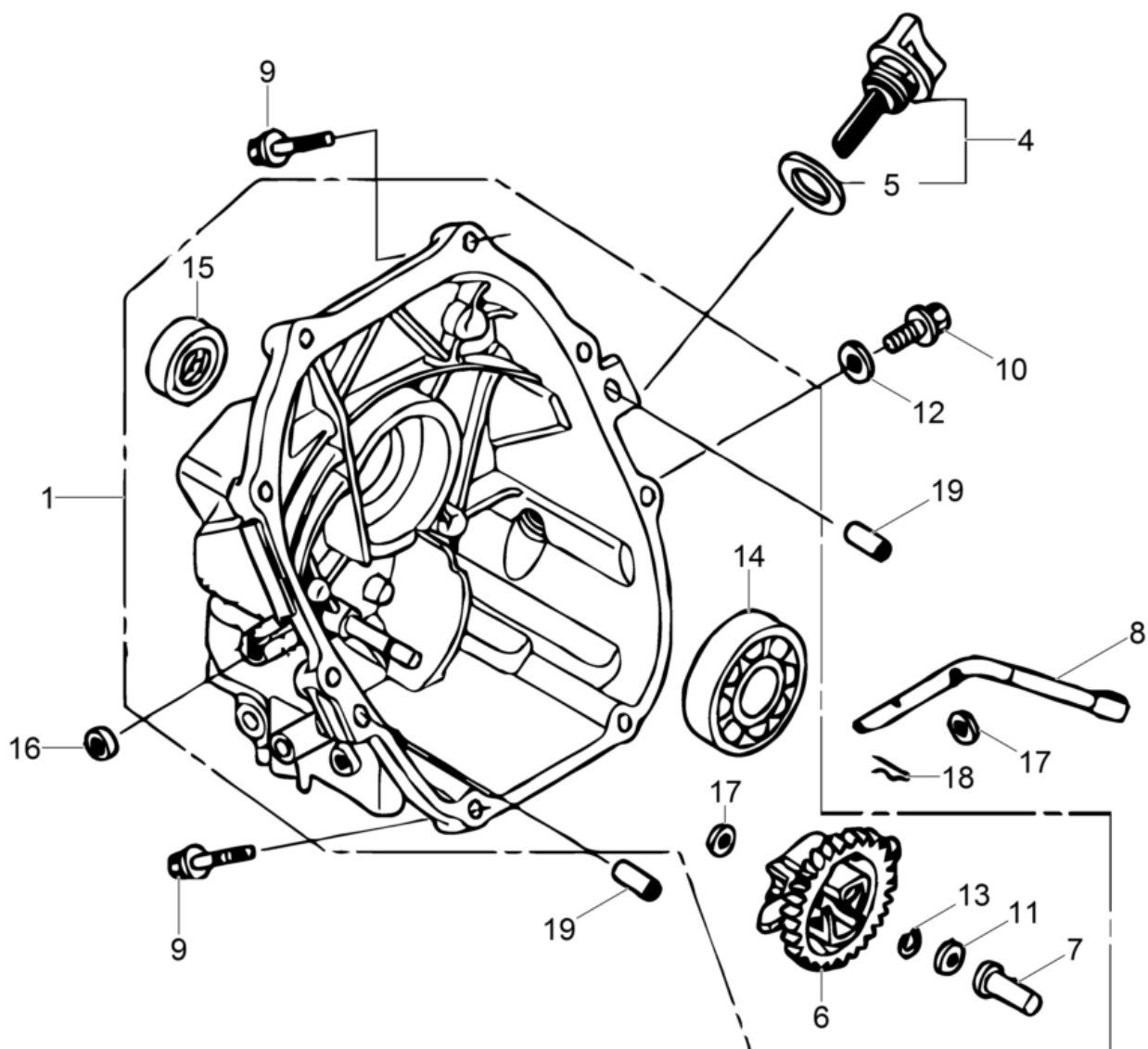



Pos. Item	Artikel Nr. Item no.	Pc.	Unit	Beschreibung Descripción	Description Description	Abm. Dim.	Norm Standard
						Drehmoment Torque	Schmierstoff Lubricant
1	5100015791	1	pc	Deckel Kpl. Tapa compl.	Cover cpl. Couvercle compl.		
4	5000217161	1	pc	Kappe-Ölfüller Llenador de aceite	Oil filler cap Remplisseur d'huile		
5	5000162647	1	pc	Dichtung Junta de estanqueidad	Gasket Garniture		
6	5000162152	1	pc	Regler Kpl. Regulador compl.	Governor cpl. Régulateur compl.		
7	5000070953	1	pc	Gleitstück Manguito	Slider Douille		
8	5000162153	1	pc	Reglerwelle Eje de regulador	Governor shaft Arbre régulateur		
9	5000081737	8	pc	Schraube Tornillo	Screw Vis	M6 x 25	
10	5000070964	1	pc	Verschlusschraube Tapón roscado	Plug (threaded) Bouchon		
11	5000070959	1	pc	Scheibe Arandela	Washer Rondelle		
12	5000070963	1	pc	Scheibe Arandela	Washer Rondelle		
13	5000081615	1	pc	Sicherungsring Anillo de retención	Retaining ring Bague d'arrêt		
14	5000070961	1	pc	Rillenkugellager Rodamiento de bolas	Grooved ball bearing Roulement à billes		
15	5000070969	1	pc	Wellendichtring Sello del eje	Shaft seal Bague d'étanchéité		
16	5200015335	1	pc	Öldichtung Empaque de aceite	Oil seal Joint d'huile	6 x 16 x 4	
17	5000071639	2	pc	Scheibe Arandela	Washer Rondelle	6M	
18	5000054033	1	pc	Stift Pasador	Pin Goupille		
19	5000162155	2	pc	Paßstift Espiga	Dowel pin Cheville		

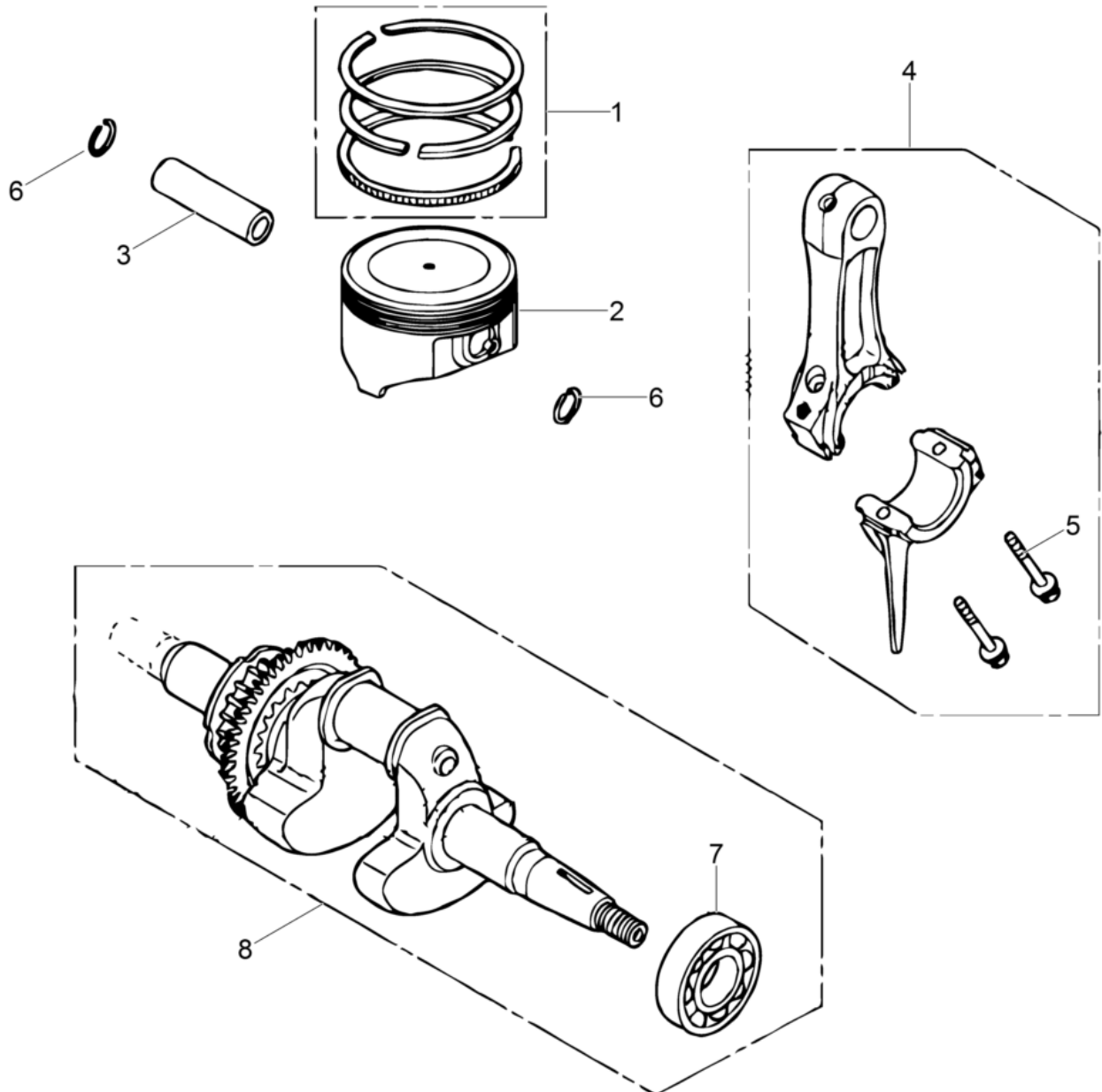

Pos. Item	Artikel Nr. Item no.	Pc.	Unit	Beschreibung Descripción	Description Description	Abm. Dim.	Norm Standard
						Drehmoment Torque	Schmierstoff Lubricant
1	5100015794	1	pc	Kolbenringsatz Juego de anillos	Piston ring set Jeu de segments		
2	5100015795	1	pc	Kolben Pistón	Piston Piston		
3	5000071008	1	pc	Kolbenbolzen Pasador de pistón	Piston pin Axe de piston		
4	5100015796	1	pc	Pleuel Biela	Connecting rod Bielle		
5	5100015798	2	pc	Schraube Tornillo	Screw Vis	M6 x 32	
6	5000081751	2	pc	Sicherungsring Anillo de retención	Retaining ring Bague d'arrêt		
7	5100015792	1	pc	Kugellager Rodamiento de bolas	Ball bearing Roulement à billes		
8	5100015793	1	pc	Kurbelwelle Cigüeñal	Crankshaft Vilebrequin		

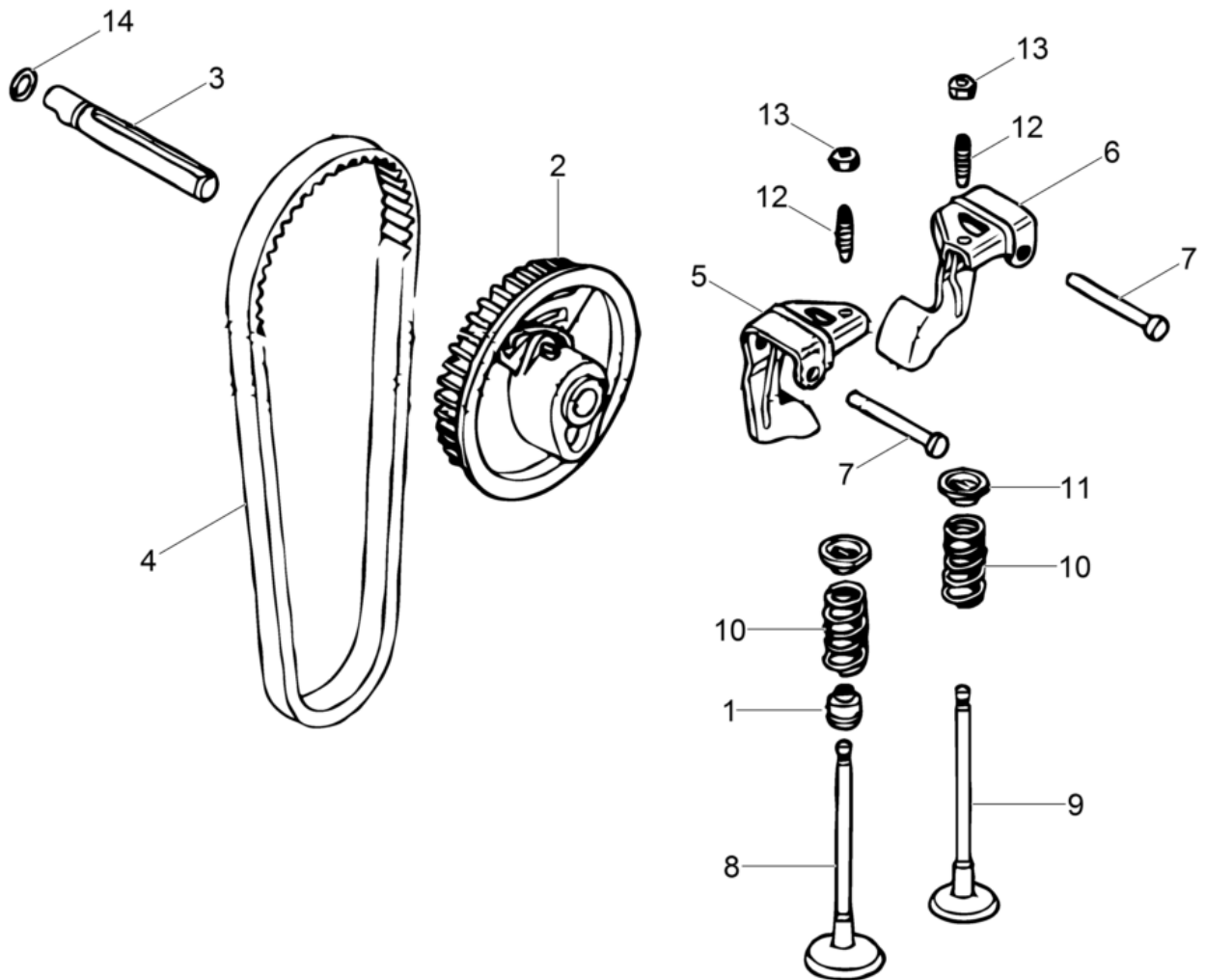

Pos. Item	Artikel Nr. Item no.	Pc.	Unit	Beschreibung Descripción	Description Description	Abm. Dim.	Norm Standard
						Drehmoment Torque	Schmierstoff Lubricant
1	5000162176	1	pc	Dichtung Empaque	Seal Joint		
2	5200018718	1	pc	Scheibe Polea	Pulley Poulie		
3	5000162165	1	pc	Nockenwelle Arbol de levas	Camshaft Arbre à cames		
4	5000162166	1	pc	Synchronriemen Correa de sincronización	Timing belt Courroie de synchronisation		
5	5200018719	1	pc	Einlaßkipphebel Balancín de admisión	Inlet rocker arm Culbuteur		
6	5200018720	1	pc	Auslaßkipphebel Balancín de escape	Exhaust rocker arm Culbuteur		
7	5000162169	2	pc	Kipphebelwelle Eje del balancín	Rocker arm shaft Arbre du culbuteur		
8	5000162170	1	pc	Einlaßventil Válvula de admisión	Intake valve Soupape d'admission		
9	5000162171	1	pc	Auslaßventil Válvula de escape	Exhaust valve Soupape d'échappement		
10	5000162172	2	pc	Ventilfeder Resorte de válvula	Valve spring Ressort de soupape		
11	5000157487	2	pc	Federteller Seguro de válvula	Valve holder Porte-soupape		
12	5000162173	2	pc	Stößeleinstellschraube Tornillo de ajuste de alzaválvulas	Tappet adjusting screw Vis de réglage de poussoir		
13	5000162174	2	pc	Gegenmutter Contratuerca	Tappet adjusting nut Contre-écrou		
14	5000162175	1	pc	O-Ring Anillo-o	O-ring Joint torique	6,8 x 1,9	

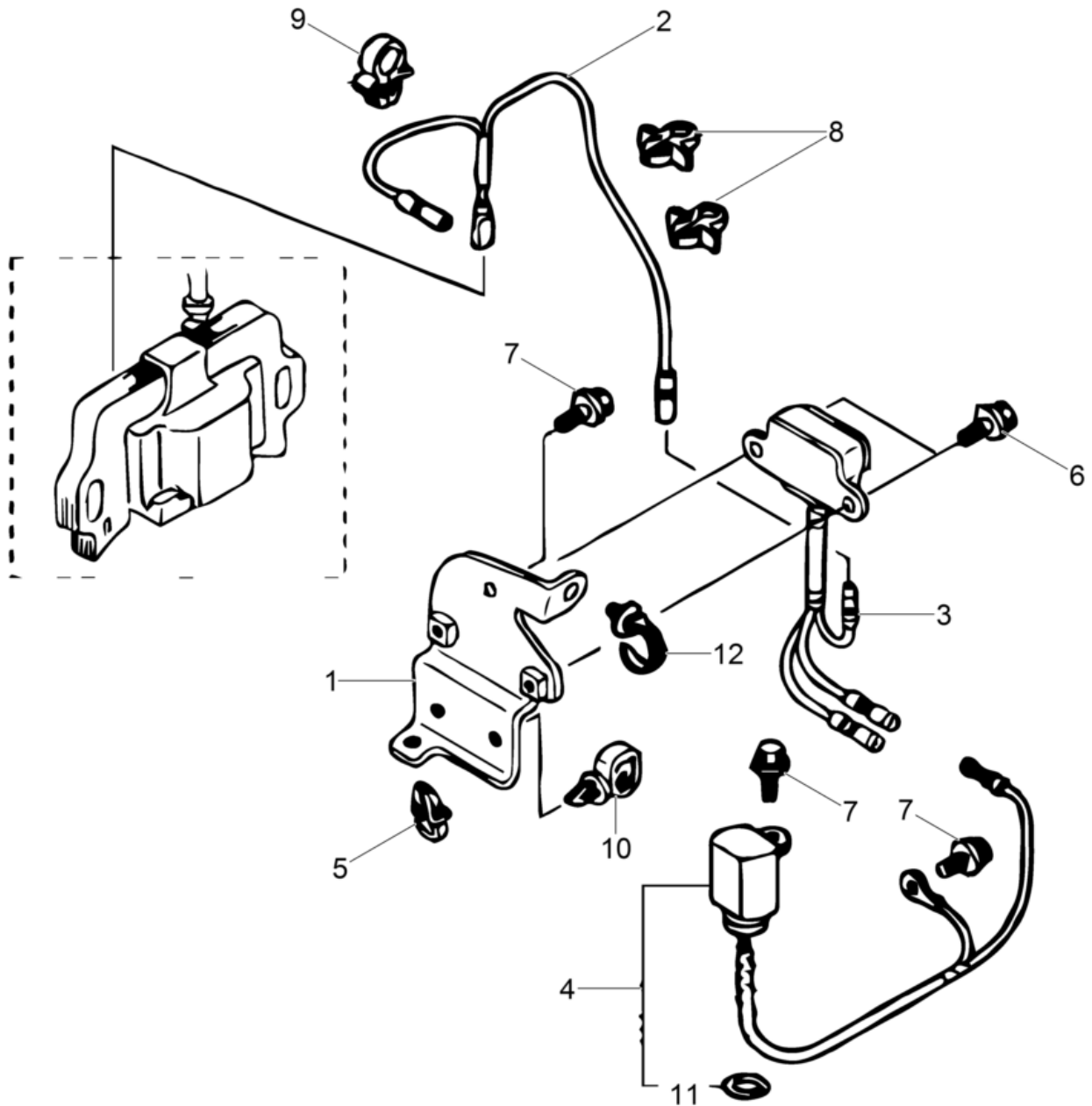

Pos. Item	Artikel Nr. Item no.	Pc.	Unit	Beschreibung Descripción	Description Description	Abm. Dim.	Norm Standard
						Drehmoment Torque	Schmierstoff Lubricant
1	5100015813	1	pc	Konsole Ménsula	Mounting bracket Support		
2	5200018701	1	pc	Kabel Alambre	Wire Fil		
3	5200018702	1	pc	Ölwarnschalter Modulo-interruptor	Oil alert switch cpl. Module-contacteur		
4	5200018703	1	pc	Ölschalter Kpl. Interruptor de aceite compl.	Oil switch cpl. Interrupteur de huile compl.		
5	5000070978	1	pc	Halter Soporte	Holder Attache		
6	5200018704	2	pc	Flanschbolzen Perno de reborde	Flange bolt Boulon à bride	M5 x 8	
7	5000152487	4	pc	Bolzen Perno	Bolt Boulon	M6x14	
8	5200018705	2	pc	Befestigung Clip	Clip Clip		
9	5000151800	1	pc	Klemme Abrazadera	Clamp Pince		
10	5200018706	1	pc	Befestigung Clip	Clip Clip	25	
11	5200018707	1	pc	O-Ring Anillo-o	O-ring Joint torique	11,80 x 2,40	
12	5200018708	1	pc	Manschette Collar	Collar Collet		

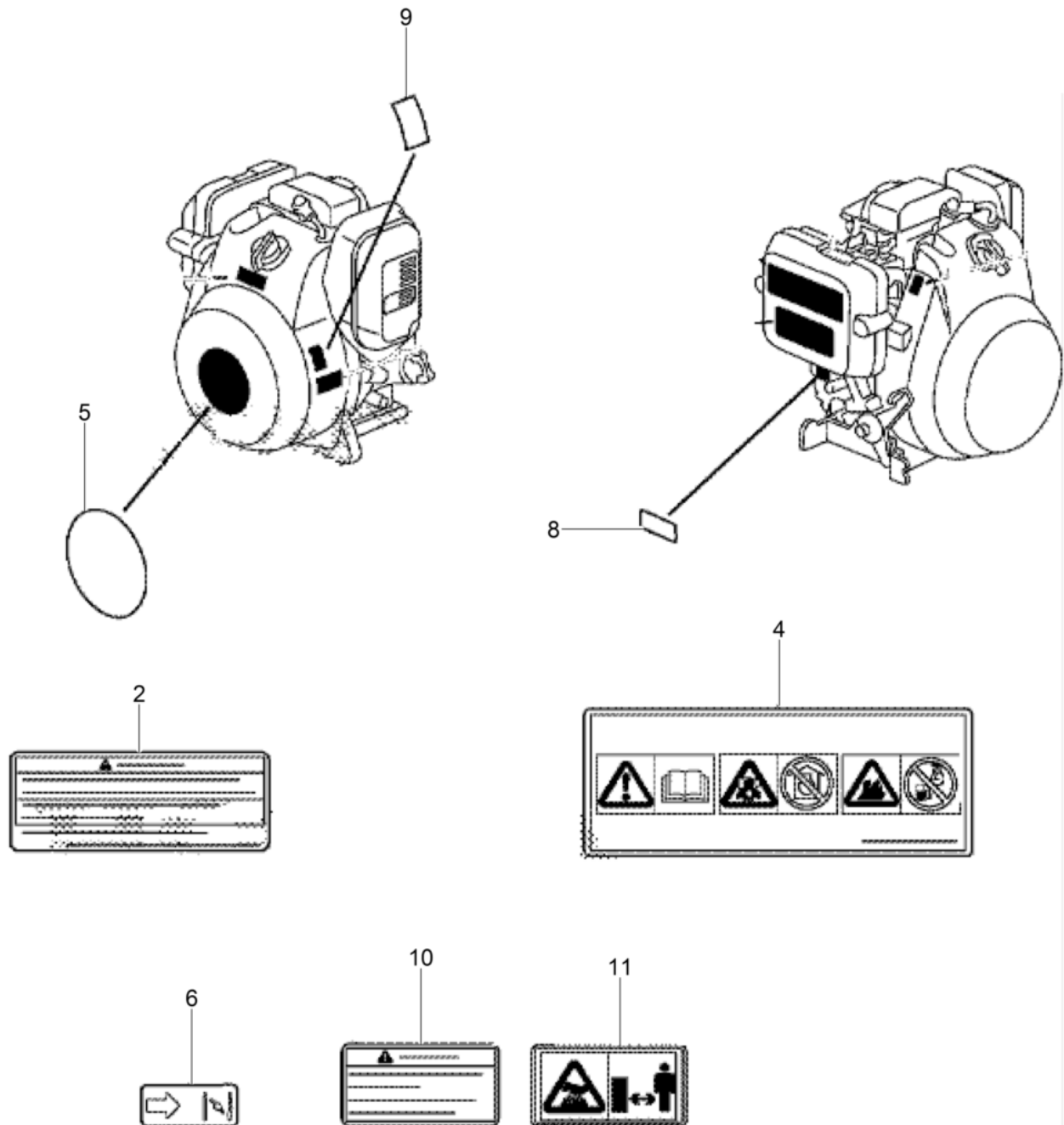



Pos. Item	Artikel Nr. Item no.	Pc.	Unit	Beschreibung Descripción	Description Description	Abm. Dim.	Norm Standard
						Drehmoment Torque	Schmierstoff Lubricant
2	5100031005	1	pc	Aufkleber Calcomania	Label Autocollant		
2	5100031006	1	pc	Aufkleber Calcomania	Label Autocollant		
4	5100031007	1	pc	Aufkleber Calcomania	Label Autocollant		
5	5100031002	1	pc	Aufkleber Calcomania	Label Autocollant		
6	5000162131	1	pc	Aufkleber Calcomania	Label Autocollant		
8	5100031003	1	pc	Aufkleber Calcomania	Label Autocollant		
9	5100005337	1	pc	Aufkleber Calcomania	Label Autocollant		
10	5100005339	1	pc	Aufkleber Calcomania	Label Autocollant		
11	5100005340	1	pc	Aufkleber Calcomania	Label Autocollant		

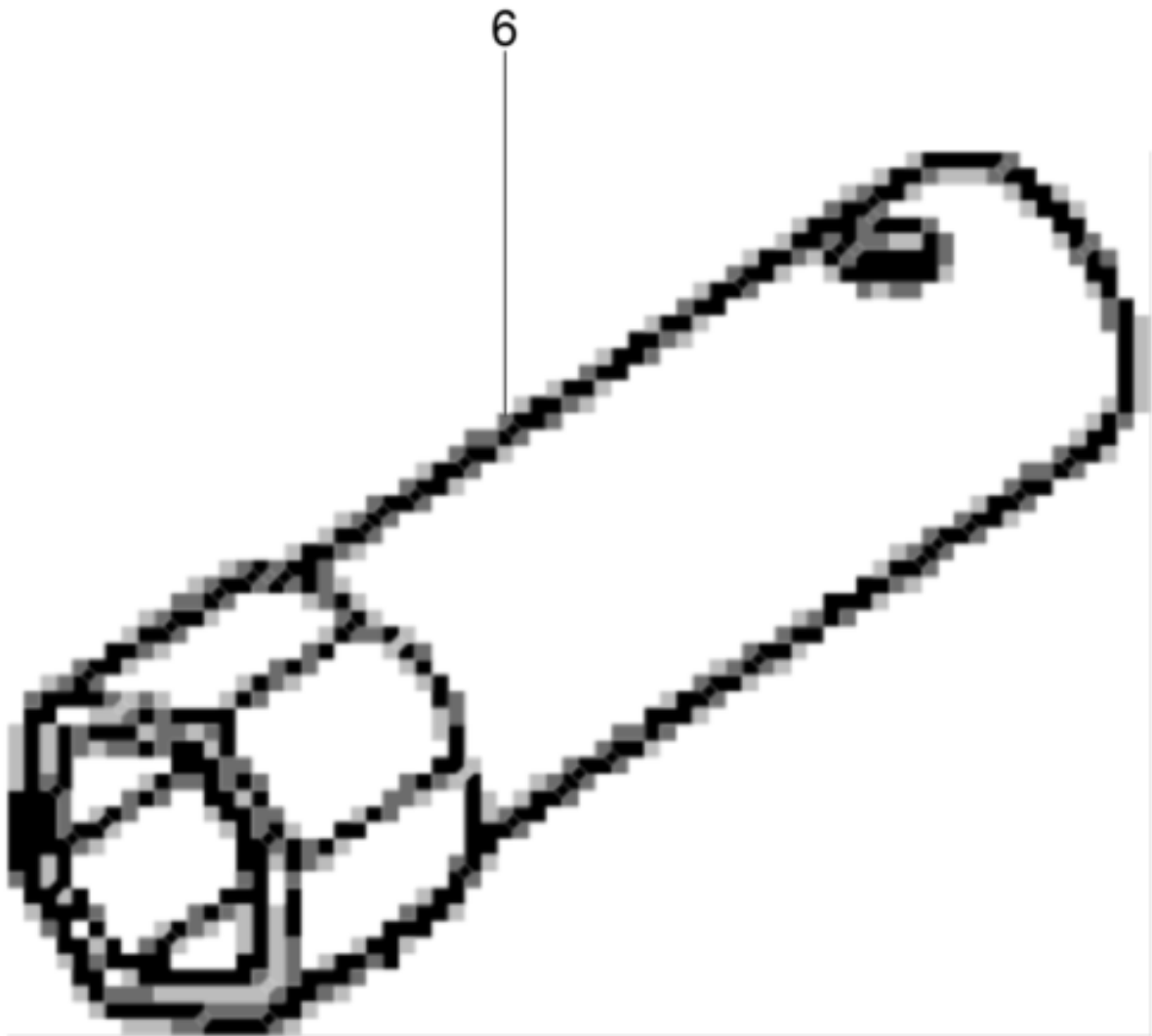

**BS50-4AS 11IN US****Werkzeug  
Tool  
Herramienta  
Outil**

Pos. Item	Artikel Nr. Item no.	Pc.	Unit	Beschreibung Descripción	Description Description	Abm. Dim.	Norm Standard
						Drehmoment Torque	Schmierstoff Lubricant
6	5100031004	1	pc	Schlüssel Llave	Key Clé		



Notiz  
Note  
Observaciones  
Note

**BS50-4AS 11IN US**







**WACKER  
NEUSON**

