



**WACKER  
NEUSON**

Ersatzteilkatalog  
Spare parts catalog  
Catálogo de piezas de repuesto  
Catalogue de pièces de rechange

**Vibrationsstampfer  
Vibratory rammer  
Apsonadores vibratorios  
Pilonneuse vibrante**

# **BS50-2plus 11in**



Type	BS50-2plus 11in
Material Number	5100030596
Version	101
Language	de   en   es   fr



[www.wackerneuson.com](http://www.wackerneuson.com)

Copyright © 01.2024  
Wacker Neuson Produktion GmbH & Co. KG  
Printed in Germany.  
All rights reserved.

Ein Typenschild mit Typ, Artikelnummer, Version und Maschinen-Nummer ist an jedem Gerät angebracht. Die Daten von diesem Schild bitte notieren, damit sie auch bei Verlust oder Beschädigung des Schildes noch vorhanden sind. Der Typ, die Artikelnummer, die Versions-Nummer und die Maschinen-Nummer sind bei der Ersatzteilbestellung oder Nachfragen bezüglich Service-Informationen stets erforderlich.

Bei den in den Ersatzteillisten fettgedruckten Nummern handelt es sich um empfohlene Ersatzteile. Dies bedeutet, daß diese Teile bei normalen Anwendungsbedingungen natürlicher Abnutzung ausgesetzt sind und gelegentlich ersetzt oder überarbeitet werden müssen. Es wird geraten, diese Teile auf Lager bereit zu haben, um für Service-Arbeiten an diesem Gerät vorbereitet zu sein. Lagerbestände für diese und andere Teile, welche für ausgiebigere Reparaturarbeiten benötigt werden, können je nach Service-Gewohnheiten der einzelnen Kunden variieren.

Die Nummern meines Gerätes sind:

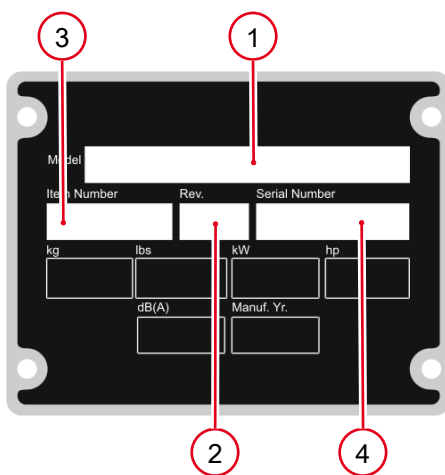

1. Typ
2. Version
3. Artikel-Nr.
4. Maschinen-Nr.

**Umrechnungstabelle**

Volumeneinheit	
1 ml	0.034 US fl.oz.
1 l	0.260 gal
Längeneinheit	
1 mm	0.039 in
1 m	3.280 ft
Gewicht	
1 kg	2.200 lbs
1 g	0.035 oz
Geschwindigkeit	
1 km/h	0.620 mph
Drehmoment	
1 Nm	0.740 ft.lbs

A nameplate listing the Model Number, Item Number, Revision, and Serial Number is attached to each unit. Please record the information found on this plate so it will be available should the nameplate become lost or damaged. When ordering parts or requesting service information, you will always be asked to specify the model, item number, revision number, and serial number of the unit.

Part Numbers appearing in boldface type are recommended spare parts. This means that these parts are subject to wear under normal operating conditions and may require periodic service or replacement. It is recommended that these items be stocked to meet the expected service requirements of this model. Actual stocking quantities of these and other parts used in more extensive repairs will depend on the service practices of each customer.

My machine's numbers are:



- 1. Model
- 2. Revision
- 3. Item No.
- 4. Serial No.

**Conversion table**

Volume unit	
1 ml	0.034 US fl.oz.
1 l	0.260 gal
Unit of length	
1 mm	0.039 in
1 m	3.280 ft
Weight	
1 kg	2.200 lbs
1 g	0.035 oz
Speed	
1 km/h	0.620 mph
Torque	
1 Nm	0.740 ft.lbs

Una placa de identificación con el modelo, número de referencia, nivel de revisión y número de serie ha sido añadida en cada máquina. Favor de anotar los datos en la placa en caso de que la placa de identificación sea destruida o perdida. En todos los pedidos para repuestos necesita siempre el modelo, el número de referencia, el nivel de revisión y el número de serie de la máquina en cuestión.

Los números de partes en negritas en las Listas Ilustradas de Partes son los repuestos recomendados, esto quiere decir que estas partes se desgastarán bajo circunstancias de funcionamiento normales y pueden requerir servicio periódico o su reemplazo. Se recomienda que el cliente mantenga un abastecimiento adecuado de estas partes para poder satisfacer la demanda requerida por el servicio a la máquina. La cantidad de repuestos que el cliente necesitará para reparaciones dependerá de la póliza de servicio de cada cliente.

Los números de mi máquina son:

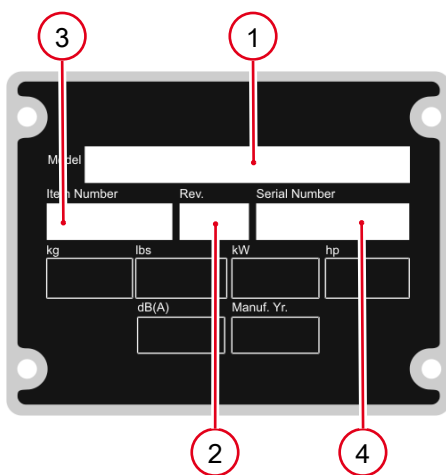

1. Modelo
2. Nivel de revisión
3. Número de referencia
4. Número de Serie

**Tabla de conversión**

Unidad de volumen	
1 ml	0.034 US fl.oz.
1 l	0.260 gal
Unidad de longitud	
1 mm	0.039 in
1 m	3.280 ft
Peso	
1 kg	2.200 lbs
1 g	0.035 oz
Velocidad	
1 km/h	0.620 mph
Par de apriete	
1 Nm	0.740 ft.lbs

Stampfer Rammer Apisonador Pilonneuse .....	8
--	---

Führungsbügel Kpl. Guiding frame cpl. Manillar cpl. Étrier cpl. ....	10
---	----

Gasregler Kpl. Throttle control cpl. Acelerador cpl. Commande des gaz cpl. ....	12
--	----

Führungszylinder Kpl. Guiding cylinder cpl. Cilindro de guía cpl. Cylindre de guidage cpl. ....	14
--	----

Kurbeltrieb Kpl. Crank gear cpl. Mecanismo de manivela cpl. Arbre manivelle cpl. ....	16
--	----

Fliehkraftglocke Kpl. Clutch drum cpl. Campana centrífuga cpl. Canter embrayage cpl. ....	18
--	----

Motor Anbauteile Mounting parts engine Pie de fijación motor Pièces d'adaption moteur .....	20
--	----

Standardmotor Standard engine Motor standard Moteur standard .....	22
---	----

Vergaser Kpl. Carburetor cpl. Carburador cpl. Carburateur cpl. ....	26
--	----

Vergaser Carburetor Carburador Carburateur .....	28
---	----

Vergaser HDA-356 Carburetor hda-356 Carburador hda-356 Carburateur hda-356 .....	32
---	----

Reversierstarter Recoil starter Starter reversible Démarreur réversible .....	36
--	----

Auspuff Kpl.  
Muffler cpl.  
Escape cpl.  
Échappement cpl. .... 38

Luftfilter Kpl.  
Air filter cpl.  
Filtro de aire cpl.  
Filtre à air cpl. .... 40

Stampfeinsatz Kpl.  
Ramming shoe cpl.  
Pisón cpl.  
Tête de frappe cpl. .... 42

Ölpumpe Kpl.  
Oil pump cpl.  
Bomba de aceite cpl.  
Pompe à huile cpl. .... 44

Aufkleber  
Labels  
Calcomania  
Autocollant ..... 46

Wartungspaket  
Maintenance kit  
Juego para mantenimiento  
Jeu d'entretien ..... 48

Zubehör  
Accessories  
Accesorios  
Accessoires

Öltankdeckel Abschiessbar  
Oil tank cap lockable  
Tapa de tanque cerrable  
Couvercle du réservoir fermant ..... 50

Rädersatz  
Wheel kit  
Juego de rueda  
Jeu de roue ..... 52



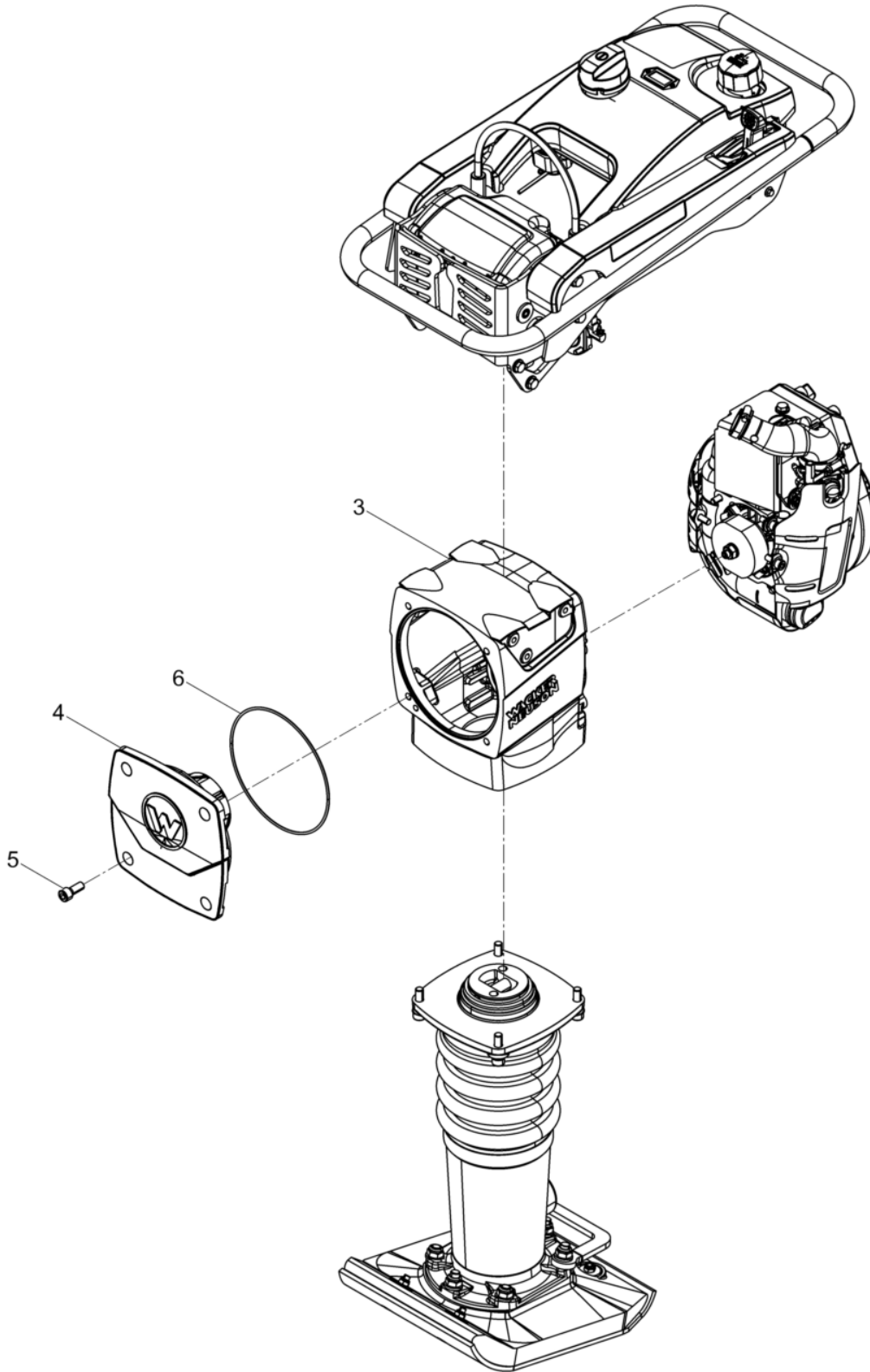



Pos. Item	Artikel Nr. Item no.	Pc.	Unit	Beschreibung Descripción	Description Description	Abm. Dim.	Norm Standard
						Drehmoment Torque	Schmierstoff Lubricant
3	5100045479	1	pc	Kurbelgehäuse Cárter	Crankcase Carter		
4	5100032132	1	pc	Kurbelgehäusedeckel Tapa del cárter	Crankcase cover Couvercle de carter		
5	5000011535	4	pc	Zylinderschraube Tornillo cilíndrico	Cheese head screw Vis à tête cylindrique		
6	5100033181	1	pc	O-Ring Anillo-o	O-ring Bague-o		
24	5100032274	1	pc	Ersatz-Transportrolle Juego-rodillo de transporte	Roller kit Jeu de rouleau de transport		

Führungsbügel Kpl.  
Guiding frame cpl.  
Manillar cpl.  
Étrier cpl.

BS50-2plus 11in

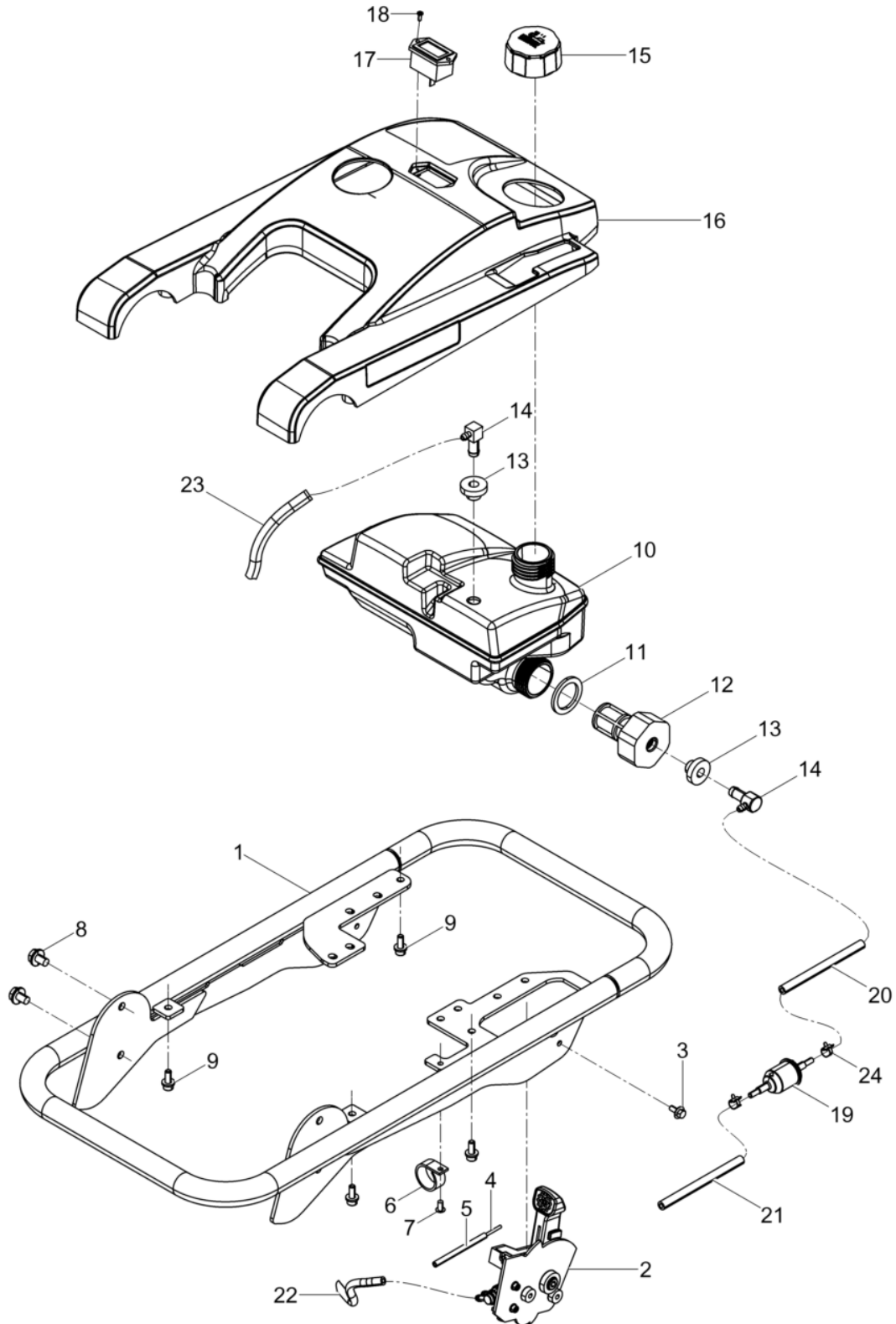

Pos. Item	Artikel Nr. Item no.	Pc.	Unit	Beschreibung Descripción	Description Description	Abm. Dim.	Norm Standard
						Drehmoment Torque	Schmierstoff Lubricant
1	5100028600	1	pc	Führungsbügel Manija	Guide handle Poignée		
2	5100030465	1	pc	Gasregler Kpl. Acelerador cpl.	Throttle control cpl. Commande des gaz cpl.		
3	5000155845	2	pc	Sechskantschraube Tornillo hexagonal	Hexagonal head cap screw Boulon à tête hexagonale	M5 x 12	
4	5100032225	1	pc	Bowdenzugseil Cable bowden	Bowden cable Câble bowden		
5	5100032226	1	pc	Bowdenzughülle Cable bowden exterior	Outer bowden cable Câble bowden extérieur		
6	5000155562	1	pc	Befestigung Clip	Clip Clip		
7	5100035983	1	pc	Blindniet Remache ciego	Blind rivet Rivet dobturation		
8	5100027071	4	pc	Schraube Tornillo	Screw Vis		
9	5000160861	8	pc	Schraube Tornillo	Screw Vis	M6 x 16	
10	5100030302	1	pc	Kraftstofftank Tanque de combustible	Fuel tank Réservoir de carburant		
11	5000086312	1	pc	Dichtungsring Anillo sellador	Ring seal Rondelle à étancher		
12	5100028935	1	pc	Wasserfilter Filtro de agua	Water filter Filtre à eau		
13	5100032258	2	pc	Buchse Buje	Bush Boîte		
14	5100066546	2	pc	Anschlussnippel Boquilla de conexión	Connecting nipple Raccord fileté		
15	5100030407	1	pc	Kraftstofftankdeckel Tapa de tanque	Tank cap Couvercle du réservoir		
16	5100031423	1	pc	Abdeckung Cubierta	Covering Couverture		
17	5100034578	1	pc	Betriebsstundenzähler Contador de las horas	Working hour meter Compteur d'heures		
18	5000209453	2	pc	PT-Schraube Tornillo	Screw Vis		
19	5100068032	1	pc	Kraftstofffilter Filtro de combustible	Fuel filter Filtre à carburant		
20	5100034651	1	pc	Kraftstoffschlauch Manguera de combustible	Fuel hose Tuyau à essence		
21	5100034652	1	pc	Kraftstoffschlauch Manguera de combustible	Fuel hose Tuyau à essence		
22	5100034653	1	pc	Kraftstoffschlauch Manguera de combustible	Fuel hose Tuyau à essence		
23	5100034654	1	pc	Kraftstoffschlauch Manguera de combustible	Fuel hose Tuyau à essence		
24	5000171698	2	pc	Schelle Abrazadera	Clamp Agrafe	3/8in	

Gasregler Kpl.  
Throttle control cpl.  
Acelerador cpl.  
Commande des gaz cpl.

BS50-2plus 11in

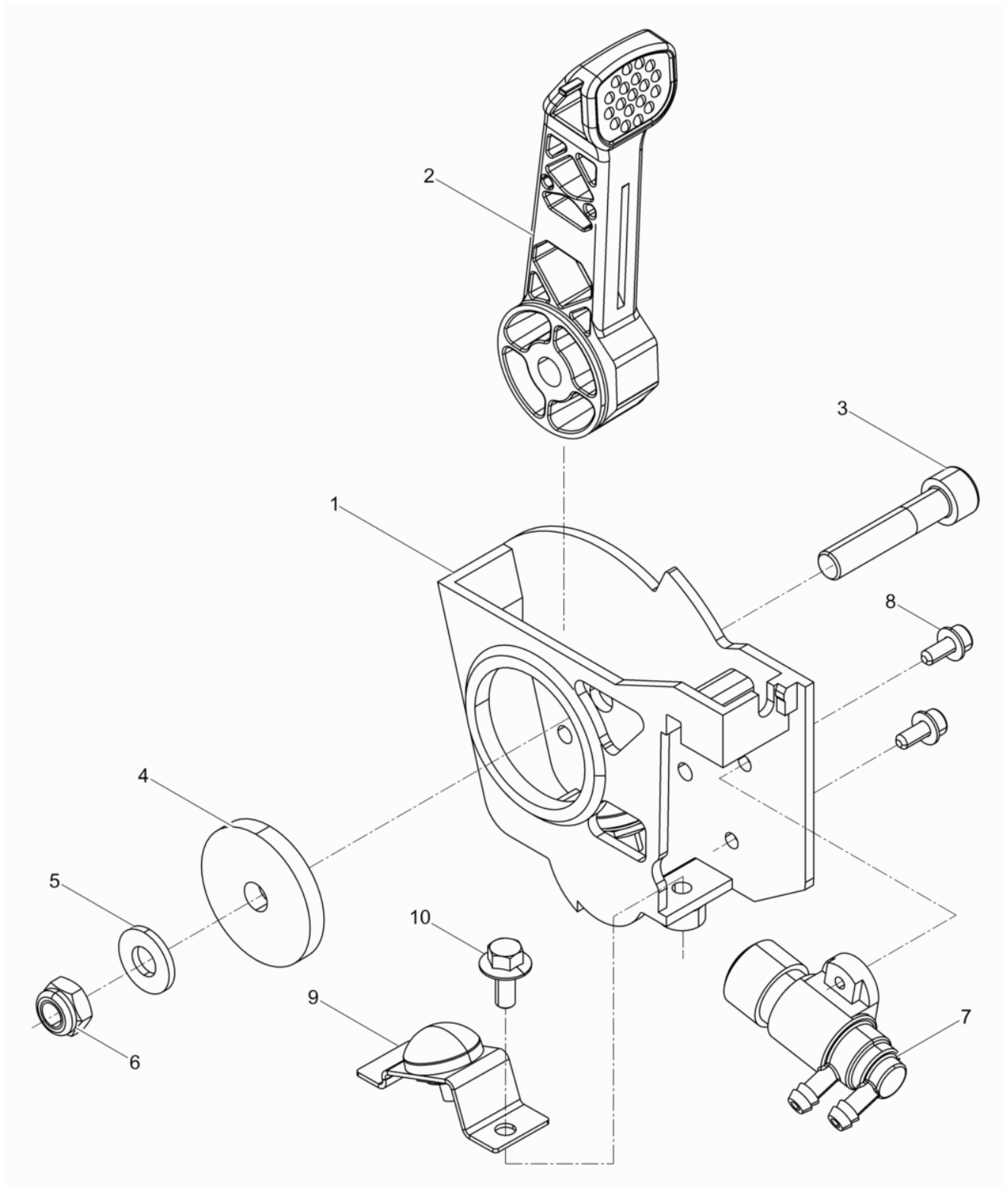

Pos. Item	Artikel Nr. Item no.	Pc.	Unit	Beschreibung Descripción	Description Description	Abm. Dim.	Norm Standard
						Drehmoment Torque	Schmierstoff Lubricant
1	5100032228	1	pc	Gasreglerkonsole Soporte	Bracket Support		
2	5100032229	1	pc	Gashebel Acelerador	Throttle lever Manette de gaz		
3	5000011539	1	pc	Zylinderschraube Tornillo cilíndrico	Cheese head screw Vis à tête cylindrique	M8 x 40 25Nm/18ft.lbs	ISO4762
4	5000105194	1	pc	Scheibe Arandela	Washer Rondelle	M8 x 1,5in	
5	5000033198	1	pc	Spannscheibe Arandela elástica	Lockwasher Rondelle de ressort		DIN6796
6	5000010367	1	pc	Sechskantmutter Tuerca hexagonal	Hexagon nut Écrou hexagonal		DIN985
7	5100032270	1	pc	Kraftstoffhahn Llave de combustible	Fuel cock Robinet d'essence		
8	5000165047	2	pc	Zylinderschraube Tornillo cilíndrico	Socket head cap screw Vis à tête cylindrique	M4 x 10	
9	5100032271	1	pc	Stopschalter Interruptor de stop	Stop switch Interrupteur		
10	5000155845	1	pc	Sechskantschraube Tornillo hexagonal	Hexagonal head cap screw Boulon à tête hexagonale	M5 x 12	

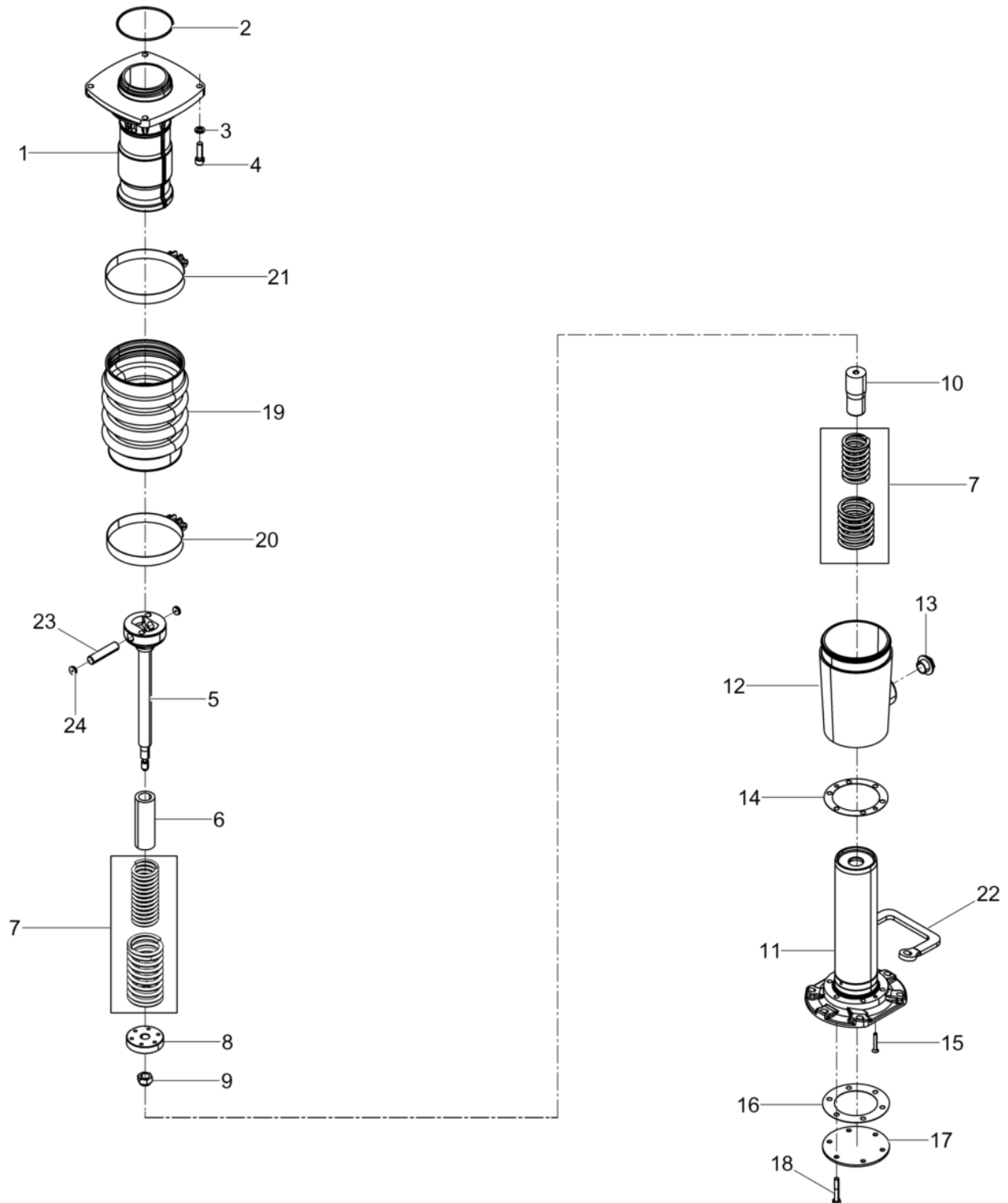

Pos. Item	Artikel Nr. Item no.	Pc.	Unit	Beschreibung Descripción	Description Description	Abm. Dim.	Norm Standard
						Drehmoment Torque	Schmierstoff Lubricant
1	5100038429	1	pc	Führungszylinder Cilindro de guía	Guide cylinder Cylindre de guidage		
2	5000031880	1	pc	O-Ring Anillo-o	O-ring Joint torique	96 x 3	
3	5000010644	4	pc	Federring Arandela elástica	Lock washer Rondelle de ressort	A10	DIN128
4	5000011533	4	pc	Zylinderschraube Tornillo cilíndrico	Cheese head screw Vis à tête cylindrique	M10 x 35 49Nm/36ft.lbs	ISO4762
5	5100038472	1	pc	Führungskolben Émbolo guía	Guide piston Piston de guidage		
6	5100032036	1	pc	Dämpfungbüchse Buje	Bushing Douille		
7	5100071907	2	pc	Federsatz Juego de resorte	Spring set Jeu de ressort		
8	5100032038	1	pc	Kolbenführung Guía de pistón	Piston guide Guide de piston		
9	5000110196	1	pc	Sicherungsmutter Contratuercas	Lock nut Contre-écrou		
10	5100032039	1	pc	Dämpfungsstopfen Tapón amortiguador	Damper Bouchon amortisseur		
11	5100045300	1	pc	Federzylinder Cilindro de elástico	Spring cylinder Cylindre à ressort		
12	5100052097	1	pc	Schutzrohr Tubo de protección	Protective pipe Tube de protection		
13	5100033182	1	pc	Ölstandsauge Indicador de aceite	Sight glass Indicateur		
14	5100032110	1	pc	Dichtung Junta	Gasket Joint		
15	5000155017	2	pc	Senkschraube Tornillo avellanado	Countersunk screw Vis à tête conique	M6 x 40	ISO10642
16	5100032111	1	pc	Federzylinderdichtung Junta	Gasket Joint		
17	5100031608	1	pc	Deckel Tapa	Cover Couvercle		
18	5000011343	6	pc	Sechskantschraube Tornillo hexagonal	Hexagonal head cap screw Vis à tête hexagonale	M8 x 50 25Nm/18ft.lbs	DIN931
19	5100032112	1	pc	Faltenbalg Fuelle acordeón	Bellows Soufflet		
20	5000110537	1	pc	Schelle Abrazadera	Clamp Agrafe	5,75in ID	
21	5000110528	1	pc	Schelle Abrazadera	Clamp Agrafe	5,25in ID	
22	5100031620	1	pc	Tragegriff Mango	Handle Poignée		
23	5100032026	1	pc	Kolbenbolzen Pasador de pistón	Piston pin Axe de piston		
24	5100058422	2	pc	Kolbensicherung Tapón	Plug Bouchon		

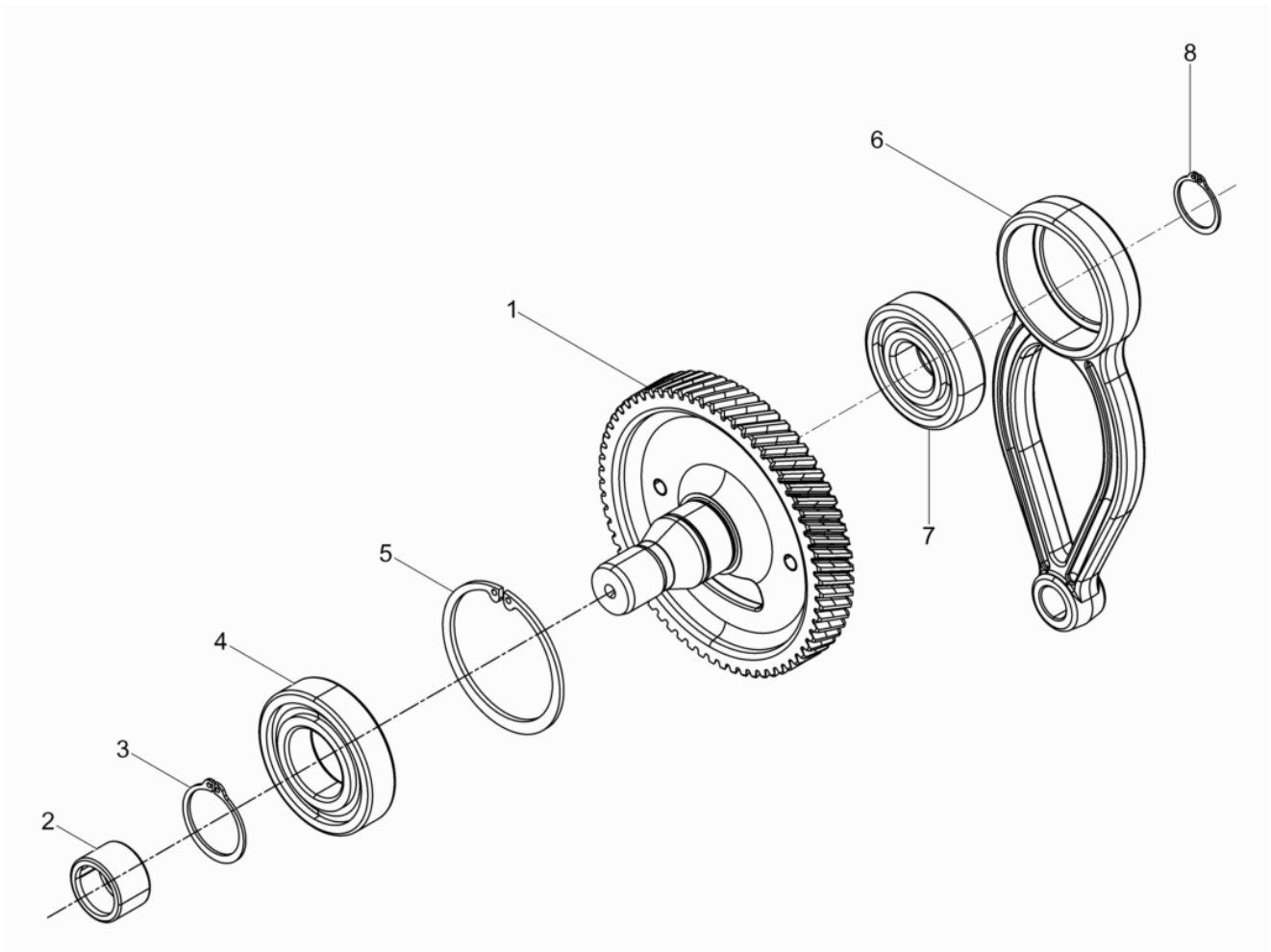



Pos. Item	Artikel Nr. Item no.	Pc.	Unit	Beschreibung Descripción	Description Description	Abm. Dim.	Norm Standard
						Drehmoment Torque	Schmierstoff Lubricant
1	5100037296	1	pc	Kurbeltrieb Mecanismo de manivelle	Crank gear Arbre manivelle		
2	5000072061	1	pc	Nadellager Rodamiento de agujas	Needle bearing Roulement à aiguilles		
3	5002003022	1	pc	Sicherungsring Anillo de retención	Retaining ring Bague d'arrêt	35 x 1,5	DIN471
4	5002003021	1	pc	Rillenkugellager Rodamiento de bolas	Grooved ball bearing Roulement à billes		
5	5002003023	1	pc	Sicherungsring Anillo de retención	Retaining ring Bague d'arrêt	72 x 2,5	DIN472
6	5100037875	1	pc	Pleuel Biela	Connecting rod Bielle		
7	5000045190	1	pc	Rillenkugellager Rodamiento de bolas	Grooved ball bearing Roulement à billes		
8	5002001041	1	pc	Sicherungsring Anillo de retención	Retaining ring Bague d'arrêt	25 x 1,2	DIN471

Fliehkraftglocke Kpl.  
Clutch drum cpl.  
Campana centrifuga cpl.  
Canter embrayage cpl.

BS50-2plus 11in

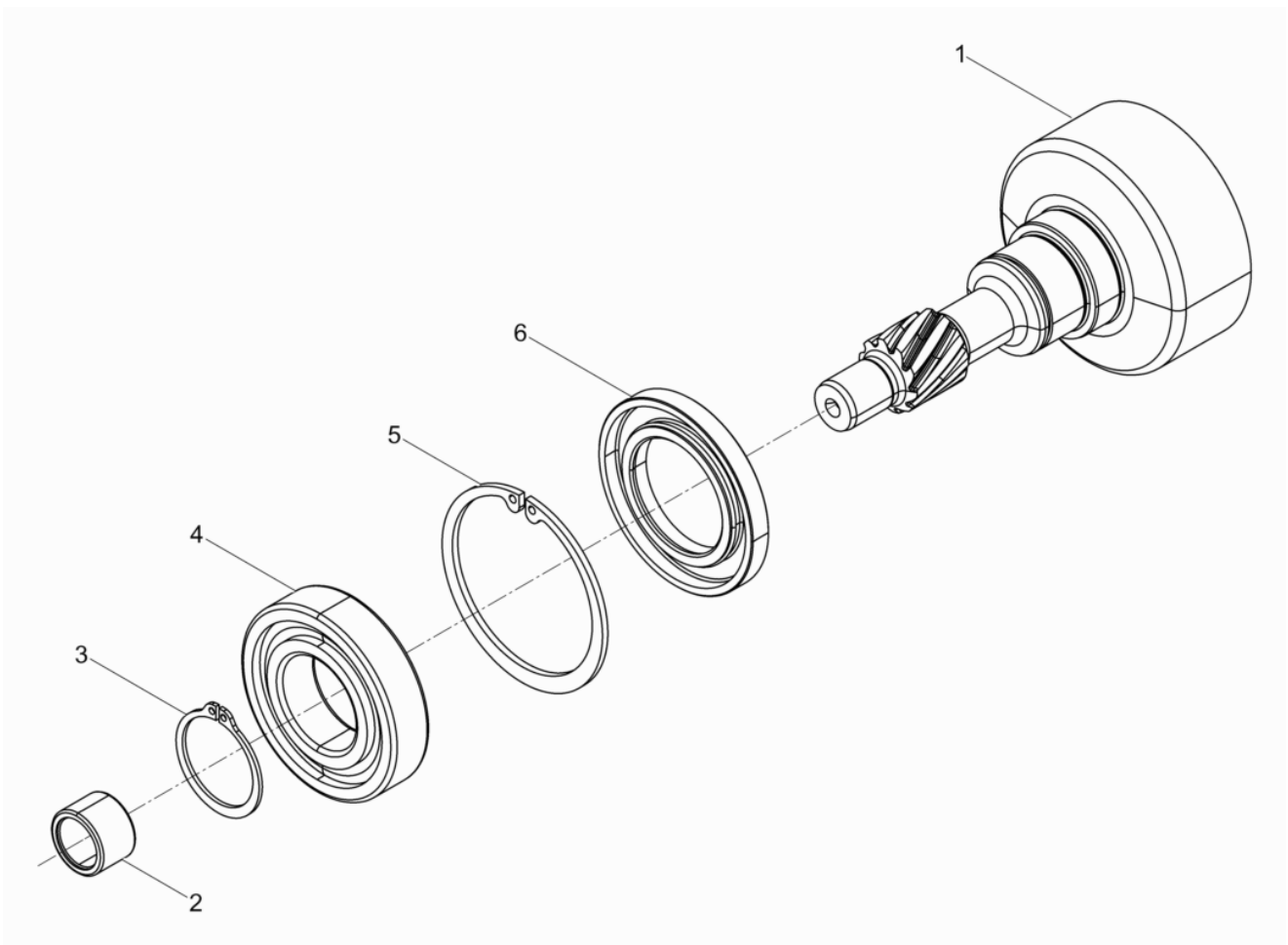

Pos. Item	Artikel Nr. Item no.	Pc.	Unit	Beschreibung Descripción	Description Description	Abm. Dim.	Norm Standard
						Drehmoment Torque	Schmierstoff Lubricant
1	5100038030	1	pc	Fliehkraftglocke Campana centrifuga	Clutch drum Canter embrayage		
2	5000039020	1	pc	Nadelhülse Rodamiento de agujas	Needle bearing Roulement à aiguilles		
3	5002003022	1	pc	Sicherungsring Anillo de retención	Retaining ring Bague d'arrêt	35 x 1,5	DIN471
4	5002003021	1	pc	Rillenkugellager Rodamiento de bolas	Grooved ball bearing Roulement à billes		
5	5002003023	1	pc	Sicherungsring Anillo de retención	Retaining ring Bague d'arrêt	72 x 2,5	DIN472
6	5000039050	1	pc	Wellendichtring Sello del eje	Shaft seal Bague d'étanchéité		

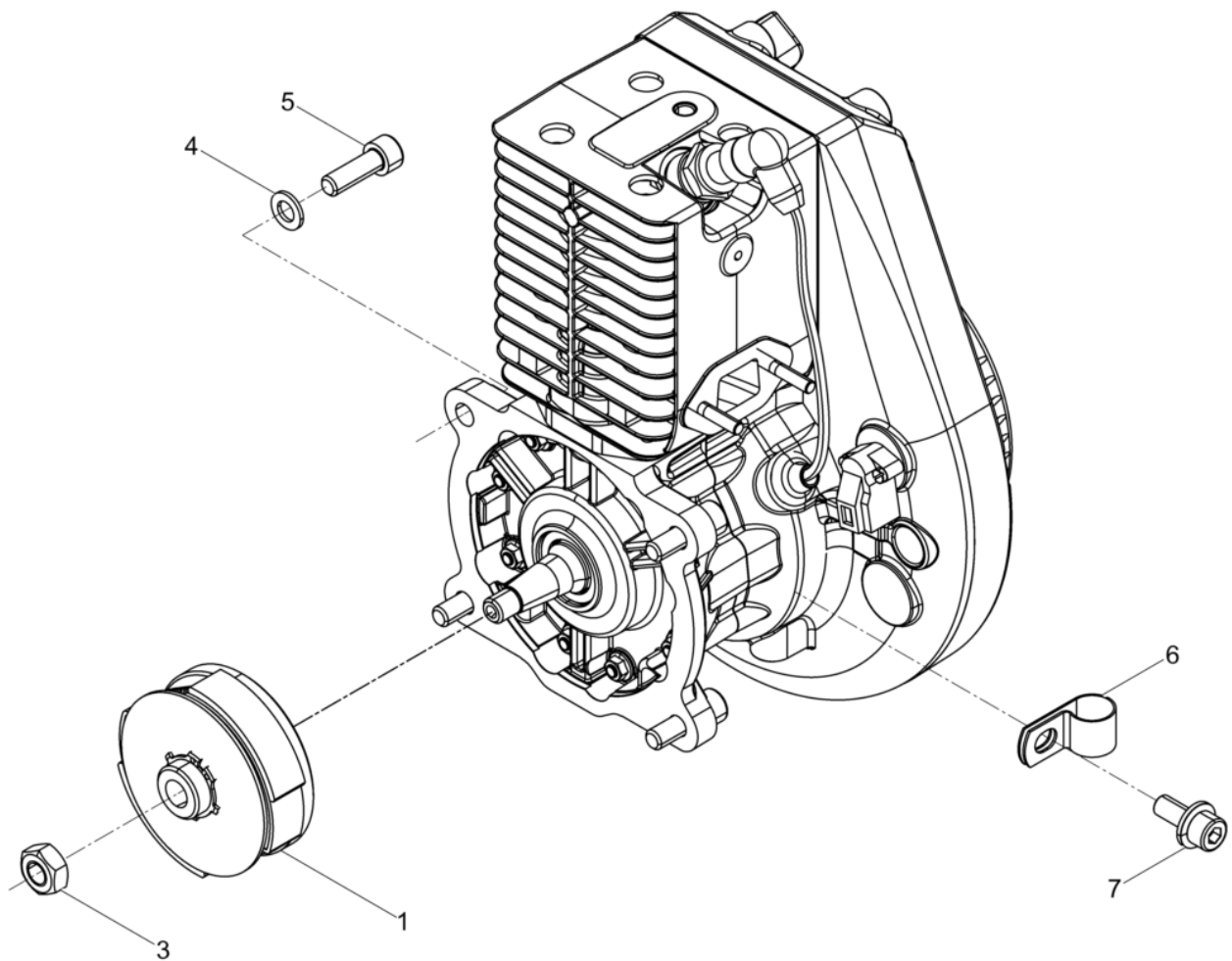

Pos. Item	Artikel Nr. Item no.	Pc.	Unit	Beschreibung Descripción	Description Description	Abm. Dim.	Norm Standard
						Drehmoment Torque	Schmierstoff Lubricant
1	5100045607	1	pc	Fliehkraftkupplung Embrague centrifugo	Centrifugal clutch Embrayage centrifuge		
3	5000010883	1	pc	Sechskantmutter Tuerca hexagonal	Hexagon nut Écrou hexagonal		
4	5000010622	4	pc	Scheibe Arandela	Flat washer Rondelle		
5	5000151559	4	pc	Zylinderschraube Tornillo cilíndrico	Cheese head screw Vis à tête cylindrique	M8 x 25 27Nm/20ft.lbs	ISO4762
6	5000156954	1	pc	Schlauchschelle Abrazaderas de manguera	Hose clamp Agrafe de tuyau	1/4in	
7	5000177452	1	pc	Schraube Tornillo	Screw Vis		

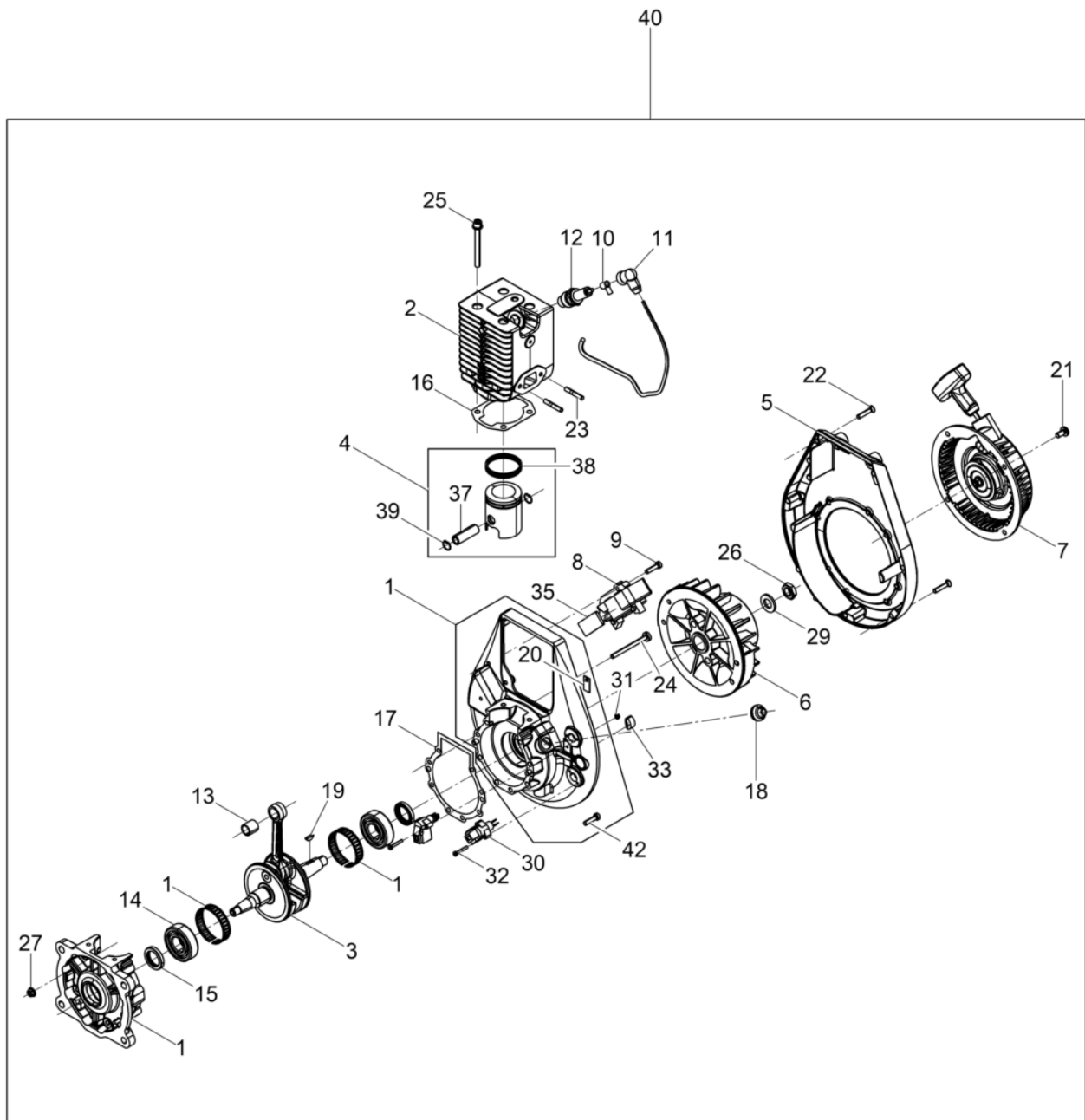

Pos. Item	Artikel Nr. Item no.	Pc.	Unit	Beschreibung Descripción	Description Description	Abm. Dim.	Norm Standard
						Drehmoment Torque	Schmierstoff Lubricant
1	5100009983	1	pc	Kurbelgehäuse Kpl. Cárter cpl.	Crankcase cpl. Carter cpl.		
2	5000213076	1	pc	Zylinder Cilindro	Cylinder Cylindre		
3	5100021110	1	pc	Kurbelwelle Kpl. Cigüeñal cpl.	Crankshaft cpl. Vilebrequin cpl.		
4	5000115324	1	pc	Kolben Pistón	Piston Piston		
5	5000105067	1	pc	Gebläsedeckel Tapa de ventilador	Fan hood Couvercle du sys. de vent.		
6	5000045041	1	pc	Lüfterrad Ventilador	Fan Ventilateur		
7	5000064446	1	pc	Reversierstarter Kpl. Starter reversible cpl.	Recoil starter cpl. Démarrreur réversible cpl.		
8	5000181216	1	pc	Zündanlage Instalación de encendido	Ignition module Installation dallumage		
9	5100049413	3	pc	Schraube Tornillo	Screw Vis		
10	5000153124	1	pc	Zündkerzenstecker Capuchón de bujía	Spark plug (terminal) cap Capuchon de bougie		
11	5000153125	1	pc	Zündkerzenstecker Capuchón de bujía	Spark plug (terminal) cap Capuchon de bougie		
12	5000172332	1	pc	Zündkerze Bujía	Spark plug Bougie		
13	5000034835	1	pc	Nadelkranz Rodamiento de agujas	Needle bearing Roulement à aiguilles		
14	5100065070	2	pc	Rillenkugellager Rodamiento de bolas	Grooved ball bearing Roulement à billes		
15	5100006052	2	pc	Wellendichtring Sello del eje	Shaft seal Bague d'étanchéité		
16	5100025323	1	pc	Zylinderdichtung Junta del cilindro	Cylinder gasket Joint de cylindre		
17	5100025322	1	pc	Kurbelgehäusedichtung Junta	Gasket Joint		
18	5100060760	1	pc	Kabeldurchführung Conducto de cable	Cable passage Passage de câble		
19	5000010388	1	pc	Scheibenfeder Chaveta woodruff	Woodruff key Clavette woodruff	3 x 5	DIN6888
20	5000045906	2	pc	Halter Retenedor	Retainer Arrêtoir		
21	5000153273	4	pc	Flachkopfschraube Tornillo de cabeza de cono achataado	Pan head screw Vis ber	M6 x 12	DIN85
22	5000153272	7	pc	Schraube Tornillo	Screw Vis	M5 x 25	DIN964
23	5100027617	2	pc	Stiftschraube Perno prisionero	Stud Boulon	M5x20	
24	5000215365	8	pc	Zylinderschraube Tornillo cilíndrico	Cheese head screw Vis à tête cylindrique	M 5x 60	
25	5000095917	4	pc	Zylinderschraube Tornillo cilíndrico	Cheese head screw Vis à tête cylindrique	M6 x 60	
26	5000045914	1	pc	Sechskantmutter Tuerca hexagonal	Hexagon nut Écrou hexagonal	M12 x 1,5	ISO8675
27	5000183750	8	pc	Sechskantmutter Tuerca hexagonal	Hexagon nut Écrou hexagonal		
29	5000010620	1	pc	Scheibe Arandela	Flat washer Rondelle	12	ISO7090

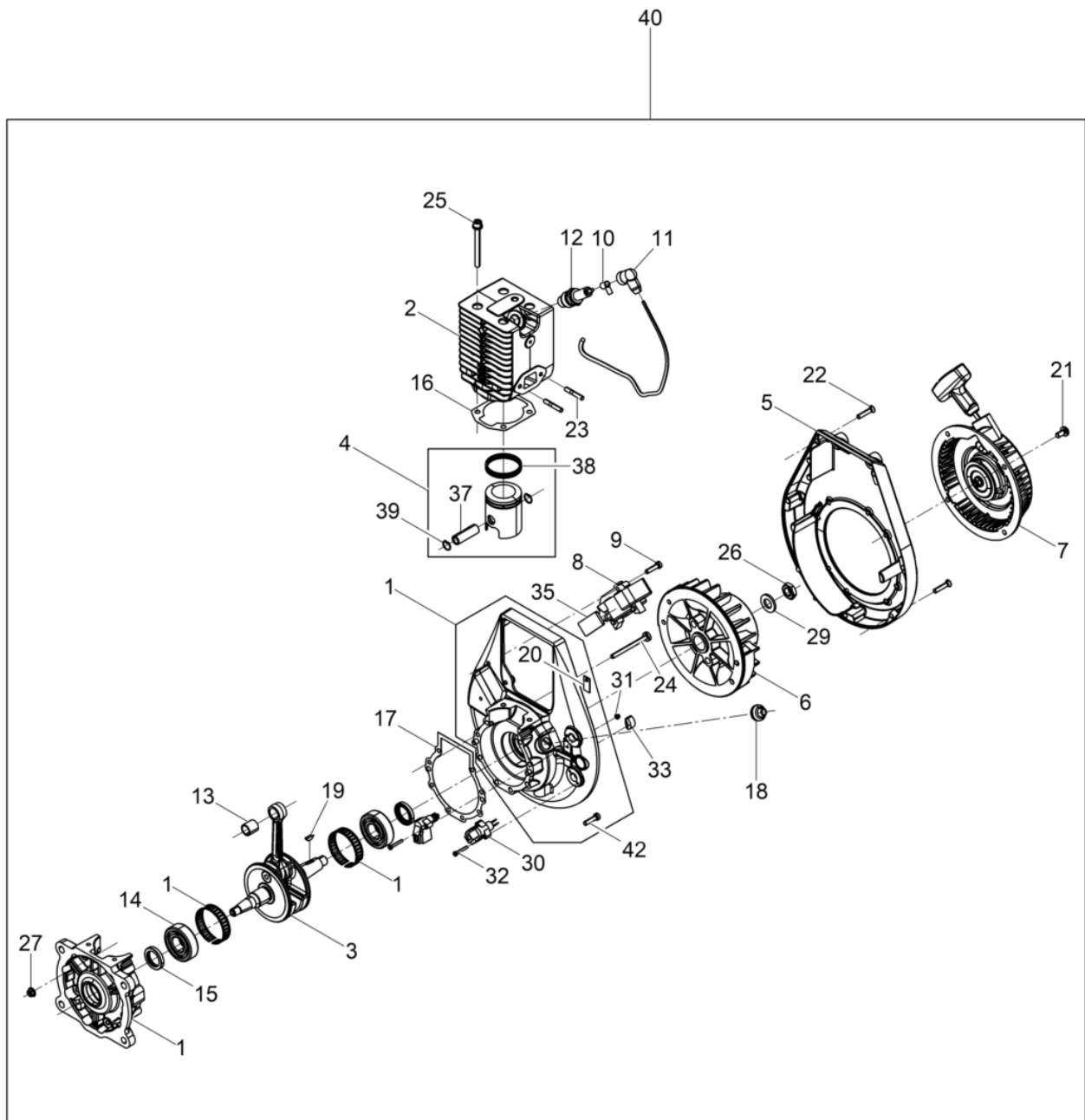



Pos. Item	Artikel Nr. Item no.	Pc.	Unit	Beschreibung Descripción	Description Description	Abm. Dim.	Norm Standard
						Drehmoment Torque	Schmierstoff Lubricant
30	5000080502	2	pc	Winkelstecker Terminal	Terminal post Borne d'attache		
31	5000102116	1	pc	Sechskantmutter Tuerca hexagonal	Hexagon nut Écrou hexagonal	M3	ISO10511
32	5000011730	4	pc	Zylinderschraube Tornillo cilindrico	Cheese head screw Vis à tête cylindrique	M3 x 20	ISO1207
33	5000049586	1	pc	Schutzkappe Capa de protección	Protective cap Chape de protection		
35	5000164990	1	pc	Schaumstoff Materia espumoso	Foam Mousse		
37	5000012199	1	pc	Kolbenbolzen Pasador de pistón	Piston pin Axe de piston		
38	5000045904	2	pc	Kolbenring Aro de pistón	Piston ring Segment de piston	45 x 1,5	DIN70910
39	5000012257	2	pc	Drahtsprengring Anillo de retención	Retaining ring Bague d'arrêt	A12	DIN73123
40	5100009684	1	pc	WM 80 Motor Wm 80 motor	Wm 80 engine Wm 80 moteur		
42	5100049413	3	pc	Schraube Tornillo	Screw Vis		

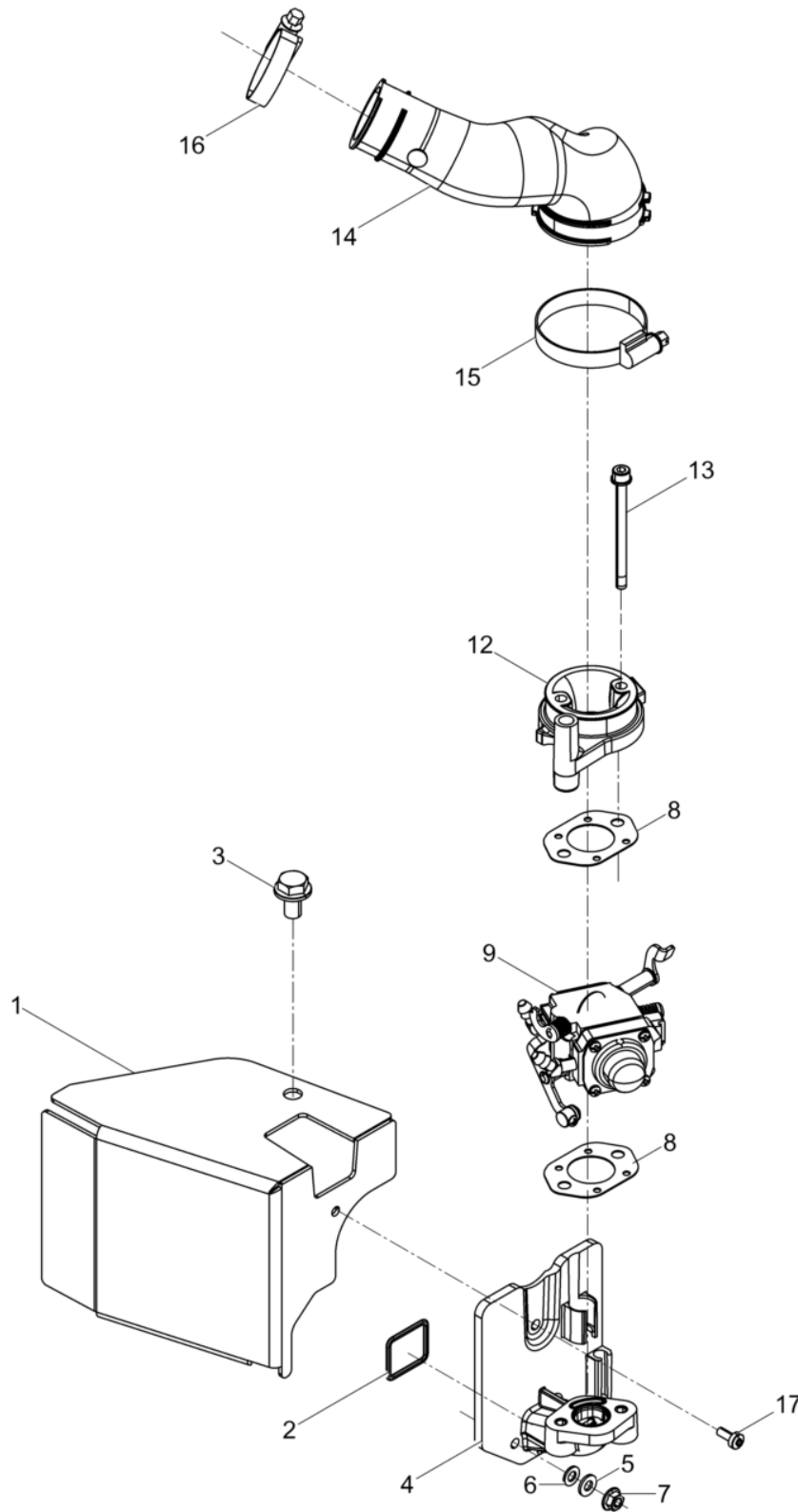

Pos. Item	Artikel Nr. Item no.	Pc.	Unit	Beschreibung Descripción	Description Description	Abm. Dim.	Norm Standard
						Drehmoment Torque	Schmierstoff Lubricant
1	5100059332	1	pc	Luftleitblech Chapa deflectora	Air duct plate Tôle d'aeration		
2	5100002961	1	pc	O-Ring Anillo-o	O-ring Bague-o	26x2	
3	5100027072	1	pc	Schraube Tornillo	Screw Vis		
4	5100048930	1	pc	Vergaserflansch Carburador brida	Carburetor flange Carburateur bride		
5	5000103212	2	pc	Scheibe Arandela	Washer Rondelle	5	DIN134
6	5000103211	2	pc	Spannscheibe Arandela elástica	Lockwasher Rondelle de ressort	5	DIN6796
7	5000183750	2	pc	Sechskantmutter Tuerca hexagonal	Hexagon nut Écrou hexagonal		
8	5000095774	2	pc	Dichtung Junta	Seal Joint		
9	5100061746	1	pc	Vergaser Carburador	Carburetor Carburateur		
12	5100032275	1	pc	Adapter Adaptador	Adaptor Adaptateur		
13	5100075649	2	pc	Kombi-Schraube M 5X 65 Tornillo m 5x 65	Screw m 5x 65 Vis m 5x 65		
14	5100032179	1	pc	Luftrohr Tubo de aire	Air tube Tube d'air		
15	5000078844	1	pc	Schelle Abrazadera	Clamp Agrafe	32-50	
16	5100033186	1	pc	Schelle Abrazadera	Clamp Agrafe		
17	5000222072	1	pc	Schraube Tornillo	Screw Vis	M 4x 10	

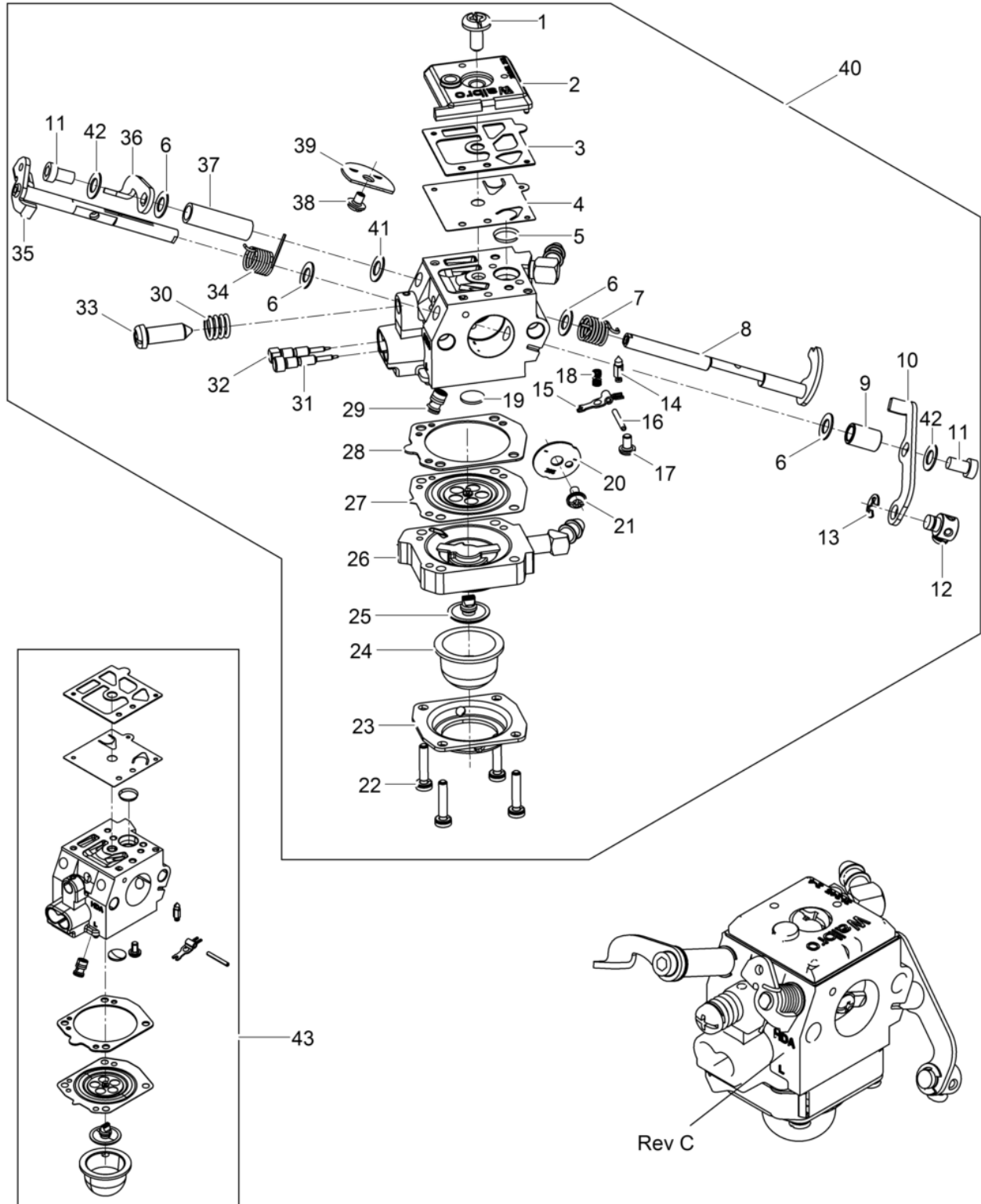

Pos. Item	Artikel Nr. Item no.	Pc.	Unit	Beschreibung Descripción	Description Description	Abm. Dim.	Norm Standard
						Drehmoment Torque	Schmierstoff Lubricant
1	5000182757	1	pc	Flachkopfschraube Tornillo de cabeza de cono achatado	Pan head screw Vis ber		
2	5000222013	1	pc	Deckel Cubierta	Cover Couvercle		
3	5000182759	1	pc	Dichtung Junta	Gasket Joint		
4	5000182760	1	pc	Membran Kpl. Diafragma compl.	Diaphragm cpl. Diafragma compl.		
5	5000182761	1	pc	Sieb Tamiz	Screen Tamis		
6	5000175300	4	pc	Scheibe Arandela	Washer Rondelle		
7	5000182762	1	pc	Feder Resorte	Spring Ressort		
8	5200008316	1	pc	Chokewelle Kpl. Eje estrangulador compl.	Choke shaft cpl. Arbre étrangleur compl.		
9	5000182764	1	pc	Abstandsstück Espaciador	Spacer Entretoise		
10	5000182765	1	pc	Gashebel Palanca de regulador	Throttle lever Lever des gaz		
11	5100028370	2	pc	Zylinderschraube Tornillo hueco	Socket head screw Vis à six-pans creux		
12	5000183351	1	pc	Drehung Unión giratoria	Swivel Pivot		
13	5000182768	1	pc	Sicherungsring Anillo de retención	Retaining ring Bague d'arrêt		
14	5000182769	1	pc	Einlaßventil Válvula de admisión	Inlet valve Soupape d'admission		
15	5000182770	1	pc	Hebel Palanca	Lever Lever		
16	5000182771	1	pc	Stift Pasador	Pin Goupille		
17	5000222015	1	pc	Schraube Tornillo	Screw Vis		
18	5000175306	1	pc	Feder Resorte	Spring Ressort		
19	5000182772	1	pc	Stopfen Tapón	Plug Bouchon		
20	5000183357	1	pc	Gasreglerklappe Válvula de estrangulación	Throttle valve Étrangleur		
21	5000175305	1	pc	Schraube Tornillo	Screw Vis		
22	5000175307	4	pc	Schraube Tornillo	Screw Vis		
23	5000182773	1	pc	Deckel Tapa	Cover Couvercle		
24	5000182774	1	pc	Birne Bombilla	Bulb Ampoule		
25	5000180019	1	pc	Ventil Válvula	Valve Soupape		
26	5000182775	1	pc	Entlüftungsventil Kpl. Purgador de aire compl.	Air purge cpl. Robinet purgeur d'air compl.		
27	5000182776	1	pc	Membran Kpl. Diafragma compl.	Diaphragm cpl. Diafragma compl.		
28	5000182777	1	pc	Dichtung Junta	Gasket Joint		



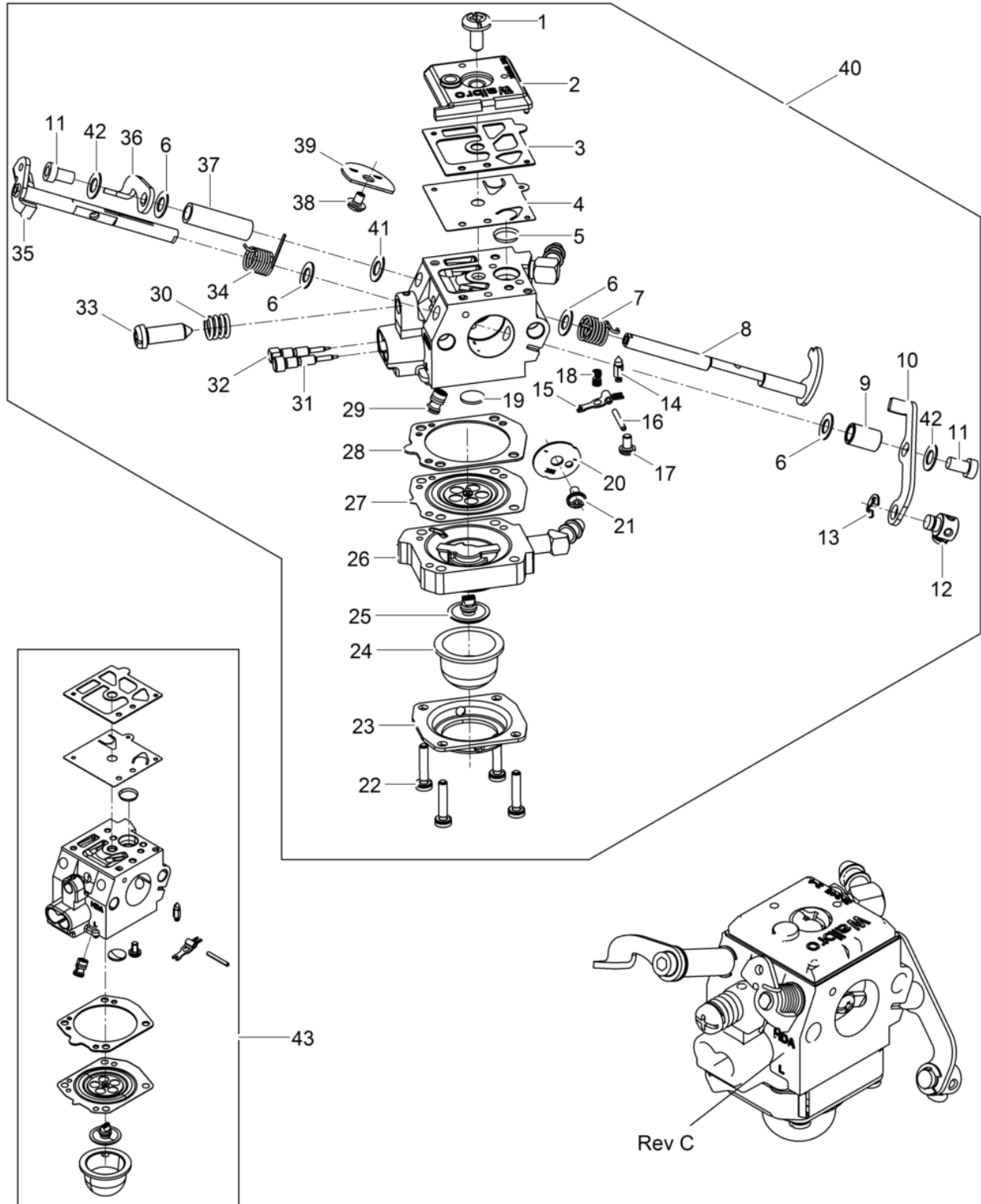

Pos. Item	Artikel Nr. Item no.	Pc.	Unit	Beschreibung Descripción	Description Description	Abm. Dim.	Norm Standard
						Drehmoment Torque	Schmierstoff Lubricant
29	5000182784	1	pc	Düse Tobera	Nozzle Ajutage		
30	5000182778	1	pc	Feder Resorte	Spring Ressort		
31	5000175319	1	pc	Nadel Aguja	Needle Aiguille		
32	5000182779	1	pc	Nadelventil Válvula de aguja	Needle valve Soupape à pointeau		
33	5000175310	1	pc	Leerlauf Einstellschraube Tornillo de velocidad de ralenti	Idle speed screw Vis de régime de ralenti		
34	5100028371	1	pc	Feder Resorte	Spring Ressort		
35	5000182781	1	pc	Gasreglerwelle Kpl. Eje de mariposa compl.	Throttle shaft cpl. Arbre des gaz compl.		
36	5000182782	1	pc	Chokehebel Palanca estrangulador	Choke lever Levier - étrangleur		
37	5100028373	1	pc	Hülse Manguito	Sleeve Douille		
38	5000175315	1	pc	Schraube Tornillo	Screw Vis		
39	5000182310	1	pc	Drosselventil Válvula estranguladora	Choke valve Soupape d'étranglement	17mm OD	
40	5000183841	1	pc	Walbro Vergaser Carburador de walbro	Walbro carburetor Walbro carburateur	11,10mm	
41	5100028374	1	pc	Scheibe Arandela	Washer Rondelle	0,30 ID x 0,19	
42	5100028375	2	pc	Scheibe Arandela	Washer Rondelle		
43	5000171010	1	pc	Vergaserwartungssatz Juego de reparación del carburador	Carburetor repair kit Jeu d'entretien du carburateur		

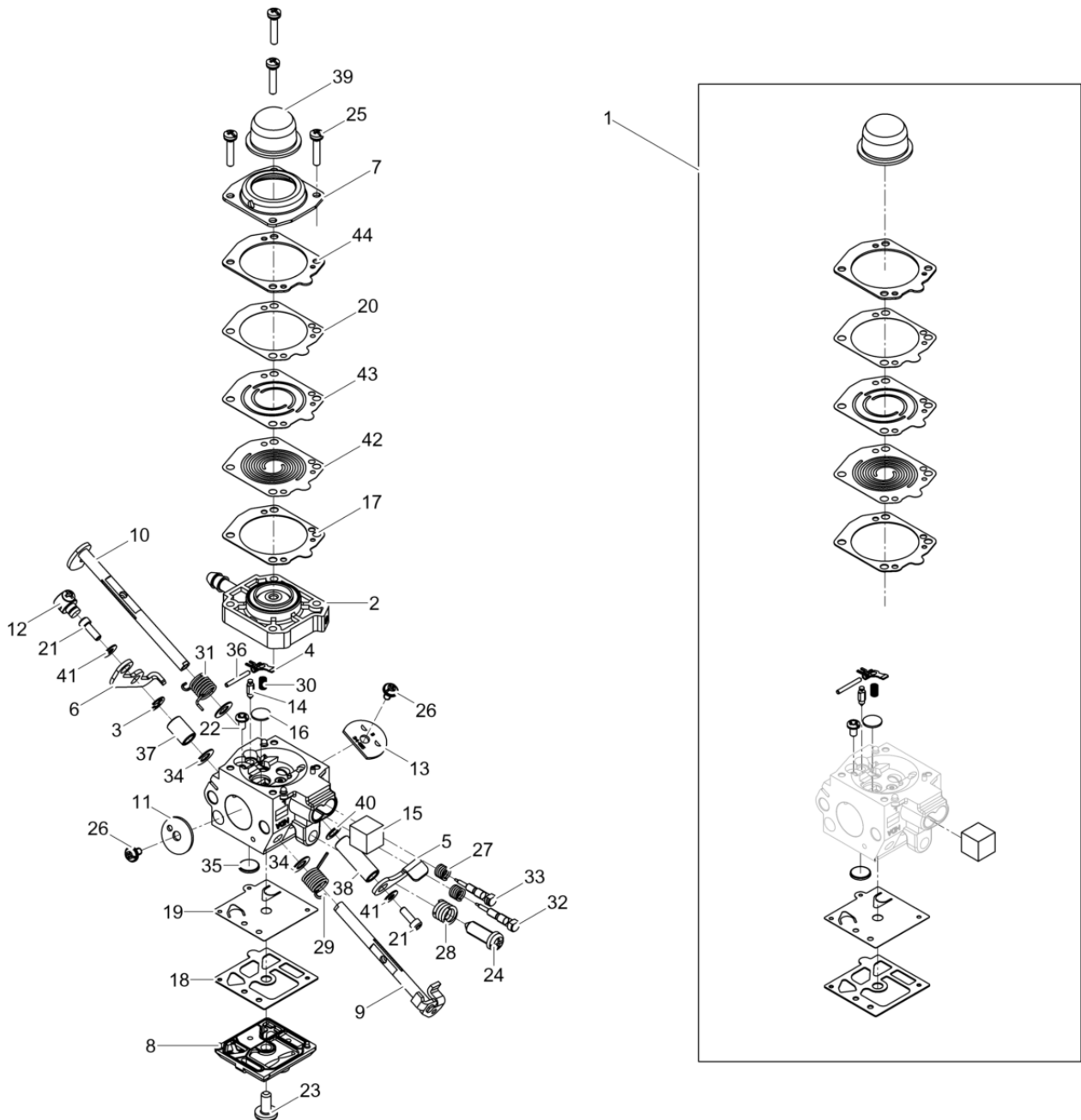



Pos. Item	Artikel Nr. Item no.	Pc.	Unit	Beschreibung Descripción	Description Description	Abm. Dim.	Norm Standard
						Drehmoment Torque	Schmierstoff Lubricant
1	5100068444	1	pc	Reparaturpaket Vergaser HDA355-357 Carburador juego de reparación hda355-357	Carburetor repair kit hda355-357 Carburateur jeu de réparation		
2	5100069840	1	pc	Entlüftungsventil Kpl. Válvula purgadora cpl.	Bleeder valve cpl. Soupape de purge de l'air cpl.		
3	5000182768	1	pc	Sicherungsring Anillo de retención	Retaining ring Bague d'arrêt		
4	5100069843	1	pc	Hebel Palanca	Lever Levier		
5	5000182782	1	pc	Chokehebel Palanca estrangulador	Choke lever Levier - étrangleur		
6	5000182765	1	pc	Gashebel Palanca de regulador	Throttle lever Levier des gaz		
7	5000182773	1	pc	Deckel Tapa	Cover Couvercle		
8	5000222013	1	pc	Deckel Cubierta	Cover Couvercle		
9	5000182781	1	pc	Gasreglerwelle Kpl. Eje de mariposa compl.	Throttle shaft cpl. Arbre des gaz compl.		
10	5100069847	1	pc	Chokewelle Kpl. Eje estrangulador cpl.	Choke shaft cpl. Arbre étrangleur cpl.		
11	5000183357	1	pc	Gasreglerklappe Válvula de estrangulación	Throttle valve Étrangleur		
12	5000183351	1	pc	Drehung Unión giratoria	Swivel Pivot		
13	5100069856	1	pc	Drosselventil Válvula estrangulador	Valve throttle Soupape étranglement		
14	5000182769	1	pc	Einlaßventil Válvula de admisión	Inlet valve Soupape d'admission		
15	5000182784	1	pc	Düse Tobera	Nozzle Ajutage		
16	5000182772	1	pc	Stopfen Tapón	Plug Bouchon		
17	5100069848	1	pc	Dichtung Junta	Seal Joint		
18	5000182759	1	pc	Dichtung Junta	Gasket Joint		
19	5000182760	1	pc	Membran Kpl. Diafragma compl.	Diaphragm cpl. Diaphragme compl.		
20	5100069849	1	pc	Dichtung Junta	Seal Joint		
21	5100028370	2	pc	Zylinderschraube Tornillo hueco	Socket head screw Vis à six-pans creux		
22	5000222015	1	pc	Schraube Tornillo	Screw Vis		
23	5000182757	1	pc	Flachkopfschraube Tornillo de cabeza de cono achatado	Pan head screw Vis ber		
23	5000175299	1	pc	Flachkopfschraube Tornillo de cabeza de cono achatado	Pan head screw Vis ber		
24	5000175310	1	pc	Leerlaufeinstellschraube Tornillo de velocidad de ralenti	Idle speed screw Vis de régime de ralenti		
25	5000175307	4	pc	Schraube Tornillo	Screw Vis		
26	5000175305	2	pc	Schraube Tornillo	Screw Vis		

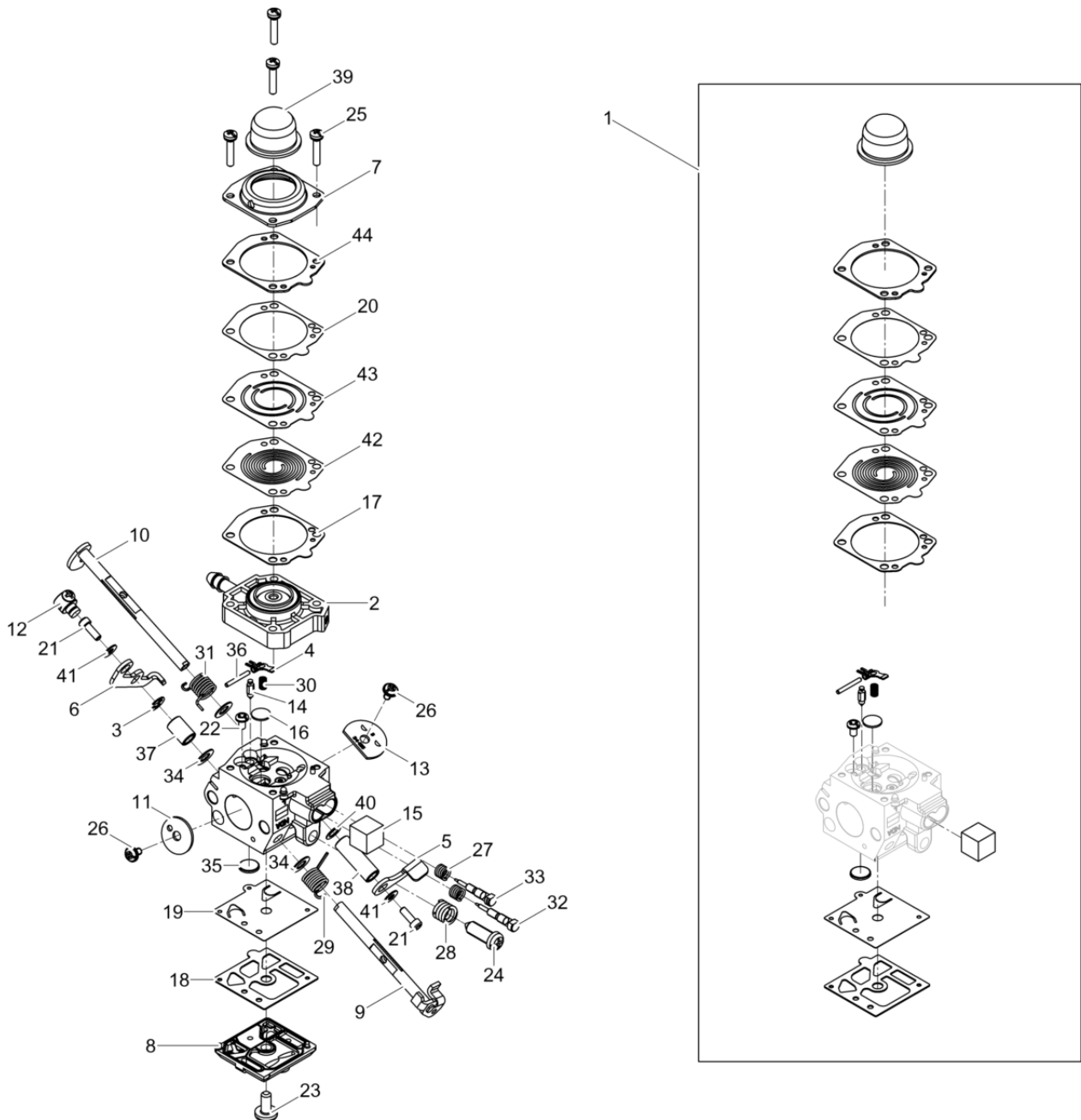

Pos. Item	Artikel Nr. Item no.	Pc.	Unit	Beschreibung Descripción	Description Description	Abm. Dim.	Norm Standard
						Drehmoment Torque	Schmierstoff Lubricant
27	5100069850	2	pc	Feder Resorte	Spring Ressort		
28	5000182778	1	pc	Feder Resorte	Spring Ressort		
29	5100028371	1	pc	Feder Resorte	Spring Ressort		
30	5000175306	1	pc	Feder Resorte	Spring Ressort		
31	5000182762	1	pc	Feder Resorte	Spring Ressort		
32	5100069852	1	pc	Nadelventil Válvula de aguja	Needle valve Soupape à pointeau		
33	5100069853	1	pc	Nadelventil Válvula de aguja	Needle valve Soupape à pointeau		
34	5000175300	3	pc	Scheibe Arandela	Washer Rondelle		
35	5000182761	1	pc	Sieb Tamiz	Screen Tamis		
36	5000182771	1	pc	Stift Pasador	Pin Goupille		
37	5000182764	1	pc	Abstandsstück Espaciador	Spacer Entretoise		
37	5100028372	1	pc	Abstandsstück Espaciador	Spacer Entretoise		
38	5100028373	1	pc	Hülse Manguito	Sleeve Douille		
39	5000182774	1	pc	Birne Bombilla	Bulb Ampoule		
40	5100028374	1	pc	Scheibe Arandela	Washer Rondelle	0,30 ID x 0,19	
41	5100028375	2	pc	Scheibe Arandela	Washer Rondelle		
42	5100069854	1	pc	Membran Membrana	Diaphragm Membrane		
43	5100069851	1	pc	Membran Membrana	Diaphragm Membrane		
44	5100069855	1	pc	Dichtung Junta	Seal Joint		

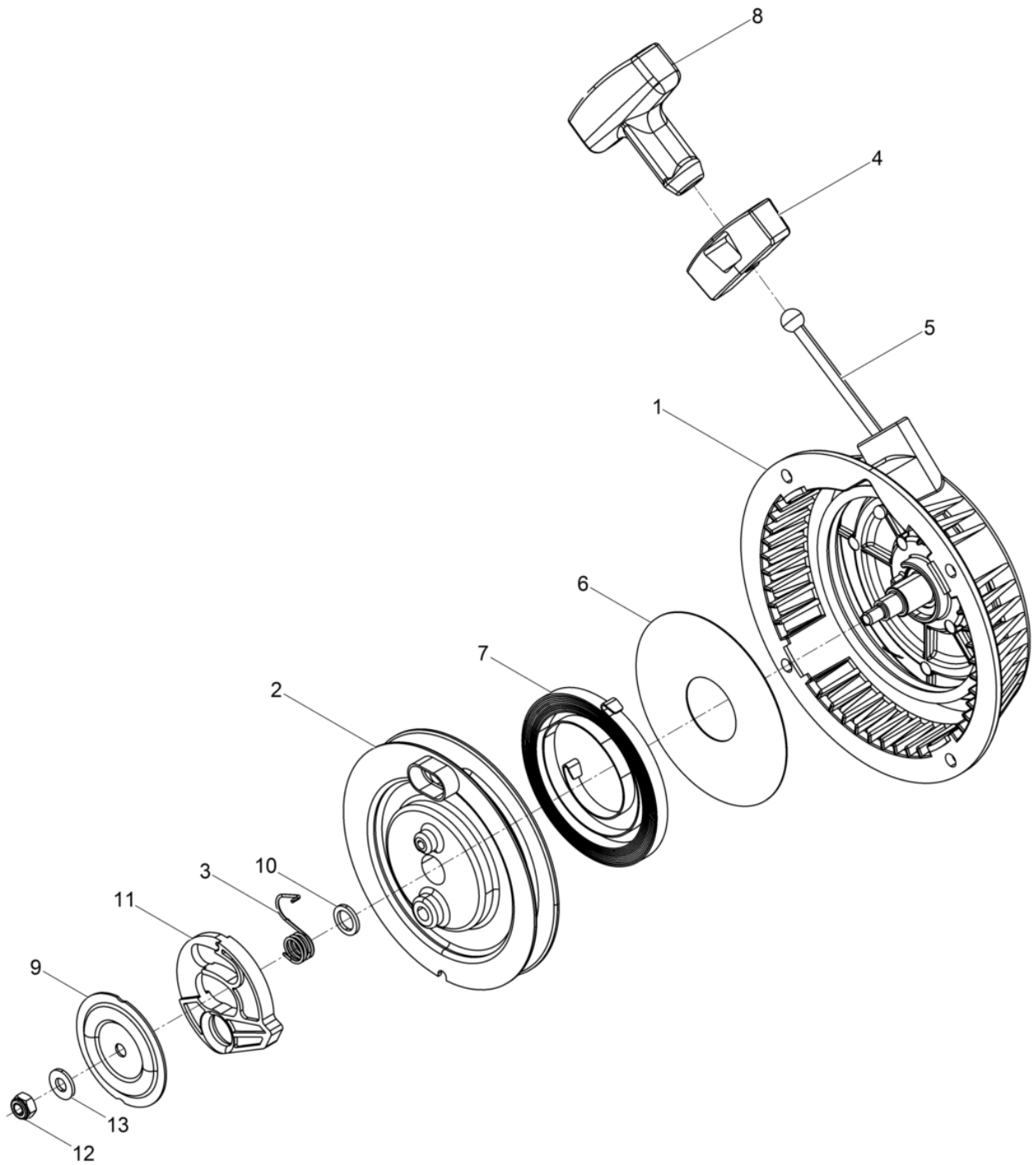

Pos. Item	Artikel Nr. Item no.	Pc.	Unit	Beschreibung Descripción	Description Description	Abm. Dim.	Norm Standard
						Drehmoment Torque	Schmierstoff Lubricant
1	5000048063	1	pc	Startergehäuse Caja del arrancador	Starter housing Carter de démarreur		
2	5000048060	1	pc	Seilscheibe Polea	Starter pulley Poulie de démarrage		
3	5000048059	1	pc	Drehfeder Resorte	Spring Ressort		
4	5000059891	1	pc	Halter Retenedor	Retainer Arrêtoir		
5	5000104548	1	pc	Starterseil Cuerda de arranque	Starter rope Corde de starter		
6	5000065068	1	pc	Anlaufscheibe Arandela tope	Check disc Disque		
7	5000103163	1	pc	Rückholfeder Resorte	Spring Ressort		
8	5000059890	1	pc	Anwerfgriff Empuñadura del arranque	Starter handle Poignée du lanceur		
9	5000047997	1	pc	Führungsscheibe Tapa	Cover Couvercle		
10	5000048062	1	pc	Scheibe Arandela	Washer Rondelle		
11	5000047998	1	pc	Klinke Trinquete	Ratchet (pawl) Cliquet		
12	5000058553	1	pc	Sechskantmutter Tuerca hexagonal	Hexagon nut Écrou hexagonal	M6	DIN980
13	5000058381	1	pc	Spannscheibe Arandela elástica	Lockwasher Rondelle de ressort	6	DIN6796

Auspuff Kpl.  
Muffler cpl.  
Escape cpl.  
Échappement cpl.

BS50-2plus 11in

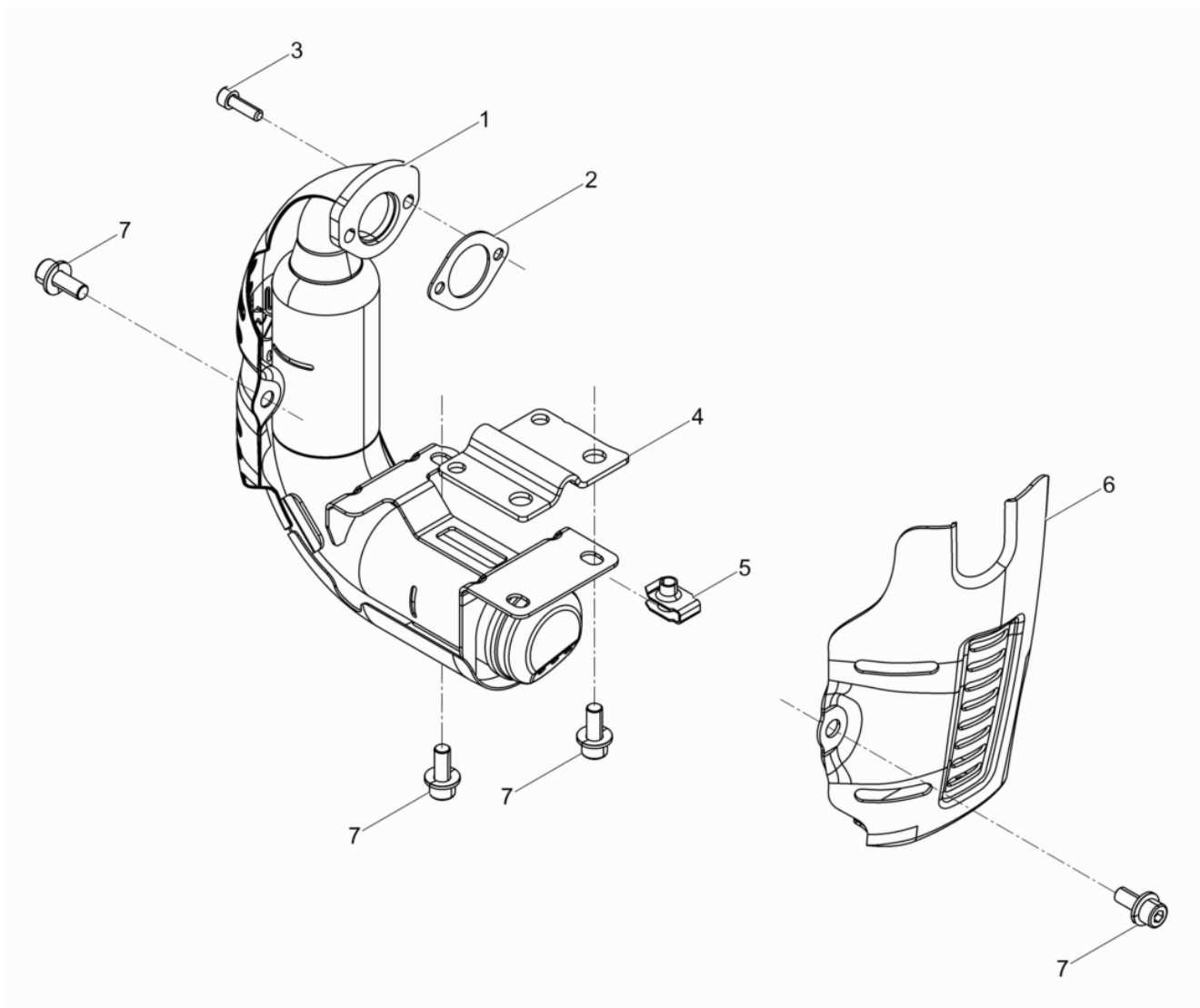

Pos. Item	Artikel Nr. Item no.	Pc.	Unit	Beschreibung Descripción	Description Description	Abm. Dim.	Norm Standard
						Drehmoment Torque	Schmierstoff Lubricant
1	5100032210	1	pc	Auspufftopf Silenciador	Exhaust Pot d'échappement		
2	5100032211	1	pc	Dichtung Junta	Gasket Joint		
3	5000112202	2	pc	Zylinderschraube Tornillo cilíndrico	Cheese head screw Vis à tête cylindrique	M6 x 20	ISO4762
4	5100031731	1	pc	Auspuffkonsole Escape consola	Muffler bracket Échappement console		
5	5100033184	2	pc	Sicherungsmutter Contratuercas	Locknut Contre-écrou		
6	5100032212	1	pc	Schutz Protección	Protection Protection		
7	5000177452	7	pc	Schraube Tornillo	Screw Vis		

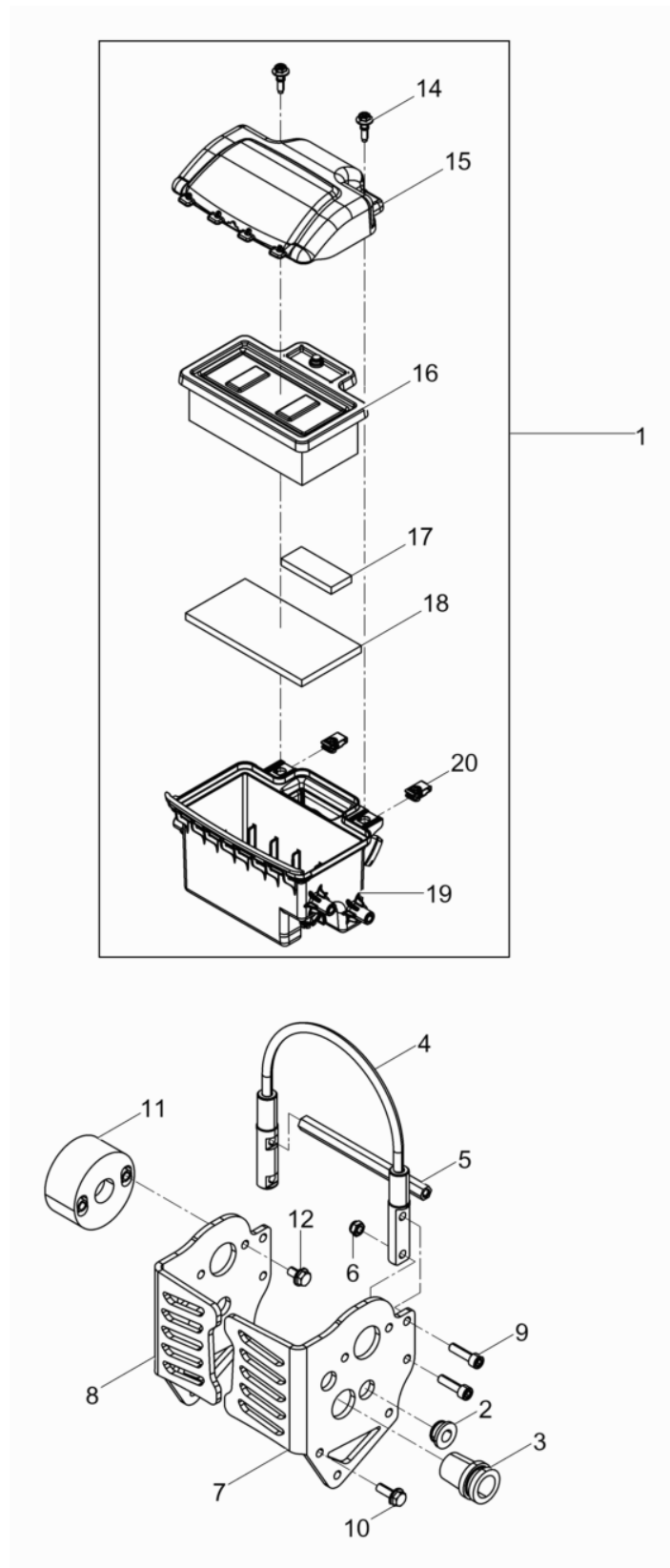



Pos. Item	Artikel Nr. Item no.	Pc.	Unit	Beschreibung Descripción	Description Description	Abm. Dim.	Norm Standard
						Drehmoment Torque	Schmierstoff Lubricant
1	5100032027	1	pc	Luftfilter Filtro del aire	Air cleaner Filtre à air		
2	5100032029	4	pc	Tülle Ojal	Grommet Passe-fil		
3	5100032050	1	pc	Tülle Ojal	Grommet Passe-fil		
4	5100057480	1	pc	Aufhängung Punto para itar	Lifting point Suspension		
5	5100032052	1	pc	Strebe Puntual	Brace Contre-fiche		
6	5000010367	2	pc	Sechskantmutter Tuerca hexagonal	Hexagon nut Écrou hexagonal		DIN985
7	5100028527	1	pc	Seitenblech Links Chapa lateral izquierda	Side plate left Tôle laterale gauche		
8	5100028528	1	pc	Seitenblech Rechts Chapa lateral derecho	Side plate right Tôle laterale droite		
9	5200023260	4	pc	Schraube Tornillo	Screw Vis		
10	5200001667	6	pc	Schraube Tornillo	Screw Vis		
11	5100032053	2	pc	Puffer Amortiguador	Shockmount Silentbloc		
12	5100027072	4	pc	Schraube Tornillo	Screw Vis		
14	5000164398	2	pc	Schraube Des Luftfilterkastens Tornillo de la caja para filtro de aire	Screw-filter, air box Vis de la boîte pour filtre à air		
15	5200007043	1	pc	Deckel Des Luftfilterkastens Tapa de la caja para filtro de aire	Air box filter cover Couvercle de la boîte pour fil		
16	5200003062	1	pc	Filtereinsatz Elemento-filtro	Air filter element Élément filtrant		
17	5200007044	1	pc	Vorfilterelement Elemento del prefiltro	Prefilter element Élément du prénettoyeur		
18	5200007045	1	pc	Filterelement Espume filtro	Foam filter Ecumer le filtre		
19	5200007040	1	pc	Unterteil Des Luftfilterkastens Parte inferior de la caja para filtro de aire	Air box base Partie inférieure de la boîte		
20	5000164397	2	pc	Klemme Des Luftfilterkastens Sujetador de la caja para filtro de aire	Air box filter clip Agrafe de la boîte pour filtre		

Stampfeinsatz Kpl.  
Ramming shoe cpl.  
Pisón cpl.  
Tête de frappe cpl.

BS50-2plus 11in

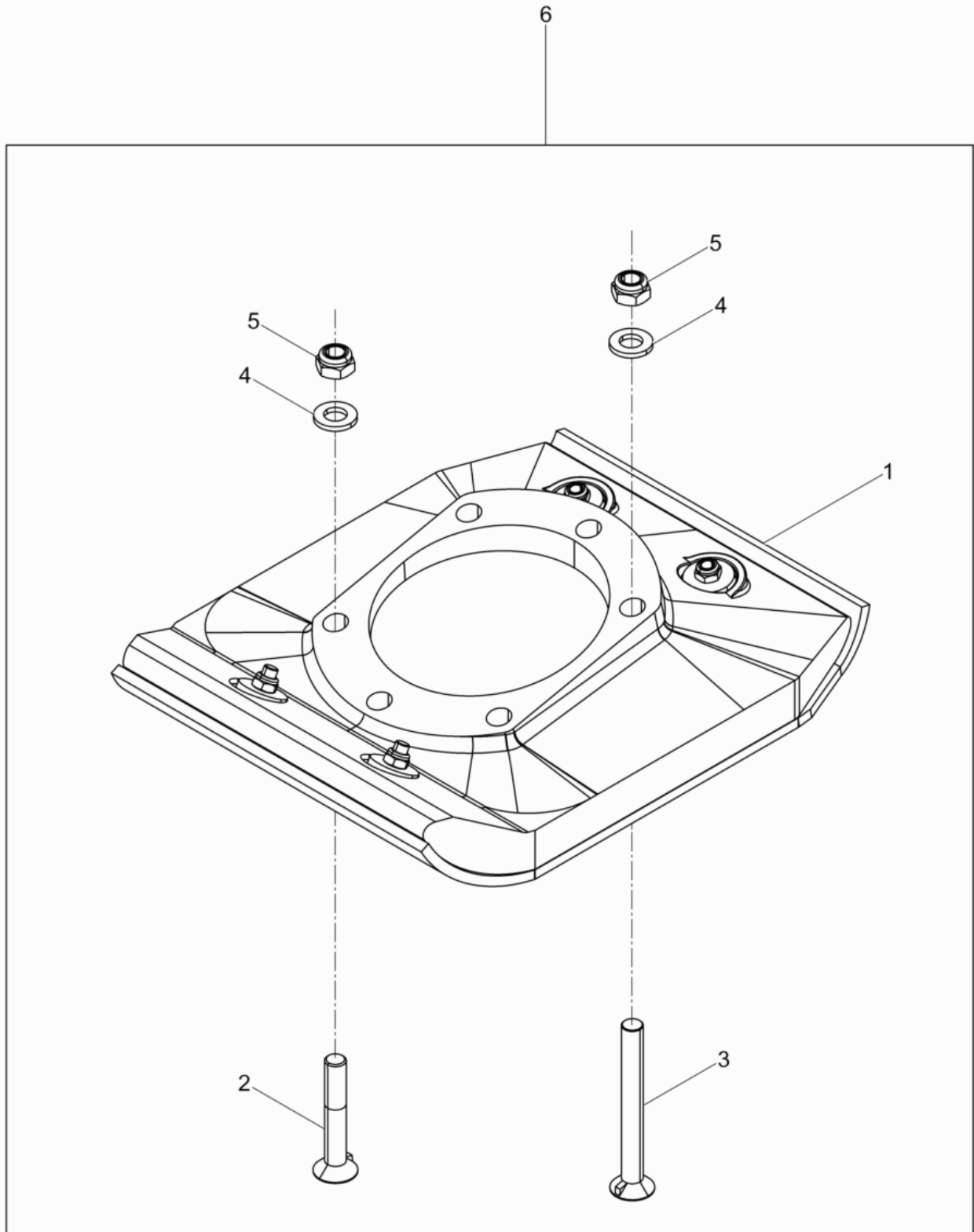

**BS50-2plus 11in****Stampfeinsatz Kpl.  
Ramming shoe cpl.  
Pisón cpl.  
Tête de frappe cpl.**

Pos. Item	Artikel Nr. Item no.	Pc.	Unit	Beschreibung Descripción	Description Description	Abm. Dim.	Norm Standard
						Drehmoment Torque	Schmierstoff Lubricant
1	5100032114	1	pc	Stampfeinsatz 11In Placa de pisón 11in	Ramming shoe 11in Sabot de frappe 11in		
2	5000011158	3	pc	Senkschraube Tornillo avellanado	Countersunk bolt Vis à tête fraisée	M12 x 75 86Nm/63ft.lbs	DIN604
3	5000012983	3	pc	Senkschraube Tornillo avellanado	Countersunk bolt Vis à tête fraisée	M12 x 110 86Nm/63ft.lbs	DIN604
4	5000021465	6	pc	Sicherungsscheibe Arandela de seguridad	Lock washer Rondelle d'arrêt	HS12	
5	5000010366	6	pc	Sechskantmutter Tuerca hexagonal	Hexagon nut Écrou hexagonal	M12X1.75	DIN985
6	5100042452	1	pc	Stampfeinsatz Kpl. 11In Pisón cpl. 11in	Ramming shoe cpl. 11in Tête de frappe cpl. 11in		



Ölpumpe Kpl.  
Oil pump cpl.  
Bomba de aceite cpl.  
Pompe à huile cpl.

BS50-2plus 11in

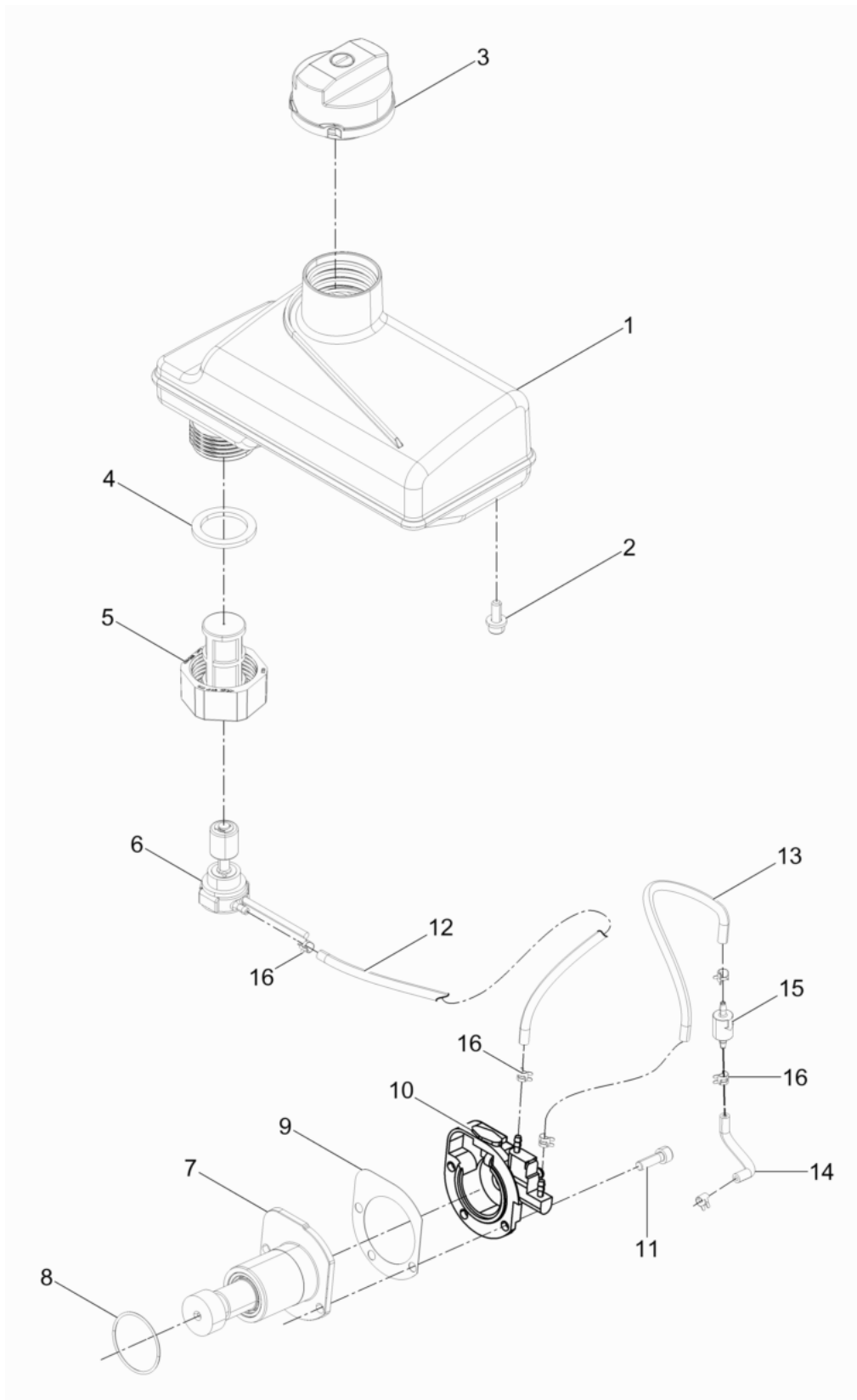

Pos. Item	Artikel Nr. Item no.	Pc.	Unit	Beschreibung Descripción	Description Description	Abm. Dim.	Norm Standard
						Drehmoment Torque	Schmierstoff Lubricant
1	5100030301	1	pc	Öltank Tanque de aceite	Oil tank Réservoir d'huile		
2	5000160861	4	pc	Schraube Tornillo	Screw Vis	M6 x 16	
3	5100030408	1	pc	Öltankdeckel Tapa de tanque	Oil tank cap Couvercle du réservoir		
4	5000086312	1	pc	Dichtungsring Anillo sellador	Ring seal Rondelle à étancher		
5	5100038375	1	pc	Ölfilter Filtro de aceite	Oil filter Filtre d'huile		
6	5100034608	1	pc	Schwimmschalter Interruptor del flotador	Float switch Interrupteur à flotteur		
7	5100031988	1	pc	Antriebswelle Albero comando	Driving shaft Arbre d'entraînement		
8	5000150278	1	pc	O-Ring Anillo-o	O-ring Joint torique	1,50 x 0,07in	
9	5100031989	1	pc	Dichtung Junta	Gasket Joint		
10	5100032060	1	pc	Ölpumpe Bomba de aceite	Oil pump Pompe à huile		
11	5000011551	3	pc	Zylinderschraube Tornillo cilíndrico	Cheese head screw Vis à tête cylindrique	95Nm/70ft.lbs	
12	5100035892	1	pc	Ölschlauch Manguera de aceite	Oil hose Tuyau d'huile		
13	5100049757	1	pc	Ölschlauch Manguera de aceite	Oil hose Tuyau d'huile		
14	5100049758	1	pc	Ölschlauch Manguera de aceite	Oil hose Tuyau d'huile		
15	5100035981	1	pc	Rückschlagventil Válvula de retención	Back pressure valve Soupape de retenue		
16	5100035982	6	pc	Schlauchklemme Abrazadera	Clamp Collier de serrage		

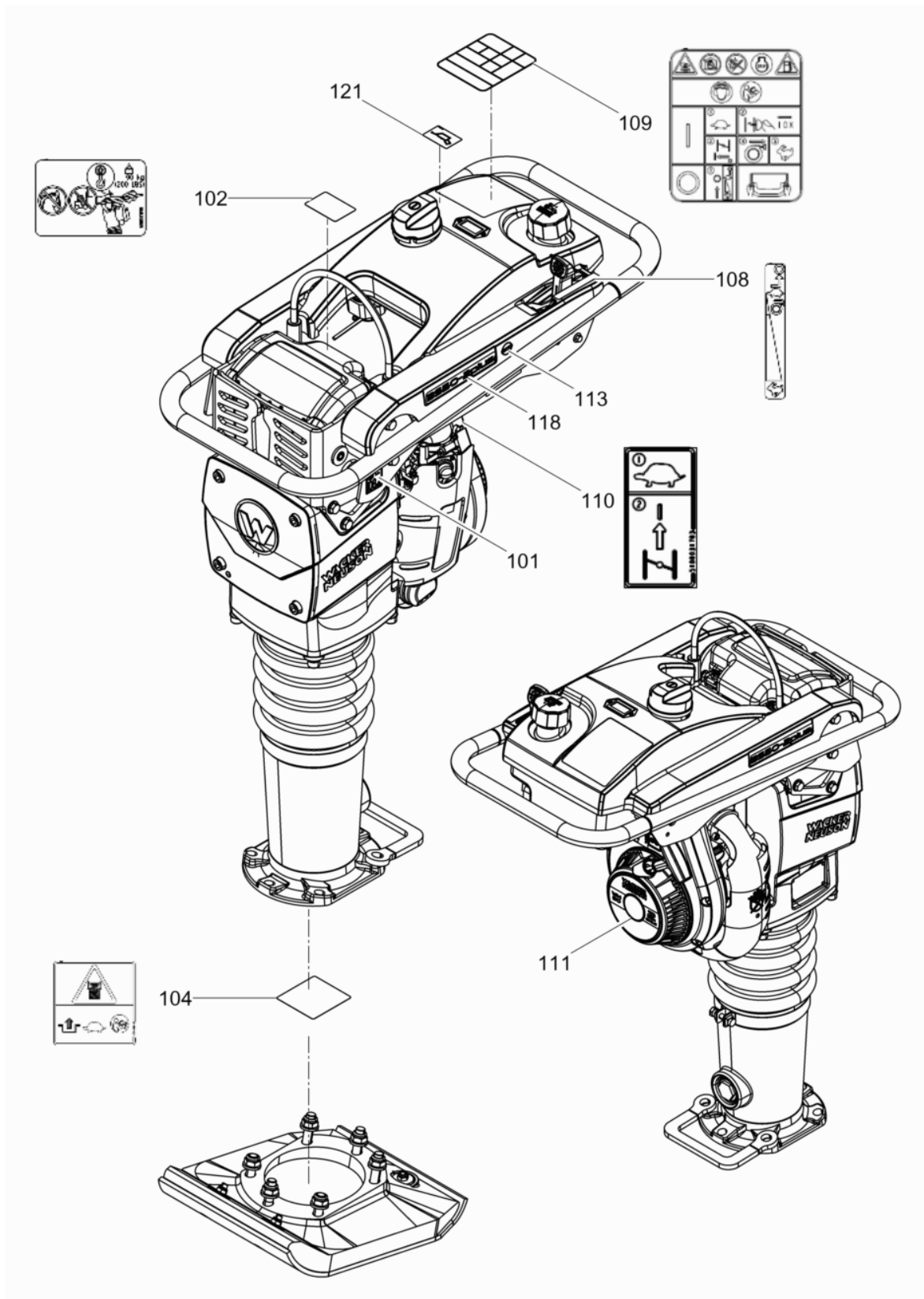

Pos. Item	Artikel Nr. Item no.	Pc.	Unit	Beschreibung Descripción	Description Description	Abm. Dim.	Norm Standard
						Drehmoment Torque	Schmierstoff Lubricant
101	5000129784	1	pc	Aufkleber-Schalleistungspegel Etiqueta autoadhesiva-nivel de potencia acúëstica	Decal-sound power level Autocollante-niveau sonore		
102	5100031690	1	pc	Aufkleber Hebepunkt Calcomania punto de elevación	Label lifting point Autocollant point de levage		
104	5100031693	1	pc	Aufkleber Druckfeder Calcomania resorte de compresión	Label compression spring Autocollant ressort de		
108	5100031697	1	pc	Aufkleber Starter Calcomania arrancador	Label starter Autocollant démarreur		
109	5100031699	1	pc	Aufkleber Start / Stop Auto Calcomania start / stop auto	Label start / stop auto Autocollant start / stop auto		
110	5100031703	1	pc	Aufkleber Starter AN - AUS Calcomania arrancador	Label starter Autocollant démarreur		
111	5100031704	1	pc	Aufkleber WM80 Calcomania wm80	Label wm80 Autocollant wm80		
113	5100009603	1	pc	Aufkleber ECO Calcomania eco	Label eco Autocollant eco		
118	5100031720	2	pc	Aufkleber Typ Tipo etiqueta autoadhesiva	Type label Autocollant de type		
121	5100036130	1	pc	Aufkleber Ölkanne Calcomania aceitera	Label oil can Autocollant burette		

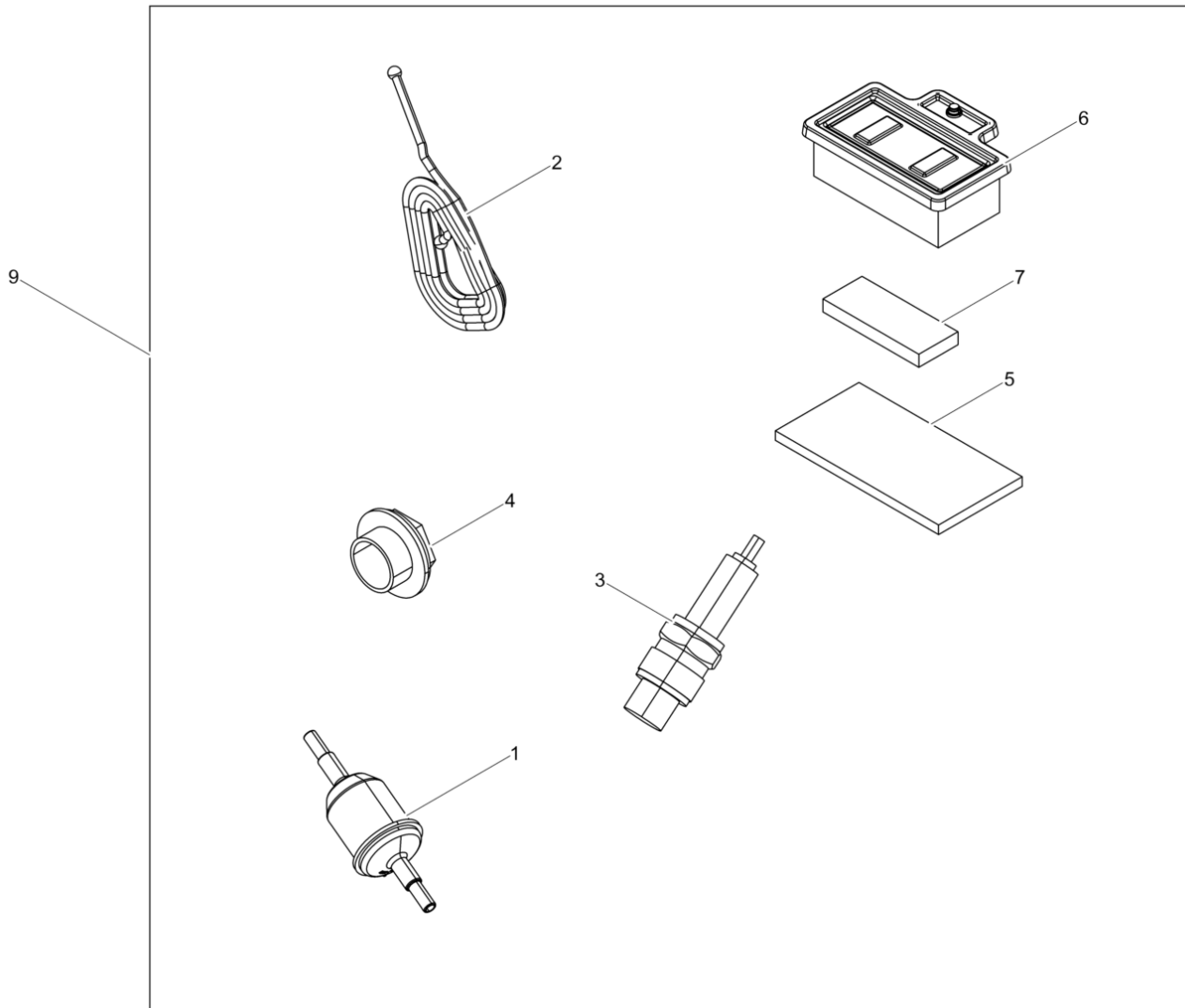



Pos. Item	Artikel Nr. Item no.	Pc.	Unit	Beschreibung Descripción	Description Description	Abm. Dim.	Norm Standard
						Drehmoment Torque	Schmierstoff Lubricant
1	5100068032	1	pc	Kraftstofffilter Filtro de combustible	Fuel filter Filtre à carburant		
2	5000104548	1	pc	Starterseil Cuerda de arranque	Starter rope Corde de starter		
3	5000172332	1	pc	Zündkerze Bujía	Spark plug Bougie		
4	5100033182	1	pc	Ölstandsauge Indicador de aceite	Sight glass Indicateur		
5	5200007044	1	pc	Vorfilterelement Elemento del prefiltro	Prefilter element Élément du prénettoyeur		
6	5200003062	1	pc	Filtereinsatz Elemento-filtro	Air filter element Élément filtrant		
7	5200007045	1	pc	Filterelement Espume filtro	Foam filter Ecumer le filtre		
9	5100009863	1	pc	Wartungspaket Juego para mantenimiento	Maintenance kit Jeu d'entretien		

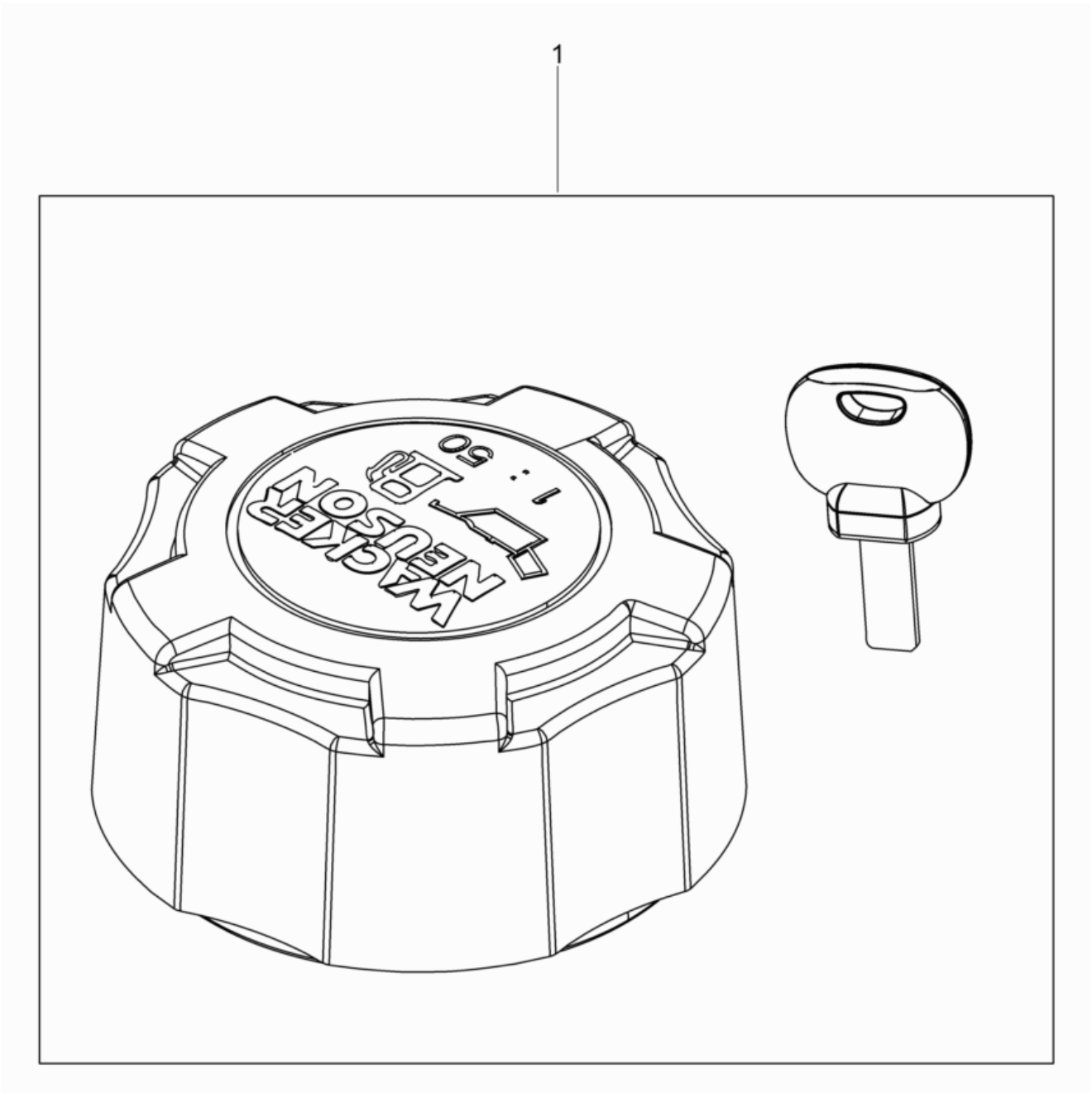

**BS50-2plus 11in****Öltankdeckel Abschliessbar  
Oil tank cap lockable  
Tapa de tanque cerrable  
Couvercle du réservoir fermant**

Pos. Item	Artikel Nr. Item no.	Pc.	Unit	Beschreibung Descripción	Description Description	Abm. Dim.	Norm Standard
						Drehmoment Torque	Schmierstoff Lubricant
1	5100035985	1	pc	Öltankdeckel Abschliessbar Tapa de tanque cerrable	Oil tank cap lockable Couvercle du réservoir fermant		



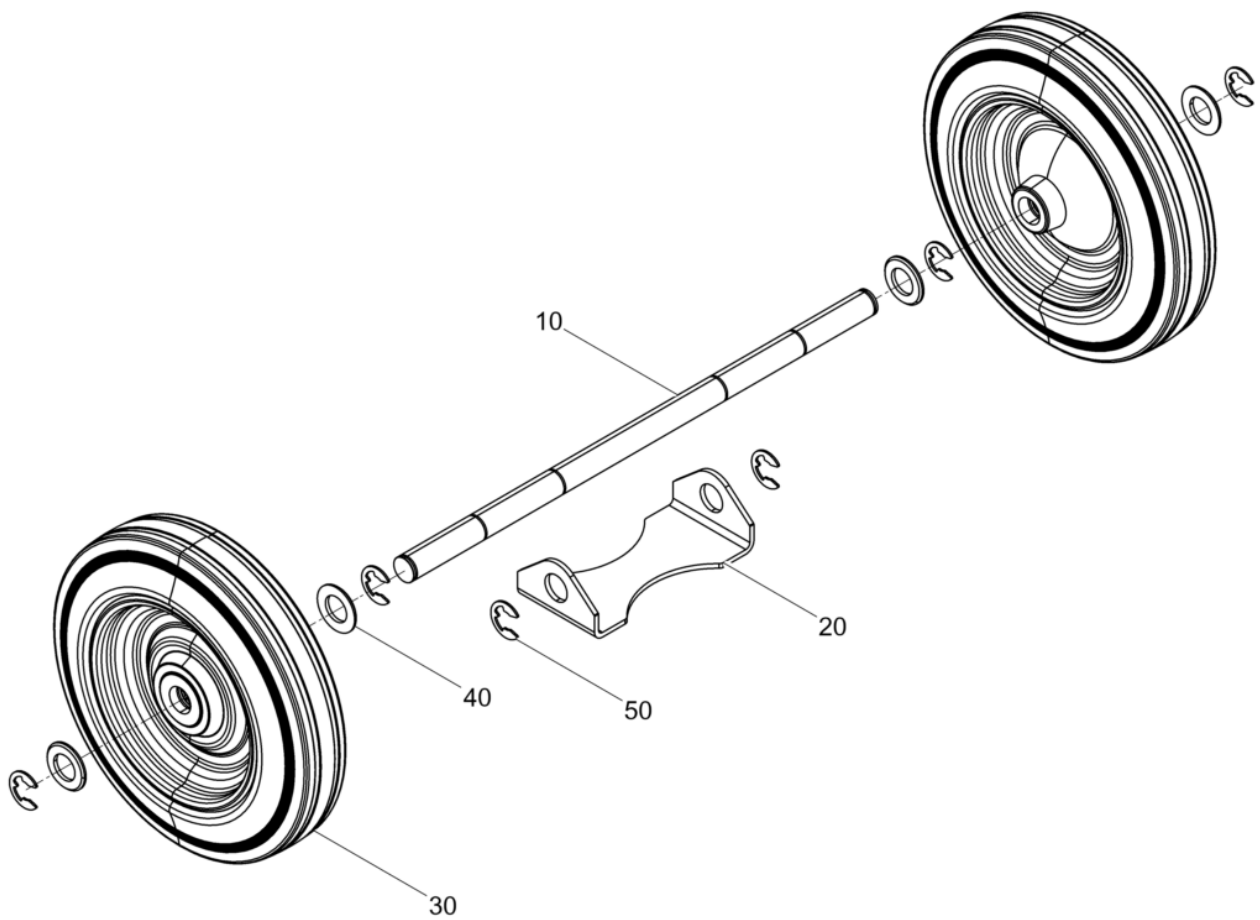

Pos. Item	Artikel Nr. Item no.	Pc.	Unit	Beschreibung Descripción	Description Description	Abm. Dim.	Norm Standard
						Drehmoment Torque	Schmierstoff Lubricant
10	5100064461	1	pc	Achse Eje	Axle Axe		
20	5100064462	1	pc	Platte Placa	Plate Plaque		
30	5100064463	2	pc	Rad Rueda	Tire Rueda		
40	5000010616	4	pc	Scheibe Arandela	Flat washer Rondelle		
50	5000103834	6	pc	Sicherungsscheibe Arandela de seguridad	Lock washer Rondelle d'arrêt	15	DIN6799







**WACKER  
NEUSON**

