



**WACKER
NEUSON**

Ersatzteilkatalog
Spare parts catalog
Catálogo de piezas de repuesto
Catalogue de pièces de rechange

**Aufbruchhammer
Demolition breaker
Martillo rompedor
Marteau piqueur**

**BH55RW RS
27X80**



Type	BH55RW RS 27X80
Material Number	5100047103
Version	101
Language	de en es fr



www.wackerneuson.com

Copyright © 08.2023
Wacker Neuson Produktion GmbH & Co. KG
Printed in Germany.
All rights reserved.

Ein Typenschild mit Typ, Artikelnummer, Version und Maschinen-Nummer ist an jedem Gerät angebracht. Die Daten von diesem Schild bitte notieren, damit sie auch bei Verlust oder Beschädigung des Schildes noch vorhanden sind. Der Typ, die Artikelnummer, die Versions-Nummer und die Maschinen-Nummer sind bei der Ersatzteilbestellung oder Nachfragen bezüglich Service-Informationen stets erforderlich.

Bei den in den Ersatzteillisten fettgedruckten Nummern handelt es sich um empfohlene Ersatzteile. Dies bedeutet, daß diese Teile bei normalen Anwendungsbedingungen natürlicher Abnutzung ausgesetzt sind und gelegentlich ersetzt oder überarbeitet werden müssen. Es wird geraten, diese Teile auf Lager bereit zu haben, um für Service-Arbeiten an diesem Gerät vorbereitet zu sein. Lagerbestände für diese und andere Teile, welche für ausgiebigere Reparaturarbeiten benötigt werden, können je nach Service-Gewohnheiten der einzelnen Kunden variieren.

Die Nummern meines Gerätes sind:

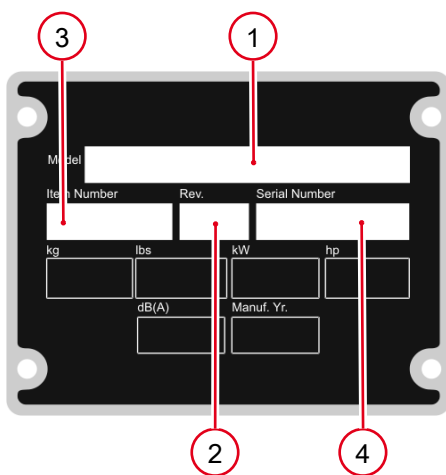

1. Typ
2. Version
3. Artikel-Nr.
4. Maschinen-Nr.

Umrechnungstabelle

Volumeneinheit	
1 ml	0.034 US fl.oz.
1 l	0.260 gal
Längeneinheit	
1 mm	0.039 in
1 m	3.280 ft
Gewicht	
1 kg	2.200 lbs
1 g	0.035 oz
Geschwindigkeit	
1 km/h	0.620 mph
Drehmoment	
1 Nm	0.740 ft.lbs

A nameplate listing the Model Number, Item Number, Revision, and Serial Number is attached to each unit. Please record the information found on this plate so it will be available should the nameplate become lost or damaged. When ordering parts or requesting service information, you will always be asked to specify the model, item number, revision number, and serial number of the unit.

Part Numbers appearing in boldface type are recommended spare parts. This means that these parts are subject to wear under normal operating conditions and may require periodic service or replacement. It is recommended that these items be stocked to meet the expected service requirements of this model. Actual stocking quantities of these and other parts used in more extensive repairs will depend on the service practices of each customer.

My machine's numbers are:



1. Model
2. Revision
3. Item No.
4. Serial No.

Conversion table

Volume unit	
1 ml	0.034 US fl.oz.
1 l	0.260 gal
Unit of length	
1 mm	0.039 in
1 m	3.280 ft
Weight	
1 kg	2.200 lbs
1 g	0.035 oz
Speed	
1 km/h	0.620 mph
Torque	
1 Nm	0.740 ft.lbs

Una placa de identificación con el modelo, número de referencia, nivel de revisión y número de serie ha sido añadida en cada máquina. Favor de anotar los datos en la placa en caso de que la placa de identificación sea destruida o perdida. En todos los pedidos para repuestos necesita siempre el modelo, el número de referencia, el nivel de revisión y el número de serie de la máquina en cuestión.

Los números de partes en negritas en las Listas Ilustradas de Partes son los repuestos recomendados, esto quiere decir que estas partes se desgastarán bajo circunstancias de funcionamiento normales y pueden requerir servicio periódico o su reemplazo. Se recomienda que el cliente mantenga un abastecimiento adecuado de estas partes para poder satisfacer la demanda requerida por el servicio a la máquina. La cantidad de repuestos que el cliente necesitará para reparaciones dependerá de la póliza de servicio de cada cliente.

Los números de mi máquina son:

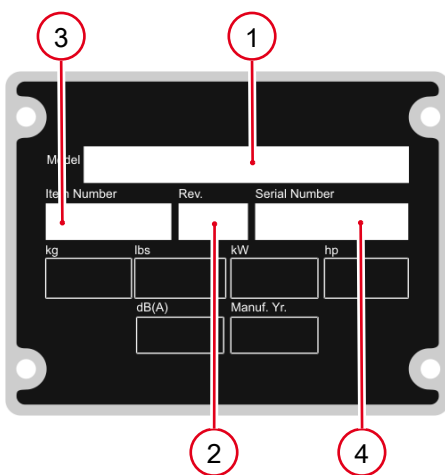

1. Modelo
2. Nivel de revisión
3. Número de referencia
4. Número de Serie

Tabla de conversión

Unidad de volumen	
1 ml	0.034 US fl.oz.
1 l	0.260 gal
Unidad de longitud	
1 mm	0.039 in
1 m	3.280 ft
Peso	
1 kg	2.200 lbs
1 g	0.035 oz
Velocidad	
1 km/h	0.620 mph
Par de apriete	
1 Nm	0.740 ft.lbs

Une plaque signalétique mentionnant le modèle, le numéro de référence, le niveau de revision et le numéro de série est fixée sur chaque machine. Veuillez noter les informations relevées sur cette plaque de façon à ce qu'elles soient toujours disponibles si la plaque signalétique venait à être perdue ou endommagée. Lorsque vous commandez des pièces détachées ou vous sollicitez des informations après-vente, on vous demandera toujours de préciser le modèle, le numéro de référence, le niveau de revision et le numéro de série de la machine.

Les numéros de pièces imprimés en caractères gras dans les Listes des Pièces Détachées de ce manuel sont les pièces détachées recommandées par la Wacker. Cela veut dire que ces pièces sont sujettes à usure dans des conditions de travail normales et peuvent nécessiter de l'entretien ou leur remplacement. Nous recommandons que vous disposez d'un stock de ces pièces pour pouvoir satisfaire la demande d'entretien de cette machine. Le client doit décider lui-même de la quantité exacte de pièces de rechange qu'il disposera dans ses stocks.

Les numéros de ma machine sont :

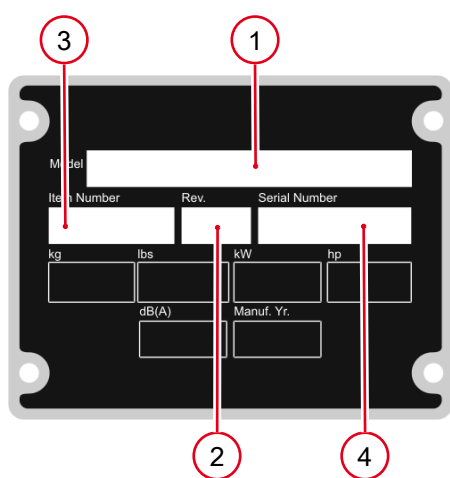

1. Typ
2. Version
3. Artikel-Nr.
4. Maschinen-Nr.

Table de conversion

Unité de volume	
1 ml	0.034 US fl.oz.
1 l	0.260 gal
Unité de longueur	
1 mm	0.039 in
1 m	3.280 ft
Poids	
1 kg	2.200 lbs
1 g	0.035 oz
Vitesse	
1 km/h	0.620 mph
Couple de serrage	
1 Nm	0.740 ft.lbs

Verkleidung Kpl. Hood cpl. Revestimiento cpl. Revetement cpl.	10
---	----

Tank Kpl. Tank cpl. Tanque cpl. Réservoir cpl.	12
--	----

Kurbelgehäuse Kpl. Crankcase cpl. Cárter cpl. Carter cpl.	14
---	----

Schlagwerk-Führungszylinder Striking mechanism-cylinder guide Mecanismo llamativo-cilindro de guía Mécanisme saisissant-cylindre	16
---	----

Werkzeughalter Tool holder Porta-herramientas Porte-outils	18
---	----

Motor Kpl. Rs Engine cpl. rs Motor cpl. rs Moteur cpl. rs	20
--	----

Standardmotor Rs Standard engine rs Motor standard rs Moteur standard rs	22
---	----

Reparatursatz Vergaser HDA-290 Repair kit carburetor hda-290 Juego de reparación carburadorhda-290 Jeu de réparation carburateur	26
---	----

Vergaser HDA-354 Carburetor hda-354 Carburador hda-354 Carburateur hda-354	28
---	----

Reversierstarter Kpl. WM80c Recoil starter cpl. wm80c Starter reversible cpl. wm80c Démarreur réversible cpl.	32
---	----

Aufkleber Labels Calcomanías Autocollants	34
--	----

Zubehör Accessories Accesorios Accessoires	
---	--

Transportwagen Kpl.	
Cart transportation cpl.	
Carro transportación cpl.	
Voiturette transport cpl.	36

Transportwagen Kpl.	
Cart transportation cpl.	
Carro transportación cpl.	
Voiturette transport cpl.	38



Verkleidung Kpl.
Hood cpl.
Revestimiento cpl.
Revetement cpl.

BH55RW RS 27X80

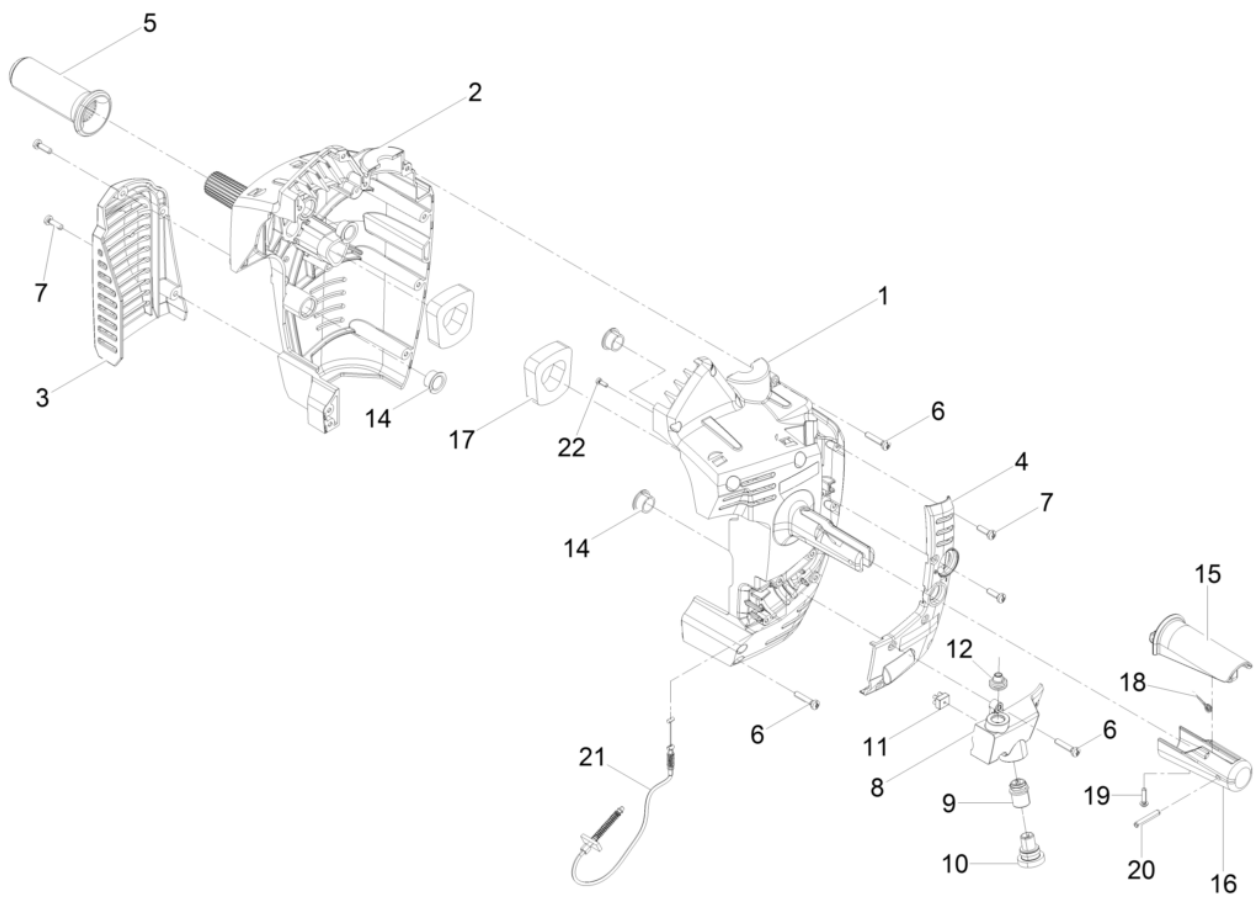

Pos. Item	Artikel Nr. Item no.	Pc.	Unit	Beschreibung Descripción	Description Description	Abm. Dim.	Norm Standard
						Drehmoment Torque	Schmierstoff Lubricant
1	5100025242	1	pc	Verkleidung Vergaserseitig Revestimiento lado carburador	Hood carburetor side Revetement part carburateur		
2	5100036372	1	pc	Verkleidung Auspuffseitig Hood exhaust side	Hood exhaust side Revetement part échappement		
3	5000213533	1	pc	Abdeckung Cobertura	Covering Couvercle		
4	5100025241	1	pc	Deckel Tapa	Cover Couvercle		
5	5000105006	1	pc	Handgriff Empuñadura	Handle Poignée		
6	5000108370	12	pc	Linsenkopfschraube Tornillo gota de sebo	Oval head screw Vis noyée lentiforme		
7	5000222605	7	pc	Linsenkopfschraube Tornillo gota de seboatado	Oval head screw Vis noyée lentiforme	M 6 x 20	
8	5100031561	1	pc	Gehäuse Carcasa	Housing Carter		
9	5000105010	1	pc	Dose Kpl. Caja	Box cpl. Douille cpl.		
10	5000105016	1	pc	Blindstecker Enchufe	Blind plug Fiche borgne		
11	5000020064	1	pc	Klemmleiste Regleta de sujeción	Terminal strip Triangle de serrage		
12	5100060760	1	pc	Kabeldurchführung Conducto de cable	Cable passage Passage de câble		
13	5000206683	1	pc	Kabelbinder T30L Fijación de cables t30l	Cable yarn t30l Attache de câble t30l		
14	5100032401	4	pc	Gleitlager Cojinete deslizante	Slide bearing Roulement de glissement		
15	5000222523	1	pc	Schalthebel Palanca de cambios	Shift lever Lever de change		
16	5000209490	1	pc	Hülse Collar	Collar Douille		
17	5000203763	2	pc	Anschlagpuffer Amortiguador	Shockmount Silentbloc		
18	5000212561	1	pc	Schenkelfeder Resorte	Spring Ressort		
19	5000212562	1	pc	Linsenschraube Tornillo gota de sebo	Countersunk screw Vis à tête bombée	5 x 20	
20	5000015994	1	pc	Spiralspannstift Perno de sujeción	Spring dowel sleeve Goupille élastique	6 x 36	DIN7343
21	5000222383	1	pc	Bowdenzug Cable bowden	Bowden cable Câble de bowden		
22	5000213543	1	pc	Linsenkopfschraube Tornillo gota de seboatado	Oval head screw Vis noyée lentiforme	4x12	

Tank Kpl.
Tank cpl.
Tanque cpl.
Réservoir cpl.

BH55RW RS 27X80

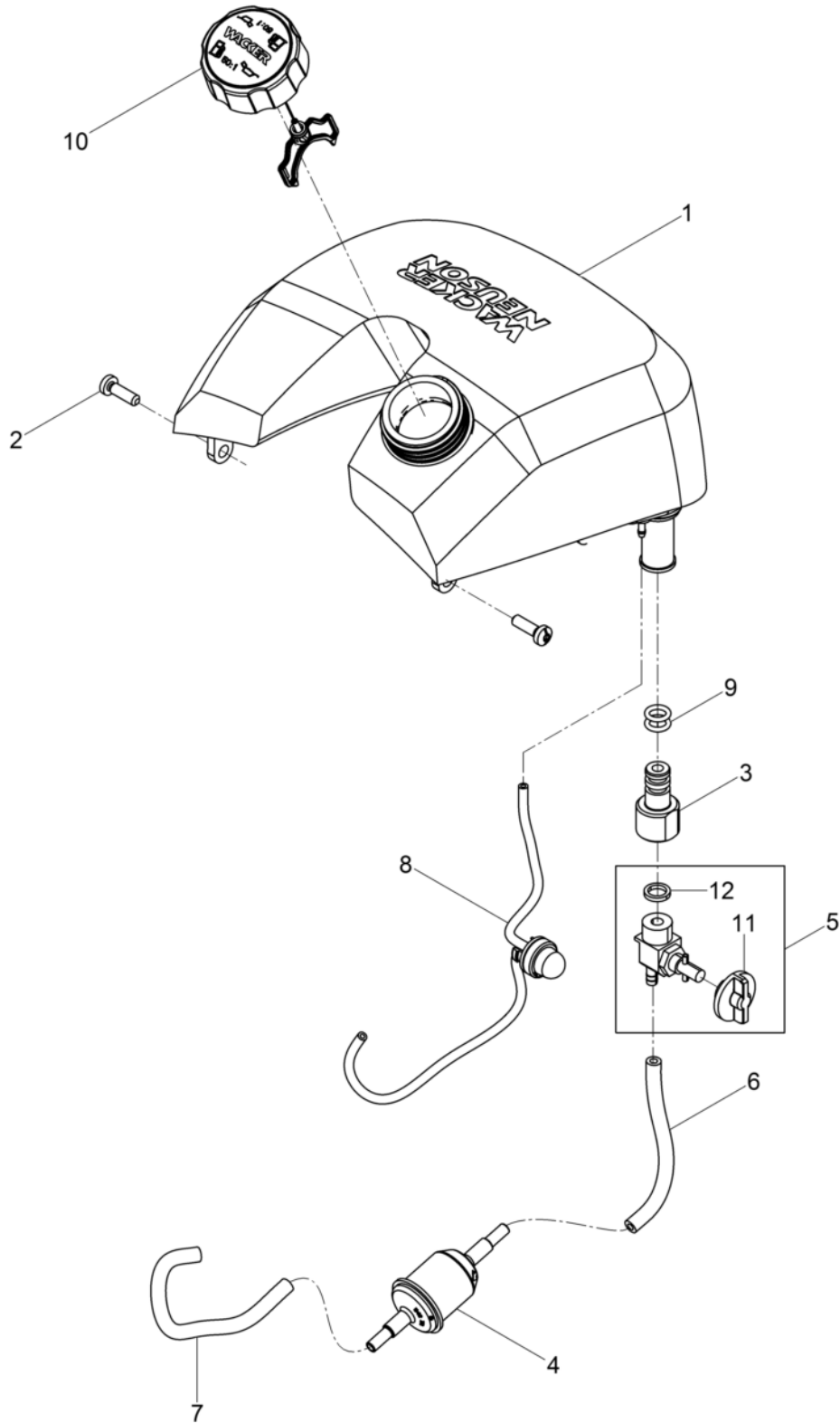

Pos. Item	Artikel Nr. Item no.	Pc.	Unit	Beschreibung Descripción	Description Description	Abm. Dim.	Norm Standard
						Drehmoment Torque	Schmierstoff Lubricant
1	5000213520	1	pc	Kraftstofftank Depósito de combustible	Fuel tank Réservoir à essence		
2	5000222605	5	pc	Linsenkopfschraube Tornillo gota de seboatado	Oval head screw Vis noyée lentiforme	M 6 x 20	
3	5000222378	1	pc	Anschlusstutzen Manguito	Muff Manchon		
4	5100022620	1	pc	Kraftstofffilter Filtro de combustible	Fuel filter Filtre à carburant		
5	5000222410	1	pc	Kraftstoffhahn Llave de combustible	Fuel cock Robinet d'essence		
6	5100014349	1	pc	Kraftstoffschlauch Manguera de combustible	Fuel hose Tuyau à essence		
7	5100014347	1	pc	Kraftstoffschlauch Manguera de combustible	Fuel hose Tuyau à essence		
8	5100036725	1	pc	Purger Mit Schlauch Bomba de combustible con manguera	Purger with hose Pompe à essence avec tuyau		
9	5000222610	2	pc	O-Ring Anillo-o	O-ring Joint torique	9x2,5	EN549
10	5000163681	1	pc	Tankdeckel Kpl. Tapa de tanque cpl.	Tank cover cpl. Couvercle du reservoir cpl.		
11	5000222421	1	pc	Betätigungsknopf Botón de accionamiento	Operating knop Bouton de manoeuvre		
12	5000222379	1	pc	Flachdichtung Junta	Gasket Joint	8x14x5	

Kurbelgehäuse Kpl.
Crankcase cpl.
Cárter cpl.
Carter cpl.

BH55RW RS 27X80

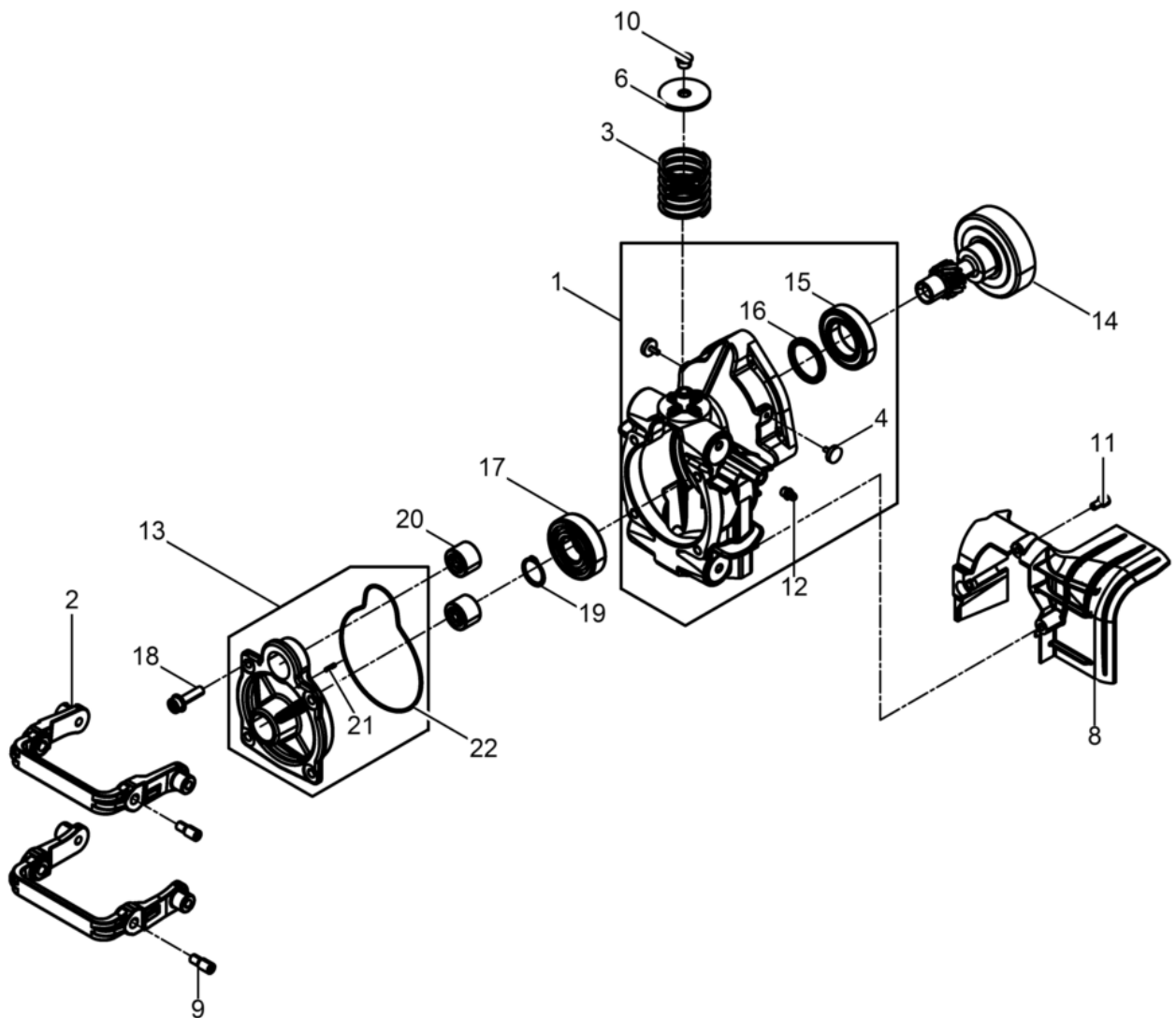

Pos. Item	Artikel Nr. Item no.	Pc.	Unit	Beschreibung Descripción	Description Description	Abm. Dim.	Norm Standard
						Drehmoment Torque	Schmierstoff Lubricant
1	5100001472	1	pc	Kurbelgehäuse Cárter	Crankcase Carter		
2	5000222472	2	pc	Schwinge Brazo de elevación	Lifting arm Bras de levage		
3	5000203765	1	pc	Druckfeder Resorte de compresión	Compression spring Ressort de pression		
4	5000207279	2	pc	Puffer Amortiguador	Shockmount Silentbloc	60x4	
6	5100002282	1	pc	Scheibe Arandela	Washer Rondelle	Ø11	
8	5000213526	1	pc	Luftführung Conducción de aire	Air ducting Carter ventilation		
9	5000211346	4	pc	Schraubenbolzen Tornillo	Screw Vis	M8	
10	5000222425	1	pc	Stopfen Enchufe	Plug Prise		
11	5100055395	3	pc	Zylinderschraube Tornillo cilíndrico	Cheese head screw Vis à tête cylindrique	10Nm/7ft.lbs	
12	5000222551	1	pc	Kegelschmiernippel Engrasador cónico	Tapered nipple Graisseur		DIN71412
13	5100001469	1	pc	Lagerflansch Kpl. Brida-rodamiento	Bearing flange Collerette-roulement		
14	5000202570	1	pc	Fliehkraftglocke Campana centrífuga	Clutch drum Carter embrayage		
15	5100000102	1	pc	Rillenkugellager Rodamiento a bolas	Grooved ball bearing Roulement rainuré à billes	6007	
16	5100001451	1	pc	Radial-Wellendichtring Anillo de sellado	Sealing ring Anneau d'étanchéité	35x45x4	
17	5000104712	1	pc	Rillenkugellager Rodamiento a bolas	Grooved ball bearing Roulement rainuré à billes		
18	5000222467	4	pc	Rippschraube Tornillo	Screw Vis	M 8x 30	
19	5002001041	1	pc	Sicherungsring Anillo de retención	Retaining ring Bague d'arrêt	25 x 1,2	DIN471
20	5100046173	2	pc	Nadelbüchse Cojinete de agujas	Needle bushing Douille d'aiguilles		
21	5000209452	2	pc	Spannstift Pasador	Roll pin Goupille de tension	3,0x 12	
22	5100001449	1	pc	O-Ring Anillo-o	O-ring Bague-o	115x2	

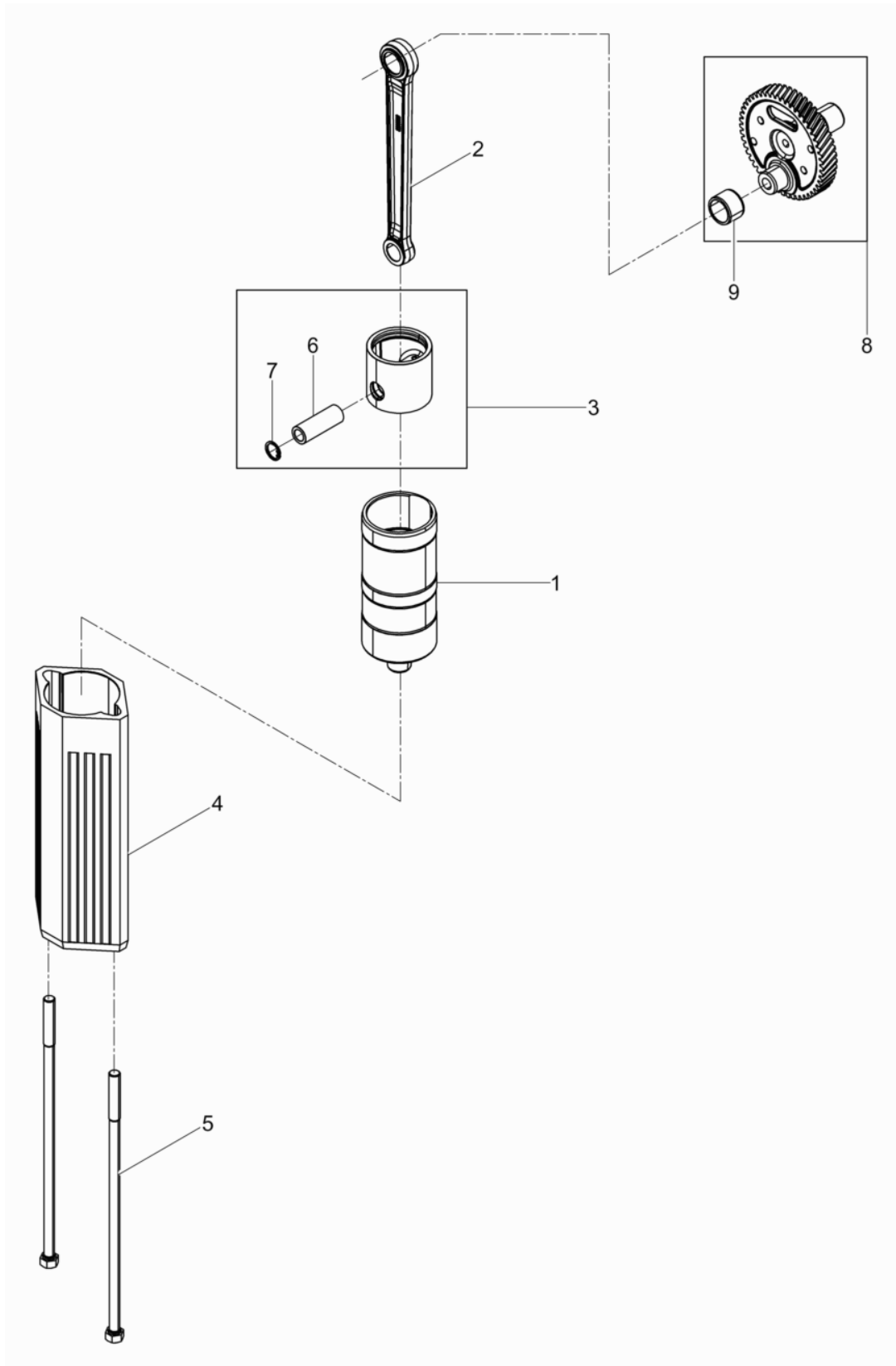

Pos. Item	Artikel Nr. Item no.	Pc.	Unit	Beschreibung Descripción	Description Description	Abm. Dim.	Norm Standard
						Drehmoment Torque	Schmierstoff Lubricant
1	5000064624	1	pc	Schlagkolben Émbolo percutor	Percussion piston Piston frappeur		
2	5000105071	1	pc	Pleuel Kpl. Biela cpl.	Connecting rod cpl. Bielle cpl.		
3	5000104649	1	pc	Führungskolben Kpl. Émbolo guía cpl.	Guide piston cpl. Piston de guidage cpl.		
4	5000063413	1	pc	Führungszylinder Cilindro de guía	Guiding cylinder Cylindre de guidage		
5	5004001193	2	pc	Dehnschraube Tornillo de dilatación	Necked down screw Vis de dilatation	M12 x 324 75Nm/55ft.lbs	
6	5000106481	2	pc	Sicherungsring Anillo de retención	Retaining ring Bague d'arrêt	20 x 1,5	DIN472
7	5000106479	1	pc	Kolbenbolzen Perno de pistón	Piston pin Axe de piston		
8	5000106403	1	pc	Kurbeltrieb Mecanismo de manivelle	Crank gear Arbre manivelle		
9	5002006602	1	pc	Innenring Anillo interior	Inner raceway Bague intérieur		

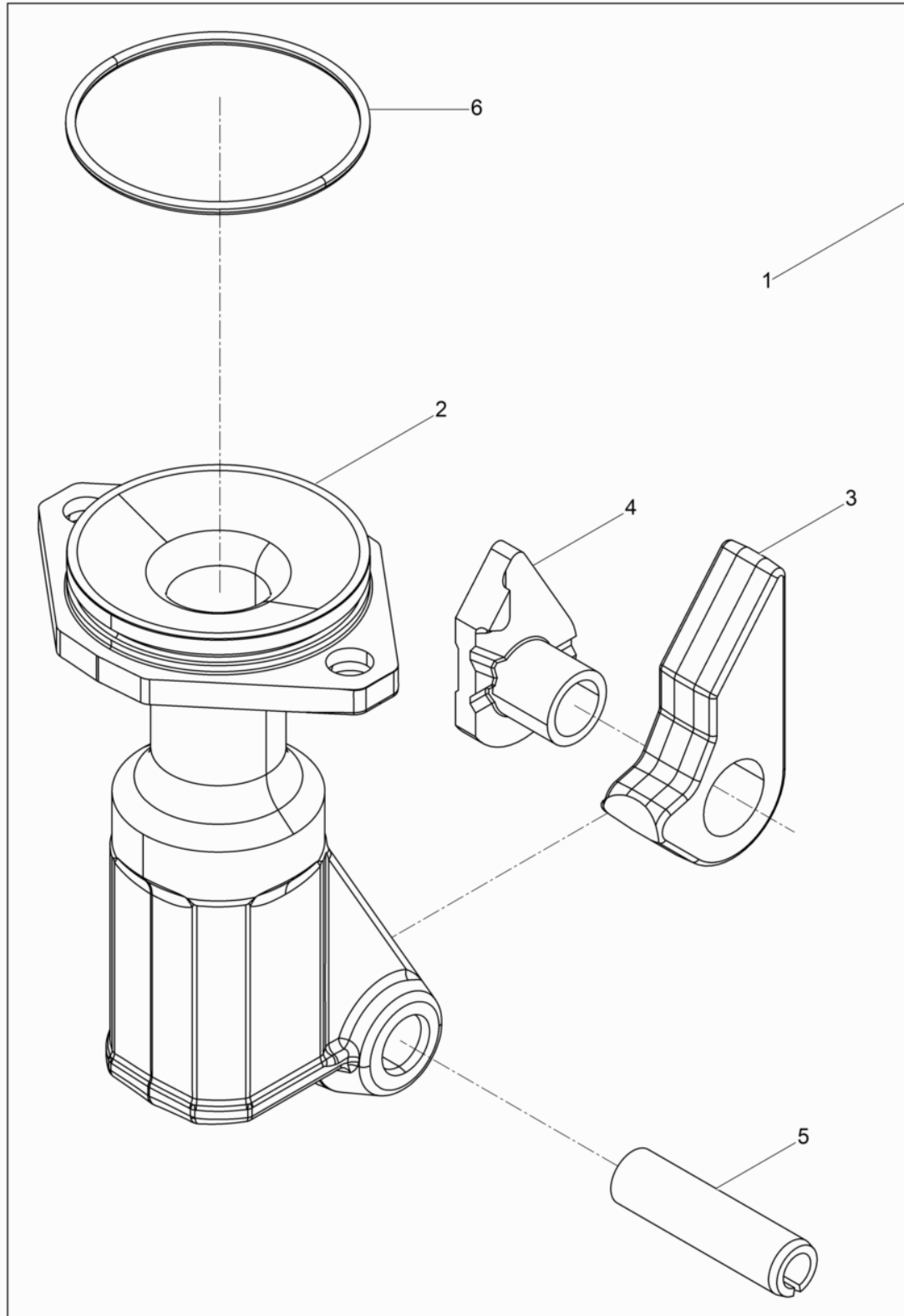

Pos. Item	Artikel Nr. Item no.	Pc.	Unit	Beschreibung Descripción	Description Description	Abm. Dim.	Norm Standard
						Drehmoment Torque	Schmierstoff Lubricant
1	5000212984	1	pc	Werkzeughalter Kpl. Porta-herramientas cpl.	Tool holder cpl. Porte-outils cpl.		
3	5000064649	1	pc	Klinke Trinquete	Catch Cliquet		
4	5000065323	1	pc	Klinkenbuchse Casquillo de trinquete	Ratchet bush Bôte de jack		
5	5000065289	1	pc	Spannstift Pasador de sujeción	Spring pin Goupille élastique	16 x 60	ISO8752
6	5002001341	1	pc	O-Ring Anillo-o	O-ring Bague-o	70 x 3	

Motor Kpl. Rs
Engine cpl. rs
Motor cpl. rs
Moteur cpl. rs

BH55RW RS 27X80

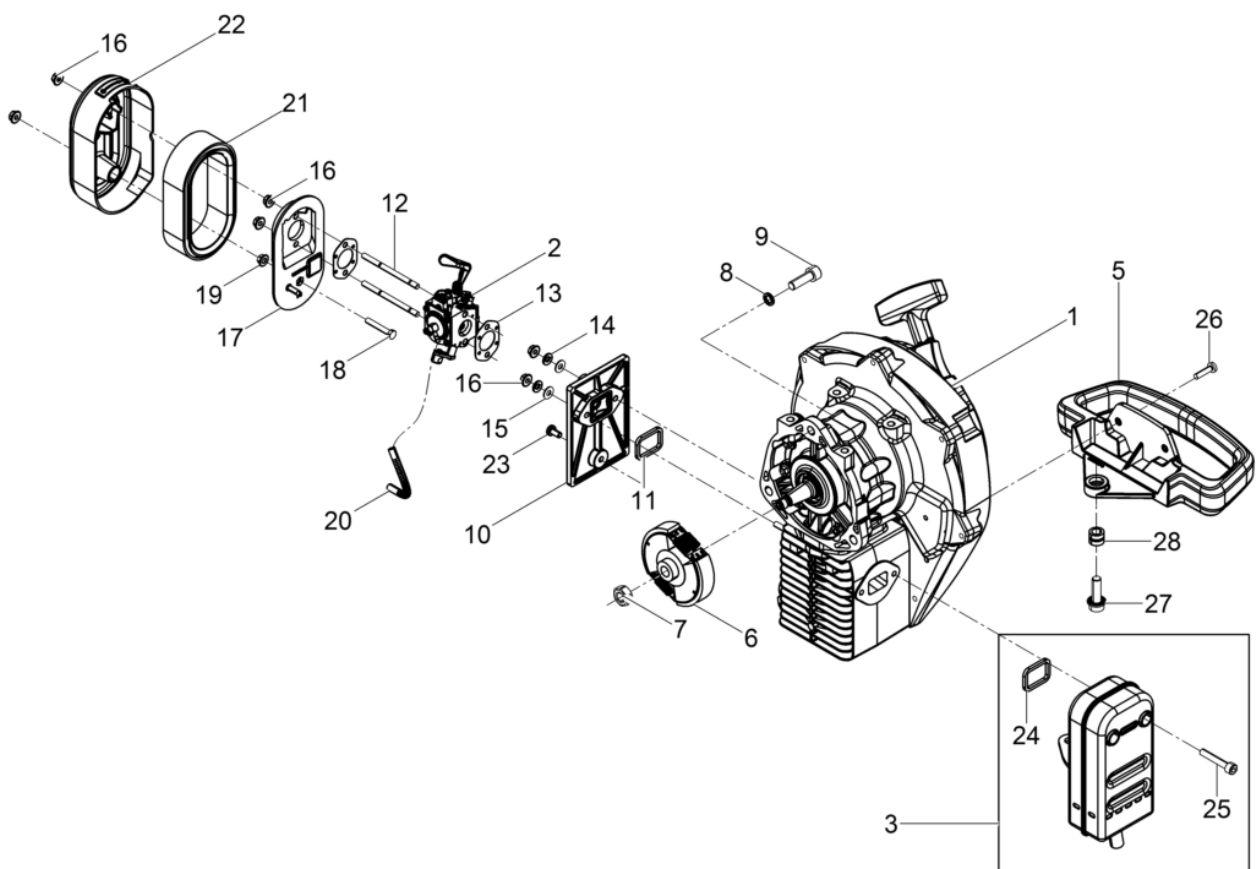

Pos. Item	Artikel Nr. Item no.	Pc.	Unit	Beschreibung Descripción	Description Description	Abm. Dim.	Norm Standard
						Drehmoment Torque	Schmierstoff Lubricant
1	5100048502	1	pc	Standardmotor Motor standard	Standard engine Moteur standard		
2	5100061744	1	pc	Vergaser Carburador	Carburetor Carburateur		
3	5100047032	1	pc	Auspufftopf Kpl. Silenciador cpl.	Exhaust cpl. Pot d'échappement cpl.		
5	5100042868	1	pc	Zusatzhandgriff Empuñadura adicional	Additional handle Poignée supplémentaire		
6	5000043595	1	pc	Fliehkraftkupplung Embrague	Centrifugal clutch Embrayage		
7	5000010883	1	pc	Sechskantmutter Tuerca hexagonal	Hexagon nut Écrou hexagonal		
8	5000012397	3	pc	Federring Arandela elástica	Lock washer Rondelle de ressort	A8	DIN127
9	5000011542	3	pc	Zylinderschraube Tornillo cilíndrico	Cheese head screw Vis à tête cylindrique		
10	5100001977	1	pc	Zwischenflansch Brida intermedia	Intermediate flange Bride intermediaire		
11	5100002961	1	pc	O-Ring Anillo-o	O-ring Bague-o	26x2	
12	5000211953	2	pc	Stiftschraube Perno prisionero	Stud Boulon		
13	5000095774	2	pc	Dichtung Junta	Seal Joint		
14	5000103212	2	pc	Scheibe Arandela	Washer Rondelle	5	DIN134
15	5000103211	2	pc	Spannscheibe Arandela elástica	Lockwasher Rondelle de ressort	5	DIN6796
16	5000047488	6	pc	Sechskantmutter Tuerca hexagonal	Hexagon nut Écrou hexagonal	M5 7Nm/5ft.lbs	DIN6923
17	5000207688	1	pc	Luftfiltergehäuse Carcasa filtro de aire	Air filter housing Carter de filtre		
18	5000011473	1	pc	Sechskantschraube Tornillo hexagonal	Hexagonal head cap screw Vis à tête hexagonale	M5 x 30 6Nm/4ft.lbs	DIN933
19	5000047488	1	pc	Sechskantmutter Tuerca hexagonal	Hexagon nut Écrou hexagonal	M5 7Nm/5ft.lbs	DIN6923
20	5000211957	1	pc	Kompensationsschlauch Manguera de la remuneración	Compensation hose Tuyau de compensation		
21	5000095711	1	pc	Luftfilter Filtro del aire	Air cleaner Filtre à air		
22	5000222499	1	pc	Luftfiltergehäusedeckel Tapa filtro de aire	Air filter cover Couvercle filtre à air		
23	5000222072	1	pc	Schraube Tornillo	Screw Vis	M 4x 10	
24	5100042769	1	pc	Auspuffdichtung Empaquetadura	Exhaust seal Joint de silencieux		
25	5100048553	2	pc	Zylinderschraube Tornillo cilíndrico	Cheese head screw Vis à tête cylindrique		
26	5100049413	2	pc	Schraube Tornillo	Screw Vis		
27	5000129420	1	pc	Zylindersicherungsschraube Tornillo de seguridad	Socket head cap screw Poignée supplémentaire		
28	5000103212	2	pc	Scheibe Arandela	Washer Rondelle	5	DIN134

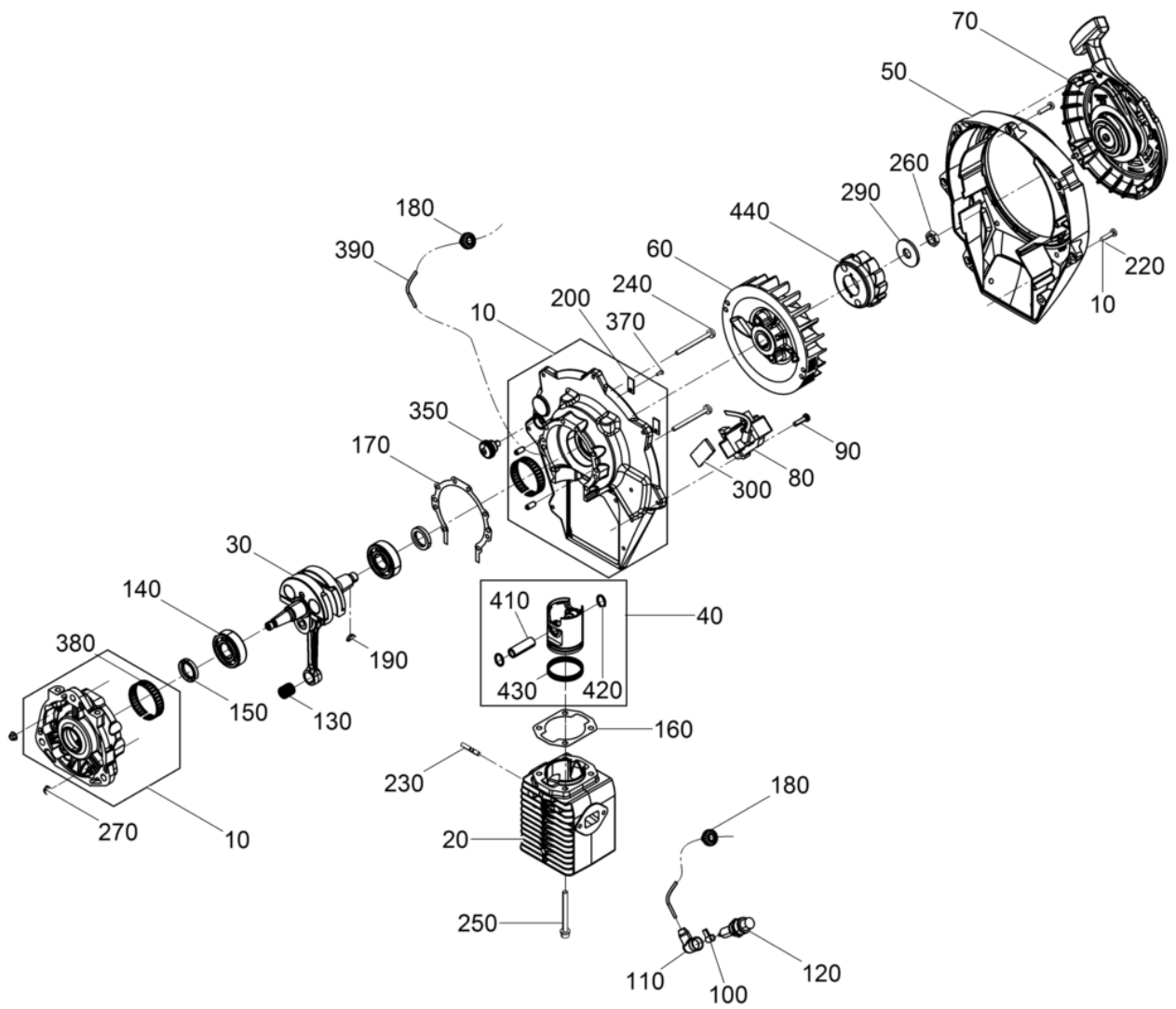

Pos. Item	Artikel Nr. Item no.	Pc.	Unit	Beschreibung Descripción	Description Description	Abm. Dim.	Norm Standard
						Drehmoment Torque	Schmierstoff Lubricant
10	5100057482	1	pc	Kurbelgehäuse Kpl. Cárter cpl.	Crankcase cpl. Carter cpl.		
20	5000213076	1	pc	Zylinder Cilindro	Cylinder Cylindre		
30	5100046448	1	pc	Kurbelwelle Kpl. Cigüeñal cpl.	Crankshaft cpl. Vilebrequin cpl.		
40	5000115324	1	pc	Kolben Pistón	Piston Piston		
50	5100042845	1	pc	Gebläsedeckel Tapa de ventilador	Fan hood Couvercle du sys. de vent.		
60	5100042865	1	pc	Lüfterrad Rueda del ventilador	Fan wheel Roue d'aeration		
70	5100067030	1	pc	Reversierstarter Kpl. Starter reversible cpl.	Recoil starter cpl. Démarrreur réversible cpl.		
80	5000126090	1	pc	Zündanlage Kpl. Instalación de encendido cpl.	Magneto armature cpl. Installation d'allumage cpl.		
100	5000153124	1	pc	Zündkerzenstecker Capuchón de bujía	Spark plug (terminal) cap Capuchon de bougie		
110	5000153125	1	pc	Zündkerzenstecker Capuchón de bujía	Spark plug (terminal) cap Capuchon de bougie		
120	5000172332	1	pc	Zündkerze Bujía	Spark plug Bougie		
130	5000034835	1	pc	Nadelkranz Rodamiento de agujas	Needle bearing Roulement à aiguilles		
140	5100065070	2	pc	Rillenkugellager Rodamiento de bolas	Grooved ball bearing Roulement à billes		
150	5100006052	2	pc	Wellendichtring Sello del eje	Shaft seal Bague d'étanchéité		
160	5100025323	1	pc	Zylinderdichtung Junta del cilindro	Cylinder gasket Joint de cylindre		
170	5100025322	1	pc	Kurbelgehäusedichtung Junta	Gasket Joint		
180	5100060760	2	pc	Kabeldurchführung Conducto de cable	Cable passage Passage de câble		
190	5000010388	1	pc	Scheibenfeder Chaveta woodruff	Woodruff key Clavette woodruff	3 x 5	DIN6888
200	5000045906	2	pc	Halter Retenedor	Retainer Arrêtoir		
220	5100049413	10	pc	Schraube Tornillo	Screw Vis		
230	5100027617	2	pc	Stiftschraube Perno prisionero	Stud Boulon	M5x20	
240	5000215365	8	pc	Zylinderschraube Tornillo cilíndrico	Cheese head screw Vis à tête cylindrique	M 5x 60	
250	5000095917	4	pc	Zylinderschraube Tornillo cilíndrico	Cheese head screw Vis à tête cylindrique	M6 x 60	
260	5000045914	1	pc	Sechskantmutter Tuerca hexagonal	Hexagon nut Écrou hexagonal	M12 x 1,5	ISO8675
270	5000183750	8	pc	Sechskantmutter Tuerca hexagonal	Hexagon nut Écrou hexagonal		
290	5000010376	1	pc	Scheibe Arandela	Flat washer Rondelle	A13	DIN9021
300	5000164990	1	pc	Schaumstoff Materia espumoso	Foam Mousse		
350	5002007007	1	pc	Kurzschlußknopf Interruptor de botón	Push button switch Interrupteur à poussoir		

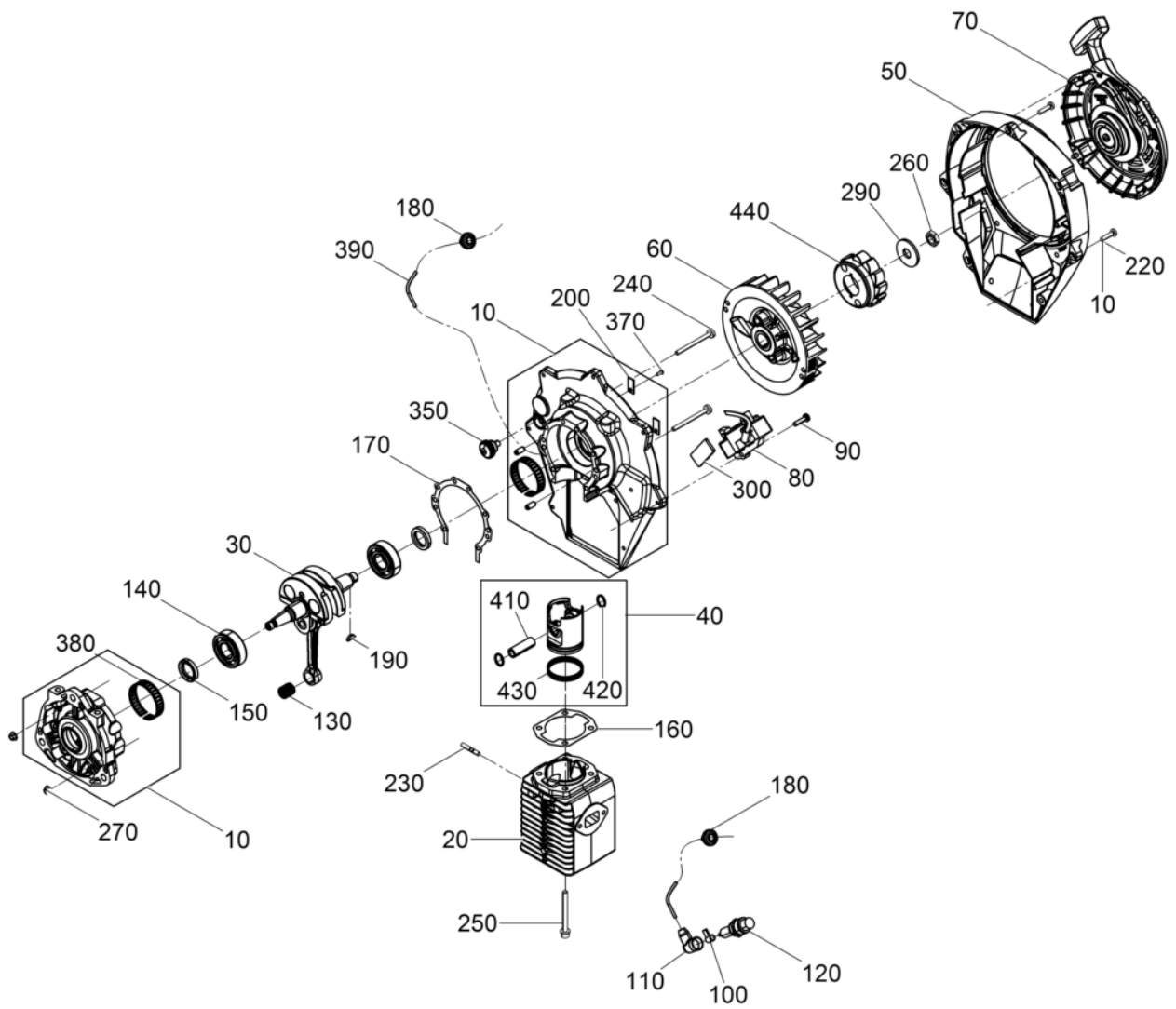

Pos. Item	Artikel Nr. Item no.	Pc.	Unit	Beschreibung Descripción	Description Description	Abm. Dim.	Norm Standard
						Drehmoment Torque	Schmierstoff Lubricant
360	5000114746	1	pc	Aufkleber Calcomania	Label Autocollant		
370	5100027591	1	pc	Blindniet Remache ciego	Blind rivet Rivet dobturation	3x8	
380	5100041830	2	pc	Toleranzhülse Manguito	Sleeve Manchon		
390	5100025551	1	pc	Kraftstoffschlauch Manguera de combustible	Fuel hose Tuyau à essence		
410	5000012199	1	pc	Kolbenbolzen Pasador de pistón	Piston pin Axe de piston		
420	5000012257	2	pc	Drahtsprengring Anillo de retención	Retaining ring Bague d'arrêt	A12	DIN73123
430	5000045904	2	pc	Kolbenring Aro de pistón	Piston ring Segment de piston	45 x 1,5	DIN70910
440	5100065739	1	pc	Einsatz (Lüfterrad) Inserto (rueda del ventilador)	Insert (fan wheel) Insertion (roue d'aeration)		

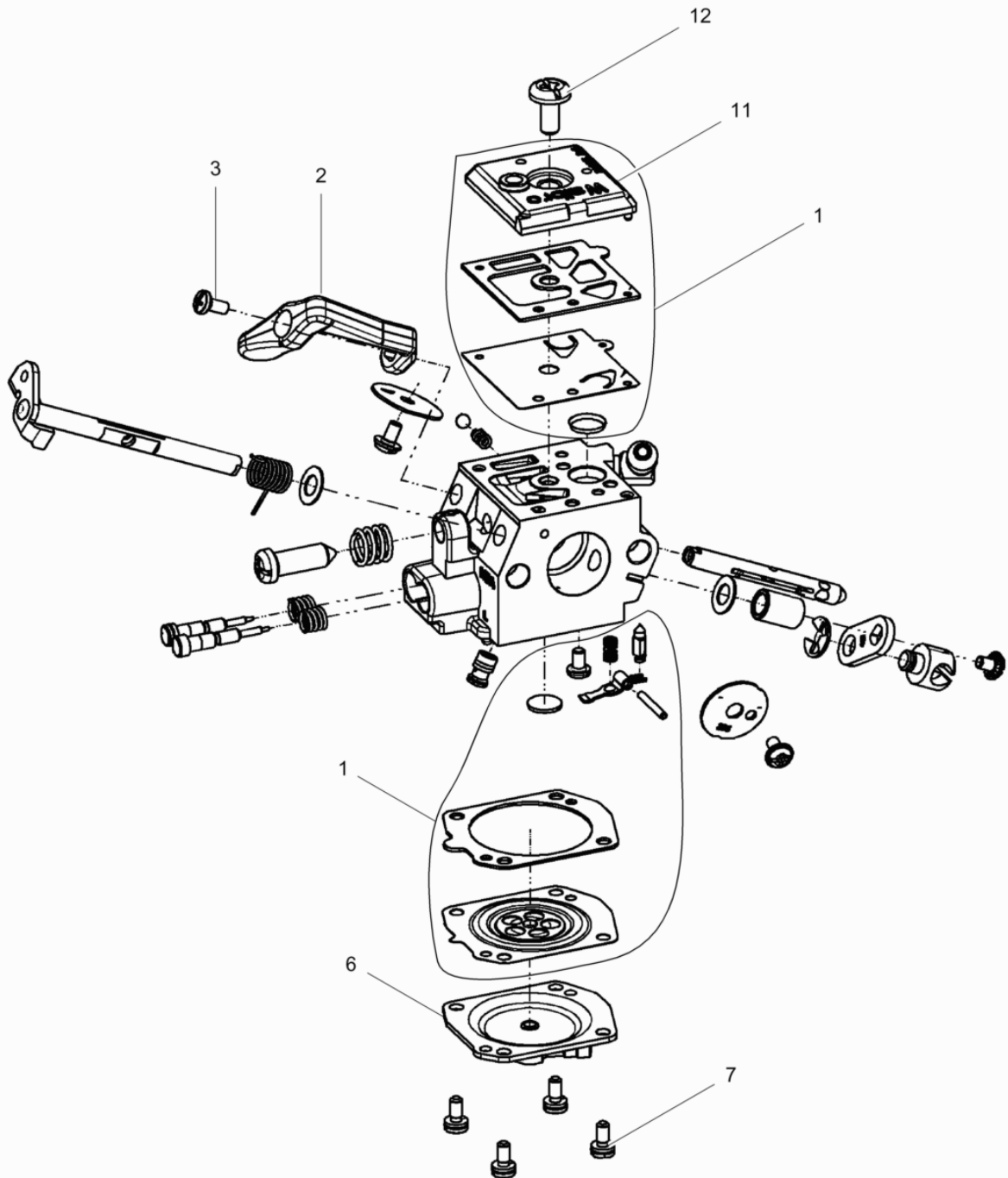

Pos. Item	Artikel Nr. Item no.	Pc.	Unit	Beschreibung Descripción	Description Description	Abm. Dim.	Norm Standard
						Drehmoment Torque	Schmierstoff Lubricant
1	5000222003	1	pc	Vergaser Reparaturatz Carburador juego de reparaci3nador	Carburetor repair kit Carburateur jeu de r3paration		
2	5000222004	1	pc	Chokehebel Palanca estranguladora	Choke control lever Lever d'3trangleur		
3	5000222005	1	pc	Schraube Tornillo	Screw Vis		
6	5000222008	1	pc	Deckel Cubierta	Cover Couvercle		
7	5000222009	4	pc	Schraube Tornillo	Screw Vis		
11	5000222013	1	pc	Deckel Cubierta	Cover Couvercle		
12	5000222014	1	pc	Schraube Tornillo	Screw Vis		

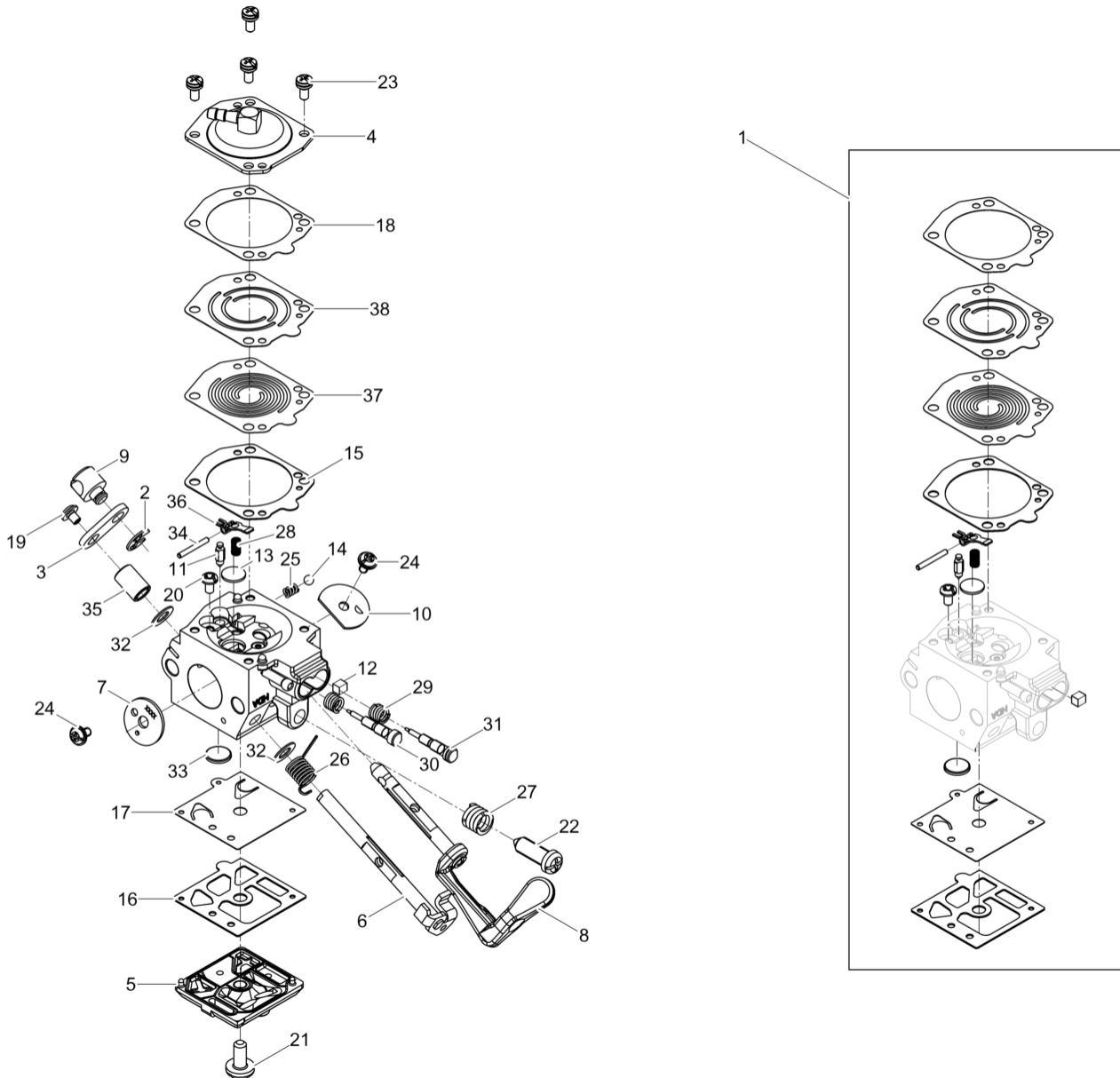

Pos. Item	Artikel Nr. Item no.	Pc.	Unit	Beschreibung Descripción	Description Description	Abm. Dim.	Norm Standard
						Drehmoment Torque	Schmierstoff Lubricant
1	5100068443	1	pc	Reparaturpaket Vergaser HDA354 Carburador juego de reparación hda354	Carburetor repair kit hda354 Carbureteur jeu de réparation		
2	5100069857	1	pc	Sicherungsring Anillo de retención	Retaining ring Bague d'arrêt		
3	5100069858	1	pc	Gashebel Acelerador	Throttle lever Manette de gaz		
4	5100069859	1	pc	Deckel Tapa	Cover Couvercle		
5	5000222013	1	pc	Deckel Cubierta	Cover Couvercle		
6	5100069860	1	pc	Gasreglerwelle Eje de mariposa compl.	Throttle shaft cpl. Arbre des gaz compl.		
7	5100069861	1	pc	Gasreglerklappe Válvula de estrangulación	Throttle valve Étrangleur		
8	5100069841	1	pc	Chokehebel Palanca de cebador	Choke lever Tirette de starter		
9	5100069842	1	pc	Hülse Collar	Collar Douille		
10	5100069844	1	pc	Drosselklappe Válvula de mariposa	Throttle flap Clapet d'entranglement		
11	5000182769	1	pc	Einlaßventil Válvula de admisión	Inlet valve Soupape d'admission		
12	5000176061	1	pc	Düse Tobera	Nozzle Ajutage		
13	5000182772	1	pc	Stopfen Tapón	Plug Bouchon		
14	5000175317	1	pc	Kugel Bola	Ball Bille	1/8in OD	
15	5100069848	1	pc	Dichtung Junta	Seal Joint		
16	5000182759	1	pc	Dichtung Junta	Gasket Joint		
17	5000182760	1	pc	Membran Kpl. Diafragma compl.	Diaphragm cpl. Diafragma compl.		
18	5100069849	1	pc	Dichtung Junta	Seal Joint		
19	5000175315	1	pc	Schraube Tornillo	Screw Vis		
20	5000222015	1	pc	Schraube Tornillo	Screw Vis		
21	5000175299	1	pc	Flachkopfschraube Tornillo de cabeza de cono achatado	Pan head screw Vis ber		
21	5000182757	1	pc	Flachkopfschraube Tornillo de cabeza de cono achatado	Pan head screw Vis ber		
22	5000222009	1	pc	Schraube Tornillo	Screw Vis		
23	5000222009	4	pc	Schraube Tornillo	Screw Vis		
24	5000175305	2	pc	Schraube Tornillo	Screw Vis		
25	5000175318	1	pc	Chokefeder Resorte estrangulador	Choke spring Ressort - étrangleur		
26	5000175311	1	pc	Feder Resorte	Spring Ressort		

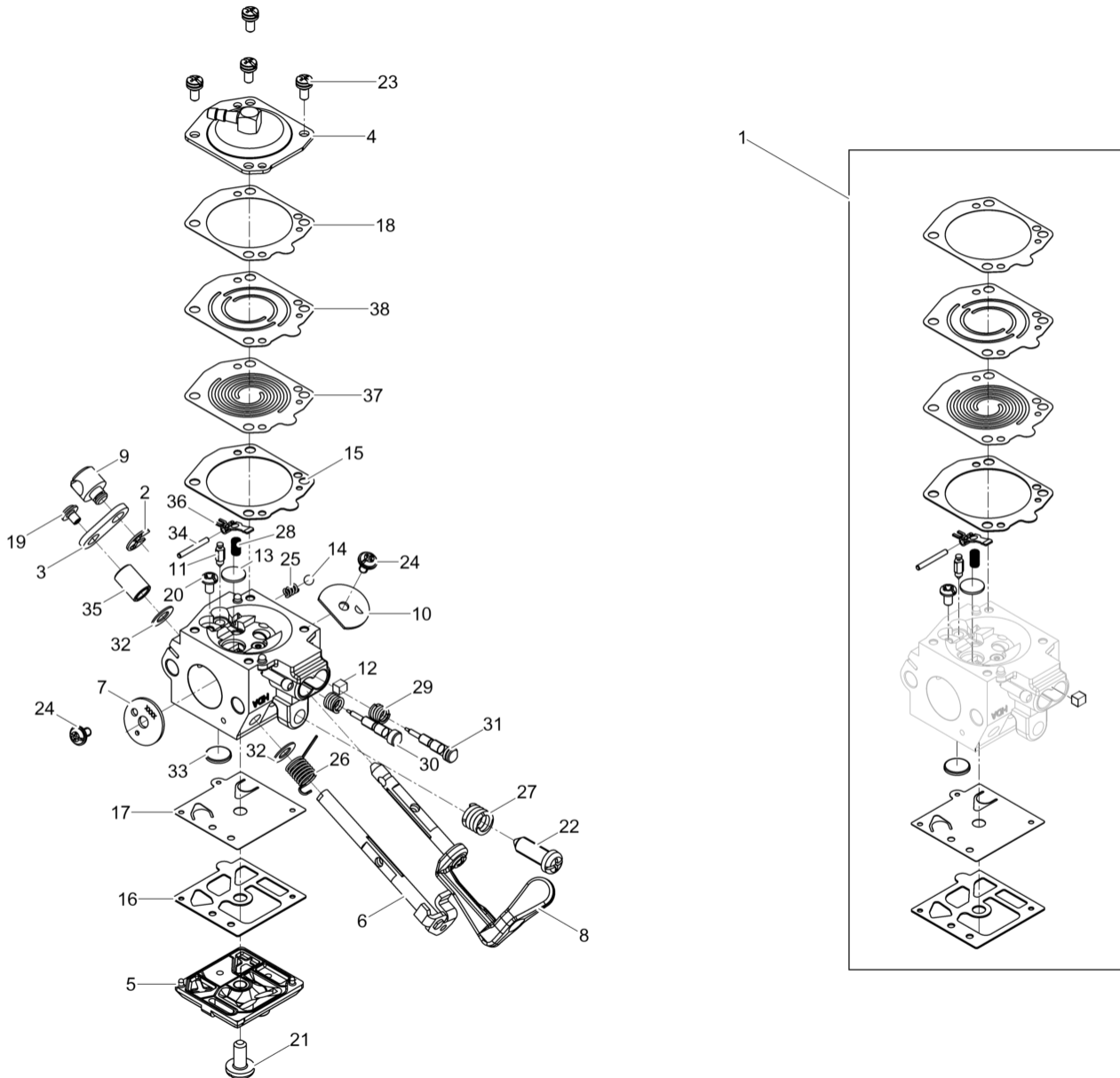

Pos. Item	Artikel Nr. Item no.	Pc.	Unit	Beschreibung Descripción	Description Description	Abm. Dim.	Norm Standard
						Drehmoment Torque	Schmierstoff Lubricant
27	5000182778	2	pc	Feder Resorte	Spring Ressort		
28	5000175306	1	pc	Feder Resorte	Spring Ressort		
29	5100069850	2	pc	Feder Resorte	Spring Ressort		
30	5100069845	1	pc	Nadelventil Válvula de aguja	Needle valve Soupape à pointeau		
31	5100069846	1	pc	Nadelventil Válvula de aguja	Needle valve Soupape à pointeau		
32	5000175300	2	pc	Scheibe Arandela	Washer Rondelle		
33	5000182761	1	pc	Sieb Tamiz	Screen Tamis		
34	5000182771	1	pc	Stift Pasador	Pin Goupille		
35	5000182764	1	pc	Abstandsstück Espaciador	Spacer Entretoise		
35	5100028372	1	pc	Abstandsstück Espaciador	Spacer Entretoise		
36	5100069843	1	pc	Hebel Palanca	Lever Levier		
37	5100069854	1	pc	Membran Membrana	Diaphragm Membrane		
38	5100069851	1	pc	Membran Membrana	Diaphragm Membrane		

Reversierstarter Kpl. WM80c
Recoil starter cpl. wm80c
Starter reversible cpl. wm80c
Démarrreur réversible cpl.

BH55RW RS 27X80

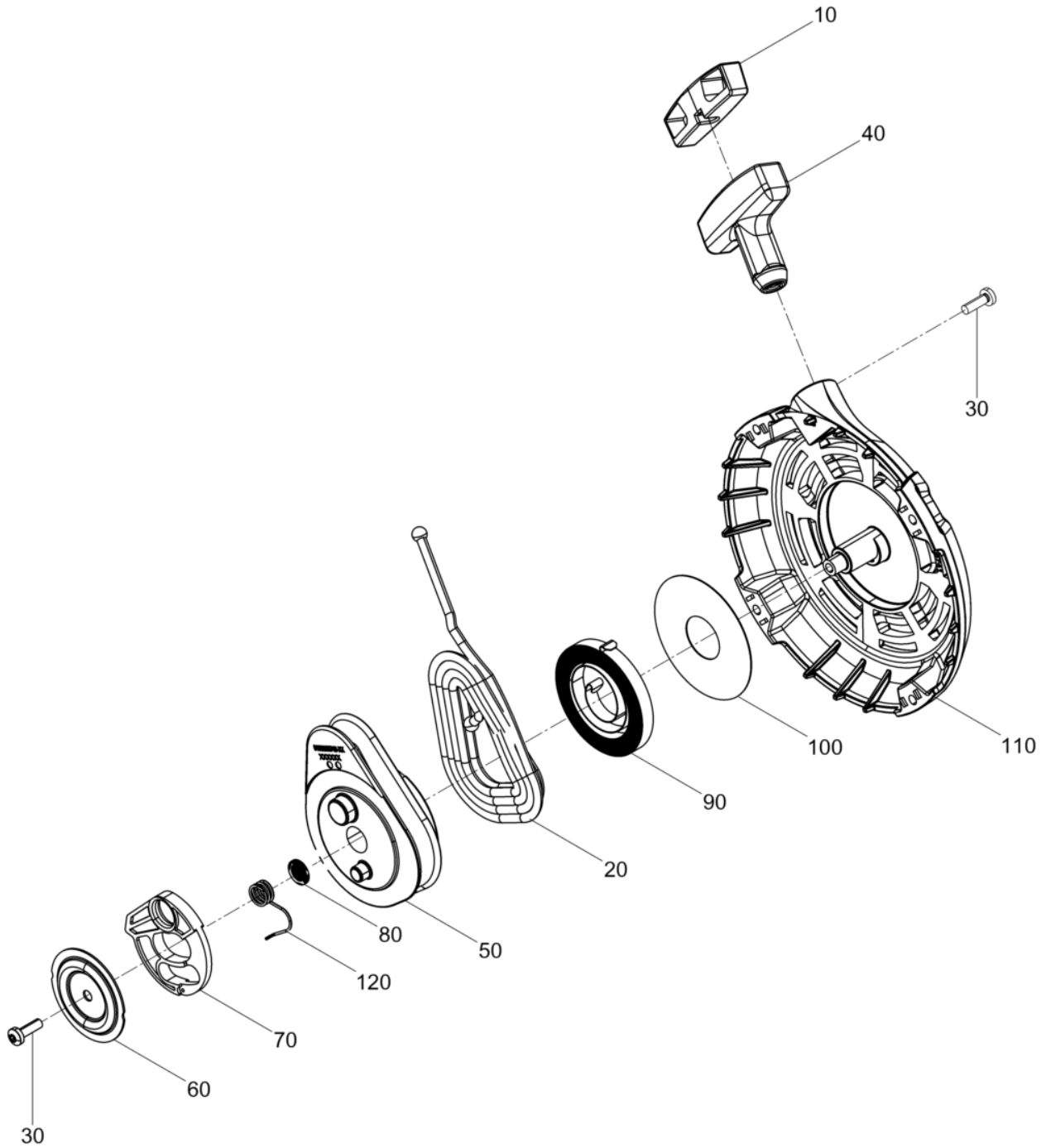

Pos. Item	Artikel Nr. Item no.	Pc.	Unit	Beschreibung Descripción	Description Description	Abm. Dim.	Norm Standard
						Drehmoment Torque	Schmierstoff Lubricant
10	5000059891	1	pc	Halter Retenedor	Retainer Arrêtoir		
20	5000104548	1	pc	Starterseil Cuerda de arranque	Starter rope Corde de starter		
30	5100047080	5	pc	Schraube M 5X 16 Tornillo	Screw Vis		
40	5000059890	1	pc	Anwerfgriff Empuñadura del arranque	Starter handle Poignée du lanceur		
50	5100065740	1	pc	Seilscheibe Polea para cuerda	Rope disc Poulie de démarrage		
60	5000047997	1	pc	Führungsscheibe Tapa	Cover Couvercle		
70	5000047998	1	pc	Klinke Trinquete	Ratchet (pawl) Cliquet		
80	5000048062	1	pc	Scheibe Arandela	Washer Rondelle		
90	5100065737	1	pc	Rückholfeder Resorte de retorno	Return spring Ressort de rappel		
100	5100065738	1	pc	Anlaufscheibe Arandela tope	Check disc Disque		
110	5100065741	1	pc	Startergehäuse Caja del arrancador	Starter housing Carter de démarreur		
120	5000048059	1	pc	Drehfeder Resorte	Spring Ressort		

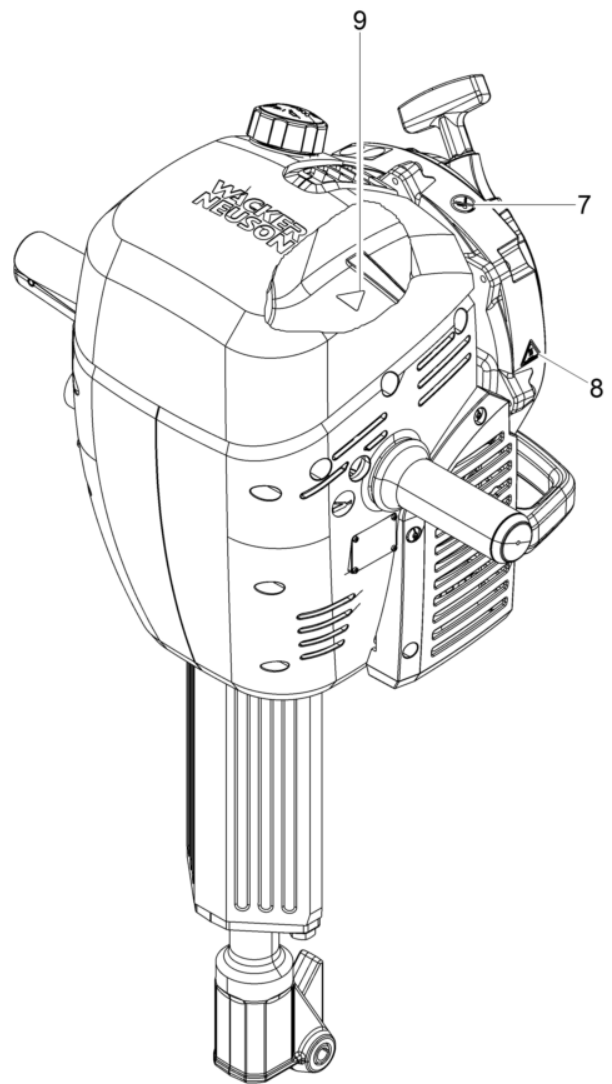
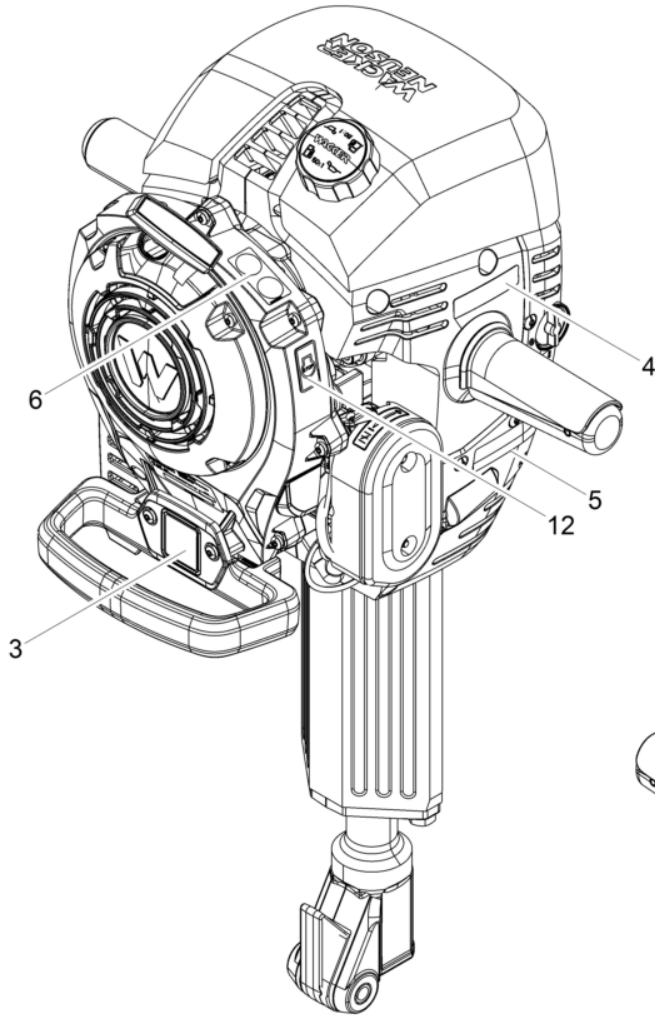

Pos. Item	Artikel Nr. Item no.	Pc.	Unit	Beschreibung Descripción	Description Description	Abm. Dim.	Norm Standard
						Drehmoment Torque	Schmierstoff Lubricant
3	5000064925	1	pc	Aufkleber-Schalleistungspegel Etiqueta autoadhesiva-nivel de potencia acúëstica	Decal-sound power level Autocollante-niveau sonore		
4	5100002995	1	pc	Aufkleber Typenbezeichnung Tipo etiqueta autoadhesiva	Type label Autocollant de type		
5	5000222089	1	pc	Aufkleber Logo Calcomania insignia	Label logo Autocollant logo		
6	5000219174	1	pc	Aufkleber Calcomanias	Labels Autocollants		
7	5000219180	1	pc	Aufkleber Calcomanias	Labels Autocollants		
8	5000219114	1	pc	Aufkleber Calcomanias	Labels Autocollants		
9	5000219177	1	pc	Aufkleber Calcomanias	Labels Autocollants		
12	5000114746	1	pc	Aufkleber Calcomania	Label Autocollant		

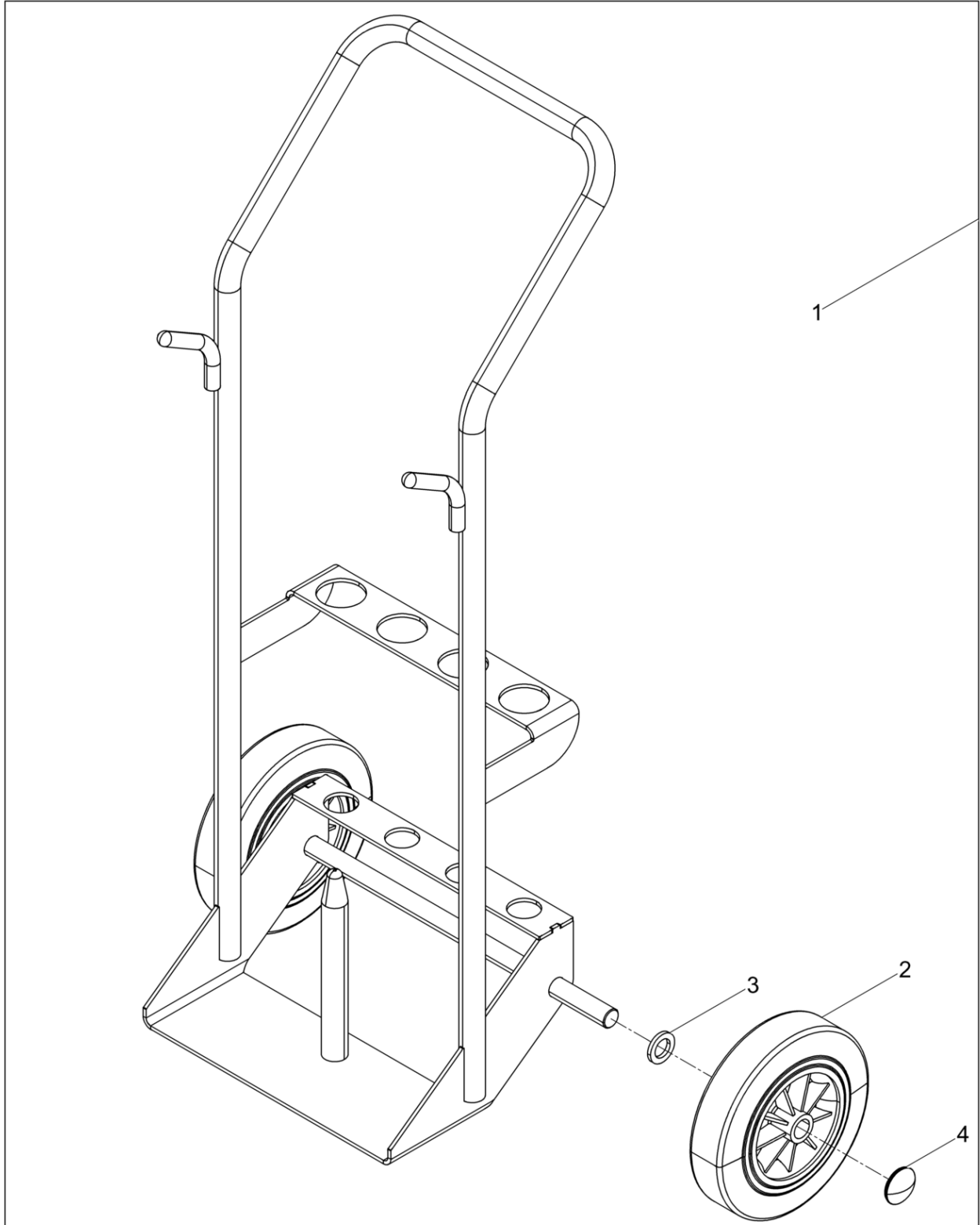

Pos. Item	Artikel Nr. Item no.	Pc.	Unit	Beschreibung Descripción	Description Description	Abm. Dim.	Norm Standard
						Drehmoment Torque	Schmierstoff Lubricant
1	5000208699	1	pc	Transportwagen Carro transportación	Cart transportation Voiturette transport		
2	5000201653	2	pc	Rad Rueda	Wheel Roue	200x50	
3	5000010662	2	pc	Scheibe Arandela	Flat washer Rondelle	20	DIN1440
4	5000039752	2	pc	Starlockkappen Tapa	Cap Chapeau	20 mm	

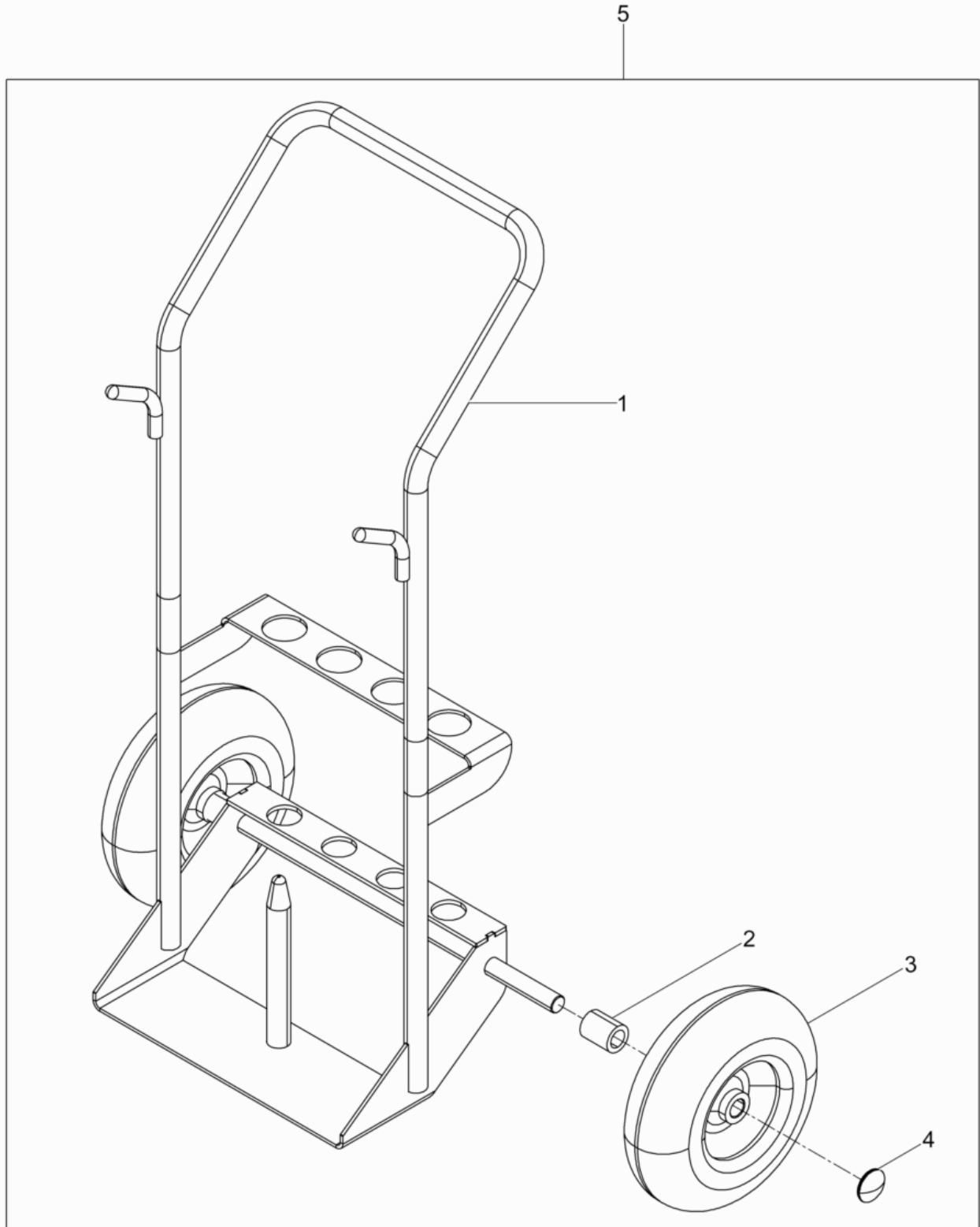

BH55RW RS 27X80**Transportwagen Kpl.
Cart transportation cpl.
Carro transportación cpl.
Voiturette transport cpl.**

Pos. Item	Artikel Nr. Item no.	Pc.	Unit	Beschreibung Descripción	Description Description	Abm. Dim.	Norm Standard
						Drehmoment Torque	Schmierstoff Lubricant
1	5000215341	1	pc	Transportwagen Carro transportación	Cart transportation Voiturette transport		
2	5000215345	2	pc	Hülse Collar	Collar Douille		
3	5002003396	2	pc	Rad Rueda	Tire Roue		
4	5000039752	2	pc	Starlockkappen Tapa	Cap Chapeau	20 mm	
5	5000215340	1	pc	Transportwagen Carro transportación cpl.	Cart transportation cpl. Voiturette transport cpl.		





**WACKER
NEUSON**