



**WACKER
NEUSON**

Ersatzteilkatalog
Spare parts catalog
Catálogo de piezas de repuesto
Catalogue de pièces de rechange

**Aufbruchhammer
Demolition breaker
Martillo rompedor
Marteau piqueur**

BH 65 32X160



Type	BH 65 32X160
Material Number	5100004036
Version	103
Language	de en es fr



www.wackerneuson.com

Copyright © 03.2023
Wacker Neuson Produktion GmbH & Co. KG
Printed in Germany.
All rights reserved.

Ein Typenschild mit Typ, Artikelnummer, Version und Maschinen-Nummer ist an jedem Gerät angebracht. Die Daten von diesem Schild bitte notieren, damit sie auch bei Verlust oder Beschädigung des Schildes noch vorhanden sind. Der Typ, die Artikelnummer, die Versions-Nummer und die Maschinen-Nummer sind bei der Ersatzteilbestellung oder Nachfragen bezüglich Service-Informationen stets erforderlich.

Bei den in den Ersatzteillisten fettgedruckten Nummern handelt es sich um empfohlene Ersatzteile. Dies bedeutet, daß diese Teile bei normalen Anwendungsbedingungen natürlicher Abnutzung ausgesetzt sind und gelegentlich ersetzt oder überarbeitet werden müssen. Es wird geraten, diese Teile auf Lager bereit zu haben, um für Service-Arbeiten an diesem Gerät vorbereitet zu sein. Lagerbestände für diese und andere Teile, welche für ausgiebigere Reparaturarbeiten benötigt werden, können je nach Service-Gewohnheiten der einzelnen Kunden variieren.

Die Nummern meines Gerätes sind:

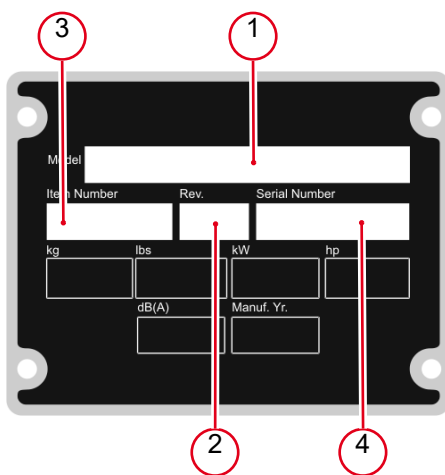

1. Typ
2. Version
3. Artikel-Nr.
4. Maschinen-Nr.

Umrechnungstabelle

Volumeneinheit	
1 ml	0.034 US fl.oz.
1 l	0.260 gal
Längeneinheit	
1 mm	0.039 in
1 m	3.280 ft
Gewicht	
1 kg	2.200 lbs
1 g	0.035 oz
Geschwindigkeit	
1 km/h	0.620 mph
Drehmoment	
1 Nm	0.740 ft.lbs

A nameplate listing the Model Number, Item Number, Revision, and Serial Number is attached to each unit. Please record the information found on this plate so it will be available should the nameplate become lost or damaged. When ordering parts or requesting service information, you will always be asked to specify the model, item number, revision number, and serial number of the unit.

Part Numbers appearing in boldface type are recommended spare parts. This means that these parts are subject to wear under normal operating conditions and may require periodic service or replacement. It is recommended that these items be stocked to meet the expected service requirements of this model. Actual stocking quantities of these and other parts used in more extensive repairs will depend on the service practices of each customer.

My machine's numbers are:

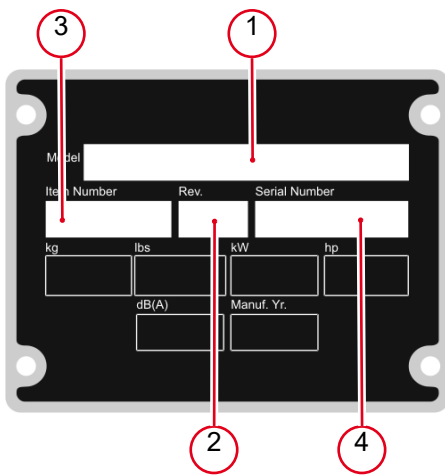

- 1. Model
- 2. Revision
- 3. Item No.
- 4. Serial No.

Conversion table

Volume unit	
1 ml	0.034 US fl.oz.
1 l	0.260 gal
Unit of length	
1 mm	0.039 in
1 m	3.280 ft
Weight	
1 kg	2.200 lbs
1 g	0.035 oz
Speed	
1 km/h	0.620 mph
Torque	
1 Nm	0.740 ft.lbs

Una placa de identificación con el modelo, número de referencia, nivel de revisión y número de serie ha sido añadida en cada máquina. Favor de anotar los datos en la placa en caso de que la placa de identificación sea destruida o perdida. En todos los pedidos para repuestos necesita siempre el modelo, el número de referencia, el nivel de revisión y el número de serie de la máquina en cuestión.

Los números de partes en negritas en las Listas Ilustradas de Partes son los repuestos recomendados, esto quiere decir que estas partes se desgastarán bajo circunstancias de funcionamiento normales y pueden requerir servicio periódico o su reemplazo. Se recomienda que el cliente mantenga un abastecimiento adecuado de estas partes para poder satisfacer la demanda requerida por el servicio a la máquina. La cantidad de repuestos que el cliente necesitará para reparaciones dependerá de la póliza de servicio de cada cliente.

Los números de mi máquina son:

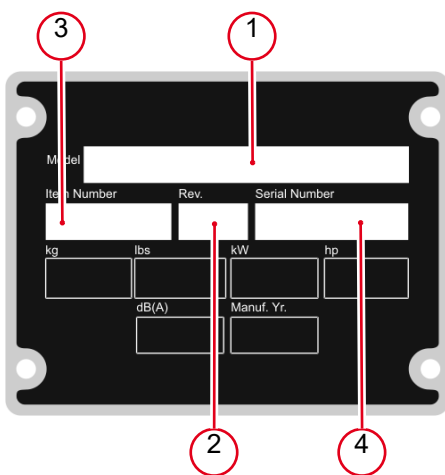

1. Modelo
2. Nivel de revisión
3. Número de referencia
4. Número de Serie

Tabla de conversión

Unidad de volumen	
1 ml	0.034 US fl.oz.
1 l	0.260 gal
Unidad de longitud	
1 mm	0.039 in
1 m	3.280 ft
Peso	
1 kg	2.200 lbs
1 g	0.035 oz
Velocidad	
1 km/h	0.620 mph
Par de apriete	
1 Nm	0.740 ft.lbs

Une plaque signalétique mentionnant le modèle, le numéro de référence, le niveau de revision et le numéro de série est fixée sur chaque machine. Veuillez noter les informations relevées sur cette plaque de façon à ce qu'elles soient toujours disponibles si la plaque signalétique venait à être perdue ou endommagée. Lorsque vous commandez des pièces détachées ou vous sollicitez des informations après-vente, on vous demandera toujours de préciser le modèle, le numéro de référence, le niveau de revision et le numéro de série de la machine.

Les numéros de pièces imprimés en caractères gras dans les Listes des Pièces Détachées de ce manuel sont les pièces détachées recommandées par la Wacker. Cela veut dire que ces pièces sont sujettes à usure dans des conditions de travail normales et peuvent nécessiter de l'entretien ou leur remplacement. Nous recommandons que vous disposez d'un stock de ces pièces pour pouvoir satisfaire la demande d'entretien de cette machine. Le client doit décider lui-même de la quantité exacte de pièces de rechange qu'il disposera dans ses stocks.

Les numéros de ma machine son :

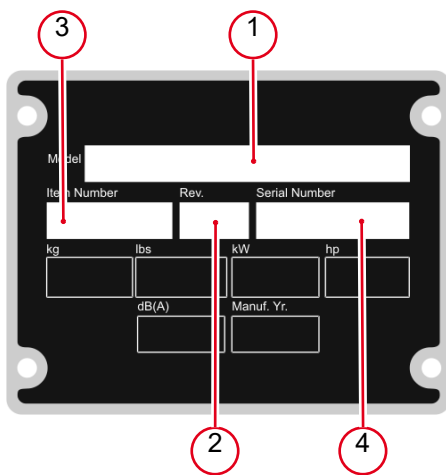

1. Typ
2. Version
3. Artikel-Nr.
4. Maschinen-Nr.

Table de conversion

Unité de volume	
1 ml	0.034 US fl.oz.
1 l	0.260 gal
Unité de longueur	
1 mm	0.039 in
1 m	3.280 ft
Poids	
1 kg	2.200 lbs
1 g	0.035 oz
Vitesse	
1 km/h	0.620 mph
Couple de serrage	
1 Nm	0.740 ft.lbs

Verkleidung Kpl.
Hood cpl.
Revestimiento cpl.
Revetement cpl. 10

Tank Kpl.
Tank cpl.
Tanque cpl.
Réservoir cpl. 12

Kurbelgehäuse
Crankcase
Cárter
Carter 14

Schlagwerk-Führungszylinder
Striking mechanism-cylinder guide
Mecanismo llamativo-cilindro de guía
Mécanisme saisissant-cylindre 16

Werkzeughalter
Tool holder
Porta-herramientas
Porte-outils 18

Motor Kpl.
Engine complete
Motor compl.
Moteur compl. 20

Benzinmotor
Gas engine
Motor a gasolina
Moteur à essence 22

Membranvergaser
Diaphragm carburetor
Carburador a membrana
Carburateur à membrane 26

Starter
Starter
Arrancador
Démarreur 28

Aufkleber
Labels
Calcomanías
Autocollants 30

Service
Service
Servicio
Service

Wartungspaket BH 55, 65
Maintenance set bh 55, 65
Juego para mantenimientobh 55, 65
Jeu d'entretien bh 55, 65 32



Reparaturpaket WM 80 Kolbenring Repair kit wm 80 piston ring Juego de reparación wm 80 aro de pistón Jeu de réparation wm 80	34
---	----

Reparaturpaket WM 80 Kat Zylinder Mit Kolben Repair kit wm 80 catcylinder with piston Juego de reparación wm 80 catcilindro con pistón Jeu de réparation wm 80	36
---	----

Reparaturpaket WM 80 Kolben Repair kit wm 80 piston Juego de reparación wm 80 pistón Jeu de réparation wm 80 piston	38
--	----

Zubehör
Accessories
Accesorios
Accessoires

Transportwagen Kpl. Cart transportation cpl. Carro transportación cpl. Voiturette transport cpl.	40
--	----

Transportwagen Kpl. Cart transportation cpl. Carro transportación cpl. Voiturette transport cpl.	42
--	----



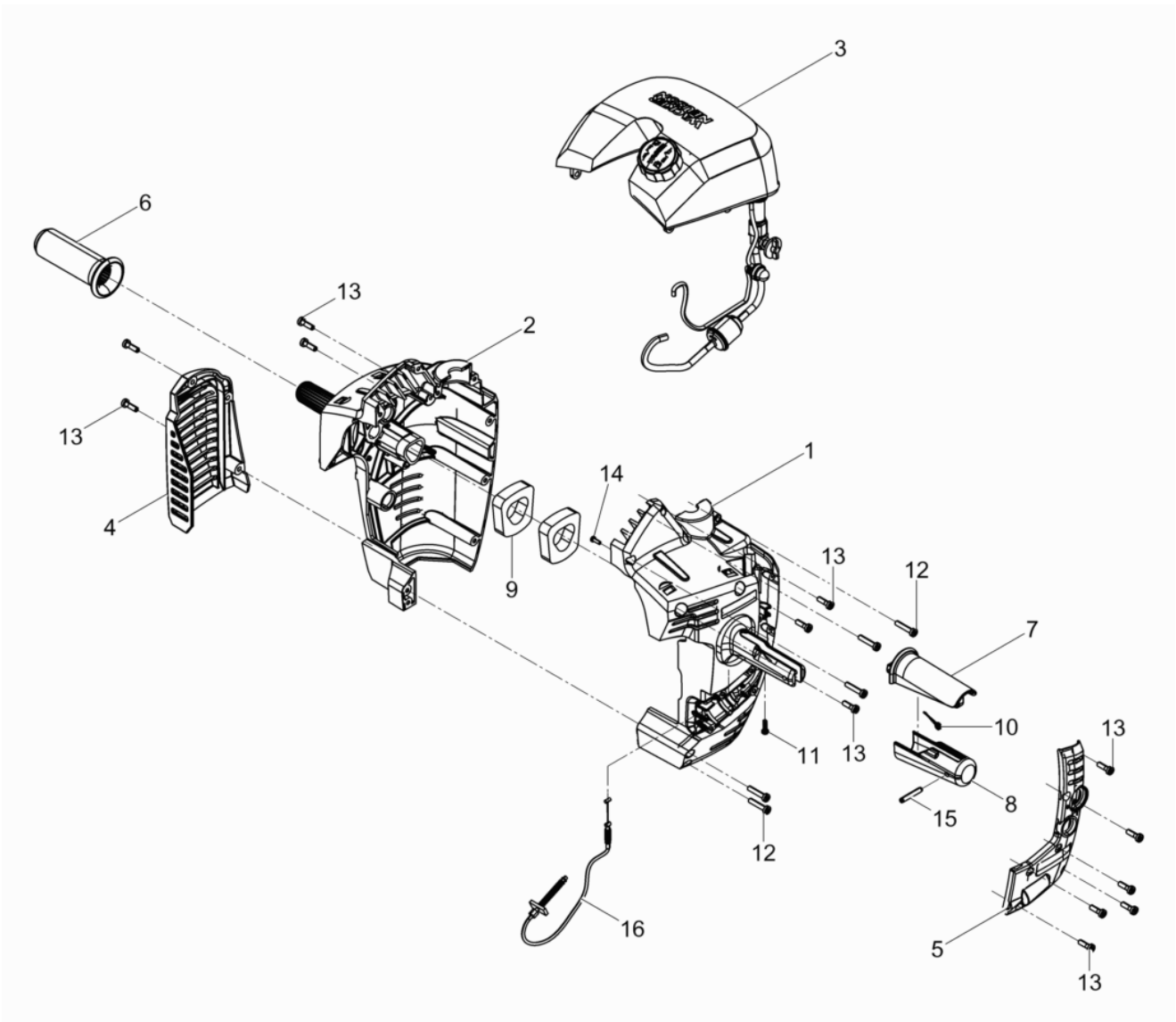

Pos. Item	Artikel Nr. Item no.	Pc.	Unit	Beschreibung Descripción	Description Description	Abm. Dim.	Norm Standard
						Drehmoment Torque	Schmierstoff Lubricant
1	5100025242	1	pc	Verkleidung Vergaserseitig Revestimiento lado carburador	Hood carburetor side Revetement part carburateur		
2	5100025243	1	pc	Verkleidung Auspuffseitig Revestimiento lado escape	Hood exhaust side Revetement part échappement		
3	5100036131	1	pc	Tank Kpl. Tanque cpl.	Tank cpl. Réservoir cpl.		
4	5000213533	1	pc	Abdeckung Cobertura	Covering Couvercle		
5	5100025241	1	pc	Deckel Tapa	Cover Couvercle		
6	5000095437	1	pc	Handgriff Empuñadura	Handle Poignée		
7	5000222523	1	pc	Schalthebel Palanca de cambios	Shift lever Lever de change		
8	5000209490	1	pc	Hülse Collar	Collar Douille		
9	5000203763	2	pc	Anschlagpuffer Amortiguador	Shockmount Silentbloc		
10	5000212561	1	pc	Schenkelfeder Resorte	Spring Ressort		
11	5000212562	1	pc	Linsenschraube Tornillo gota de sebo	Countersunk screw Vis à tête bombée	5 x 20	
12	5000108370	9	pc	Linsenkopfschraube Tornillo gota de sebo	Oval head screw Vis noyée lentiforme		
13	5000222605	15	pc	Linsenkopfschraube Tornillo gota de seboatado	Oval head screw Vis noyée lentiforme	M 6 x 20	
14	5000213543	1	pc	Linsenkopfschraube Tornillo gota de seboatado	Oval head screw Vis noyée lentiforme	4x12	
15	5000015994	1	pc	Spiralspannstift Perno de sujeción	Spring dowel sleeve Goupille élastique	6 x 36	DIN7343
16	5000222383	1	pc	Bowdenzug Cable bowden	Bowden cable Câble de bowden		

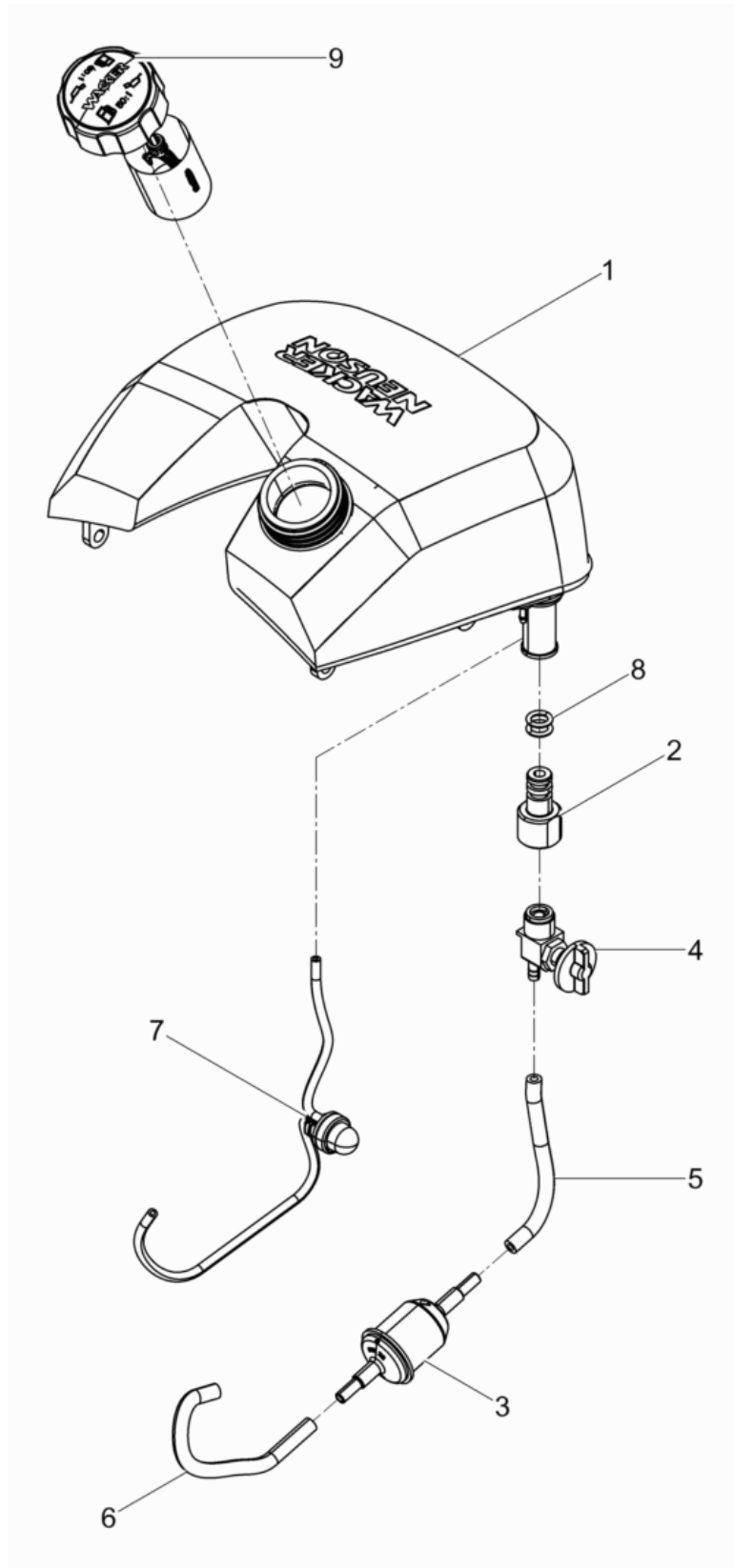

Pos. Item	Artikel Nr. Item no.	Pc.	Unit	Beschreibung Descripción	Description Description	Abm. Dim.	Norm Standard
						Drehmoment Torque	Schmierstoff Lubricant
1	5000213520	1	pc	Kraftstofftank Depósito de combustible	Fuel tank Réservoir à essence		
2	5000222378	1	pc	Anschlussstutzen Manguito	Muff Manchon		
3	5100022620	1	pc	Kraftstofffilter Filtro de combustible	Fuel filter Filtre à carburant		
4	5000222410	1	pc	Kraftstoffhahn Llave de combustible	Fuel cock Robinet d'essence		
5	5100014349	1	pc	Kraftstoffschlauch Manguera de combustible	Fuel hose Tuyau à essence		
6	5100014347	1	pc	Kraftstoffschlauch Manguera de combustible	Fuel hose Tuyau à essence		
7	5100036725	1	pc	Purger Mit Schlauch Bomba de combustible con manguera	Purger with hose Pompe à essence avec tuyau		
8	5000222610	2	pc	O-Ring Anillo-o	O-ring Joint torique	9x2,5	EN549
9	5000163681	1	pc	Tankdeckel Kpl. Tapa de tanque cpl.	Tank cover cpl. Couvercle du reservoir cpl.		

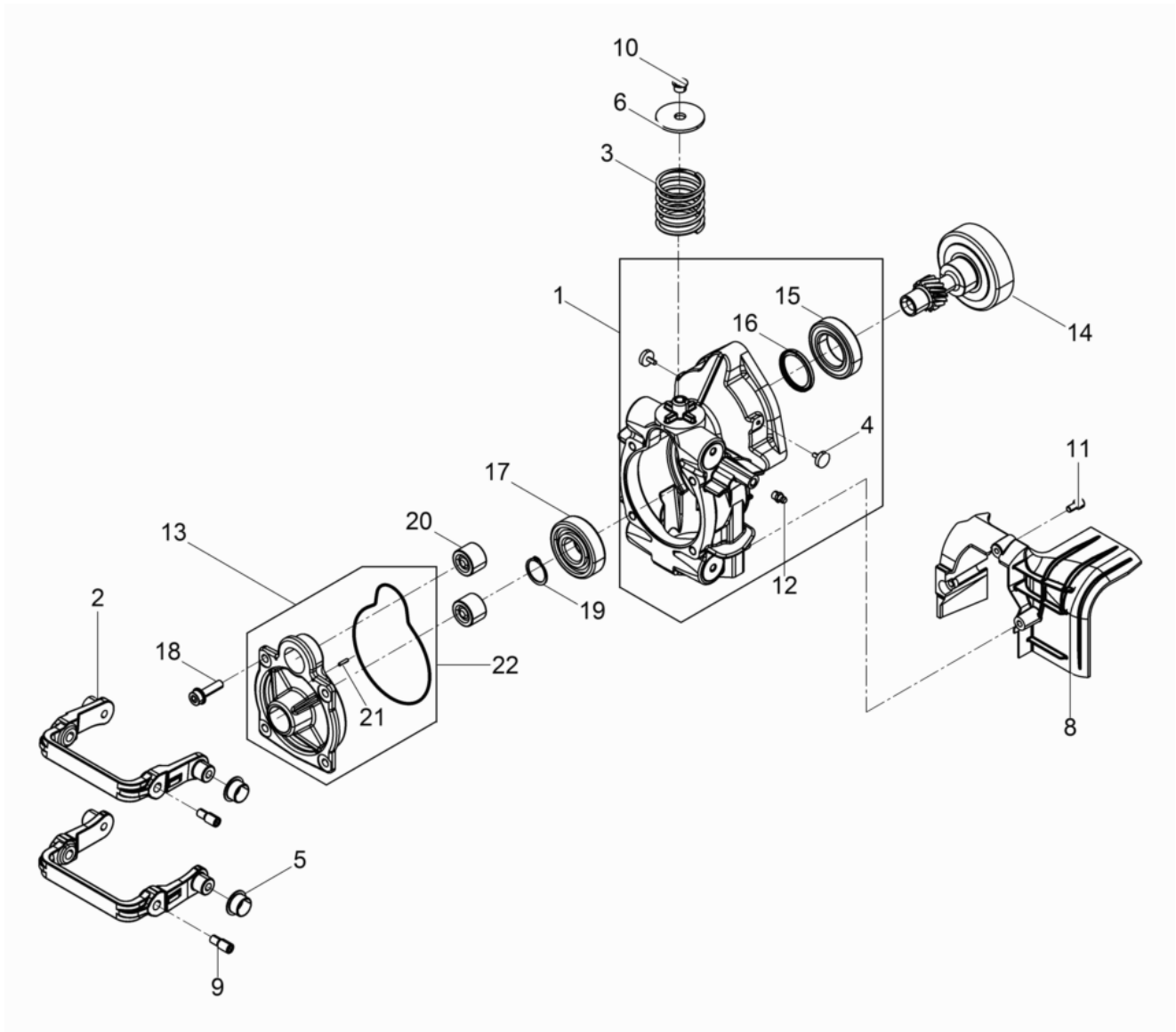

Pos. Item	Artikel Nr. Item no.	Pc.	Unit	Beschreibung Descripción	Description Description	Abm. Dim.	Norm Standard
						Drehmoment Torque	Schmierstoff Lubricant
1	5100001472	1	pc	Kurbelgehäuse Cárter	Crankcase Carter		
2	5000222472	2	pc	Schwinge Brazo de elevación	Lifting arm Bras de levage		
3	5000203765	1	pc	Druckfeder Resorte de compresión	Compression spring Ressort de pression		
4	5000207279	2	pc	Puffer Amortiguador	Shockmount Silentbloc	60x4	
5	5100032401	4	pc	Gleitlager Cojinete deslizante	Slide bearing Roulement de glissement		
6	5100002282	1	pc	Scheibe Arandela	Washer Rondelle	Ø11	
8	5000213526	1	pc	Luftführung Conducción de aire	Air ducting Carter ventilation		
9	5000211346	4	pc	Schraubenbolzen Tornillo	Screw Vis	M8	
10	5000222425	1	pc	Stopfen Enchufe	Plug Prise		
11	5100055395	3	pc	Zylinderschraube Tornillo cilíndrico	Cheese head screw Vis à tête cylindrique	10Nm/7ft.lbs	
12	5000222551	1	pc	Kegelschmiernippel Engrasador cónico	Tapered nipple Graisseur		DIN71412
13	5100001469	1	pc	Lagerflansch Kpl. Brida-rodamiento	Bearing flange Collerette-roulement		
14	5000202570	1	pc	Fliehkraftglocke Campana centrifuga	Clutch drum Carter embrayage		
15	5100000102	1	pc	Rillenkugellager Rodamiento a bolas	Grooved ball bearing Roulement rainuré à billes	6007	
16	5100001451	1	pc	Radial-Wellendichtring Anillo de sellado	Sealing ring Anneau d'étanchéité	35x45x4	
17	5000104712	1	pc	Rillenkugellager Rodamiento a bolas	Grooved ball bearing Roulement rainuré à billes		
18	5000222467	4	pc	Rippschraube Tornillo	Screw Vis	M 8x 30	
19	5002001041	1	pc	Sicherungsring Anillo de retención	Retaining ring Bague d'arrêt	25 x 1,2	DIN471
20	5000095740	2	pc	Nadelbüchse Cojinete de agujas	Needle bushing Douille d'aiguilles		
21	5000209452	2	pc	Spannstift Pasador	Roll pin Goupille de tension	3,0x 12	
22	5100001449	1	pc	O-Ring Anillo-o	O-ring Bague-o	115x2	

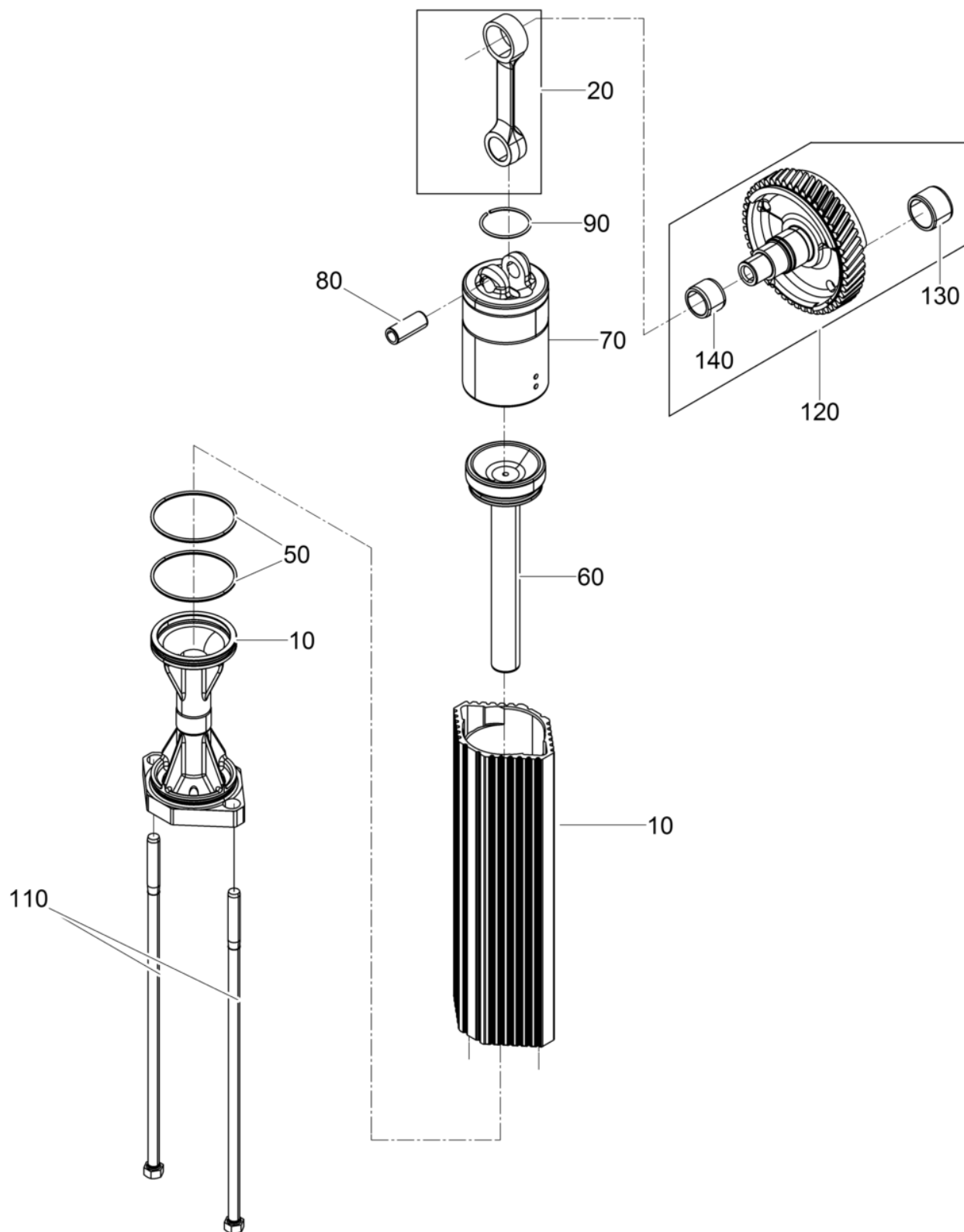

Pos. Item	Artikel Nr. Item no.	Pc.	Unit	Beschreibung Descripción	Description Description	Abm. Dim.	Norm Standard
						Drehmoment Torque	Schmierstoff Lubricant
10	5100056702	1	pc	Führungsbuchse Casquillo de guía	Guide bush Boîte		
20	5000200714	1	pc	Pleuel Kpl. Biela cpl.	Connecting rod cpl. Bielle cpl.		
50	5000209400	2	pc	O-Ring Anillo-o	O-ring Bague-o	70x3	
60	5000202298	1	pc	Schlagkolben Embolo percutor	Percussion piston Piston frappeur		
70	5000202214	1	pc	Antriebskolben Conduzca el pistón	Drive piston Conduisez le piston		
80	5000128470	1	pc	Bolzen Perno	Bolt Boulon		
90	5000202800	1	pc	Sprengring Anillo de retención	Snap ring Circlip	A45	DIN7993
100	5000202219	1	pc	Führungszylinder Cilindro de guía	Guide cylinder Cylindre de guidage		
110	5000201958	2	pc	Dehnschraube Tornillo de dilatación	Necked down screw Vis de dilatation	75Nm/55ft.lbs	
120	5000200715	1	pc	Kurbeltrieb Kpl. Mecanismo de manivela cpl.	Crank gear cpl. Arbre manivelle cpl.		
130	5002006602	1	pc	Innenring Anillo interior	Inner raceway Bague intérieur		
140	5000202993	1	pc	Innenring Anillo interior	Inner raceway Bague intérieur	IR 17x22x16	

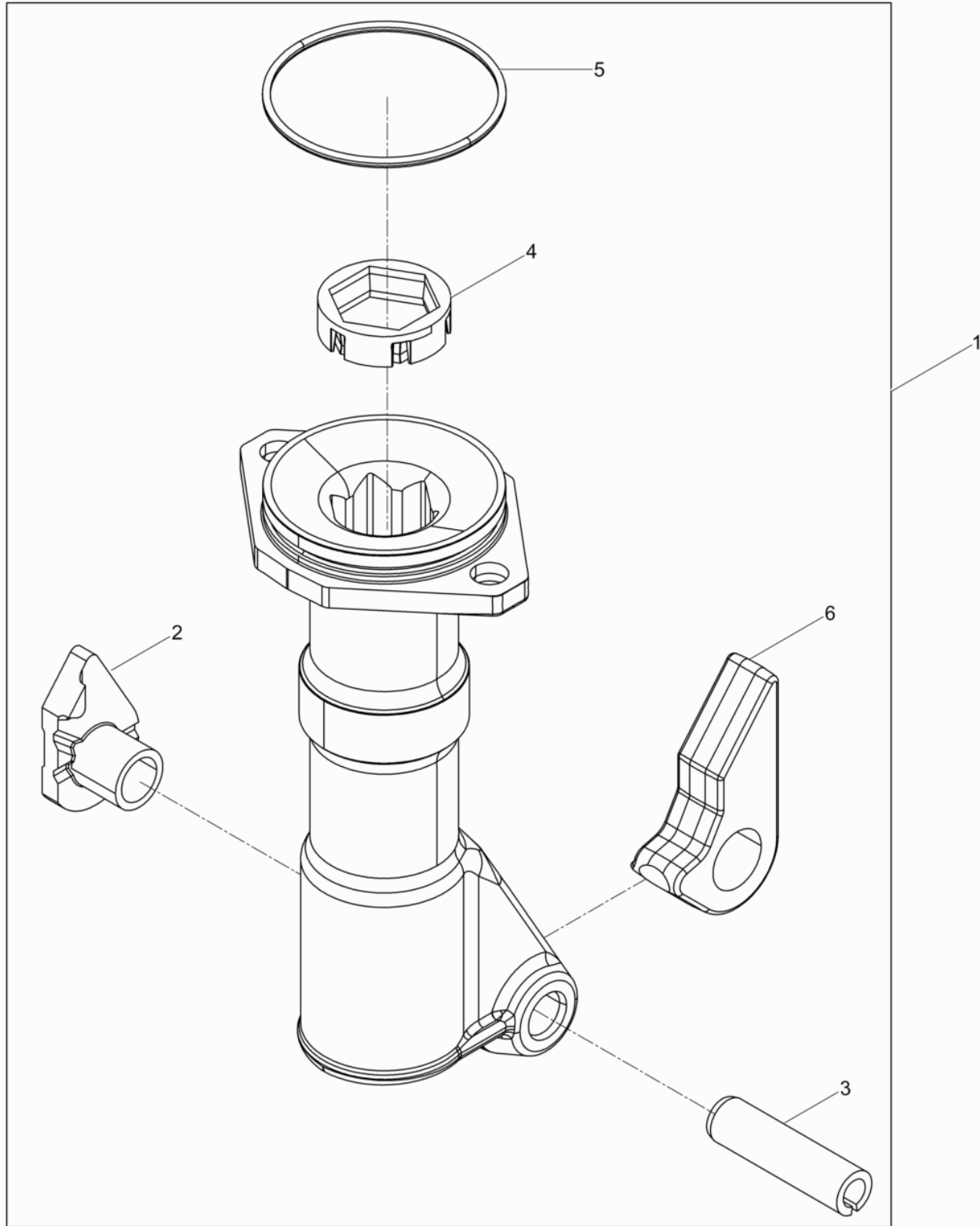

Pos. Item	Artikel Nr. Item no.	Pc.	Unit	Beschreibung Descripción	Description Description	Abm. Dim.	Norm Standard
						Drehmoment Torque	Schmierstoff Lubricant
1	5000215337	1	pc	Werkzeughalter Kpl. Porta-herramientas cpl.	Tool holder cpl. Porte-outils cpl.		
2	5000065323	1	pc	Klinkenbuchse Casquillo de trinquete	Ratchet bush Bôte de jack		
3	5000065289	1	pc	Spannstift Pasador de sujeción	Spring pin Goupille élastique	16 x 60	ISO8752
4	5000215334	1	pc	Dichtmanschette Anillo sellante	Sealing ring Bague d'étanchéité	32	
5	5002001341	1	pc	O-Ring Anillo-o	O-ring Bague-o	70 x 3	
6	5000215338	1	pc	Klinke Trinquete	Ratchet (pawl) Cliquet		

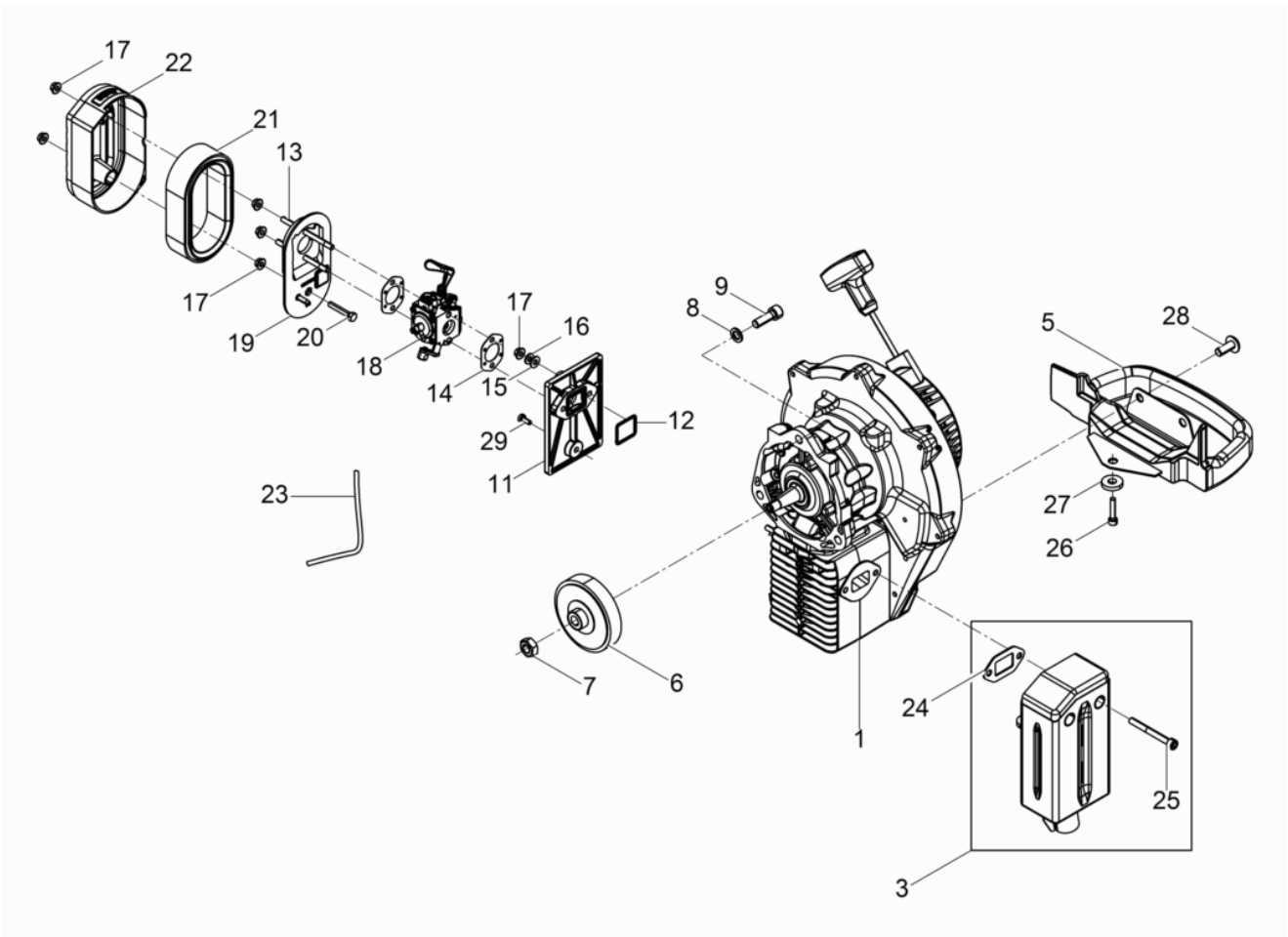

Pos. Item	Artikel Nr. Item no.	Pc.	Unit	Beschreibung Descripción	Description Description	Abm. Dim.	Norm Standard
						Drehmoment Torque	Schmierstoff Lubricant
1	5000180551	1	pc	Benzinmotor Motor a gasolina	Gas engine Moteur à essence		
3	5000222051	1	pc	Auspufftopf Kpl. Silenciador cpl.	Exhaust cpl. Pot d'échappement cpl.		
5	5000095213	1	pc	Zusatzhandgriff Empuñadura adicional	Supplementary handle Poignée supplémentaire		
6	5000043595	1	pc	Fliehkraftkupplung Embrague	Centrifugal clutch Embrayage		
7	5000010883	1	pc	Sechskantmutter Tuerca hexagonal	Hexagon nut Écrou hexagonal		
8	5000012397	3	pc	Federring Arandela elástica	Lock washer Rondelle de ressort	A8	DIN127
9	5000011542	3	pc	Zylinderschraube Tornillo cilíndrico	Cheese head screw Vis à tête cylindrique	25Nm/18ft.lbs	
11	5100001978	1	pc	Zwischenflansch Brida intermedia	Intermediate flange Bride intermediaire		
12	5100002961	1	pc	O-Ring Anillo-o	O-ring Bague-o	26x2	
13	5000211953	2	pc	Stiftschraube Perno prisionero	Stud Boulon		
14	5000095774	2	pc	Dichtung Junta	Seal Joint		
15	5000103212	2	pc	Scheibe Arandela	Washer Rondelle	5	DIN134
16	5000103211	2	pc	Spannscheibe Arandela elástica	Lockwasher Rondelle de ressort	5	DIN6796
17	5000047488	7	pc	Sechskantmutter Tuerca hexagonal	Hexagon nut Écrou hexagonal	M5 7Nm/5ft.lbs	DIN6923
18	5000222675	1	pc	Membranvergaser Carburador	Carburetor Carburateur		
19	5000207688	1	pc	Luftfiltergehäuse Carcasa filtro de aire	Air filter housing Carter de filtre		
20	5000011473	1	pc	Sechskantschraube Tornillo hexagonal	Hexagonal head cap screw Vis à tête hexagonale	M5 x 30 6Nm/4ft.lbs	DIN933
21	5000095711	1	pc	Luftfilter Filtro del aire	Air cleaner Filtre à air		
22	5000222499	1	pc	Luftfiltergehäusedeckel Tapa filtro de aire	Air filter cover Couvercle filtre à air		
23	5000211957	1	pc	Kompensationsschlauch Manguera de la remuneración	Compensation hose Tuyau de compensation		
24	5000012202	1	pc	Auspuffdichtung Junta	Gasket Joint		
25	5000222176	2	pc	Zylinderschraube Tornillo cilíndrico	Cheese head screw Vis à tête cylindrique	M 6x 55	ISO4762
26	5000129420	1	pc	Zylindersicherungsschraube Tornillo de seguridad	Socket head cap screw Poignée supplémentaire	35Nm/26ft.lbs	
27	5000045719	1	pc	Scheibe Arandela	Flat washer Rondelle	8,4	DIN7349
28	5100001450	2	pc	Schraube Tornillo	Screw Vis	M8x20 25Nm/18ft.lbs	
29	5000222072	1	pc	Schraube Tornillo	Screw Vis	M 4x 10	

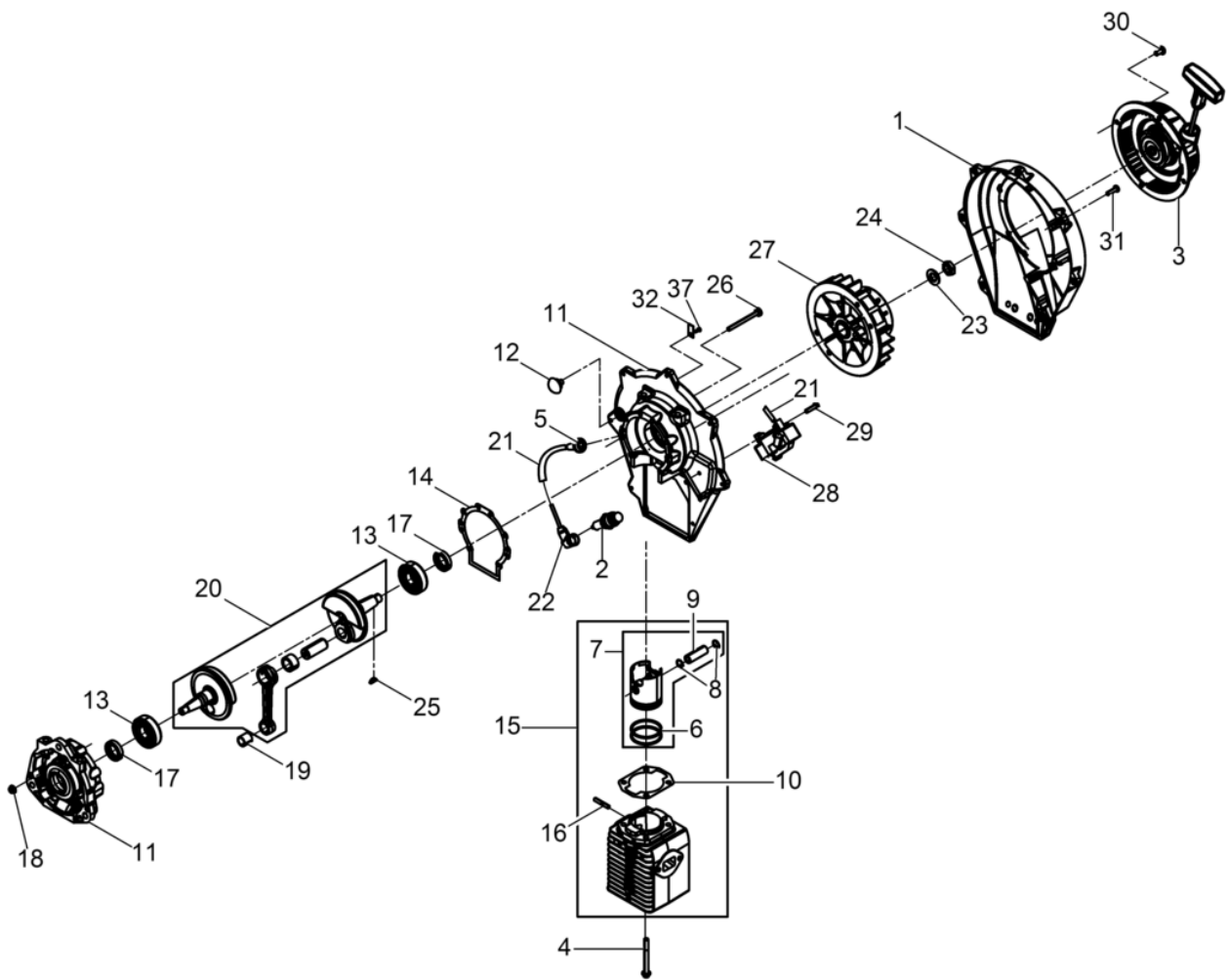

Pos. Item	Artikel Nr. Item no.	Pc.	Unit	Beschreibung Descripción	Description Description	Abm. Dim.	Norm Standard
						Drehmoment Torque	Schmierstoff Lubricant
	5000048212	1	pc	Dichtungssatz Juego de juntas	Gasket set Jeu de joints		
1	5000215115	1	pc	Gebläsedeckel Tapa de ventilador	Fan hood Couvercle du sys. de vent.		
2	5000033368	1	pc	Zündkerze Bujía	Spark plug Bougie		
3	5000046098	1	pc	Starter Arrancador	Rewind starter Démarrreur		
4	5000095917	4	pc	Zylinderschraube Tornillo cilíndrico	Cheese head screw Vis à tête cylindrique	M6 x 60	
5	5100060760	1	pc	Kabeldurchführung Conducto de cable	Cable passage Passage de câble		
6	5000045904	2	pc	Kolbenring Aro de pistón	Piston ring Segment de piston	45 x 1,5	DIN70910
7	5000045908	1	pc	Kolben Kpl. Pistón cpl.	Piston cpl. Piston cpl.		
8	5000012257	2	pc	Drahtsprengring Anillo de retención	Retaining ring Bague d'arrêt	A12	DIN73123
9	5000012199	1	pc	Kolbenbolzen Pasador de pistón	Piston pin Axe de piston		
10	5100025323	1	pc	Zylinderdichtung Junta del cilindro	Cylinder gasket Joint de cylindre		
11	5000180550	1	pc	Kurbelgehäuse Cárter	Crankcase Carter		
12	5002007007	1	pc	Kurzschlußknopf Interruptor de botón	Push button switch Interrupteur à poussoir		
13	5100065070	2	pc	Rillenkugellager Rodamiento de bolas	Grooved ball bearing Roulement à billes		
14	5100025322	1	pc	Kurbelgehäusedichtung Junta	Gasket Joint		
15	5000176400	1	pc	Zylinder Mit Kolben Cilindro con pistón	Cylinder with piston Cylindre avec piston		
16	5100027617	2	pc	Stiftschraube Perno prisionero	Stud Boulon	M5x20	
17	5000154699	2	pc	Wellendichtring Anillo de retén radial	Shaft seal Bague d'étanchéité	20 x 30 x 7	
18	5000047488	8	pc	Sechskantmutter Tuerca hexagonal	Hexagon nut Écrou hexagonal	M5 7Nm/5ft.lbs	DIN6923
19	5000034835	1	pc	Nadelkranz Rodamiento de agujas	Needle bearing Roulement à aiguilles		
20	5000045036	1	pc	Kurbelwelle Cigueñal	Crankshaft Vilebrequin		
21	5000047348	1	pc	Schutzschlauch Manguito	Sleeve Douille		
22	5000076521	1	pc	Zündkabel Cable del encendido	Ignition cable Câble d'allumage		
23	5000010620	1	pc	Scheibe Arandela	Flat washer Rondelle	12	ISO7090
24	5000045914	1	pc	Sechskantmutter Tuerca hexagonal	Hexagon nut Écrou hexagonal	M12 x 1,5	ISO8675
25	5000010388	1	pc	Scheibenfeder Chaveta woodruff	Woodruff key Clavette woodruff	3 x 5	DIN6888
26	5000215365	8	pc	Zylinderschraube Tornillo cilíndrico	Cheese head screw Vis à tête cylindrique	M 5x 60	
27	5000045041	1	pc	Lüfterrad Ventilador	Fan Ventilateur		

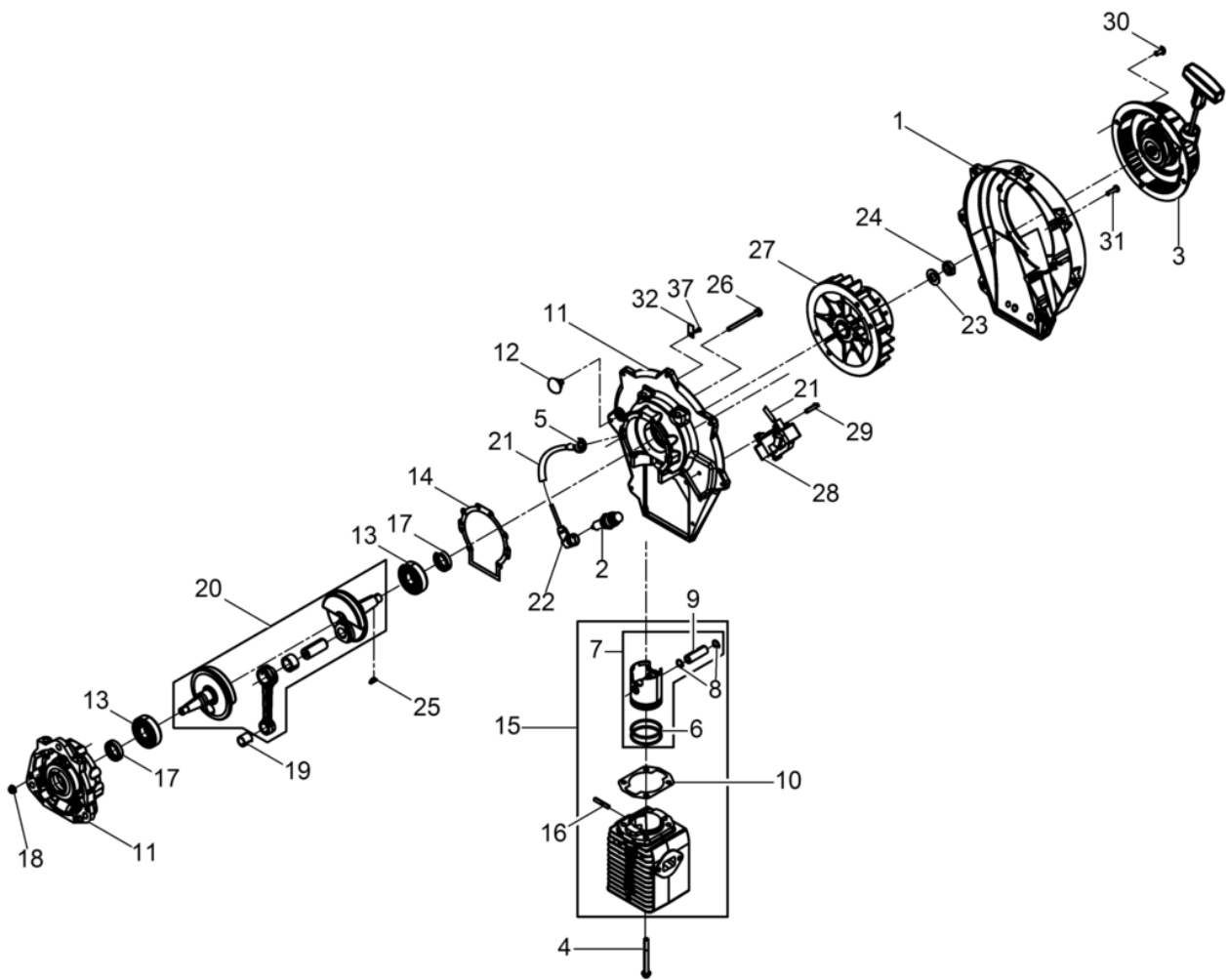

Pos. Item	Artikel Nr. Item no.	Pc.	Unit	Beschreibung Descripción	Description Description	Abm. Dim.	Norm Standard
						Drehmoment Torque	Schmierstoff Lubricant
28	5000103302	1	pc	Zündanlage M. Verstellung Instalación de encendido de tubo regulador	Magneto armature with adjustable tube Installation dallumage avec		
29	5100049413	3	pc	Schraube Tornillo	Screw Vis		
30	5000011787	4	pc	Flachkopfschraube Tornillo de cabeza plana atado	Pan head screw Vis lentiforme	M6 x 12	ISO1580
31	5100049413	7	pc	Schraube Tornillo	Screw Vis		
32	5000045906	2	pc	Halter Retenedor	Retainer Arrêtoir		
37	5100027591	1	pc	Blindniet Remache ciego	Blind rivet Rivet dobturation	3x8	

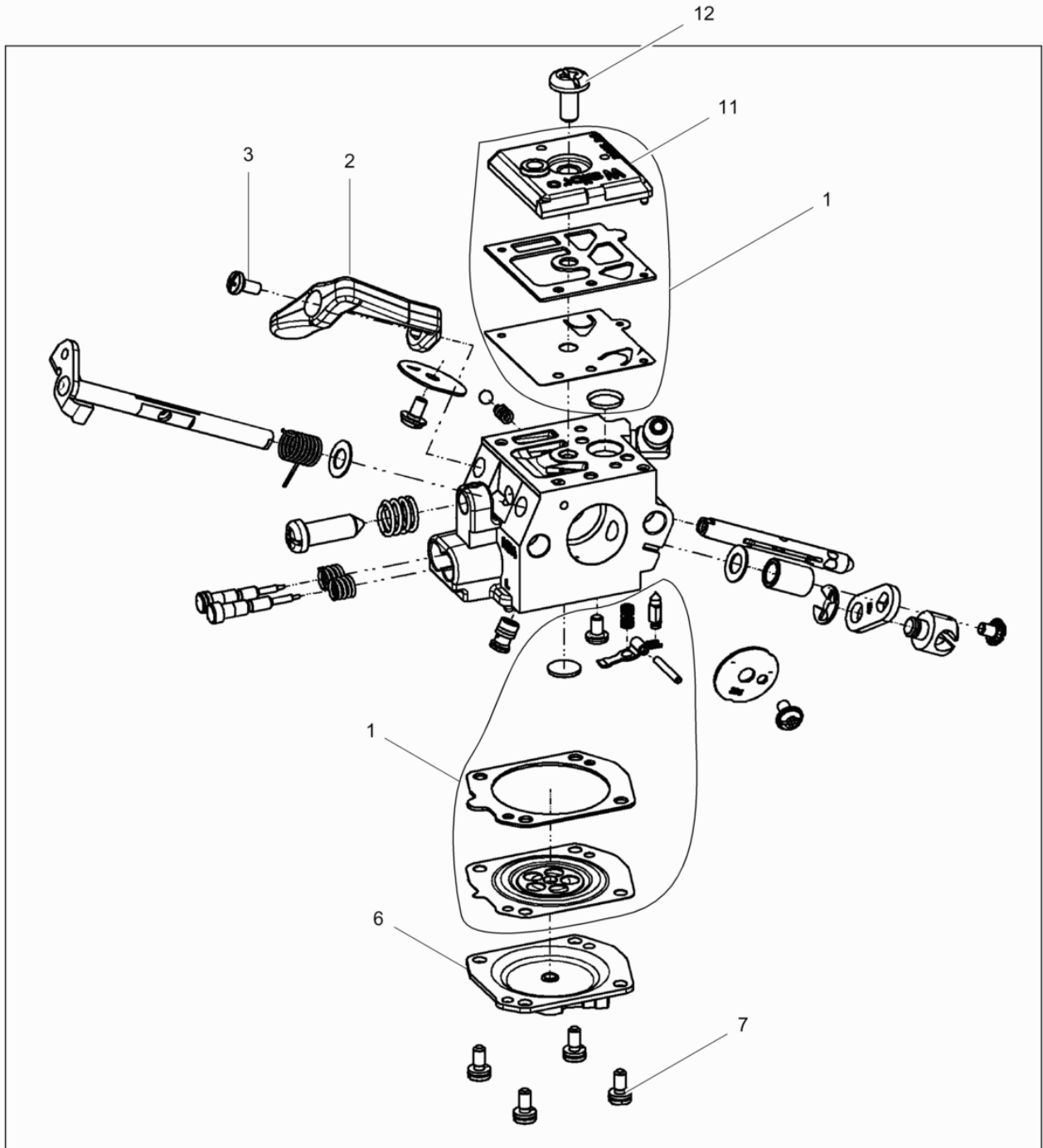

Pos. Item	Artikel Nr. Item no.	Pc.	Unit	Beschreibung Descripción	Description Description	Abm. Dim.	Norm Standard
						Drehmoment Torque	Schmierstoff Lubricant
1	5000222003	1	pc	Vergaser Reparatursatz Carburador juego de reparaciónador	Carburetor repair kit Carbureteur jeu de réparation		
2	5000222004	1	pc	Chokehebel Palanca estranguladora	Choke control lever Levier d'étrangleur		
3	5000222005	1	pc	Schraube Tornillo	Screw Vis		
6	5000222008	1	pc	Deckel Cubierta	Cover Couvercle		
7	5000222009	4	pc	Schraube Tornillo	Screw Vis		
11	5000222013	1	pc	Deckel Cubierta	Cover Couvercle		
12	5000222014	1	pc	Schraube Tornillo	Screw Vis		

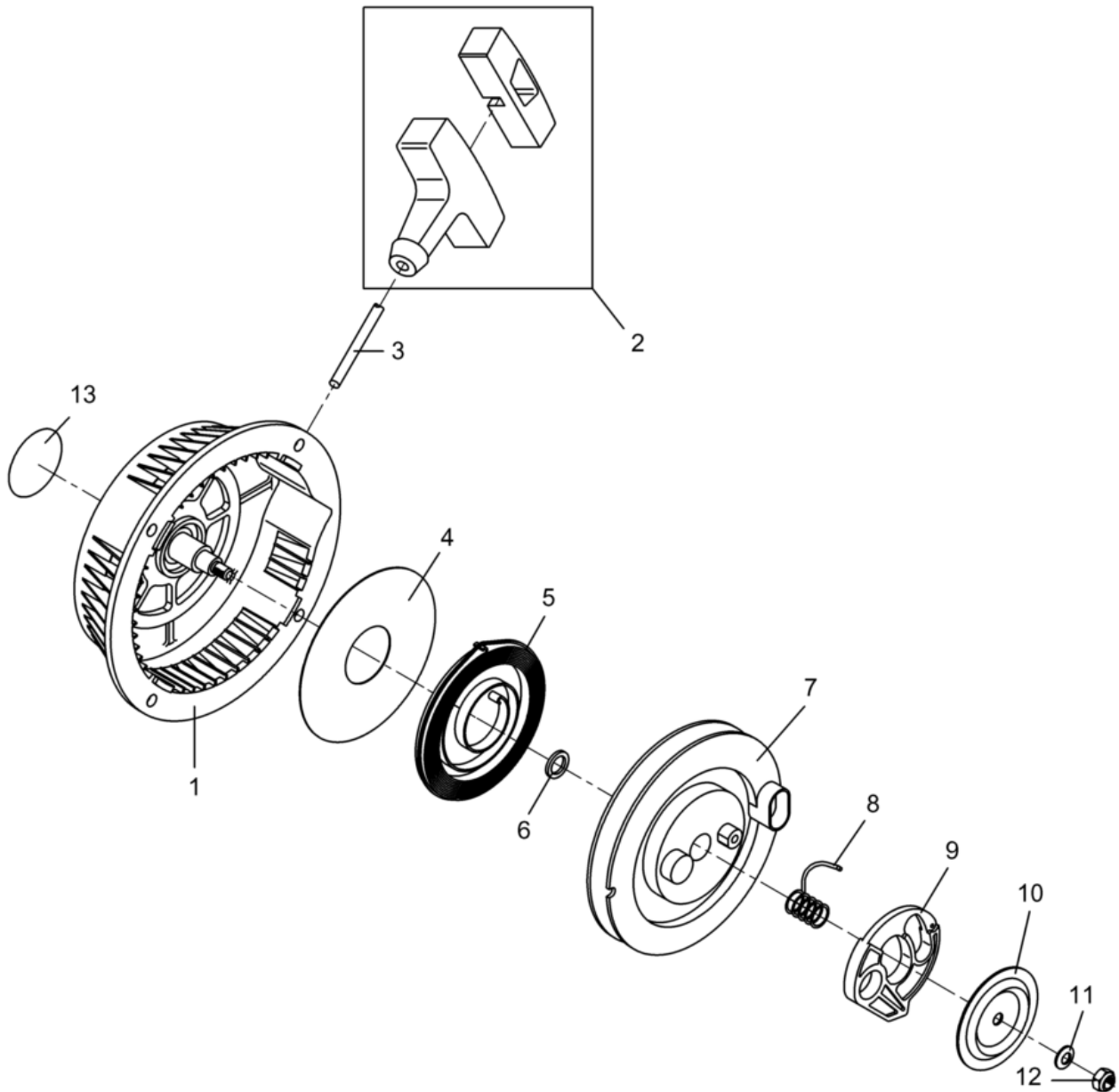

Pos. Item	Artikel Nr. Item no.	Pc.	Unit	Beschreibung Descripción	Description Description	Abm. Dim.	Norm Standard
						Drehmoment Torque	Schmierstoff Lubricant
1	5000048063	1	pc	Startergehäuse Caja del arrancador	Starter housing Carter de démarreur		
2	5000044233	1	pc	Startergriff Kpl. Empuñadura del arranque	Starter handle Poignée du lanceur		
3	5000104548	1	pc	Starterseil Cuerda de arranque	Starter rope Corde de starter		
4	5000065068	1	pc	Anlaufscheibe Arandela tope	Check disc Disque		
5	5000048061	1	pc	Rückholfeder Resorte	Spring Ressort		
6	5000048062	1	pc	Scheibe Arandela	Washer Rondelle		
7	5000048060	1	pc	Seilscheibe Polea	Starter pulley Poulie de démarrage		
8	5000048059	1	pc	Drehfeder Resorte	Spring Ressort		
9	5000047998	1	pc	Klinke Trinquete	Ratchet (pawl) Cliquet		
10	5000047997	1	pc	Führungsscheibe Tapa	Cover Couvercle		
11	5000058381	1	pc	Spannscheibe Arandela elástica	Lockwasher Rondelle de ressort	6	DIN6796
12	5000058553	1	pc	Sechskantmutter Tuerca hexagonal	Hexagon nut Écrou hexagonal	M6	DIN980
13	5000114608	1	pc	Aufkleber Calcomanía	Label Autocollant		

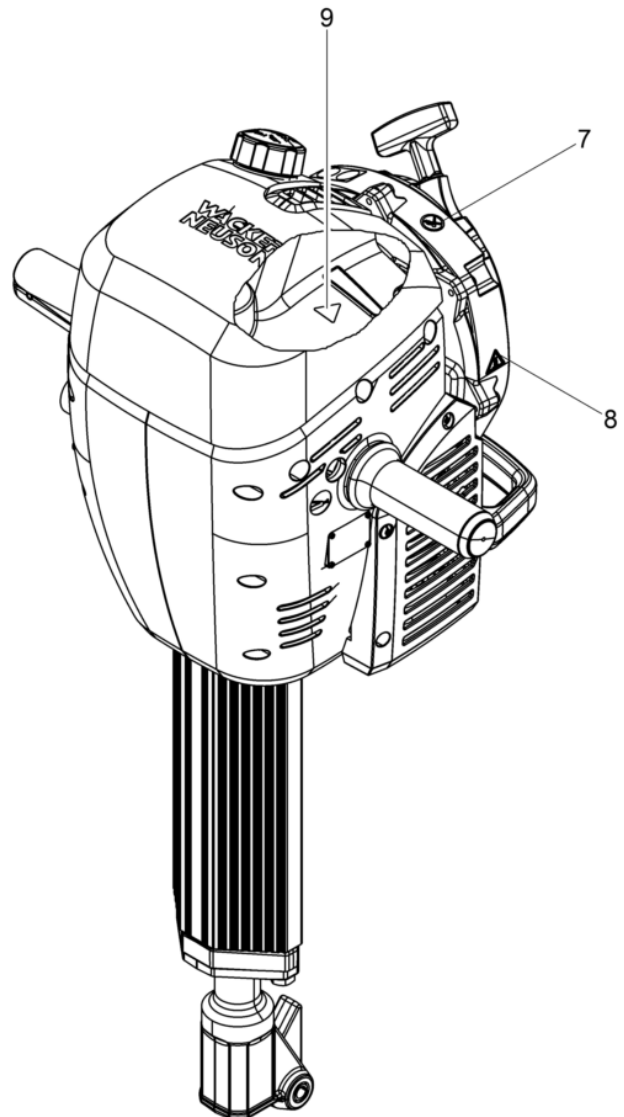
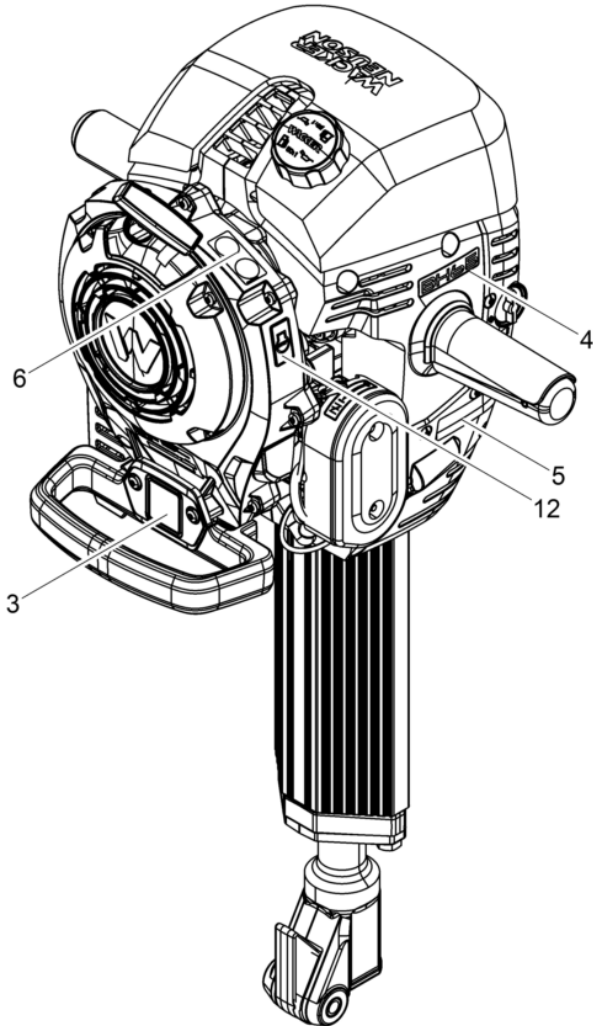

Pos. Item	Artikel Nr. Item no.	Pc.	Unit	Beschreibung Descripción	Description Description	Abm. Dim.	Norm Standard
						Drehmoment Torque	Schmierstoff Lubricant
3	5000064925	1	pc	Aufkleber-Schalleistungspegel Etiqueta autoadhesiva-nivel de potencia acúëstica	Decal-sound power level Autocollante-niveau sonore		
4	5000222623	1	pc	Aufkleber Typenbezeichnung Tipo etiqueta autoadhesiva	Type label Autocollant de type		
5	5000222089	1	pc	Aufkleber Logo Calcomania insignia	Label logo Autocollant logo		
6	5000219174	1	pc	Aufkleber Calcomanias	Labels Autocollants		
7	5000219180	1	pc	Aufkleber Calcomanias	Labels Autocollants		
8	5000219114	1	pc	Aufkleber Calcomanias	Labels Autocollants		
9	5000219177	1	pc	Aufkleber Calcomanias	Labels Autocollants		
12	5000114746	1	pc	Aufkleber Calcomania	Label Autocollant		

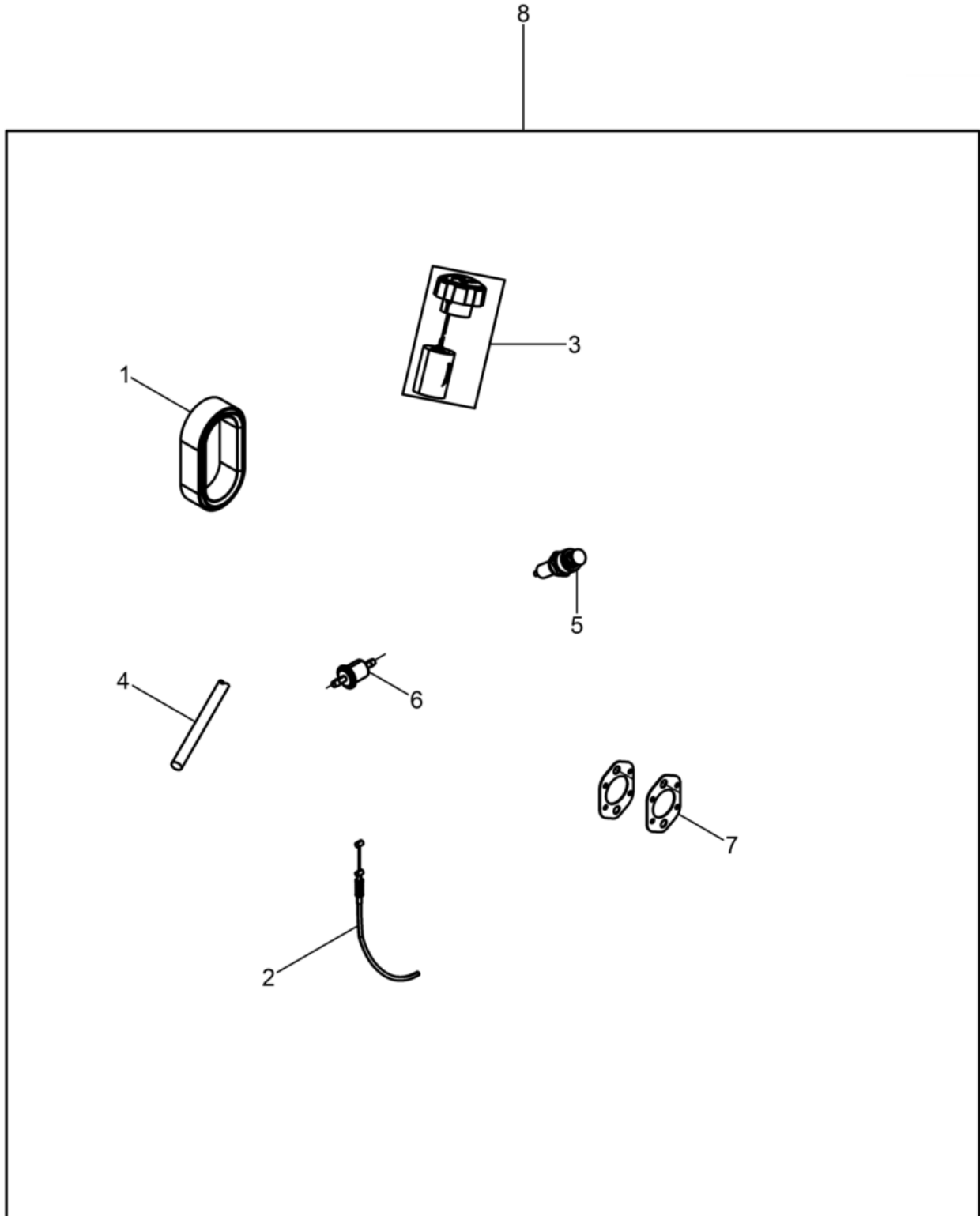

Pos. Item	Artikel Nr. Item no.	Pc.	Unit	Beschreibung Descripción	Description Description	Abm. Dim.	Norm Standard
						Drehmoment Torque	Schmierstoff Lubricant
1	5000095711	1	pc	Luftfilter Filtro del aire	Air cleaner Filtre à air		
2	5000222383	1	pc	Bowdenzug Cable bowden	Bowden cable Câble de bowden		
3	5000163681	1	pc	Tankdeckel Kpl. Tapa de tanque cpl.	Tank cover cpl. Couvercle du reservoir cpl.		
4	5000104548	1	pc	Starterseil Cuerda de arranque	Starter rope Corde de starter		
5	5000033368	1	pc	Zündkerze Bujía	Spark plug Bougie		
6	5000215363	1	pc	Kraftstofffilter Filtro de combustible	Fuel filter Filtre à carburant		
7	5000095774	1	pc	Dichtung Junta	Seal Joint		
8	5100004109	1	pc	Wartungspaket Juego para mantenimientobh 55, 65	Maintenance kit Jeu d'entretien bh 55, 65		

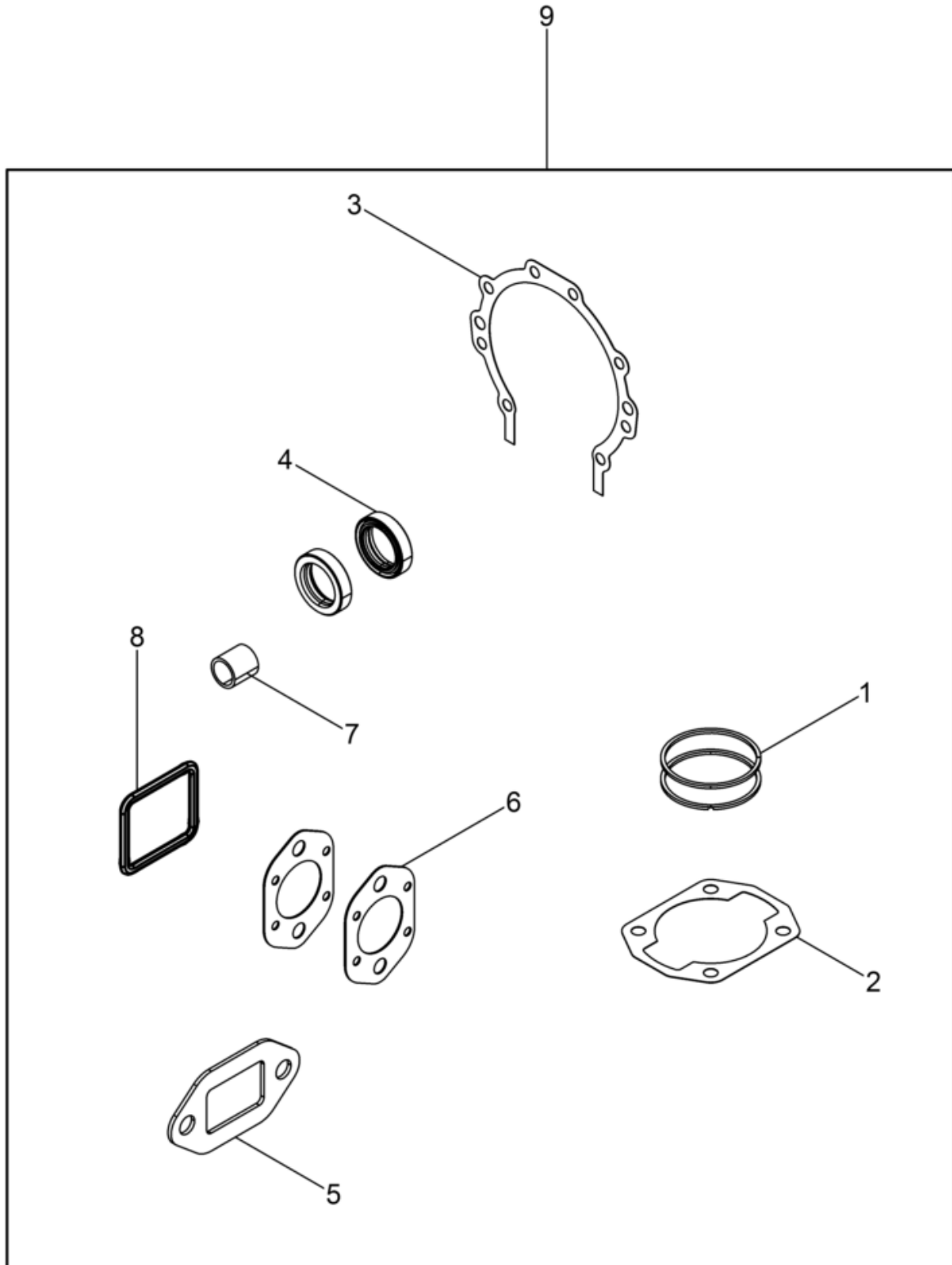

Pos. Item	Artikel Nr. Item no.	Pc.	Unit	Beschreibung Descripción	Description Description	Abm. Dim.	Norm Standard
						Drehmoment Torque	Schmierstoff Lubricant
1	5000045904	2	pc	Kolbenring Aro de pistón	Piston ring Segment de piston	45 x 1,5	DIN70910
2	5000045910	1	pc	Zylinderkopfdichtung Junta de culata del cilindro	Cylinder head gasket Joint de culasse de cylindre		
3	5000045034	1	pc	Kurbelgehäusedichtung Junta	Gasket Joint		
4	5000154699	2	pc	Wellendichtring Anillo de retén radial	Shaft seal Bague d'étanchéité	20 x 30 x 7	
5	5000012202	1	pc	Auspuffdichtung Junta	Gasket Joint		
6	5000095774	2	pc	Dichtung Junta	Seal Joint		
7	5000034835	1	pc	Nadelkranz Rodamiento de agujas	Needle bearing Roulement à aiguilles		
8	5100002961	1	pc	O-Ring Anillo-o	O-ring Bague-o	26x2	
9	5100004111	1	pc	Reparaturpaketwm 80 Kolbenring Juego de reparaciónwm 80 aro de pistón	Repair kit wm 80 piston ring Jeu de réparation wm 80		

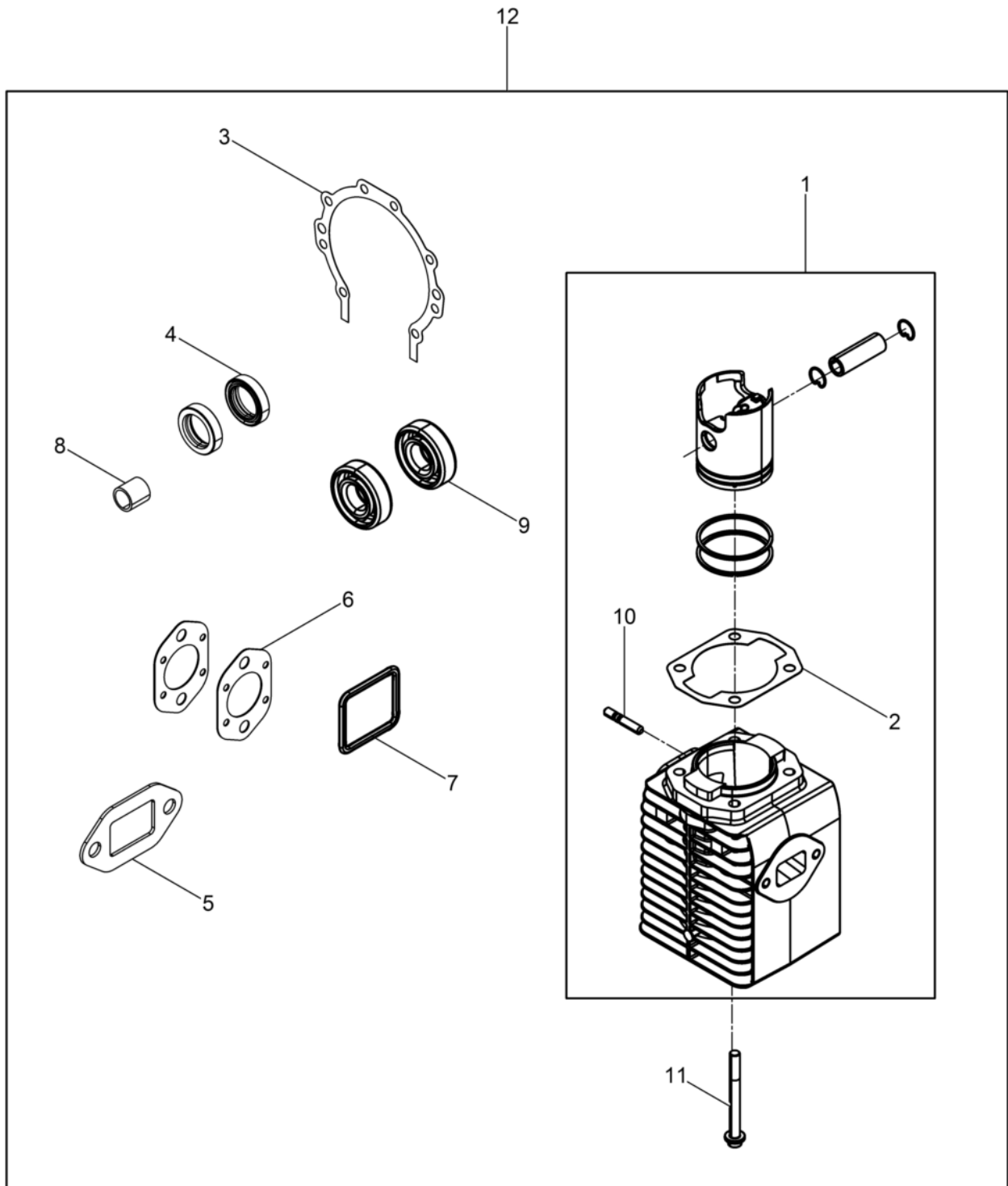

Pos. Item	Artikel Nr. Item no.	Pc.	Unit	Beschreibung Descripción	Description Description	Abm. Dim.	Norm Standard
						Drehmoment Torque	Schmierstoff Lubricant
1	5000176400	1	pc	Zylinder Mit Kolben Cilindro con pistón	Cylinder with piston Cylindre avec piston		
2	5000045910	1	pc	Zylinderkopfdichtung Junta de culata del cilindro	Cylinder head gasket Joint de culasse de cylindre		
3	5000045034	1	pc	Kurbelgehäusedichtung Junta	Gasket Joint		
4	5000154699	2	pc	Wellendichtring Anillo de retén radial	Shaft seal Bague d'étanchéité	20 x 30 x 7	
5	5000012202	1	pc	Auspuffdichtung Junta	Gasket Joint		
6	5000095774	2	pc	Dichtung Junta	Seal Joint		
7	5100002961	1	pc	O-Ring Anillo-o	O-ring Bague-o	26x2	
8	5000034835	1	pc	Nadelkranz Rodamiento de agujas	Needle bearing Roulement à aiguilles		
9	5100065070	2	pc	Rillenkugellager Rodamiento de bolas	Grooved ball bearing Roulement à billes		
10	5000013499	2	pc	Stiftschraube Tornillo espárrago	Stud bolt Goupille fileté	M5 x 20	DIN835
11	5000095917	4	pc	Zylinderschraube Tornillo cilíndrico	Cheese head screw Vis à tête cylindrique	M6 x 60	
12	5100004116	1	pc	Reparaturpaket WM 80Kat Zylinder Mit Kolben Juego de reparación wm 80 catcilindro con pistón	Repair kit wm 80 catcylinder with piston Jeu de réparation wm 80		

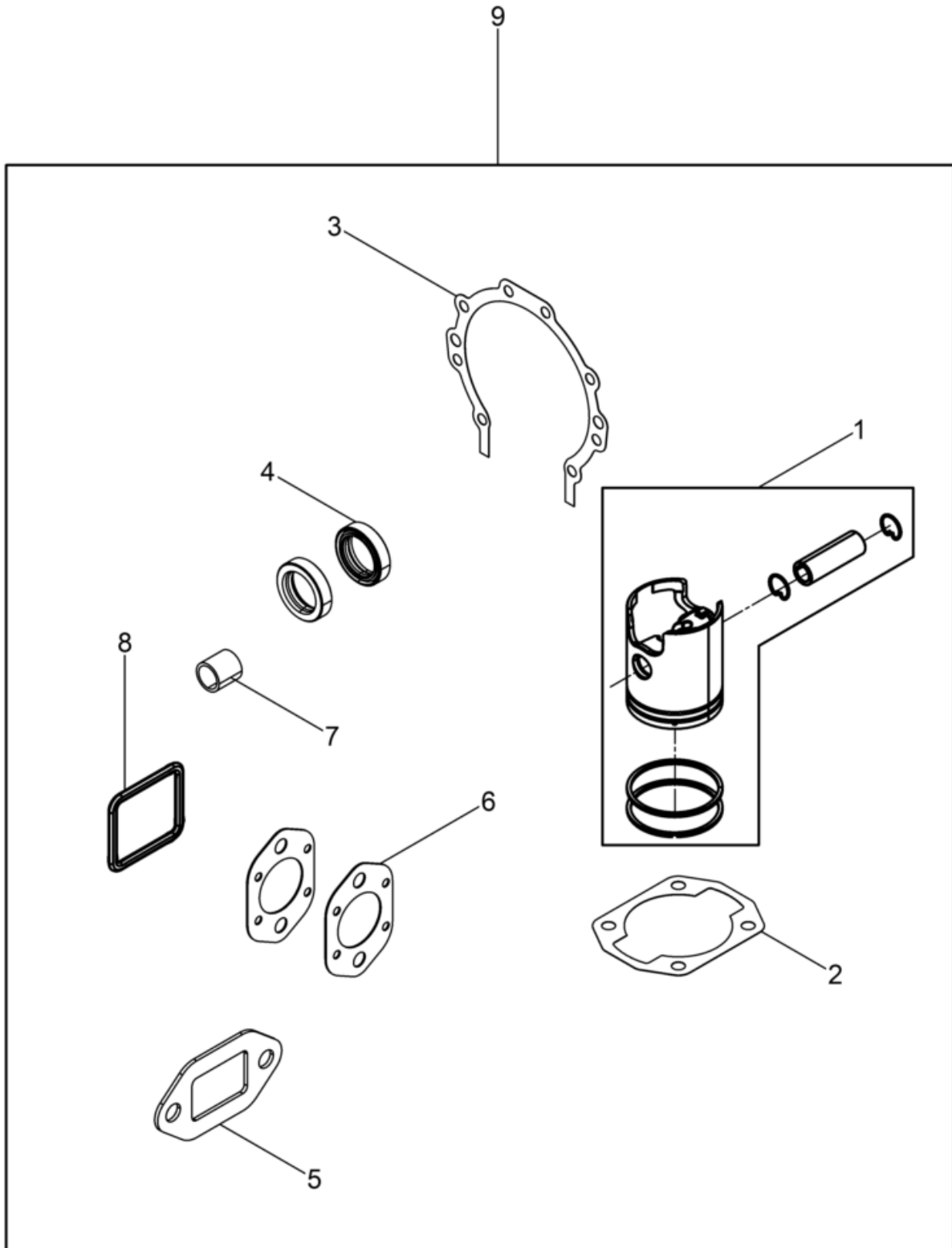

Pos. Item	Artikel Nr. Item no.	Pc.	Unit	Beschreibung Descripci3n	Description Description	Abm. Dim.	Norm Standard
						Drehmoment Torque	Schmierstoff Lubricant
1	5000045908	1	pc	Kolben Kpl. Pist3n cpl.	Piston cpl. Piston cpl.		
2	5000045910	1	pc	Zylinderkopfdichtung Junta de culata del cilindro	Cylinder head gasket Joint de culasse de cylindre		
3	5000045034	1	pc	Kurbelgehäusedichtung Junta	Gasket Joint		
4	5000154699	2	pc	Wellendichtring Anillo de ret3n radial	Shaft seal Bague d'3tanch3it3	20 x 30 x 7	
5	5000012202	1	pc	Auspuffdichtung Junta	Gasket Joint		
6	5000095774	2	pc	Dichtung Junta	Seal Joint		
7	5000034835	1	pc	Nadelkranz Rodamiento de agujas	Needle bearing Roulement 3 aiguilles		
8	5100002961	1	pc	O-Ring Anillo-o	O-ring Bague-o	26x2	
9	5100004114	1	pc	Reparaturpaket WM 80 Kolben Juego de reparaci3nwm 80 pist3n	Repair kit wm 80 piston Jeu de r3paration wm 80 piston		

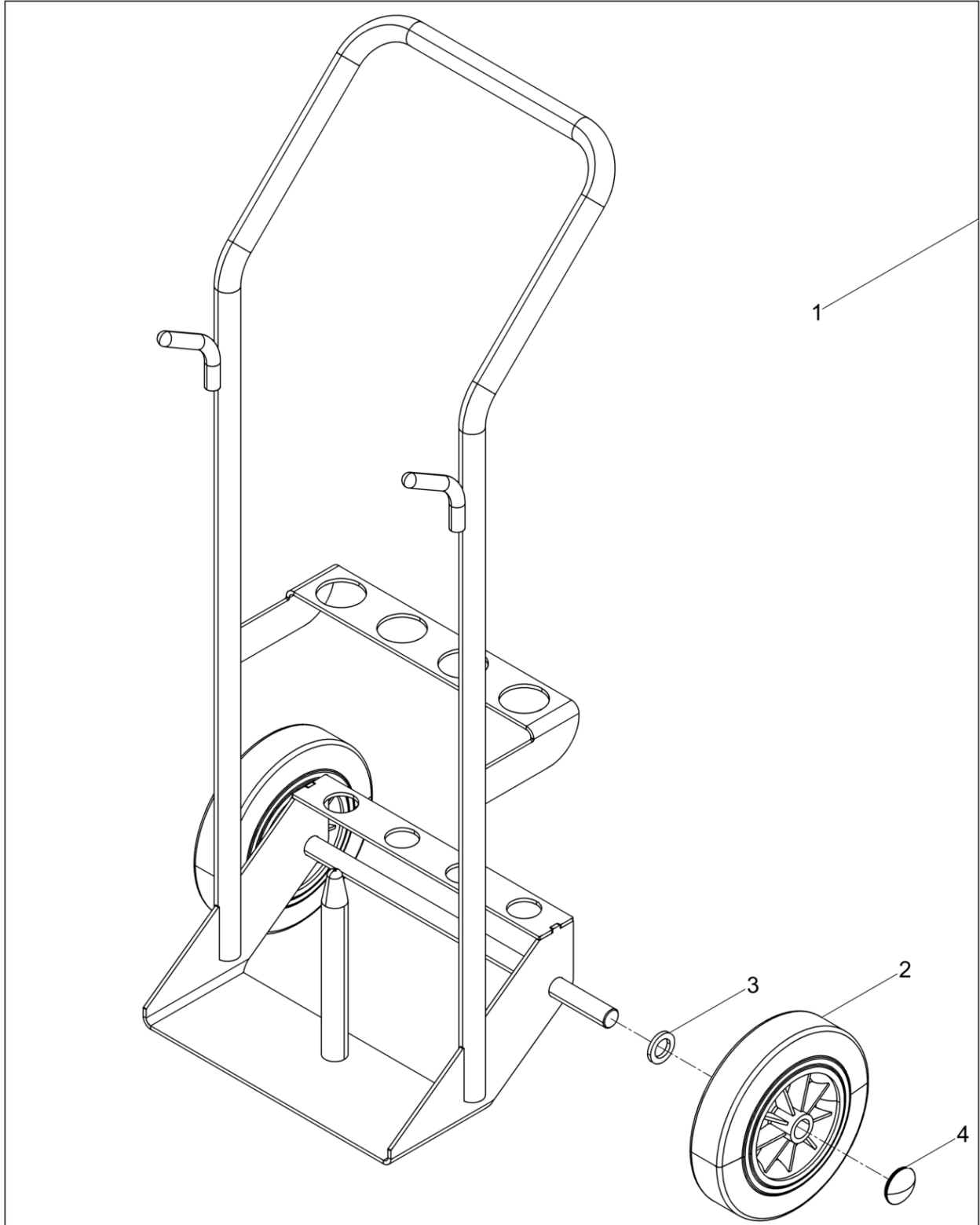

Pos. Item	Artikel Nr. Item no.	Pc.	Unit	Beschreibung Descripción	Description Description	Abm. Dim.	Norm Standard
						Drehmoment Torque	Schmierstoff Lubricant
1	5000208699	1	pc	Transportwagen Carro transportación	Cart transportation Voiturette transport		
2	5000201653	2	pc	Rad Rueda	Wheel Roue	200x50	
3	5000010662	2	pc	Scheibe Arandela	Flat washer Rondelle	20	DIN1440
4	5000039752	2	pc	Starlockkappen Tapa	Cap Chapeau	20 mm	

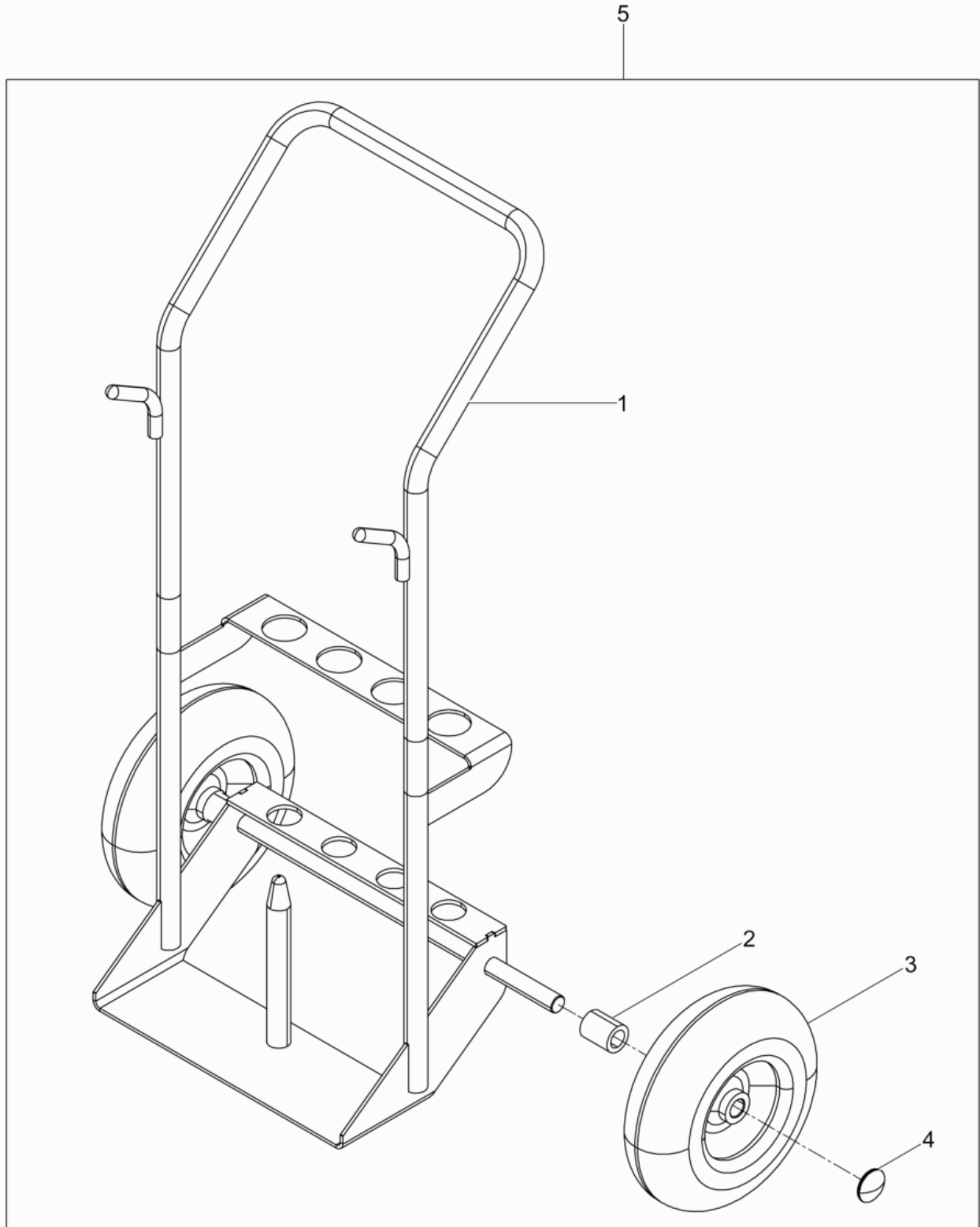

Pos. Item	Artikel Nr. Item no.	Pc.	Unit	Beschreibung Descripción	Description Description	Abm. Dim.	Norm Standard
						Drehmoment Torque	Schmierstoff Lubricant
1	5000215341	1	pc	Transportwagen Carro transportación	Cart transportation Voiturette transport		
2	5000215345	2	pc	Hülse Collar	Collar Douille		
3	5002003396	2	pc	Rad Rueda	Tire Roue		
4	5000039752	2	pc	Starlockkappen Tapa	Cap Chapeau	20 mm	
5	5000215340	1	pc	Transportwagen Carro transportación cpl.	Cart transportation cpl. Voiturette transport cpl.		



**WACKER
NEUSON**