



**WACKER
NEUSON**

5200019254	121
06.2018	

**Trench Rollers
Grabenwalzen
Rodillos para Zanjas
Rouleaux à pieds d'ameurs**

RTLx-SC3

**Parts Book
Ersatzteile
Lista de Repuestos
Liste de Pièces de Rechange**

www.wackerneuson.com

A nameplate listing the Model Number, Item Number, Revision, and Serial Number is attached to each unit. Please record the information found on this plate so it will be available should the nameplate become lost or damaged. When ordering parts or requesting service information, you will always be asked to specify the model, item number, revision number, and serial number of the unit.

Ein Typenschild mit Typ, Artikelnummer, Version und Maschinen-Nummer ist an jedem Gerät angebracht. Die Daten von diesem Schild bitte notieren, damit sie auch bei Verlust oder Beschädigung des Schildes noch vorhanden sind. Der Typ, die Artikel-Nummer, die Versions- Nummer und die Maschinen-Nummer sind bei der Ersatzteilbestellung oder Nachfragen bezüglich Service-Informationen stets erforderlich.

Una placa de identificación con el modelo, número de referencia, nivel de revisión y número de serie ha sido añadida en cada máquina. Favor de anotar los datos en la placa en caso de que la placa de identificación sea destruida o perdida. En todos los pedidos para repuestos necesita siempre el modelo, el número de referencia, el nivel de revisión y el número de serie de la máquina en cuestión.

Une plaque signalétique mentionnant le modèle, le numéro de référence, le niveau de révision et le numéro de série est fixée sur chaque machine. Veuillez noter les informations relevées sur cette plaque de façon à ce qu'elles soient toujours disponibles si la plaque signalétique venait à être perdue ou endommagée. Lorsque vous commandez des pièces détachées ou vous sollicitez des informations après-vente, on vous demandera toujours de préciser le modèle, le numéro de référence, le niveau de révision et le numéro de série de la machine.

***My machine's numbers are / Die Nummern meines Gerätes sind /
Los números de mi máquina son / Les numéros de ma machine son :***

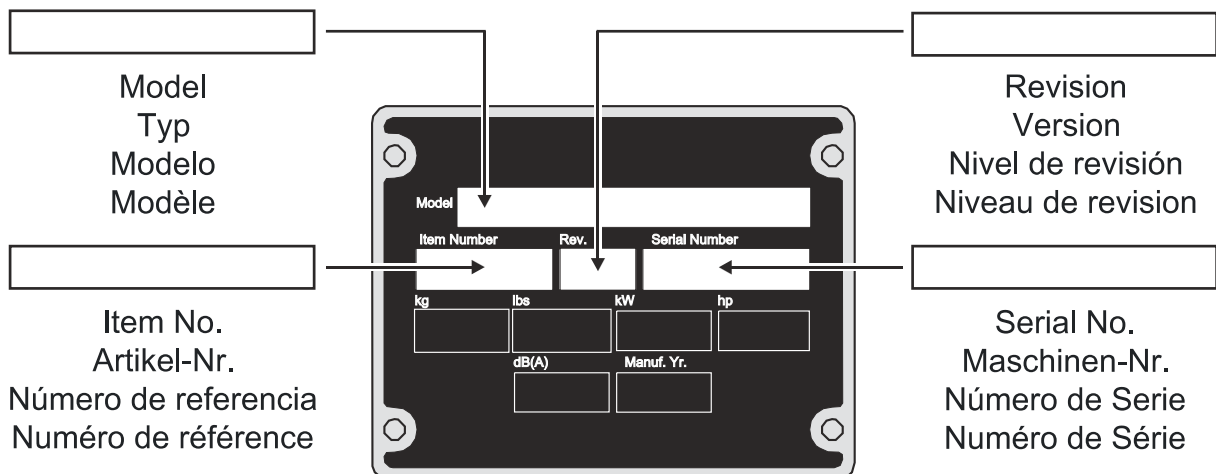

Part Numbers appearing in boldface type are recommended spare parts. This means that these parts are subject to wear under normal operating conditions and may require periodic service or replacement. It is recommended that these items be stocked to meet the expected service requirements of this model. Actual stocking quantities of these and other parts used in more extensive repairs will depend on the service practices of each customer.

Bei den in den Ersatzteillisten fettgedruckten Nummern handelt es sich um empfohlene Ersatzteile. Dies bedeutet, daß diese Teile bei normalen Anwendungsbedingungen natürlicher Abnutzung ausgesetzt sind und gelegentlich ersetzt oder überarbeitet werden müssen. Es wird geraten, diese Teile auf Lager bereit zu haben, um für Service-Arbeiten an diesem Gerät vorbereitet zu sein. Lagerbestände für diese und andere Teile, welche für ausgiebigere Reparaturarbeiten benötigt werden, können je nach Service-Gewohnheiten der einzelnen Kunden variieren.

Los números de partes en negritas en las Listas Ilustradas de Partes son los repuestos recomendados, ésto quiere decir que estas partes se desgastarán bajo circunstancias de funcionamiento normales y pueden requerir servicio periódico o su reemplazo. Se recomienda que el cliente mantenga un abastecimiento adecuado de estas partes para poder satisfacer la demanda requerida por el servicio a la máquina. La cantidad de repuestos que el cliente necesitará para reparaciones dependerá de la póliza de servicio de cada cliente.

Les numéros de pièces imprimés en caractères gras dans les Listes des Pièces Détachées de ce manuel sont les pièces détachées recommandées par la Wacker. Cela veut dire que ces pièces sont sujettes à usure dans des conditions de travail normales et peuvent nécessiter de l'entretien ou leur remplacement. Nous recommandons que vous disposez d'un stock de ces pièces pour pouvoir satisfaire la demande d'entretien de cette machine. Le client doit décider lui-même de la quantité exacte de pièces de rechange qu'il disposera dans ses stocks.

Engine Compartment Motorkasten Caja de Motor Boîte de Moteur	10
Front Frame Vorderrahmen Bastidor Delantero Châssis Avant	16
Rear Frame Hinterrahmen Bastidor de Atrás Châssis Arrière	22
Articulated Steering Joint Knickgelenk Unión Articulada de Dirección Joint articulé	26
Electric Equipment/Wiring Armaturen/Leitungen Equipo Eléctrico/Cables Équipement Électrique/Câblage	28
Hydraulic Piping Hydraulik-Rohrleitung Tubería Hidráulica Canalisation Hydraulique	32
Hydraulic Piping Hydraulik-Rohrleitung Tubería Hidráulica Canalisation Hydraulique	34
Front Cover Vorderdeckel Tapa delantera Couvercle avant	38
Rear Section/Controls Steuerkontrolle Sección Posterior/Palanca de Mando Partie Arrière/Guidons	40
Rear Cover Hinterdeckel Tapa de atrás Couvercle arrière	44
Drum Drive Bandagenantrieb Accionamiento de Tambor Entraînement de Tambour	46
Drum Drive w/Brake Bandagenantrieb mit Bremse Accionamiento de Tambor con Freno Entraînement de Tambour avec F	50
Front Drum Vorderbandage Tambor Delantero Tambour Avant	56
Rear Drum Hinterbandage Tambor de Atrás Tambour Arrière	58

Indice**Table des matières**

Exciter cpl. Erreger kpl. Excitador compl. Excitatrice compl.	60
Hydraulic Manifold Hydraulikverteiler Distribuidor Hidráulico Tubulure Hydraulique	62
Hydraulic Tank Hydrauliktank Tanque Hidráulico Réservoir Hydraulique	66
Transmitter Module Sender Transmisor Transmetteur	68
Labels Aufkleber Calcomanias Autocollants	70
Engine-Kohler Kohler-Motor Motor Kohler Moteur Kohler	73
Crankshaft Kurbelwelle Cigüeñal Vilebrequin	74
Piston/Connecting Rod Kolben/Pleuel Pistón/Biela Piston/Bielle	76
Flywheel Schwungrad Volante Volant	78
Pulley cpl. Scheibensatz Conjunto Cabrestante Ensemble Poulie	80
Cylinder Head Zylinderkopf Culata Culasse	82
Crankcase Kurbelgehäuse Cárter Carter	84
Cylinder Head Cover Zylinderkopfhaube Tapa del Cilindro Couvercle Supérieur	86
Flywheel Side Support Seite des Schwungrads Soporte del lado del volante m Volant moteur côté soutien	88

Fuel Injection System Kraftstoffeinspritzsystem Sistema de inyección de combustible Système d'Injection De Carbura	90
Camshaft Nockenwelle Arbol de levas Arbre à cames	94
Rocker Arms/Valves Kipphebel/Ventile Balancines/Válvulas Culbuteurs/Soupapes	96
Timing Gear Motorsteuerung Regulador Régulateur	98
Oil Pump Ölpumpe Bomba de Aceite Pompe à Huile	100
Oil Pan Ölwanne Colector de aceite Cuvette-carter à huile	102
Oil Filter Ölfiter Filtro de aceite Filtre d'huile	104
Oil Dipstick Ölpeilstab Indicador del nivel de aceite Réglette-jauge d'huile	106
Breather System Scheibensatz Conjunto Cabrestante Système de reniflard	108
Speed Governor Drehzahlregler Regulador de velocidad Régulateur de vitesse	110
Controls Steuerungen Mandos Commandes	112
Fuel Solenoid Kraftstoffsolenoid Solenoido de combustible Solénoïde à carburant	114
Fuel Filter Kraftstofffilter Filtro de Combustible Filtre à Carburant	116
Fuel Feed Pump Förderpumpe Bomba de Alimentación Pompe d'Alimentation	118

Indice**Table des matières**

Fuel Pipes Kraftstoffleitungen Tubos de Combustible Conduites de Carburant	120
Fan Gebläserad Ventilador Ventilateur	122
Temperature Sensor Temperatursensoreinheit Unidad de alerta de temperatura Appareil d'alerte de températu	124
Water Manifold Wasser-Verteiler Distribuidor del agua Rampe d'arrosage	126
Water Pump Wasserpumpe Bomba del agua Pompe à eau	128
Air Inlet Manifold Einlassluftleitblech Conducto de aire de entrada Canal d'air d'admission	130
Exhaust Manifold Auspuffkrümmer Distribuidor de escape Collecteur d'échappement	132
Voltage Regulator Spannungsregler Regulador de voltaje Régulateur de tension	134
Starter Motor Anlasser Motor de arranque Démarreur	136
Glow Plug Glühkerze Tapón luminoso Bougie de préchauffage	138
Hydraulic Pump Adapter Adapter für Hydraulikpumpe Adaptador para bomba hidráulica Raccord pour pompe hydraulique	140
Hydraulic Pump Adapter 2 Adapter für Hydraulikpumpe 2 Adaptador para bomba hidráulica 2 Raccord pour pompe hydraulique	142
Backplate Plattenrückwand Placa de atrás Plaque de fond	144
Beltguard Riemenschutz Guardacorrea Protection de courroie	146

Accessories Sonderzubehör Accesorios Accessoires	149
Smooth Drum Kit Bandagensatz (glatt) Juego de tambor (plano) Jeu de tambour (lisse)	150

Ref. Pos.	Part No. Artikel Nr.	Qty. St.	Description Beschreibung	Descripción Description	Measurement./Abm.	Norm
					Torque/Drehm.	Sealant Schmierstoff
200	5200022255	1	Engine-Kohler Kohler-Motor	Motor Kohler Moteur Kohler		
201	5200022250	1	Drive pump Antriebspumpe	Bomba de accionamiento Pompe d'entraînement		
202	5200022239	1	Exciter pump Erregerpumpe	Bomba del excitador Pompe de l'excitatrice		
203	5000119619	1	Adapter Adapter	Adaptador Raccord		
204	5000155487	1	Adaptor Adapter	Adaptador Adaptateur		
205	5000119695	1	Collar Hülse	Collar Douille		
206	5000150022	1	Cable Kabel	Cable Câble		
207	5000156315	1	Setscrew Gewindestift	Tornillo Vis	M6 x 10	
211	5000115877	1	Bracket Konsole	Soporte Support		
212	5000162855	1	Bracket Konsole	Soporte Support		
214	5000176114	1	Air cleaner Luftfilter	Filtro del aire Boîtier de filtre complet		
214	5000162184	1	Secondary element Sekundärelement	Elemento secundario Cartouche secondaire		
215	5000119582	1	Muffler Auspufftopf	Silenciador Pot d'échappement		
216	5000154686	1	Air cleaner bracket Luftfilterkonsole	Soporte de filtro del aire Support du filtre à air		
217	5000150293	1	Bracket Konsole	Soporte Support		
222	5000181844	1	Fuel filter w/water separator Kraftstofffilter mit Wasserabscheider	Filtro de combustible con dispositivo para separar Filtre de carburant avec purge		
555	5200025080	1	Engine control module Motorkontrollmodul	Módulo de mando del motor Module de contrôle de moteur		
566	5000085437	3	Relay Relais	Relai Relais		
574	5000150961	1	Circuit breaker Unterbrecher	Interruptor de circuito Coupe-circuit	50A 12V	
574	5000156190	1	Cover Deckel	Tapa Couvercle		
584	5000110557	1	Ground wire Erdungsdraht	Alambre a tierra Fil de masse	12in	
651	5000119929	1	Fitting cap Verschraubung, Kappe	Unión, tapa Raccord, Capuchon	No.8	
655	5000119906	1	Hose clamp Schlauchschelle	Abrazaderas de manguera Agrafe de tuyau	No.20 x 0,81 x 1,75in	
663	5000119937	1	Hose clamp Schlauchschelle	Abrazaderas de manguera Agrafe de tuyau	44	

Engine Compartment
Motorkasten
Caja de Motor
Boîte de Moteur

RTLx-SC3

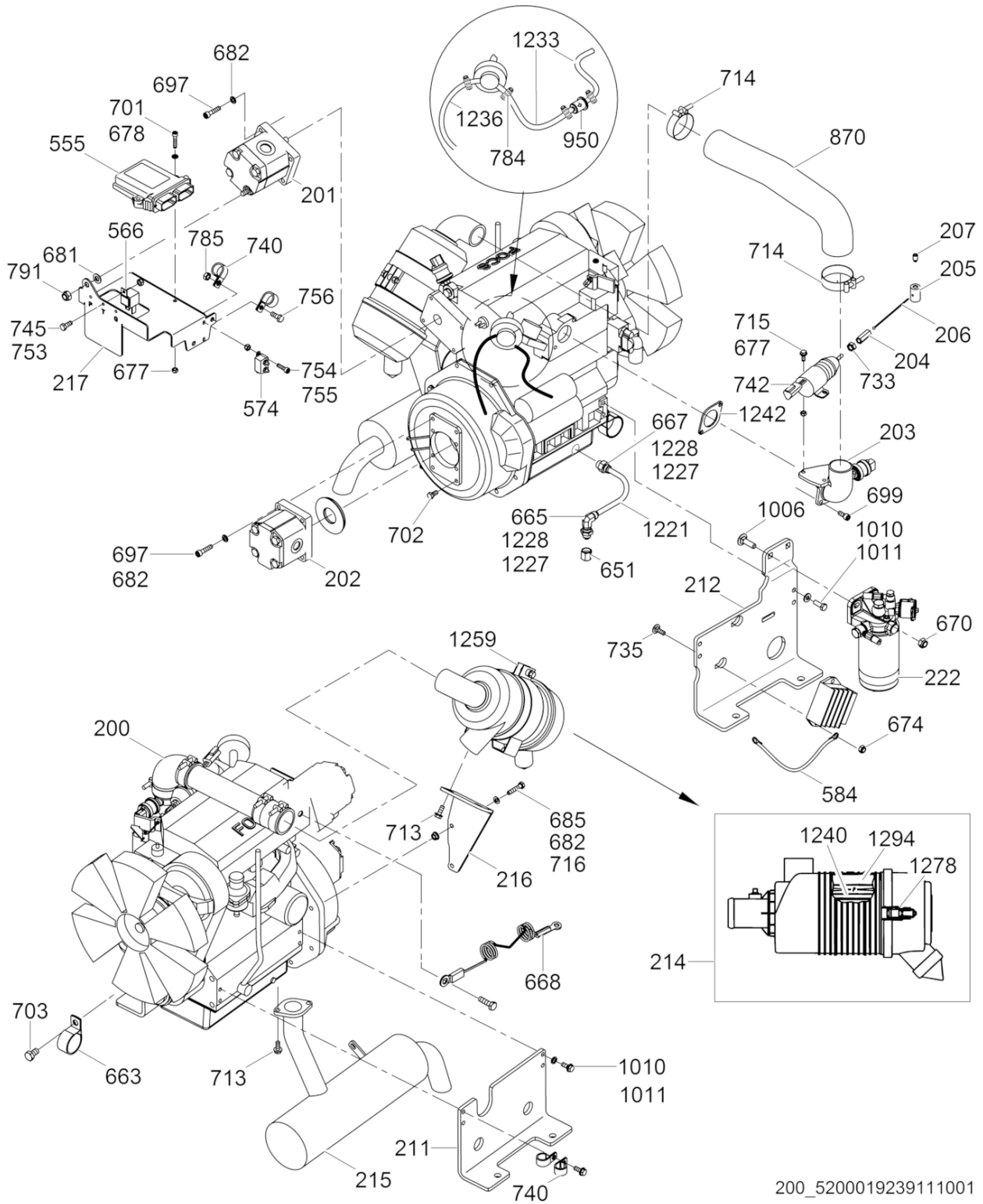

200_5200019239111001

Ref. Pos.	Part No. Artikel Nr.	Qty. St.	Description Beschreibung	Descripción Description	Measurement./Abm.	Norm
					Torque/Drehm.	Sealant Schmierstoff
665	5000119960	2	Fitting Verschraubung	Unión Raccord	No.8	
667	5000119962	2	Fitting Verschraubung	Unión Raccord	No.8	
668	5000154402	1	Cable Kabel	Cable Câble		
670	5000096087	2	Hexagon nut Sechskantmutter	Tuerca hexagonal Écrou hexagonal	M10	DIN 1661
674	5000010367	2	Hexagon nut Sechskantmutter	Tuerca hexagonal Écrou hexagonal	M8	DIN985
677	5000010368	4	Hexagon nut Sechskantmutter	Tuerca hexagonal Écrou hexagonal	M6	DIN985
678	5000010624	2	Flat washer Scheibe	Arandela Rondelle		
681	5000010621	1	Washer Scheibe	Arandela Rondelle		
682	5000010622	10	Flat washer Scheibe	Arandela Rondelle		
685	5000011341	2	Hexagonal head cap screw Sechskantschraube	Tornillo hexagonal Vis à tête hexagonale	M8 x 40 25Nm/18ft.lbs	DIN931 S3
690	5000011438	2	Hexagonal head cap screw Sechskantschraube	Tornillo hexagonal Vis à tête hexagonale	M10 x 35 49Nm/36ft.lbs	DIN933
697	5000011540	8	Cheese head screw Zylinderschraube	Tornillo cilíndrico Vis à tête cylindrique	M8 x 35 41Nm/30ft.lbs	ISO4762 S3
699	5000011543	2	Socket head screw Zylinderschraube	Tornillo hueco Vis à six-pans creux	M8 x 20 41Nm/30ft.lbs	ISO4762 S3
701	5000011549	2	Cheese head screw Zylinderschraube	Tornillo cilíndrico Vis à tête cylindrique	M6 x 30 17Nm/13ft.lbs	ISO4762
702	5000012361	2	Hexagonal head cap screw Sechskantschraube	Tornillo hexagonal Vis à tête hexagonale	M8 x 16 25Nm/18ft.lbs	DIN933 S3
703	5000012368	1	Hexagonal head cap screw Sechskantschraube	Tornillo hexagonal Vis à tête hexagonale	M12 x 20 86Nm/63ft.lbs	DIN933 S3
713	5000028404	4	Screw Schraube	Tornillo Vis	M8 x 20 34Nm/25ft.lbs	S3
714	5000028698	2	T-bolt clamp Schelle mit T-Bolzen	Abrazadera con perno forma T Agrafe avec boulon T	2-3/8in	
715	5000028949	2	Screw Schraube	Tornillo Vis	M6 x 16 10Nm/7ft.lbs	
716	5000030066	2	Locknut Sechskantmutter	Contratuerca Contre-écrou	M8	
733	5000010880	1	Hexagon nut Sechskantmutter	Tuerca hexagonal Écrou hexagonal		
735	5000111845	2	Carriage bolt Schloßschraube	Tornillo de carruaje Boulon brut à tête bombée	M8 x 25	
740	5000110458	4	Clamp Schelle	Abrazadera Agrafe		
742	5000155486	1	Throttle Actuator Gasreglerstellteil	Actuador de Acelerador Dispositif de commande des gaz		
745	5000011477	3	Hexagonal head cap screw Sechskantschraube	Tornillo hexagonal Vis à tête hexagonale	M5 x 12 6Nm/4ft.lbs	DIN933

Engine Compartment
Motorkasten
Caja de Motor
Boîte de Moteur

RTLx-SC3

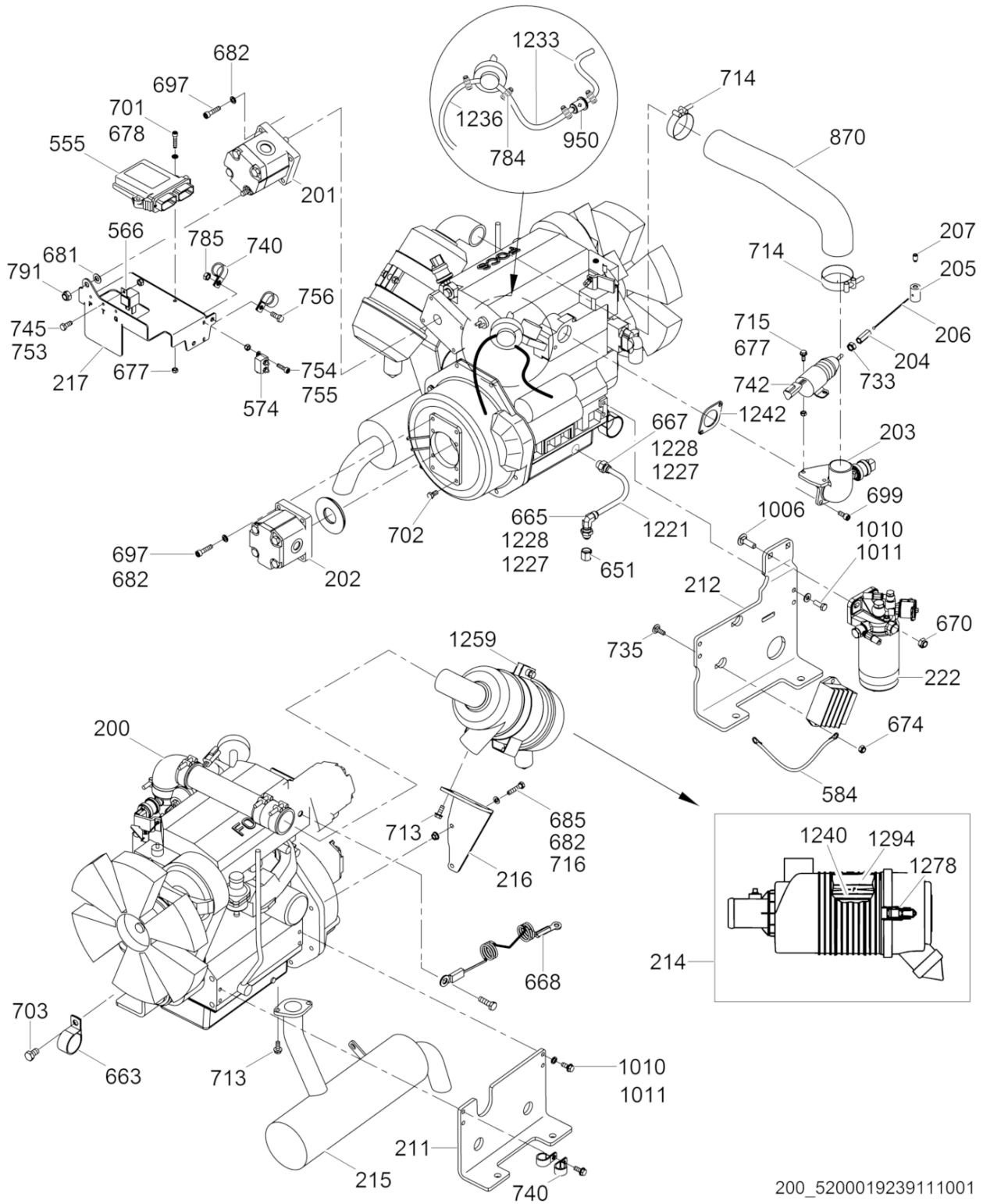

200_5200019239111001

Ref. Pos.	Part No. Artikel Nr.	Qty. St.	Description Beschreibung	Descripción Description	Measurement./Abm.	Norm
					Torque/Drehm.	Sealant Schmierstoff
753	5000010369	3	Hexagon nut Sechskantmutter	Tuerca hexagonal Écrou hexagonal		
754	5000011570	2	Cheese head screw Zylinderschraube	Tornillo cilíndrico Vis à tête cylindrique	5Nm/4ft.lbs	
755	5000010370	1	Hexagon nut Sechskantmutter	Tuerca hexagonal Écrou hexagonal		
756	5000012362	2	Hexagonal head cap screw Sechskantschraube	Tornillo hexagonal Vis à tête hexagonale	25Nm/18ft.lbs	
784	5000028707	6	Clamp Schelle	Abrazadera Agrafe	0,21-0,63	
785	5000010882	1	Hexagon nut Sechskantmutter	Tuerca hexagonal Écrou hexagonal		
791	5000010365	1	Lock nut Sicherungsmutter	Contratuerca Contre-écrou	M10	DIN980
870	5000164861	1	Intake manifold hose Einlasskrümmerschlauch	Manguera del distribuidor de admisión Tuyau de collecteur d'admissio		
950	5000112497	1	Fuel filter Kraftstofffilter	Filtro de combustible Filtre à carburant		
1006	5000162829	2	Carriage bolt Schloßschraube	Tornillo de carruaje Boulon brut à tête bombée	M10 x 35	DIN603
1010	5000165460	8	Hexagonal head cap screw Sechskantschraube	Tornillo hexagonal Boulon à tête hexagonale	M8 x 22, 10.9 31Nm/23ft.lbs	S3
1011	5000033198	8	Lockwasher Spannscheibe	Arandela elástica Rondelle de ressort	8	DIN6796
1221	5000119683	1	Hydraulic hose Hydraulikschlauch	Manguera hidráulica Tuyau hydraulique	380	
1227	5000080737	2	O-Ring O-Ring	Anillo-O Joint torique	0,489 x 0,070in	
1228	5000080732	2	O-Ring O-Ring	Anillo-O Joint torique	0,644 x 0,087in	
1233	5000183205	1	Fuel hose Kraftstoffleitung	Manguera de combustible Tuyau de carburant	3/16 ID x 46,60in	
1236	5000159556	1	Fuel hose Kraftstoffleitung	Manguera de combustible Tuyau de carburant	1/4 x 75,6in	
1240	5000160171	1	Filter insert Filtereinsatz	Cartucho filtrante Element filtrant		
1242	5000159294	1	Gasket Dichtung	Junta de estanqueidad Garniture		
1259	5000164069	2	Air filter bracket Luftfilterkonsole	Soporte de filtro del aire Support du filtre à air		
1278	5000171456	2	Clamp Klemme	Abrazaderaro de aire Pince		
1294	5000162184	1	Secondary element Sekundärelement	Elemento secundario Cartouche secondaire		

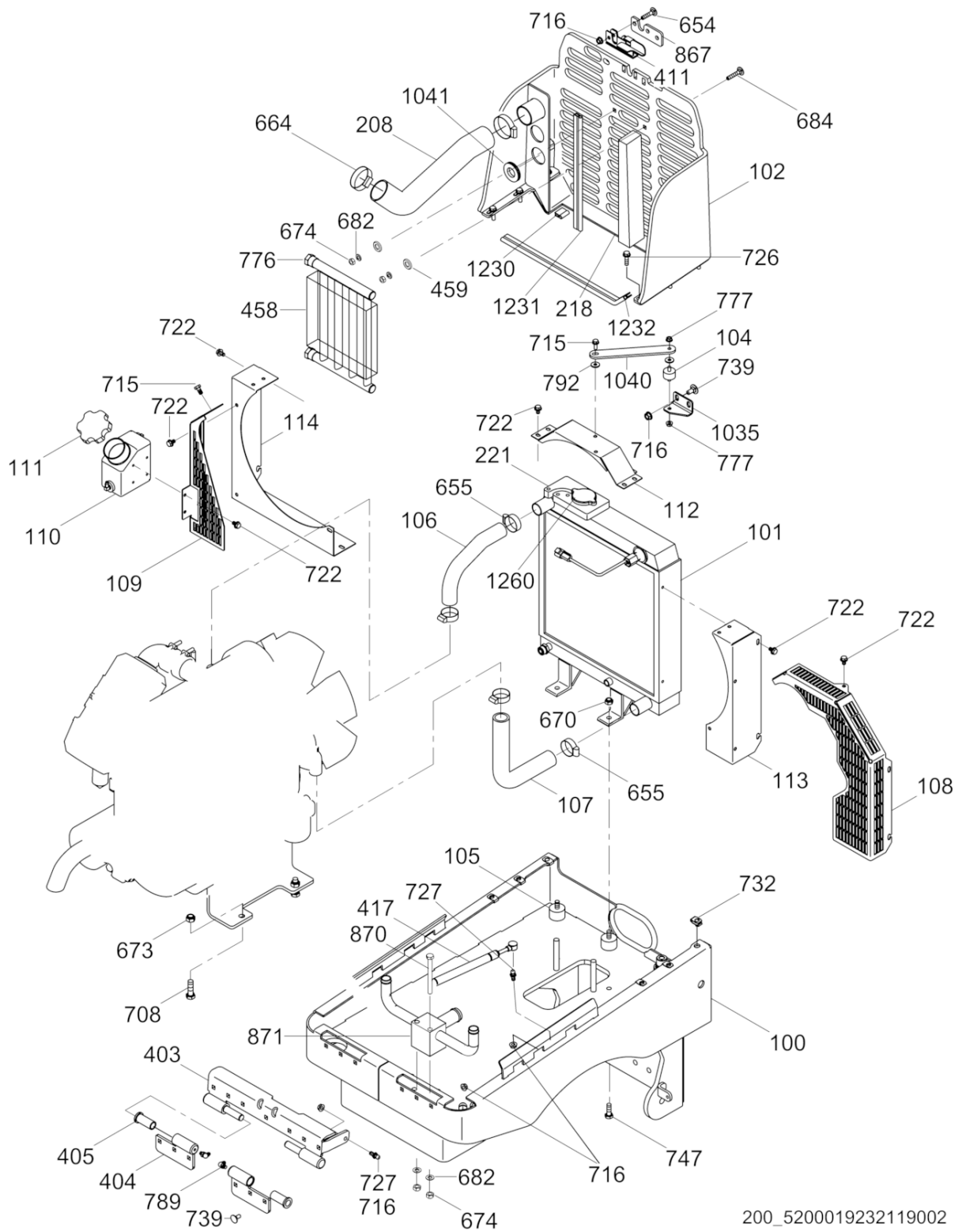

200_5200019232119002

Ref. Pos.	Part No. Artikel Nr.	Qty. St.	Description Beschreibung	Descripción Description	Measurem./Abm.	Norm
					Torque/Drehm.	Sealant Schmierstoff
100	5000116471	1	Front frame Vorderrahmen	Chasis delantero Châssis avant		
101	5000154348	1	Radiator Kühler	Radiador Radiateur		
102	5000177118	1	Radiator guard Kühlerschutzbügel	Guardarradiador Pare-chocs de radiateur		
104	5000150205	1	Shockmount Puffer	Amortiguador Silentbloc	25 x 19-60 Sh	
105	5000150206	2	Shockmount Puffer	Amortiguador Silentbloc	38,1 x 25,4-60 Sh	
106	5000155119	1	Radiator top hose Oberkühlwasserschlauch	Manguera superior del radiador Tuyau supérieur du radiateur		
107	5000155120	1	Radiator bottom hose Unterkühlwasserschlauch	Manguera inferior del radiador Tuyau inférieur du radiateur		
108	5000155121	1	Guard Schutz	Protector Protection		
109	5000155128	1	Guard Schutz	Protector Protection		
110	5000157209	1	Bottle-overflow Überlaufflasche	Botella de rebose Bouteille de trop-plein		
111	5000157255	1	Cap Kappe	Tapa Couvercle		
112	5000156236	1	Cover Deckel	Tapa Couvercle		
113	5000156238	1	Cover Deckel	Tapa Couvercle		
114	5000156240	1	Cover Deckel	Tapa Couvercle		
208	5000156131	1	Hose Schlauch	Manguera Tuyau		
218	5000150225	1	Seal Dichtung	Empaque Joint		
221	5000150228	1	Seal Dichtung	Empaque Joint		
403	5000119984	1	Pin Stift	Pasador Goupille		
404	5000181474	2	Hinge Scharnier	Bisagra Charnière		
405	5000164540	2	Bushing spacer Abstandshülse	Espaciador Entretoise		
411	5000150098	1	Latch Verriegelung	Aldaba Loquet		
417	5000150104	1	Cylinder Zylinder	Cilindro Cylindre		
458	5200024880	1	Radiator Kühler	Radiador Radiateur		
459	5000045719	4	Flat washer Scheibe	Arandela Rondelle	8,4	DIN7349
652	5000157166	7	Carriage bolt Schloßschraube	Tornillo de carruaje Boulon brut à tête bombée	M8 x 45	

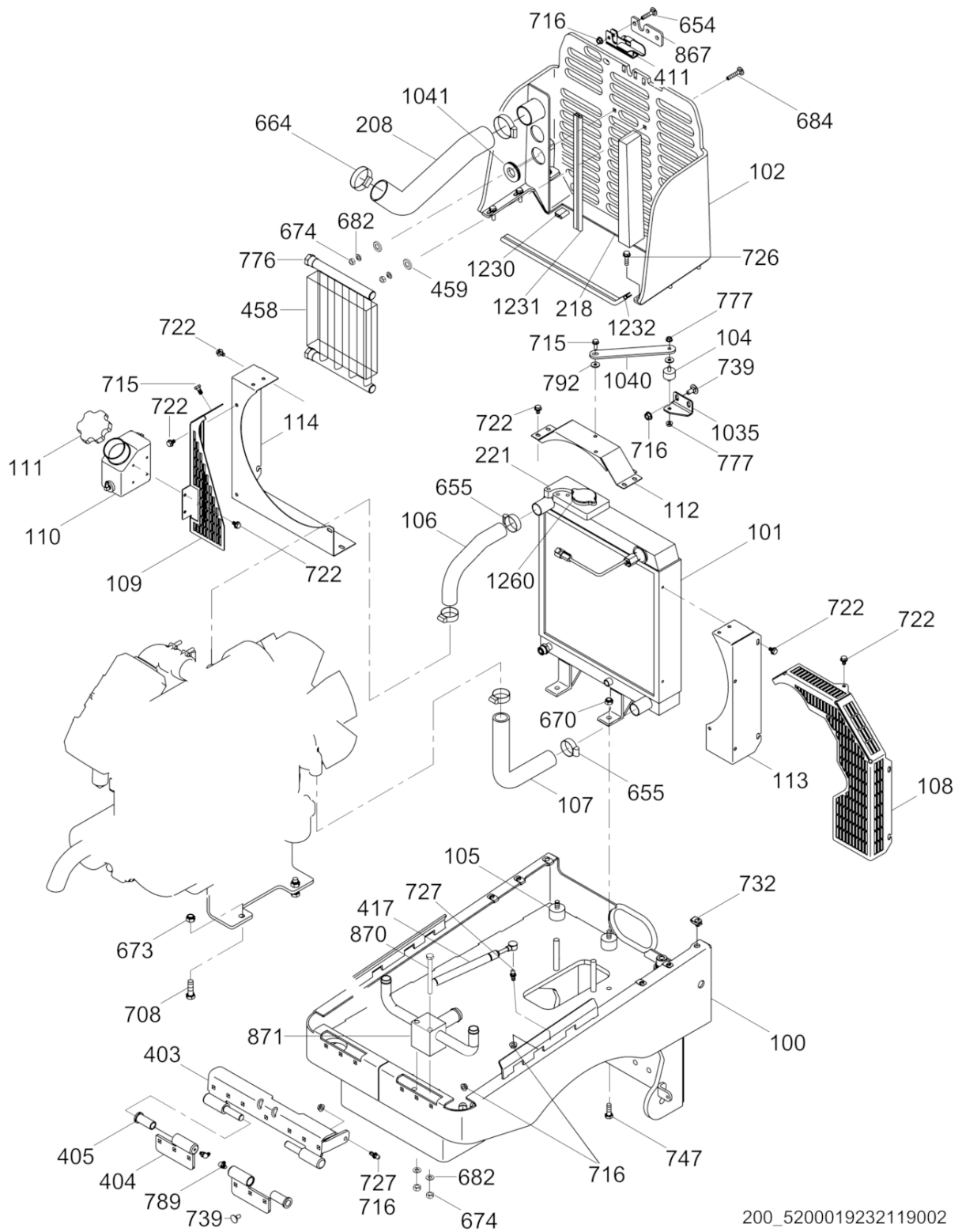

200_5200019232119002

Ref. Pos.	Part No. Artikel Nr.	Qty. St.	Description Beschreibung	Descripción Description	Measurem./Abm.	Norm
					Torque/Drehm.	Sealant Schmierstoff
655	5000119906	4	Hose clamp Schlauchschele	Abrazaderas de manguera Agrafe de tuyau	No.20 x 0,81 x 1,75in	
664	5000119938	2	Hose clamp Schlauchschele	Abrazaderas de manguera Agrafe de tuyau	No.32	
670	5000010365	2	Lock nut Sicherungsmutter	Contratuerca Contre-écrou	M10	DIN980
673	5000010366	4	Hexagon nut Sechskantmutter	Tuerca hexagonal Écrou hexagonal	M12X1.75	DIN985
674	5000011310	6	Hexagonal head cap screw Sechskantschraube	Tornillo hexagonal Vis à tête hexagonale	M8 x 85 25Nm/18ft.lbs	DIN931
682	5000010622	12	Flat washer Scheibe	Arandela Rondelle		
684	5000011151	4	Carriage bolt Schloßschraube	Tornillo de carruaje Boulon brut à tête bombée	M8 x 30	DIN603
708	5000016434	4	Screw Schraube	Tornillo Vis	M12 x 40 120Nm/89ft.lbs	
715	5000028949	2	Screw Schraube	Tornillo Vis	M6 x 16 10Nm/7ft.lbs	
716	5000030066	13	Locknut Sechskantmutter	Contratuerca Contre-écrou	M8 7Nm/5ft.lbs	
722	5000073164	14	Hexagonal flange head screw Sechskantflanschschaube	Tornillo hexagonal de brida Vis hexagonale de bride	M6 x 10 10Nm/7ft.lbs	
726	5000085957	6	Screw Schraube	Tornillo Vis	M8 x 30 25Nm/18ft.lbs	
727	5000155125	2	Stud Gewindebolzen	Perno prisionero Goujon	M8 x 10	
732	5000110969	6	Clip nut Klemmutter	Sujetador Agrafe	M8	
739	5000155841	8	Carriage bolt Schloßschraube	Tornillo de carruaje Boulon brut à tête bombée	M8 x 20	
747	5000012364	2	Hexagonal head cap screw Sechskantschraube	Tornillo hexagonal Vis à tête hexagonale	M10 x 20 49Nm/36ft.lbs	DIN933 S3
776	5000081583	2	Straight fitting Verschraubung-gerade	Unión recto Raccord-droit	No.8	
777	5000029117	2	Lock nut Sicherungsmutter	Contratuerca Contre-écrou	M6	
785	5000010882	2	Hexagon nut Sechskantmutter	Tuerca hexagonal Écrou hexagonal		
789	5000114393	2	Grease fitting Schmiernippel	Grasera Graisseur	M6 x 1	
792	5000010373	2	Flat washer Scheibe	Arandela Rondelle	6	ISO7093
867	5000160294	1	Spacer Abstandsstück	Espaciador Entretoise		
871	5000181897	1	Suction manifold Saugverteiler	Distribuidor de succión Collecteur d'aspiration		
1035	5000163899	1	Bracket Konsole	Soporte Support		
1040	5000163898	1	Radiator bracket Kühlerträger	Soporte del radiador Support de radiateur		

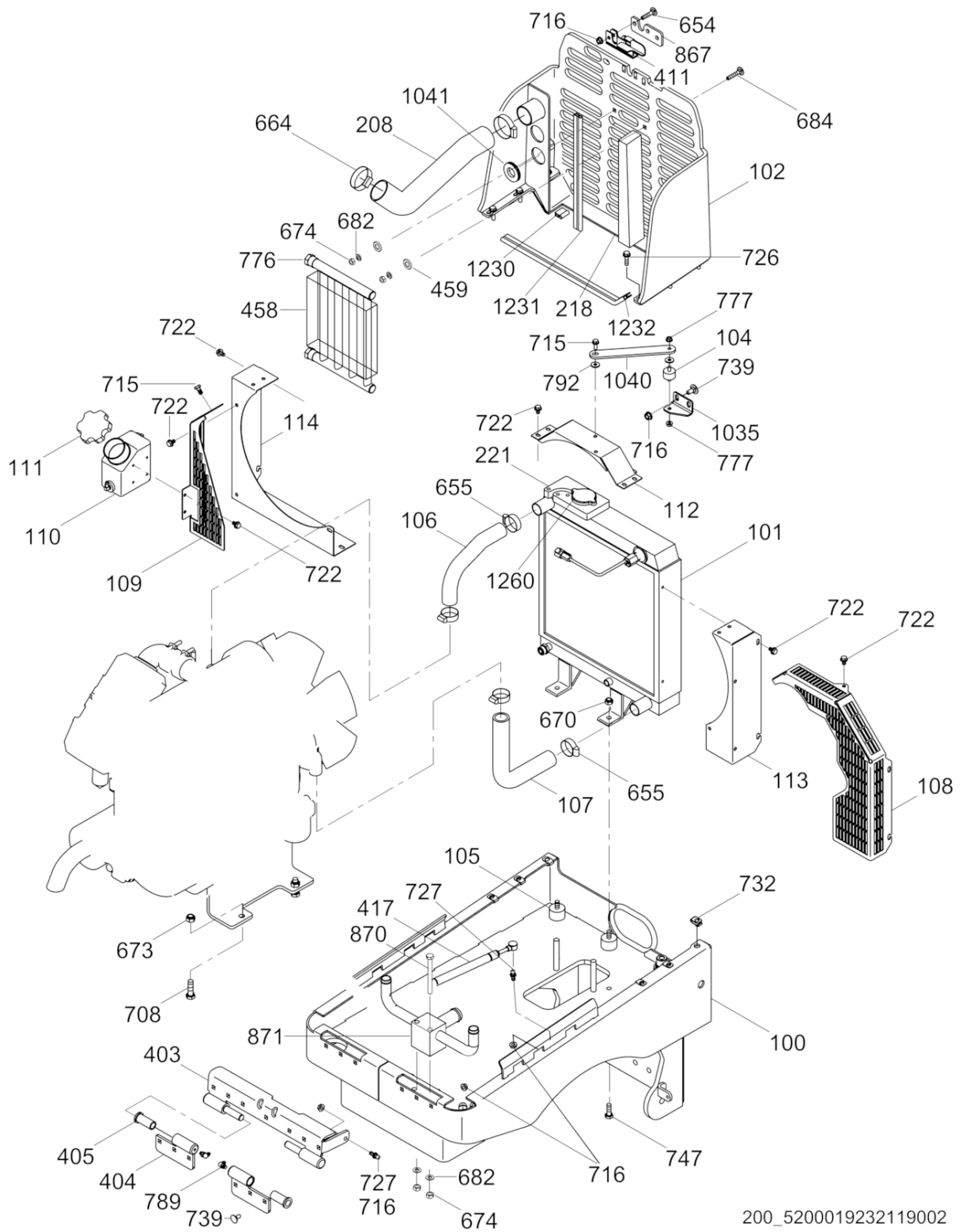

200_5200019232119002

Ref. Pos.	Part No. Artikel Nr.	Qty. St.	Description Beschreibung	Descripción Description	Measurement./Abm.	Norm
					Torque/Drehm.	Sealant Schmierstoff
1041	5000163464	2	Grommet Tülle	Ojal Passe-fil	1 x 1-3/4 x 1/4in	
1230	5000159559	1	Seal-trim Profilgummi	Moldura Garniture	1.0in	
1231	5000159560	1	Seal-trim Profilgummi	Moldura Garniture	17in	
1232	5000159561	1	Seal-trim Profilgummi	Moldura Garniture	1000	
1260	5000164350	1	Radiator cap Kühlerverschlußdeckel	Tapa del radiador Couvercle du radiateur		

Rear Frame
Hinterrahmen
Bastidor de Atrás
Châssis Arrière

RTLx-SC3

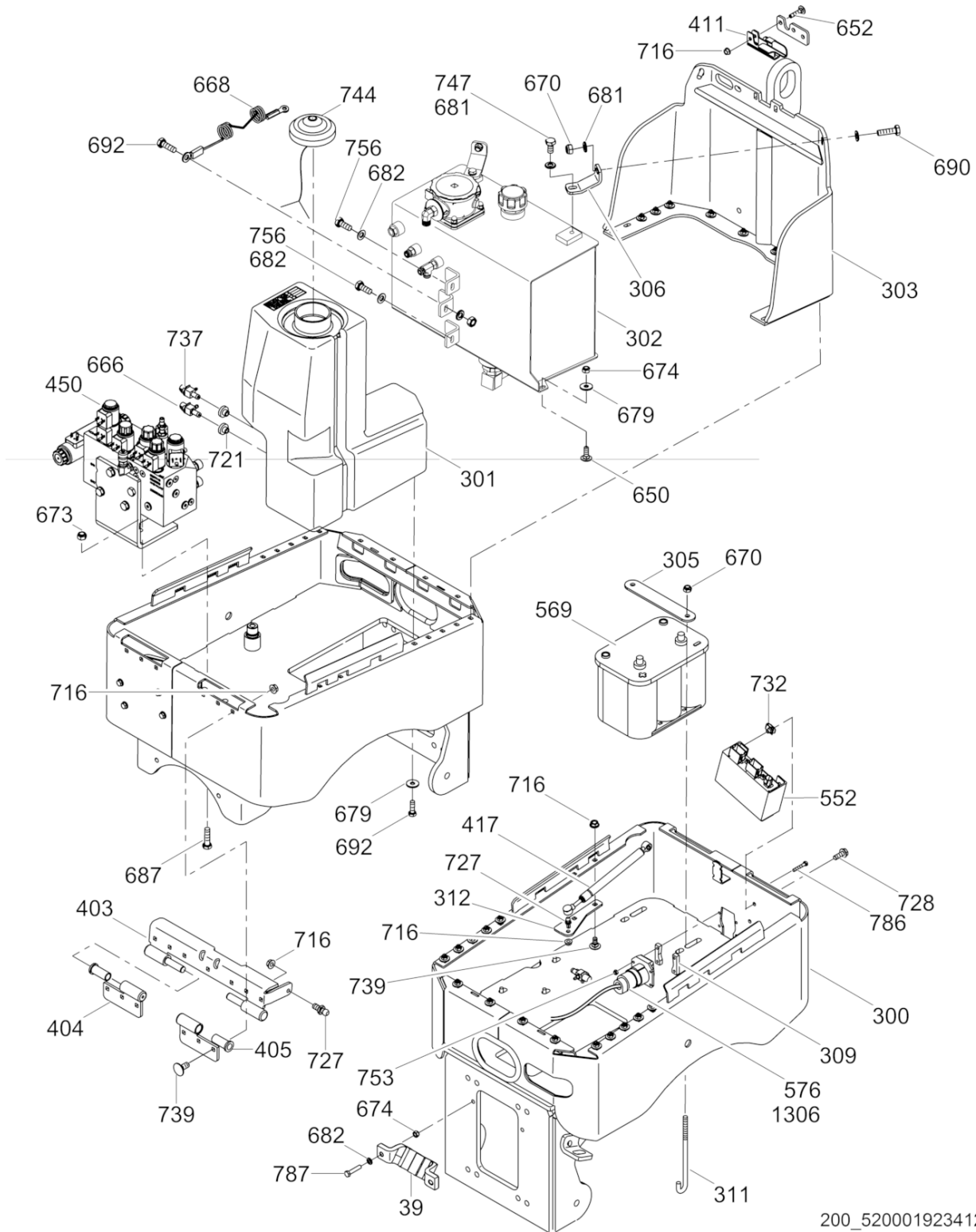

200_5200019234120003

Ref. Pos.	Part No. Artikel Nr.	Qty. St.	Description Beschreibung	Descripción Description	Measurement./Abm.	Norm
					Torque/Drehm.	Sealant Schmierstoff
39	5100035870	1	Hose guide bracket Schlauchführungshalter	Support de guidage de tuyau Soporte de la manguera		
300	5000117176	1	Rear frame Hinterrahmen	Chasis de atrás Châssis arrière		
301	5000153625	1	Fuel tank Kraftstofftank	Depósito de combustible Réservoir de carburant		
302	5200000844	1	Hydraulic tank Hydrauliktank	Tanque hidráulico Réservoir hydraulique		
303	5000150089	1	Housing Gehäuse	Caja Carter		
305	5000152305	1	Plate Platte	Placa Plaque		
306	5000154260	1	Bracket Konsole	Soporte Support		
309	5000154751	1	Spacer Abstandsstück	Espaciador Entretoise		
311	5000156164	2	Rod Stange	Varilla Tringle		
312	5000154712	1	Bracket Konsole	Soporte Support		
403	5000119984	1	Pin Stift	Pasador Goupille		
404	5000181474	2	Hinge Scharnier	Bisagra Charnière		
405	5000164540	2	Bushing spacer Abstandshülse	Espaciador Entretoise		
411	5000150098	1	Latch Verriegelung	Aldaba Loquet		
417	5000150104	1	Cylinder Zylinder	Cilindro Cylindre		
450	5200025568	1	Hydraulic manifold Hydraulikverteiler	Distribuidor hidráulico Tubulure hydraulique		
552	5000165515	1	Decoder module Decodiermodul	Módulo decodificador Module de décodage		
569	5000165552	1	Battery Batterie	Batería Batterie	12V	
576	5000170950	1	Plug and harness cpl. Stecker und Kabelbaum kpl.	Enchufe y conjunto de cables compl. Fiche et harnais de câbles éle		
650	5000157165	14	Carriage bolt Schloßschraube	Tornillo de carruaje Boulon brut à tête bombée	M8 X 25 8,8	
652	5000157166	3	Carriage bolt Schloßschraube	Tornillo de carruaje Boulon brut à tête bombée	M8 x 45	
666	5000119927	1	Fitting Verschraubung	Unión Raccord	1/4in	
668	5000154402	1	Cable Kabel	Cable Câble		
670	5000010365	4	Lock nut Sicherungsmutter	Contratuerca Contre-écrou	M10	DIN980
673	5000010366	4	Hexagon nut Sechskantmutter	Tuerca hexagonal Écrou hexagonal	M12X1.75	DIN985

Rear Frame
Hinterrahmen
Bastidor de Atrás
Châssis Arrière

RTLx-SC3

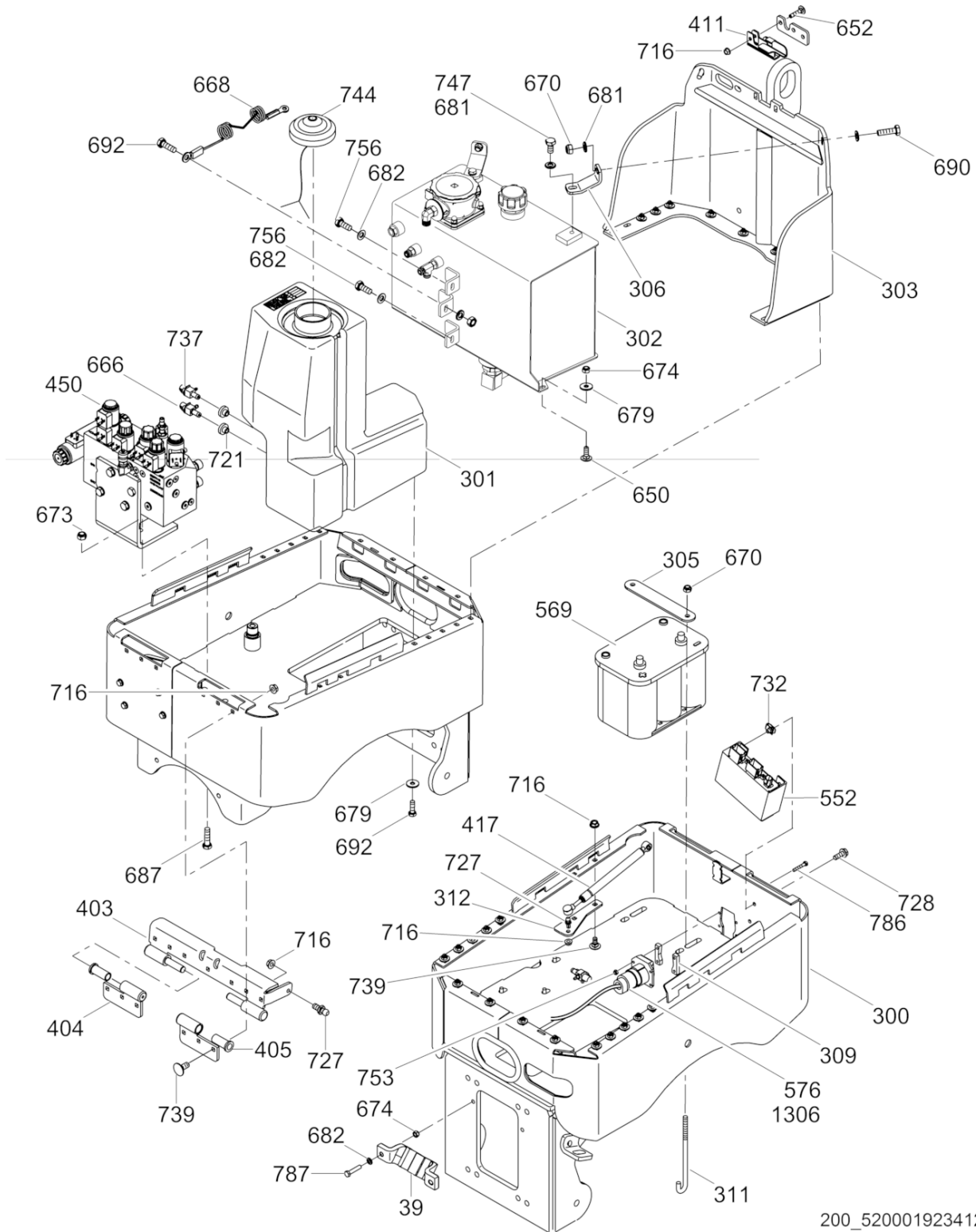

200_5200019234120003

Ref. Pos.	Part No. Artikel Nr.	Qty. St.	Description Beschreibung	Descripción Description	Measurement./Abm.	Norm
					Torque/Drehm.	Sealant Schmierstoff
674	5000010367	2	Hexagon nut Sechskantmutter	Tuerca hexagonal Écrou hexagonal	M8	DIN985
679	5000160298	6	Flat washer Scheibe	Arandela elástica Rondelle de ressort	B8.4	
681	5000010621	6	Washer Scheibe	Arandela Rondelle		
682	5000010622	4	Flat washer Scheibe	Arandela Rondelle		
687	5000011420	4	Hexagonal head cap screw Sechskantschraube	Tornillo hexagonal Vis à tête hexagonale	M12 x 45 86Nm/63ft.lbs	DIN933
690	5000011438	2	Hexagonal head cap screw Sechskantschraube	Tornillo hexagonal Vis à tête hexagonale	M10 x 35 49Nm/36ft.lbs	DIN933
692	5000011457	6	Hexagonal head cap screw Sechskantschraube	Tornillo hexagonal Vis à tête hexagonale	M8 x 25 7Nm/5ft.lbs	DIN933 S3
716	5000030066	12	Locknut Sechskantmutter	Contratuerca Contre-écrou	M8 7Nm/5ft.lbs	
721	5000053577	2	Tank valve bushing Tankbuchse	Buje Douille		
727	5000155125	2	Stud Gewindebolzen	Perno prisionero Goujon	M8 x 10	
728	5000087023	4	Hexagonal flange head screw Sechskantflanschschaube	Tornillo hexagonal de brida Vis hexagonale de bride	M8 x 22 25Nm/18ft.lbs	
732	5000110969	4	Clip nut Klemmutter	Sujetador Agrafe	M8	
737	5000157189	1	Valve Ventil	Válvula Soupape	3/16in	
739	5000155841	8	Carriage bolt Schloßschraube	Tornillo de carruaje Boulon brut à tête bombée	M8 x 20	
744	5000118640	1	Fuel tank cap Tankverschluss	Tapa del tanque Chapeau de réservoir		
747	5000012364	1	Hexagonal head cap screw Sechskantschraube	Tornillo hexagonal Vis à tête hexagonale	M10 x 20 49Nm/36ft.lbs	DIN933 S3
753	5000010369	4	Hexagon nut Sechskantmutter	Tuerca hexagonal Écrou hexagonal		
756	5000012362	2	Hexagonal head cap screw Sechskantschraube	Tornillo hexagonal Vis à tête hexagonale	7Nm/5ft.lbs	
786	5000154898	4	Hexagonal head cap screw Sechskantschraube	Tornillo hexagonal Boulon à tête hexagonale	M5 x 30	
867	5000160294	1	Spacer Abstandsstück	Espaciador Entretoise		
1306	5000182304	1	Connector Anschlußteil	Conector Connecteur		

Articulated Steering Joint
Knickgelenk
Unión Articulada de Dirección
Joint articulé

RTLx-SC3

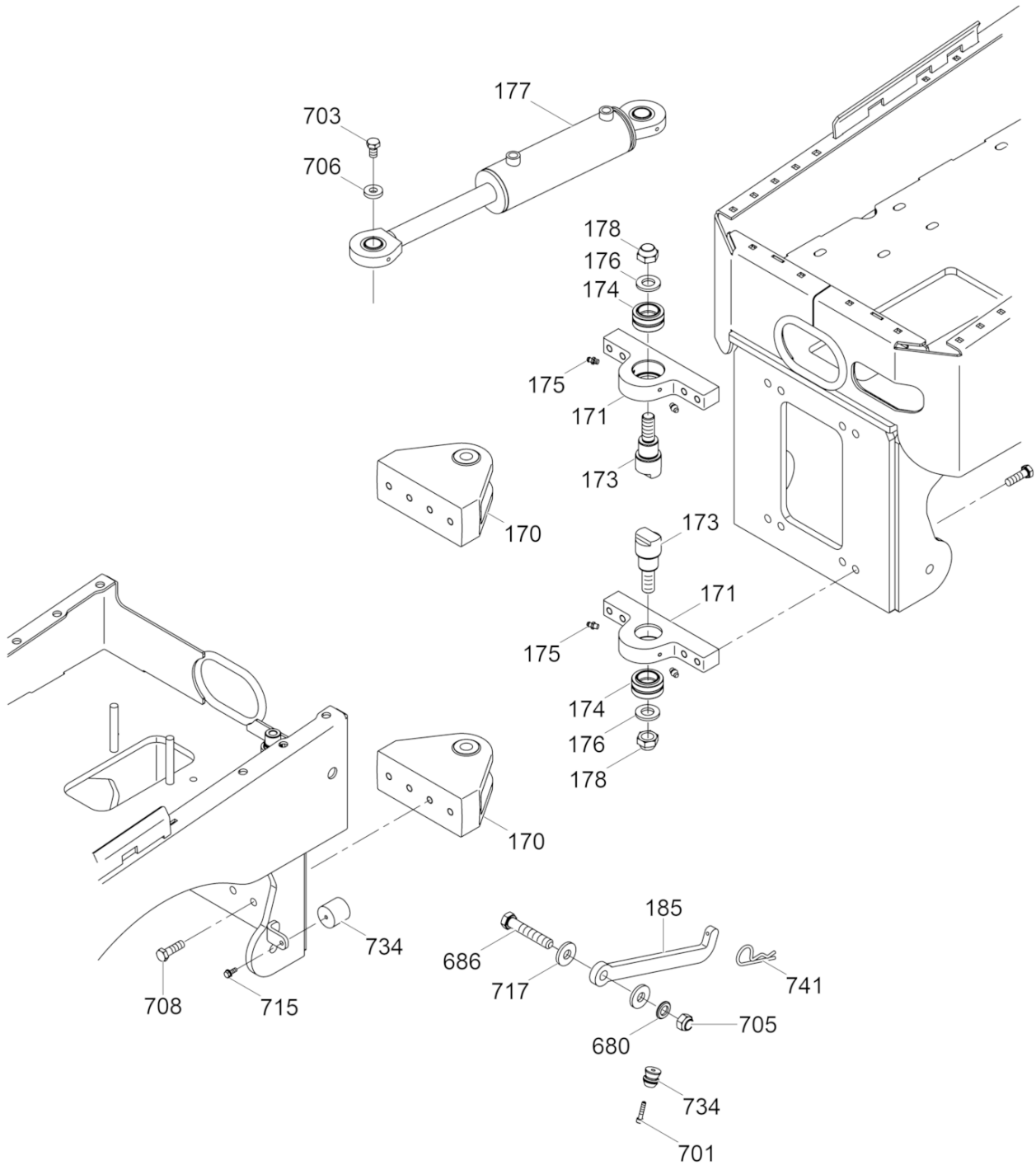

wc_ex0009025100_04

Ref. Pos.	Part No. Artikel Nr.	Qty. St.	Description Beschreibung	Descripción Description	Measurem./Abm.	Norm
					Torque/Drehm.	Sealant Schmierstoff
170	5000115448	2	Pivot Drehteil	Pivote Pivot		
171	5000089323	2	Bracket Konsole	Soporte Support		
173	5000119066	2	Pin Stift	Pasador Goupille		
174	5000079161	2	Ball bearing Kugellager	Rodamiento de bolas Roulement à billes		
175	5002004705	4	Grease fitting Kegelschmiernippel	Grasera Graisseur	AM6	DIN71412
176	5000119067	2	Washer Scheibe	Arandela Rondelle		
177	5000117018	1	Hydraulic cylinder Hydrozylinder	Cilindro hidráulico Cylindre hydraulique		
178	5000017088	2	Lock nut Sicherungsmutter	Contratuercas Contre-écrou	M20	
185	5000119629	1	Lock arm Riegel	Seguro Verrou		
680	5000010618	1	Flat washer Scheibe	Arandela Rondelle	16	ISO7090
686	5000011382	1	Hexagonal head cap screw Sechskantschraube	Tornillo hexagonal Vis à tête hexagonale	M16 x 90 210Nm/155ft.lbs	DIN931
701	5000011549	1	Cheese head screw Zylinderschraube	Tornillo cilíndrico Vis à tête cylindrique	M6 x 30 17Nm/13ft.lbs	ISO4762
703	5000012368	2	Hexagonal head cap screw Sechskantschraube	Tornillo hexagonal Vis à tête hexagonale	M12 x 20 86Nm/63ft.lbs	DIN933 S3
705	5000011382	1	Hexagonal head cap screw Sechskantschraube	Tornillo hexagonal Vis à tête hexagonale	M16 x 90 210Nm/155ft.lbs	DIN931
706	5000013618	2	Flat washer Scheibe	Arandela Rondelle	13	DIN7349
708	5000016434	16	Screw Schraube	Tornillo Vis	M12 x 40 86Nm/63ft.lbs	
715	5000028949	1	Screw Schraube	Tornillo Vis	M6 x 16 10Nm/7ft.lbs	
717	5000031121	2	Washer Scheibe	Arandela Rondelle		
734	5000111536	1	Latch Verriegelung	Aldaba Loquet		
741	5002005276	1	Cotter pin Splint	Clavija hendida Goupille fendue	No.3-9/16in	
1274	5000165049	1	Hose guard Schlauchschutz	Protector de manguera Protecteur		

Electric Equipment/Wiring
Armaturen/Leitungen
Equipo Eléctrico/Cables
Équipement Électrique/Câblage

RTLx-SC3

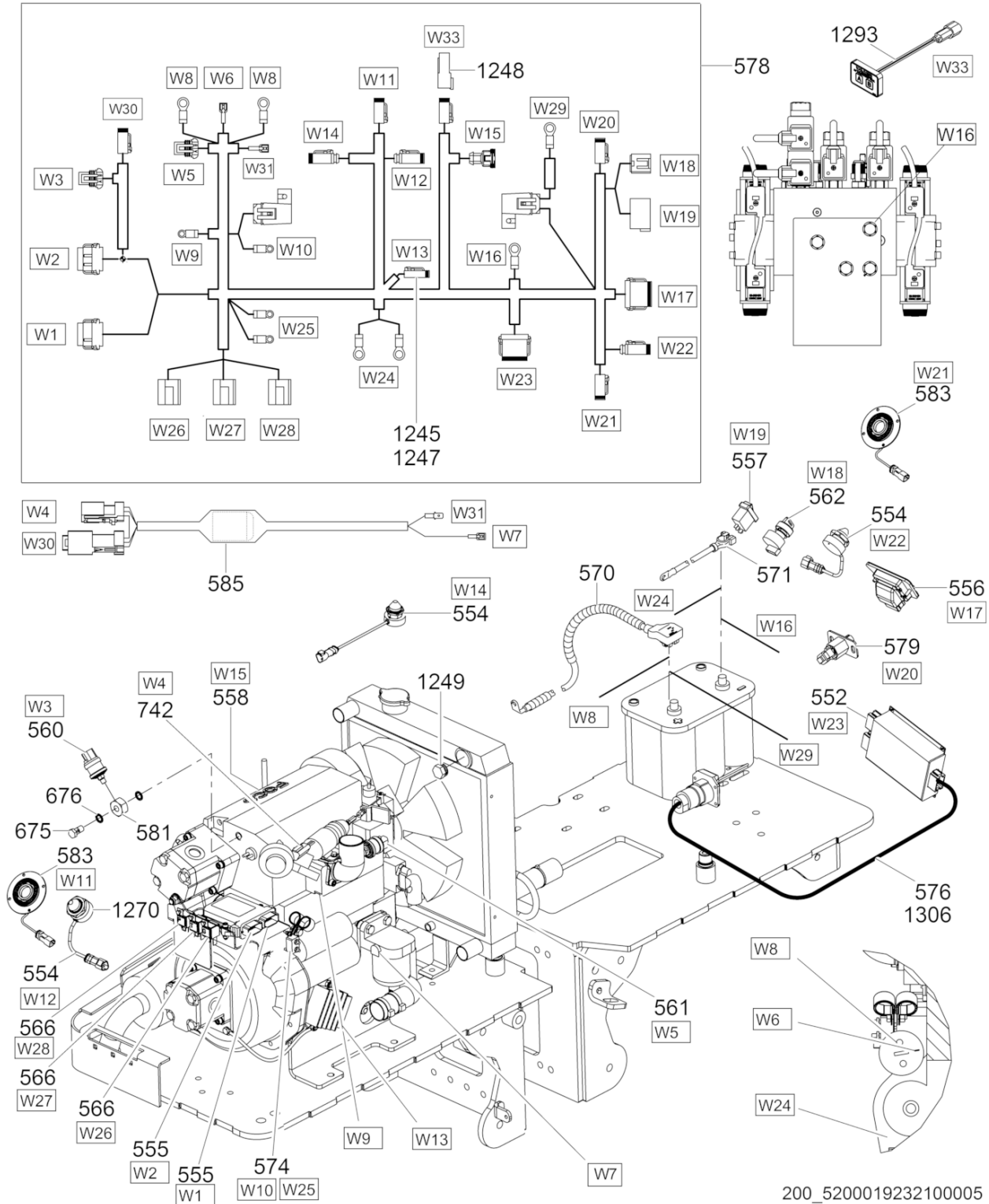

200_520001923210005

Ref. Pos.	Part No. Artikel Nr.	Qty. St.	Description Beschreibung	Descripción Description	Measur./Abm.	Norm
					Torque/Drehm.	Sealant Schmierstoff
552	5000165515	1	Decoder module Decodiermodul	Módulo decodificador Module de décodage		
554	5000170949	3	Infrared sensor Empfängerauge	Receptor de rayos Oeil récepteur		
555	5200025080	1	Engine control module Motorkontrollmodul	Módulo de mando del motor Module de contrôle de moteur		
556	5000178862	1	Display module Anzeigemodul	Módulo de visualización Module d'affichage		
557	5000150110	1	Switch Schalter	Interruptor Interrupteur		
558	5000160387	1	Sensor Sensoreinheit	Unidad de alerta Appareil d'alerte		
560	5000150113	1	Oil pressure switch Öldruckschalter	Interruptor de presión de aceite Interrupteur à pression d'huile		
561	5000150114	1	Vacuum switch Vakuumschalter	Interruptor Interrupteur à vide		
562	5000150115	1	Ignition switch Zündschalter	Interruptor de encendido Interrupteur d'ignition		
566	5000085437	3	Relay Relais	Relai Relais		
570	5000119292	1	Positive battery cable Plusbatteriekabel	Cable positivo de batería Câble positif de batterie		
571	5000119293	1	Negative battery cable Minusbatteriekabel	Cable negativo de batería Câble négatif de batterie		
574	5000150961	1	Circuit breaker Unterbrecher	Interruptor de circuito Coupe-circuit	50A 12V	
576	5000170950	1	Plug and harness cpl. Stecker und Kabelbaum kpl.	Enchufe y conjunto de cables compl. Fiche et harnais de câbles éle		
578	5200020490	1	Wiring harness Kabelbaum	Conjunto de cables Harnais de câbles électriques		
579	5000154405	1	Charge port module Ladungsanschlussmodul	Módulo de toma de carga Module de prise de charge		
581	5000150291	1	Adapter Adapter	Adaptador Raccord		
583	5000154403	2	Light ring module Lichtringmodul	Módulo de anillo de luz Module de l'anneau lumineux		
585	5100031355	1	Wiring harness Kabelbaum	Conjunto de cables Harnais de câbles électriques		
585	5000170174	1	Wiring harness Kabelbaum	Conjunto de cables Harnais de câbles électriques		
675	5000150116	1	Bolt Bolzen	Perno Boulon	M12	
676	5000150117	2	Washer Scheibe	Arandela Rondelle	M12	
742	5000155486	1	Throttle Actuator Gasreglerstellteil	Actuador de Acelerador Dispositif de commande des gaz		
1245	5000160840	1	Connector housing, 2 pole,plug 2-Pol Stecker	Enchufe Fiche		
1246	5000160841	2	Receptacle connector Steckdose	Tomacorriente Prise de courant		

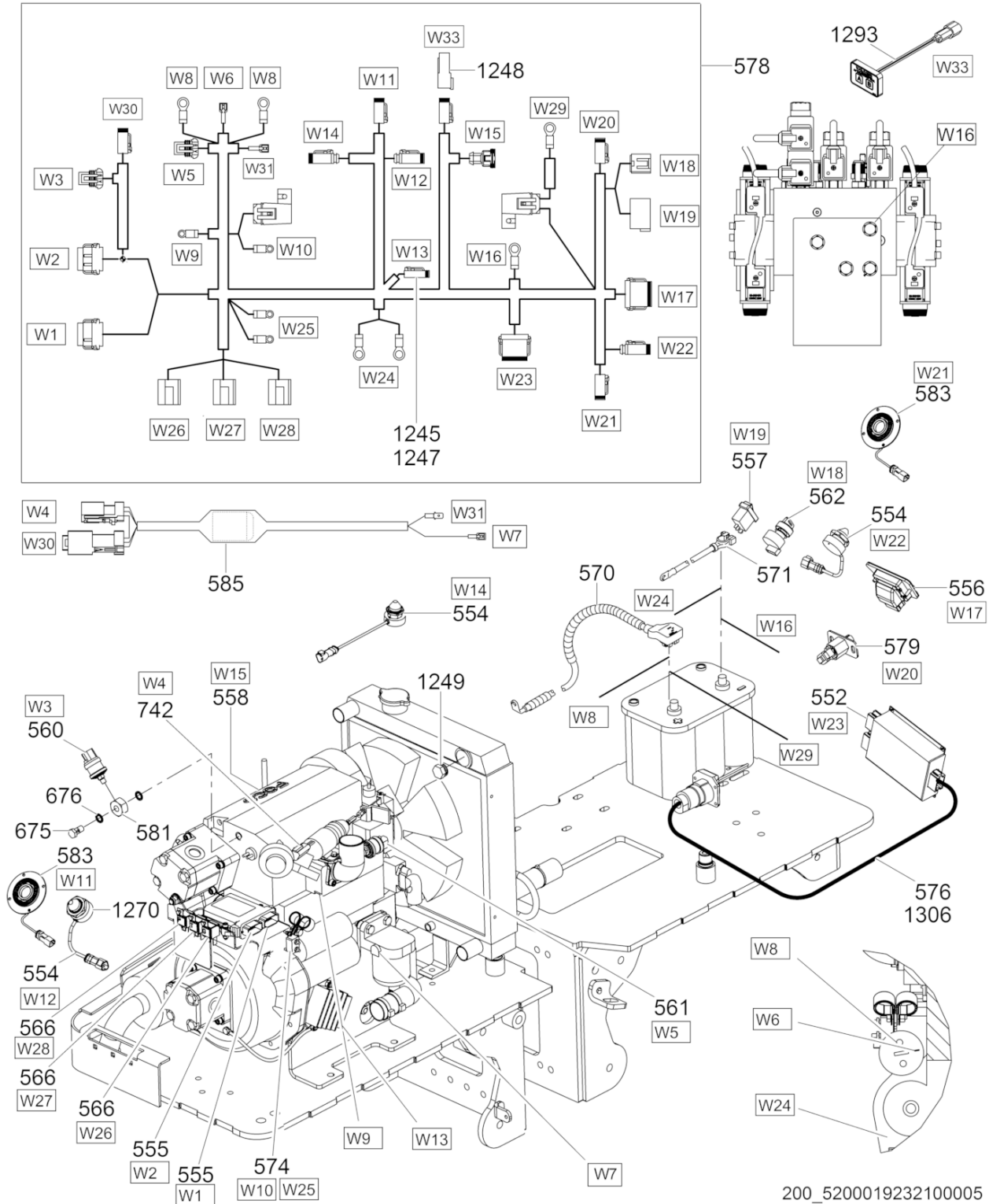

200_520001923210005

Ref. Pos.	Part No. Artikel Nr.	Qty. St.	Description Beschreibung	Descripción Description	Measurem./Abm.	Norm
					Torque/Drehm.	Sealant Schmierstoff
1247	5000160842	1	Lock wedge Haltekeil	Cuña de retención Cale de fixation		
1248	5000161278	1	Coolant bypass wiring harness Kabelbaum für Kühlmittelumlauf	Conjunto de cables para desviación del enfriador Harnais de câbles électriques		
1249	5000086983	1	Plug (threaded) Schraubverschluß	Tapón roscado Bouchon		S9
1270	5000162711	1	Hexagon nut Sechskantmutter	Tuerca hexagonal Écrou hexagonal	M32	
1293	5000172989	1	Diagnostic control module Diagnose-Controllermodul	Módulo controlador de diagnóstico Module contrôle de diagnostic		
1306	5000182304	1	Connector Anschlußteil	Conector Connecteur		

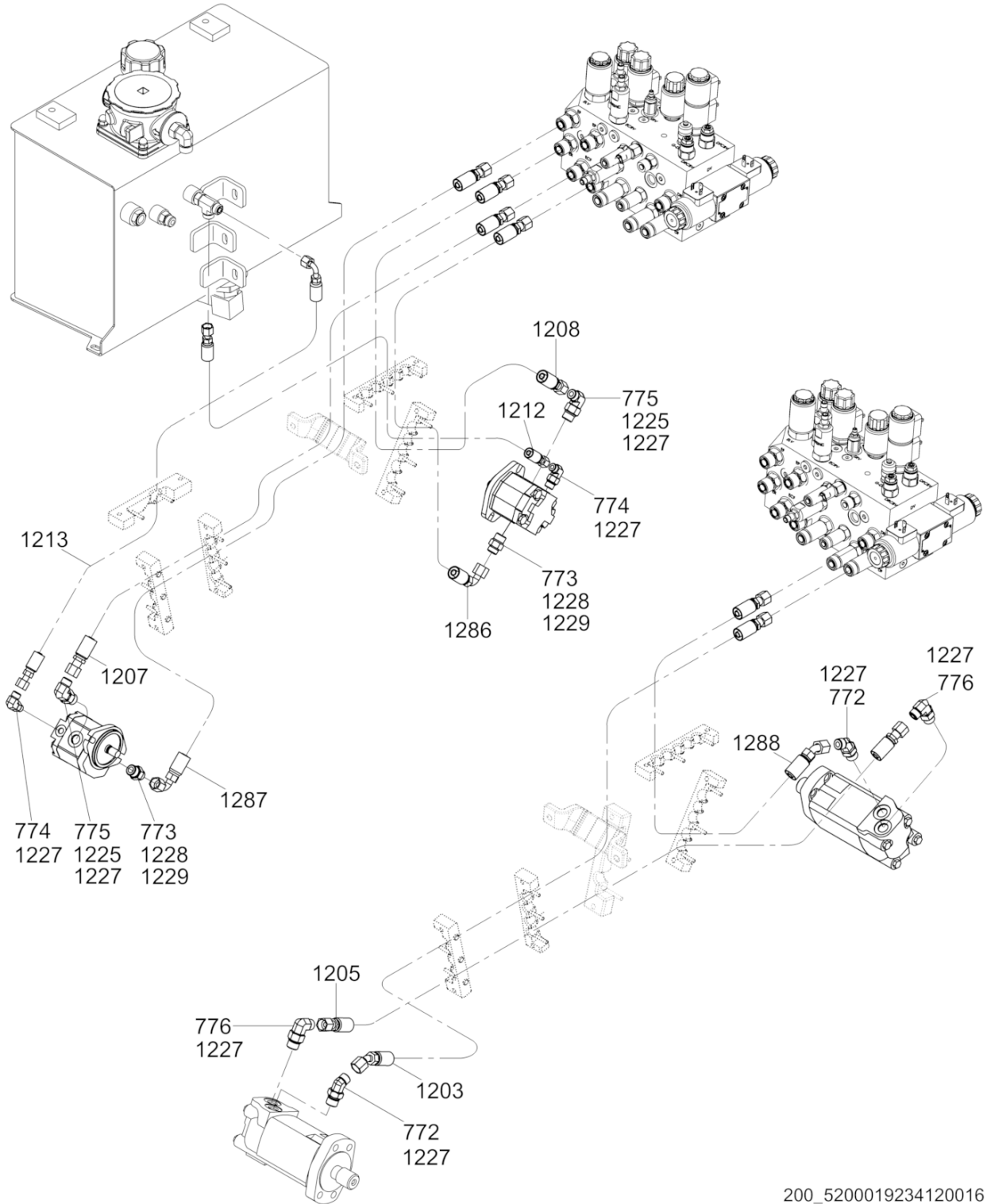

200_5200019234120016

Ref. Pos.	Part No. Artikel Nr.	Qty. St.	Description Beschreibung	Descripción Description	Measurem./Abm.	Norm
					Torque/Drehm.	Sealant Schmierstoff
772	5000151767	4	Hydraulic elbow fitting Hydraulikrohrkrümmer	Codo hidráulico Coude hydraulique	45	S8
773	5000079875	2	Hydraulic fitting Hydraulikverschraubung	Unión hidráulico Raccord hydraulique	No.8 x 10	
774	5000151768	2	Hydraulic elbow fitting Hydraulikrohrkrümmer	Codo hidráulico Coude hydraulique	90	
775	5000081340	2	Elbow fitting Rohrkrümmer	Codo Coude	No.8 x 10 x 90	S8
776	5000081340	2	Elbow fitting Rohrkrümmer	Codo Coude	No.8 x 10 x 90	
1203	5200010939	1	Hydraulic hose Hydraulikschlauch	Manguera hidráulica Tuyau hydraulique	1360	S8
1205	5200010940	1	Hydraulic hose Hydraulikschlauch	Manguera hidráulica Tuyau hydraulique	1275 38Nm/28ft.lbs	S8
1207	5200006474	1	Hydraulic hose Hydraulikschlauch	Manguera hidráulica Tuyau hydraulique	1470 60Nm/44ft.lbs	S8
1208	5200006478	1	Hydraulic hose Hydraulikschlauch	Manguera hidráulica Tuyau hydraulique	995 54Nm/40ft.lbs	S8
1212	5000182222	1	Hydraulic hose Hydraulikschlauch	Manguera hidráulica Tuyau hydraulique	985mm 41Nm/30ft.lbs	S8
1213	5000182221	1	Hydraulic hose Hydraulikschlauch	Manguera hidráulica Tuyau hydraulique	1525mm 41Nm/30ft.lbs	S8
1225	5000080731	5	O-Ring O-Ring	Anillo-O Joint torique	0,468 x 0,078in	
1227	5000080737	16	O-Ring O-Ring	Anillo-O Joint torique	0,489 x 0,070in	
1228	5000080732	8	O-Ring O-Ring	Anillo-O Joint torique	0,644 x 0,087in	
1229	5000080733	2	O-Ring O-Ring	Anillo-O Joint torique	0,755 x 0,097in	
1275	5000170004	1	Protective Hose Kit Schutzschlauchsatz	Juego de Manguera Jue de Tuyau		
1286	5200006554	1	Hydraulic hose Hydraulikschlauch	Manguera hidráulica Tuyau hydraulique	60Nm/44ft.lbs	S8
1287	5200006476	1	Hydraulic hose Hydraulikschlauch	Manguera hidráulica Tuyau hydraulique	1510	
1288	5100014108	1	Hydraulic hose Hydraulikschlauch	Manguera hidráulica Tuyau hydraulique	1060mm	

Ref. Pos.	Part No. Artikel Nr.	Qty. St.	Description Beschreibung	Descripción Description	Measurem./Abm.	Norm
					Torque/Drehm.	Sealant Schmierstoff
455	5000078816	3	Adapter fitting Zwischenverschraubung	Unión con adaptador Raccord intermédiaire	41Nm/30ft.lbs	S8
456	5000158572	2	Fitting Verschraubung	Unión Raccord	No.8	
462	5000156401	1	Fitting Verschraubung	Unión Raccord	90	S9
464	5000156204	1	Fitting Verschraubung	Unión Raccord	No.8-3/8 NPT	S9
470	5000111716	1	Cap Kappe	Tapa Capuchon	No.8	
651	5000119929	2	Fitting cap Verschraubung, Kappe	Unión, tapa Raccord, Capuchon	No.8	S8
653	5000150051	2	Hose clamp Schlauchselle	Abrazaderas de manguera Agrafe de tuyau	No.16	
665	5000119960	2	Fitting Verschraubung	Unión Raccord	No.8	S8
667	5000119962	1	Fitting Verschraubung	Unión Raccord	No.8	S8
712	5000028314	4	Clamp Selle	Abrazadera Agrafe	0,81 x 1,25in	
730	5000088342	2	Fitting Verschraubung	Unión Raccord	90	S8
773	5000079875	2	Hydraulic fitting Hydraulikverschraubung	Unión hidráulico Raccord hydraulique	No.8 x 10	
1200	5000119663	1	Hydraulic hose Hydraulikschlauch	Manguera hidráulica Tuyau hydraulique	1135	
1201	5000119664	1	Hydraulic hose Hydraulikschlauch	Manguera hidráulica Tuyau hydraulique	115	
1202	5000119665	1	Hydraulic hose Hydraulikschlauch	Manguera hidráulica Tuyau hydraulique	570	
1209	5000182643	1	Hydraulic hose Hydraulikschlauch	Manguera hidráulica Tuyau hydraulique	1665mm 60Nm/44ft.lbs	
1210	5000182644	1	Hydraulic hose Hydraulikschlauch	Manguera hidráulica Tuyau hydraulique	1880mm 60Nm/44ft.lbs	
1215	5000182223	1	Hydraulic hose Hydraulikschlauch	Manguera hidráulica Tuyau hydraulique	285mm 41Nm/30ft.lbs	S8
1216	5000182636	1	Hydraulic hose Hydraulikschlauch	Manguera hidráulica Tuyau hydraulique	450mm	S8
1217	5000182224	1	Hydraulic hose Hydraulikschlauch	Manguera hidráulica Tuyau hydraulique	425mm 41Nm/30ft.lbs	S8
1218	5000164955	2	Hydraulic hose Hydraulikschlauch	Manguera hidráulica Tuyau hydraulique		
1220	5000182225	1	Hydraulic hose Hydraulikschlauch	Manguera hidráulica Tuyau hydraulique	590mm 41Nm/30ft.lbs	S8
1224	5000119934	1	Drain hose Abflussschlauch	Manguera de salida Tuyau d'écoulement	570	S8
1225	5000080731	5	O-Ring O-Ring	Anillo-O Joint torique	0,468 x 0,078in	
1226	5000080736	3	O-Ring O-Ring	Anillo-O Joint torique	0,364 x 0,070in	

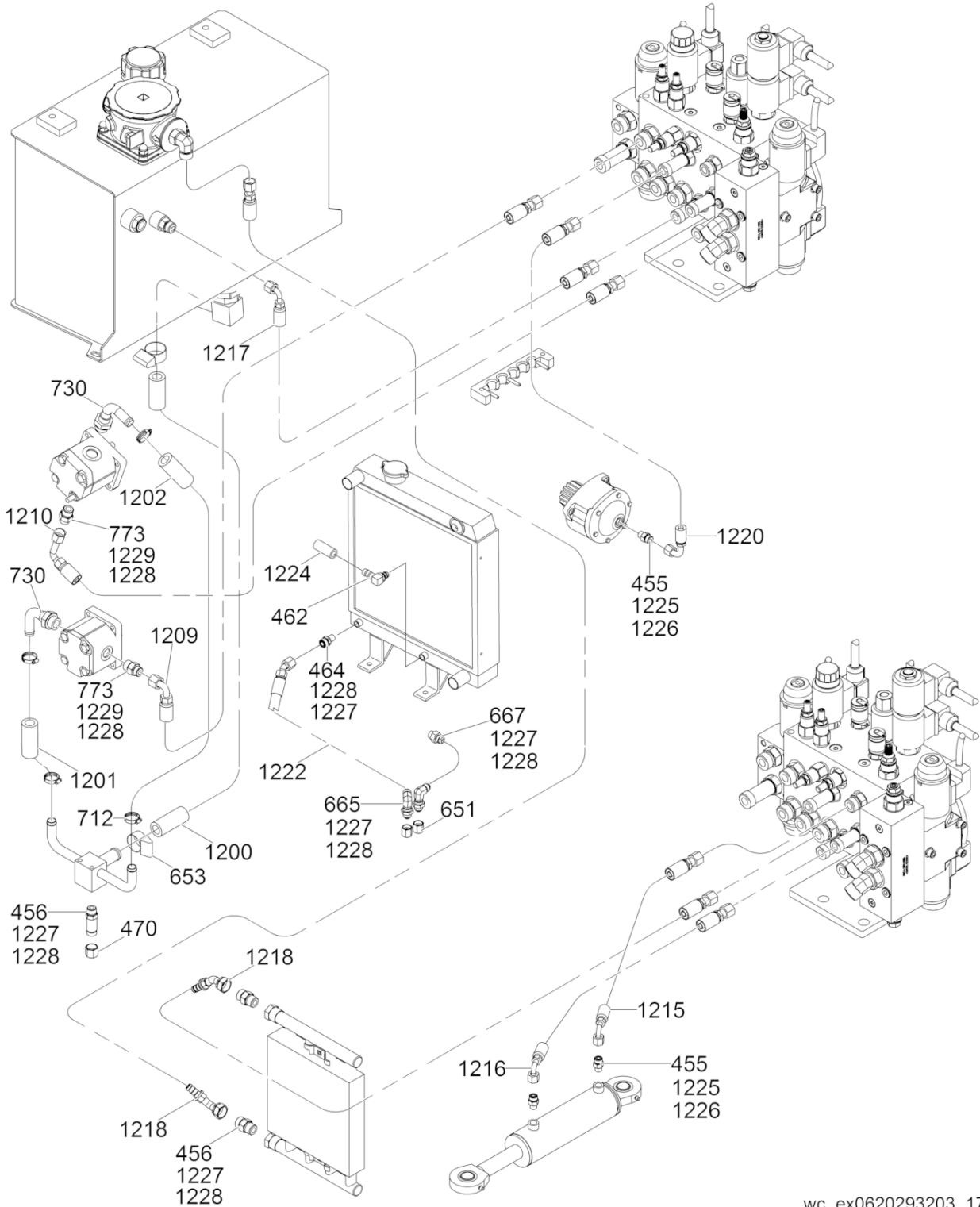

wc_ex0620293203_17

Ref. Pos.	Part No. Artikel Nr.	Qty. St.	Description Beschreibung	Descripción Description	Measurement./Abm.	Norm
					Torque/Drehm.	Sealant Schmierstoff
1227	5000080737	16	O-Ring O-Ring	Anillo-O Joint torique	0,489 x 0,070in	
1228	5000080732	8	O-Ring O-Ring	Anillo-O Joint torique	0,644 x 0,087in	
1229	5000080733	2	O-Ring O-Ring	Anillo-O Joint torique	0,755 x 0,097in	
1275	5000170004	1	Protective Hose Kit Schutzschlauchsatz	Juego de Manguera Jue de Tuyau		

Front Cover
Vorderdeckel
Tapa delantera
Couvercle avant

RTLx-SC3

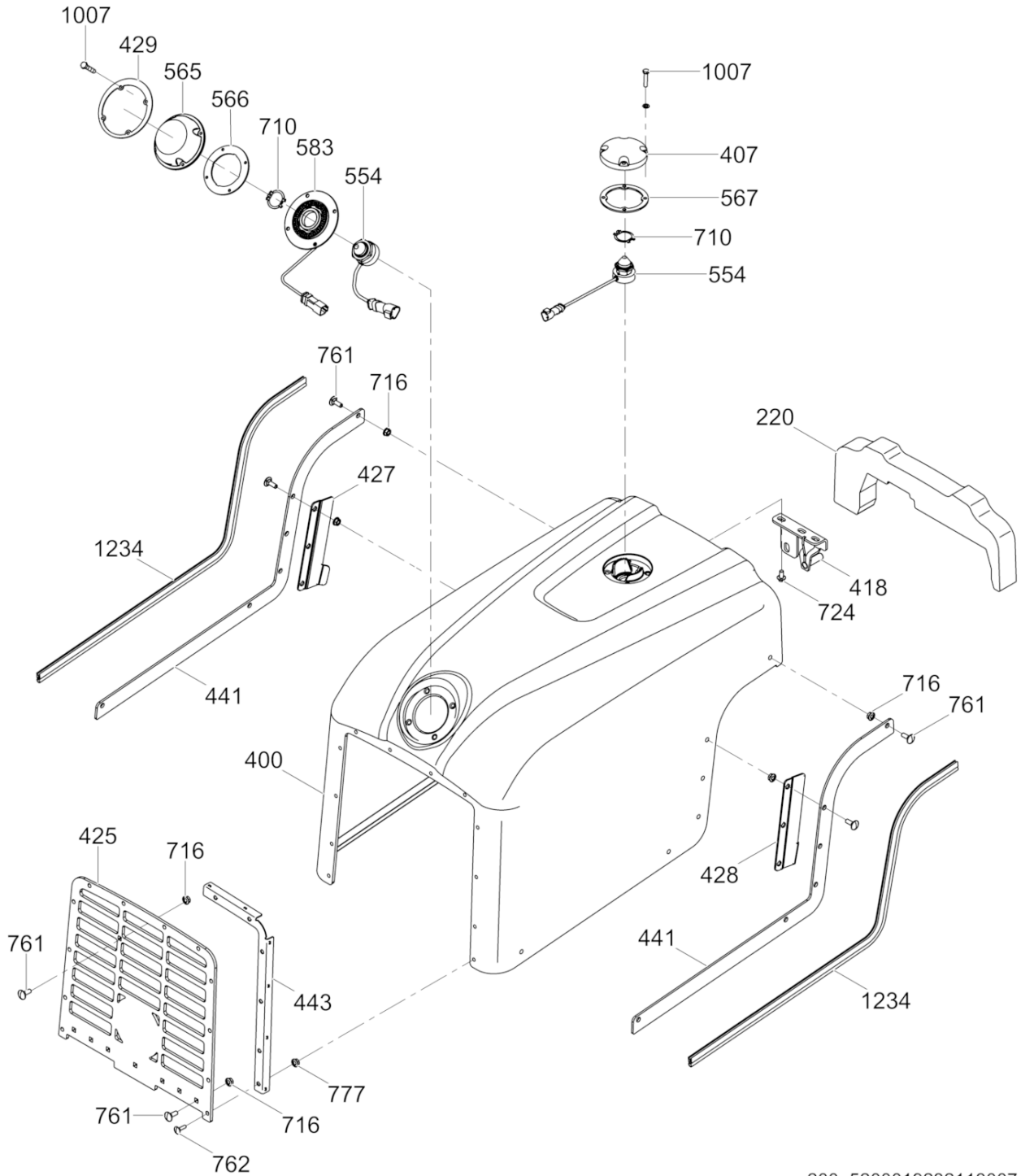

200_5200019232113007

Ref. Pos.	Part No. Artikel Nr.	Qty. St.	Description Beschreibung	Descripción Description	Measurem./Abm.	Norm
					Torque/Drehm.	Sealant Schmierstoff
220	5200019759	1	Trim seal Profilgummi	Moldura Garniture		
220	5000150227	1	Seal Dichtung	Empaque Joint		
400	5200017704	1	Front cover Vorderdeckel	Tapa delantera Couvercle avant		
407	5200018182	1	Cap Kappe	Tapa Capuchon		
418	5200019751	1	Bracket Konsole	Soporte Support		
425	5200019770	1	Grille cover Gitter	Rejilla Grille		
427	5200019757	1	Bracket Konsole	Soporte Support		
428	5200019758	1	Bracket Konsole	Soporte Support		
429	5200019775	1	Ring Ring	Anillo Anneau		
441	5200019755	2	Bracket Konsole	Soporte Support		
443	5200019774	1	Bracket Konsole	Soporte Support		
554	5000170949	2	Infrared sensor Empfängerauge	Receptor de rayos Oeil récepteur		
565	5200011851	1	Cap Kappe	Tapa Capuchon		
566	5100026695	1	Gasket Dichtung	Junta Joint		
567	5100026696	1	Gasket Dichtung	Junta Joint		
583	5000154403	1	Light ring module Lichtringmodul	Módulo de anillo de luz Module de l'anneau lumineux		
710	5000172857	2	Retaining washer Scheibe	Arandela Rondelle		
716	5000030066	20	Locknut Sechskantmutter	Contratuerca Contre-écrou	M8	
724	5000155839	3	Hexagonal head cap screw Sechskantschraube	Tornillo hexagonal Boulon à tête hexagonale	M8 x 16	
761	5000163950	20	Carriage bolt Schloßschraube	Tornillo de carruaje Boulon brut à tête bombée	M8 x 25	
762	5000164579	12	Carriage bolt Schloßschraube	Tornillo de carruaje Boulon brut à tête bombée	M6 x 25	
777	5000029117	12	Lock nut Sicherungsmutter	Contratuerca Contre-écrou	M6	
1007	5000011474	8	Hexagonal head cap screw Sechskantschraube	Tornillo hexagonal Vis à tête hexagonale	M5 x 25 6Nm/4ft.lbs	DIN933 S3
1234	5000159561	2	Seal-trim Profilgummi	Moldura Garniture	1000	

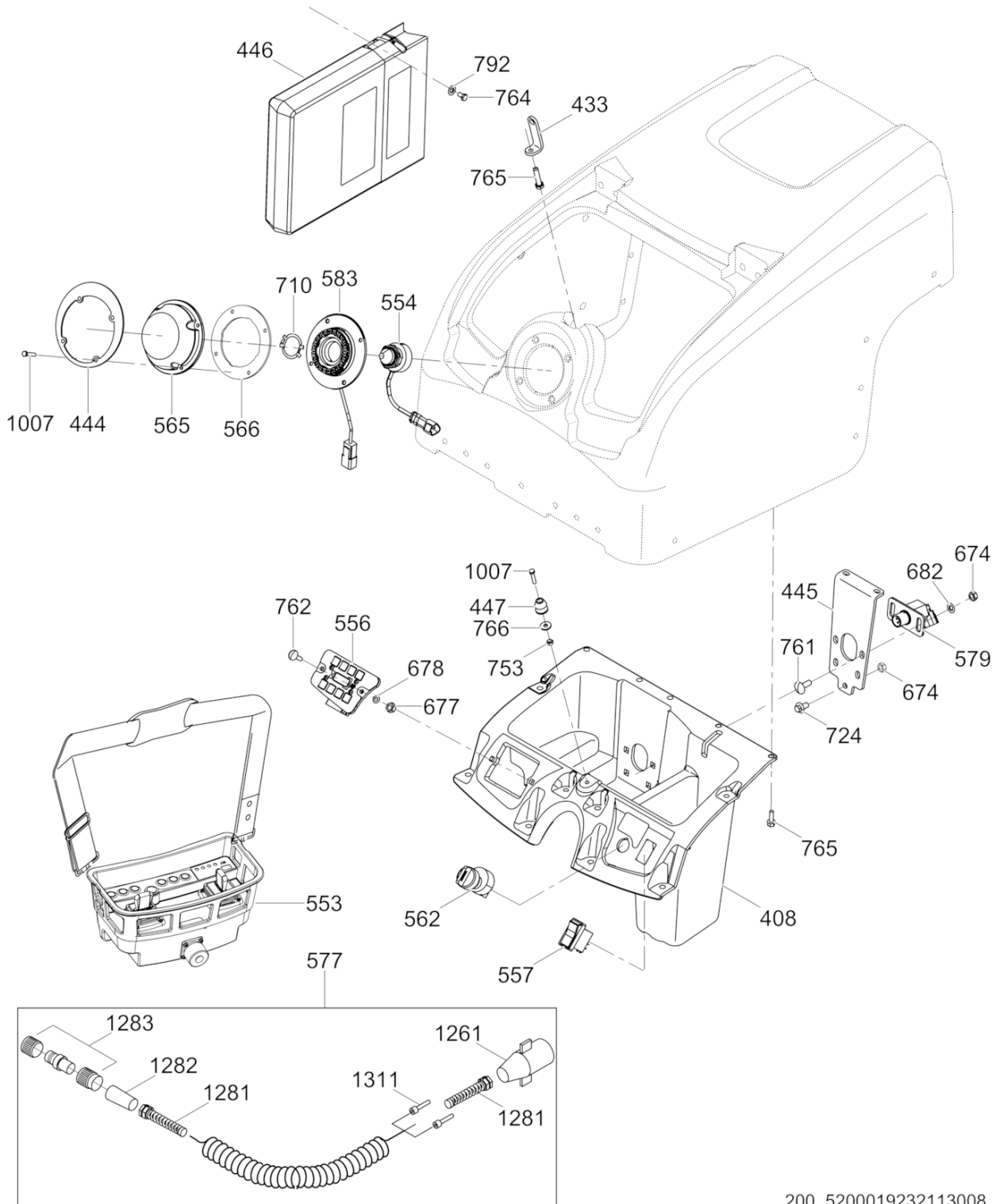

200_5200019232113008

Ref. Pos.	Part No. Artikel Nr.	Qty. St.	Description Beschreibung	Descripción Description	Measurem./Abm.	Norm
					Torque/Drehm.	Sealant Schmierstoff
408	5200018183	1	Console Bedienungskonsole	Pupitre de mando Panneau de contrôle		
433	5200019786	1	Tab Zunge	Orejeta Onglet		
444	5200019779	1	Mount Konsole	Ménsula Support		
445	5200019784	1	Bracket Konsole	Soporte Support		
446	5000153425	1	Manual holder Handbuchhalter	Soporte manual Support de manuel		
447	5000170979	1	Door latch Türverriegelung	Aldaba de puerta Loquet de porte		
553	5000165514	1	Transmitter module Sender	Transmisor Transmetteur		
554	5000170949	2	Infrared sensor Empfängerauge	Receptor de rayos Oeil récepteur		
556	5000178862	1	Display module Anzeigemodul	Módulo de visualización Module d'affichage		
557	5000150110	1	Switch Schalter	Interruptor Interrupteur		
562	5000150115	1	Ignition switch Zündschalter	Interruptor de encendido Interrupteur d'ignition		
565	5200011851	1	Cap Kappe	Tapa Capuchon		
566	5100026695	1	Gasket Dichtung	Junta Joint		
577	5000154417	1	Charging cable Ladungskabel	Cable de carga Câble de charge		
579	5000178854	1	Charge port module Ladungsanschlussmodul	Módulo de toma de carga Module de prise de charge		
583	5000154403	1	Light ring module Lichtringmodul	Módulo de anillo de luz Module de l'anneau lumineux		
674	5000010367	4	Hexagon nut Sechskantmutter	Tuerca hexagonal Écrou hexagonal	M8	DIN985
677	5000010368	2	Hexagon nut Sechskantmutter	Tuerca hexagonal Écrou hexagonal	M6	DIN985
678	5000010624	2	Flat washer Scheibe	Arandela Rondelle		
682	5000010622	2	Flat washer Scheibe	Arandela Rondelle		
710	5000172857	1	Retaining washer Scheibe	Arandela Rondelle		
724	5000155839	3	Hexagonal head cap screw Sechskantschraube	Tornillo hexagonal Boulon à tête hexagonale	M8 x 16	
753	5000010369	1	Hexagon nut Sechskantmutter	Tuerca hexagonal Écrou hexagonal		
761	5000163950	4	Carriage bolt Schloßschraube	Tornillo de carruaje Boulon brut à tête bombée	M8 x 25	
762	5000164579	2	Carriage bolt Schloßschraube	Tornillo de carruaje Boulon brut à tête bombée	M6 x 25	

Ref. Pos.	Part No. Artikel Nr.	Qty. St.	Description Beschreibung	Descripción Description	Measurement./Abm.	Norm
					Torque/Drehm.	Sealant Schmierstoff
764	5000012356	4	Hexagonal head cap screw Sechskantschraube	Tornillo hexagonal Vis à tête hexagonale	M6 x 10 10Nm/7ft.lbs	DIN933
765	5200020974	13	Hexagonal flange head screw Sechskantflanschschaube	Tornillo hexagonal de brida Vis hexagonale de bride	M6 x 20 10Nm/7ft.lbs	
766	5000010372	1	Flat washer Scheibe	Arandela Rondelle	B5,3	DIN9021
792	5000010373	4	Flat washer Scheibe	Arandela Rondelle	6	ISO7093
1007	5000011474	5	Hexagonal head cap screw Sechskantschraube	Tornillo hexagonal Vis à tête hexagonale	M5 x 25 6Nm/4ft.lbs	DIN933 S3
1261	5000164490	1	Plug connector (9 pin) 9-Stift Anschlussstecker	Enchufe de (9 agujas) Fiche à (9 broches)		
1281	5000089676	2	Strain relief Zugentlastung	Alivio de esfuerzos Effort à la décharge		
1282	5000088821	1	Adaptor Adapter	Adaptador Adaptateur		
1283	5000116889	1	Plug cpl. Stopfen kpl.	Tapón compl Bouchon compl		
1311	5100037420	2	Pin terminal Stiftklemme	Terminal de pasador Épingle terminal		

Rear Cover
Hinterdeckel
Tapa de atrás
Couvercle arrière

RTLx-SC3

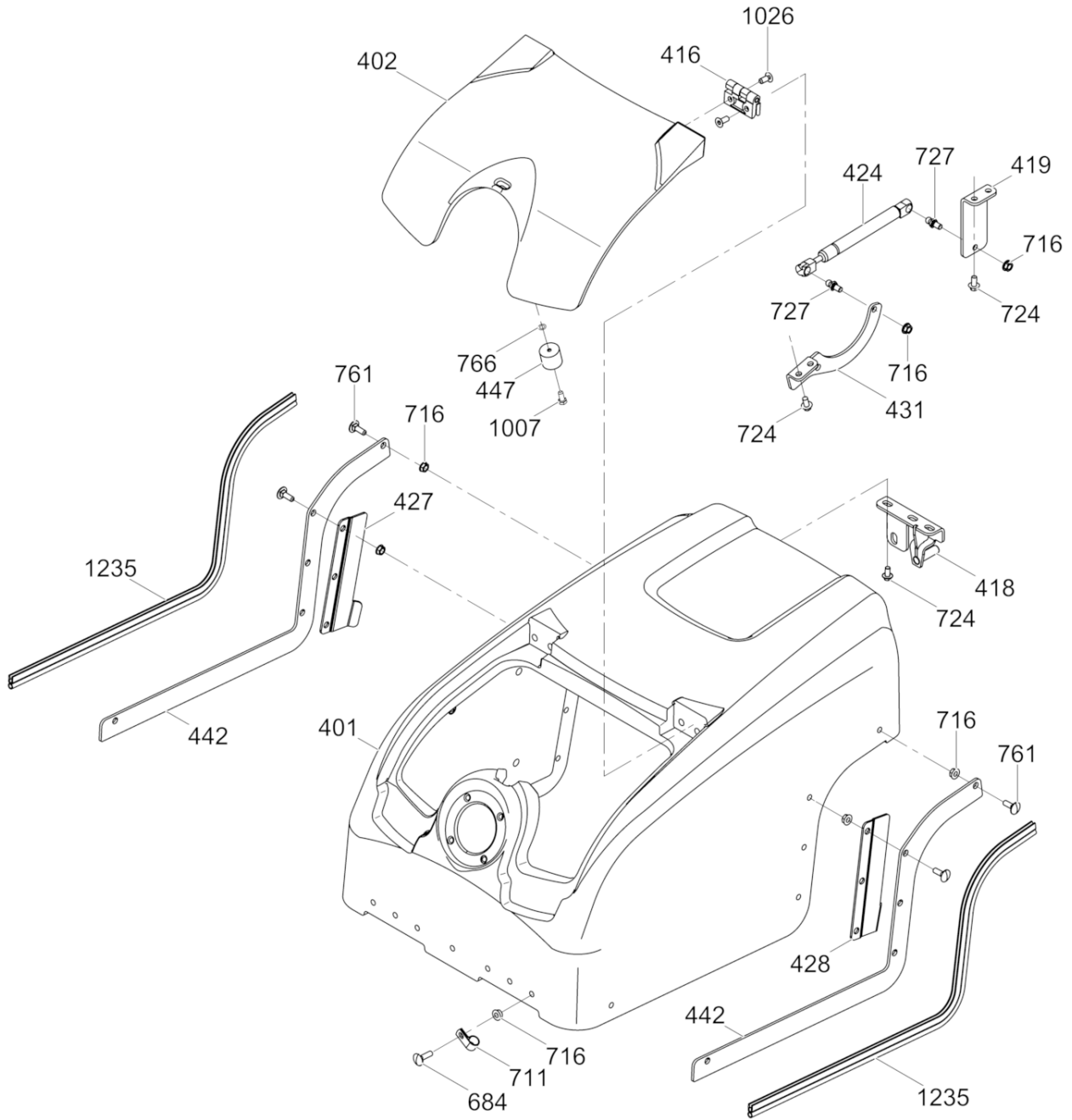

200_5200019232100009

Ref. Pos.	Part No. Artikel Nr.	Qty. St.	Description Beschreibung	Descripción Description	Measurement./Abm.	Norm
					Torque/Drehm.	Sealant Schmierstoff
401	5200017705	1	Rear cover Hinterdeckel	Tapa de atrás Couvercle arrière		
402	5200017707	1	Access cover Abdeckplatte	Tapa de acceso Couvercle à accès		
416	5000154400	2	Hinge Scharnier	Bisagra Charnière		
418	5200019751	1	Bracket Konsole	Soporte Support		
419	5200019783	1	Bracket Konsole	Soporte Support		
424	5000154401	1	Cylinder Zylinder	Cilindro Cylindre		
427	5200019757	1	Bracket Konsole	Soporte Support		
428	5200019758	1	Bracket Konsole	Soporte Support		
431	5200019785	1	Lifting bracket Hebebügel	Ménsula alzadora Support de relèvement		
442	5200019756	2	Bracket Konsole	Soporte Support		
447	5000170979	1	Door latch Türverriegelung	Aldaba de puerta Loquet de porte		
684	5000011151	7	Carriage bolt Schloßschraube	Tornillo de carruaje Boulon brut à tête bombée	M8 x 30	DIN603
711	5000163957	1	Tube clamp Rohrschelle	Abrazadera para mangueras Agrafe pour tuyaux souples	5/16in ID	
711	5000163956	1	Clamp Schelle	Abrazadera Agrafe		
716	5000030066	19	Locknut Sechskantmutter	Contratuercas Contre-écrou	M8	
724	5000155839	7	Hexagonal head cap screw Sechskantschraube	Tornillo hexagonal Boulon à tête hexagonale	M8 x 16	
727	5000155125	1	Stud Gewindebolzen	Perno prisionero Goujon	M8 x 10	
761	5000163950	10	Carriage bolt Schloßschraube	Tornillo de carruaje Boulon brut à tête bombée	M8 x 25	
766	5000010372	1	Flat washer Scheibe	Arandela Rondelle	B5,3	DIN9021
1007	5000011474	1	Hexagonal head cap screw Sechskantschraube	Tornillo hexagonal Vis à tête hexagonale	M5 x 25 6Nm/4ft.lbs	DIN933
1026	5000021563	8	Countersunk screw Senkschraube	Tornillo avellanado Vis noyée	M8 x 20 25Nm/18ft.lbs	ISO10642
1235	5000159562	2	Seal-trim Profilgummi	Moldura Garniture	822	

**Drum Drive
Bandagenantrieb**

RTLx-SC3

**Accionamiento de Tambor
Entraînement de Tambour**

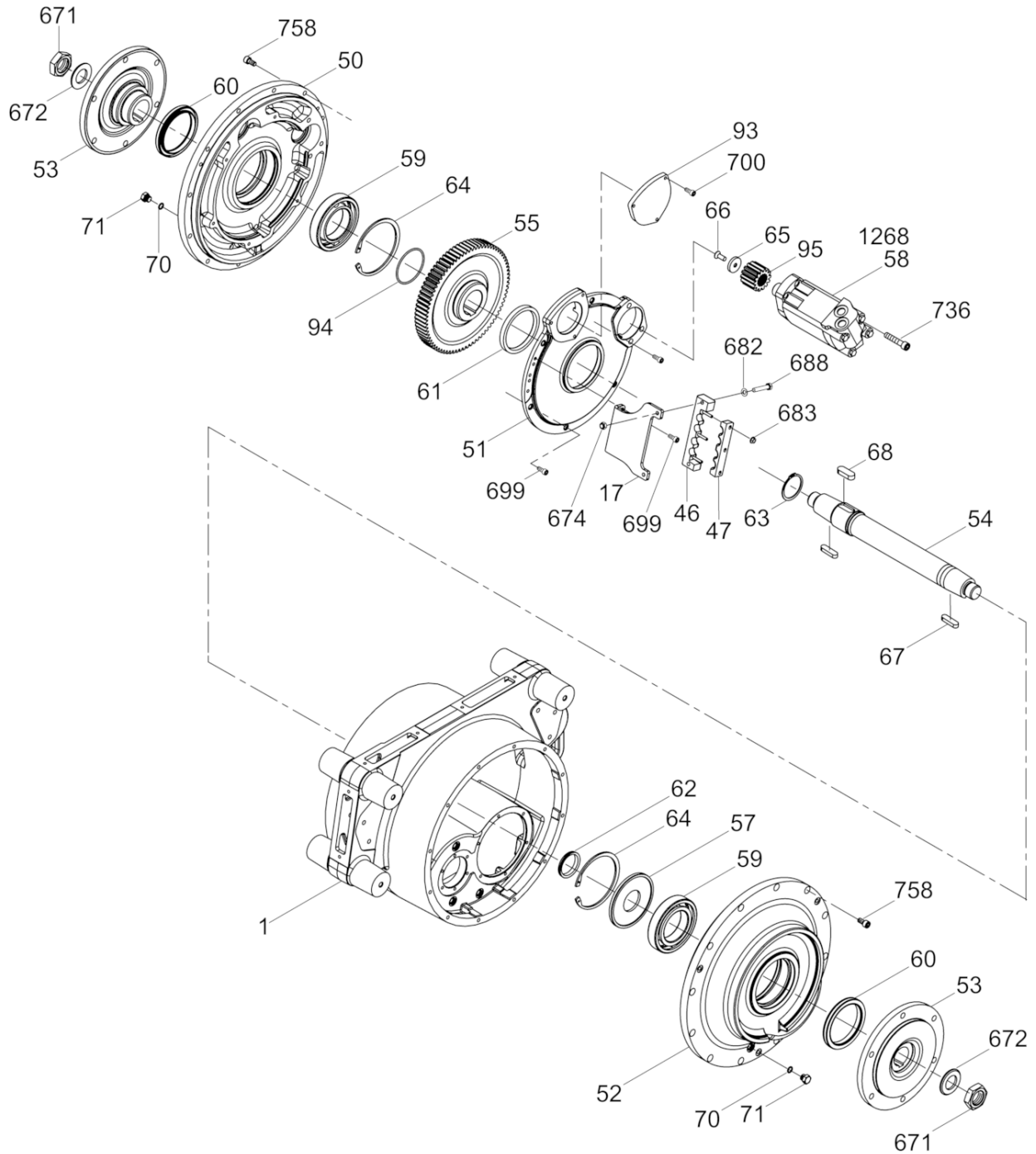

200_5000620293232010

Ref. Pos.	Part No. Artikel Nr.	Qty. St.	Description Beschreibung	Descripción Description	Measurem./Abm.	Norm
					Torque/Drehm.	Sealant Schmierstoff
1	5000116902	1	Drum support Bandagenträger	Soporte del tambor Support de tambour		
17	5200007278	1	Bracket Konsole	Soporte Support		
46	5000150252	1	Hose clamp Schlauchschele	Abrazaderas de manguera Agrafe de tuyau		
47	5000150253	1	Hose clamp Schlauchschele	Abrazaderas de manguera Agrafe de tuyau		
50	5000118366	1	Cover Deckel	Tapa Couvercle		
51	5000118368	1	Cover Deckel	Tapa Couvercle		
52	5000116903	1	Cover Deckel	Tapa Couvercle		
53	5000116906	2	Drum hub Bandagennabe	Maza de tambor Moyeu de tambour		
54	5000116907	1	Drive shaft Antriebswelle	Eje motor Arbre d'entraînement		
55	5000119284	1	Gear Zahnrad	Engranaje Engrenage		
57	5000118796	1	Disc Scheibe	Disco Disque		
58	5000181899	1	Drive motor Antriebsmotor	Motor de accionamiento Moteur d'entraînement		
59	5000082961	2	Roller bearing Rollenlager	Rodamiento de rodillos Roulement à rouleaux		
60	5000119285	2	Seal Dichtung	Empaque Joint		
61	5000116874	1	Shaft seal Wellendichtring	Sello del eje Bague d'étanchéité	100 x 120 x 12	
62	5000119286	1	Shaft seal Wellendichtring	Sello del eje Bague d'étanchéité		
63	5000116869	1	Retaining ring Sicherungsring	Anillo de retención Bague d'arrêt	62 x 2	DIN471
64	5000044706	2	Retaining ring Sicherungsring	Anillo de retención Bague d'arrêt	140 x 4	DIN472
65	5000080666	1	Washer Scheibe	Arandela Rondelle		
66	5000080667	1	Screw Schraube	Tornillo Vis	3/8-16 x 1in	S3
67	5000116872	2	Square key Passfeder	Chaveta Clavette	A14 x 9 x 50	DIN6885
68	5000116873	1	Square key Passfeder	Chaveta Clavette	A18 x 11 x 50	DIN6885
70	5000014398	2	O-Ring O-Ring	Anillo-O Joint torique	12 x 2	
71	5000078269	2	Plug (threaded) Schraubverschluß	Tapón roscado Bouchon	9/16-18in	
93	5000119505	1	Plate Platte	Placa Plaque		

**Drum Drive
Bandagenantrieb**

RTLx-SC3

**Accionamiento de Tambor
Entraînement de Tambour**

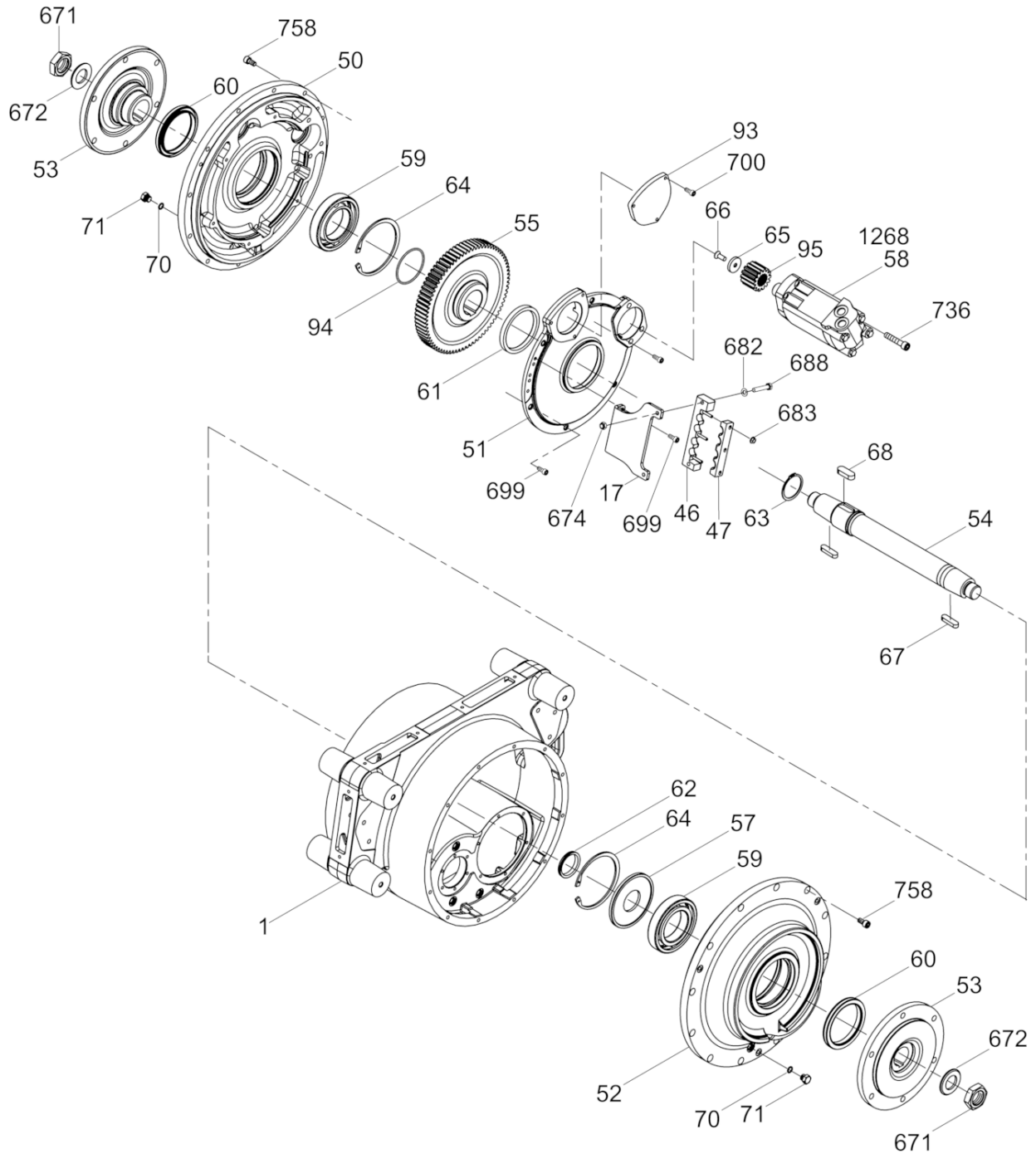

200_5000620293232010

Ref. Pos.	Part No. Artikel Nr.	Qty. St.	Description Beschreibung	Descripción Description	Measurement./Abm.	Norm
					Torque/Drehm.	Sealant Schmierstoff
94	5000152276	1	O-Ring O-Ring	Anillo-O Joint torique	81,92 x 5,33	
95	5000154482	1	Pinion gear Ritzel	Piñon diferencial Pignon		
671	5000116871	2	Nut Mutter	Tuerca Écrou	M36 x 3 825Nm/609ft.lbs	S3
672	5000150020	2	Washer Scheibe	Arandela Rondelle	M36	
674	5000010367	2	Hexagon nut Sechskantmutter	Tuerca hexagonal Écrou hexagonal	M8	DIN985
682	5000010622	2	Flat washer Scheibe	Arandela Rondelle		
683	5000155519	3	Flange nut Flanschmutter	Tuerca de reborde Ecrou de bride	M6	DIN 1661
688	5000117969	2	Hexagonal head cap screw Sechskantschraube	Tornillo hexagonal Boulon à tête hexagonale	M8 x 45 25Nm/18ft.lbs	
699	5000011543	8	Socket head screw Zylinderschraube	Tornillo hueco Vis à six-pans creux	M8 x 20 25Nm/18ft.lbs	ISO4762
700	5000011544	3	Cheese head screw Zylinderschraube	Tornillo cilíndrico Vis à tête cylindrique	M8 x 16 41Nm/30ft.lbs	ISO4762 S3
736	5000111979	3	Socket head cap screw Zylinderschraube	Tornillo cilíndrico Vis à tête cylindrique	M12 x 60 85Nm/63ft.lbs	ISO4762 S4
758	5000072758	30	Cheese head screw Zylinderschraube	Tornillo cilíndrico Vis à tête cylindrique	M10 x 20 49Nm/36ft.lbs	ISO4762 S3
1268	5000182756	1	Seal Kit Dichtungssatz	Juego-empaque Jeu-joint		

Drum Drive w/Brake
Bandagenantrieb mit Bremse
Accionamiento de Tambor con Freno
Entraînement de Tambour avec F

RTLx-SC3

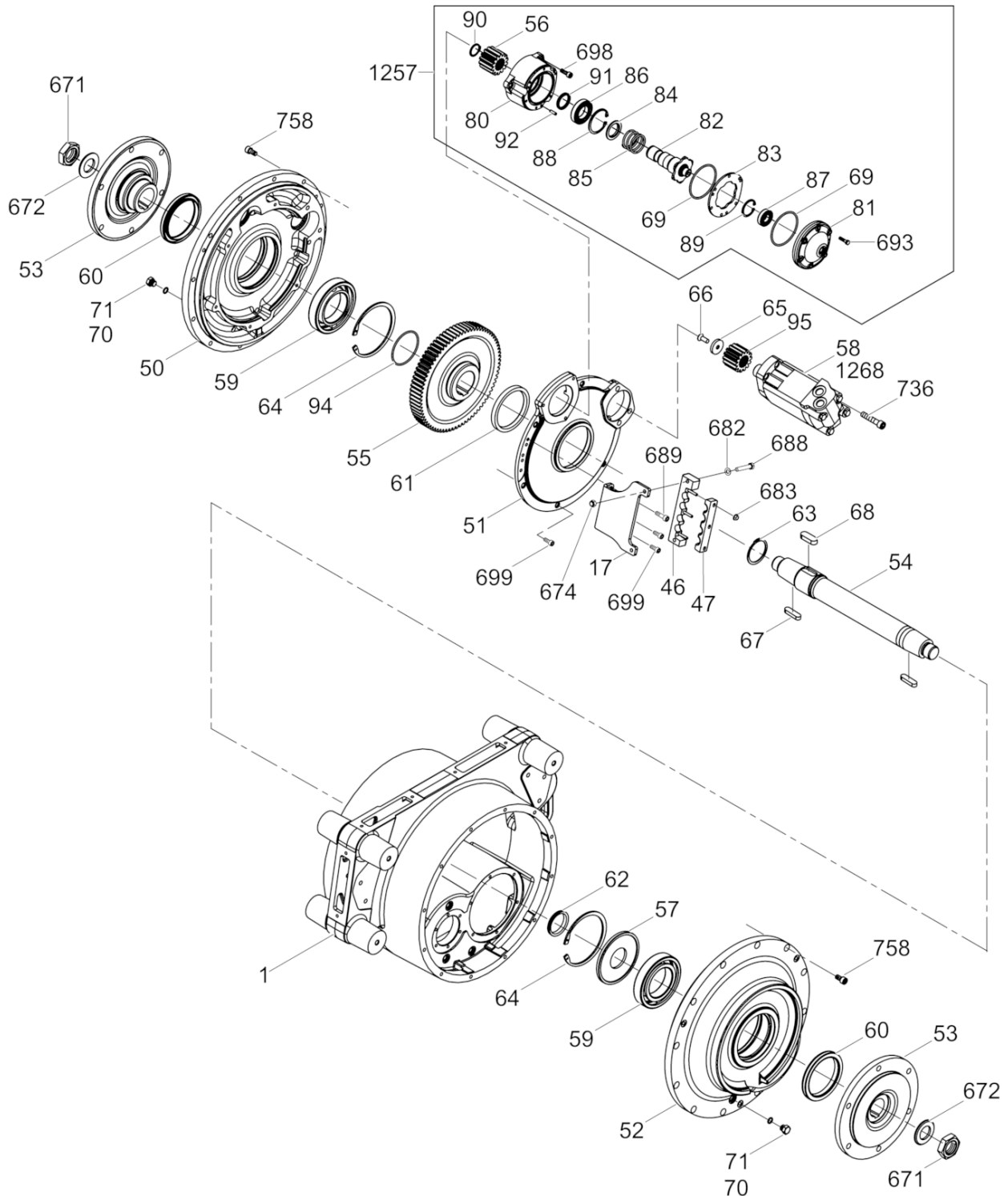

200_5000620293232011

Ref. Pos.	Part No. Artikel Nr.	Qty. St.	Description Beschreibung	Descripción Description	Measurem./Abm.	Norm
					Torque/Drehm.	Sealant Schmierstoff
1	5000116902	1	Drum support Bandagenträger	Soporte del tambor Support de tambour		
17	5200007278	1	Bracket Konsole	Soporte Support		
40	5200008651	1	Clamp Schelle	Abrazadera Agrafe		
41	5200008650	1	Clamp Schelle	Abrazadera Agrafe		
50	5000118366	1	Cover Deckel	Tapa Couvercle		
51	5000118368	1	Cover Deckel	Tapa Couvercle		
52	5000116903	1	Cover Deckel	Tapa Couvercle		
53	5000116906	2	Drum hub Bandagennabe	Maza de tambor Moyeu de tambour		
54	5000116907	1	Drive shaft Antriebswelle	Eje motor Arbre d'entraînement		
55	5000119284	1	Gear Zahnrad	Engranaje Engrenage		
56	5000116909	1	Pinion gear Ritzel	Piñon diferencial Pignon		
57	5000118796	1	Disc Scheibe	Disco Disque		
58	5000181899	1	Drive motor Antriebsmotor	Motor de accionamiento Moteur d'entraînement		
59	5000082961	2	Roller bearing Rollenlager	Rodamiento de rodillos Roulement à rouleaux		
60	5000119285	2	Seal Dichtung	Empaque Joint		
61	5000116874	1	Shaft seal Wellendichtring	Sello del eje Bague d'étanchéité	100 x 120 x 12	
62	5000119286	1	Shaft seal Wellendichtring	Sello del eje Bague d'étanchéité		
63	5000116869	1	Retaining ring Sicherungsring	Anillo de retención Bague d'arrêt	62 x 2	DIN471
64	5000044706	2	Retaining ring Sicherungsring	Anillo de retención Bague d'arrêt	140 x 4	DIN472
65	5000080666	1	Washer Scheibe	Arandela Rondelle		
66	5000080667	1	Screw Schraube	Tornillo Vis	3/8-16 x 1in	
67	5000116872	2	Square key Passfeder	Chaveta Clavette	A14 x 9 x 50	DIN6885
68	5000116873	1	Square key Passfeder	Chaveta Clavette	A18 x 11 x 50	DIN6885
69	5000119329	3	O-Ring O-Ring	Anillo-O Joint torique	85,32 x 3,53	
70	5000014398	2	O-Ring O-Ring	Anillo-O Joint torique	12 x 2	

Drum Drive w/Brake
Bandagenantrieb mit Bremse
Accionamiento de Tambor con Freno
Entraînement de Tambour avec F

RTLx-SC3

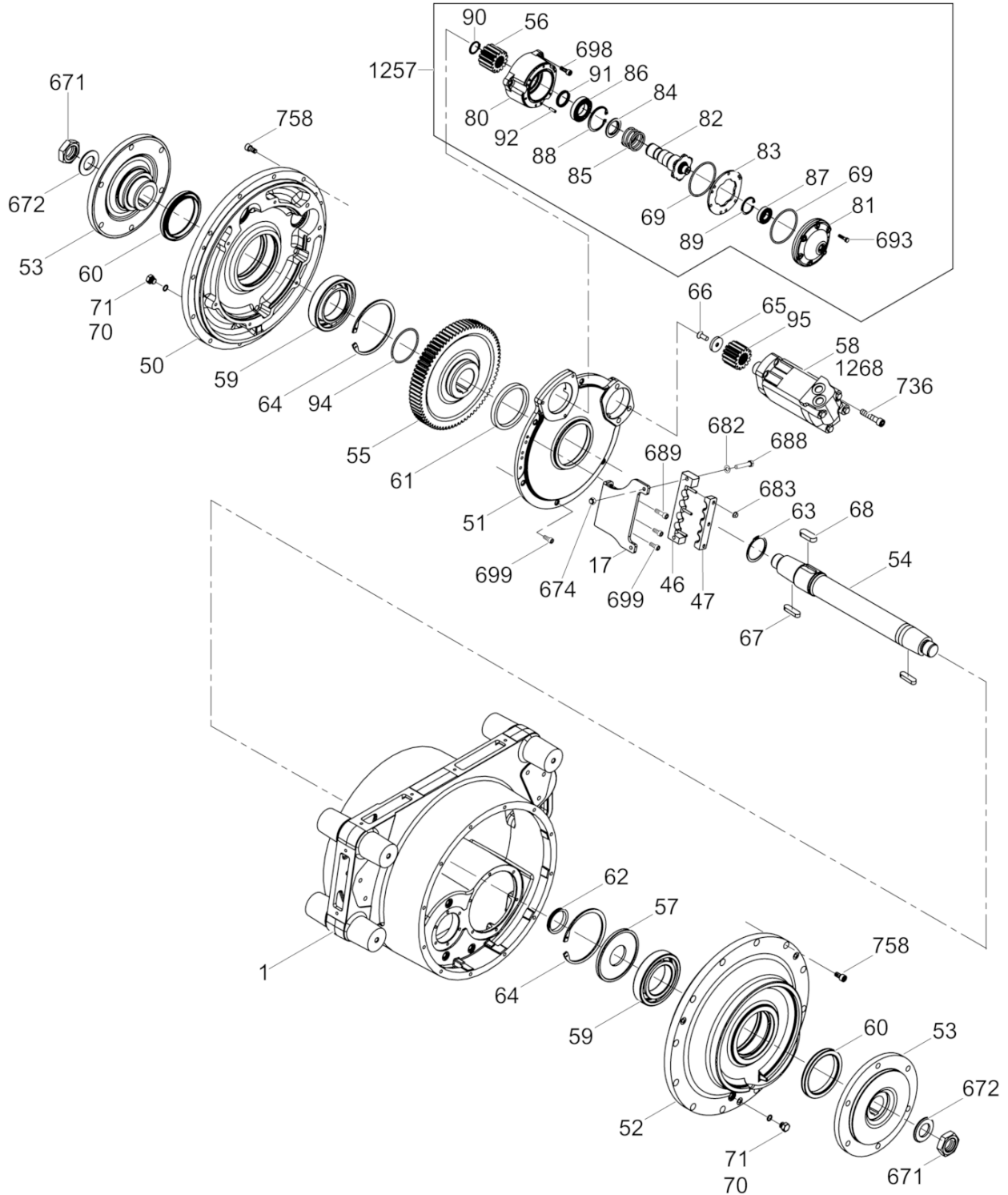

200_5000620293232011

Ref. Pos.	Part No. Artikel Nr.	Qty. St.	Description Beschreibung	Descripción Description	Measurem./Abm.	Norm
					Torque/Drehm.	Sealant Schmierstoff
71	5000078269	2	Plug (threaded) Schraubverschluss	Tapón roscado Bouchon	9/16-18in	
80	5000119377	1	Housing Gehäuse	Caja Carter		
81	5000117564	1	Cover Deckel	Tapa Couvercle		
82	5000154320	1	Shaft Welle	Eje Arbre		
83	5000117612	1	Plate Platte	Placa Plaque		
84	5000151152	1	Ring Ring	Anillo Anneau		
85	5000085783	1	Spring Feder	Resorte Ressort		
86	5000027402	1	Grooved ball bearing Rillenkugellager	Rodamiento de bolas Roulement à billes		
87	5002006236	1	Grooved ball bearing Rillenkugellager	Rodamiento de bolas Roulement à billes		
88	5002001042	1	Retaining ring Sicherungsring	Anillo de retención Bague d'arrêt	62 x 2	DIN472
89	5002004639	1	Retaining ring Sicherungsring	Anillo de retención Bague d'arrêt	42 x 1,75	DIN472
90	5000152277	1	Retaining ring Sicherungsring	Anillo de retención Bague d'arrêt	1,25 x 0,05	
91	5000089840	1	Shaft seal Wellendichtring	Sello del eje Bague d'étanchéité		
92	5000054245	3	Roll pin Spannstift	Pasador Goupille de tension	7/32 x 3/4 in	
93	5000119505	1	Plate Platte	Placa Plaque		
94	5000152276	1	O-Ring O-Ring	Anillo-O Joint torique	81,92 x 5,33	
95	5000154482	1	Pinion gear Ritzel	Piñon diferencial Pignon		
671	5000116871	2	Nut Mutter	Tuerca Écrou	M36 x 3 825Nm/609ft.lbs	S3
672	5000150020	2	Washer Scheibe	Arandela Rondelle	M36	
674	5000010367	2	Hexagon nut Sechskantmutter	Tuerca hexagonal Écrou hexagonal	M8	DIN985
682	5000010622	2	Flat washer Scheibe	Arandela Rondelle		
683	5000153379	3	Gasket Dichtung	Junta Joint		
688	5000117969	2	Hexagonal head cap screw Sechskantschraube	Tornillo hexagonal Boulon à tête hexagonale	M8 x 45 25Nm/18ft.lbs	
689	5000011541	1	Cheese head screw Zylinderschraube	Tornillo cilíndrico Vis à tête cylindrique		
693	5000011469	6	Hexagonal head cap screw Sechskantschraube	Tornillo hexagonal Vis à tête hexagonale	M6 x 25 10Nm/7ft.lbs	DIN933 S4

Drum Drive w/Brake
Bandagenantrieb mit Bremse
Accionamiento de Tambor con Freno
Entraînement de Tambour avec F

RTLx-SC3

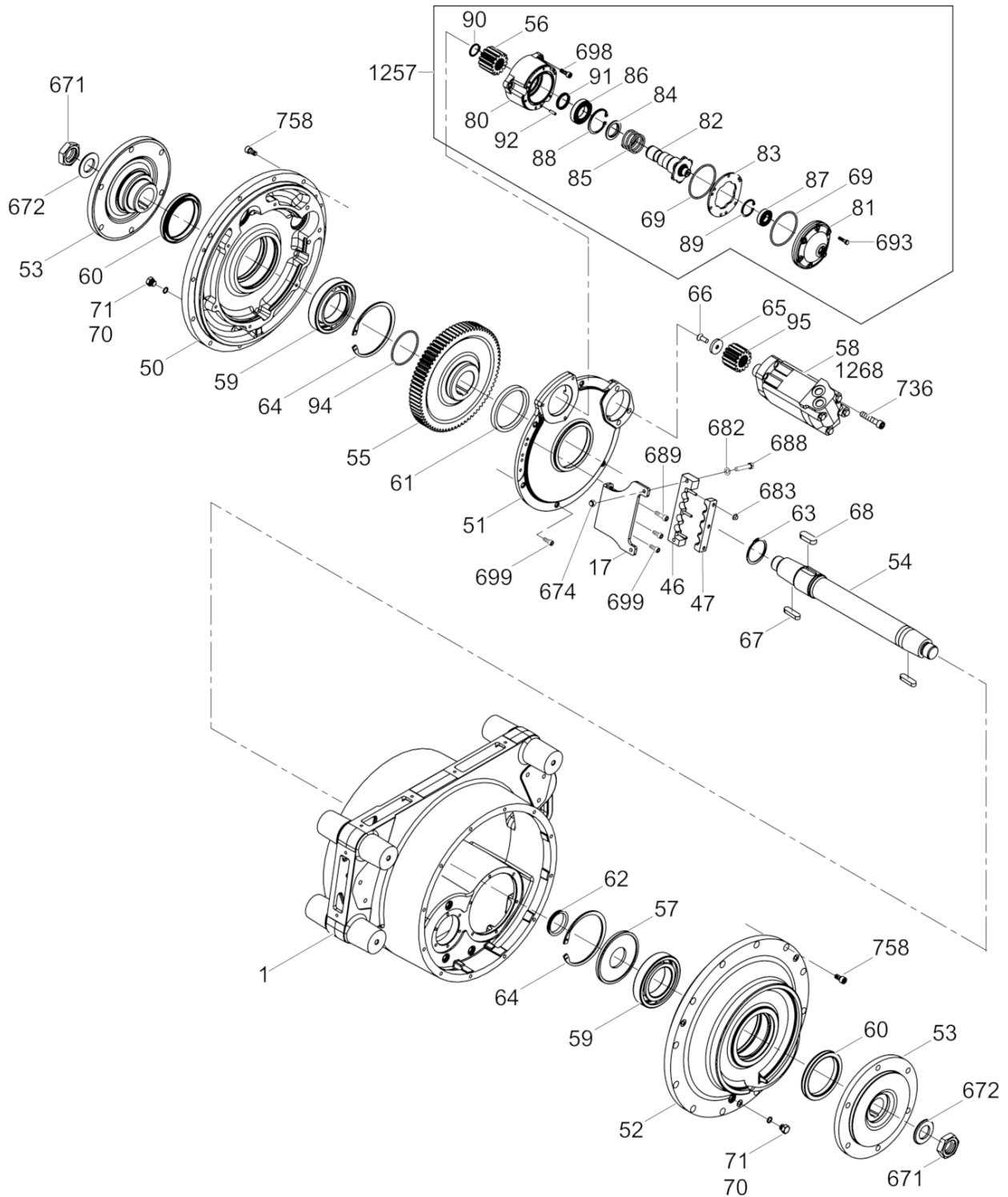

200_5000620293232011

Ref. Pos.	Part No. Artikel Nr.	Qty. St.	Description Beschreibung	Descripción Description	Measurement./Abm.	Norm
					Torque/Drehm.	Sealant Schmierstoff
698	5000011542	3	Cheese head screw Zylinderschraube	Tornillo cilíndrico Vis à tête cylindrique	41Nm/30ft.lbs	S3
699	5000011543	6	Socket head screw Zylinderschraube	Tornillo hueco Vis à six-pans creux	M8 x 20 25Nm/18ft.lbs	ISO4762
736	5000111979	3	Socket head cap screw Zylinderschraube	Tornillo cilíndrico Vis à tête cylindrique	M12 x 60 85Nm/63ft.lbs	ISO4762 S4
758	5000072758	30	Cheese head screw Zylinderschraube	Tornillo cilíndrico Vis à tête cylindrique	M10 x 20 49Nm/36ft.lbs	ISO4762 S3
1257	5000163621	1	Brake cpl. Bremse kpl.	Freno compl. Frein compl.		
1268	5000182756	1	Seal Kit Dichtungssatz	Juego-empaque Jeu-joint		

**Front Drum
Vorderbandage
Tambor Delantero
Tambour Avant**

RTLx-SC3

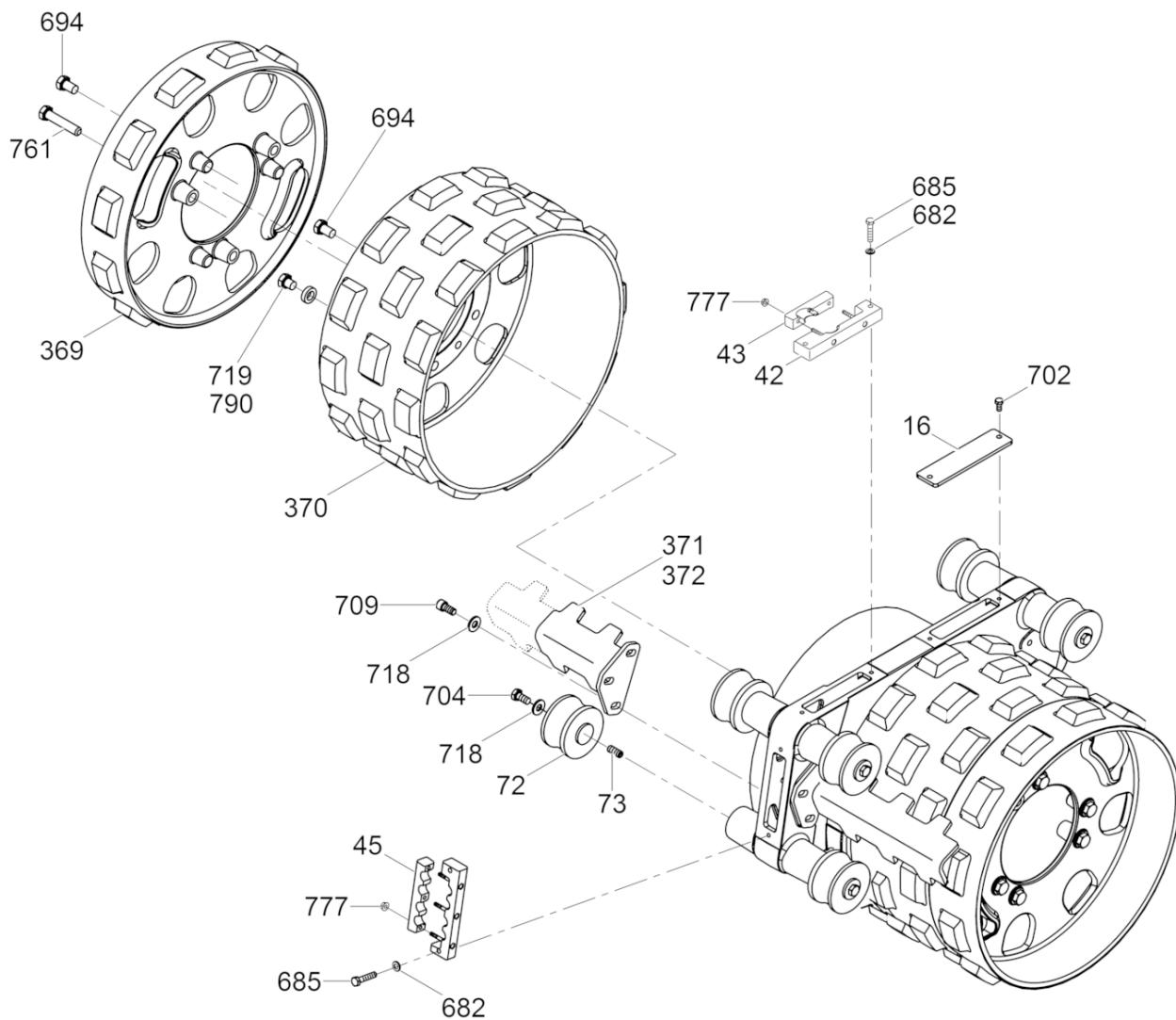

200_5200008538100012

Ref. Pos.	Part No. Artikel Nr.	Qty. St.	Description Beschreibung	Descripción Description	Measurement./Abm.	Norm
					Torque/Drehm.	Sealant Schmierstoff
16	5000150306	1	Plate Platte	Placa Plaque		
42	5000181900	1	Hose clamp Schlauchschele	Abrazaderas de manguera Agrafe de tuyau		
43	5000181901	1	Hose clamp Schlauchschele	Abrazaderas de manguera Agrafe de tuyau		
44	5000150252	1	Hose clamp Schlauchschele	Abrazaderas de manguera Agrafe de tuyau		
45	5000150253	1	Hose clamp Schlauchschele	Abrazaderas de manguera Agrafe de tuyau		
72	5002004814	6	Shockmount Gimmetall-Kerblager mit Bund	Amortiguador Silentbloc	100 x 58	
73	5000180963	6	Setscrew Gewindestift	Tornillo Vis	M12 x 35	
369	5200003694	4	Drum extension Bandageverlängerung	Tambor de Extensión Extension de Tambour		
370	5200009074	2	Narrow drum Bandage-schmal	Tambor-angosto Tambour étroit		
371	5200007070	4	Wide Scraper Bar Kit Abstreifersatz (breit)	Juego de barra raspadora (anch) barre de curette (large)		
372	5200007073	4	Narrow Scraper Bar Kit Abstreifersatz (schmal)	Juego de barra raspadora (angosto) Jeu de barre de curette (étroi)		
682	5000010622	4	Flat washer Scheibe	Arandela Rondelle		
685	5000011341	4	Hexagonal head cap screw Sechskantschraube	Tornillo hexagonal Vis à tête hexagonale	M8 x 40 25Nm/18ft.lbs	DIN931 S3
694	5000011524	12	Hexagonal head cap screw Sechskantschraube	Tornillo hexagonal Vis à tête hexagonale	M16 x 25 211Nm/156ft.lbs	DIN933 S3
702	5000012361	2	Hexagonal head cap screw Sechskantschraube	Tornillo hexagonal Vis à tête hexagonale	M8 x 16 25Nm/18ft.lbs	DIN933 S3
704	5000013002	6	Hexagonal head cap screw Sechskantschraube	Tornillo hexagonal Vis à tête hexagonale	M12 x 25 86Nm/63ft.lbs	DIN933 S3
709	5000017087	12	Socket head cap screw Zylinderschraube	Tornillo cilíndrico Vis à tête cylindrique	M12 x 30 86Nm/63ft.lbs	ISO4762 S3
718	5000031565	18	Lockwasher Spannscheibe	Arandela elástica Rondelle de ressort	12	DIN6796
719	5000031826	6	Screw Schraube	Tornillo Vis	M16 x 16 210Nm/155ft.lbs	S3
761	5000011380	12	Hexagonal head cap screw Sechskantschraube	Tornillo hexagonal Boulon à tête hexagonale	M16 x 80 210Nm/155ft.lbs	DIN 931
777	5000029117	5	Lock nut Sicherungsmutter	Contratuerca Contre-écrou	M6	
790	5200009076	12	Washer Scheibe	Arandela Rondelle	M16	

Rear Drum
Hinterbandage
Tambor de Atrás
Tambour Arrière

RTLx-SC3

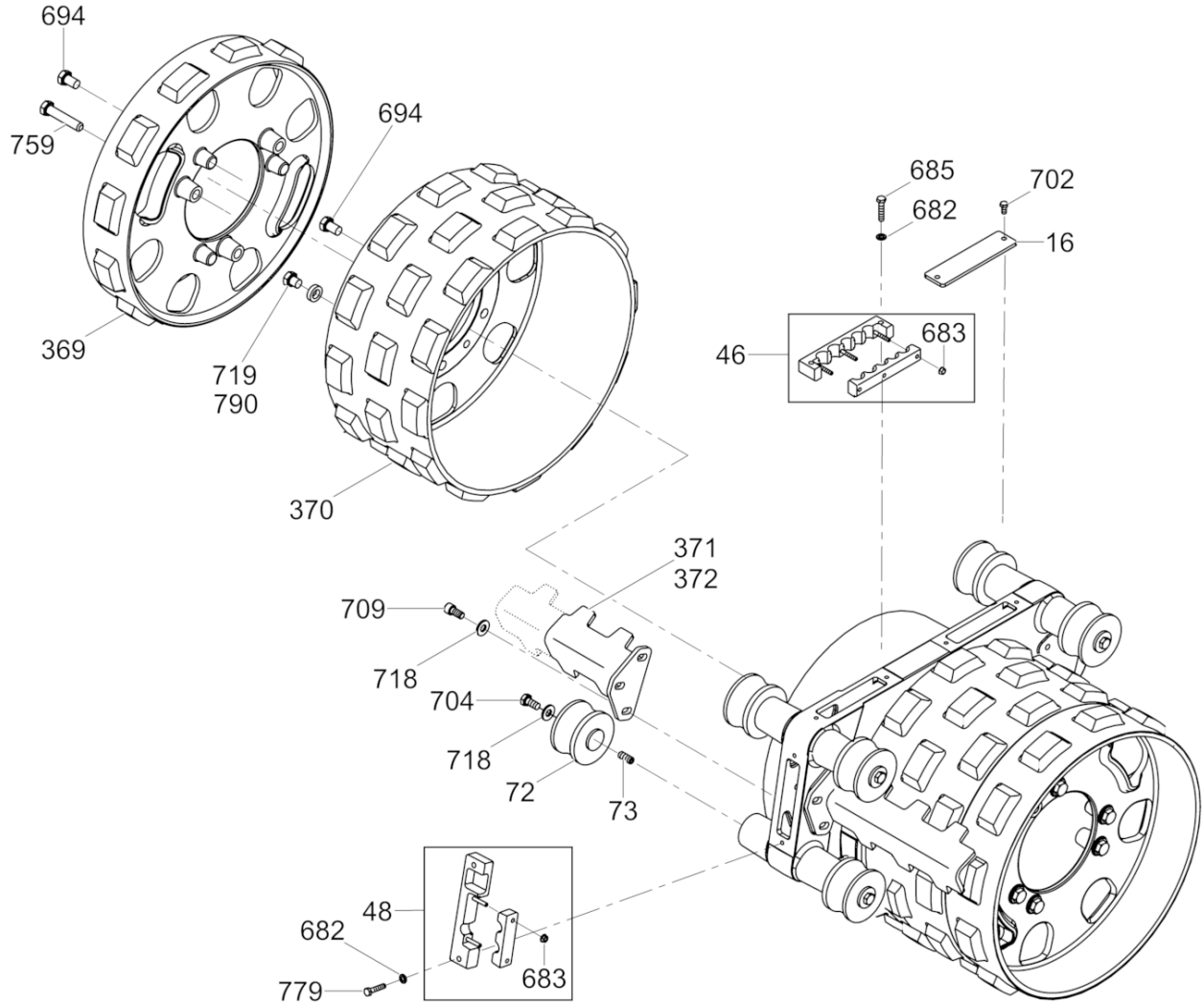

200_5200019257120014

Ref. Pos.	Part No. Artikel Nr.	Qty. St.	Description Beschreibung	Descripción Description	Measurement./Abm.	Norm
					Torque/Drehm.	Sealant Schmierstoff
16	5000150306	1	Plate Platte	Placa Plaque		
46	5200020388	1	Clamp Set Schellensatz	Juego de abrazaderas Jeu-agrafes		
48	5100036426	1	Clamp Set Schellensatz	Juego de abrazaderas Jeu-agrafes		
72	5002004814	6	Shockmount Gimmetall-Kerblager mit Bund	Amortiguador Silentbloc	100 x 58	
73	5000180963	6	Setscrew Gewindestift	Tornillo Vis	M12 x 35	
369	5200003694	2	Drum extension Bandageverlängerung	Tambor de Extensión Extension de Tambour		
370	5200009074	2	Narrow drum Bandage-schmal	Tambor-angosto Tambour étroit		
371	5200007070	4	Wide Scraper Bar Kit Abstreifersatz (breit)	Juego de barra raspadora (anch) barre de curette (large)		
372	5200007073	4	Narrow Scraper Bar Kit Abstreifersatz (schmal)	Juego de barra raspadora (angosto) Jeu de barre de curette (étroi)		
678	5000010624	2	Flat washer Scheibe	Arandela Rondelle		
682	5000010622	5	Flat washer Scheibe	Arandela Rondelle		
685	5000011341	4	Hexagonal head cap screw Sechskantschraube	Tornillo hexagonal Vis à tête hexagonale	M8 x 40 25Nm/18ft.lbs	DIN931 S3
694	5000011524	12	Hexagonal head cap screw Sechskantschraube	Tornillo hexagonal Vis à tête hexagonale	M16 x 25 210Nm/155ft.lbs	DIN933 S3
702	5000012361	2	Hexagonal head cap screw Sechskantschraube	Tornillo hexagonal Vis à tête hexagonale	M8 x 16 25Nm/18ft.lbs	DIN933 S3
704	5000013002	6	Hexagonal head cap screw Sechskantschraube	Tornillo hexagonal Vis à tête hexagonale	M12 x 25 86Nm/63ft.lbs	DIN933 S3
709	5000017087	12	Socket head cap screw Zylinderschraube	Tornillo cilíndrico Vis à tête cylindrique	M12 x 30 86Nm/63ft.lbs	ISO4762 S3
718	5000031565	18	Lockwasher Spannscheibe	Arandela elástica Rondelle de ressort	12	DIN6796
719	5000031826	6	Screw Schraube	Tornillo Vis	M16 x 16 210Nm/155ft.lbs	S3
759	5000011380	6	Hexagonal head cap screw Sechskantschraube	Tornillo hexagonal Boulon à tête hexagonale	M16 x 80 210Nm/155ft.lbs	DIN 931
779	5000011456	2	Hexagonal head cap screw Sechskantschraube	Tornillo hexagonal Vis à tête hexagonale		
790	5200009076	12	Washer Scheibe	Arandela Rondelle	M16	

Exciter cpl.
Erreger kpl.
Excitador compl.
Excitatrice compl.

RTLx-SC3

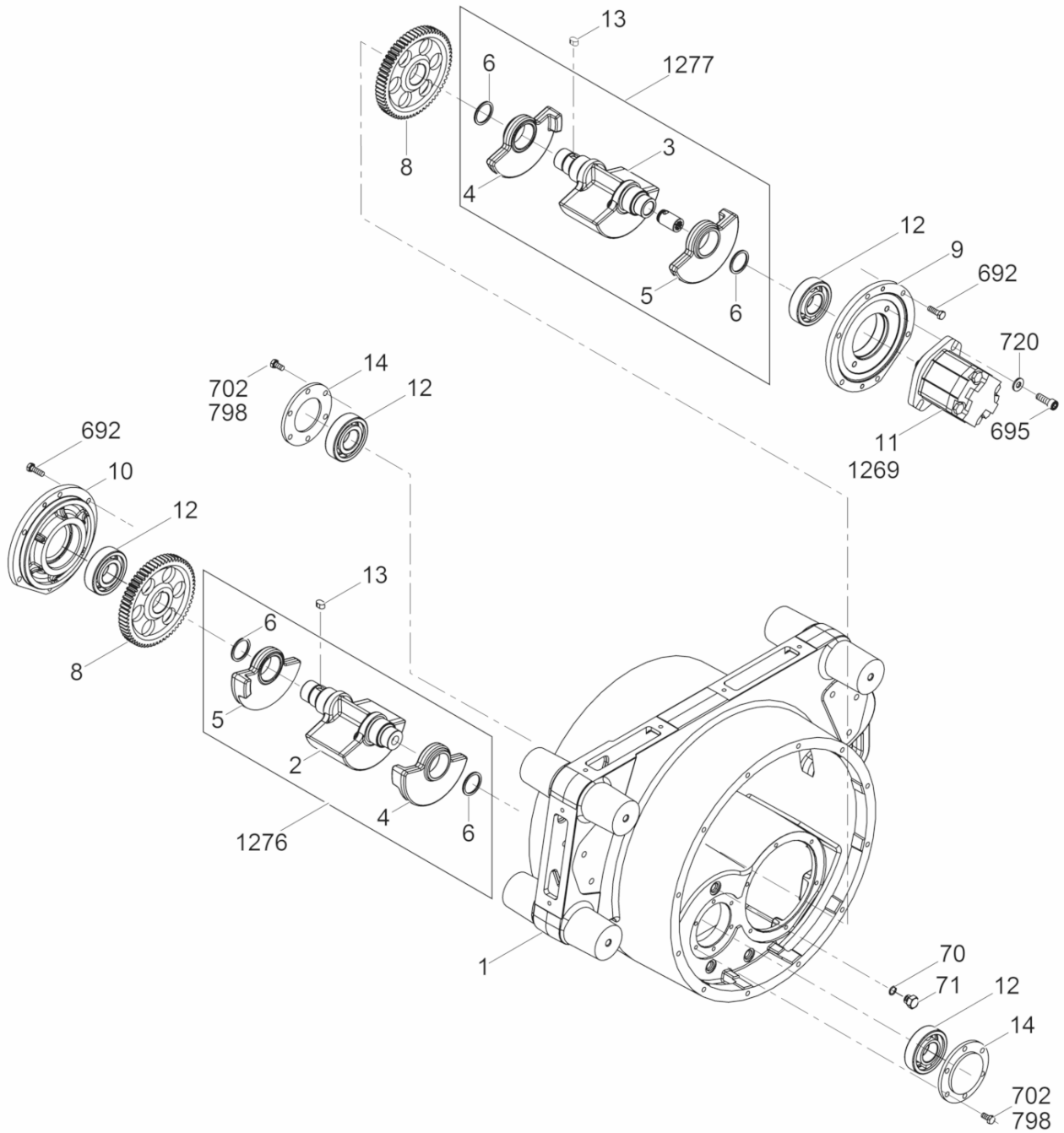

200_5000620293232014

Ref. Pos.	Part No. Artikel Nr.	Qty. St.	Description Beschreibung	Descripción Description	Measurement/Abm.	Norm
					Torque/Drehm.	Sealant Schmierstoff
1	5000116902	1	Drum support Bandagenträger	Soporte del tambor Support de tambour		
2	5000171032	2	Exciter shaft w/o counterbore Erregerwelle ohne Senkung	Eje del excitador s/escariador Arbre de l'excitatrice sans lo		
3	5000171033	2	Exciter shaft w/counterbore Erregerwelle mit Senkung	Eje del excitador c/escariador Arbre de l'excitatrice avec lo		
4	5000171034	4	Eccentric weight Unwucht	Masa excéntrica Balourd excentrique		
5	5000171035	4	Eccentric weight Unwucht	Masa excéntrica Balourd excentrique		
6	5000171028	8	Retaining ring Sicherungsring	Anillo de retención Bague d'arrêt	45 x 1,69in	
8	5200001515	2	Gear Zahnrad	Engranaje Engrenage		
9	5000116958	1	Cover Deckel	Tapa Couvercle		
10	5000116959	1	Bearing cover Lagerdeckel	Tapa del rodamiento Tapa del rodamiento		
11	5000182917	1	Exciter motor Erregermotor	Motor excitador Moteur d'excitatrice		
12	5000080742	4	Roller bearing Rollenlager	Rodamiento de rodillos Roulement à rouleaux		
13	5000115699	2	Square key Passfeder	Chaveta Clavette	A10 x 8 x 16	DIN6885
14	5000171000	4	Cover Deckel	Tapa Couvercle		
70	5000014398	3	O-Ring O-Ring	Anillo-O Joint torique	12 x 2	
71	5000078269	3	Plug (threaded) Schraubverschluß	Tapón roscado Bouchon	9/16-18in	
692	5000011457	12	Hexagonal head cap screw Sechskantschraube	Tornillo hexagonal Vis à tête hexagonale	M8 x 25 25Nm/18ft.lbs	DIN933 S3
695	5000011534	2	Cheese head screw Zylinderschraube	Tornillo cilíndrico Vis à tête cylindrique	M10 x 30 49Nm/36ft.lbs	ISO4762
702	5000012361	12	Hexagonal head cap screw Sechskantschraube	Tornillo hexagonal Vis à tête hexagonale	M8 x 16 25Nm/18ft.lbs	DIN933 S3
720	5000033988	2	Lockwasher Spannscheibe	Arandela elástica Rondelle de ressort	10	DIN6796
798	5000172326	24	Flat washer Scheibe	Arandela elástica Rondelle de ressort	8.4	
1269	5200024514	1	Seal Kit Dichtungssatz	Juego-empaque Jeu-joint		
1276	5000171445	2	Exciter Shaft Kit w/o counterbore Erregerwellensatz ohne Senkung	Juego-eje del excitador s/escariador Jeu-arbre de l'excitatrice san		
1277	5000171446	2	Exciter Shaft Kit w/counterbore Erregerwellensatz mit Senkung	Juego-eje del excitador c/escariador Jeu-arbre de l'excitatrice ave		

Hydraulic Manifold
Hydraulikverteiler
Distribuidor Hidráulico
Tubulure Hydraulique

RTLx-SC3

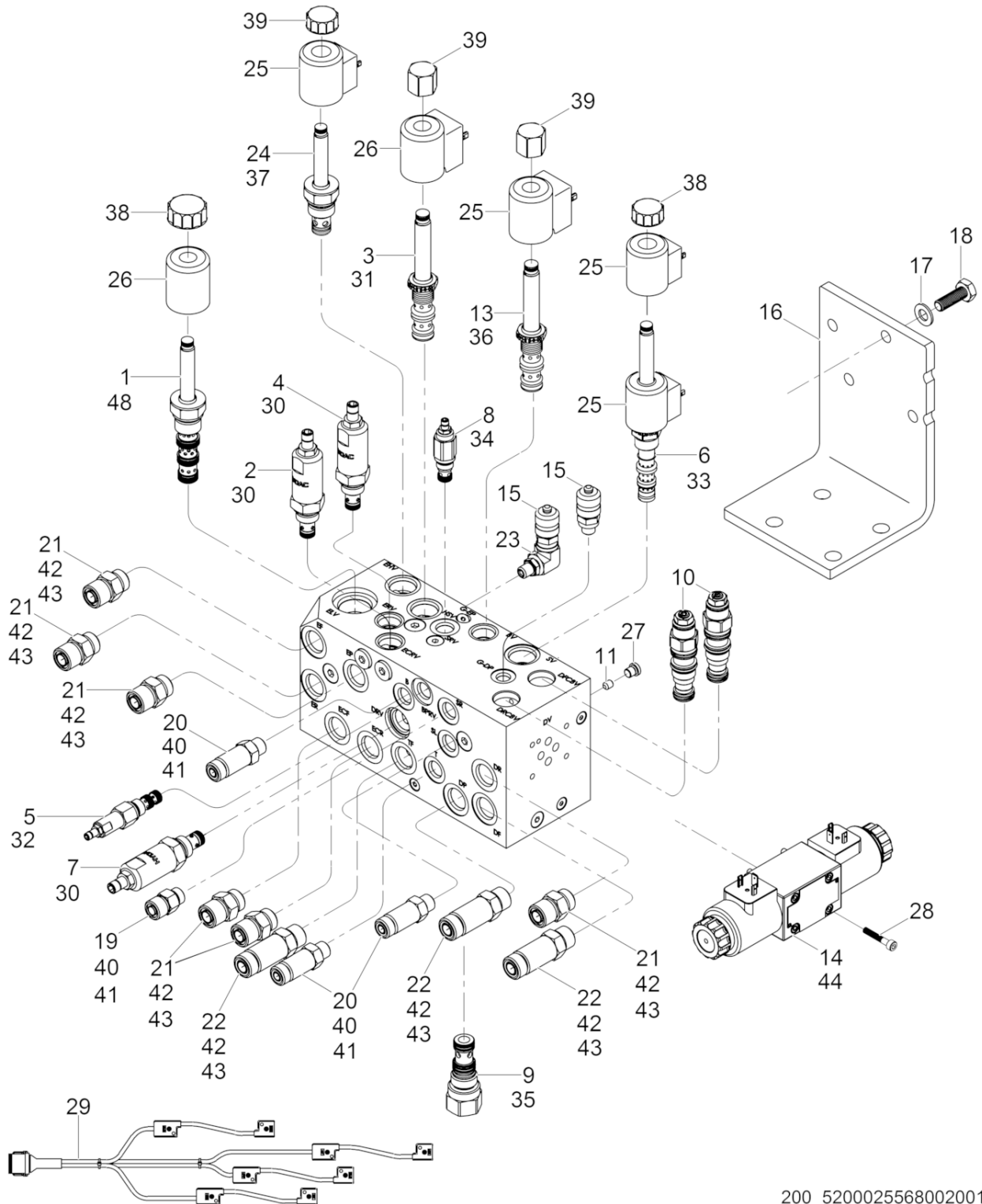

200_5200025568002001

Ref. Pos.	Part No. Artikel Nr.	Qty. St.	Description Beschreibung	Descripción Description	Measurem./Abm.	Norm
					Torque/Drehm.	Sealant Schmierstoff
1	5100016775	1	Solenoid valve Ventil-Solenoid	Válvula-solenoid Électrovanne		
2	5100016776	1	Relief valve Überdruckventil	Válvula de desahoga Soupape de surpression		
3	5100016777	1	Solenoid valve Ventil-Solenoid	Válvula-solenoid Électrovanne		
4	5100016778	1	Relief valve Überdruckventil	Válvula de desahoga Soupape de surpression		
5	5100016779	1	Brake valve Bremsventil	Válvula de frenaje Robinet de freinage		
6	5100016780	1	Steering valve Steuerventil	Válvula de dirección Soupape de direction		
7	5100016781	1	Relief valve Überdruckventil	Válvula de desahoga Soupape de surpression		
8	5100016782	1	Steering valve Steuerventil	Válvula de dirección Soupape de direction		
9	5100016783	1	Bypass valve Bypassventil	Válvula de desviador Soupape de dérivation		
10	5100016784	2	Counterbalance valve Ausgleichsventil	Válvula de compensación Soupape de contrecharge		
11	5100016785	1	Setscrew Gewindestift	Tornillo Vis	2,70	
12	5100016786	1	Setscrew Gewindestift	Tornillo Vis	0,80	
13	5100016787	1	Brake valve Bremsventil	Válvula de frenaje Robinet de freinage		
14	5100016788	1	Drive valve Antriebsventil	Válvula de mando Soupape d'entraînement		
15	5000182738	2	Test fitting w/cap Prüfverschraubung mit Kappe	Unión de prueba con tapa Raccord d'essai avec couvercle	M16 x 2, 7/16-20 UNC	
16	5100016789	1	Mounting bracket Konsole	Ménsula Support		
17	5000010621	3	Washer Scheibe	Arandela Rondelle		
18	5200015174	4	Screw Schraube	Tornillo Vis		
19	5000078816	1	Adapter fitting Zwischenverschraubung	Unión con adaptador Raccord intermédiaire		
20	5000158574	3	Fitting Verschraubung	Unión Raccord	No.6	
21	5000080558	6	Fitting Verschraubung	Unión Raccord		
22	5000158572	3	Fitting Verschraubung	Unión Raccord	No.8	
23	5100016790	1	Hydraulic fitting Hydraulikverschraubung	Unión hidráulico Raccord hydraulique	4 x 4	
24	5100016791	1	Exciter valve Erregung des Ventils	Excitador de válvula Excitation de valve		
25	5100016792	4	Coil Spule	Bobina Bobine	12V	

Hydraulic Manifold
Hydraulikverteiler
Distribuidor Hidráulico
Tubulure Hydraulique

RTLx-SC3

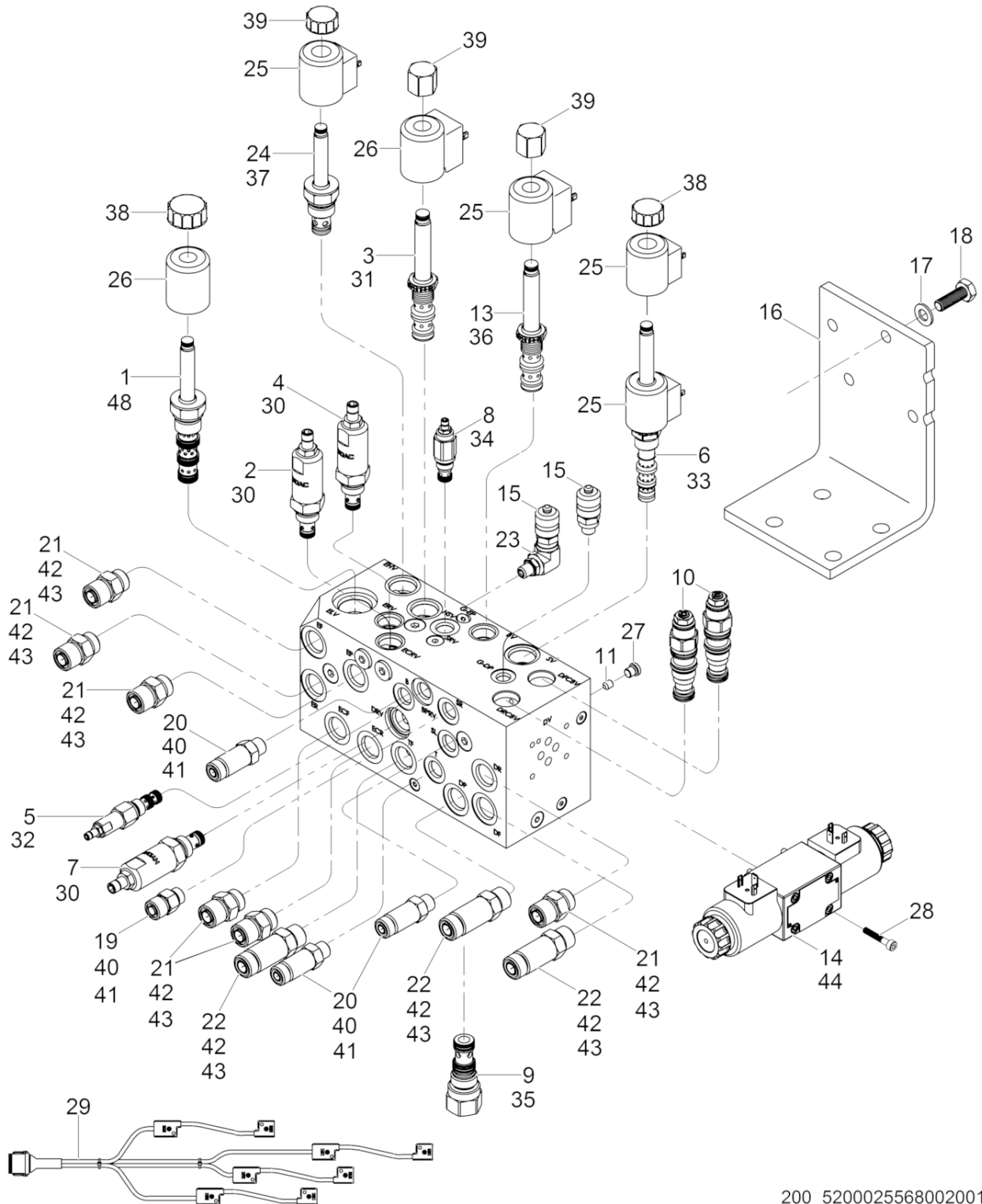

200_5200025568002001

Ref. Pos.	Part No. Artikel Nr.	Qty. St.	Description Beschreibung	Descripción Description	Measurement./Abm.	Norm
					Torque/Drehm.	Sealant Schmierstoff
26	5100016793	2	Coil Spule	Bobina Bobine	12V	
27	5100016794	9	Plug Stopfen	Tapón Bouchon	No. 2	
28	5000011558	4	Cheese head screw Zylinderschraube	Tornillo cilíndrico Vis à tête cylindrique	M5 x 30 10Nm/7ft.lbs	ISO4762
29	5200023703	1	Wiring harness Kabelbaum	Conjunto de cables Harnais de câbles électriques		
30	5100016796	3	Seal Kit Dichtungssatz	Juego-empaque Jeu-joint		
31	5100016797	1	Seal Kit Dichtungssatz	Juego-empaque Jeu-joint		
32	5100016798	1	Seal Kit Dichtungssatz	Juego-empaque Jeu-joint		
33	5100016799	1	Seal Kit Dichtungssatz	Juego-empaque Jeu-joint		
34	5100016800	1	Seal Kit Dichtungssatz	Juego-empaque Jeu-joint		
35	5100016801	1	Seal Kit Dichtungssatz	Juego-empaque Jeu-joint		
36	5100016802	1	Seal Kit Dichtungssatz	Juego-empaque Jeu-joint		
37	5100016803	1	Seal Kit Dichtungssatz	Juego-empaque Jeu-joint		
38	5100016804	2	Coil Kit Spule kpl.	Bobina compl. Bobine compl.		
39	5100016805	3	Coil Kit Ventilkappe	Bobina compl. Bobine compl.		
40	5000080731	4	O-Ring O-Ring	Anillo-O Joint torique	0,468 x 0,078in	
41	5000080736	4	O-Ring O-Ring	Anillo-O Joint torique	0,364 x 0,070in	
42	5000080732	9	O-Ring O-Ring	Anillo-O Joint torique	0,644 x 0,087in	
43	5000080737	9	O-Ring O-Ring	Anillo-O Joint torique	0,489 x 0,070in	
44	5100016873	1	Seal Kit Dichtungssatz	Juego-empaque Jeu-joint		
48	5100016795	1	Seal Kit Dichtungssatz	Juego-empaque Jeu-joint		

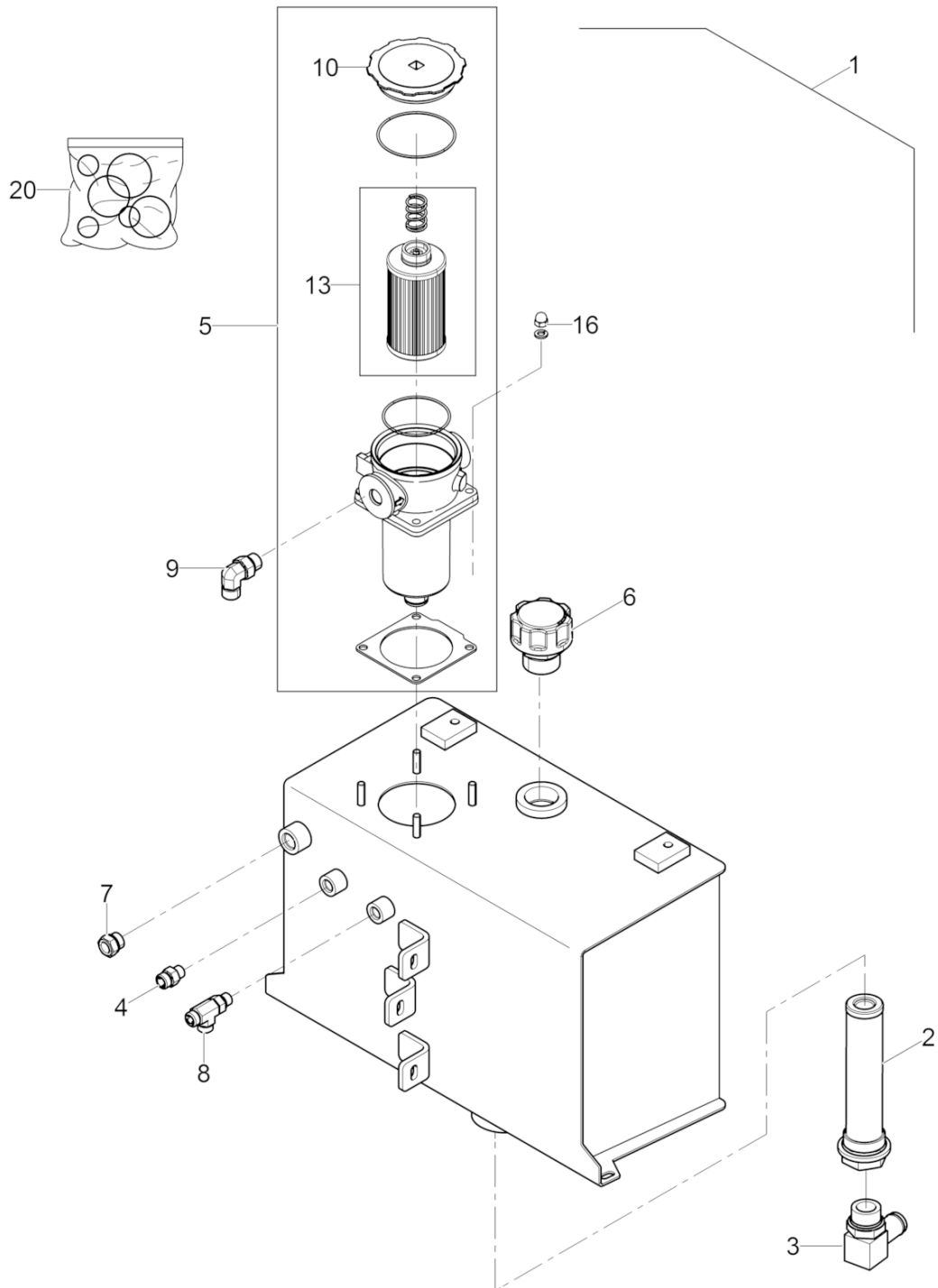

wc_ex0179971001

Ref. Pos.	Part No. Artikel Nr.	Qty. St.	Description Beschreibung	Descripción Description	Measurement./Abm.	Norm
					Torque/Drehm.	Sealant Schmierstoff
1	5200000844	1	Hydraulic tank Hydrauliktank	Tanque hidráulico Réservoir hydraulique		
2	5000182746	1	Suction strainer Saugkorb	Colador Crépine		
3	5000182747	1	Barbed fitting Verschraubung mit Widerhaken	Unión dentada Raccord à picot	No.6 x 90	
4	5000078816	1	Adapter fitting Zwischenverschraubung	Unión con adaptador Raccord intermédiaire		
5	5000182748	1	Return filter RückleitungsfILTER	Filtro de retorno Filtre de retour		
6	5200000845	1	Breather tube Entlüftungskappe	Tapa respiradero Capuchon reniflard		
7	5000116236	1	Sightglass Ölschauglas	Mirilla del nivel de aceite Verre-regard d'huile		
8	5000083412	1	Fitting Verschraubung	Unión Raccord		
9	5000111272	1	Hydraulic elbow fitting Hydraulikrohrkrümmer	Codo hidráulico Coude hydraulique	SAE No.8 x 90	
10	5000182750	1	Cover Deckel	Tapa Couvercle		
13	5000182752	1	Filter element Filterelement	Elemento del filtro Élément du filtre		
16	5000159508	4	Acorn nut Hutmutter	Tuerca Ecrou	M10	
20	5000182733	1	Gasket & O-Ring Set Dichtungs- u. O-Ringsatz	Juego de juntas/anillos-O Jeu de joints		

**Transmitter Module
Sender
Transmisor
Transmetteur**

RTLx-SC3

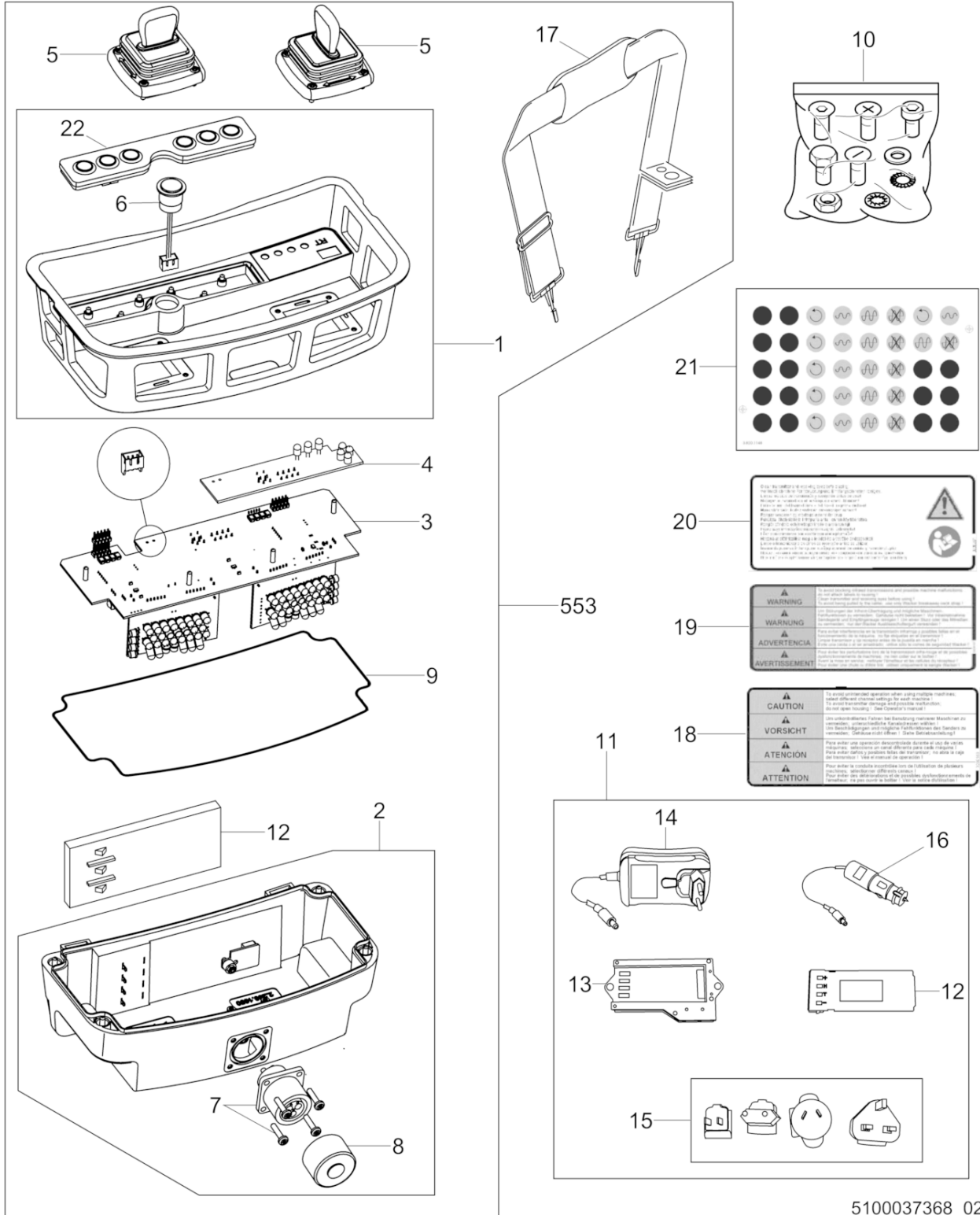

5100037368_02

Ref. Pos.	Part No. Artikel Nr.	Qty. St.	Description Beschreibung	Descripción Description	Measurem./Abm.	Norm
					Torque/Drehm.	Sealant Schmierstoff
1	5100029414	1	Upper housing Oberer Rahmen	Chasis superior Châssis supérieur		
2	5000180315	1	Lower housing Untere Umhüllung	Envoltura inferior Gaine inférieure		
3	5100044531	1	Circuit board Schaltplatte	Tablero de circuitos Carte de circuit		
4	5000180317	1	Circuit board display Schaltplattenausstellung	Presentación de tablero de circuitos Affichage de carte de circuit		
5	5000177083	2	Steering Lever Kit Steuerhebel-Satz	Palanca de Dirección-Juego Lever de Direction-Jeu		
6	5100044532	1	On/off switch Schalter, ein/aus	Interruptor, enc./apag. Interrupteur, marche/arrêt		
7	5100037365	1	3-Pin Connector 3-polige Buchse	Socket 3-pin 3 broches		
8	5000117184	1	Cap Kappe	Tapa Couvercle		
9	5000164704	1	Seal Dichtung	Empaque Joint		
10	5000180320	1	Hardware Kit Kleinteilesatz	Juego de piezas pequeñas Jeu de pièces		
11	5000213091	1	Charging Set Ladegerät	Juego de carga Jeu de charge		
12	5000210156	1	Battery Akku	Batería Accumulateur		
13	5000209760	1	Battery charger Ladegerät	Cargador par batería Chargeur de batteries		
14	5000209761	1	Electrical plug Steckernetzteil	Enchufe de alimentación Mains plug		
15	5000209762	1	Plug Adapter Set Steckeradapter-Set	Enchufe de alimentación Mains plug		
16	5000209763	1	Power cable Anschlusskabel	Cable de alimentación Cable d'alimentation		
17	5000114783	1	Band Band	Cinta Ruban		
18	5000209158	1	Instruction Label Aufkleber-Hinweis	Calcomanía-Indicación Autocollant avec Indication		
19	5000209157	1	Label-warning Aufkleber-Warnung	Calcomanía-Advertencia Autocollant-Avertissement		
20	5000226261	1	Label Aufkleber	Calcomanía Autocollant		
21	5200017125	1	Label sheet Aufkleberblatt	Hoja de calcomanías Feuille d'autocollants		
22	5100037750	1	Switch plate module Plattenmodul anschließen	Módulo de placa de interruptor Module de plaque d'interrupteur		
553	5000165514	1	Transmitter module Sender	Transmisor Transmetteur		



808

CHANGEL LABELS: REMOVE THE EXISTING CHANNEL ON BOTH TRANSMITTER AND RECEIVER. REPLACE ORIGINAL LABEL WITH NEW CHANNELS AND CHANGE.	1	1	9	9
KANALUMSÄTZER: ENTFERNEN SIE DEN BESTEHENDEN KANAL BEI BEIDEN TRANSMITTER UND EMPFÄNGER. ERSETZEN SIE DIE URSÜNGLICHEN AUFKLEBER MIT DEN NEUEN KANÄLEN UND VERÄNDERN SIE DIE KANÄLE.	2	2	0	0
CAJONERAS PARA CANAL: REMOVER EL CANAL EXISTENTE, TANTO EN EL TRANSMISOR COMO EN EL RECEPTOR. REEMPLAZAR LAS CALCOMANIAS ORIGINALES POR LAS CALCOMANIAS NUEVAS CUANDO CAMBIE LOS CANALES.	3	3	A	A
AUTOCOLLANT POUR CANAL: REMOVER LE CANAL EXISTANT, TANT AU ÉMETTEUR QU'AU RÉCEPTEUR. REMPLACER L'AUTOCOLLANT ORIGINAL PAR UN AUTOCOLLANT NOUVEAU QUAND LES CANAUX SONT CHANGÉS.	4	4	B	B
	5	5	C	C
	6	6	D	D
	7	7	E	E
	8	8	F	F

807

805

1301

ULTRA LOW SULFUR FUEL ONLY.
NUR ULTRANIEDRIGEN SCHWEFELKRAFTSTOFF.
SOLAMENTE COMBUSTIBLE DE ULTRABAJO CONTENIDO DE AZUFRE.
SEULEMENT CARBURANT DE SOUFRE ULTRA BAS.

816

801—RTSC3
802—WACKER
NEUSON

200_5200019232100015

Ref. Pos.	Part No. Artikel Nr.	Qty. St.	Description Beschreibung	Descripción Description	Measurement./Abm.	Norm
					Torque/Drehm.	Sealant Schmierstoff
801	5200023102	2	Label Aufkleber	Calcomania Autocollant		
802	5000222136	2	Label-logo Aufkleber, Logo	Calcomanía-logotipo Autocollant - logo	100 OD	
805	5200022195	1	Label sheet Aufkleberblatt	Hoja de calcomanias Feuille d'autocollants		
807	5000171055	1	Label Aufkleber	Calcomania Autocollant		
808	5000222087	2	Label Symbol Aufkleber Symbol	Calcomania Símbololo Autocollant Symbole	120 OD	
816	5000177416	1	Label-diesel fuel Aufkleber	Calcomania Autocollant		
1301	5200022197	1	Label sheet-EU Aufkleberblatt-EU	Hoja de calcomanias-EU Feuille d'autocollants-EU		



**WACKER
NEUSON**

**Engine-Kohler
Kohler-Motor
Motor Kohler
Moteur Kohler**

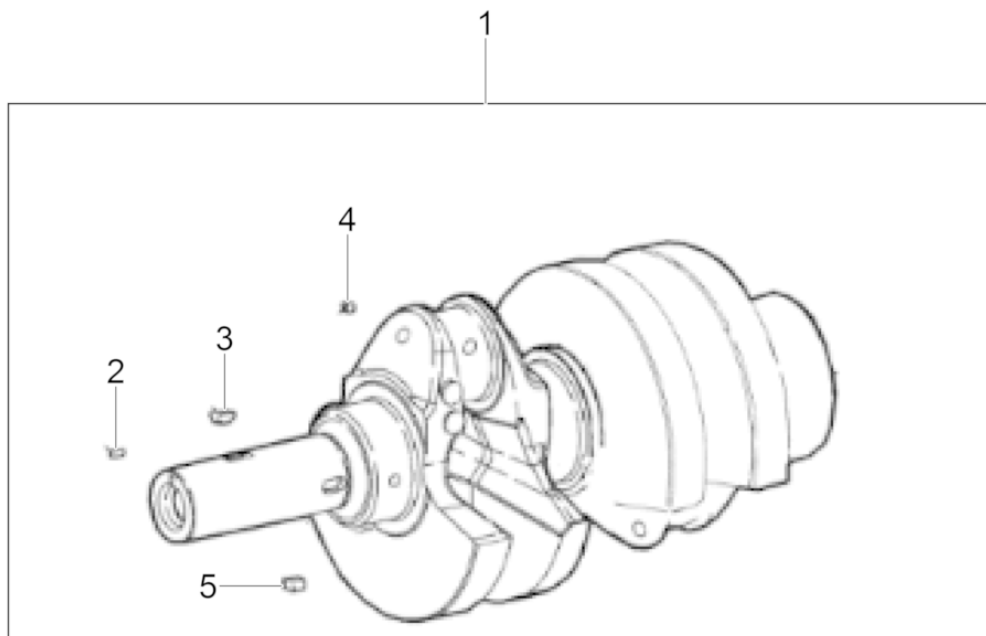

200_5200015979001001

Ref. Pos.	Part No. Artikel Nr.	Qty. St.	Description Beschreibung	Descripción Description	Measurement./Abm.	Norm
					Torque/Drehm.	Sealant Schmierstoff
1	5000160365	1	Crankshaft Kurbelwelle	Cigüeñal Vilebrequin		
2	5000159357	1	Pin Stift	Espiga Goupille		
3	5000159260	1	Woodruff key Woodruffkeil	Chaveta Woodruff Clavette Woodruff		
4	5000159454	3	Plug (threaded) Schraubverschluß	Tapón roscado Bouchon		
5	5000159261	1	Square key Passfeder	Chaveta Clavette		

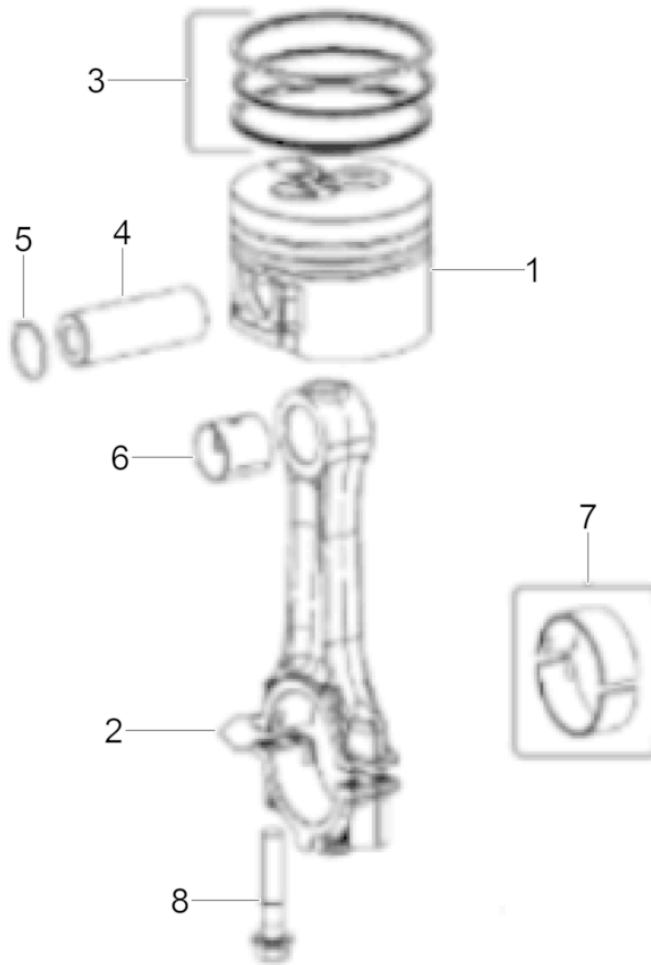

200_5200015979001002

Ref. Pos.	Part No. Artikel Nr.	Qty. St.	Description Beschreibung	Descripción Description	Measurem./Abm.	Norm
					Torque/Drehm.	Sealant Schmierstoff
1	5000160375	3	Set Of Piston Kolbensatz	Juego de Pistón Jeu de Piston		
1	5000160376	3	Set Of Piston Kolbensatz	Juego de Pistón Jeu de Piston		
1	5000160377	3	Set Of Piston Kolbensatz	Juego de Pistón Jeu de Piston		
2	5000160367	3	Connecting rod Pleuel	Biela Bielle		
3	5000160383	2	Piston Ring Set Kolbenringsatz	Juego de cubo levantador Jeu de moyeu de levage		
3	5000160384	2	Kit-lift ring Ringsatz	Juego de cubo levantador Jeu de moyeu de levage		
3	5000160385	2	Kit-lift ring Ringsatz	Juego de cubo levantador Jeu de moyeu de levage		
4	5000215523	3	Piston pin Kolbenbolzen	Perno de pistón Axe de piston		
5	5000215477	6	Retaining ring Sicherungsring	Anillo de retención Bague d'arrêt		
6	5000160368	2	Bushing Buchse	Buje Douille		
7	5000155689	2	Bearing Lagerschalen	Rodamiento Roulement		
7	5000155690	2	Bearing Pleuellagerangen	Rodamiento Roulement		
7	5000155691	2	Bearing Pleuellagerangen	Rodamiento Roulement		
8	5000084175	4	Screw Schraube	Tornillo Vis		

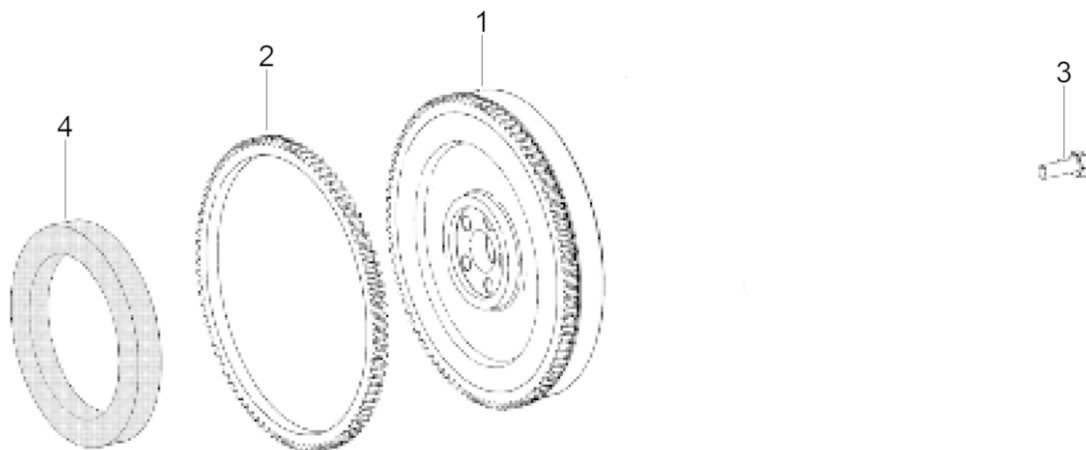

200_5200015979001003

Ref. Pos.	Part No. Artikel Nr.	Qty. St.	Description Beschreibung	Descripción Description	Measurement/Abm.	Norm
					Torque/Drehm.	Sealant Schmierstoff
1	5000159485	1	Flywheel compl. Schwungrad kpl.	Volante compl. Volant compl.		
2	5000155692	1	Connecting rod Pleuel	Biela Bielle		
3	5000160188	5	Bolt Bolzen	Perno Boulon		
4	5000159258	1	Rotor Rotor	Rotor Rotor		

Pulley cpl.
Scheibensatz
Conjunto Cabrestante
Ensemble Poulie

RTLx-SC3

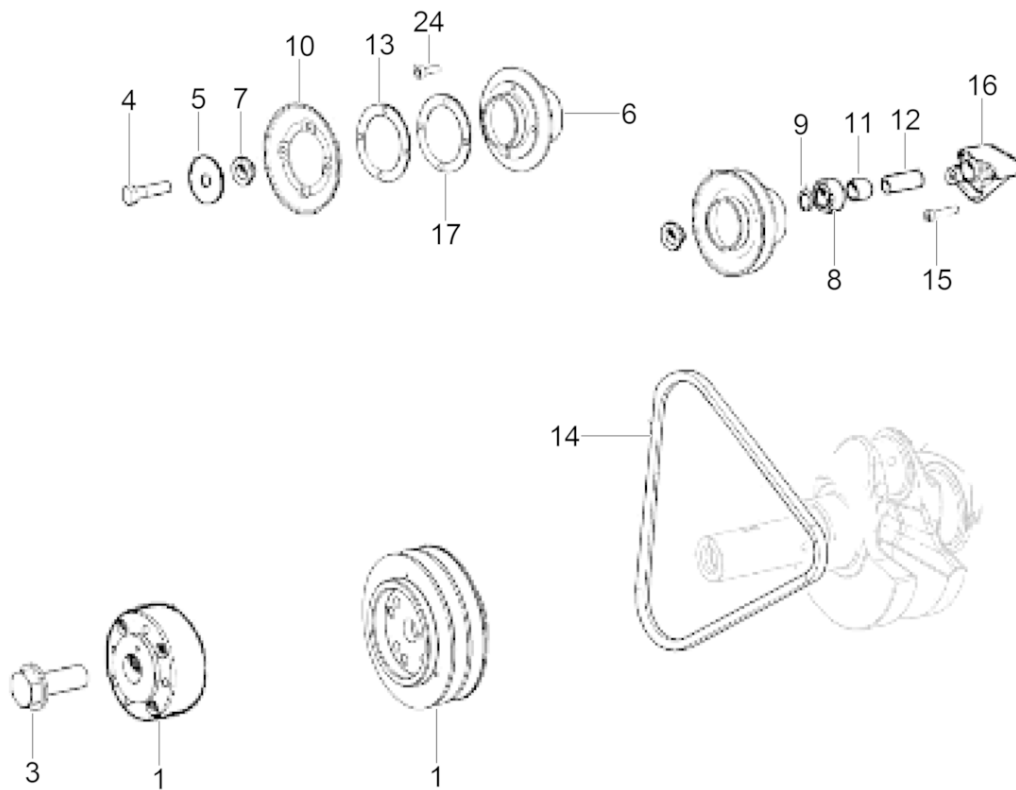

200_5200015979001004

Ref. Pos.	Part No. Artikel Nr.	Qty. St.	Description Beschreibung	Descripción Description	Measurem./Abm.	Norm
					Torque/Drehm.	Sealant Schmierstoff
1	5000155723	1	Crankshaft pulley Scheibe	Disco Rondelle		
3	5000126935	1	Bolt Bolzen	Perno Boulon		
4	5000159490	1	Bolt Bolzen	Perno Boulon	M8x1.25x90	
5	5000159346	1	Washer Scheibe	Disco Rondelle		
6	5000159345	1	Pulley cpl. Konsole kpl.	Consola cpl. Console cpl.		
6	5200023964	1	Pulley Scheibe	Polea Poulie		
7	5000159347	1	Washer Scheibe	Disco Rondelle		
8	5000082135	2	Bearing Lager	Cojinete Palier		
9	5000159241	2	Retaining ring Sicherungsring	Anillo de retención Bague d'arrêt		
10	5000207987	1	V-belt pulley half Riemenscheibenhälfte	Semi polea en V Flanc de poulie à courroie		
11	5000159277	1	Spacer Abstandsstück	Espaciador Pièce d'écartement		
12	5000159489	1	Pin Stift	Espiga Goupille	63,5	
13	5000207988	2	Distance washer Abstandsscheibe	Arandela distanciador Rondelle intermédiaire	0,5	
14	5000159262	1	Belt Riemen	Correa Courroie		
15	5000083026	3	Screw Schraube	Tornillo Vis	M8x35	
16	5000159448	1	Console Konsole	Consola Console		
17	5000207989	4	Distance washer Abstandsscheibe	Arandela distanciador Rondelle intermédiaire	1,0	
24	5000159475	4	Screw Schraube	tornillo vis		

Cylinder Head
 Zylinderkopf
 Culata
 Culasse

RTLx-SC3

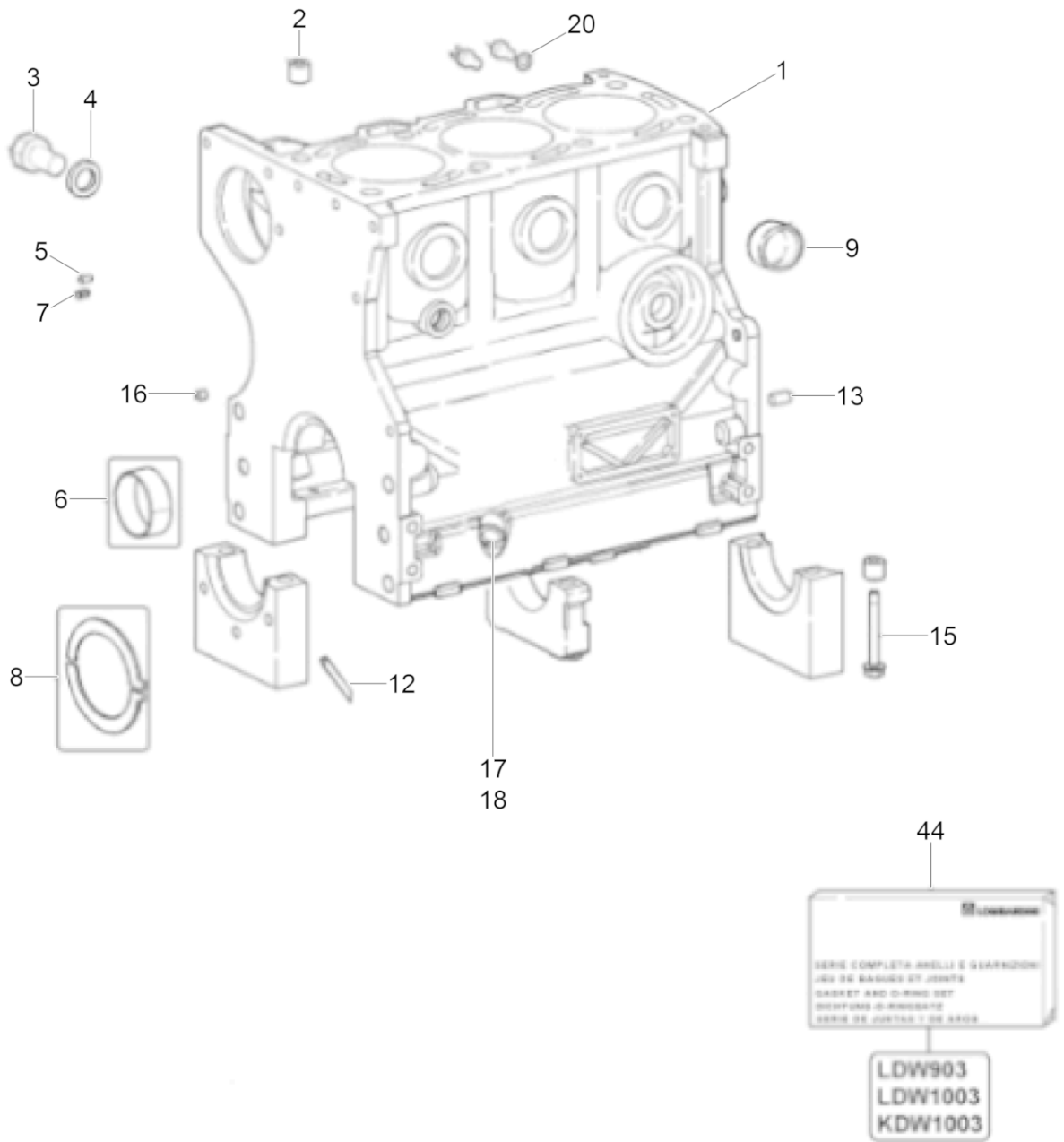

200_5200015979001005

Ref. Pos.	Part No. Artikel Nr.	Qty. St.	Description Beschreibung	Descripción Description	Measurem./Abm.	Norm
					Torque/Drehm.	Sealant Schmierstoff
1	5000160388	1	Cylinder head Zylinderkopf	Culata Culasse		
5	5000159449	2	Plug Stopfen	Enchufe Prise		
6	5000159318	3	Spark arrester Funkenfänger	Parachispas Pare-étincelles		
7	5000215524	2	Lifting point Aufhängung	Punto para itar Suspension		
8	5000084156	1	Screw Schraube	Tornillo Vis		
9	5000159479	8	Bolt Bolzen	Perno Boulon		
10	5000159350	8	Washer Scheibe	Arandela Rondelle		
11	5000159231	1	O-ring O-ring	Anillo en forma de o Joint torique		
13	5000159311	1	Bracket Halter	Soporte Équerre		
14	5000159254	1	Bolt Bolzen	Perno Boulon		
15	5000082292	1	Washer Scheibe	Arandela Rondelle		
17	5000159303	6	Valve guide Ventilführung	Guía de válvula Guide de soupape		
18	5000160381	3	Seat-valve, intake Sitz des Einlassventils	Asiento de la válvula de admisión Siège de la soupape		
19	5000160382	3	Seat-valve, exhaust Sitz des Auslassventils	Asiento de la válvula de escape Siège de la soupape		
23	5000159285	3	Nut Mutter	Tuerca Ecrou		
24	5000215494	9	Spacer Abstandsstück	Espaciador Pièce d'écartement		
25	5000160380	3	Precombustion chamber Vorkammer	Cámara de precombustión Préchambre		
26	5000160369	1	Cylinder head gasket (1) notch Zylinderkopfdichtung mit Schlitz (1)	Junta de culata del cilindro con entalladura (1) Joint de culasse de cylindre a		
26	5000160370	1	Cylinder head gasket (2) notch Zylinderkopfdichtung mit Schlitz (2)	Junta de culata del cilindro con entalladura (2) Joint de culasse de cylindre a		
26	5000160371	1	Cylinder head gasket (3) notch Zylinderkopfdichtung mit Schlitz (3)	Junta de culata del cilindro con entalladura (3) Joint de culasse de cylindre a		
33	5200009477	1	Gasket set Dichtungssatz	Juego de juntas Jeu de joints		

Crankcase
Kurbelgehäuse
Cárter
Carter

RTLx-SC3

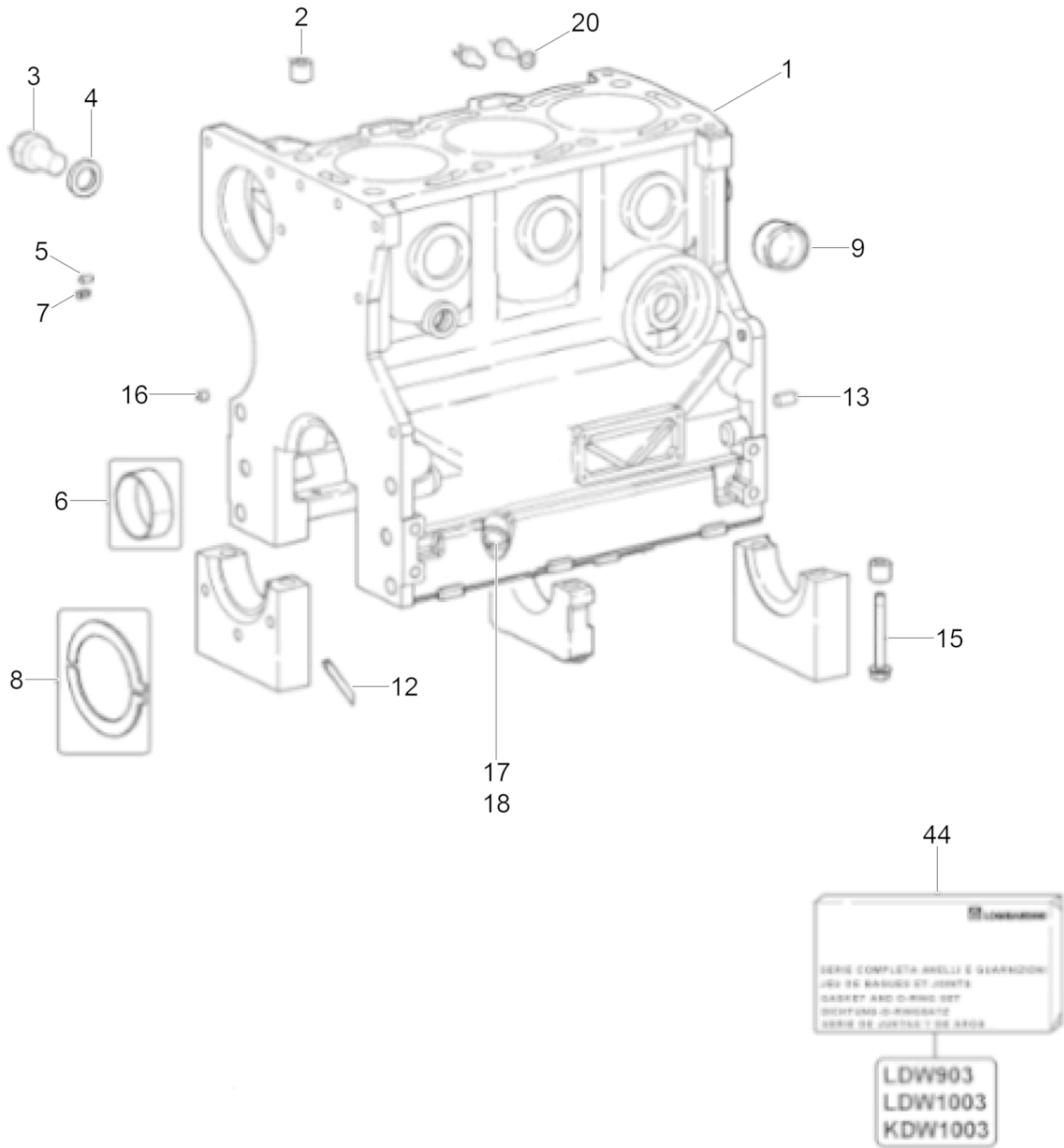

200_5200015979001005

Ref. Pos.	Part No. Artikel Nr.	Qty. St.	Description Beschreibung	Descripción Description	Measurem./Abm.	Norm
					Torque/Drehm.	Sealant Schmierstoff
1	5000210344	1	Crankcase Kurbelgehäuse	Cárter Carter		
2	5000159257	2	Sleeve Hülse	Collar Douille		
3	5000206229	1	Screw Schraube	Tornillo Vis		
4	5000082184	1	Ring seal Dichtring	Anillo sellador Rondelle à étancher		
5	5000215522	1	Pin Stift	Espiga Goupille		
6	5000155702	3	Bearing Lager	Cojinete Palier		
6	5000155703	3	Bearing Lager	Cojinete Palier		
6	5000155704	3	Bearing Lager	Cojinete Palier		
8	5000159486	2	Washer Scheibe	Disco Rondelle		
8	5000159487	2	Disc Scheibe	Disco Disque		
8	5000159488	2	Disc Scheibe	Disco Disque		
9	5000082335	4	Plug (threaded) Schraubverschluß	Tapón roscado Bouchon		
12	5000159288	4	Gasket Dichtung	Junta Joint		
13	5000159360	2	Dowel pin Paßstift	Espiga Cheville		
15	5000159480	8	Screw Schraube	Tornillo Vis		
16	5000159456	1	Plug Stopfen	Tapón Bouchon		
17	5000159299	1	Washer Scheibe	Disco Rondelle		
18	5000215530	1	Plug Stopfen	Enchufe Prise		
20	5000082183	1	Ring seal Dichtring	Anillo sellador Rondelle à étancher		
44	5000159397	1	Crankcase Gasket Set Dichtungssatz, Kurbelgehäuse	Juego de juntas, cárter Jeu de joints, carter		

Cylinder Head Cover
Zylinderkopfhaube
Tapa del Cilindro
Couvercle Supérieur

RTLx-SC3

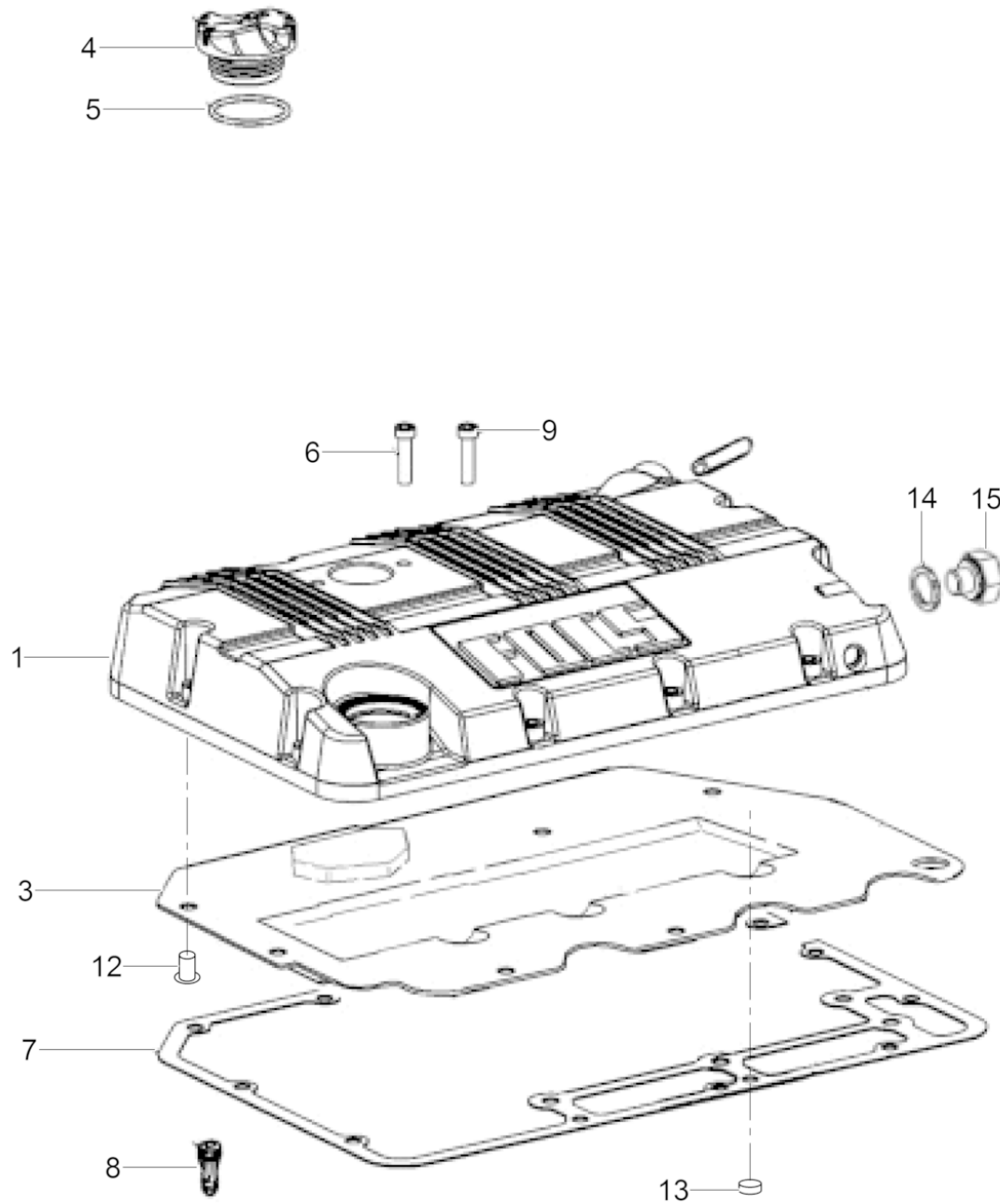

200_5200015979001007

Ref. Pos.	Part No. Artikel Nr.	Qty. St.	Description Beschreibung	Descripción Description	Measurement./Abm.	Norm
					Torque/Drehm.	Sealant Schmierstoff
1	5000210346	1	Valve cover Ventilhaube	Tapa de válvula Couvercle de soupape		
3	5000159305	1	Baffle Leitblech	Deflector Déflecteur		
4	5000210347	1	Cap Kappe	Tapa Couvercle		
5	5000206208	1	O-ring O-ring	Anillo en forma de o Joint torique		
6	5200009533	10	Screw Schraube	Tornillo Vis	M10 x 30	
7	5000160205	1	Gasket Dichtung	Junta Joint		
8	5000159308	1	Connector Anschlußteil	Conector Connexion		
9	5000215544	2	Screw Schraube	Tornillo Vis		
12	5200015519	9	Rivet Niet	Remache Rivet		
13	5000159455	1	Push-in plug Stopfen	Tapón Bouchon		
14	5000082184	1	Ring seal Dichtring	Anillo sellador Rondelle à étancher		
15	5000082331	1	Plug (threaded) Schraubverschluß	Tapón roscado Bouchon		

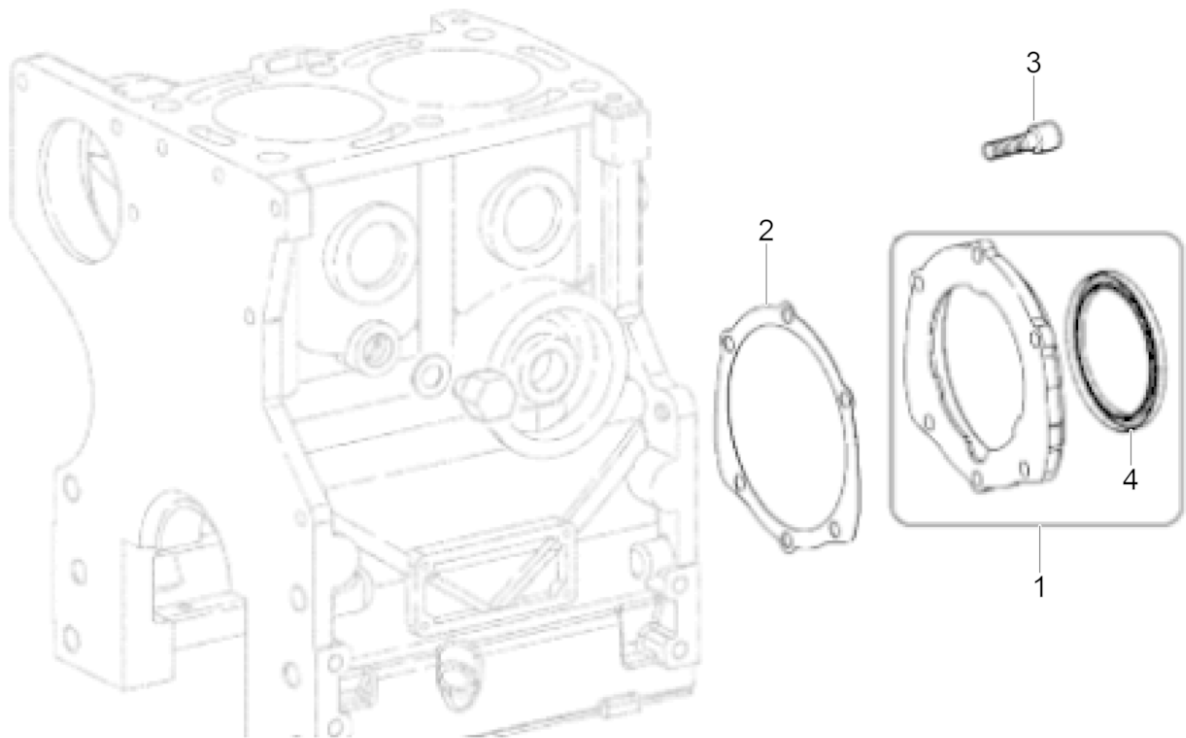

200_5200015979001008

Ref. Pos.	Part No. Artikel Nr.	Qty. St.	Description Beschreibung	Descripción Description	Measurem./Abm.	Norm
					Torque/Drehm.	Sealant Schmierstoff
1	5000159281	1	Flange Cover Blindflansch	Palanca de Cubierta Semelle		
2	5000159296	1	Gasket Dichtung	Junta Joint		
3	5200023965	6	Screw Schraube	Tornillo Vis		
4	5000103314	1	Ring seal Wellendichtring	Anillo sellador Rondelle à étancher		

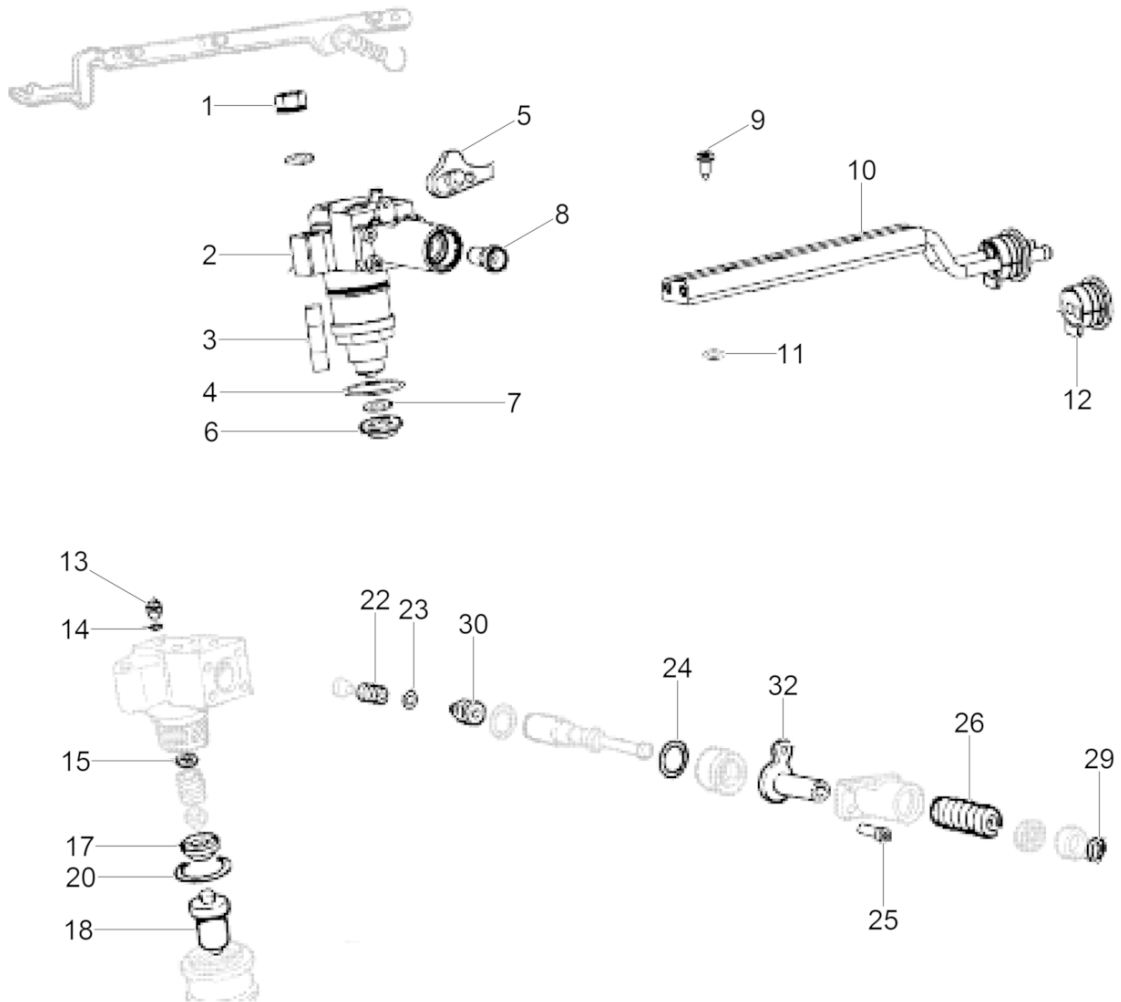

200_5200015979001009

Ref. Pos.	Part No. Artikel Nr.	Qty. St.	Description Beschreibung	Descripción Description	Measurem./Abm.	Norm
					Torque/Drehm.	Sealant Schmierstoff
1	5000063700	6	Flange nut Flanschmutter	Tuerca de reborde Ecrou de bride		
2	5000160379	3	Injection pump Einspritzpumpe	Bomba de inyección Pompe à injection		
3	5200009479	6	Stud Gewindebolzen	Perno prisionero Goujon		
4	5000159233	2	O-Ring O-Ring	Anillo-O Joint torique		
5	5000159325	1	Plate Platte	Placa Plaque		
7	5000159300	3	Washer Scheibe	Disco Rondelle		
9	5000159473	6	Screw Schraube	Tornillo Vis		
10	5000159459	1	Pipe Rohr	Tubo Conduit		
11	5000159237	2	Ring Ring	Anillo Anneau		
12	5000160209	1	Gasket Dichtung	Junta de estanqueidad Garniture		
13	5000160391	2	Back pressure valve Rückschlagventil	Válvula de retención Soupape de retenue		
14	5000159302	2	Gasket Dichtung	Junta de estanqueidad Garniture		
15	5200009480	1	Spacer Abstandsstück	Espaciador Entretoise	2,00	
15	5200009490	1	Spacer Abstandsstück	Espaciador Entretoise	2,00	
15	5200009489	1	Spacer Abstandsstück	Espaciador Entretoise	2,00	
15	5200009488	1	Spacer Abstandsstück	Espaciador Entretoise	1,2	
15	5200009487	1	Spacer Abstandsstück	Espaciador Entretoise	2,00	
15	5200009486	1	Spacer Abstandsstück	Espaciador Entretoise	2,00	
15	5200009485	1	Spacer Abstandsstück	Espaciador Entretoise	2,00	
15	5200009484	1	Spacer Abstandsstück	Espaciador Entretoise	1,40	
15	5200009482	1	Spacer Abstandsstück	Espaciador Entretoise	1,70	
15	5200009481	1	Spacer Abstandsstück	Espaciador Entretoise	1,80	
17	5000159278	2	Spacer Abstandsstück	Espaciador Pièce d'écartement		
18	5000155710	2	Jet Düse	Chicler Gicleur		
20	5000159238	2	O-ring O-Ring	Anillo-O Bague-O		

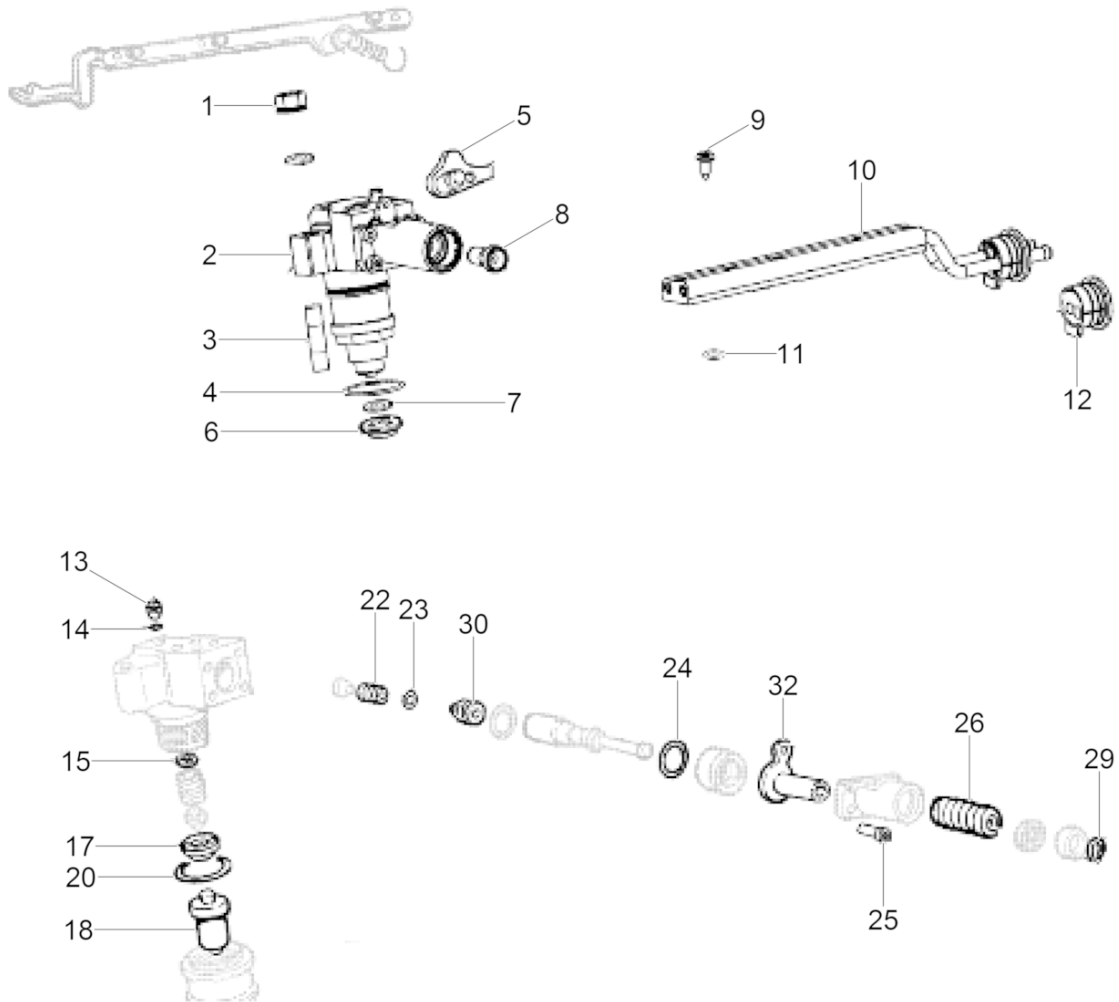

200_5200015979001009

Ref. Pos.	Part No. Artikel Nr.	Qty. St.	Description Beschreibung	Descripción Description	Measurement./Abm.	Norm
					Torque/Drehm.	Sealant Schmierstoff
22	5200009491	2	Spring Feder	Resorte Ressort		
23	5200009492	2	Gasket Dichtung	Junta Joint		
24	5000159236	2	Ring Ring	Anillo Anneau		
25	5000159471	4	Screw Schraube	Tornillo Vis		
26	5000159317	2	Spring Feder	Resorte Ressort		
29	5000159242	2	Clamp Klemme	Abrazadera Pince		
30	5200015520	2	Pressure valve Überdruckventil	Válvula de sobrepresión Soupape de surpression		
32	5000159309	2	Shim Ausgleichscheibe	Laminita Cale		

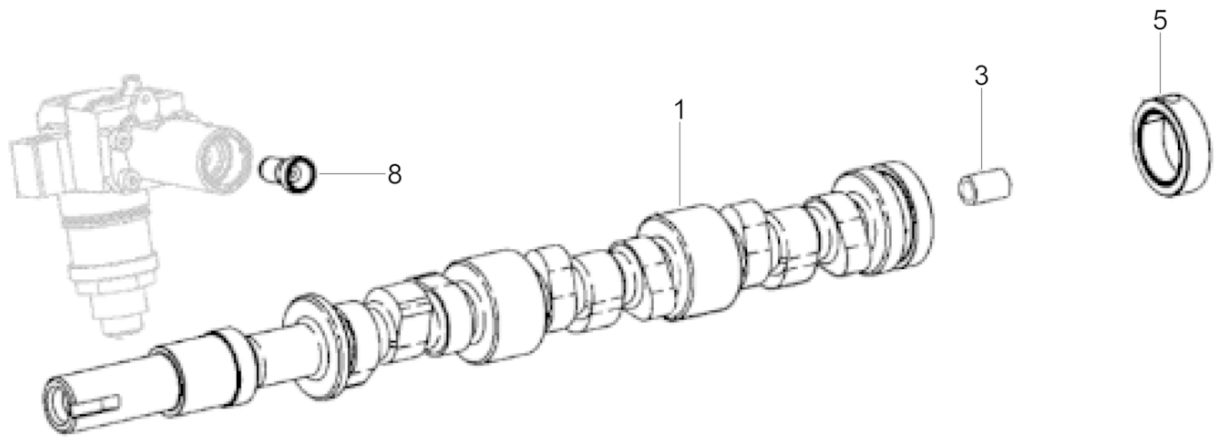

200_5200015979001010

Ref. Pos.	Part No. Artikel Nr.	Qty. St.	Description Beschreibung	Descripción Description	Measurement./Abm.	Norm
					Torque/Drehm.	Sealant Schmierstoff
1	5000160751	1	Camshaft Nockenwelle	Arbol de levas Arbre à cames		
3	5000160752	1	Sleeve Hülse	Manguito Douille		
5	5000160753	1	Injector cam Einspritznocken	Leva inyectora Came d'injection		
8	5000159246	2	Push rod (valve lifter) Stoßstange	Levantaválvula Poussoir de soupape		

Rocker Arms/Valves
Kipphebel/Ventile
Balancines/Válvulas
Culbuteurs/Soupapes

RTLx-SC3

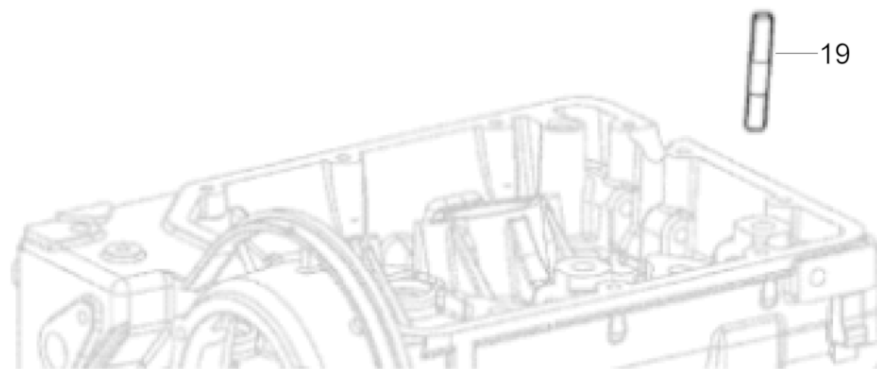
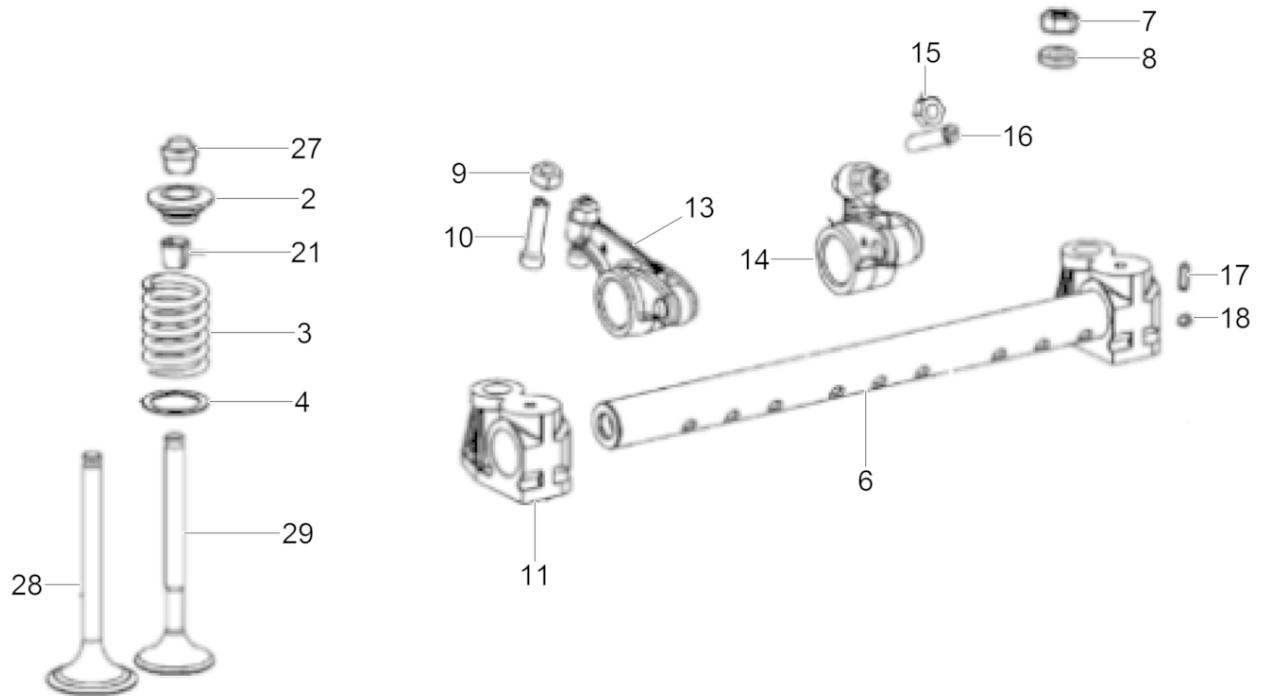

200_5200015979001011

Ref. Pos.	Part No. Artikel Nr.	Qty. St.	Description Beschreibung	Descripción Description	Measurement./Abm.	Norm
					Torque/Drehm.	Sealant Schmierstoff
2	5000159328	4	Spring Housing Federgehäuse	Carcasa de Resorte Logement du Ressort		
3	5000160373	6	Spring Ventilfeder	Resorte Ressort		
4	5000159351	6	Washer Scheibe	Disco Rondelle		
6	5000155696	1	Rocker arm cpl. Kipphebel kpl.	Balancín compl. Culbuteur compl.		
6	5000160218	1	Rocker arm shaft Kipphebelwelle	Eje del balancín Arbre du culbuteur		
7	5000083011	4	Nut Mutter	Tuerca Ecrou		
8	5000159350	4	Washer Scheibe	Arandela Rondelle		
9	5000159272	1	Nut Mutter	Tuerca Écrou		
10	5000159482	1	Screw Schraube	Tornillo Vis		
11	5200009458	4	Shaft support Kipphebelbolzenkonsole	Soporte del eje de balancín Support de l'arbre de bascule		
13	5000159248	6	Rocker arm Kipphebel	Balancín Culbuteur		
14	5000159249	3	Rocker arm injector Kipphebel Einspritzdüse	Inyector de balancines L'injecteur de culbuteur		
15	5000159275	1	Nut Mutter	Tuerca Ecrou		
16	5000159483	1	Threaded bolt Gewindebolzen	Perno roscado Boulon fileté		
17	5000159443	1	Pin Stift	Espiga Goupille		
18	5200009500	2	Plug Stopfen	Tapón Bouchon		
19	5000159333	4	Threaded bolt Gewindebolzen	Perno roscado Boulon fileté		
21	5200015522	12	Locking ring Klemmring	Anillo de sujeción Anneau serrure		
27	5000159297	6	Gasket Dichtung	Junta Joint		
28	5000160390	3	Intake valve Einlaßventil	Válvula de admisión Soupape d'admission		
29	5000160392	3	Outlet valve Auslaßventil	Válvula de escape Soupape d'échappement		

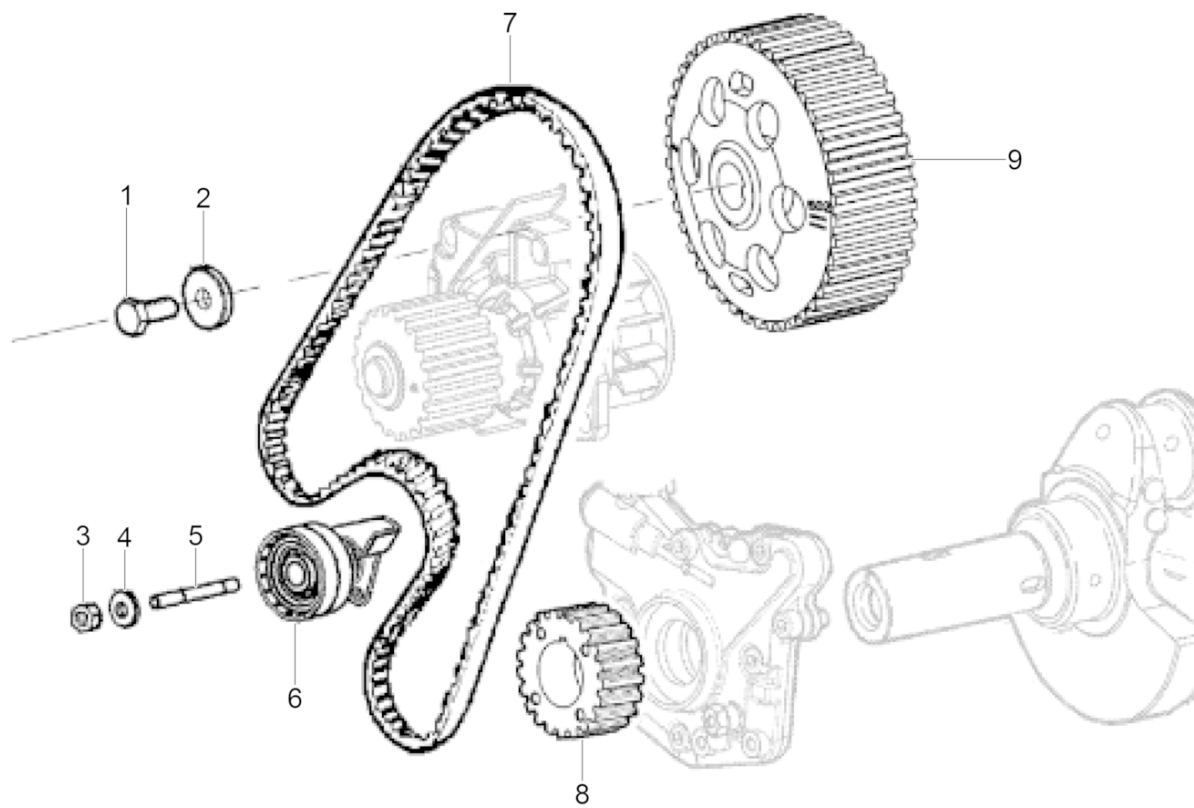

200_5200015979001012

Ref. Pos.	Part No. Artikel Nr.	Qty. St.	Description Beschreibung	Descripción Description	Measurement./Abm.	Norm
					Torque/Drehm.	Sealant Schmierstoff
1	5000159481	1	Screw Schraube	Tornillo Vis		
2	5000159349	1	Washer Scheibe	Disco Rondelle		
3	5000083011	1	Nut Mutter	Tuerca Ecrou		
4	5000159334	1	Threaded bolt Gewindebolzen	Perno roscado Boulon fileté		
5	5000159334	1	Threaded bolt Gewindebolzen	Perno roscado Boulon fileté		
6	5000159284	1	Tensioner pulley Spannrolle	Polea tensora Poulie de tension		
7	5000155697	1	Timing belt Synchronriemen	Correa de sincronización Courroie de synchronisation		
8	5000159336	1	V-belt pulley Riemenscheibe	Polea Poulie		
9	5000159338	1	V-belt pulley Riemenscheibe	Polea Poulie		

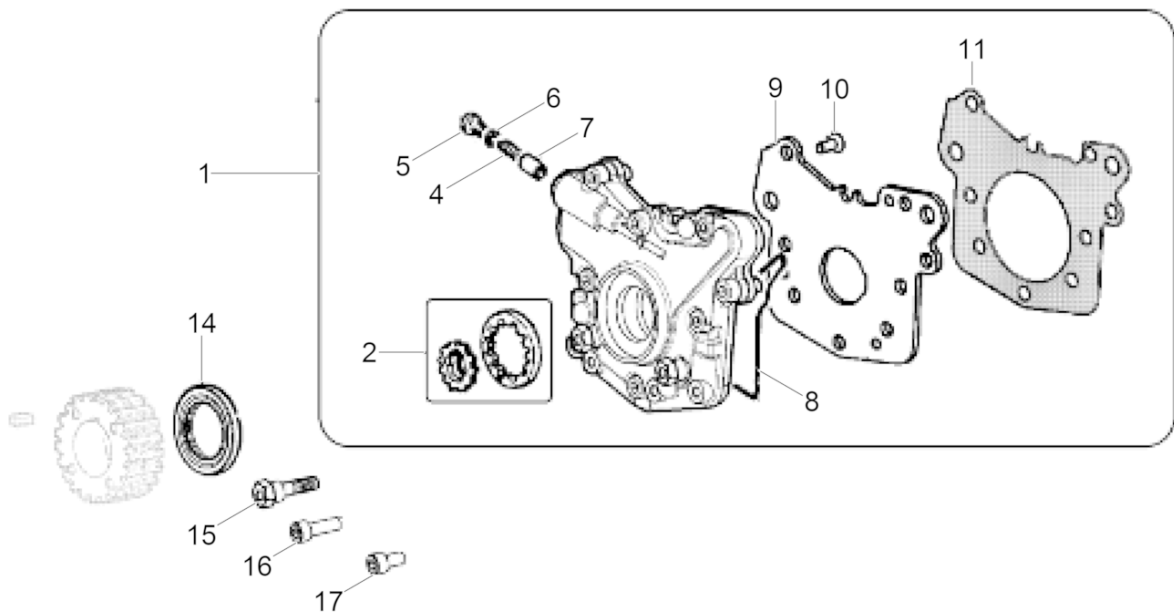

200_5200015979001013

Ref. Pos.	Part No. Artikel Nr.	Qty. St.	Description Beschreibung	Descripción Description	Measurement/Abm.	Norm
					Torque/Drehm.	Sealant Schmierstoff
1	5000155735	1	Oil pump cpl. Ölpumpe kpl.	Bomba de aceite compl. Pompe à huile compl.		
2	5200009456	1	Rotor Rotor	Rotor Rotor		
4	5000159312	1	Spring Feder	Resorte Ressort		
5	5000159450	1	Screw Locking Schraubverschluß	Cierre Roscada Fermeture de Vissage		
6	5000082184	1	Ring seal Dichtring	Anillo sellador Rondelle à étancher		
7	5000159330	1	Rod Stange	Varilla Tige		
8	5000160178	1	O-Ring O-Ring	Anillo-O Joint torique		
10	5000159478	3	Screw Schraube	Tornillo Vis		
11	5000215709	1	Gasket Dichtung	Junta de estanqueidad Garniture		
14	5000155734	1	Ring seal Dichtungsring	Anillo sellador Rondelle à étancher		
15	5000159484	2	Screw Schraube	Tornillo Vis		
16	5000215479	1	Hexagonal head cap screw Sechskantschraube	Tornillo hexagonal Vis à tête hexagonale		
17	5000084169	6	Screw Schraube	tornillo vis		

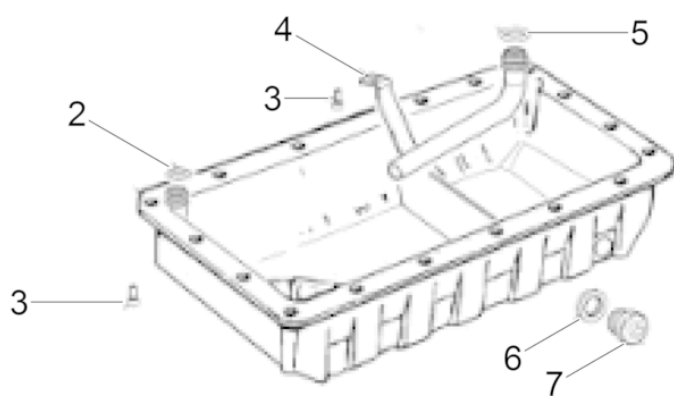
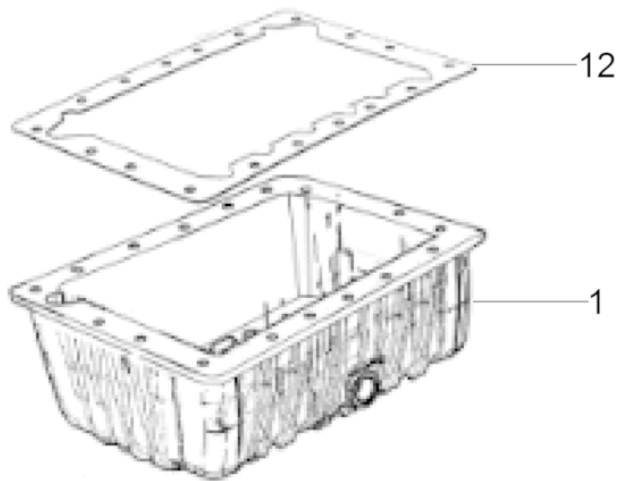

200_5200015979001014

Ref. Pos.	Part No. Artikel Nr.	Qty. St.	Description Beschreibung	Descripción Description	Measurement./Abm.	Norm
					Torque/Drehm.	Sealant Schmierstoff
1	5000155738	1	Oil pan Ölwanne	Colector de aceite Cuvette-carter à huile		
2	5000159228	1	Oil Seal Öldichtung	Junta de Aceite Joint D'Huile		
3	5000159253	19	Bolt Bolzen	Perno Boulon		
4	5000155737	1	Hose Schlauch	Manguera Tuyau		
5	5000159235	1	O-Ring O-Ring	Anillo-O Joint torique		
6	5000159568	2	Washer Scheibe	Arandela Rondelle		
11	5000159452	2	Plug Stopfen	Tapón Bouchon	M18	
12	5000159291	1	Gasket Dichtung	Junta Joint		

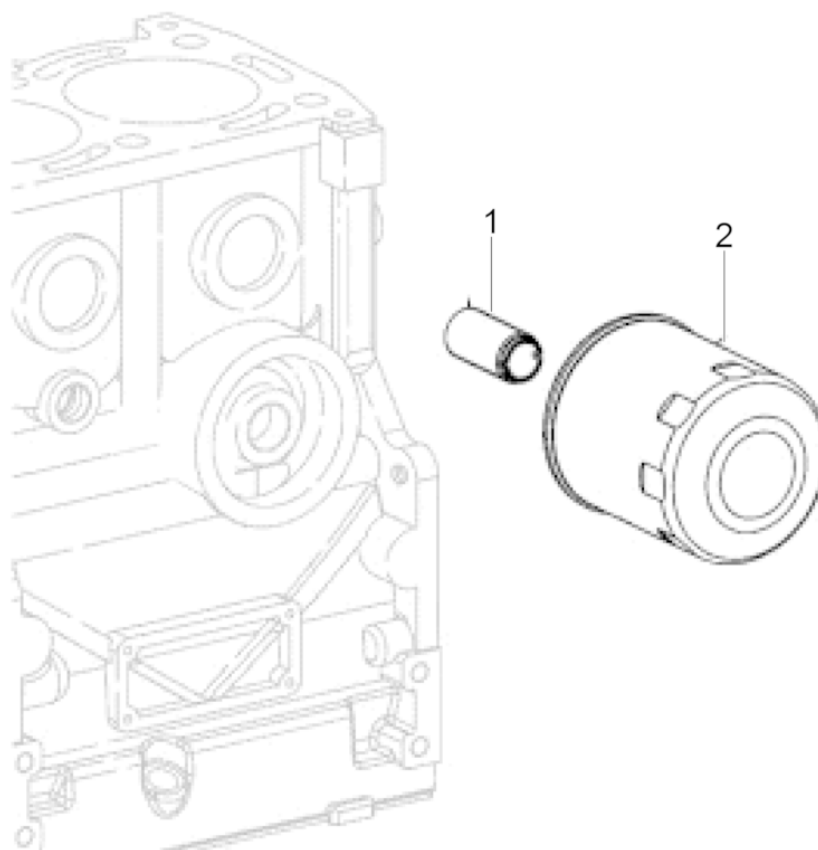

200_5200015979001015

Ref. Pos.	Part No. Artikel Nr.	Qty. St.	Description Beschreibung	Descripción Description	Measuram./Abm.	Norm
					Torque/Drehm.	Sealant Schmierstoff
1	5000159341	1	Fitting-oil filter Ölfilterverschraubung	Unión de filtro de aceite de aceite Raccord de filtre d'huile		
2	5000155736	1	Oil filter Ölfiter	Filtro de aceite Filtre d'huile		

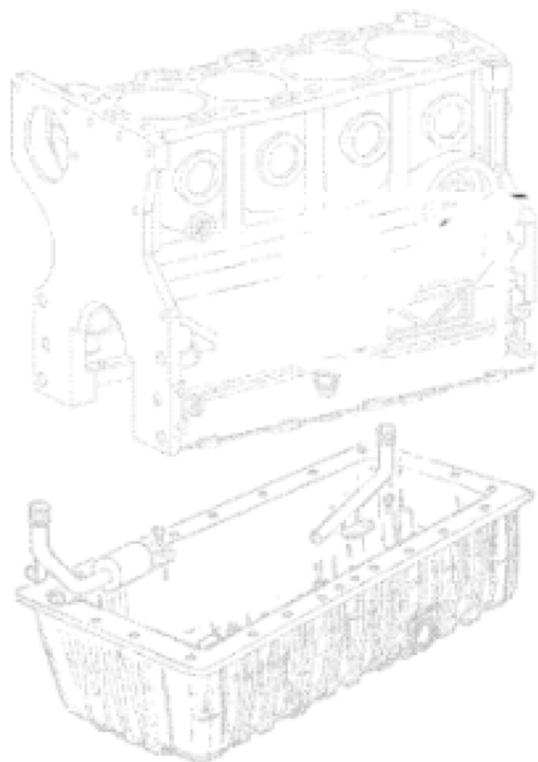

200_5200015979001016

Ref. Pos.	Part No. Artikel Nr.	Qty. St.	Description Beschreibung	Descripción Description	Measurem./Abm.	Norm
					Torque/Drehm.	Sealant Schmierstoff
1	5200009507	1	Oil dipstick Ölpeilstab	Indicador del nivel de aceite Réglette-jauge d'huile		
3	5000155739	1	Protection Schutz	Protecciónel de aceite Protection		
4	5200009508	2	O-Ring O-Ring	Anillo-O Joint torique		

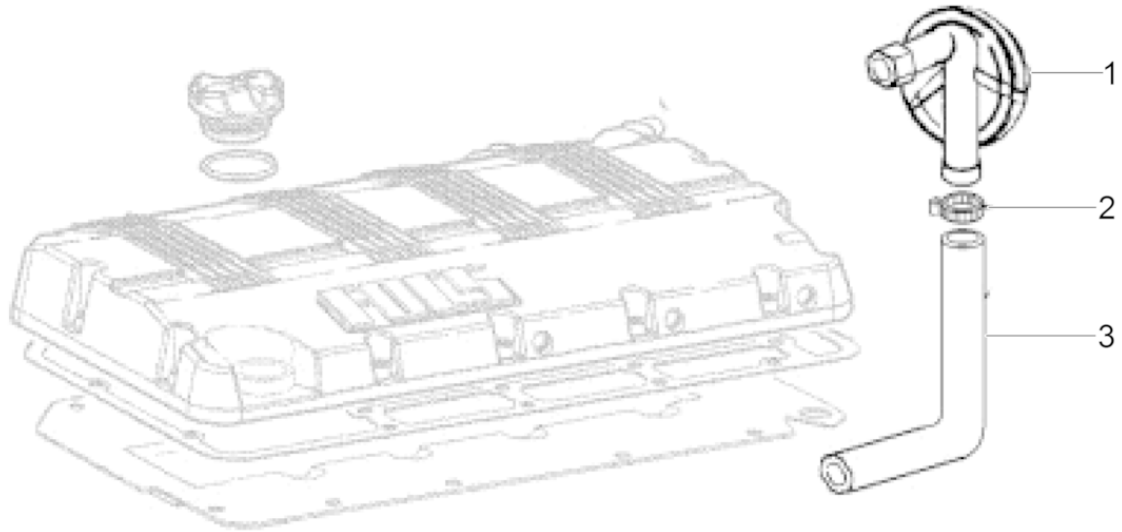

200_5200015979001017

Ref. Pos.	Part No. Artikel Nr.	Qty. St.	Description Beschreibung	Descripción Description	Measurem./Abm.	Norm
					Torque/Drehm.	Sealant Schmierstoff
1	5000155745	1	Pressure valve Überdruckventil	Válvula de sobrepresión Soupape de surpression		
2	5000160201	2	Clamp Schelle	Abrazadera Attache		
3	5000159460	1	Tube Rohr	Tubo Tube		

Speed Governor
Drehzahlregler
Regulador de velocidad
Régulateur de vitesse

RTLx-SC3

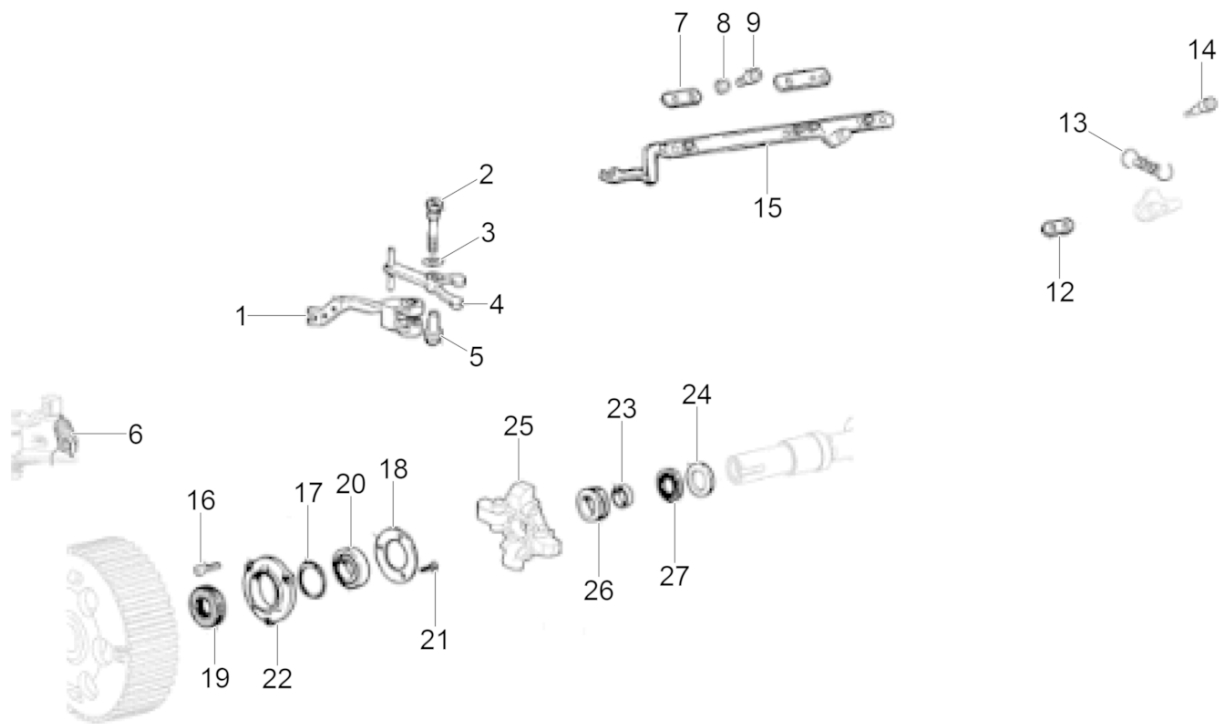

200_5200015979001018

Ref. Pos.	Part No. Artikel Nr.	Qty. St.	Description Beschreibung	Descripción Description	Measurem./Abm.	Norm
					Torque/Drehm.	Sealant Schmierstoff
1	5000159304	1	Governor lever cpl. Reglerhebel kpl.	Palanca de regulador cpl. Levier régulateur cpl.		
2	5000159321	1	Pin Stift	Espiga Goupille		
3	5000159229	1	Oil Seal Öldichtung	Junta de Aceite Joint D'Huile		
5	5000215480	1	Collar Hülse	Collar Douille		
6	5000159314	1	Spring-governor Reglerfeder	Resorte del regulador Ressort régulateur		
7	5200009512	1	Plate Platte	Placa Plaque		
8	5000215520	2	Washer Scheibe	Disco Rondelle		
9	5000159477	4	Screw Schraube	Tornillo Vis		
12	5000160220	1	Plate Platte	Placa Plaque		
13	5000159315	1	Spring Feder	Resorte Ressort		
14	5000211941	3	Screw Schraube	Tornillo Vis		
15	5000159245	1	Linkage Gestänge	Varillaje Tringles		
16	5000159467	3	Cover Deckel	Cubierta Couvercle		
17	5000159239	1	O-Ring O-Ring	Anillo-O Joint torique		
18	5000159324	1	Check disc Anlaufscheibe	Arandela tope Disque		
19	5000159240	1	Lip seal Lippendichtung	Retén labial Joint à lèvres		
20	5000159267	1	Collar Hülse	Collar Douille		
21	5200009514	3	Screw Schraube	Tornillo Vis		
22	5000159265	1	Cover Deckel	Cubierta Couvercle		
23	5000159251	1	Collar Hülse	Collar Douille		
24	5000215517	1	Check disc Anlaufscheibe	Arandela tope Disque		
25	5000155698	1	Speed control module Drehzahlregler	Controlador de velocidad Régulateur de vitesse		
26	5000215506	1	Collar Hülse	Collar Douille		
27	5200009517	1	Bearing Lager	Rodamiento Roulement		

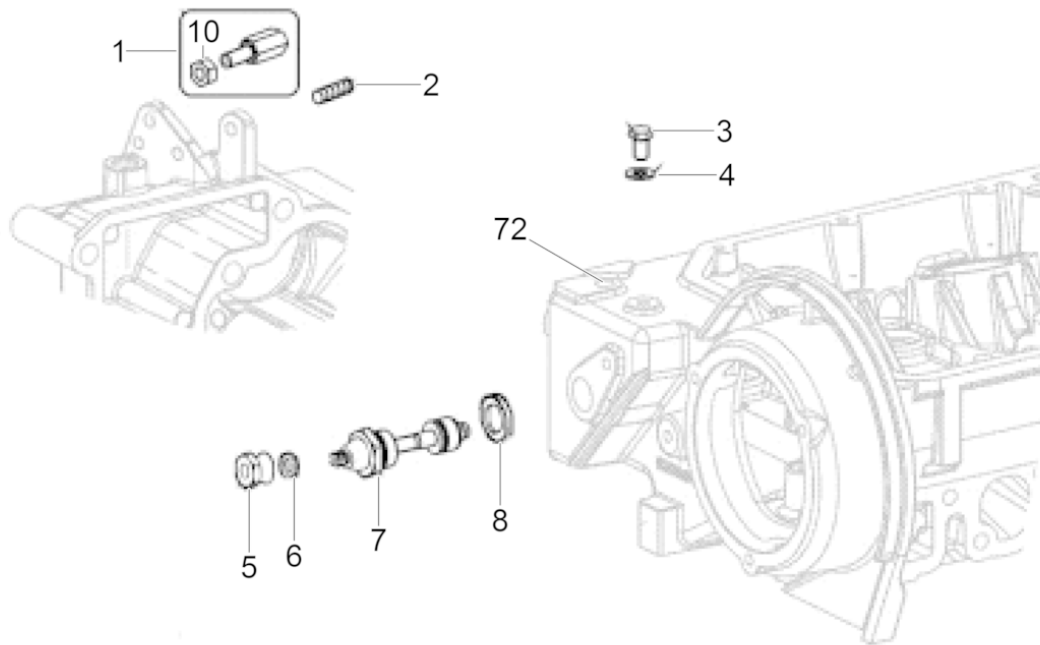

200_5200015979001019

Ref. Pos.	Part No. Artikel Nr.	Qty. St.	Description Beschreibung	Descripción Description	Measurement./Abm.	Norm
					Torque/Drehm.	Sealant Schmierstoff
1	5000159457	1	Screw Schraube	Tornillo Vis		
2	5000215543	1	Screw Schraube	Tornillo Vis		
3	5000084131	2	Screw Schraube	Tornillo Vis		
4	5000083995	2	Washer Scheibe	Arandela Rondelle		
5	5200009518	2	Nut Mutter	Tuerca Écrou		
6	5200009519	1	Washer Scheibe	Arandela Rondelle		
7	5000160389	1	Hose Schlauch	Manguera Tuyau		
8	5000159272	1	Nut Mutter	Tuerca Écrou		
10	5000159272	1	Nut Mutter	Tuerca Écrou		
72	5000215528	1	Plug Stopfen	Tapón Bouchon		

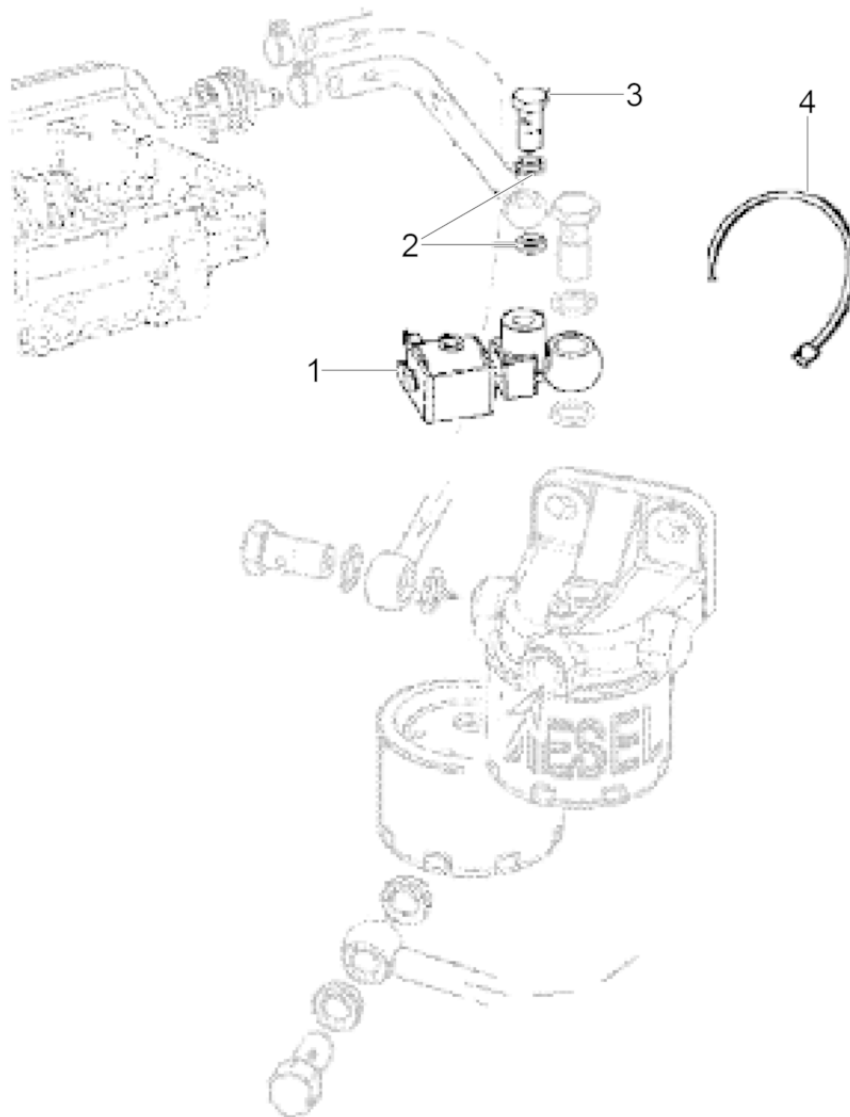

200_5200015979001020

Ref. Pos.	Part No. Artikel Nr.	Qty. St.	Description Beschreibung	Descripción Description	Measurement./Abm.	Norm
					Torque/Drehm.	Sealant Schmierstoff
1	5000155711	1	Fuel valve Kraftstoffventil	Grifo de combustible Robinet de carburant		
2	5000082183	2	Ring seal Dichtring	Anillo sellador Rondelle à étancher		
3	5000082105	1	Screw Schraube	Tornillo Vis		
4	5000215486	1	Collar Manschette	Collar Collet		

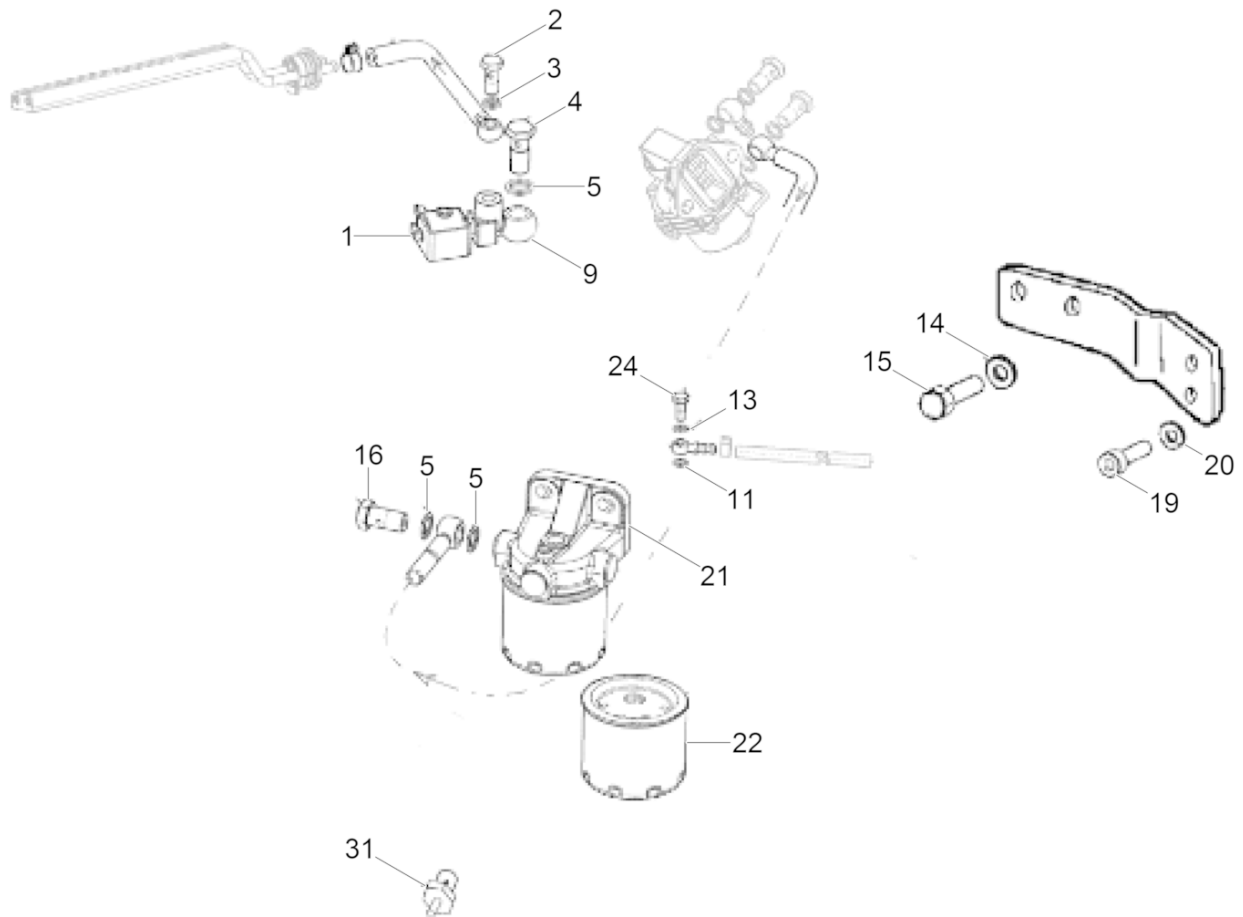

200_5200015979001021

Ref. Pos.	Part No. Artikel Nr.	Qty. St.	Description Beschreibung	Descripción Description	Measurement./Abm.	Norm
					Torque/Drehm.	Sealant Schmierstoff
1	5000155710	1	Jet Düse	Chicler Gicleur		
2	5000082105	1	Screw Schraube	Tornillo Vis		
3	5000082183	1	Ring seal Dichtring	Anillo sellador Rondelle à étancher		
4	5000159250	1	Screw Schraube	Tornillo Vis		
5	5000082185	6	Gasket Dichtung	Junta Joint		
9	5000155711	1	Fuel valve Kraftstoffventil	Grifo de combustible Robinet de carburant		
11	5000203362	1	Nipple Nippel	Boquilla roscada Raccord fileté		
13	5000083995	2	Washer Scheibe	Arandela Rondelle		
14	5000160231	2	Washer Scheibe	Disco Rondelle		
15	5000082100	2	Screw Schraube	Tornillo Vis	M10 x 22	
16	5000082107	1	Banjo bolt Hohlschraube	Perno hueco Boulon creux à filet femelle		
19	5000160363	2	Screw Schraube	Tornillo Vis	M8 x 20	
20	5000160235	2	Washer Scheibe	Arandela Rondelle		
21	5000205200	1	Fuel filter cpl. Kraftstofffilter kpl.	Filtro de combustible compl. Filtre à carburant compl.		
22	5200023966	1	Element Filterpatrone	Elemento Cartouche		
24	5000084231	1	Screw Schraube	Tornillo Vis		
25	5000082183	2	Ring seal Dichtring	Anillo sellador Rondelle à étancher		
31	5000205203	1	Hollow screw Hohlschraubetil	Tornillo huecoora Boulon creux à filet femelle		

Fuel Feed Pump
Förderpumpe
Bomba de Alimentación
Pompe d'Alimentation

RTLx-SC3

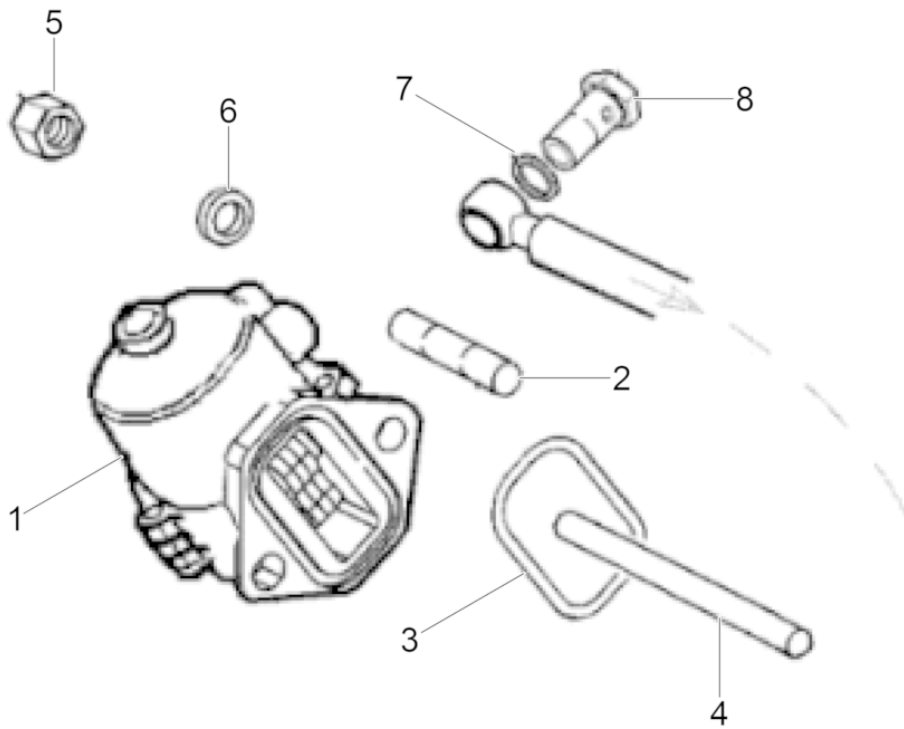

200_5200015979001022

Ref. Pos.	Part No. Artikel Nr.	Qty. St.	Description Beschreibung	Descripción Description	Measurement./Abm.	Norm
					Torque/Drehm.	Sealant Schmierstoff
1	5000155706	1	Fuel Pump Kraftstoffpumpe	Bomba de Combustible Pompe à Essence		
2	5000082266	2	Stud Stiftschraube	Perno prisionero Boulon		
3	5000110759	1	Seal Dichtung	Junta Joint		
4	5000160757	1	Rod Stange	Varillae Tige		
5	5000063700	2	Flange nut Flanschmutter	Tuerca de reborde Ecrou de bride		
6	5000082285	2	Washer Scheibe	Arandela Rondelle		
7	5000082183	4	Ring seal Dichtring	Anillo sellador Rondelle à étancher		
8	5000082105	2	Screw Schraube	Tornillo Vis		

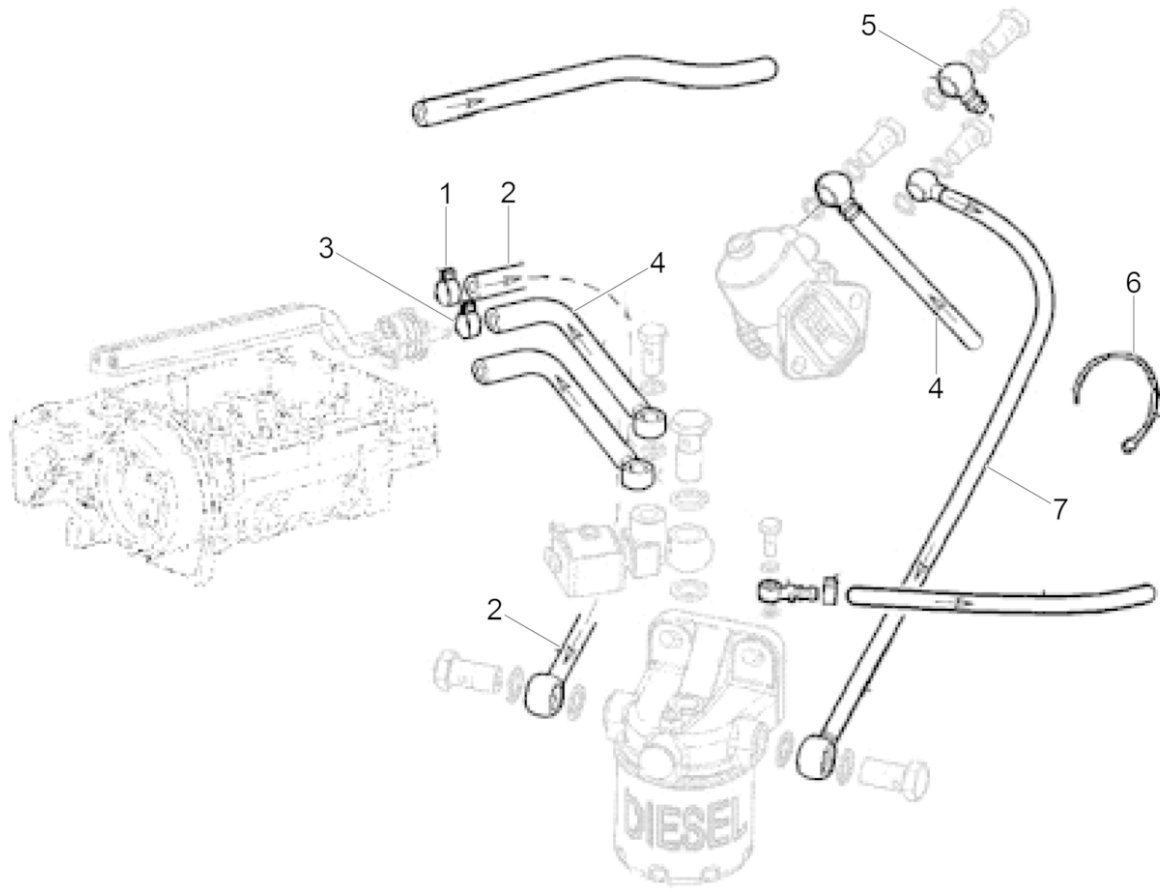

200_5200015979001023

Ref. Pos.	Part No. Artikel Nr.	Qty. St.	Description Beschreibung	Descripción Description	Measurem./Abm.	Norm
					Torque/Drehm.	Sealant Schmierstoff
1	5000082155	1	Clamp Schelle	Abrazadera Collier		
2	5000205202	1	Fuel line Kraftstoffleitung	Manguera de combustible Conduit de carburant	ID 6, OD 12, 738	
3	5000215704	1	Clamp Schelle	Abrazadera Attache		
4	5000210454	1	Fuel hose Kraftstoffleitung	Manguera de combustible Tuyau de carburant	ID 6, OD 12, 680	
5	5000159342	1	Hose fitting Schlauchverschraubung	Unión de manguera Raccord de tuyau		
6	5000215486	3	Collar Manschette	Collar Collet		
7	5000209978	1	Fuel hose Kraftstoffleitung	Manguera de combustible Tuyau de carburant	ID 6, OD 12, 680	

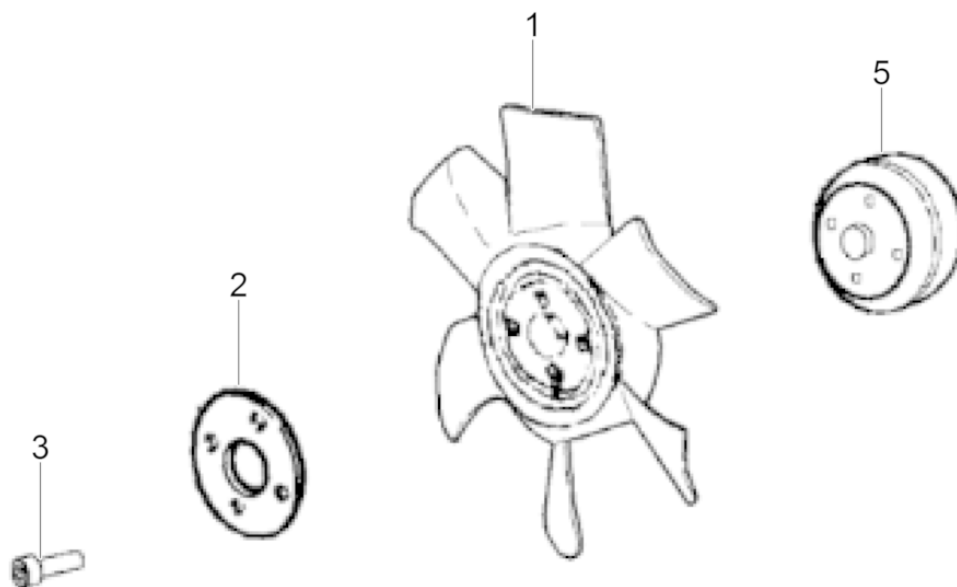

200_5200015979001024

Ref. Pos.	Part No. Artikel Nr.	Qty. St.	Description Beschreibung	Descripción Description	Measurement./Abm.	Norm
					Torque/Drehm.	Sealant Schmierstoff
1	5000159466	1	Fan Gebläserad	Ventilador Ventilateur		
2	5000159323	1	Plate Platte	Placa Plaque		
3	5000207992	4	Screw Schraube	Tornillo Vis		
5	5000215498	1	Flange Flansch	Brida Bride	43,5mm	

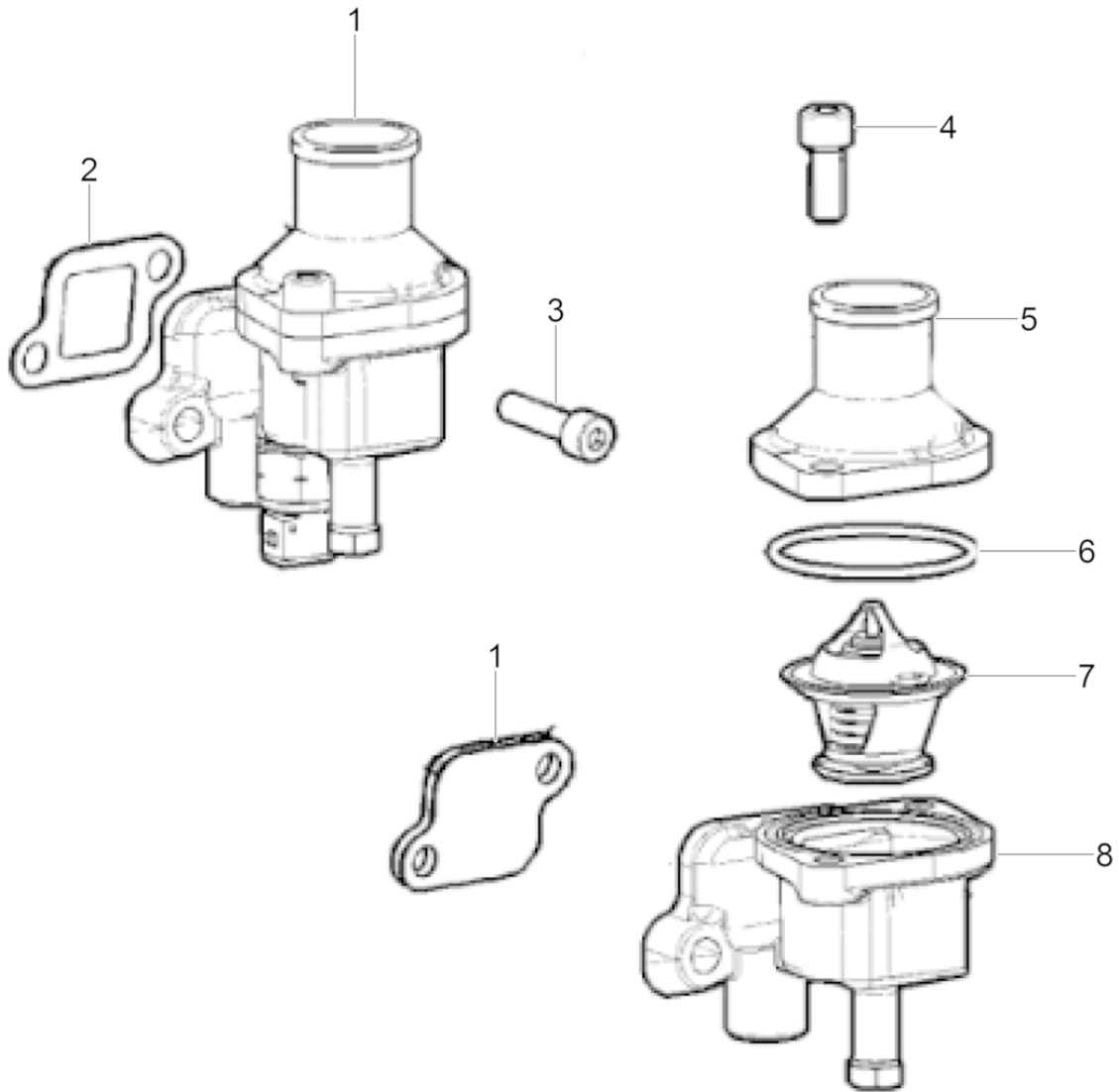

200_5200015979001025

Ref. Pos.	Part No. Artikel Nr.	Qty. St.	Description Beschreibung	Descripción Description	Measurem./Abm.	Norm
					Torque/Drehm.	Sealant Schmierstoff
1	5000160372	1	Housing Gehäuse	Caja Carter		
2	5000207003	1	Gasket Dichtung	Junta Joint		
3	5000159476	2	Screw Schraube	Tornillo Vis		
4	5000084169	2	Screw Schraube	tornillo vis		
5	5000159266	1	Thermostat cover Thermostatdeckel	Tapa del termóstato Couvercle du thermostat		
6	5000159232	1	O-Ring O-Ring	Anillo-O Joint torique		
7	5000207002	1	Valve-thermostat Thermostatventil	Válvula de gobierno termostático Soupape thermostatique		
8	5000211375	1	Housing Gehäuse	Carcasa Enveloppe		
10	5000160387	1	Sensor Sensoreinheit	Unidad de alertaa Appareil d'alerte		
12	5000159299	1	Washer Scheibe	Disco Rondelle		

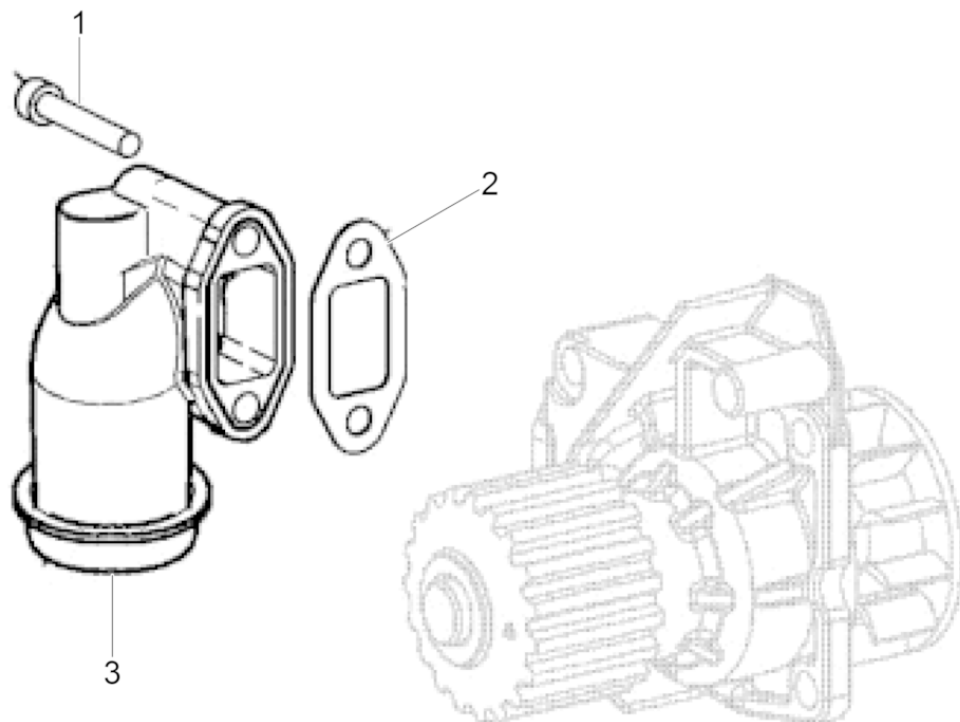

200_5200015979001026

Ref. Pos.	Part No. Artikel Nr.	Qty. St.	Description Beschreibung	Descripción Description	Measurement/Abm.	Norm
					Torque/Drehm.	Sealant Schmierstoff
1	5000160362	2	Screw Schraube	Tornillo Vis		
2	5000159293	1	Gasket Dichtung	Junta Joint		
3	5000155729	1	Hose/water flange Flansch-Schlauch/Wasser	Brida-manguera/agua Colerette-tuyau/eau		

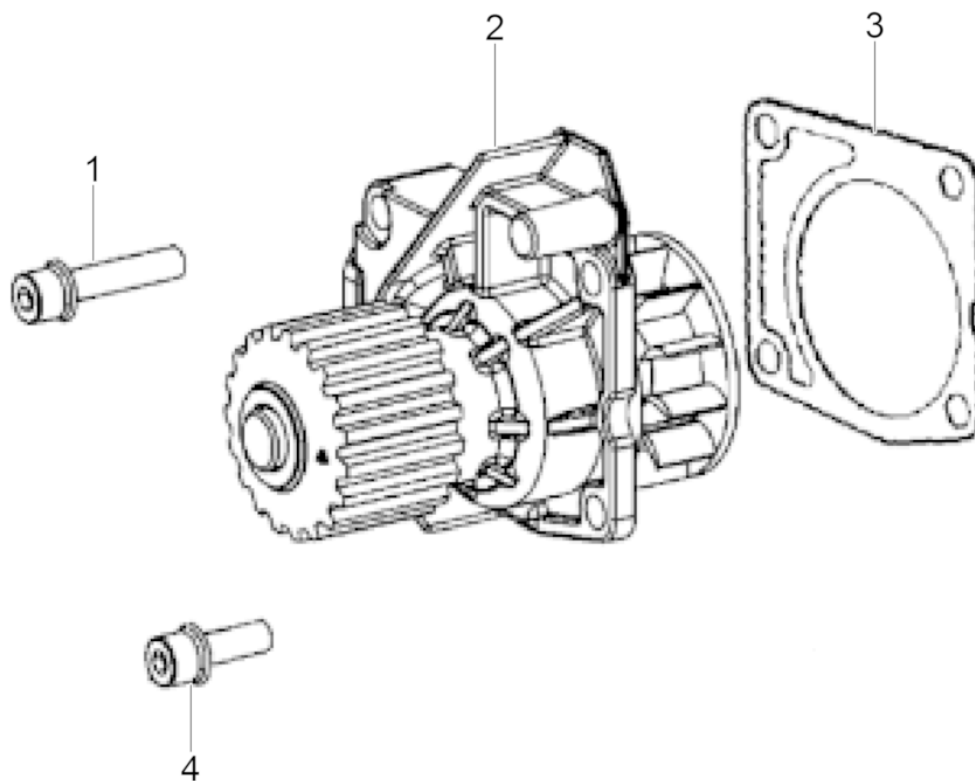

200_5200015979001027

Ref. Pos.	Part No. Artikel Nr.	Qty. St.	Description Beschreibung	Descripción Description	Measurem./Abm.	Norm
					Torque/Drehm.	Sealant Schmierstoff
1	5000209105	2	Hexagonal head cap screw Sechskantschraube	Tornillo hexagonal Vis à tête hexagonale		
2	5000155719	1	Water pump cpl. Wasserpumpe kpl.	Bomba del agua compl. Pompe à eau compl.		
3	5000159298	1	Gasket Dichtung	Junta Joint		
4	5200009523	2	Bolt Innensechskantschraube	Perno Boulon	M8	

Ref. Pos.	Part No. Artikel Nr.	Qty. St.	Description Beschreibung	Descripción Description	Measurem./Abm.	Norm
					Torque/Drehm.	Sealant Schmierstoff
1	5200009524	1	Washer Scheibe	Arandela Rondelle		
2	5200009525	1	Bolt Bolzen	Perno Boulon	M8	
3	5000203352	1	Clamping piece Klemmstück	Pieza de fijación Pièce de serrage		
4	5000160214	1	Lever Hebel	Palanca Levier		
7	5200009526	1	Throttle pin Gasreglerwelle	Pasador de mariposa Goupille des gaz		
8	5000159230	1	Oil Seal Öldichtung	Junta de Aceite Joint D'Huile		
10	5000084170	1	Screw Schraube	Tornillo Vis		
11	5000159476	3	Screw Schraube	Tornillo Vis		
12	5000215504	1	Lever Hebel	Palanca Levier		
13	5000215481	1	Collar Hülse	Collar Douille		
14	5000215508	1	Spring Feder	Resorte Ressort		
15	5000203346	4	Screw Schraube	tornillo vis		
16	5000159272	2	Nut Mutter	Tuerca Écrou		
18	5000206214	2	Screw Schraube	Tornillo Vis	M6 x 30	
20	5000159462	1	Hose Schlauch	Manguera Boyau		
22	5000084232	1	Nut Mutter	Tuerca Ecrou		
23	5000215487	1	Manifold inlet Verteiler, Einlass	Distribuidor, admisión Tubulure, admission		
24	5000160186	1	Intake manifold gasket Ansaugkrümmerdichtung	Junta-distribuidor de admisión Joint-collecteur d'admission		
39	5000084171	1	Screw Schraube	Tornillo Vis		

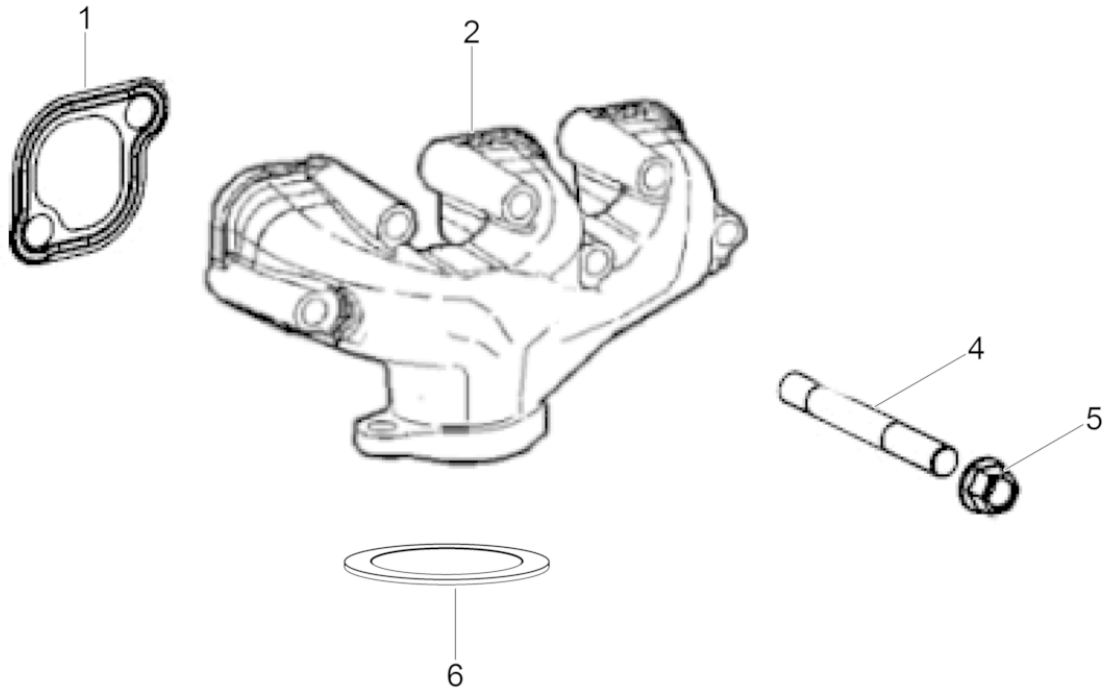

200_5200015979001029

Ref. Pos.	Part No. Artikel Nr.	Qty. St.	Description Beschreibung	Descripción Description	Measurement./Abm.	Norm
					Torque/Drehm.	Sealant Schmierstoff
1	5000159290	3	Gasket Dichtung	Junta de estanqueidad Garniture		
2	5000159263	1	Exhaust manifold Auspuffkrümmer	Distribuidor de escape Collecteur d'échappement		
4	5000082267	6	Stud Gewindebolzen	Perno prisionero Boulon		
5	5000086331	6	Nut Mutter	Tuerca Écrou		
6	5000159295	1	Gasket Dichtung	Junta de estanqueidad Garniture		

**Voltage Regulator
Spannungsregler
Regulador de voltaje
Régulateur de tension**

RTLx-SC3

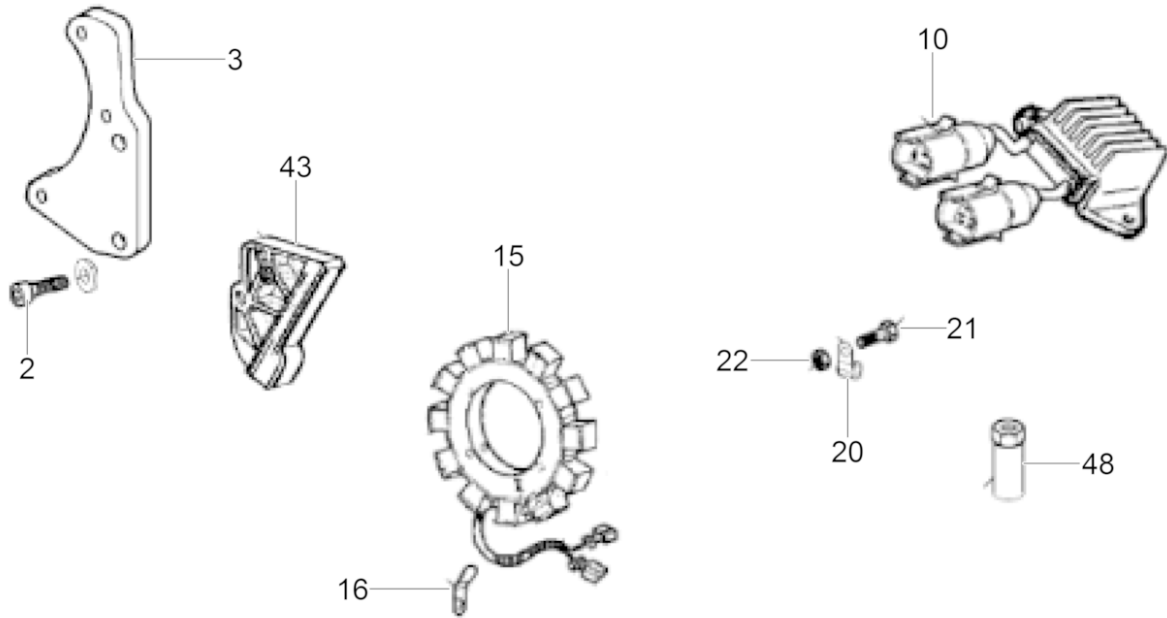

200_5200015979001030

Ref. Pos.	Part No. Artikel Nr.	Qty. St.	Description Beschreibung	Descripción Description	Measurement/Abm.	Norm
					Torque/Drehm.	Sealant Schmierstoff
2	5000159476	2	Screw Schraube	Tornillo Vis		
3	5200023967	1	Alternator support Konsole für Lichtmaschine	Soporte para alternador Support pour alternateur		
10	5200000154	1	Voltage regulator Spannungsregler	Regulador de voltaje Régulateur de tension		
15	5000159446	1	Stator Stator	Estator Stator		
16	5200023968	1	Plate Platte	Placa Plaque		
20	5000209002	1	Clamp Schelle	Abrazadera Collier		
21	5000084156	1	Screw Schraube	Tornillo Vis		
22	5000082140	1	Nut Mutter	Tuerca Écrou		
43	5000159283	1	Flange Flansch	Brida Bride		
48	5200000140	2	Nut Mutter	Tuerca Écrou	M8 25Nm/18ft.lbs	

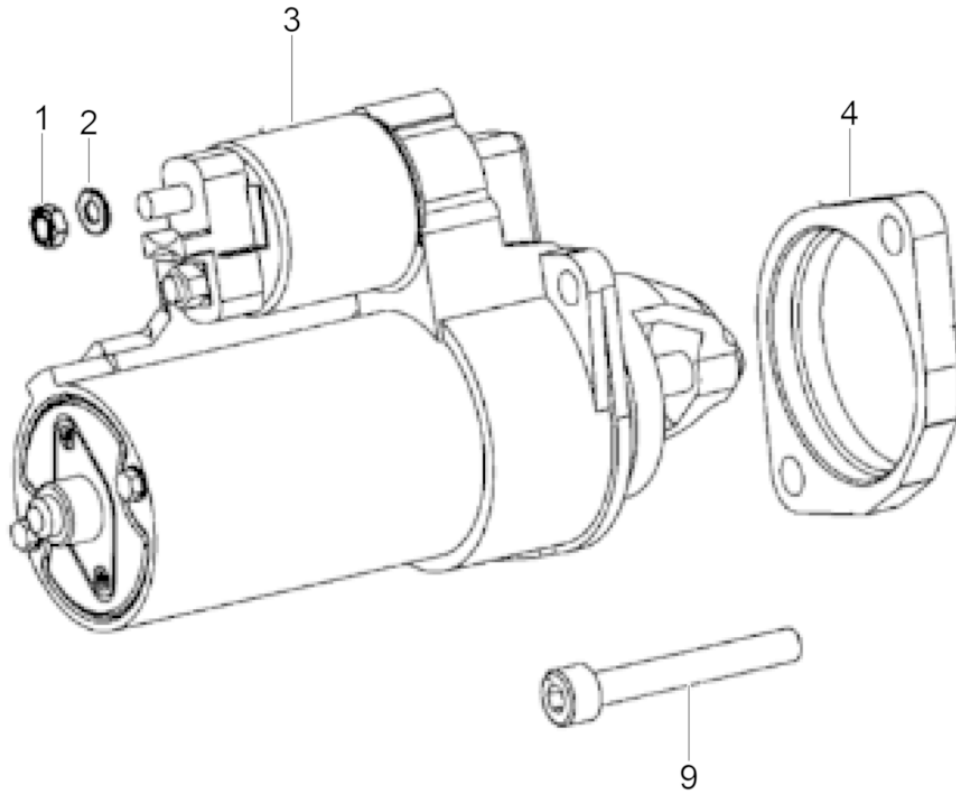

200_5200015979001031

Ref. Pos.	Part No. Artikel Nr.	Qty. St.	Description Beschreibung	Descripción Description	Measurement./Abm.	Norm
					Torque/Drehm.	Sealant Schmierstoff
1	5000215493	1	Hexagon nut Sechskantmutter	Tuerca hexagonal Écrou hexagonal		
2	5000082288	1	Washer Scheibe	Arandela Rondelle		
3	5000160374	1	Starter Motor Anlasser	Motor de Arranque Démarreur		
4	5000206968	1	Flange Flansch	Brida Bride		
9	5000083027	2	Screw Schraube	Tornillo Vis		

Glow Plug
Glühkerze

RTLx-SC3

Tapón luminoso
Bougie de préchauffage

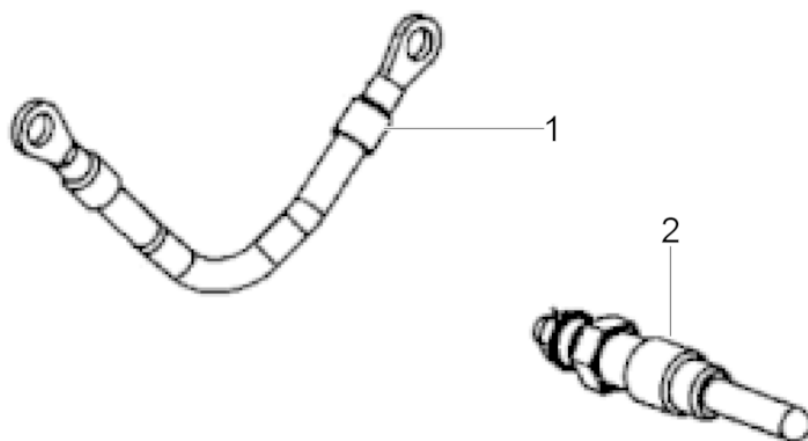

200_5200015979001032

Ref. Pos.	Part No. Artikel Nr.	Qty. St.	Description Beschreibung	Descripción Description	Measurement./Abm.	Norm
					Torque/Drehm.	Sealant Schmierstoff
1	5000159259	2	Cable Kabel	Cable Câble		
2	5000155748	3	Glow plug Glühkerze	Tapón luminoso Bougie de préchauffage		

Hydraulic Pump Adapter
Adapter für Hydraulikpumpe
Adaptador para bomba hidráulica
Raccord pour pompe hydraulique

RTLx-SC3

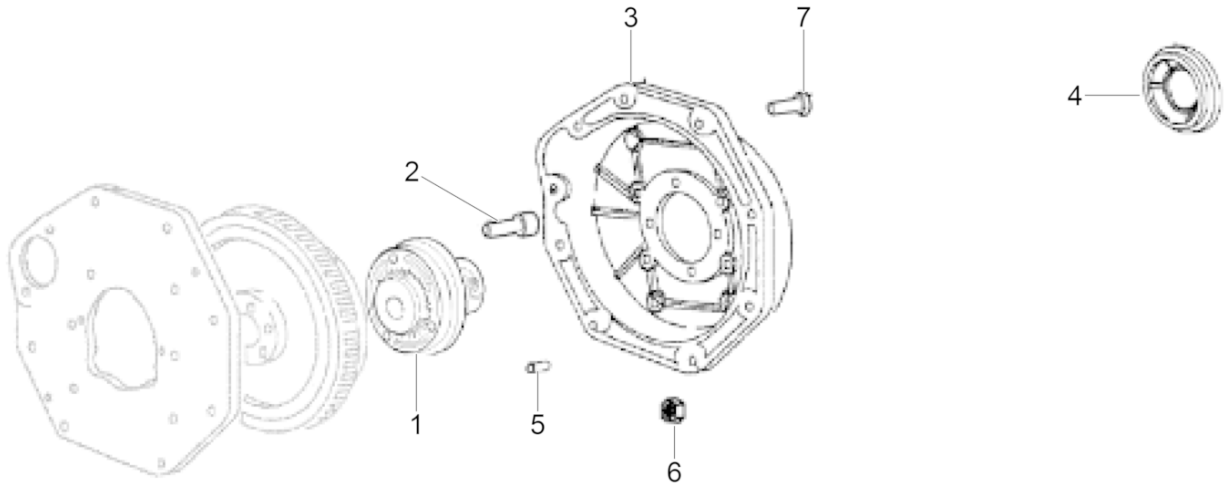

200_5200015979001033

Ref. Pos.	Part No. Artikel Nr.	Qty. St.	Description Beschreibung	Descripción Description	Measurement./Abm.	Norm
					Torque/Drehm.	Sealant Schmierstoff
1	5000161077	1	Coupling Kupplung	Acoplamiento Accouplement		
2	5000084164	3	Screw Schraube	Tornillo Vis		
3	5000161076	1	Housing Gehäuse	Caja Carter		
4	5000161078	1	Spacer Abstandsstück	Espaciador Entretoise		
5	5000161080	2	Dowel pin Paßstift	Espiga Cheville		
6	5000082140	5	Nut Mutter	Tuerca Écrou		
7	5000084123	7	Screw Schraube	Tornillo Vis		

Hydraulic Pump Adapter 2
Adapter für Hydraulikpumpe 2
Adaptador para bomba hidráulica 2
Raccord pour pompe hydraulique

RTLx-SC3

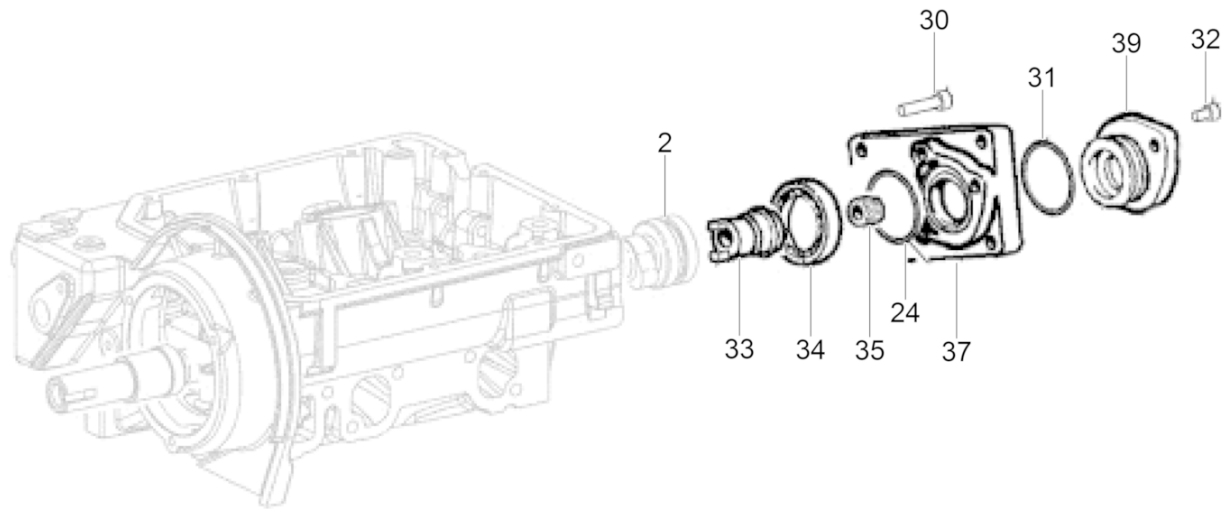

200_5200015979001034

Ref. Pos.	Part No. Artikel Nr.	Qty. St.	Description Beschreibung	Descripción Description	Measurement./Abm.	Norm
					Torque/Drehm.	Sealant Schmierstoff
2	5000160761	1	O-Ring O-Ring	Anillo-O Joint torique	1,42in	
24	5000159234	1	Oil Seal Öldichtung	Junta de Aceite Joint D'Huile		
30	5000160763	3	Bolt Bolzen	Perno Boulon		
31	5000110759	1	Seal Dichtung	Junta Joint		
32	5000160764	2	Bolt Bolzen	Perno Boulon		
33	5000160754	1	Bushing Buchse	Buje Douille		
34	5000160759	1	Ball bearing Kugellager	Rodamiento de bolas Roulement à billes		
35	5000160755	1	Spline coupling Keilnutenkupplung	Acoplamiento de chaveta y ranura Accouplement cannelé		
37	5000160758	1	Flange Flansch	Brida Collerette		
39	5000160756	1	Cover Deckel	Tapa Couvercle		

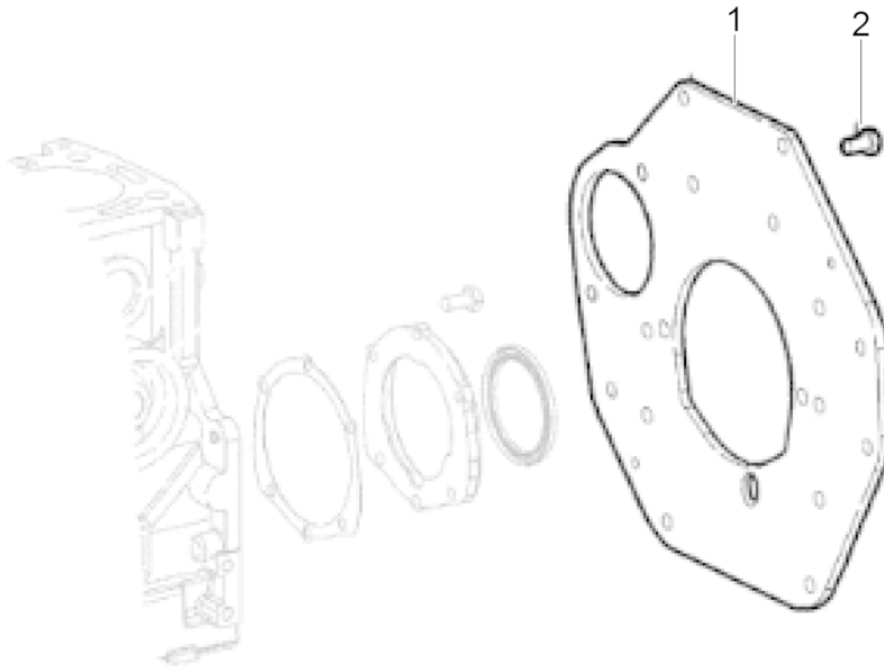

200_5200015979001035

Ref. Pos.	Part No. Artikel Nr.	Qty. St.	Description Beschreibung	Descripción Description	Measuram./Abm.	Norm
					Torque/Drehm.	Sealant Schmierstoff
1	5000159326	1	Plate Platte	Placa Plaque		
2	5000159254	9	Bolt Bolzen	Perno Boulon		
4	5200009534	1	Plug Stopfen	Tapón Bouchon		

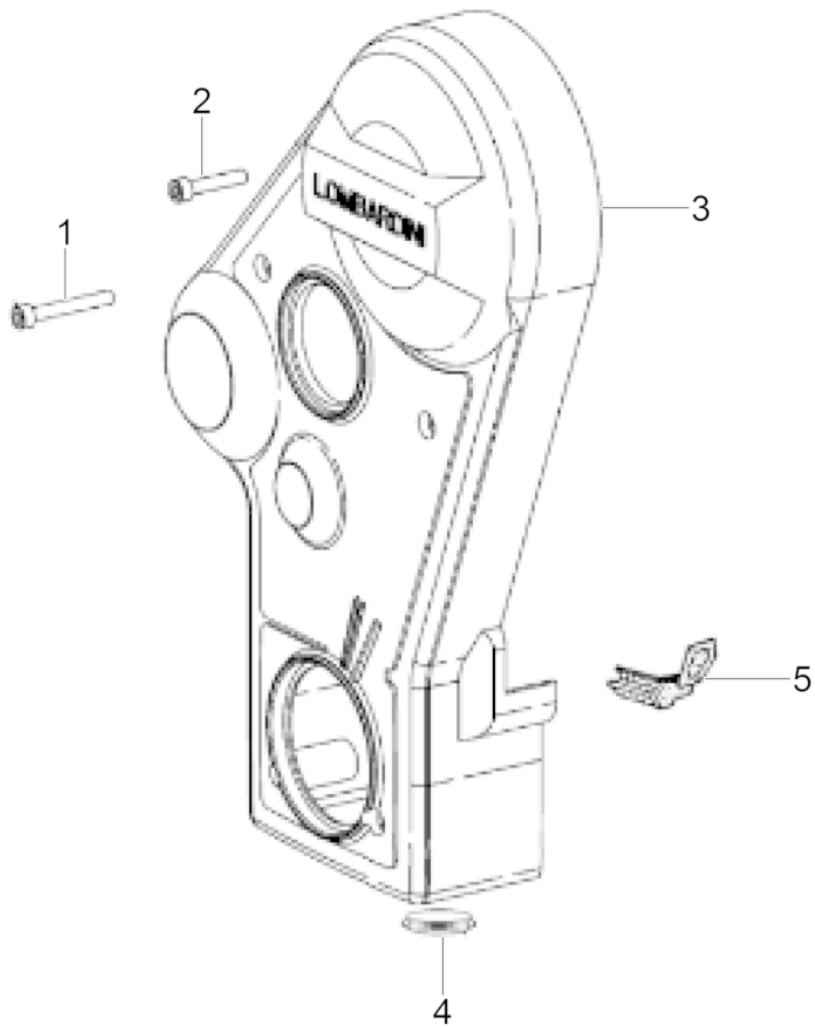

200_5200015979001036

Ref. Pos.	Part No. Artikel Nr.	Qty. St.	Description Beschreibung	Descripción Description	Measurement./Abm.	Norm
					Torque/Drehm.	Sealant Schmierstoff
1	5000159564	1	Screw Schraube	Tornillo Vis		
2	5000159475	4	Screw Schraube	tornillo vis		
3	5000159335	1	Beltguard Riemenschutz	Guardacorrea Protection de courroie		
4	5000159268	1	Plug Stopfen	Enchufe Prise		
5	5000215499	1	Gasket Dichtung	Junta de estanqueidad Garniture		



**WACKER
NEUSON**

**Accessories
Sonderzubehör
Accesorios
Accessoires**

Smooth Drum Kit
Bandagensatz (glatt)
Juego de tambor (plano)
Jeu de tambour (lisse)

RTLx-SC3

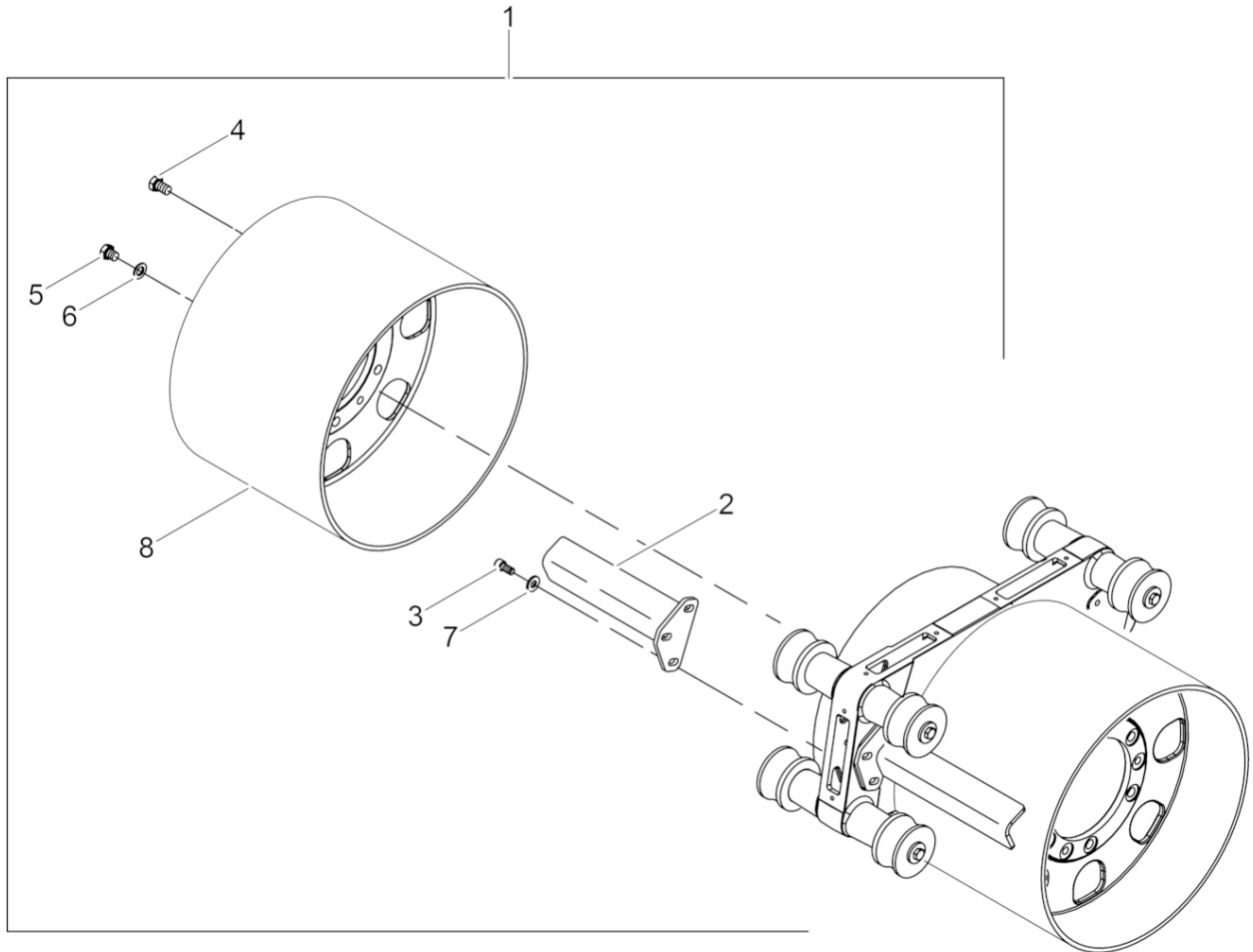

wc_ex0162787001

Ref. Pos.	Part No. Artikel Nr.	Qty. St.	Description Beschreibung	Descripción Description	Measurement/Abm.	Norm
					Torque/Drehm.	Sealant Schmierstoff
1	5000162787	1	Smooth drum kit Bandagensatz	Juego de tambor (plano) Jeu de tambour (lisse)	820mm/32in	
2	5200006892	8	Wide scraper Bandage-Abstreifer	Barra raspadora-ancho Racleur large		
3	5000017087	24	Socket head cap screw Zylinderschraube	Tornillo cilíndrico Vis à tête cylindrique	M12 x 30 86Nm/63ft.lbs	ISO4762 S3
4	5000011542	24	Cheese head screw Zylinderschraube	Tornillo cilíndrico Vis à tête cylindrique	202Nm/149ft.lbs	S3
5	5000031826	12	Screw Schraube	Tornillo Vis	M16 x 16 202Nm/149ft.lbs	S3
6	5000010618	24	Flat washer Scheibe	Arandela Rondelle	16	ISO7090
7	5000031565	24	Lockwasher Spannscheibe	Arandela elástica Rondelle de ressort	12	DIN6796
8	5000171665	4	Smooth drum Bandage (glatt)	Tambor (plano) Tambour (lisse)	820	



**WACKER
NEUSON**