



**WACKER  
NEUSON**

5200019253	111
10.2016	

**Trench Rollers  
Grabenwalzen  
Rodillos para Zanjas  
Rouleaux à pieds d'ameurs**

**RTLx-SC3**

**Parts Book  
Ersatzteile  
Lista de Repuestos  
Liste de Pièces de Rechange**

[www.wackerneuson.com](http://www.wackerneuson.com)



A nameplate listing the Model Number, Item Number, Revision, and Serial Number is attached to each unit. Please record the information found on this plate so it will be available should the nameplate become lost or damaged. When ordering parts or requesting service information, you will always be asked to specify the model, item number, revision number, and serial number of the unit.

Ein Typenschild mit Typ, Artikelnummer, Version und Maschinen-Nummer ist an jedem Gerät angebracht. Die Daten von diesem Schild bitte notieren, damit sie auch bei Verlust oder Beschädigung des Schildes noch vorhanden sind. Der Typ, die Artikel-Nummer, die Versions- Nummer und die Maschinen-Nummer sind bei der Ersatzteilbestellung oder Nachfragen bezüglich Service-Informationen stets erforderlich.

Una placa de identificación con el modelo, número de referencia, nivel de revisión y número de serie ha sido añadida en cada máquina. Favor de anotar los datos en la placa en caso de que la placa de identificación sea destruida o perdida. En todos los pedidos para repuestos necesita siempre el modelo, el número de referencia, el nivel de revisión y el número de serie de la máquina en cuestión.

Une plaque signalétique mentionnant le modèle, le numéro de référence, le niveau de révision et le numéro de série est fixée sur chaque machine. Veuillez noter les informations relevées sur cette plaque de façon à ce qu'elles soient toujours disponibles si la plaque signalétique venait à être perdue ou endommagée. Lorsque vous commandez des pièces détachées ou vous sollicitez des informations après-vente, on vous demandera toujours de préciser le modèle, le numéro de référence, le niveau de révision et le numéro de série de la machine.

***My machine's numbers are / Die Nummern meines Gerätes sind /  
Los números de mi máquina son / Les numéros de ma machine son :***



Part Numbers appearing in boldface type are recommended spare parts. This means that these parts are subject to wear under normal operating conditions and may require periodic service or replacement. It is recommended that these items be stocked to meet the expected service requirements of this model. Actual stocking quantities of these and other parts used in more extensive repairs will depend on the service practices of each customer.

Bei den in den Ersatzteillisten fettgedruckten Nummern handelt es sich um empfohlene Ersatzteile. Dies bedeutet, daß diese Teile bei normalen Anwendungsbedingungen natürlicher Abnutzung ausgesetzt sind und gelegentlich ersetzt oder überarbeitet werden müssen. Es wird geraten, diese Teile auf Lager bereit zu haben, um für Service-Arbeiten an diesem Gerät vorbereitet zu sein. Lagerbestände für diese und andere Teile, welche für ausgiebigere Reparaturarbeiten benötigt werden, können je nach Service-Gewohnheiten der einzelnen Kunden variieren.

Los números de partes en negritas en las Listas Ilustradas de Partes son los repuestos recomendados, ésto quiere decir que estas partes se desgastarán bajo circunstancias de funcionamiento normales y pueden requerir servicio periódico o su reemplazo. Se recomienda que el cliente mantenga un abastecimiento adecuado de estas partes para poder satisfacer la demanda requerida por el servicio a la máquina. La cantidad de repuestos que el cliente necesitará para reparaciones dependerá de la póliza de servicio de cada cliente.

Les numéros de pièces imprimés en caractères gras dans les Listes des Pièces Détachées de ce manuel sont les pièces détachées recommandées par la Wacker. Cela veut dire que ces pièces sont sujettes à usure dans des conditions de travail normales et peuvent nécessiter de l'entretien ou leur remplacement. Nous recommandons que vous disposez d'un stock de ces pièces pour pouvoir satisfaire la demande d'entretien de cette machine. Le client doit décider lui-même de la quantité exacte de pièces de rechange qu'il disposera dans ses stocks.

Engine Compartment Motorkasten Caja de Motor Boîte de Moteur	10
Front Frame Vorderrahmen Bastidor Delantero Châssis Avant	16
Rear Frame Hinterrahmen Bastidor de Atrás Châssis Arrière	22
Articulated Steering Joint Knickgelenk Unión Articulada de Dirección Joint articulé	26
Electric Equipment/Wiring Armaturen/Leitungen Equipo Eléctrico/Cables Équipement Électrique/Câblage	28
Hydraulic Piping Hydraulik-Rohrleitung Tubería Hidráulica Canalisation Hydraulique	32
Hydraulic Piping Hydraulik-Rohrleitung Tubería Hidráulica Canalisation Hydraulique	34
Front Cover Vorderdeckel Tapa delantera Couvercle avant	38
Rear Section/Controls Steuerkontrolle Sección Posterior/Palanca de Mando Partie Arrière/Guidons	40
Rear Cover Hinterdeckel Tapa de atrás Couvercle arrière	44
Drum Drive Bandagenantrieb Accionamiento de Tambor Entraînement de Tambour	46
Drum Drive w/Brake Bandagenantrieb mit Bremse Accionamiento de Tambor con Freno Entraînement de Tambour avec F	50
Front Drum Vorderbandage Tambor Delantero Tambour Avant	56
Rear Drum Hinterbandage Tambor de Atrás Tambour Arrière	58

**Indice**

**Table des matières**

Exciter cpl. Erreger kpl. Excitador compl. Excitatrice compl.	62
Hydraulic Manifold Hydraulikverteiler Distribuidor Hidráulico Tubulure Hydraulique	64
Hydraulic Tank Hydrauliktank Tanque Hidráulico Réservoir Hydraulique	68
Transmitter Module Sender Transmisor Transmetteur	70
Labels Aufkleber Calcomanias Autocollants	72
Engine-Kohler Kohler-Motor Motor Kohler Moteur Kohler	75
Crankshaft Kurbelwelle Cigüeñal Vilebrequin	76
Piston/Connecting Rod Kolben/Pleuel Pistón/Biela Piston/Bielle	78
Flywheel Schwungrad Volante Volant	80
Pulley cpl. Scheibensatz Conjunto Cabrestante Ensemble Poulie	82
Cylinder Head Zylinderkopf Culata Culasse	84
Crankcase Kurbelgehäuse Cárter Carter	86
Cylinder Head Cover Zylinderkopfhaube Tapa del Cilindro Couvercle Supérieur	88
Flywheel Side Support Seite des Schwungrads Soporte del lado del volante m Volant moteur côté soutien	90

Fuel Injection System Kraftstoffeinspritzsystem Sistema de inyección de combustible Système d'Injection De Carbura	92
Camshaft Nockenwelle Arbol de levas Arbre à cames	96
Rocker Arms/Valves Kipphebel/Ventile Balancines/Válvulas Culbuteurs/Soupapes	98
Timing Gear Motorsteuerung Regulador Régulateur	100
Oil Pump Ölpumpe Bomba de Aceite Pompe à Huile	102
Oil Pan Ölwanne Colector de aceite Cuvette-carter à huile	104
Oil Filter Ölfiter Filtro de aceite Filtre d'huile	106
Oil Dipstick Ölpeilstab Indicador del nivel de aceite Réglette-jauge d'huile	108
Breather System Scheibensatz Conjunto Cabrestante Système de reniflard	110
Speed Governor Drehzahlregler Regulador de velocidad Régulateur de vitesse	112
Controls Steuerungen Mandos Commandes	114
Fuel Solenoid Kraftstoffsolenoid Solenoido de combustible Solénoïde à carburant	116
Fuel Filter Kraftstofffilter Filtro de Combustible Filtre à Carburant	118
Fuel Feed Pump Förderpumpe Bomba de Alimentación Pompe d'Alimentation	120

**Indice****Table des matières**

Fuel Pipes Kraftstoffleitungen Tubos de Combustible Conduites de Carburant	122
Fan Gebläserad Ventilador Ventilateur	124
Temperature Sensor Temperatursensoreinheit Unidad de alerta de temperatura Appareil d'alerte de températu	126
Water Manifold Wasser-Verteiler Distribuidor del agua Rampe d'arrosage	128
Water Pump Wasserpumpe Bomba del agua Pompe à eau	130
Air Inlet Manifold Einlassluftleitblech Conducto de aire de entrada Canal d'air d'admission	132
Exhaust Manifold Auspuffkrümmer Distribuidor de escape Collecteur d'échappement	134
Voltage Regulator Spannungsregler Regulador de voltaje Régulateur de tension	136
Starter Motor Anlasser Motor de arranque Démarreur	138
Glow Plug Glühkerze Tapón luminoso Bougie de préchauffage	140
Hydraulic Pump Adapter Adapter für Hydraulikpumpe Adaptador para bomba hidráulica Raccord pour pompe hydraulique	142
Hydraulic Pump Adapter 2 Adapter für Hydraulikpumpe 2 Adaptador para bomba hidráulica 2 Raccord pour pompe hydraulique	144
Backplate Plattenrückwand Placa de atrás Plaque de fond	146
Beltguard Riemenschutz Guardacorrea Protection de courroie	148



Accessories Sonderzubehör Accesorios Accessoires	151
Smooth Drum Kit Bandagensatz (glatt) Juego de tambor (plano) Jeu de tambour (lisse)	152

**Engine Compartment**  
**Motorkasten**  
**Caja de Motor**  
**Boîte de Moteur**

**RTLx-SC3**

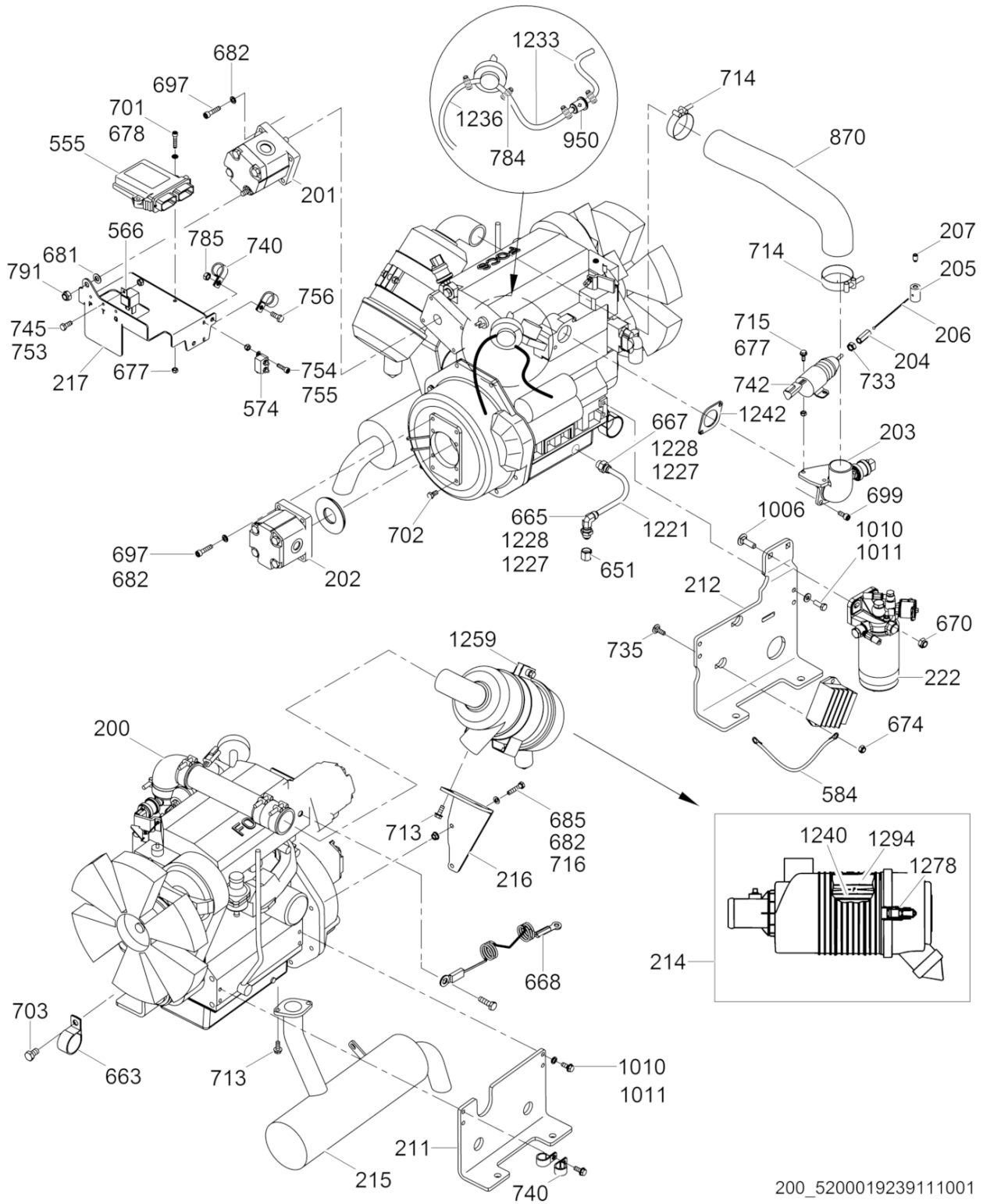

200\_5200019239111001

Ref. Pos.	Part No. Artikel Nr.	Qty. St.	Description Beschreibung	Descripción Description	Measurem./Abm.	Norm
					Torque/Drehm.	Sealant Schmierstoff
200	5200023064	1	Engine-Kohler Kohler-Motor	Motor Kohler Moteur Kohler		
201	0182919	1	Drive pump Antriebspumpe	Bomba de accionamiento Pompe d'entraînement		
202	0182916	1	Exciter pump Erregerpumpe	Bomba del excitador Pompe de l'excitatrice		
203	0119619	1	Adapter Adapter	Adaptador Raccord		
204	0155487	1	Adaptor Adapter	Adaptador Adaptateur		
205	0119695	1	Collar Hülse	Collar Douille		
206	0150022	1	Cable Kabel	Cable Câble		
207	0156315	1	Setscrew Gewindestift	Tornillo Vis	M6 x 10	
211	0115877	1	Bracket Konsole	Soporte Support		
212	0162855	1	Bracket Konsole	Soporte Support		
214	0176114	1	Air cleaner Luftfilter	Filtro del aire Boîtier de filtre complet		
214	0162184	1	Secondary element Sekundärelement	Elemento secundario Cartouche secondaire		
215	0119582	1	Muffler Auspufftopf	Silenciador Pot d'échappement		
216	0154686	1	Air cleaner bracket Luftfilterkonsole	Soporte de filtro del aire Support du filtre à air		
217	0150293	1	Bracket Konsole	Soporte Support		
222	0181844	1	Fuel filter w/water separator Kraftstofffilter mit Wasserabscheider	Filtro de combustible con dispositivo para separar Filtre de carburant avec purge		
555	5200025080	1	Engine control module Motorkontrollmodul	Módulo de mando del motor Module de contrôle de moteur		
555	5200010740	1	Engine control module Motorkontrollmodul	Módulo de mando del motor Module de contrôle de moteur		
566	0085437	3	Relay Relais	Relai Relais		
574	0150961	1	Circuit breaker Unterbrecher	Interruptor de circuito Coupe-circuit	50A 12V	
574	0156190	1	Cover Deckel	Tapa Couvercle		
584	0110557	1	Ground wire Erdungsdraht	Alambre a tierra Fil de masse	12in	
651	0119929	1	Fitting cap Verschraubung, Kappe	Unión, tapa Raccord, Capuchon	No.8	
655	0119906	1	Hose clamp Schlauchselle	Abrazaderas de manguera Agrafe de tuyau	No.20 x 0,81 x 1,75in	

**Engine Compartment**  
**Motorkasten**  
**Caja de Motor**  
**Boîte de Moteur**

**RTLx-SC3**

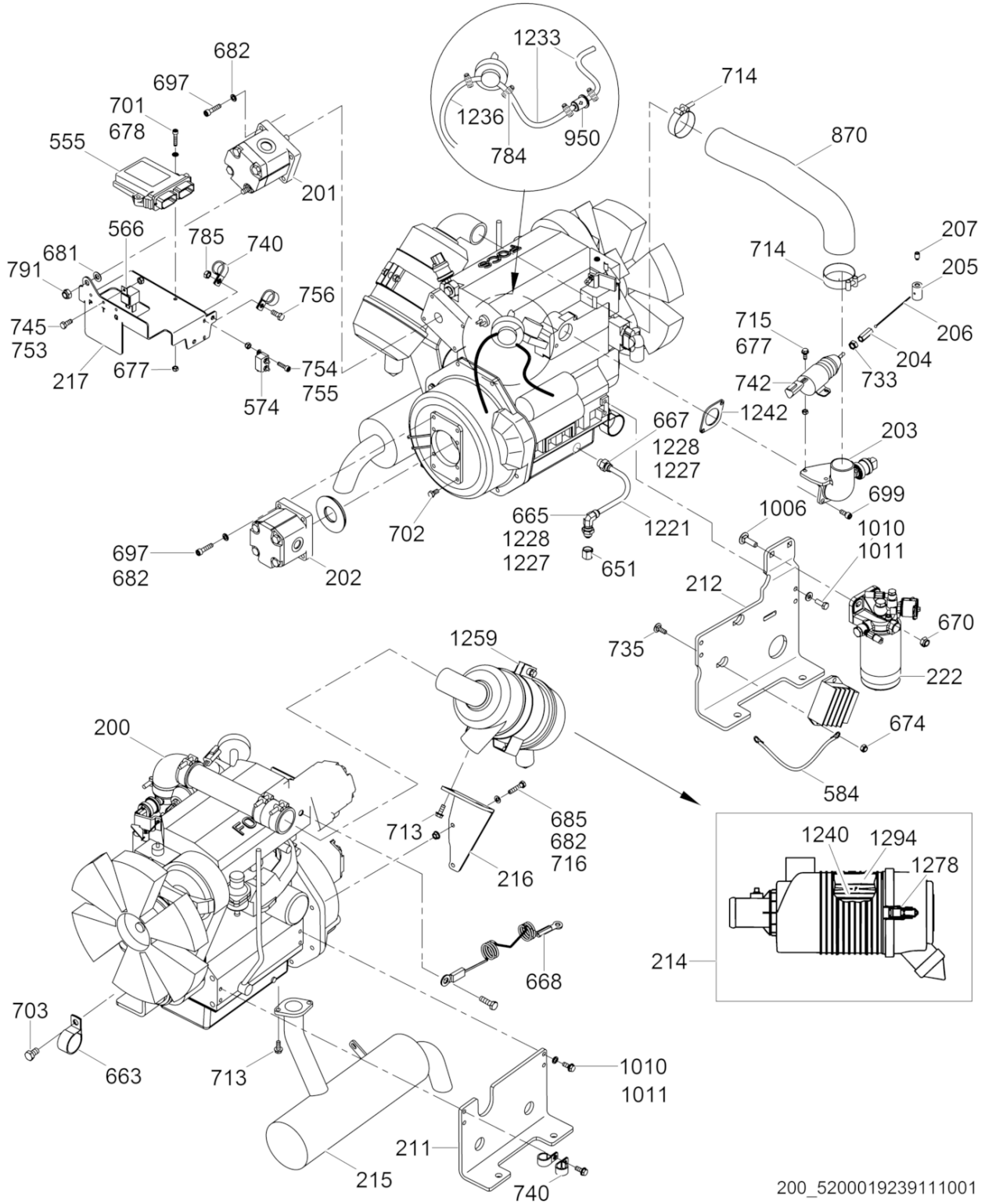

200\_5200019239111001

Ref. Pos.	Part No. Artikel Nr.	Qty. St.	Description Beschreibung	Descripción Description	Measurem./Abm.	Norm
					Torque/Drehm.	Sealant Schmierstoff
663	0119937	1	Hose clamp Schlauchschelle	Abrazaderas de manguera Agrafe de tuyau	44	
665	0119960	2	Fitting Verschraubung	Unión Raccord	No.8	
667	0119962	2	Fitting Verschraubung	Unión Raccord	No.8	
668	0154402	1	Cable Kabel	Cable Câble		
670	0096087	2	Hexagon nut Sechskantmutter	Tuerca hexagonal Écrou hexagonal	M10	DIN6923
674	0010367	2	Hexagon nut Sechskantmutter	Tuerca hexagonal Écrou hexagonal	M8	DIN985
677	0010368	4	Hexagon nut Sechskantmutter	Tuerca hexagonal Écrou hexagonal	M6	DIN985
678	0010624	2	Flat washer Scheibe	Arandela Rondelle		
681	0010621	1	Washer Scheibe	Arandela Rondelle		
682	0010622	10	Flat washer Scheibe	Arandela Rondelle		
685	0011341	2	Hexagonal head cap screw Sechskantschraube	Tornillo hexagonal Vis à tête hexagonale	M8 x 40 25Nm/18ft.lbs	DIN931 S3
690	0011438	2	Hexagonal head cap screw Sechskantschraube	Tornillo hexagonal Vis à tête hexagonale	M10 x 35 49Nm/36ft.lbs	DIN933
697	0011540	8	Cheese head screw Zylinderschraube	Tornillo cilíndrico Vis à tête cylindrique	M8 x 35 41Nm/30ft.lbs	ISO4762 S3
699	0011543	2	Socket head screw Zylinderschraube	Tornillo hueco Vis à six-pans creux	M8 x 20 41Nm/30ft.lbs	ISO4762 S3
701	0011549	2	Cheese head screw Zylinderschraube	Tornillo cilíndrico Vis à tête cylindrique	M6 x 30 17Nm/13ft.lbs	ISO4762
702	0012361	2	Hexagonal head cap screw Sechskantschraube	Tornillo hexagonal Vis à tête hexagonale	M8 x 16 25Nm/18ft.lbs	DIN933 S3
703	0012368	1	Hexagonal head cap screw Sechskantschraube	Tornillo hexagonal Vis à tête hexagonale	M12 x 20 86Nm/63ft.lbs	DIN933 S3
713	0028404	4	Screw Schraube	Tornillo Vis	M8 x 20 34Nm/25ft.lbs	S3
714	0028698	2	Clamp Schlauchschelle	Abrazadera Agrafe	2-3/8in	
715	0028949	2	Screw Schraube	Tornillo Vis	M6 x 16 10Nm/7ft.lbs	
716	0030066	2	Locknut Sechskantmutter	Contratuerca Contre-écrou	M8	
733	0010880	1	Hexagon nut Sechskantmutter	Tuerca hexagonal Écrou hexagonal		
735	0111845	2	Carriage bolt Schloßschraube	Tornillo de carruaje Boulon brut à tête bombée	M8 x 25	
740	0110458	4	Clamp Schelle	Abrazadera Agrafe		
742	0155486	1	Throttle Actuator Gasreglerstellteil	Actuador de Acelerador Dispositif de commande des gaz		

**Engine Compartment  
Motorkasten  
Caja de Motor  
Boîte de Moteur**

**RTLx-SC3**

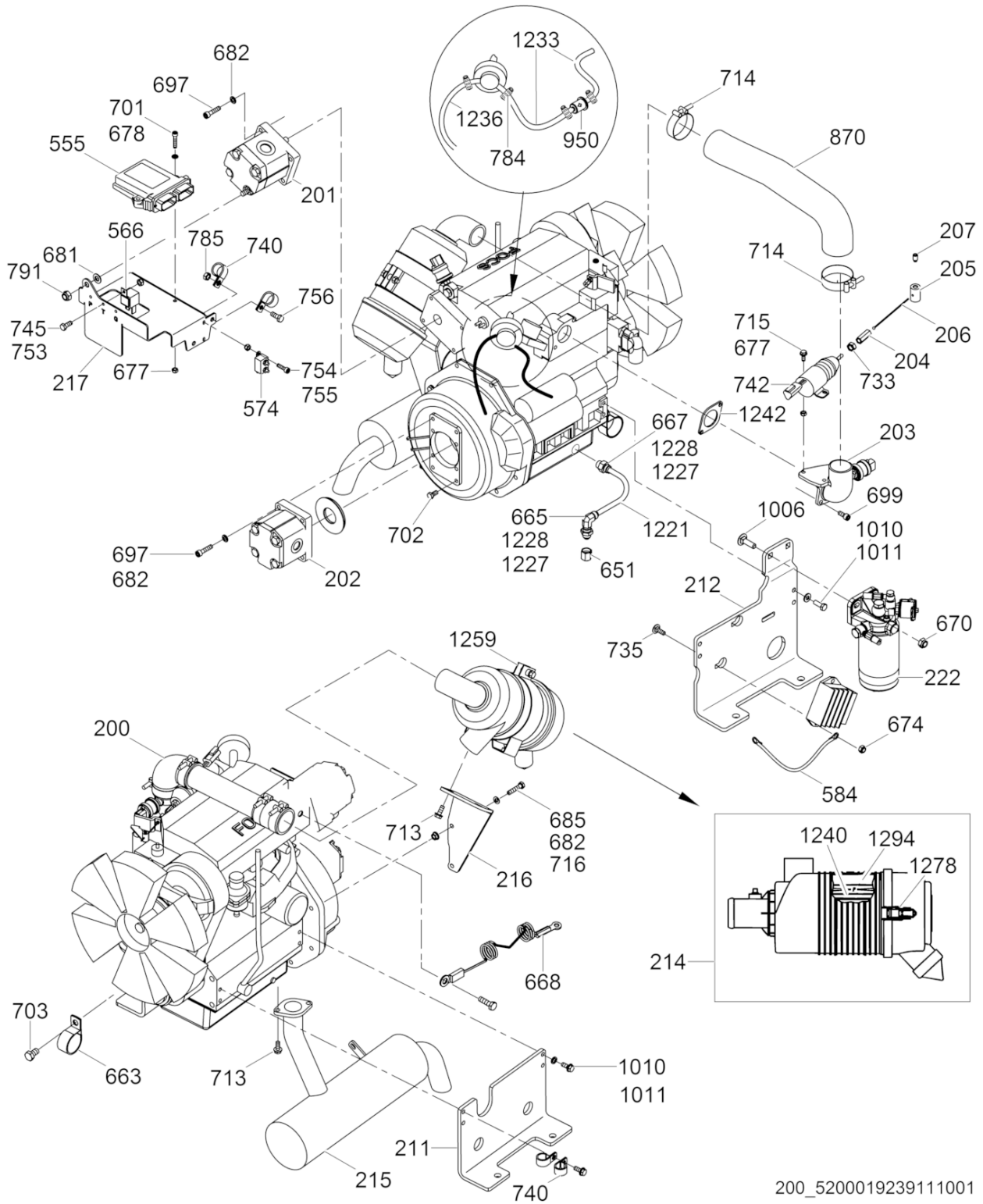

200\_5200019239111001

Ref. Pos.	Part No. Artikel Nr.	Qty. St.	Description Beschreibung	Descripción Description	Measurement/Abm.	Norm
					Torque/Drehm.	Sealant Schmierstoff
745	0011477	3	Hexagonal head cap screw Sechskantschraube	Tornillo hexagonal Vis à tête hexagonale	M5 x 12 6Nm/4ft.lbs	DIN933
753	0010369	3	Hexagon nut Sechskantmutter	Tuerca hexagonal Écrou hexagonal		
754	0011570	2	Cheese head screw Zylinderschraube	Tornillo cilíndrico Vis à tête cylindrique	5Nm/4ft.lbs	
755	0010370	1	Hexagon nut Sechskantmutter	Tuerca hexagonal Écrou hexagonal		
756	0012362	2	Hexagonal head cap screw Sechskantschraube	Tornillo hexagonal Vis à tête hexagonale	25Nm/18ft.lbs	
784	0028707	6	Clamp Schelle	Abrazadera Agrafe	0,21-0,63	
785	0010882	1	Hexagon nut Sechskantmutter	Tuerca hexagonal Écrou hexagonal		
791	0010365	1	Lock nut Sicherungsmutter	Contratuerca Contre-écrou	M10	DIN980
870	0164861	1	Intake manifold hose Einlasskrümmerschlauch	Manguera del distribuidor de admisión Tuyau de collecteur d'admissio		
950	0112497	1	Fuel filter Kraftstofffilter	Filtro de combustible Filtre à carburant		
1006	0162829	2	Carriage bolt Schloßschraube	Tornillo de carruaje Boulon brut à tête bombée	M10 x 35	DIN603
1010	0165460	8	Hexagonal head cap screw Sechskantschraube	Tornillo hexagonal Boulon à tête hexagonale	M8 x 22, 10.9 31Nm/23ft.lbs	S3
1011	0033198	8	Lockwasher Spannscheibe	Arandela elástica Rondelle de ressort	8	DIN6796
1221	0119683	1	Hydraulic hose Hydraulikschlauch	Manguera hidráulica Tuyau hydraulique	380	
1227	0080737	2	O-Ring O-Ring	Anillo-O Joint torique	0,489 x 0,070in	
1228	0080732	2	O-Ring O-Ring	Anillo-O Joint torique	0,644 x 0,087in	
1233	0183205	1	Fuel hose Kraftstoffleitung	Manguera de combustible Tuyau de carburant	3/16 ID x 46,60in	
1236	0159556	1	Fuel hose Kraftstoffleitung	Manguera de combustible Tuyau de carburant	1/4 x 75,6in	
<b>1240</b>	<b>0160171</b>	<b>1</b>	<b>Filter insert Filtereinsatz</b>	<b>Cartucho filtrante Element filtrant</b>		
1242	0159294	1	Gasket Dichtung	Junta de estanqueidad Garniture		
1259	0164069	2	Air filter bracket Luftfilterkonsole	Soporte de filtro del aire Support du filtre à air		
1278	0171456	2	Clamp Klemme	Abrazaderaro de aire Pince		
<b>1294</b>	<b>0162184</b>	<b>1</b>	<b>Secondary element Sekundärelement</b>	<b>Elemento secundario Cartouche secondaire</b>		

**Front Frame**  
**Vorderrahmen**  
**Basitidor Delantero**  
**Châssis Avant**

**RTLx-SC3**

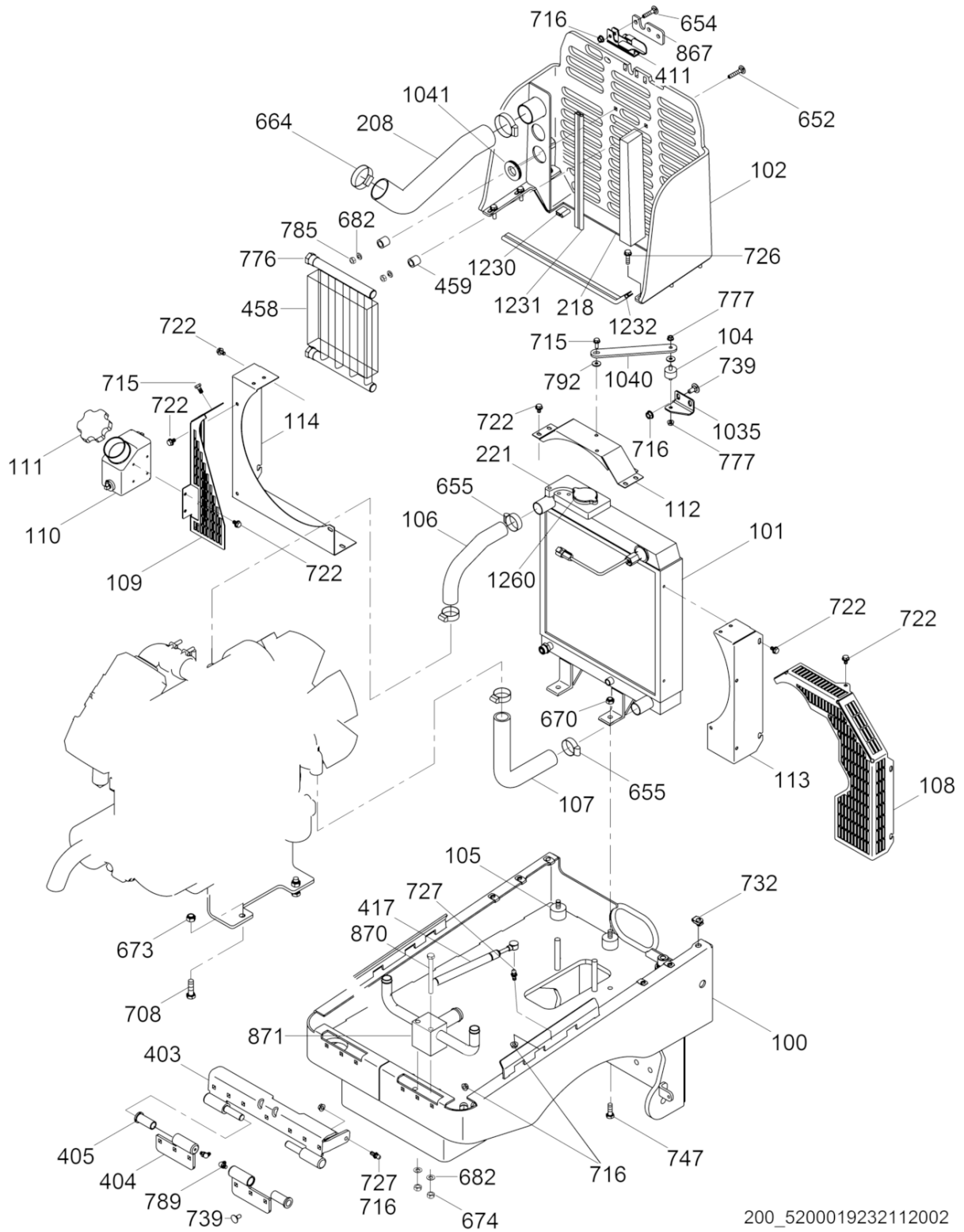

200\_5200019232112002



Ref. Pos.	Part No. Artikel Nr.	Qty. St.	Description Beschreibung	Descripción Description	Measurem./Abm.	Norm
					Torque/Drehm.	Sealant Schmierstoff
100	0116471	1	Front frame Vorderrahmen	Chasis delantero Châssis avant		
101	0154348	1	Radiator Kühler	Radiador Radiateur		
102	0177118	1	Radiator guard Kühlerschutzbügel	Guardarradiador Pare-chocs de radiateur		
104	0150205	1	Shockmount Puffer	Amortiguador Silentbloc	25 x 19-60 Sh	
105	0150206	2	Shockmount Puffer	Amortiguador Silentbloc	38,1 x 25,4-60 Sh	
106	0155119	1	Radiator top hose Oberkühlwasserschlauch	Manguera superior del radiador Tuyau supérieur du radiateur		
107	0155120	1	Radiator bottom hose Unterkühlwasserschlauch	Manguera inferior del radiador Tuyau inférieur du radiateur		
108	0155121	1	Guard Schutz	Protector Protection		
109	0155128	1	Guard Schutz	Protector Protection		
110	0157209	1	Bottle-overflow Überlaufflasche	Botella de rebose Bouteille de trop-plein		
111	0157255	1	Cap Kappe	Tapa Couvercle		
112	0156236	1	Cover Deckel	Tapa Couvercle		
113	0156238	1	Cover Deckel	Tapa Couvercle		
114	0156240	1	Cover Deckel	Tapa Couvercle		
208	0156131	1	Hose Schlauch	Manguera Tuyau		
218	0150225	1	Seal Dichtung	Empaque Joint		
221	0150228	1	Seal Dichtung	Empaque Joint		
403	0119984	1	Pin Stift	Pasador Goupille		
404	0181474	2	Hinge Scharnier	Bisagra Charnière		
405	0164540	2	Bushing spacer Abstandshülse	Espaciador Entretoise		
411	0150098	1	Latch Verriegelung	Aldaba Loquet		
417	0150104	1	Cylinder Zylinder	Cilindro Cylindre		
458	5200024880	1	Radiator Kühler	Radiador Radiateur		
459	0155114	4	Spacer tube Abstandsrohr	Espaciador tubular Pièce d'écartement		
652	0157166	4	Carriage bolt Schloßschraube	Tornillo de carruaje Boulon brut à tête bombée	M8 x 45	

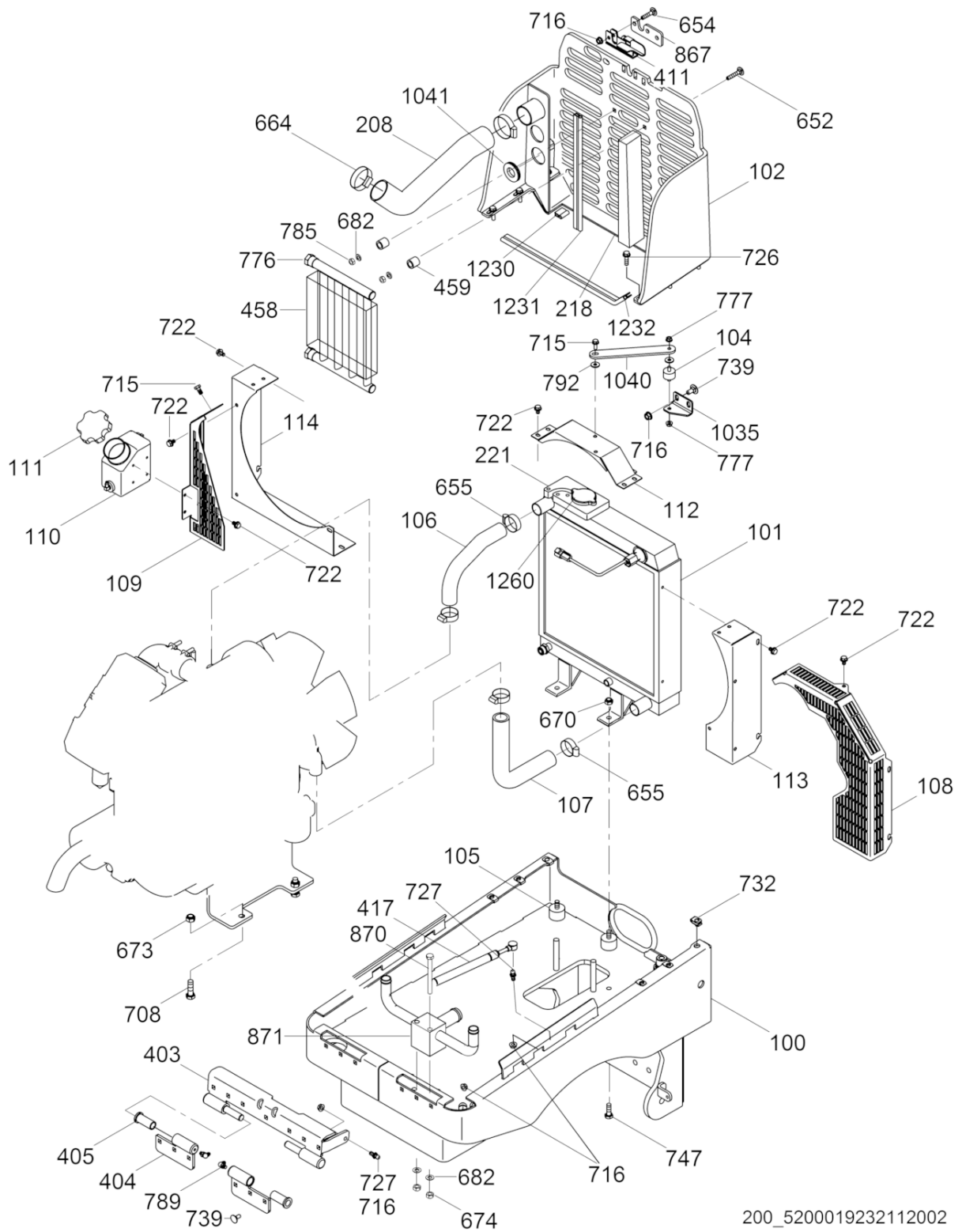

200\_5200019232112002

Ref. Pos.	Part No. Artikel Nr.	Qty. St.	Description Beschreibung	Descripción Description	Measurem./Abm.	Norm
					Torque/Drehm.	Sealant Schmierstoff
654	0119954	3	Carriage bolt Schloßschraube	Tornillo de carruaje Boulon brut à tête bombée	M8 x 40	
655	0119906	4	Hose clamp Schlauchschelle	Abrazaderas de manguera Agrafe de tuyau	No.20 x 0,81 x 1,75in	
664	0119938	2	Hose clamp Schlauchschelle	Abrazaderas de manguera Agrafe de tuyau	No.32	
670	0010365	2	Lock nut Sicherungsmutter	Contratuerca Contre-écrou	M10	DIN980
673	0010366	4	Hexagon nut Sechskantmutter	Tuerca hexagonal Écrou hexagonal	M12	DIN985
674	0011310	2	Hexagonal head cap screw Sechskantschraube	Tornillo hexagonal Vis à tête hexagonale	M8 x 85 25Nm/18ft.lbs	DIN931
682	0010622	12	Flat washer Scheibe	Arandela Rondelle		
708	0016434	4	Screw Schraube	Tornillo Vis	M12 x 40 120Nm/89ft.lbs	
715	0028949	2	Screw Schraube	Tornillo Vis	M6 x 16 10Nm/7ft.lbs	
716	0030066	13	Locknut Sechskantmutter	Contratuerca Contre-écrou	M8 7Nm/5ft.lbs	
722	0073164	14	Hexagonal flange head screw Sechskantflanschschaube	Tornillo hexagonal de brida Vis hexagonale de bride	M6 x 10 10Nm/7ft.lbs	
726	0085957	6	Screw Schraube	Tornillo Vis	M8 x 30 25Nm/18ft.lbs	
727	0155125	2	Stud Gewindebolzen	Perno prisionero Goujon	M8 x 10	
732	0110969	6	Clip nut Klemmutter	Sujetador Agrafe	M8	
739	0155841	8	Carriage bolt Schloßschraube	Tornillo de carruaje Boulon brut à tête bombée	M8 x 20	
747	0012364	2	Hexagonal head cap screw Sechskantschraube	Tornillo hexagonal Vis à tête hexagonale	M10 x 20 49Nm/36ft.lbs	DIN933 S3
776	0081583	2	Straight fitting Verschraubung-gerade	Unión recto Raccord-droit	No.8	
777	0029117	2	Lock nut Sicherungsmutter	Contratuerca Contre-écrou	M6	
785	0010882	2	Hexagon nut Sechskantmutter	Tuerca hexagonal Écrou hexagonal		
789	0114393	2	Grease fitting Schmiernippel	Grasera Graisseur	M6 x 1	
792	0010373	2	Flat washer Scheibe	Arandela Rondelle	6	ISO7093
867	0160294	1	Spacer Abstandsstück	Espaciador Entretoise		
871	0181897	1	Suction manifold Saugverteiler	Distribuidor de succión Collecteur d'aspiration		
1035	0163899	1	Bracket Konsole	Soporte Support		
1040	0163898	1	Radiator bracket Kühlerträger	Soporte del radiador Support de radiateur		

**Front Frame**  
**Vorderrahmen**  
**Basitidor Delantero**  
**Châssis Avant**

**RTLx-SC3**

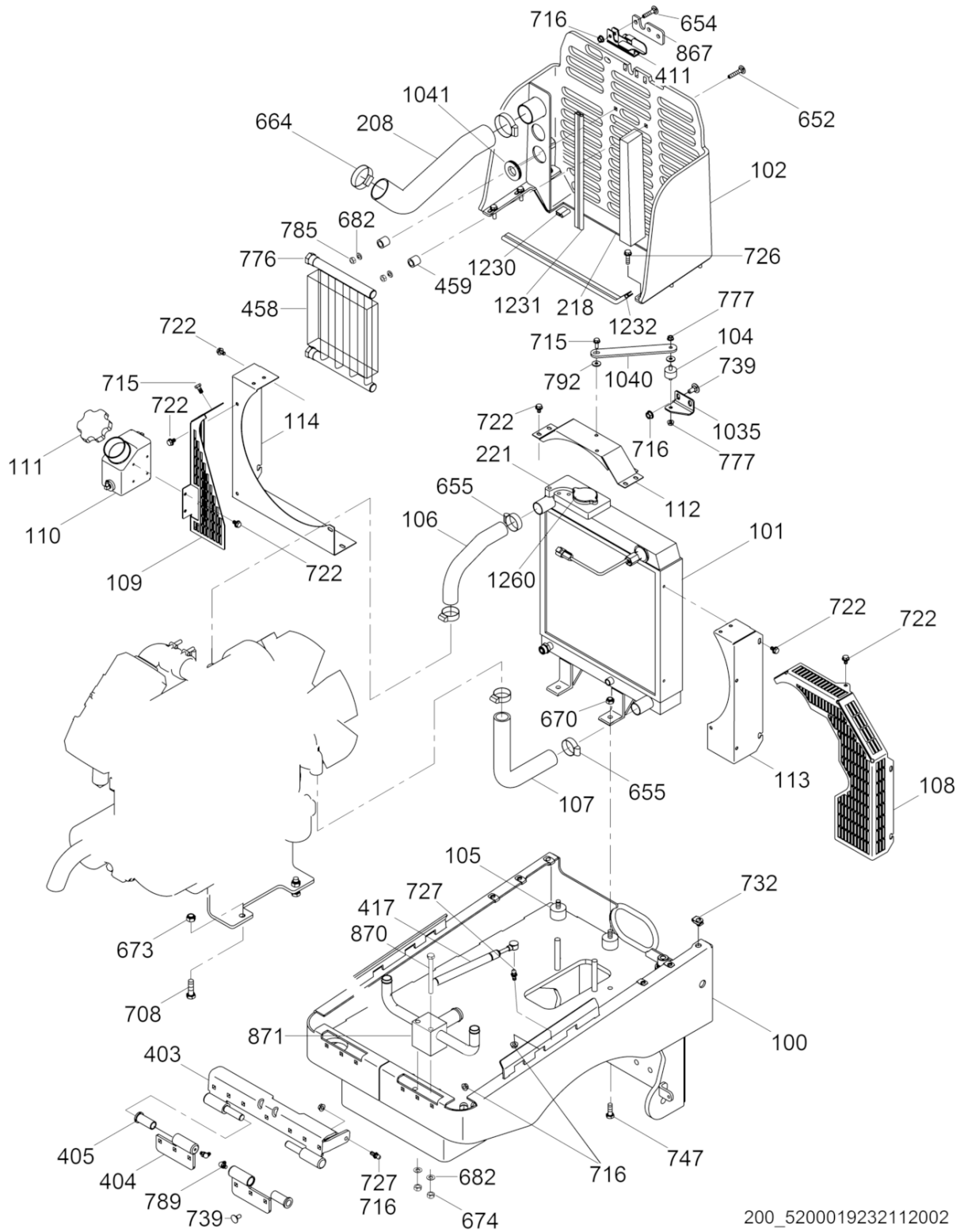

200\_5200019232112002

Ref. Pos.	Part No. Artikel Nr.	Qty. St.	Description Beschreibung	Descripción Description	Measurement./Abm.	Norm
					Torque/Drehm.	Sealant Schmierstoff
1041	0163464	2	Grommet Tülle	Ojal Passe-fil	1 x 1-3/4 x 1/4in	
1230	0159559	1	Seal-trim Profilgummi	Moldura Garniture	1.0in	
1231	0159560	1	Seal-trim Profilgummi	Moldura Garniture	17in	
1232	0159561	1	Seal-trim Profilgummi	Moldura Garniture	1000	
1260	0164350	1	Radiator cap Kühlerverschlußdeckel	Tapa del radiador Couvercle du radiateur		

Rear Frame  
Hinterrahmen  
Bastidor de Atrás  
Châssis Arrière

RTLx-SC3

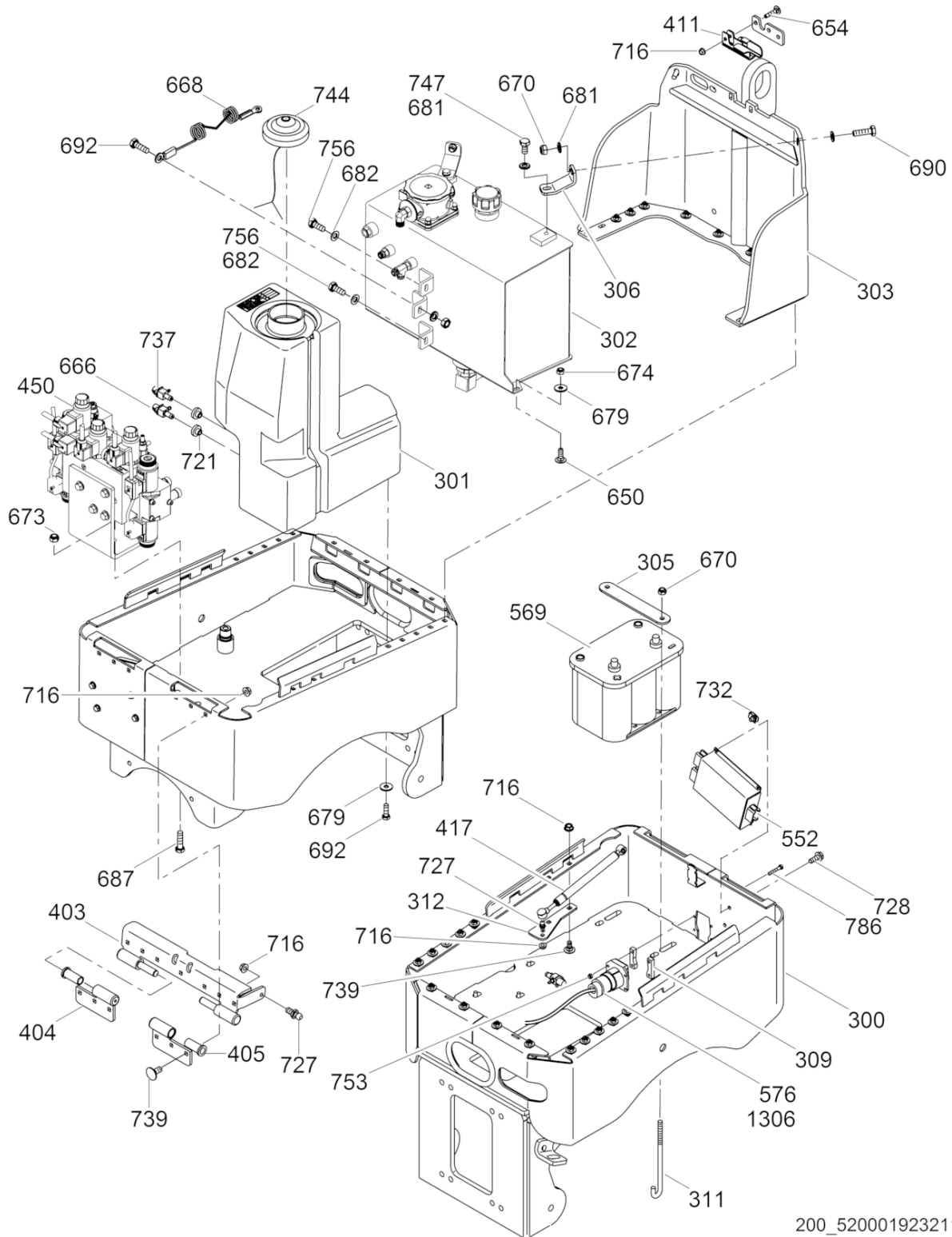

200\_5200019232110003

Ref. Pos.	Part No. Artikel Nr.	Qty. St.	Description Beschreibung	Descripción Description	Measurem./Abm.	Norm
					Torque/Drehm.	Sealant Schmierstoff
300	0117176	1	Rear frame Hinterrahmen	Chasis de atrás Châssis arrière		
301	0153625	1	Fuel tank Kraftstofftank	Depósito de combustible Réservoir de carburant		
302	5200000844	1	Hydraulic tank Hydrauliktank	Tanque hidráulico Réservoir hydraulique		
303	0150089	1	Housing Gehäuse	Caja Carter		
305	0152305	1	Plate Platte	Placa Plaque		
306	0154260	1	Bracket Konsole	Soporte Support		
309	0154751	1	Spacer Abstandsstück	Espaciador Entretoise		
311	0156164	2	Rod Stange	Varilla Tringle		
312	0154712	1	Bracket Konsole	Soporte Support		
403	0119984	1	Pin Stift	Pasador Goupille		
404	0181474	2	Hinge Scharnier	Bisagra Charnière		
405	0164540	2	Bushing spacer Abstandshülse	Espaciador Entretoise		
411	0150098	1	Latch Verriegelung	Aldaba Loquet		
417	0150104	1	Cylinder Zylinder	Cilindro Cylindre		
450	5200025568	1	Hydraulic manifold Hydraulikverteiler	Distribuidor hidráulico Tubulure hydraulique		
552	0165515	1	Decoder module Decodiermodul	Módulo decodificador Module de décodage		
569	0165552	1	Battery Batterie	Batería Batterie	12V	
576	0170950	1	Plug and harness cpl. Stecker und Kabelbaum kpl.	Enchufe y conjunto de cables compl. Fiche et harnais de câbles éle		
650	0157165	14	Carriage bolt Schloßschraube	Tornillo de carruaje Boulon brut à tête bombée	M8 X 25 8,8	
654	0119954	2	Carriage bolt Schloßschraube	Tornillo de carruaje Boulon brut à tête bombée	M8 x 40	
666	0119927	1	Fitting Verschraubung	Unión Raccord	1/4in	
668	0154402	1	Cable Kabel	Cable Câble		
670	0010365	4	Lock nut Sicherungsmutter	Contratuerca Contre-écrou	M10	DIN980
673	0010366	4	Hexagon nut Sechskantmutter	Tuerca hexagonal Écrou hexagonal	M12	DIN985
674	0010367	2	Hexagon nut Sechskantmutter	Tuerca hexagonal Écrou hexagonal	M8	DIN985

Rear Frame  
Hinterrahmen  
Bastidor de Atrás  
Châssis Arrière

RTLx-SC3

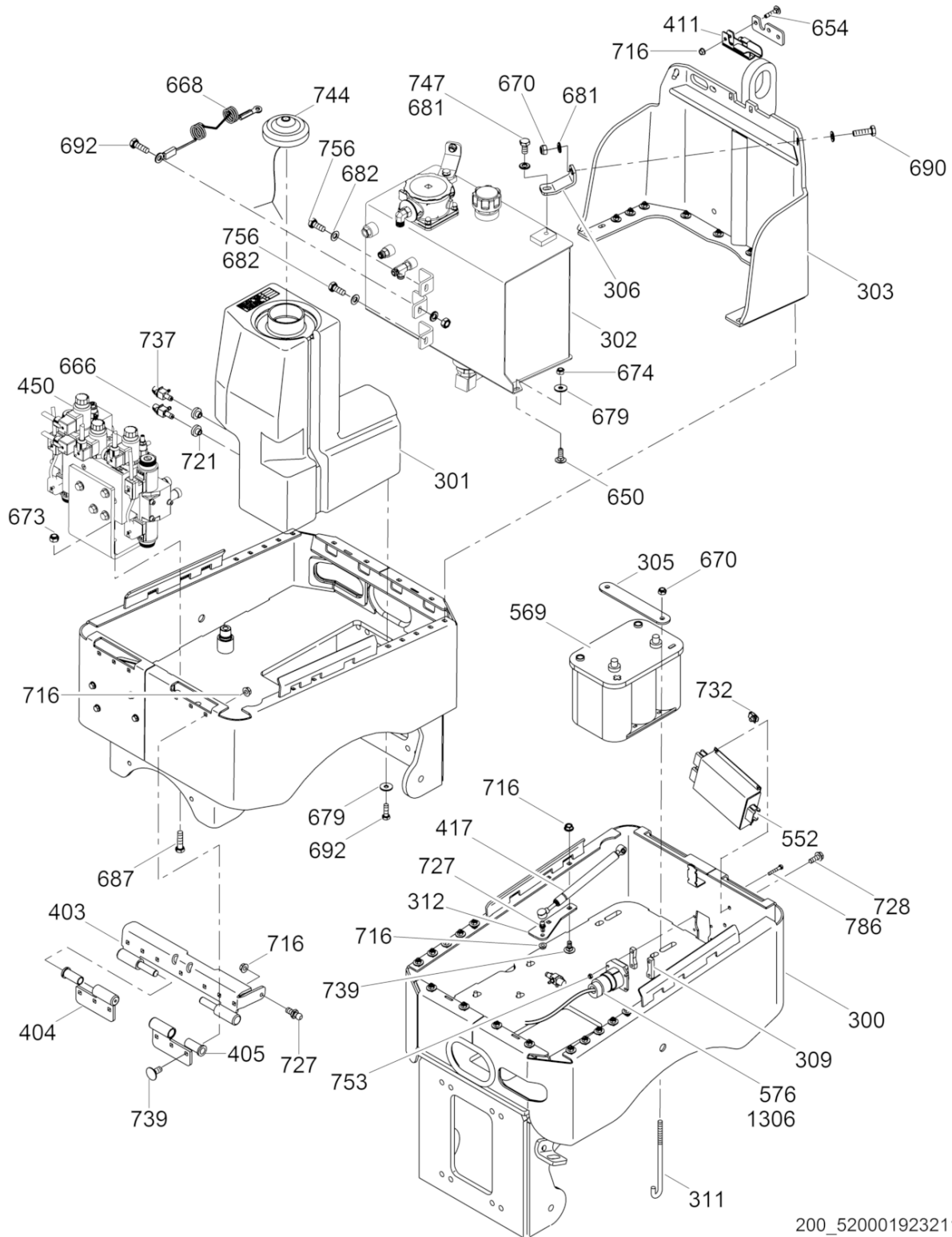

200\_5200019232110003



Ref. Pos.	Part No. Artikel Nr.	Qty. St.	Description Beschreibung	Descripción Description	Measurement./Abm.	Norm
					Torque/Drehm.	Sealant Schmierstoff
679	0160298	6	Flat washer Scheibe	Arandela elástica Rondelle de ressort	B8.4	
681	0010621	6	Washer Scheibe	Arandela Rondelle		
682	0010622	4	Flat washer Scheibe	Arandela Rondelle		
687	0011420	4	Hexagonal head cap screw Sechskantschraube	Tornillo hexagonal Vis à tête hexagonale	M12 x 45 86Nm/63ft.lbs	DIN933
690	0011438	2	Hexagonal head cap screw Sechskantschraube	Tornillo hexagonal Vis à tête hexagonale	M10 x 35 49Nm/36ft.lbs	DIN933
692	0011457	6	Hexagonal head cap screw Sechskantschraube	Tornillo hexagonal Vis à tête hexagonale	M8 x 25 7Nm/5ft.lbs	DIN933 S3
716	0030066	12	Locknut Sechskantmutter	Contratuerca Contre-écrou	M8 7Nm/5ft.lbs	
721	0053577	2	Tank valve bushing Tankbuchse	Buje Douille		
727	0155125	2	Stud Gewindebolzen	Perno prisionero Goujon	M8 x 10	
728	0087023	4	Hexagonal flange head screw Sechskantflanschschrabe	Tornillo hexagonal de brida Vis hexagonale de bride	M8 x 22 25Nm/18ft.lbs	
732	0110969	4	Clip nut Klemmutter	Sujetador Agrafe	M8	
737	0157189	1	Valve Ventil	Válvula Soupape	3/16in	
739	0155841	8	Carriage bolt Schloßschraube	Tornillo de carruaje Boulon brut à tête bombée	M8 x 20	
744	0118640	1	Fuel tank cap Tankverschluß	Tapa del tanque Chapeau de réservoir		
747	0012364	1	Hexagonal head cap screw Sechskantschraube	Tornillo hexagonal Vis à tête hexagonale	M10 x 20 49Nm/36ft.lbs	DIN933 S3
753	0010369	4	Hexagon nut Sechskantmutter	Tuerca hexagonal Écrou hexagonal		
756	0012362	2	Hexagonal head cap screw Sechskantschraube	Tornillo hexagonal Vis à tête hexagonale	7Nm/5ft.lbs	
786	0154898	4	Hexagonal head cap screw Sechskantschraube	Tornillo hexagonal Boulon à tête hexagonale	M5 x 30	
867	0160294	1	Spacer Abstandsstück	Espaciador Entretoise		
1306	0182304	1	Connector Anschlußteil	Conector Connecteur		

**Articulated Steering Joint**  
**Knickgelenk**  
**Unión Articulada de Dirección**  
**Joint articulé**

**RTLx-SC3**



wc\_ex0009025100\_04

Ref. Pos.	Part No. Artikel Nr.	Qty. St.	Description Beschreibung	Descripción Description	Measurem./Abm.	Norm
					Torque/Drehm.	Sealant Schmierstoff
170	0115448	2	Pivot Drehteil	Pivote Pivot		
171	0089323	2	Bracket Konsole	Soporte Support		
173	0119066	2	Pin Stift	Pasador Goupille		
174	0079161	2	Ball bearing Kugellager	Rodamiento de bolas Roulement à billes		
175	2004705	4	Grease fitting Kegelschmiernippel	Grasera Graisseur	AM6	DIN71412
176	0119067	2	Washer Scheibe	Arandela Rondelle		
177	0117018	1	Hydraulic cylinder Hydrozylinder	Cilindro hidráulico Cylindre hydraulique		
178	0017088	2	Lock nut Sicherungsmutter	Contratuercas Contre-écrou	M20	
185	0119629	1	Lock arm Riegel	Seguro Verrou		
680	0010618	1	Flat washer Scheibe	Arandela Rondelle	16	ISO7090
686	0011382	1	Hexagonal head cap screw Sechskantschraube	Tornillo hexagonal Vis à tête hexagonale	M16 x 90 210Nm/155ft.lbs	DIN931
701	0011549	1	Cheese head screw Zylinderschraube	Tornillo cilíndrico Vis à tête cylindrique	M6 x 30 17Nm/13ft.lbs	ISO4762
703	0012368	2	Hexagonal head cap screw Sechskantschraube	Tornillo hexagonal Vis à tête hexagonale	M12 x 20 86Nm/63ft.lbs	DIN933 S3
705	0011382	1	Hexagonal head cap screw Sechskantschraube	Tornillo hexagonal Vis à tête hexagonale	M16 x 90 210Nm/155ft.lbs	DIN931
706	0013618	2	Flat washer Scheibe	Arandela Rondelle	13	DIN7349
708	0016434	16	Screw Schraube	Tornillo Vis	M12 x 40 86Nm/63ft.lbs	
715	0028949	1	Screw Schraube	Tornillo Vis	M6 x 16 10Nm/7ft.lbs	
717	0031121	2	Washer Scheibe	Arandela Rondelle		
734	0111536	1	Latch Verriegelung	Aldaba Loquet		
741	2005276	1	Cotter pin Splint	Clavija hendida Goupille fendue	No.3-9/16in	
1274	0165049	1	Hose guard Schlauchschutz	Protector de manguera Protecteur		

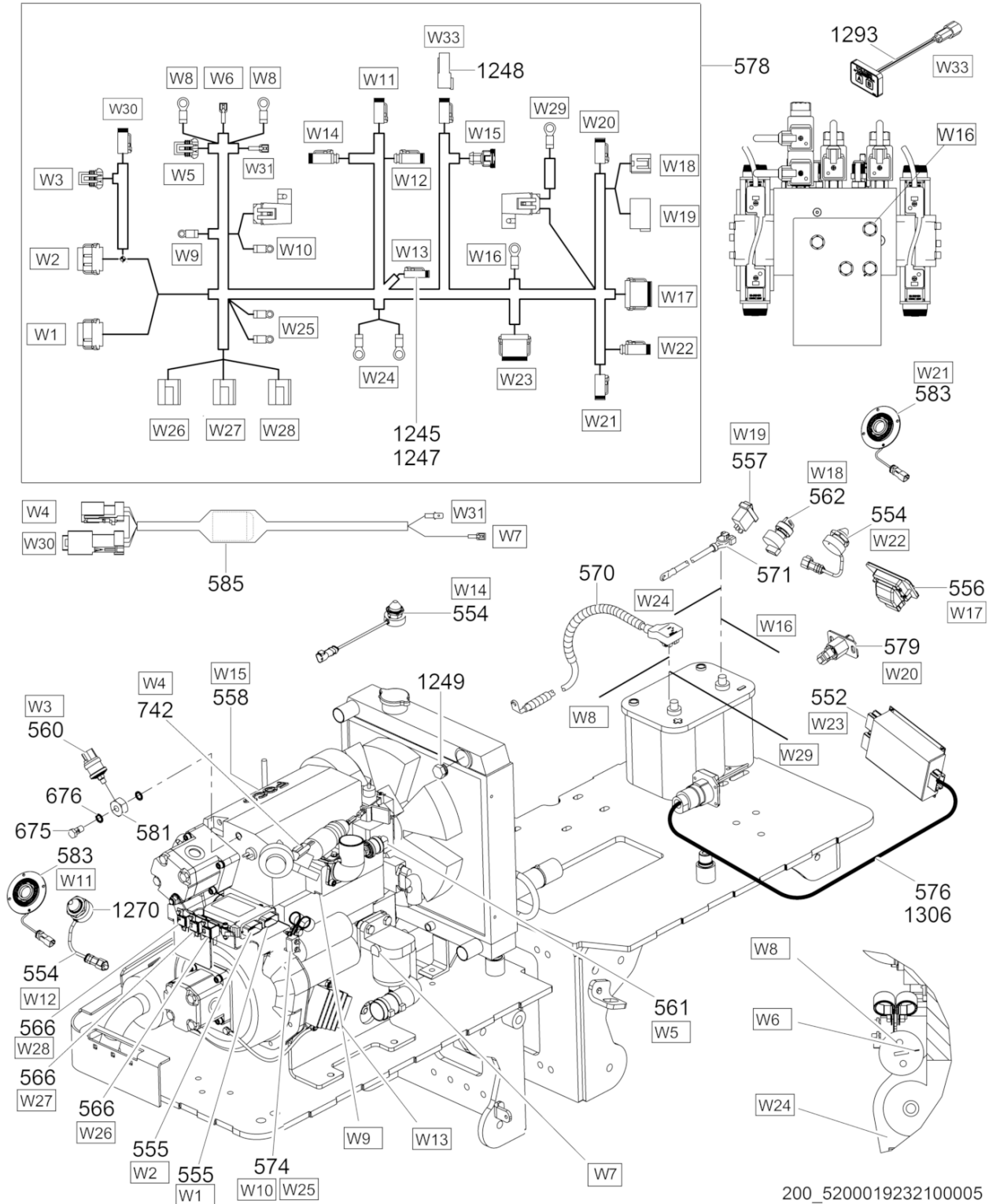

200\_520001923210005

Ref. Pos.	Part No. Artikel Nr.	Qty. St.	Description Beschreibung	Descripción Description	Measur./Abm.	Norm
					Torque/Drehm.	Sealant Schmierstoff
552	0165515	1	Decoder module Decodiermodul	Módulo decodificador Module de décodage		
554	0170949	3	Infrared sensor Empfängerauge	Receptor de rayos Oeil récepteur		
555	5200010740	1	Engine control module Motorkontrollmodul	Módulo de mando del motor Module de contrôle de moteur		
556	0150109	1	Module Modul	Módulo Module		
557	0150110	1	Switch Schalter	Interruptor Interrupteur		
558	0160387	1	Sensor Sensoreinheit	Unidad de alerta Appareil d'alerte		
560	0150113	1	Oil pressure switch Öldruckschalter	Interruptor de presión de aceite Interrupteur à pression d'huile		
561	0150114	1	Vacuum switch Vakuumschalter	Interruptor Interrupteur à vide		
562	0150115	1	Ignition switch Zündschalter	Interruptor de encendido Interrupteur d'ignition		
566	0085437	3	Relay Relais	Relai Relais		
570	0119292	1	Positive battery cable Plusbatteriekabel	Cable positivo de batería Câble positif de batterie		
571	0119293	1	Negative battery cable Minusbatteriekabel	Cable negativo de batería Câble négatif de batterie		
574	0150961	1	Circuit breaker Unterbrecher	Interruptor de circuito Coupe-circuit	50A 12V	
576	0170950	1	Plug and harness cpl. Stecker und Kabelbaum kpl.	Enchufe y conjunto de cables compl. Fiche et harnais de câbles éle		
578	5200020490	1	Wiring harness Kabelbaum	Conjunto de cables Harnais de câbles électriques		
579	0154405	1	Charge port module Ladungsanschlussmodul	Módulo de toma de carga Module de prise de charge		
581	0150291	1	Adapter Adapter	Adaptador Raccord		
583	0154403	2	Light ring module Lichtringmodul	Módulo de anillo de luz Module de l'anneau lumineux		
585	0170174	1	Wiring harness Kabelbaum	Conjunto de cables Harnais de câbles électriques		
675	0150116	1	Bolt Bolzen	Perno Boulon	M12	
676	0150117	2	Washer Scheibe	Arandela Rondelle	M12	
742	0155486	1	Throttle Actuator Gasreglerstellteil	Actuador de Acelerador Dispositif de commande des gaz		
1245	0160840	1	Connector housing, 2 pole,plug 2-Pol Stecker	Enchufe Fiche		
1246	0160841	2	Receptacle connector Steckdose	Tomacorriente Prise de courant		
1247	0160842	1	Lock wedge Haltekeil	Cuña de retención Cale de fixation		



Ref. Pos.	Part No. Artikel Nr.	Qty. St.	Description Beschreibung	Descripción Description	Measurement/Abm.	Norm
					Torque/Drehm.	Sealant Schmierstoff
1248	0161278	1	Coolant bypass wiring harness Kabelbaum für Kühlmittelumlauf	Conjunto de cables para desviación del enfriador Harnais de câbles électriques		
1249	0086983	1	Plug (threaded) Schraubverschluß	Tapón roscado Bouchon		S9
1270	0162711	1	Hexagon nut Sechskantmutter	Tuerca hexagonal Écrou hexagonal	M32	
1293	0172989	1	Diagnostic control module Diagnose-Controllermodul	Módulo controlador de diagnóstico Module contrôle de diagnostic		
1306	0182304	1	Connector Anschlußteil	Conector Connecteur		

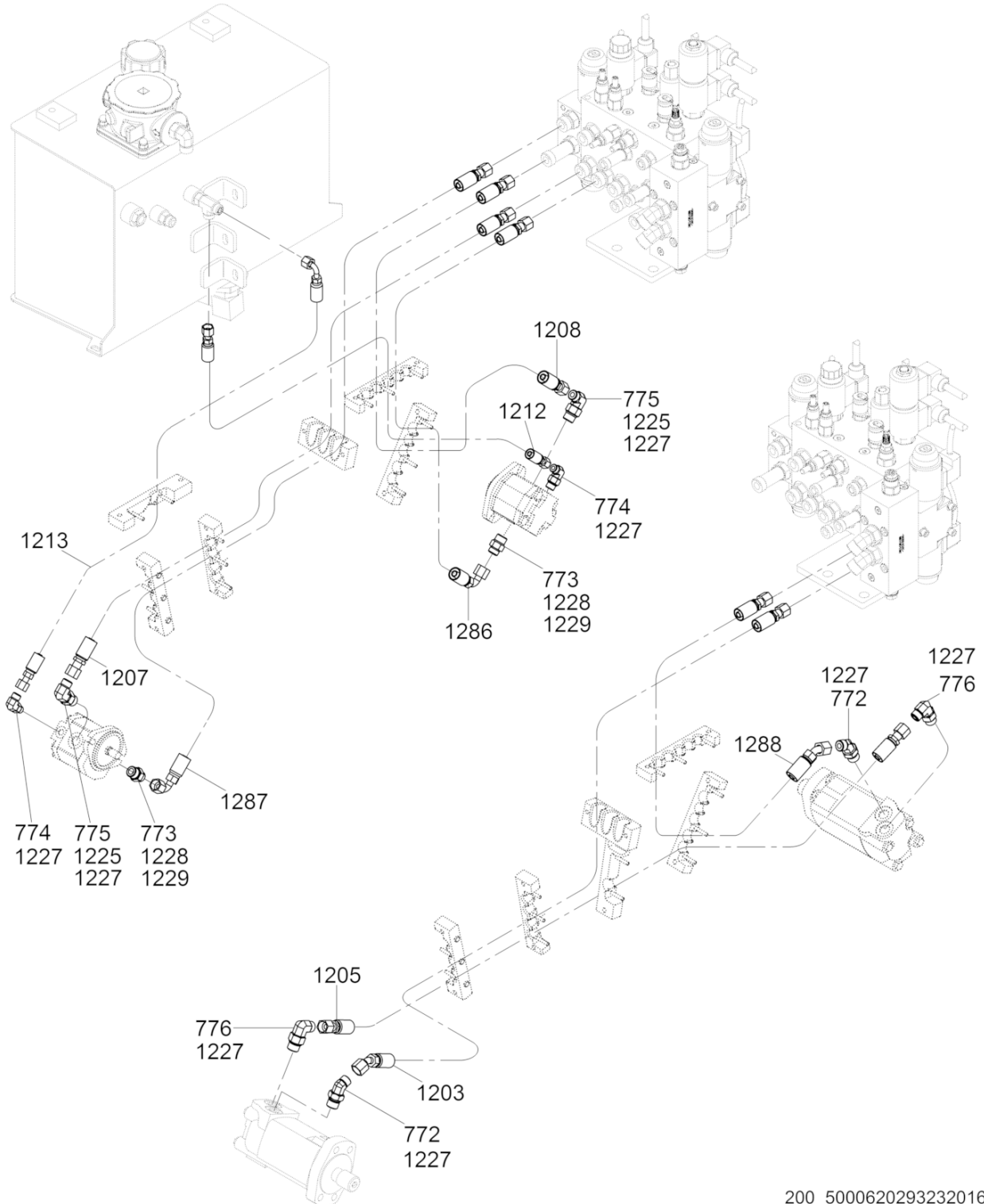

200\_5000620293232016



Ref. Pos.	Part No. Artikel Nr.	Qty. St.	Description Beschreibung	Descripción Description	Measurem./Abm.	Norm
					Torque/Drehm.	Sealant Schmierstoff
772	0151767	4	Hydraulic elbow fitting Hydraulikrohrkrümmer	Codo hidráulico Coude hydraulique	45	S8
773	0079875	2	Hydraulic fitting Hydraulikverschraubung	Unión hidráulico Raccord hydraulique	No.8 x 10	
774	0151768	2	Hydraulic elbow fitting Hydraulikrohrkrümmer	Codo hidráulico Coude hydraulique	90	
775	0081340	2	Elbow fitting Rohrkrümmer	Codo Coude	No.8 x 10 x 90	S8
776	0081340	2	Elbow fitting Rohrkrümmer	Codo Coude	No.8 x 10 x 90	
1203	5200010939	1	Hydraulic hose Hydraulikschlauch	Manguera hidráulica Tuyau hydraulique	1360	S8
1205	5200010940	1	Hydraulic hose Hydraulikschlauch	Manguera hidráulica Tuyau hydraulique	1275 38Nm/28ft.lbs	S8
1207	5200006474	1	Hydraulic hose Hydraulikschlauch	Manguera hidráulica Tuyau hydraulique	1470 60Nm/44ft.lbs	S8
1208	5200006478	1	Hydraulic hose Hydraulikschlauch	Manguera hidráulica Tuyau hydraulique	995 54Nm/40ft.lbs	S8
1212	0182222	1	Hydraulic hose Hydraulikschlauch	Manguera hidráulica Tuyau hydraulique	985mm 41Nm/30ft.lbs	S8
1213	0182221	1	Hydraulic hose Hydraulikschlauch	Manguera hidráulica Tuyau hydraulique	1525mm 41Nm/30ft.lbs	S8
1225	0080731	5	O-Ring O-Ring	Anillo-O Joint torique	0,468 x 0,078in	
1227	0080737	16	O-Ring O-Ring	Anillo-O Joint torique	0,489 x 0,070in	
1228	0080732	8	O-Ring O-Ring	Anillo-O Joint torique	0,644 x 0,087in	
1229	0080733	2	O-Ring O-Ring	Anillo-O Joint torique	0,755 x 0,097in	
1275	0170004	1	Protective Hose Kit Schutzschlauchsatz	Juego de Manguera Jue de Tuyau		
1286	5200006554	1	Hydraulic hose Hydraulikschlauch	Manguera hidráulica Tuyau hydraulique	60Nm/44ft.lbs	S8
1287	5200006476	1	Hydraulic hose Hydraulikschlauch	Manguera hidráulica Tuyau hydraulique	1510	
1288	5100014108	1	Hydraulic hose Hydraulikschlauch	Manguera hidráulica Tuyau hydraulique	1060mm	

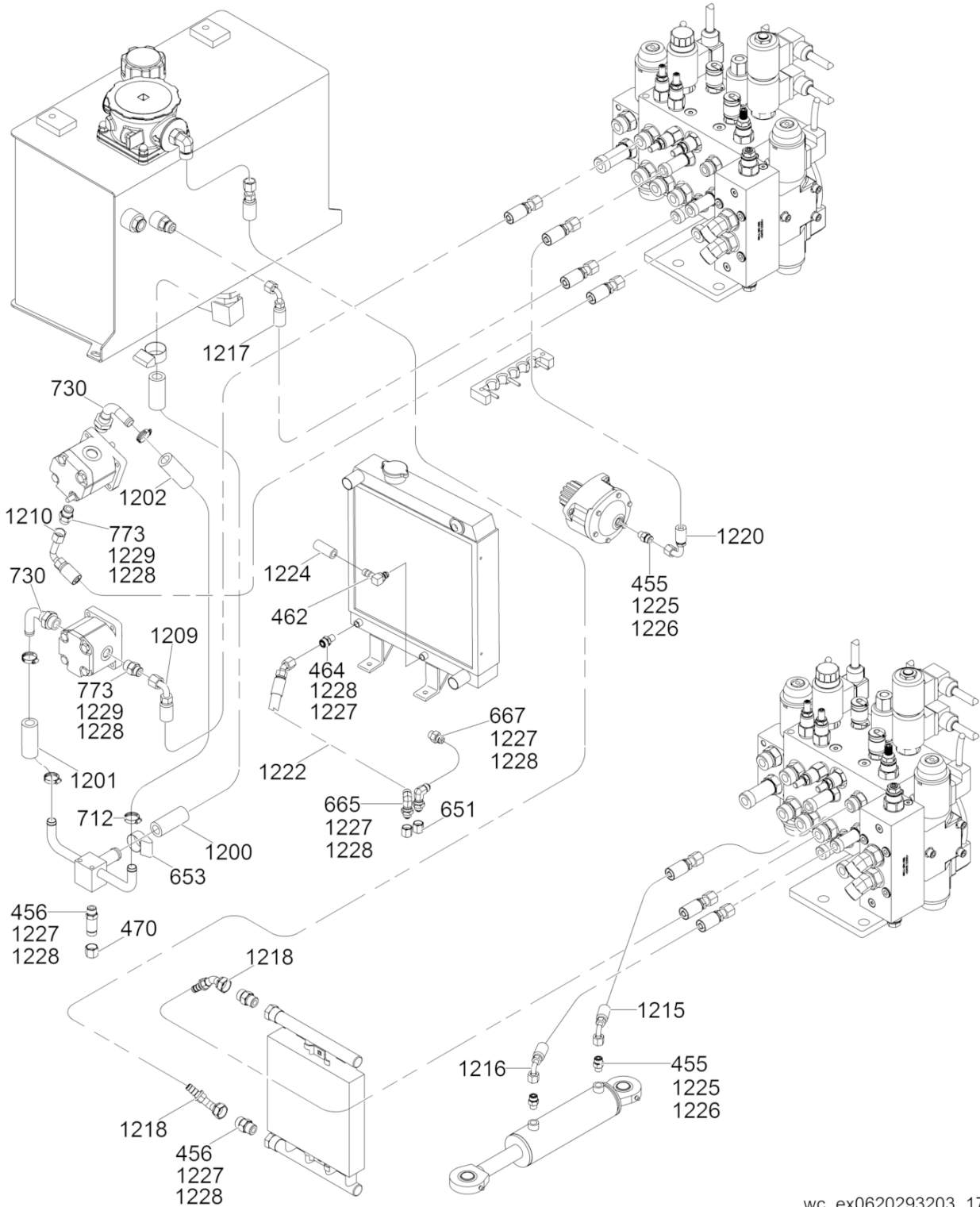

wc\_ex0620293203\_17

Ref. Pos.	Part No. Artikel Nr.	Qty. St.	Description Beschreibung	Descripción Description	Measurem./Abm.	Norm
					Torque/Drehm.	Sealant Schmierstoff
455	0078816	3	Adapter fitting Zwischenverschraubung	Unión con adaptador Raccord intermédiaire	41Nm/30ft.lbs	S8
456	0158572	2	Fitting Verschraubung	Unión Raccord	No.8	
462	0156401	1	Fitting Verschraubung	Unión Raccord	90	S9
464	0156204	1	Fitting Verschraubung	Unión Raccord	No.8-3/8 NPT	S9
470	0111716	1	Cap Kappe	Tapa Capuchon	No.8	
651	0119929	2	Fitting cap Verschraubung, Kappe	Unión, tapa Raccord, Capuchon	No.8	S8
653	0150051	2	Hose clamp Schlauchselle	Abrazaderas de manguera Agrafe de tuyau	No.16	
665	0119960	2	Fitting Verschraubung	Unión Raccord	No.8	S8
667	0119962	1	Fitting Verschraubung	Unión Raccord	No.8	S8
712	0028314	4	Clamp Selle	Abrazadera Agrafe	0,81 x 1,25in	
730	0088342	2	Fitting Verschraubung	Unión Raccord	90	S8
773	0079875	2	Hydraulic fitting Hydraulikverschraubung	Unión hidráulico Raccord hydraulique	No.8 x 10	
1200	0119663	1	Hydraulic hose Hydraulikschlauch	Manguera hidráulica Tuyau hydraulique	1135	
1201	0119664	1	Hydraulic hose Hydraulikschlauch	Manguera hidráulica Tuyau hydraulique	115	
1202	0119665	1	Hydraulic hose Hydraulikschlauch	Manguera hidráulica Tuyau hydraulique	570	
1209	0182643	1	Hydraulic hose Hydraulikschlauch	Manguera hidráulica Tuyau hydraulique	1665mm 60Nm/44ft.lbs	
1210	0182644	1	Hydraulic hose Hydraulikschlauch	Manguera hidráulica Tuyau hydraulique	1880mm 60Nm/44ft.lbs	
1215	0182223	1	Hydraulic hose Hydraulikschlauch	Manguera hidráulica Tuyau hydraulique	285mm 41Nm/30ft.lbs	S8
1216	0182636	1	Hydraulic hose Hydraulikschlauch	Manguera hidráulica Tuyau hydraulique	450mm	S8
1217	0182224	1	Hydraulic hose Hydraulikschlauch	Manguera hidráulica Tuyau hydraulique	425mm 41Nm/30ft.lbs	S8
1218	0164955	2	Hydraulic hose Hydraulikschlauch	Manguera hidráulica Tuyau hydraulique		
1220	0182225	1	Hydraulic hose Hydraulikschlauch	Manguera hidráulica Tuyau hydraulique	590mm 41Nm/30ft.lbs	S8
1224	0119934	1	Drain hose Abflussschlauch	Manguera de salida Tuyau d'écoulement	570	S8
1225	0080731	5	O-Ring O-Ring	Anillo-O Joint torique	0,468 x 0,078in	
1226	0080736	3	O-Ring O-Ring	Anillo-O Joint torique	0,364 x 0,070in	

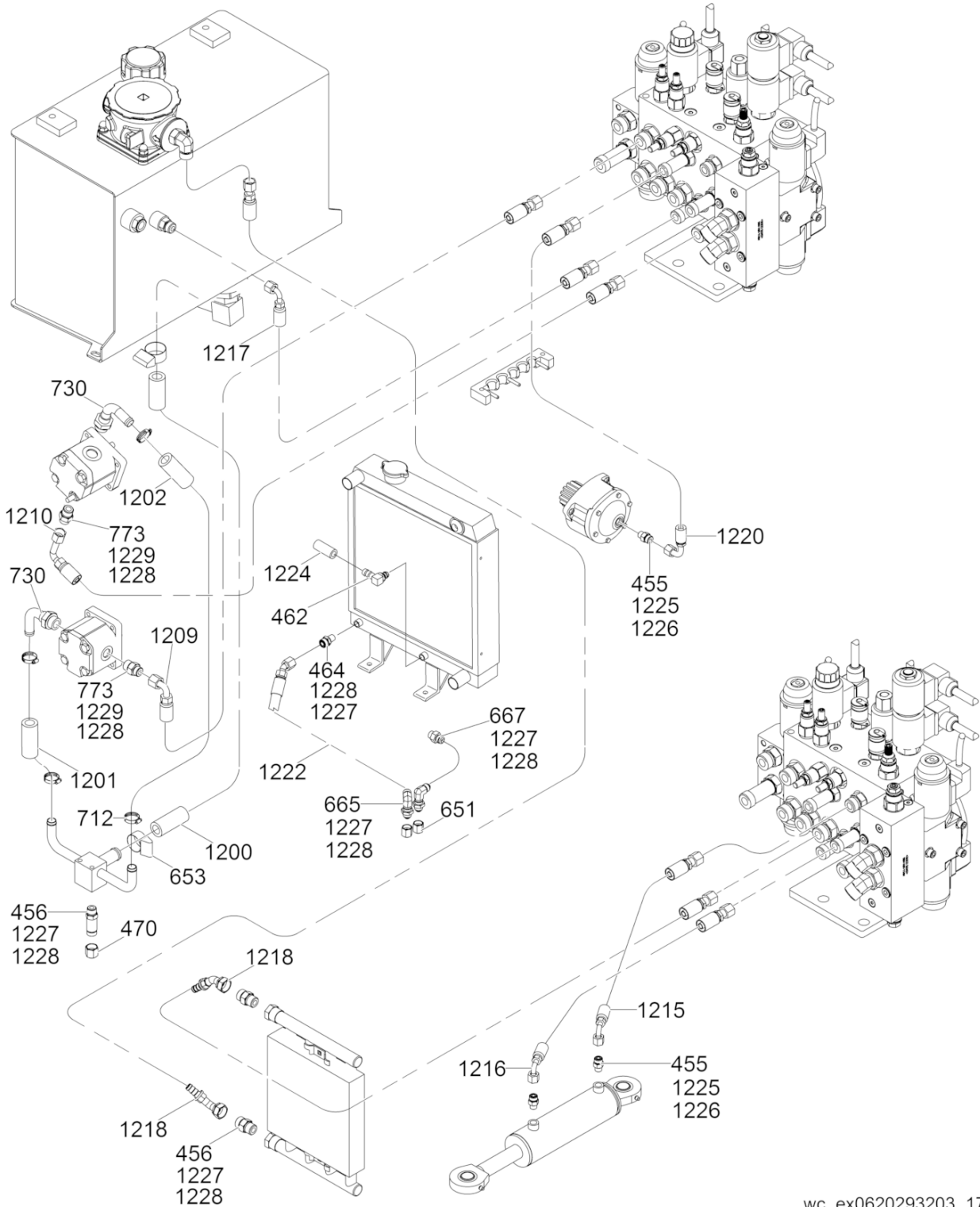

wc\_ex0620293203\_17

Ref. Pos.	Part No. Artikel Nr.	Qty. St.	Description Beschreibung	Descripción Description	Measurement./Abm.	Norm
					Torque/Drehm.	Sealant Schmierstoff
1227	0080737	16	O-Ring O-Ring	Anillo-O Joint torique	0,489 x 0,070in	
1228	0080732	8	O-Ring O-Ring	Anillo-O Joint torique	0,644 x 0,087in	
1229	0080733	2	O-Ring O-Ring	Anillo-O Joint torique	0,755 x 0,097in	
1275	0170004	1	Protective Hose Kit Schutzschlauchsatz	Juego de Manguera Jue de Tuyau		

Front Cover  
Vorderdeckel  
Tapa delantera  
Couvercle avant

RTLx-SC3

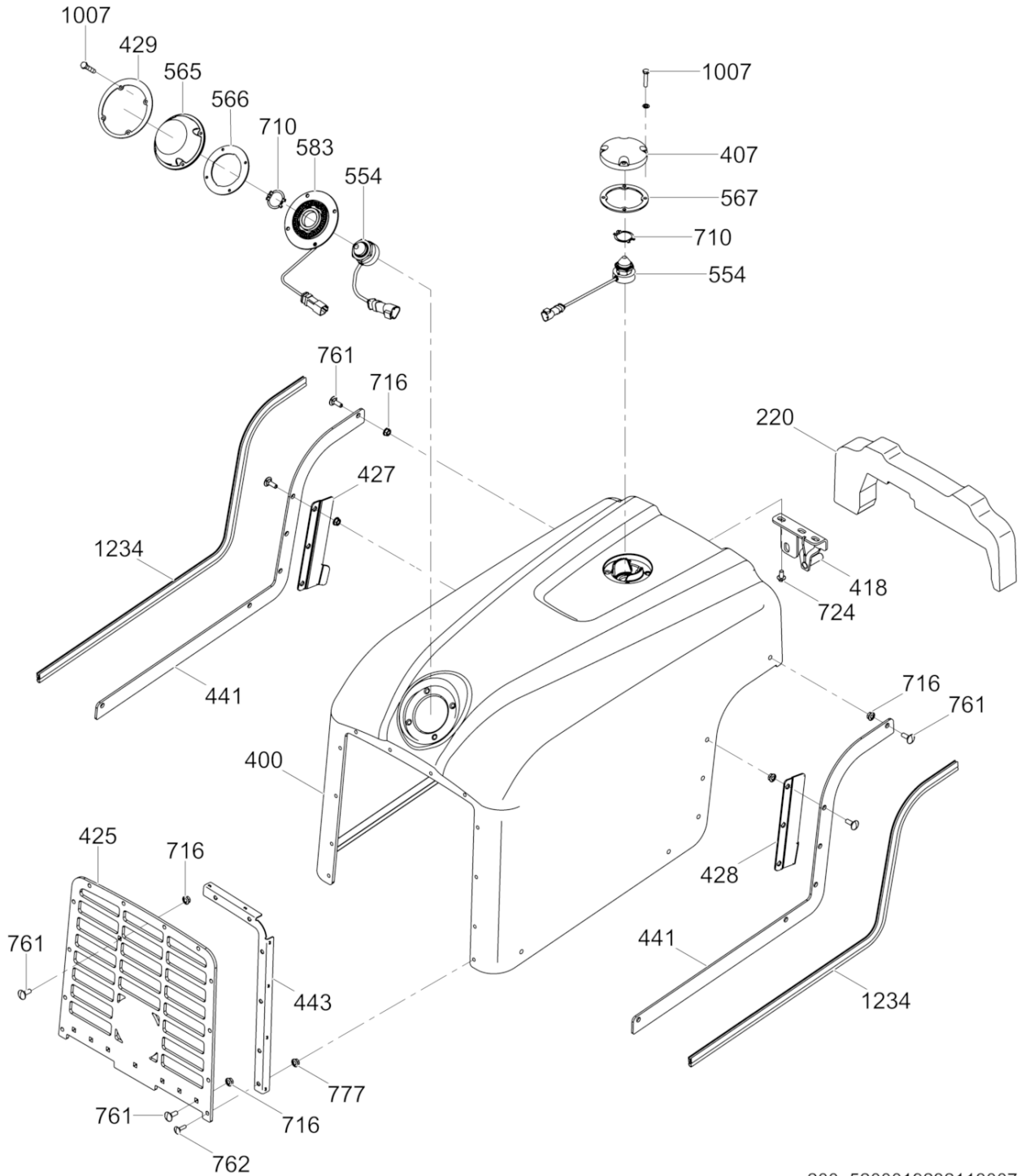

200\_5200019232113007

Ref. Pos.	Part No. Artikel Nr.	Qty. St.	Description Beschreibung	Descripción Description	Measurem./Abm.	Norm
					Torque/Drehm.	Sealant Schmierstoff
220	0150227	1	Seal Dichtung	Empaque Joint		
220	5200019759	1	Trim seal Profilgummi	Moldura Garniture		
400	5200017704	1	Front cover Vorderdeckel	Tapa delantera Couvercle avant		
407	5200018182	1	Cap Kappe	Tapa Capuchon		
418	5200019751	1	Bracket Konsole	Soporte Support		
425	5200019770	1	Grille cover Gitter	Rejilla Grille		
427	5200019757	1	Bracket Konsole	Soporte Support		
428	5200019758	1	Bracket Konsole	Soporte Support		
429	5200019775	1	Ring Ring	Anillo Anneau		
441	5200019755	2	Bracket Konsole	Soporte Support		
443	5200019774	1	Bracket Konsole	Soporte Support		
554	0170949	2	Infrared sensor Empfängerauge	Receptor de rayos Oeil récepteur		
565	5200011851	1	Cap Kappe	Tapa Capuchon		
583	0154403	1	Light ring module Lichtringmodul	Módulo de anillo de luz Module de l'anneau lumineux		
710	0172857	2	Retaining washer Scheibe	Arandela Rondelle		
716	0030066	20	Locknut Sechskantmutter	Contratuerca Contre-écrou	M8	
724	0155839	3	Hexagonal head cap screw Sechskantschraube	Tornillo hexagonal Boulon à tête hexagonale	M8 x 16	
761	0163950	20	Carriage bolt Schloßschraube	Tornillo de carruaje Boulon brut à tête bombée	M8 x 25	
762	0164579	12	Carriage bolt Schloßschraube	Tornillo de carruaje Boulon brut à tête bombée	M6 x 25	
777	0029117	12	Lock nut Sicherungsmutter	Contratuerca Contre-écrou	M6	
1007	0011474	8	Hexagonal head cap screw Sechskantschraube	Tornillo hexagonal Vis à tête hexagonale	M5 x 25 6Nm/4ft.lbs	DIN933 S3
1234	0159561	2	Seal-trim Profilgummi	Moldura Garniture	1000	

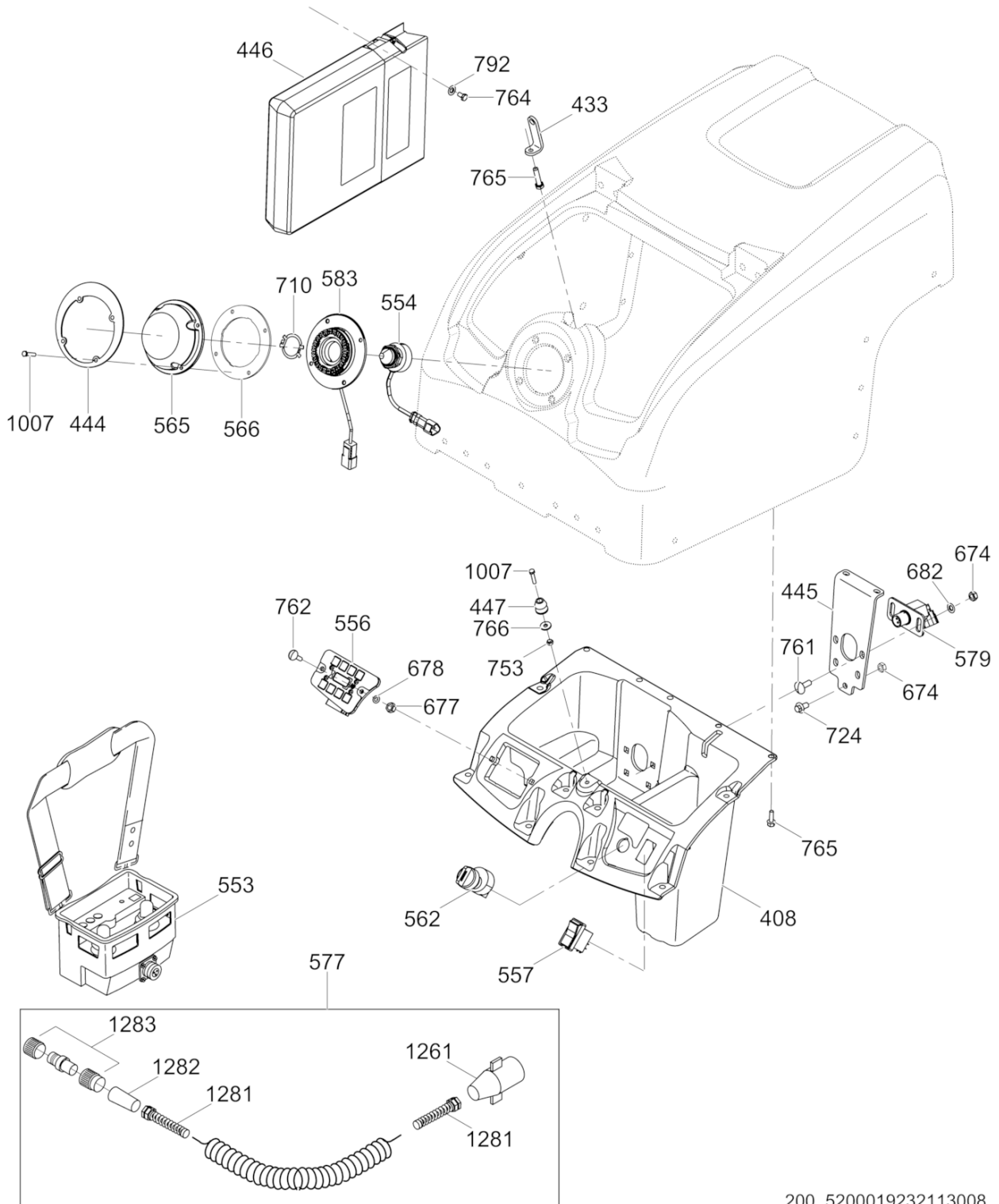

200\_5200019232113008



Ref. Pos.	Part No. Artikel Nr.	Qty. St.	Description Beschreibung	Descripción Description	Measurement/Abm.	Norm
					Torque/Drehm.	Sealant Schmierstoff
408	5200018183	1	Console Bedienungskonsole	Pupitre de mando Panneau de contrôle		
433	5200019786	1	Tab Zunge	Orejeta Onglet		
444	5200019779	1	Mount Konsole	Ménsula Support		
445	5200019784	1	Bracket Konsole	Soporte Support		
446	0153425	1	Manual holder Handbuchhalter	Soporte manual Support de manuel		
447	0170979	1	Door latch Türverriegelung	Aldaba de puerta Loquet de porte		
553	0165514	1	Transmitter module Sender	Transmisor Transmetteur		
554	0170949	2	Infrared sensor Empfängerauge	Receptor de rayos Oeil récepteur		
556	0150109	1	Module Modul	Módulo Module		
557	0150110	1	Switch Schalter	Interruptor Interrupteur		
562	0150115	1	Ignition switch Zündschalter	Interruptor de encendido Interrupteur d'ignition		
565	5200011851	1	Cap Kappe	Tapa Capuchon		
577	0154417	1	Charging cable Ladungskabel	Cable de carga Câble de charge		
579	0154405	1	Charge port module Ladungsanschlussmodul	Módulo de toma de carga Module de prise de charge		
583	0154403	1	Light ring module Lichtringmodul	Módulo de anillo de luz Module de l'anneau lumineux		
674	0010367	4	Hexagon nut Sechskantmutter	Tuerca hexagonal Écrou hexagonal	M8	DIN985
677	0010368	2	Hexagon nut Sechskantmutter	Tuerca hexagonal Écrou hexagonal	M6	DIN985
678	0010624	2	Flat washer Scheibe	Arandela Rondelle		
682	0010622	2	Flat washer Scheibe	Arandela Rondelle		
710	0172857	1	Retaining washer Scheibe	Arandela Rondelle		
724	0155839	3	Hexagonal head cap screw Sechskantschraube	Tornillo hexagonal Boulon à tête hexagonale	M8 x 16	
753	0010369	1	Hexagon nut Sechskantmutter	Tuerca hexagonal Écrou hexagonal		
761	0163950	4	Carriage bolt Schloßschraube	Tornillo de carruaje Boulon brut à tête bombée	M8 x 25	
762	0164579	2	Carriage bolt Schloßschraube	Tornillo de carruaje Boulon brut à tête bombée	M6 x 25	
764	0012356	4	Hexagonal head cap screw Sechskantschraube	Tornillo hexagonal Vis à tête hexagonale	M6 x 10 10Nm/7ft.lbs	DIN933

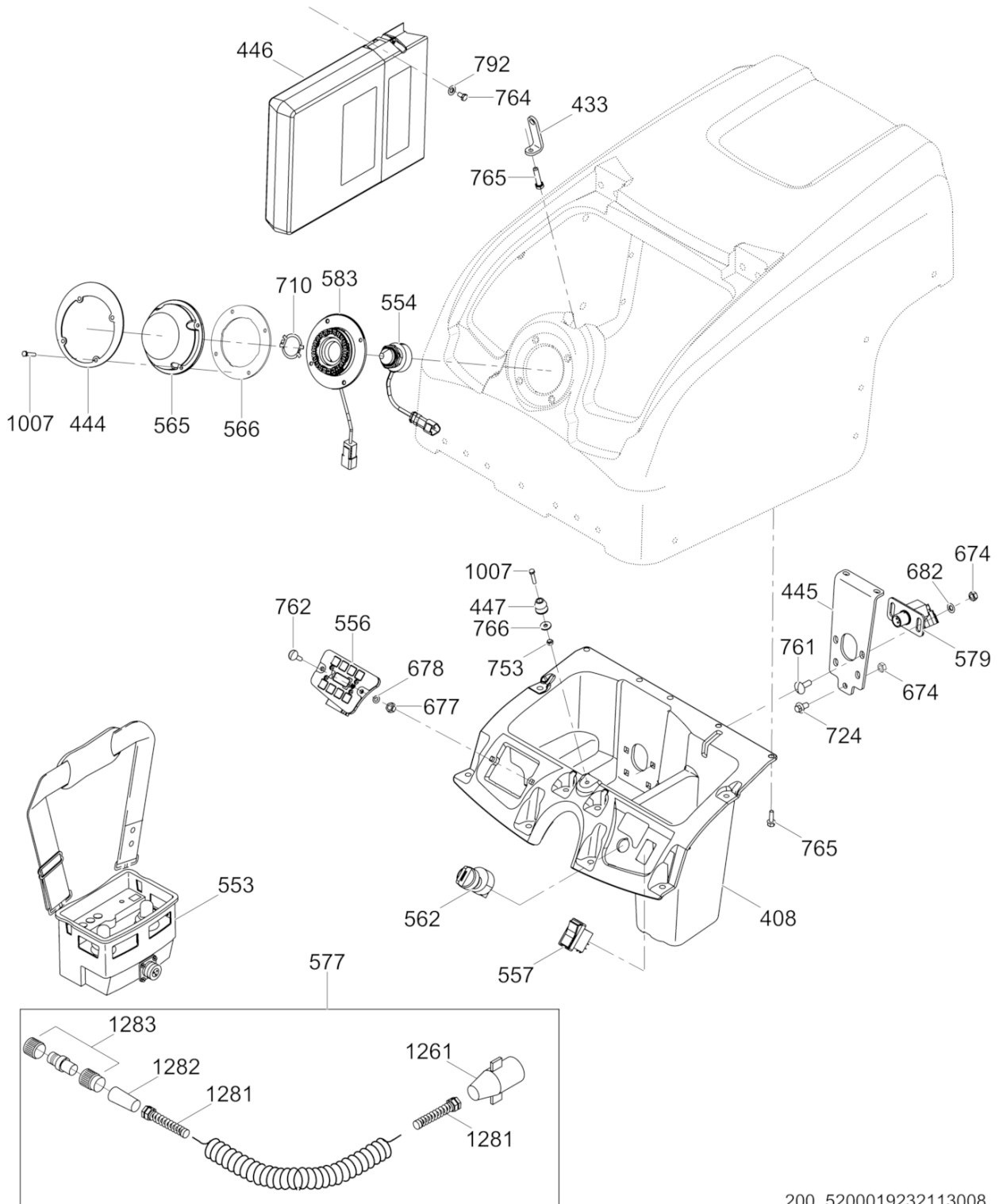

200\_5200019232113008

Ref. Pos.	Part No. Artikel Nr.	Qty. St.	Description Beschreibung	Descripción Description	Measurement./Abm.	Norm
					Torque/Drehm.	Sealant Schmierstoff
765	5200020974	1	Hexagonal flange head screw Sechskantflanschschraube	Tornillo hexagonal de brida Vis hexagonale de bride	M6 x 20 10Nm/7ft.lbs	
766	0010372	1	Flat washer Scheibe	Arandela Rondelle	B5,3	DIN9021
792	0010373	4	Flat washer Scheibe	Arandela Rondelle	6	ISO7093
1007	0011474	5	Hexagonal head cap screw Sechskantschraube	Tornillo hexagonal Vis à tête hexagonale	M5 x 25 6Nm/4ft.lbs	DIN933 S3
1261	0164490	1	Plug connector (9 pin) 9-Stift Anschlussstecker	Enchufe de (9 agujas) Fiche à (9 broches)		
1281	0089676	2	Strain relief Zugentlastung	Alivio de esfuerzos Effort à la décharge		
1282	0088821	1	Adaptor Adapter	Adaptador Adaptateur		
1283	0116889	1	Plug cpl. Stopfen kpl.	Tapón compl Bouchon compl		

Rear Cover  
Hinterdeckel  
Tapa de atrás  
Couvercle arrière

RTLx-SC3

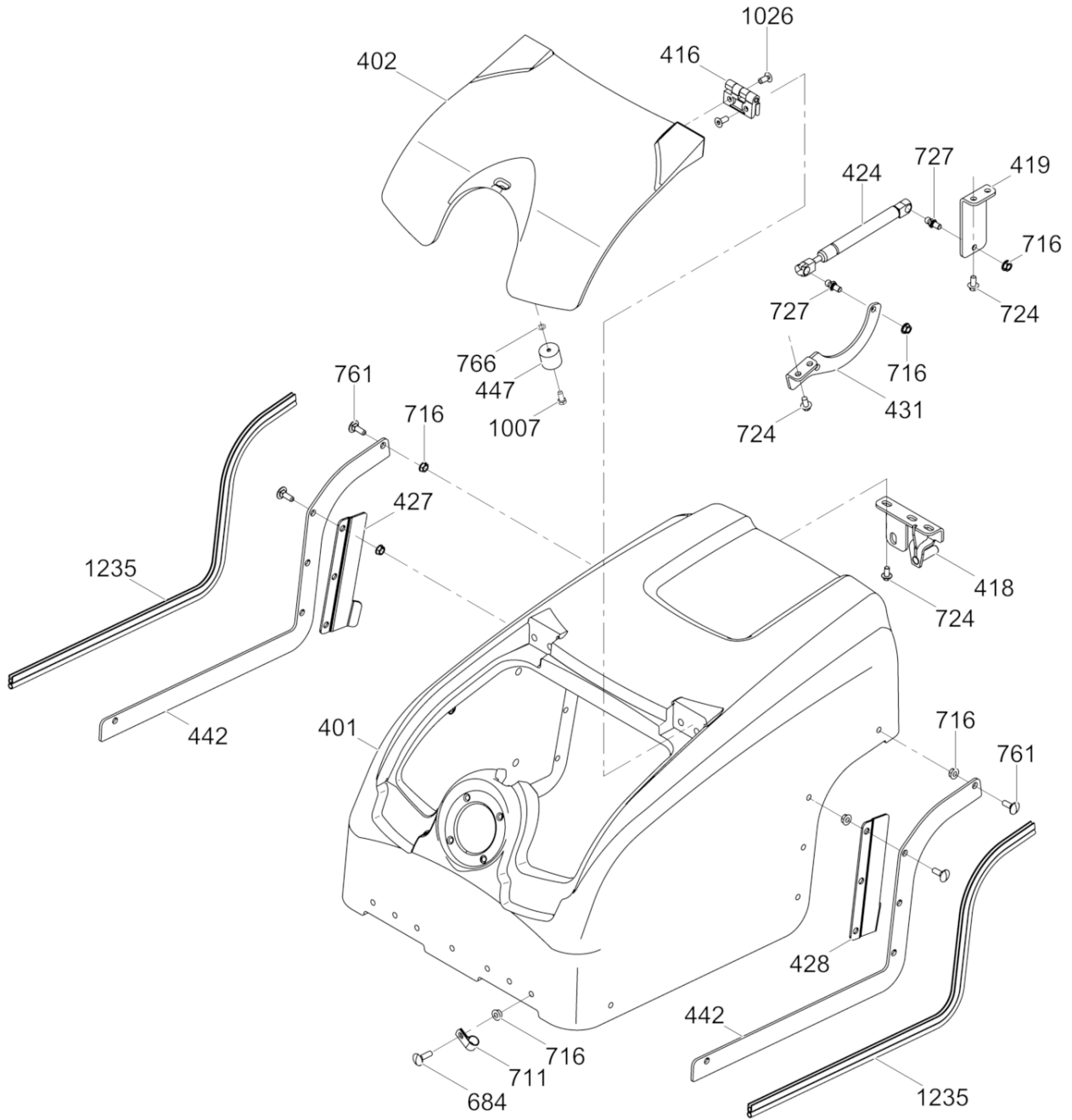

200\_5200019232100009

Ref. Pos.	Part No. Artikel Nr.	Qty. St.	Description Beschreibung	Descripción Description	Measurement./Abm.	Norm
					Torque/Drehm.	Sealant Schmierstoff
401	5200017705	1	Rear cover Hinterdeckel	Tapa de atrás Couvercle arrière		
402	5200017707	1	Access cover Abdeckplatte	Tapa de acceso Couvercle à accès		
416	0154400	2	Hinge Scharnier	Bisagra Charnière		
418	5200019751	1	Bracket Konsole	Soporte Support		
419	5200019783	1	Bracket Konsole	Soporte Support		
424	0154401	1	Cylinder Zylinder	Cilindro Cylindre		
427	5200019757	1	Bracket Konsole	Soporte Support		
428	5200019758	1	Bracket Konsole	Soporte Support		
431	5200019785	1	Lifting bracket Hebebügel	Ménsula alzadora Support de relèvement		
442	5200019756	2	Bracket Konsole	Soporte Support		
447	0170979	1	Door latch Türverriegelung	Aldaba de puerta Loquet de porte		
684	0011151	7	Carriage bolt Schloßschraube	Tornillo de carruaje Boulon brut à tête bombée	M8 x 30	DIN603
711	0163957	1	Tube clamp Rohrschelle	Abrazadera para mangueras Agrafe pour tuyaux souples	5/16in ID	
711	0163956	1	Clamp Schelle	Abrazadera Agrafe		
716	0030066	19	Locknut Sechskantmutter	Contratuercas Contre-écrou	M8	
724	0155839	7	Hexagonal head cap screw Sechskantschraube	Tornillo hexagonal Boulon à tête hexagonale	M8 x 16	
727	0155125	1	Stud Gewindebolzen	Perno prisionero Goujon	M8 x 10	
761	0163950	10	Carriage bolt Schloßschraube	Tornillo de carruaje Boulon brut à tête bombée	M8 x 25	
766	0010372	1	Flat washer Scheibe	Arandela Rondelle	B5,3	DIN9021
1007	0011474	1	Hexagonal head cap screw Sechskantschraube	Tornillo hexagonal Vis à tête hexagonale	M5 x 25 6Nm/4ft.lbs	DIN933
1026	0021563	8	Countersunk screw Senkschraube	Tornillo avellanado Vis noyée	M8 x 20 25Nm/18ft.lbs	ISO10642
1235	0159562	2	Seal-trim Profilgummi	Moldura Garniture	822	

**Drum Drive  
Bandagenantrieb**

**RTLx-SC3**

**Accionamiento de Tambor  
Entraînement de Tambour**



200\_5000620293232010

Ref. Pos.	Part No. Artikel Nr.	Qty. St.	Description Beschreibung	Descripción Description	Measurement/Abm.	Norm
					Torque/Drehm.	Sealant Schmierstoff
1	0116902	1	Drum support Bandagenträger	Soporte del tambor Support de tambour		
17	5200007278	1	Bracket Konsole	Soporte Support		
46	0150252	1	Hose clamp Schlauchschele	Abrazaderas de manguera Agrafe de tuyau		
47	0150253	1	Hose clamp Schlauchschele	Abrazaderas de manguera Agrafe de tuyau		
50	0118366	1	Cover Deckel	Tapa Couvercle		
51	0118368	1	Cover Deckel	Tapa Couvercle		
52	0116903	1	Cover Deckel	Tapa Couvercle		
53	0116906	2	Drum hub Bandagennabe	Maza de tambor Moyeu de tambour		
54	0116907	1	Drive shaft Antriebswelle	Eje motor Arbre d'entraînement		
55	0119284	1	Gear Zahnrad	Engranaje Engrenage		
57	0118796	1	Disc Scheibe	Disco Disque		
58	0181899	1	Drive motor Antriebsmotor	Motor de accionamiento Moteur d'entraînement		
59	0082961	2	Roller bearing Rollenlager	Rodamiento de rodillos Roulement à rouleaux		
60	0119285	2	Seal Dichtung	Empaque Joint		
61	0116874	1	Shaft seal Wellendichtring	Sello del eje Bague d'étanchéité	100 x 120 x 12	
62	0119286	1	Shaft seal Wellendichtring	Sello del eje Bague d'étanchéité		
63	0116869	1	Retaining ring Sicherungsring	Anillo de retención Bague d'arrêt	62 x 2	DIN471
64	0044706	2	Retaining ring Sicherungsring	Anillo de retención Bague d'arrêt	140 x 4	DIN472
65	0080666	1	Washer Scheibe	Arandela Rondelle		
66	0080667	1	Screw Schraube	Tornillo Vis	3/8-16 x 1in	S3
67	0116872	2	Square key Passfeder	Chaveta Clavette	A14 x 9 x 50	DIN6885
68	0116873	1	Square key Passfeder	Chaveta Clavette	A18 x 11 x 50	DIN6885
70	0014398	2	O-Ring O-Ring	Anillo-O Joint torique	12 x 2	
71	0078269	2	Plug (threaded) Schraubverschluß	Tapón roscado Bouchon	9/16-18in	
93	0119505	1	Plate Platte	Placa Plaque		

**Drum Drive  
Bandagenantrieb**

**RTLx-SC3**

**Accionamiento de Tambor  
Entraînement de Tambour**



200\_5000620293232010



Ref. Pos.	Part No. Artikel Nr.	Qty. St.	Description Beschreibung	Descripción Description	Measurem./Abm.	Norm
					Torque/Drehm.	Sealant Schmierstoff
94	0152276	1	O-Ring O-Ring	Anillo-O Joint torique	81,92 x 5,33	
95	0154482	1	Pinion gear Ritzel	Piñon diferencial Pignon		
671	0116871	2	Nut Mutter	Tuerca Écrou	M36 x 3 825Nm/609ft.lbs	S3
672	0150020	2	Washer Scheibe	Arandela Rondelle	M36	
674	0010367	2	Hexagon nut Sechskantmutter	Tuerca hexagonal Écrou hexagonal	M8	DIN985
682	0010622	2	Flat washer Scheibe	Arandela Rondelle		
683	0155519	3	Flange nut Flanshmutter	Tuerca de reborde Ecrou de bride	M6	
688	0117969	2	Hexagonal head cap screw Sechskantschraube	Tornillo hexagonal Boulon à tête hexagonale	M8 x 45 25Nm/18ft.lbs	
699	0011543	5	Socket head screw Zylinderschraube	Tornillo hueco Vis à six-pans creux	M8 x 20 25Nm/18ft.lbs	ISO4762
700	0011544	3	Cheese head screw Zylinderschraube	Tornillo cilíndrico Vis à tête cylindrique	M8 x 16 41Nm/30ft.lbs	ISO4762 S3
736	0111979	3	Socket head cap screw Zylinderschraube	Tornillo cilíndrico Vis à tête cylindrique	M12 x 60 85Nm/63ft.lbs	ISO4762 S4
756	0012362	3	Hexagonal head cap screw Sechskantschraube	Tornillo hexagonal Vis à tête hexagonale		
758	0072758	30	Cheese head screw Zylinderschraube	Tornillo cilíndrico Vis à tête cylindrique	M10 x 20 49Nm/36ft.lbs	ISO4762 S3
1268	0182756	1	Seal Kit Dichtungssatz	Juego-empaque Jeu-joint		

**Drum Drive w/Brake**  
**Bandagenantrieb mit Bremse**  
**Accionamiento de Tambor con Freno**  
**Entraînement de Tambour avec F**

**RTLx-SC3**

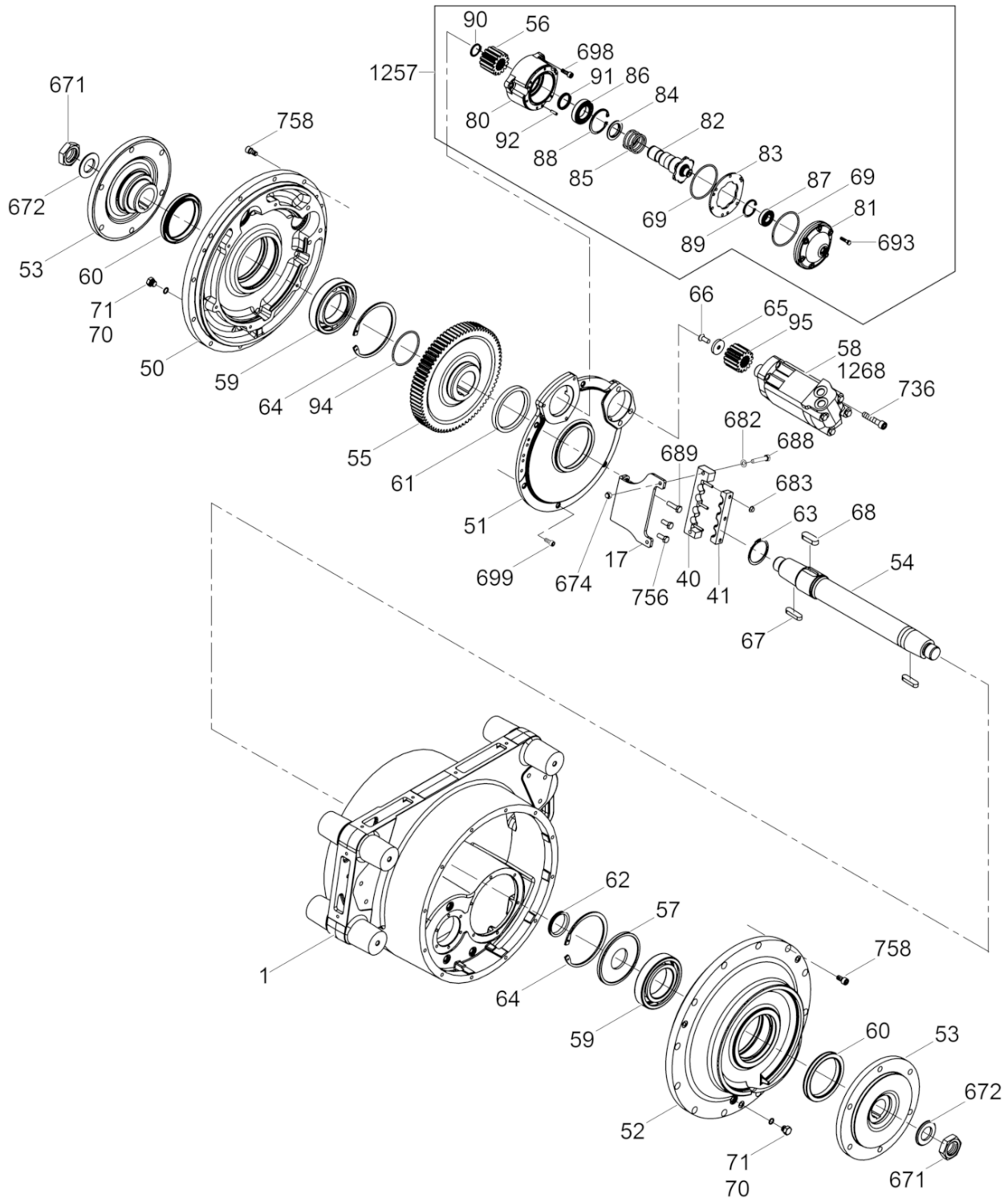

200\_5000620293232011

Ref. Pos.	Part No. Artikel Nr.	Qty. St.	Description Beschreibung	Descripción Description	Measurem./Abm.	Norm
					Torque/Drehm.	Sealant Schmierstoff
1	0116902	1	Drum support Bandagenträger	Soporte del tambor Support de tambour		
17	5200007278	1	Bracket Konsole	Soporte Support		
40	5200008651	1	Clamp Schelle	Abrazadera Agrafe		
41	5200008650	1	Clamp Schelle	Abrazadera Agrafe		
50	0118366	1	Cover Deckel	Tapa Couvercle		
51	0118368	1	Cover Deckel	Tapa Couvercle		
52	0116903	1	Cover Deckel	Tapa Couvercle		
53	0116906	2	Drum hub Bandagennabe	Maza de tambor Moyeu de tambour		
54	0116907	1	Drive shaft Antriebswelle	Eje motor Arbre d'entraînement		
55	0119284	1	Gear Zahnrad	Engranaje Engrenage		
56	0116909	1	Pinion gear Ritzel	Piñon diferencial Pignon		
57	0118796	1	Disc Scheibe	Disco Disque		
58	0181899	1	Drive motor Antriebsmotor	Motor de accionamiento Moteur d'entraînement		
59	0082961	2	Roller bearing Rollenlager	Rodamiento de rodillos Roulement à rouleaux		
60	0119285	2	Seal Dichtung	Empaque Joint		
61	0116874	1	Shaft seal Wellendichtring	Sello del eje Bague d'étanchéité	100 x 120 x 12	
62	0119286	1	Shaft seal Wellendichtring	Sello del eje Bague d'étanchéité		
63	0116869	1	Retaining ring Sicherungsring	Anillo de retención Bague d'arrêt	62 x 2	DIN471
64	0044706	2	Retaining ring Sicherungsring	Anillo de retención Bague d'arrêt	140 x 4	DIN472
65	0080666	1	Washer Scheibe	Arandela Rondelle		
66	0080667	1	Screw Schraube	Tornillo Vis	3/8-16 x 1in	
67	0116872	2	Square key Passfeder	Chaveta Clavette	A14 x 9 x 50	DIN6885
68	0116873	1	Square key Passfeder	Chaveta Clavette	A18 x 11 x 50	DIN6885
69	0119329	3	O-Ring O-Ring	Anillo-O Joint torique	85,32 x 3,53	
70	0014398	2	O-Ring O-Ring	Anillo-O Joint torique	12 x 2	

**Drum Drive w/Brake**  
**Bandagenantrieb mit Bremse**  
**Accionamiento de Tambor con Freno**  
**Entraînement de Tambour avec F**

**RTLx-SC3**

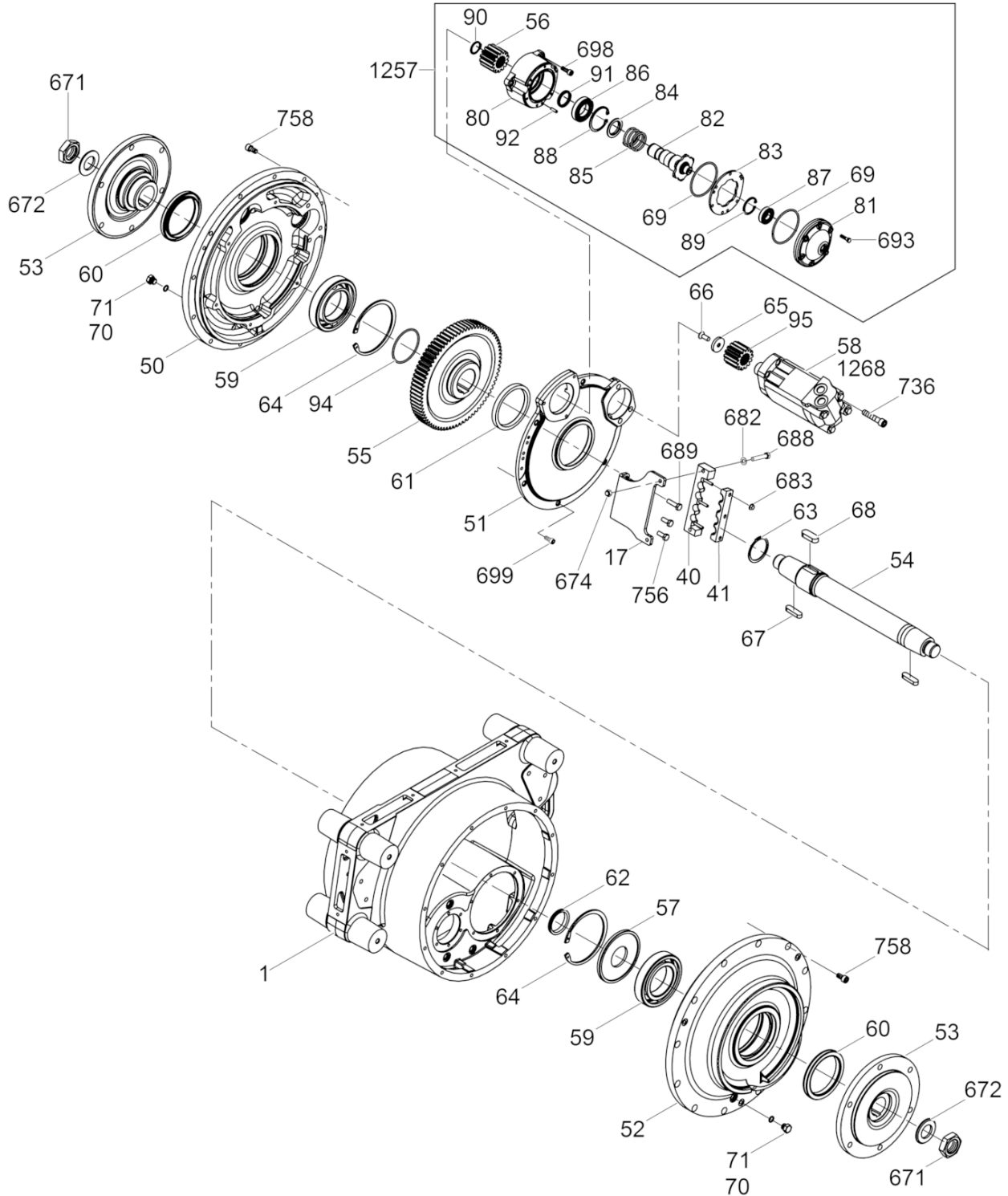

200\_5000620293232011

Ref. Pos.	Part No. Artikel Nr.	Qty. St.	Description Beschreibung	Descripción Description	Measurement./Abm.	Norm
					Torque/Drehm.	Sealant Schmierstoff
71	0078269	2	Plug (threaded) Schraubverschluss	Tapón roscado Bouchon	9/16-18in	
80	0119377	1	Housing Gehäuse	Caja Carter		
81	0117564	1	Cover Deckel	Tapa Couvercle		
82	0154320	1	Shaft Welle	Eje Arbre		
83	0117612	1	Plate Platte	Placa Plaque		
84	0151152	1	Ring Ring	Anillo Anneau		
85	0085783	1	Spring Feder	Resorte Ressort		
86	0027402	1	Grooved ball bearing Rillenkugellager	Rodamiento de bolas Roulement à billes		
87	2006236	1	Grooved ball bearing Rillenkugellager	Rodamiento de bolas Roulement à billes		
88	2001042	1	Retaining ring Sicherungsring	Anillo de retención Bague d'arrêt	62 x 2	DIN472
89	2004639	1	Retaining ring Sicherungsring	Anillo de retención Bague d'arrêt	42 x 1,75	DIN472
90	0152277	1	Retaining ring Sicherungsring	Anillo de retención Bague d'arrêt	1,25 x 0,05	
91	0089840	1	Shaft seal Wellendichtring	Sello del eje Bague d'étanchéité		
92	0054245	3	Roll pin Spannstift	Pasador Goupille de tension	7/32 x 3/4 in	
93	0119505	1	Plate Platte	Placa Plaque		
94	0152276	1	O-Ring O-Ring	Anillo-O Joint torique	81,92 x 5,33	
95	0154482	1	Pinion gear Ritzel	Piñon diferencial Pignon		
671	0116871	2	Nut Mutter	Tuerca Écrou	M36 x 3 825Nm/609ft.lbs	S3
672	0150020	2	Washer Scheibe	Arandela Rondelle	M36	
674	0010367	2	Hexagon nut Sechskantmutter	Tuerca hexagonal Écrou hexagonal	M8	DIN985
682	0010622	2	Flat washer Scheibe	Arandela Rondelle		
683	0153379	3	Gasket Dichtung	Junta Joint		
688	0117969	2	Hexagonal head cap screw Sechskantschraube	Tornillo hexagonal Boulon à tête hexagonale	M8 x 45 25Nm/18ft.lbs	
693	0011469	6	Hexagonal head cap screw Sechskantschraube	Tornillo hexagonal Vis à tête hexagonale	M6 x 25 10Nm/7ft.lbs	DIN933 S4
698	0011542	3	Cheese head screw Zylinderschraube	Tornillo cilíndrico Vis à tête cylindrique	41Nm/30ft.lbs	S3

**Drum Drive w/Brake**  
**Bandagenantrieb mit Bremse**  
**Accionamiento de Tambor con Freno**  
**Entraînement de Tambour avec F**

**RTLx-SC3**

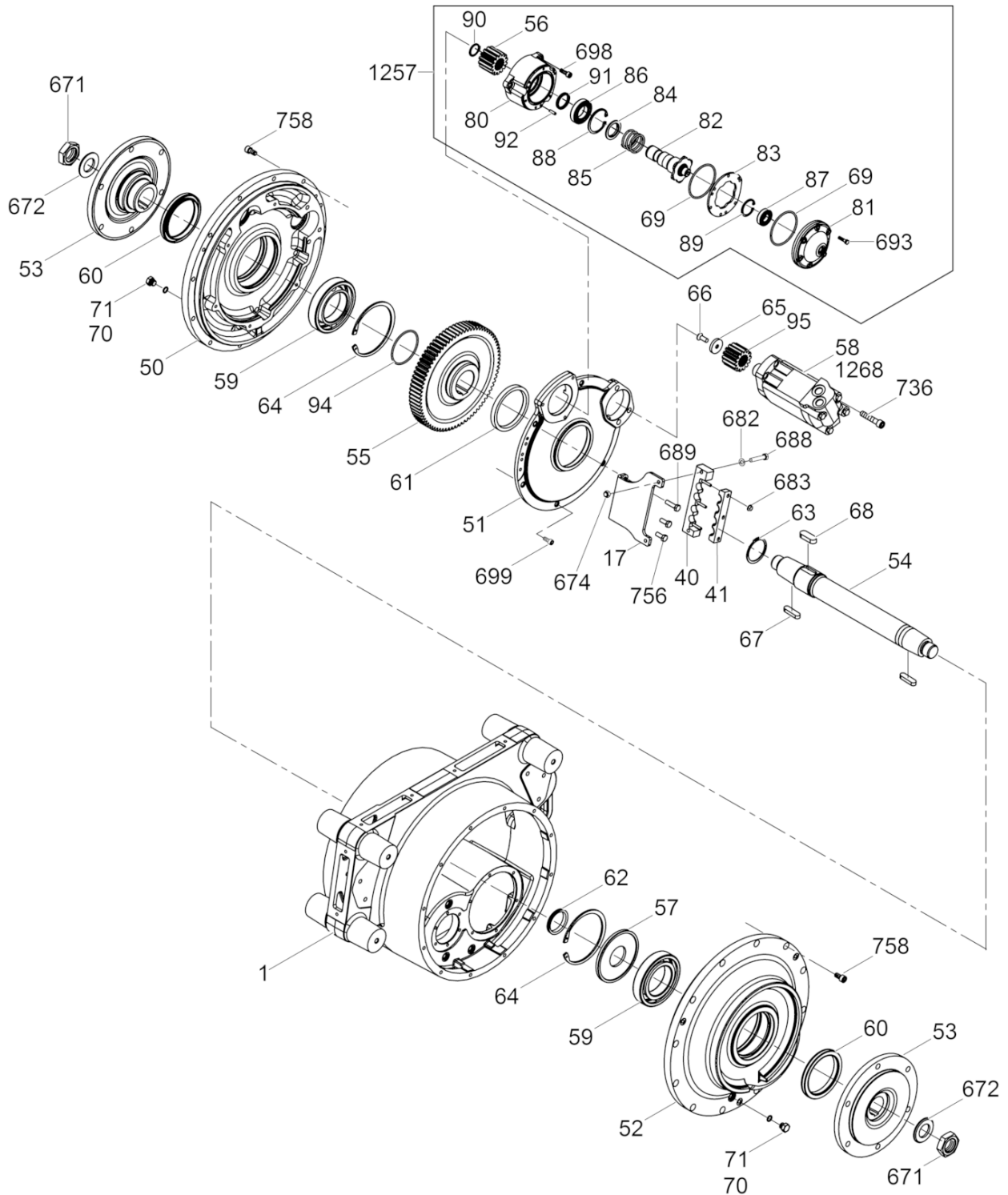

200\_5000620293232011

Ref. Pos.	Part No. Artikel Nr.	Qty. St.	Description Beschreibung	Descripción Description	Measurement/Abm.	Norm
					Torque/Drehm.	Sealant Schmierstoff
699	0011543	4	Socket head screw Zylinderschraube	Tornillo hueco Vis à six-pans creux	M8 x 20 25Nm/18ft.lbs	ISO4762
736	0111979	3	Socket head cap screw Zylinderschraube	Tornillo cilíndrico Vis à tête cylindrique	M12 x 60 85Nm/63ft.lbs	ISO4762 S4
756	0012362	2	Hexagonal head cap screw Sechskantschraube	Tornillo hexagonal Vis à tête hexagonale		
758	0072758	30	Cheese head screw Zylinderschraube	Tornillo cilíndrico Vis à tête cylindrique	M10 x 20 49Nm/36ft.lbs	ISO4762 S3
1257	0163621	1	Brake cpl. Bremse kpl.	Freno compl. Frein compl.		
1268	0182756	1	Seal Kit Dichtungssatz	Juego-empaque Jeu-joint		
1689	0011541	1	Cheese head screw Zylinderschraube	Tornillo cilíndrico Vis à tête cylindrique		

**Front Drum  
Vorderbandage  
Tambor Delantero  
Tambour Avant**

**RTLx-SC3**

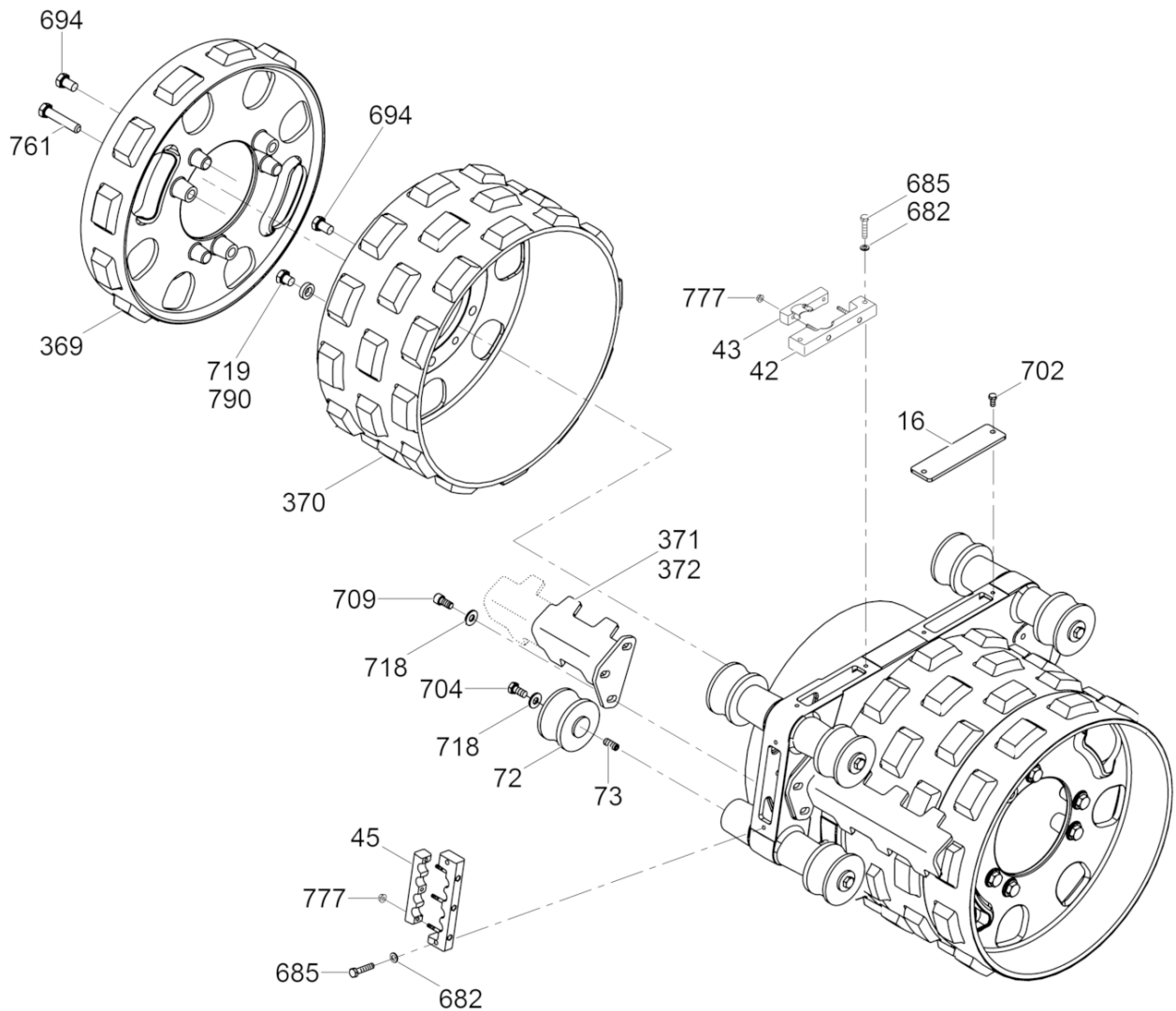

200\_5200008538100012



Ref. Pos.	Part No. Artikel Nr.	Qty. St.	Description Beschreibung	Descripción Description	Measurement./Abm.	Norm
					Torque/Drehm.	Sealant Schmierstoff
16	0150306	1	Plate Platte	Placa Plaque		
42	0181900	1	Hose clamp Schlauchschele	Abrazaderas de manguera Agrafe de tuyau		
43	0181901	1	Hose clamp Schlauchschele	Abrazaderas de manguera Agrafe de tuyau		
44	0150252	1	Hose clamp Schlauchschele	Abrazaderas de manguera Agrafe de tuyau		
45	0150253	1	Hose clamp Schlauchschele	Abrazaderas de manguera Agrafe de tuyau		
72	2004814	6	Shockmount Gimmetall-Kerblager mit Bund	Amortiguador Silentbloc	100 x 58	
73	0180963	6	Setscrew Gewindestift	Tornillo Vis	M12 x 35	
369	5200003694	4	Drum extension Bandageverlängerung	Tambor de Extensión Extension de Tambour		
370	5200009074	2	Narrow drum Bandage-schmal	Tambor-angosto Tambour étroit		
371	5200007070	4	Wide Scraper Bar Kit Abstreifersatz (breit)	Juego de barra raspadora (anch) barre de curette (large)		
372	5200007073	4	Narrow Scraper Bar Kit Abstreifersatz (schmal)	Juego de barra raspadora (angosto) Jeu de barre de curette (étroit)		
682	0010622	4	Flat washer Scheibe	Arandela Rondelle		
685	0011341	4	Hexagonal head cap screw Sechskantschraube	Tornillo hexagonal Vis à tête hexagonale	M8 x 40 25Nm/18ft.lbs	DIN931 S3
694	0011524	12	Hexagonal head cap screw Sechskantschraube	Tornillo hexagonal Vis à tête hexagonale	M16 x 25 211Nm/156ft.lbs	DIN933 S3
702	0012361	2	Hexagonal head cap screw Sechskantschraube	Tornillo hexagonal Vis à tête hexagonale	M8 x 16 25Nm/18ft.lbs	DIN933 S3
704	0013002	6	Hexagonal head cap screw Sechskantschraube	Tornillo hexagonal Vis à tête hexagonale	M12 x 25 86Nm/63ft.lbs	DIN933 S3
709	0017087	12	Socket head cap screw Zylinderschraube	Tornillo cilíndrico Vis à tête cylindrique	M12 x 30 86Nm/63ft.lbs	ISO4762 S3
718	0031565	18	Lockwasher Spannscheibe	Arandela elástica Rondelle de ressort	12	DIN6796
719	0031826	6	Screw Schraube	Tornillo Vis	M16 x 16 210Nm/155ft.lbs	S3
761	0011380	12	Hexagonal head cap screw Sechskantschraube	Tornillo hexagonal Boulon à tête hexagonale	M16 x 80 210Nm/155ft.lbs	DIN 931
777	0029117	5	Lock nut Sicherungsmutter	Contratuerca Contre-écrou	M6	
790	5200009076	12	Washer Scheibe	Arandela Rondelle	M16	

Rear Drum  
Hinterbandage  
Tambor de Atrás  
Tambour Arrière

RTLx-SC3

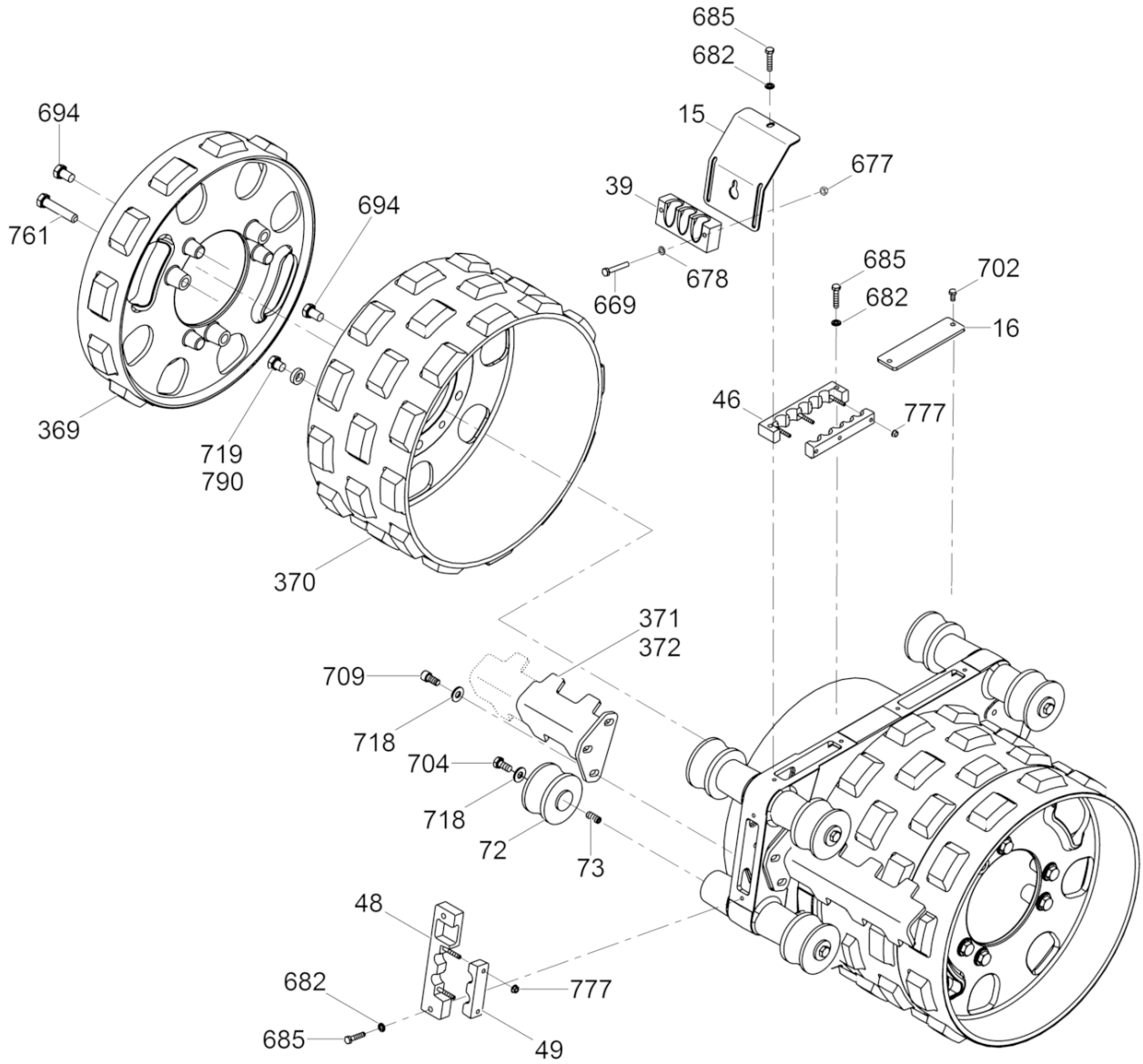

200\_5200008538101013

Ref. Pos.	Part No. Artikel Nr.	Qty. St.	Description Beschreibung	Descripción Description	Measurement./Abm.	Norm
					Torque/Drehm.	Sealant Schmierstoff
15	0155293	1	Guard Schutz	Protector Protection		
16	0150306	1	Plate Platte	Placa Plaque		
39	5200010002	1	Bracket Konsole	Soporte Support		
46	0181902	1	Hose clamp Schlauchschelle	Abrazaderas de manguera Agrafe de tuyau		
47	0181903	1	Hose clamp Schlauchschelle	Abrazaderas de manguera Agrafe de tuyau		
48	0181904	1	Hose clamp Schlauchschelle	Abrazaderas de manguera Agrafe de tuyau		
49	0181905	1	Hose clamp Schlauchschelle	Abrazaderas de manguera Agrafe de tuyau		
72	2004814	6	Shockmount Gimetall-Kerblager mit Bund	Amortiguador Silentbloc	100 x 58	
73	0180963	6	Setscrew Gewindestift	Tornillo Vis	M12 x 35	
369	5200003694	2	Drum extension Bandageverlängerung	Tambor de Extensión Extension de Tambour		
370	5200009074	2	Narrow drum Bandage-schmal	Tambor-angosto Tambour étroit		
371	5200007070	4	Wide Scraper Bar Kit Abstreifersatz (breit)	Juego de barra raspadora (anch) barre de curette (large)		
372	5200007073	4	Narrow Scraper Bar Kit Abstreifersatz (schmal)	Juego de barra raspadora (angosto) Jeu de barre de curette (étroi)		
669	0011466	2	Hexagonal head cap screw Sechskantschraube	Tornillo hexagonal Vis à tête hexagonale	M6 x 40 10Nm/7ft.lbs	DIN933
677	0010368	2	Hexagon nut Sechskantmutter	Tuerca hexagonal Écrou hexagonal	M6	DIN985
678	0010624	2	Flat washer Scheibe	Arandela Rondelle		
682	0010622	5	Flat washer Scheibe	Arandela Rondelle		
685	0011341	5	Hexagonal head cap screw Sechskantschraube	Tornillo hexagonal Vis à tête hexagonale	M8 x 40 25Nm/18ft.lbs	DIN931 S3
694	0011524	12	Hexagonal head cap screw Sechskantschraube	Tornillo hexagonal Vis à tête hexagonale	M16 x 25 210Nm/155ft.lbs	DIN933 S3
702	0012361	2	Hexagonal head cap screw Sechskantschraube	Tornillo hexagonal Vis à tête hexagonale	M8 x 16 25Nm/18ft.lbs	DIN933 S3
704	0013002	6	Hexagonal head cap screw Sechskantschraube	Tornillo hexagonal Vis à tête hexagonale	M12 x 25 86Nm/63ft.lbs	DIN933 S3
709	0017087	12	Socket head cap screw Zylinderschraube	Tornillo cilíndrico Vis à tête cylindrique	M12 x 30 86Nm/63ft.lbs	ISO4762 S3
718	0031565	18	Lockwasher Spannscheibe	Arandela elástica Rondelle de ressort	12	DIN6796
719	0031826	6	Screw Schraube	Tornillo Vis	M16 x 16 210Nm/155ft.lbs	S3
761	0011380	6	Hexagonal head cap screw Sechskantschraube	Tornillo hexagonal Boulon à tête hexagonale	M16 x 80 210Nm/155ft.lbs	DIN 931

Rear Drum  
Hinterbandage  
Tambor de Atrás  
Tambour Arrière

RTLx-SC3

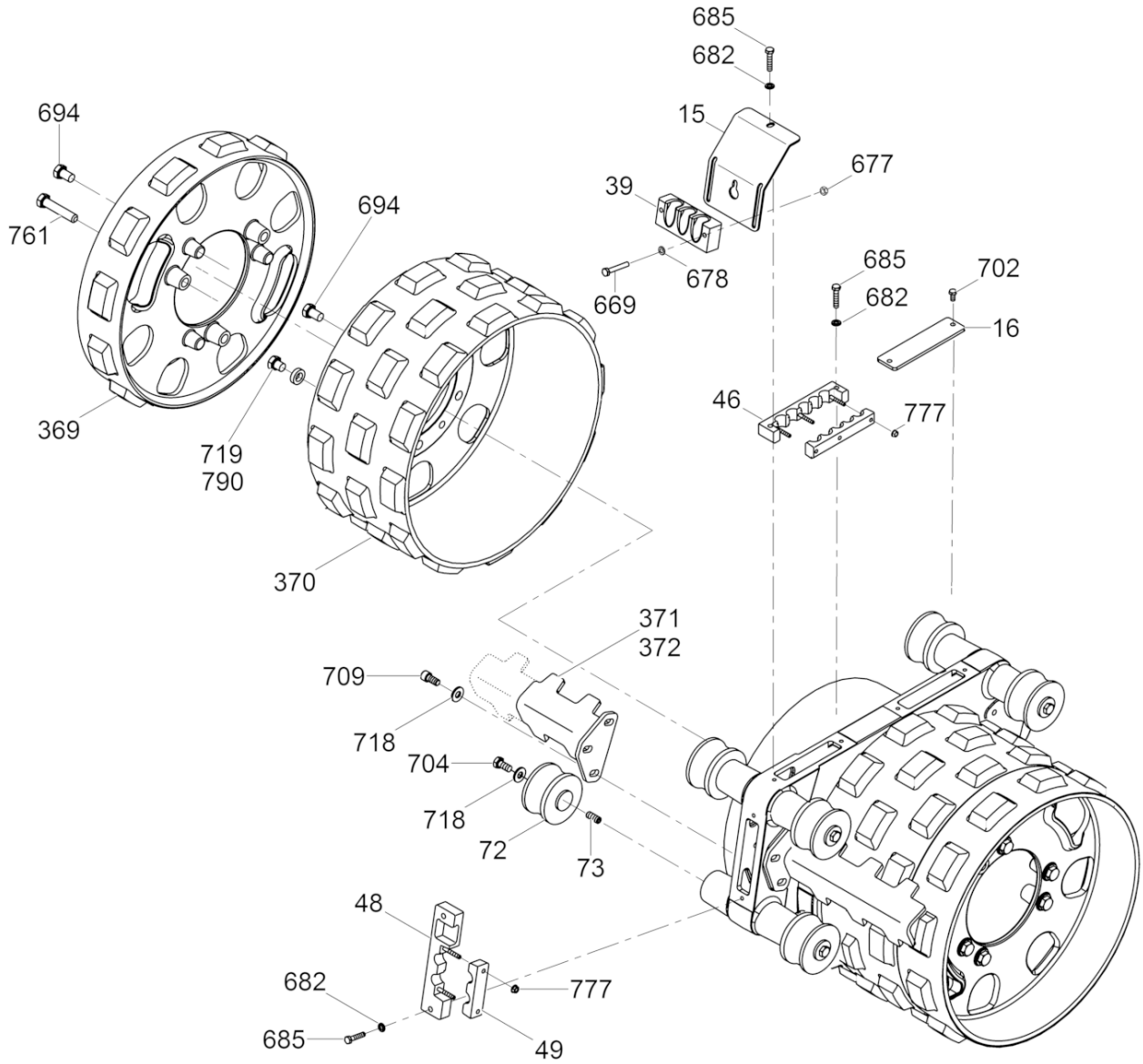

200\_5200008538101013

Ref. Pos.	Part No. Artikel Nr.	Qty. St.	Description Beschreibung	Descripción Description	Measurement/Abm.	Norm
					Torque/Drehm.	Sealant Schmierstoff
777	0029117	5	Lock nut Sicherungsmutter	Contratuerca Contre-écrou	M6	
790	5200009076	12	Washer Scheibe	Arandela Rondelle	M16	

Exciter cpl.  
Erreger kpl.  
Excitador compl.  
Excitatrice compl.

RTLx-SC3

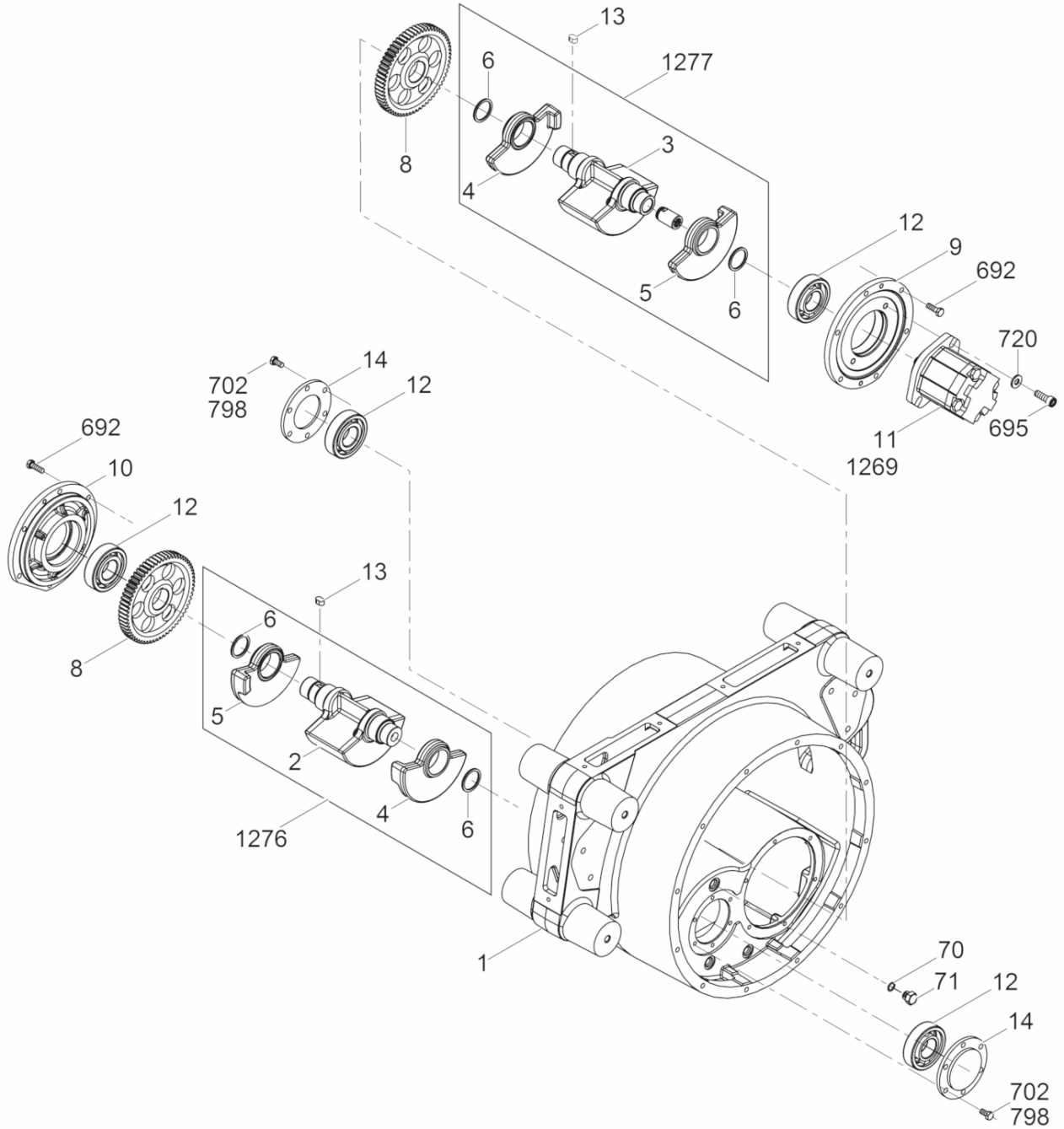

200\_5000620293232014

Ref. Pos.	Part No. Artikel Nr.	Qty. St.	Description Beschreibung	Descripción Description	Measurement./Abm.	Norm
					Torque/Drehm.	Sealant Schmierstoff
1	0116902	1	Drum support Bandagenträger	Soporte del tambor Support de tambour		
2	0171032	2	Exciter shaft w/o counterbore Erregerwelle ohne Senkung	Eje del excitador s/escariador Arbre de l'excitatrice sans lo		
3	0171033	2	Exciter shaft w/counterbore Erregerwelle mit Senkung	Eje del excitador c/escariador Arbre de l'excitatrice avec lo		
4	0171034	4	Eccentric weight Unwucht	Masa excéntrica Balourd excentrique		
5	0171035	4	Eccentric weight Unwucht	Masa excéntrica Balourd excentrique		
6	0171028	8	Retaining ring Sicherungsring	Anillo de retención Bague d'arrêt	45 x 1,69in	
8	5200001515	2	Gear Zahnrad	Engranaje Engrenage		
9	0116958	1	Cover Deckel	Tapa Couvercle		
10	0116959	1	Bearing cover Lagerdeckel	Tapa del rodamiento Tapa del rodamiento		
11	0182917	1	Exciter motor Erregermotor	Motor excitador Moteur d'excitatrice		
12	0080742	4	Roller bearing Rollenlager	Rodamiento de rodillos Roulement à rouleaux		
13	0115699	2	Square key Passfeder	Chaveta Clavette	A10 x 8 x 16	DIN6885
14	0171000	4	Cover Deckel	Tapa Couvercle		
70	0014398	3	O-Ring O-Ring	Anillo-O Joint torique	12 x 2	
71	0078269	3	Plug (threaded) Schraubverschluss	Tapón roscado Bouchon	9/16-18in	
692	0011457	12	Hexagonal head cap screw Sechskantschraube	Tornillo hexagonal Vis à tête hexagonale	M8 x 25 25Nm/18ft.lbs	DIN933 S3
695	0011534	2	Cheese head screw Zylinderschraube	Tornillo cilíndrico Vis à tête cylindrique	M10 x 30 49Nm/36ft.lbs	ISO4762
702	0012361	12	Hexagonal head cap screw Sechskantschraube	Tornillo hexagonal Vis à tête hexagonale	M8 x 16 25Nm/18ft.lbs	DIN933 S3
720	0033988	2	Lockwasher Spannscheibe	Arandela elástica Rondelle de ressort	10	DIN6796
798	0172326	24	Flat washer Scheibe	Arandela elástica Rondelle de ressort	8.4	
1269	5200024514	1	Seal Kit Dichtungssatz	Juego-empaque Jeu-joint		
1276	0171445	2	Exciter Shaft Kit w/o counterbore Erregerwellensatz ohne Senkung	Juego-eje del excitador s/escariador Jeu-arbre de l'excitatrice san		
1277	0171446	2	Exciter Shaft Kit w/counterbore Erregerwellensatz mit Senkung	Juego-eje del excitador c/escariador Jeu-arbre de l'excitatrice ave		

**Hydraulic Manifold**  
**Hydraulikverteiler**  
**Distribuidor Hidráulico**  
**Tubulure Hydraulique**

**RTLx-SC3**

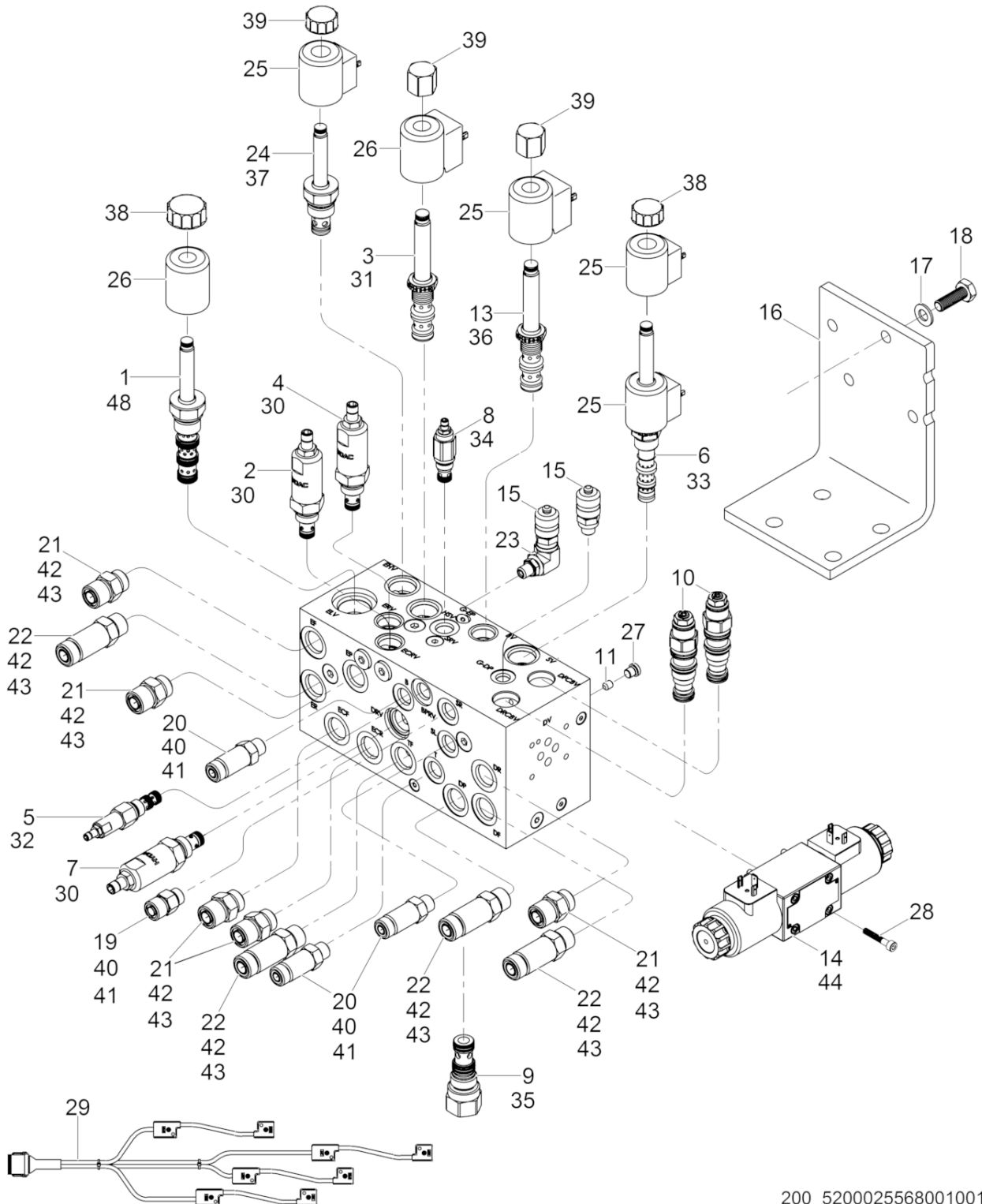

200\_5200025568001001



Ref. Pos.	Part No. Artikel Nr.	Qty. St.	Description Beschreibung	Descripción Description	Measurem./Abm.	Norm
					Torque/Drehm.	Sealant Schmierstoff
1	5100016775	1	Solenoid valve Ventil-Solenoid	Válvula-solenoid Électrovanne		
2	5100016776	1	Relief valve Überdruckventil	Válvula de desahoga Soupape de surpression		
3	5100016777	1	Solenoid valve Ventil-Solenoid	Válvula-solenoid Électrovanne		
4	5100016778	1	Relief valve Überdruckventil	Válvula de desahoga Soupape de surpression		
5	5100016779	1	Brake valve Bremsventil	Válvula de frenaje Robinet de freinage		
6	5100016780	1	Steering valve Steuerventil	Válvula de dirección Soupape de direction		
7	5100016781	1	Relief valve Überdruckventil	Válvula de desahoga Soupape de surpression		
8	5100016782	1	Steering valve Steuerventil	Válvula de dirección Soupape de direction		
9	5100016783	1	Bypass valve Bypassventil	Válvula de desviador Soupape de dérivation		
10	5100016784	2	Counterbalance valve Ausgleichsventil	Válvula de compensación Soupape de contrecharge		
11	5100016785	1	Setscrew Gewindestift	Tornillo Vis	2,70	
12	5100016786	1	Setscrew Gewindestift	Tornillo Vis	0,80	
13	5100016787	1	Brake valve Bremsventil	Válvula de frenaje Robinet de freinage		
14	5100016788	1	Drive valve Das Antriebsventil	Válvula de mando Soupape d'entraînement		
15	0182738	2	Test fitting Prüfung passend	La prueba que queda Le test ajustant	M16 x 2, 7/16-20 UNC	
16	5100016789	1	Mounting bracket Konsole	Ménsula Support		
17	0010621	3	Washer Scheibe	Arandela Rondelle		
18	5200015174	4	Screw Schraube	Tornillo Vis		
19	0078816	1	Adapter fitting Zwischenverschraubung	Unión con adaptador Raccord intermédiaire		
20	0158574	3	Fitting Verschraubung	Unión Raccord	No.6	
21	0080558	5	Fitting Verschraubung	Unión Raccord		
22	0158572	4	Fitting Verschraubung	Unión Raccord	No.8	
23	5100016790	1	Hydraulic fitting Hydraulikverschraubung	Unión hidráulico Raccord hydraulique	4 x 4	
24	5100016791	1	Exciter valve Erregung des Ventils	Excitador de válvula Excitation de valve		
25	5100016792	4	Coil Spule	Bobina Bobine	12V	

**Hydraulic Manifold**  
**Hydraulikverteiler**  
**Distribuidor Hidráulico**  
**Tubulure Hydraulique**

**RTLx-SC3**

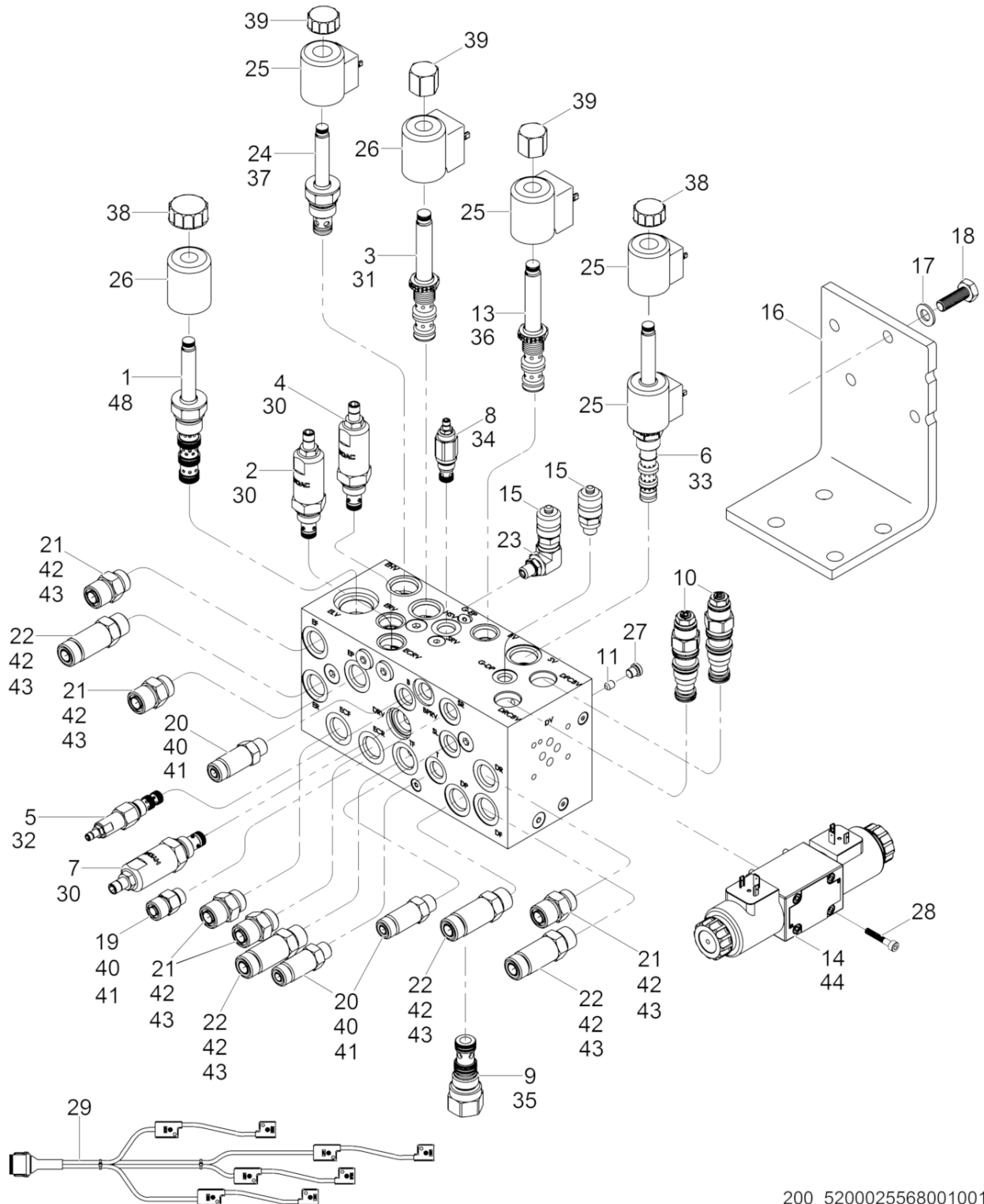

200\_5200025568001001

Ref. Pos.	Part No. Artikel Nr.	Qty. St.	Description Beschreibung	Descripción Description	Measurement./Abm.	Norm
					Torque/Drehm.	Sealant Schmierstoff
26	5100016793	2	Coil Spule	Bobina Bobine	12V	
27	5100016794	9	Plug Stopfen	Tapón Bouchon	No. 2	
28	0011558	4	Cheese head screw Zylinderschraube	Tornillo cilíndrico Vis à tête cylindrique	M5 x 30 10Nm/7ft.lbs	ISO4762
29	5200023703	1				
30	5100016796	3	Seal Kit Dichtungssatz	Juego-empaque Jeu-joint		
31	5100016797	1	Seal Kit Dichtungssatz	Juego-empaque Jeu-joint		
32	5100016798	1	Seal Kit Dichtungssatz	Juego-empaque Jeu-joint		
33	5100016799	1	Seal Kit Dichtungssatz	Juego-empaque Jeu-joint		
34	5100016800	1	Seal Kit Dichtungssatz	Juego-empaque Jeu-joint		
35	5100016801	1	Seal Kit Dichtungssatz	Juego-empaque Jeu-joint		
36	5100016802	1	Seal Kit Dichtungssatz	Juego-empaque Jeu-joint		
37	5100016803	1	Seal Kit Dichtungssatz	Juego-empaque Jeu-joint		
38	5100016804	2	Coil Kit Spule kpl.	Bobina compl. Bobine compl.		
39	5100016805	3	Coil Kit Spule kpl.	Bobina compl. Bobine compl.		
40	0080731	4	O-Ring O-Ring	Anillo-O Joint torique	0,468 x 0,078in	
41	0080736	4	O-Ring O-Ring	Anillo-O Joint torique	0,364 x 0,070in	
42	0080732	9	O-Ring O-Ring	Anillo-O Joint torique	0,644 x 0,087in	
43	0080737	9	O-Ring O-Ring	Anillo-O Joint torique	0,489 x 0,070in	
44	5100016873	1	Seal Kit Dichtungssatz	Juego-empaque Jeu-joint		
45	5100016874	1	Manifold Verteiler	Distribuidor Tubulure		
46	5100016875	8	Plug Stopfen	Tapón Bouchon	No. 4	
47	5100016876	14	Plug Stopfen	Tapón Bouchon	No. 6	
48	5100016795	1	Seal Kit Dichtungssatz	Juego-empaque Jeu-joint		

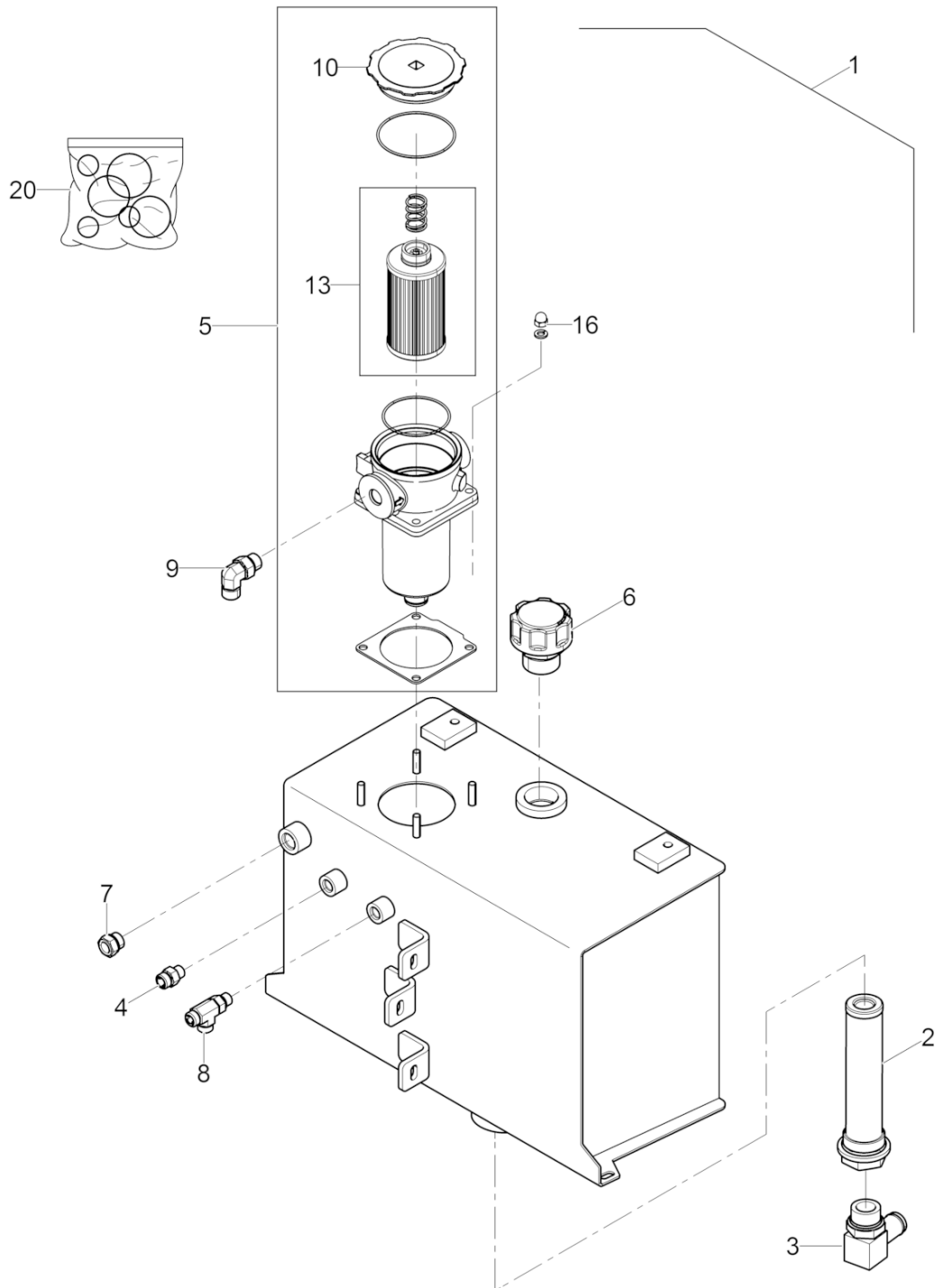

wc\_ex0179971001

Ref. Pos.	Part No. Artikel Nr.	Qty. St.	Description Beschreibung	Descripción Description	Measurement/Abm.	Norm
					Torque/Drehm.	Sealant Schmierstoff
1	5200000844	1	Hydraulic tank Hydrauliktank	Tanque hidráulico Réservoir hydraulique		
2	0182746	1	Suction strainer Saugkorb	Colador Crépine		
3	0182747	1	Barbed fitting Verschraubung mit Widerhaken	Unión dentada Raccord à picot	No.6 x 90	
4	0078816	1	Adapter fitting Zwischenverschraubung	Unión con adaptador Raccord intermédiaire		
5	0182748	1	Return filter Rückleitungsfiter	Filtro de retorno Filtre de retour		
6	5200000845	1	Breather tube Entlüftungskappe	Tapa respiradero Capuchon reniflard		
7	0116236	1	Sightglass Ölschauglas	Mirilla del nivel de aceite Verre-regard d'huile		
8	0083412	1	Fitting Verschraubung	Unión Raccord		
9	0111272	1	Hydraulic elbow fitting Hydraulikrohrkrümmer	Codo hidráulico Coude hydraulique	SAE No.8 x 90	
10	0182750	1	Cover Deckel	Tapa Couvercle		
13	0182752	1	Filter element Filterelement	Elemento del filtro Élément du filtre		
16	0159508	4	Acorn nut Hutmutter	Tuerca Ecrou	M10	
20	0182733	1	Gasket & O-Ring Set Dichtungs- u. O-Ringsatz	Juego de juntas/anillos-O Jeu de joints		

**Transmitter Module  
Sender  
Transmisor  
Transmetteur**

**RTLx-SC3**

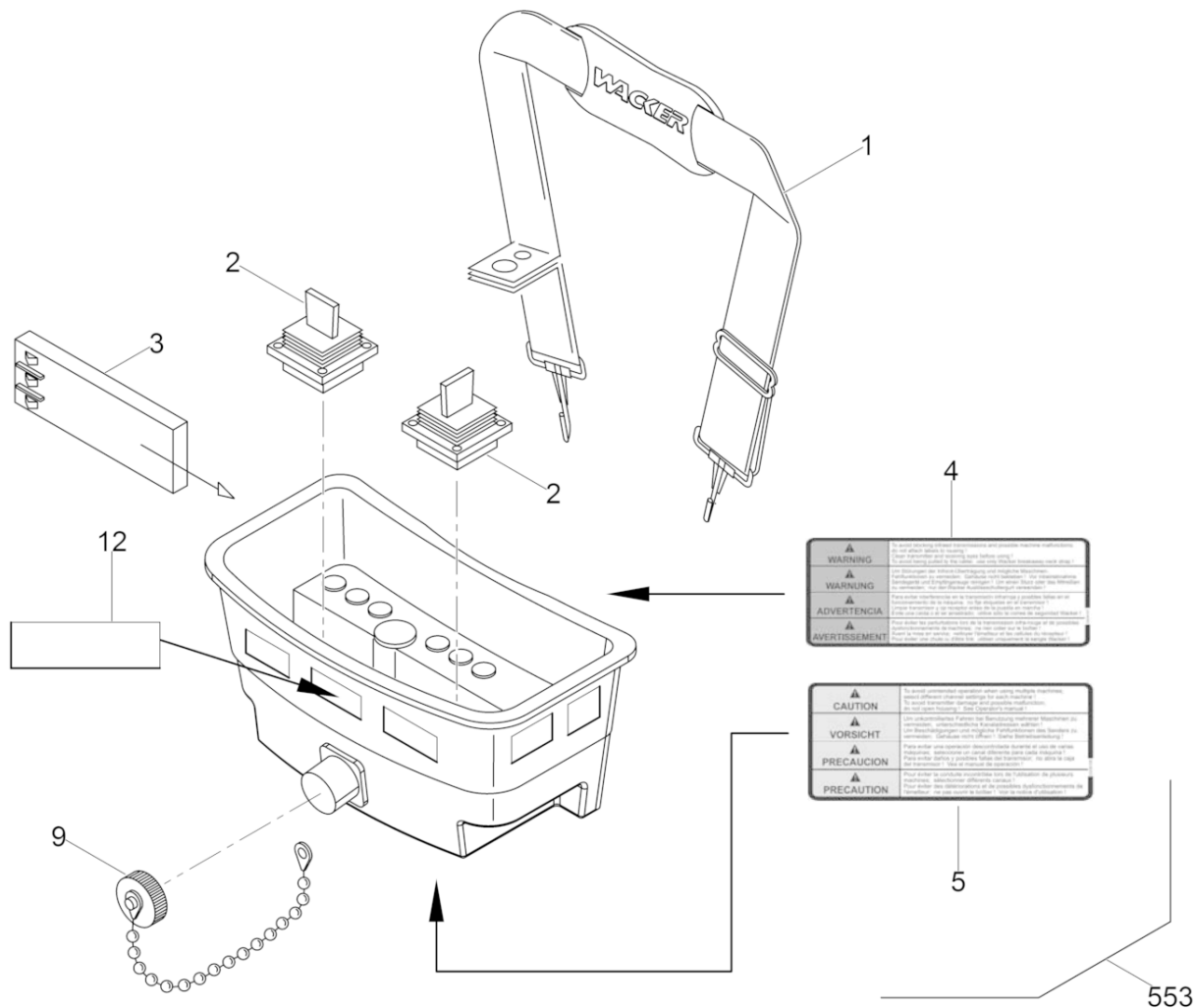

wc\_ex0165514001

Ref. Pos.	Part No. Artikel Nr.	Qty. St.	Description Beschreibung	Descripción Description	Measurem./Abm.	Norm
					Torque/Drehm.	Sealant Schmierstoff
1	0114783	1	Band Band	Cinta Ruban		
2	0176115	2	Joystick cpl. Steuerhebel kpl.	Palanca direccional compl. Commutateur à tige compl.		
3	0210156	1	Battery Akku	Batería Accumalteur		
4	0209157	1	Label-warning Aufkleber-Warnung	Calcomania-Advertencia Autocollant-Avertissement		
5	0209158	1	Instruction Label Aufkleber-Hinweis	Calcomanía-Indicación Autocollant avec Indication		
6	0209760	1	Battery charger Ladegerät	Cargador par batería Chargeur de batteries		
7	0209763	1	Power cable Anschlusskabel	Cable de alimentación Cable d'alimentation		
8	0209761	1	Mains plug Steckernetzteil	Enchufe de alimentación Mains plug		
9	0117184	1	Cap Kappe	Tapa Couvercle		
10	0213091	1	Battery charger Ladegerät	Cargador par batería Chargeur de batteries		
11	0209762	1	Mains plug Steckeradapter-Set	Enchufe de alimentación Mains plug		
12	5200000726	1	Cover Deckel	Tapa Couvercle		
553	0165514	1	Transmitter module Sender	Transmisor Transmetteur		

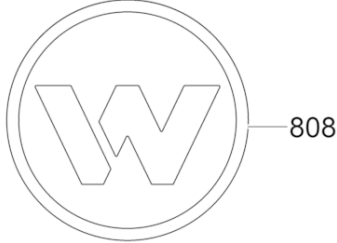

CHANGEL LABELS:  
MARK THE OPERATING CHANNEL ON BOTH TRANSMITTER AND RECEIVER. REPLACE ORIGINAL LABEL WITH NEW CHANNELS AND CHANGE.

KANALUMKLEBER:  
BEZEICHNEN SIE DEN BETRIEBSKANAL AUF BEIDEN TRANSMITTER UND EMPFÄNGER. ERSETZEN SIE DAS URSPRÜNGLICHE KANALUMKLEBER MIT DEN NEUEN KANÄLEN UND VERÄNDERN SIE DIE KANÄLE.

CALCOMANIAS PARA CANAL:  
MARQUE EL CANAL DE CONTROL, TANTO EN EL TRANSMISOR COMO EN EL RECEPTOR. REEMPLAZE LAS CALCOMANIAS ORIGINALES POR LAS CALCOMANIAS NUEVAS CUANDO CAMBIE LOS CANALES.

AUTOCOLLANT POUR CANAL:  
MARQUEZ LE CANAL DE CONTRÔLE, TANT AU ÉMETTEUR QU'AU RÉCEPTEUR. REMPLACEZ L'AUTOCOLLANT ORIGINAL PAR UN AUTOCOLLANT NOUVEAU QUAND LES CANAUX SONT CHANGÉS.

1	1	9	9
2	2	0	0
3	3	A	A
4	4	B	B
5	5	C	C
6	6	D	D
7	7	E	E
8	8	F	F

808

807

1301

ULTRA LOW SULFUR FUEL ONLY.  
NUR ULTRANIEDRIGEN SCHWEFELKRAFTSTOFF.  
SOLAMENTE COMBUSTIBLE DE ULTRABAJO CONTENIDO DE AZUFRE.  
SEULEMENT CARBURANT DE SOUFRE ULTRA BAS.

816

801—RTSC3  
802—WACKER  
NEUSON

200\_5200019232100015



Ref. Pos.	Part No. Artikel Nr.	Qty. St.	Description Beschreibung	Descripción Description	Measurement./Abm.	Norm
					Torque/Drehm.	Sealant Schmierstoff
801	5200023102	2	Label Aufkleber	Calcomania Autocollant		
802	0222136	2	Label-logo Aufkleber, Logo	Calcomanía-logotipo Autocollant - logo	100 OD	
805	5200022195	1	Label sheet Aufkleberblatt	Hoja de calcomanias Feuille d'autocollants		
807	0171055	1	Label Aufkleber	Calcomania Autocollant		
808	0222087	2	Label Symbol Aufkleber Symbol	Calcomania Símbololo Autocollant Symbole	120 OD	
816	0177416	1	Label-diesel fuel Aufkleber	Calcomania Autocollant		
1301	5200022197	1	Label sheet-EU Aufkleberblatt-EU	Hoja de calcomanias-EU Feuille d'autocollants-EU		





**WACKER  
NEUSON**

**Engine-Kohler  
Kohler-Motor  
Motor Kohler  
Moteur Kohler**



200\_5200015979001001

Ref. Pos.	Part No. Artikel Nr.	Qty. St.	Description Beschreibung	Descripción Description	Measurement./Abm.	Norm
					Torque/Drehm.	Sealant Schmierstoff
1	0160365	1	Crankshaft Kurbelwelle	Cigüeñal Vilebrequin		
2	0159357	1	Pin Stift	Espiga Goupille		
3	0159260	1	Woodruff key Woodruffkeil	Chaveta Woodruff Clavette Woodruff		
4	0159454	3	Plug (threaded) Schraubverschluß	Tapón roscado Bouchon		
5	0159261	1	Square key Passfeder	Chaveta Clavette		

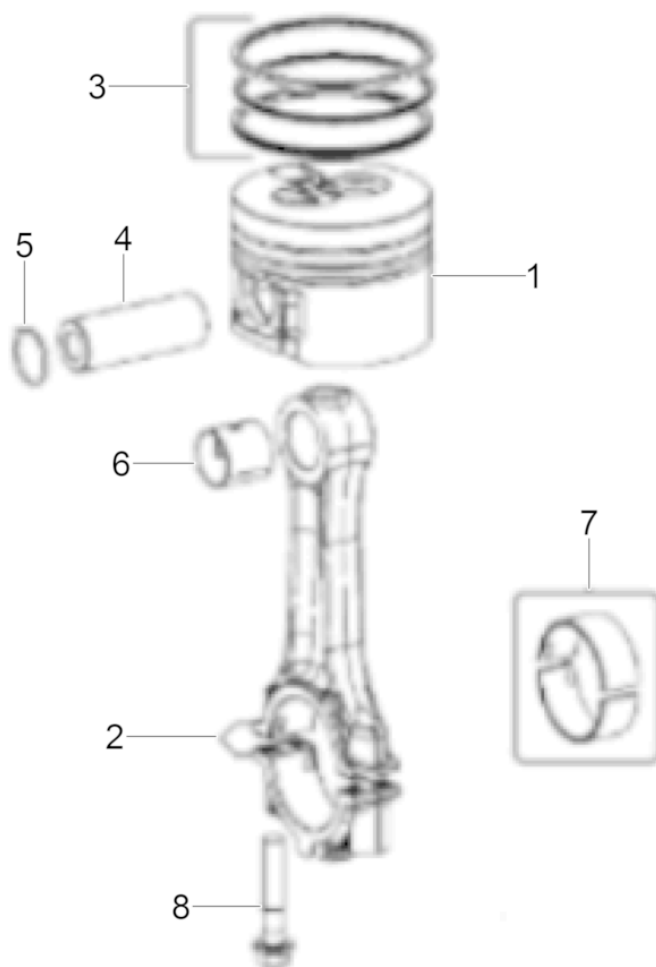

200\_5200015979001002

Ref. Pos.	Part No. Artikel Nr.	Qty. St.	Description Beschreibung	Descripción Description	Measurem./Abm.	Norm
					Torque/Drehm.	Sealant Schmierstoff
1	0160375	3	Set Of Piston Kolbensatz	Juego de Pistón Jeu de Piston		
1	0160376	3	Set Of Piston Kolbensatz	Juego de Pistón Jeu de Piston		
1	0160377	3	Set Of Piston Kolbensatz	Juego de Pistón Jeu de Piston		
2	0160367	3	Connecting rod Pleuel	Biela Bielle		
3	0160383	2	Piston Ring Set Kolbenringsatz	Juego de cubo levantador Jeu de moyeu de levage		
3	0160384	2	Kit-lift ring Ringsatz	Juego de cubo levantador Jeu de moyeu de levage		
3	0160385	2	Kit-lift ring Ringsatz	Juego de cubo levantador Jeu de moyeu de levage		
4	0215523	3	Piston pin Kolbenbolzen	Perno de pistón Axe de piston		
5	0215477	6	Retaining ring Sicherungsring	Anillo de retención Bague d'arrêt		
6	0160368	2	Bushing Buchse	Buje Douille		
7	0155689	2	Bearing Lagerschalen	Rodamiento Roulement		
7	0155690	2	Bearing Pleuellagerangen	Rodamiento Roulement		
7	0155691	2	Bearing Pleuellagerangen	Rodamiento Roulement		
8	0084175	4	Screw Schraube	Tornillo Vis		



200\_5200015979001003



Ref. Pos.	Part No. Artikel Nr.	Qty. St.	Description Beschreibung	Descripción Description	Measurement./Abm.	Norm
					Torque/Drehm.	Sealant Schmierstoff
1	0159485	1	Flywheel compl. Schwungrad kpl.	Volante compl. Volant compl.		
2	0155692	1	Connecting rod Pleuel	Biela Bielle		
3	0160188	5	Bolt Bolzen	Perno Boulon		
4	0159258	1	Rotor Rotor	Rotor Rotor		

**Pulley cpl.**  
**Scheibensatz**  
**Conjunto Cabrestante**  
**Ensemble Poulie**

**RTLx-SC3**

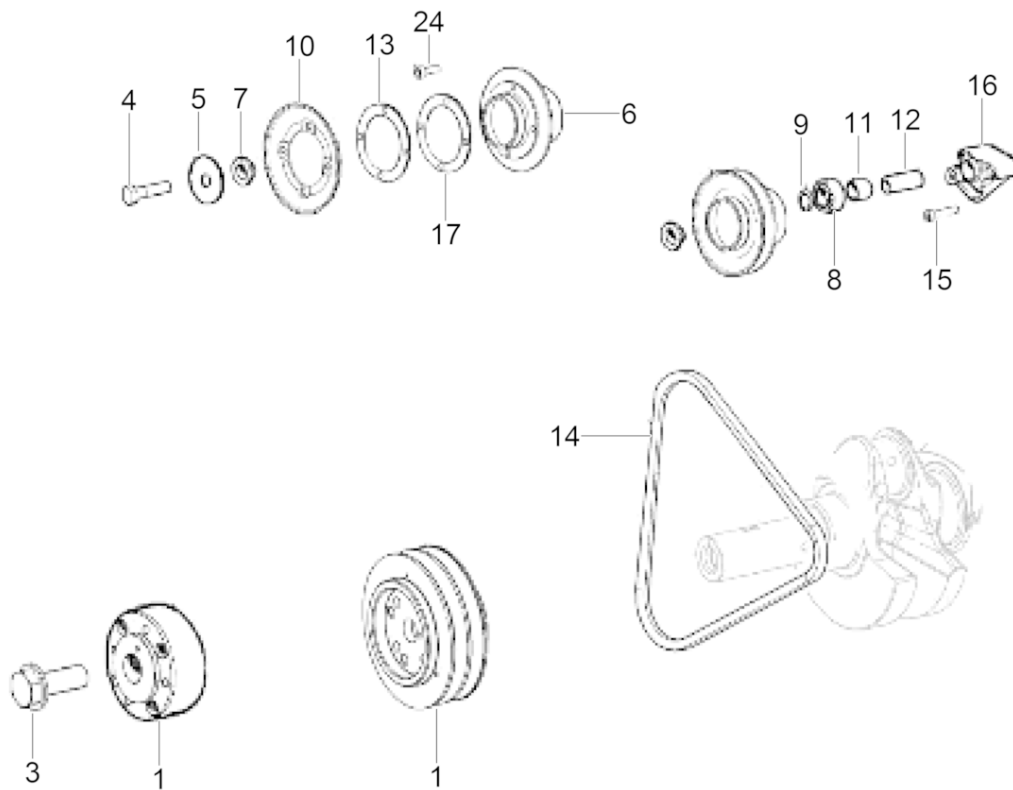

200\_5200015979001004

Ref. Pos.	Part No. Artikel Nr.	Qty. St.	Description Beschreibung	Descripción Description	Measurement./Abm.	Norm
					Torque/Drehm.	Sealant Schmierstoff
1	0155723	1	Crankshaft pulley Scheibe	Disco Rondelle		
3	0126935	1	Bolt Bolzen	Perno Boulon		
4	0159490	1	Bolt Bolzen	Perno Boulon	M8x1.25x90	
5	0159346	1	Washer Scheibe	Disco Rondelle		
6	0159345	1	Pulley cpl. Konsole kpl.	Consola cpl. Console cpl.		
6	5200023964	1	Pulley Scheibe	Polea Poulie		
7	0159347	1	Washer Scheibe	Disco Rondelle		
8	0082135	2	Bearing Lager	Cojinete Palier		
9	0159241	2	Retaining ring Sicherungsring	Anillo de retención Bague d'arrêt		
10	0207987	1	V-belt pulley half Riemenscheibenhälfte	Semi polea en V Flanc de poulie à courroie		
11	0159277	1	Spacer Abstandsstück	Espaciador Pièce d'écartement		
12	0159489	1	Pin Stift	Espiga Goupille	63,5	
13	0207988	2	Distance washer Abstandsscheibe	Arandela distanciador Rondelle intermédiaire	0,5	
14	0159262	1	Belt Riemen	Correa Courroie		
15	0083026	3	Screw Schraube	Tornillo Vis	M8x35	
16	0159448	1	Console Konsole	Consola Console		
17	0207989	4	Distance washer Abstandsscheibe	Arandela distanciador Rondelle intermédiaire	1,0	
24	0159475	4	Screw Schraube	tornillo vis		

Cylinder Head  
 Zylinderkopf  
 Culata  
 Culasse

RTLx-SC3

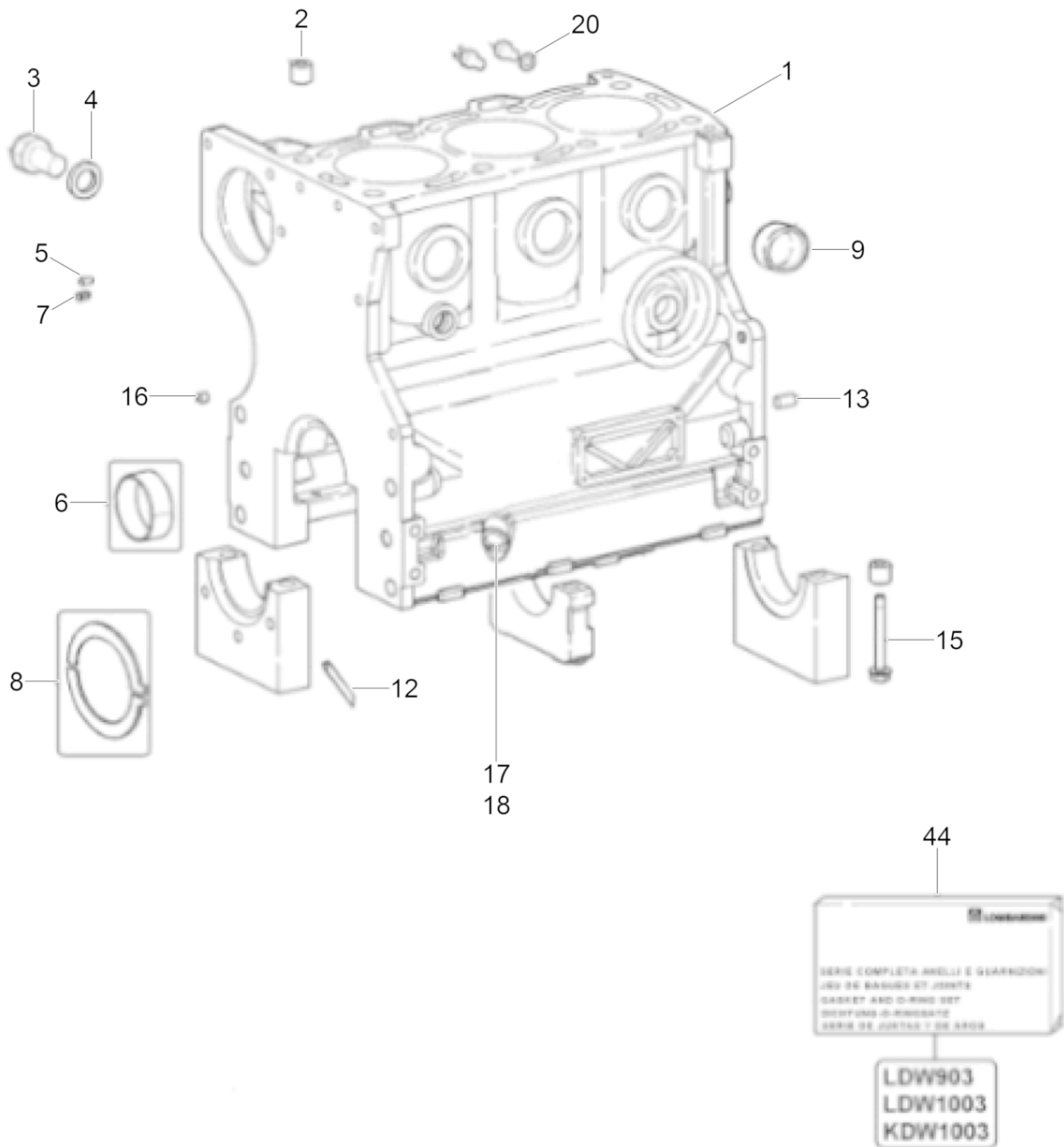

200\_5200015979001005

Ref. Pos.	Part No. Artikel Nr.	Qty. St.	Description Beschreibung	Descripción Description	Measurem./Abm.	Norm
					Torque/Drehm.	Sealant Schmierstoff
1	0160388	1	Cylinder head Zylinderkopf	Culata Culasse		
5	0159449	2	Plug Stopfen	Enchufe Prise		
6	0159318	3	Spark arrester Funkenfänger	Parachispas Pare-étincelles		
7	0215524	2	Lifting point Aufhängung	Punto para itar Suspension		
8	0084156	1	Screw Schraube	Tornillo Vis		
9	0159479	8	Bolt Bolzen	Perno Boulon		
10	0159350	8	Washer Scheibe	Arandela Rondelle		
11	0159231	1	O-ring O-ring	Anillo en forma de o Joint torique		
13	0159311	1	Bracket Halter	Soporte Équerre		
14	0159254	1	Bolt Bolzen	Perno Boulon		
15	0082292	1	Washer Scheibe	Arandela Rondelle		
17	0159303	6	Valve guide Ventilführung	Guía de válvula Guide de soupape		
18	0160381	3	Seat-valve, intake Sitz des Einlassventils	Asiento de la válvula de admisión Siège de la soupape		
19	0160382	3	Seat-valve, exhaust Sitz des Auslassventils	Asiento de la válvula de escape Siège de la soupape		
23	0159285	3	Nut Mutter	Tuerca Ecrou		
24	0215494	9	Spacer Abstandsstück	Espaciador Pièce d'écartement		
25	0160380	3	Precombustion chamber Vorkammer	Cámara de precombustión Préchambre		
26	0160369	1	Cylinder head gasket (1) notch Zylinderkopfdichtung mit Schlitz (1)	Junta de culata del cilindro con entalladura (1) Joint de culasse de cylindre a		
26	0160370	1	Cylinder head gasket (2) notch Zylinderkopfdichtung mit Schlitz (2)	Junta de culata del cilindro con entalladura (2) Joint de culasse de cylindre a		
26	0160371	1	Cylinder head gasket (3) notch Zylinderkopfdichtung mit Schlitz (3)	Junta de culata del cilindro con entalladura (3) Joint de culasse de cylindre a		
33	5200009477	1	Gasket set Dichtungssatz	Juego de juntas Jeu de joints		

**Crankcase**  
**Kurbelgehäuse**  
**Cárter**  
**Carter**

**RTLx-SC3**

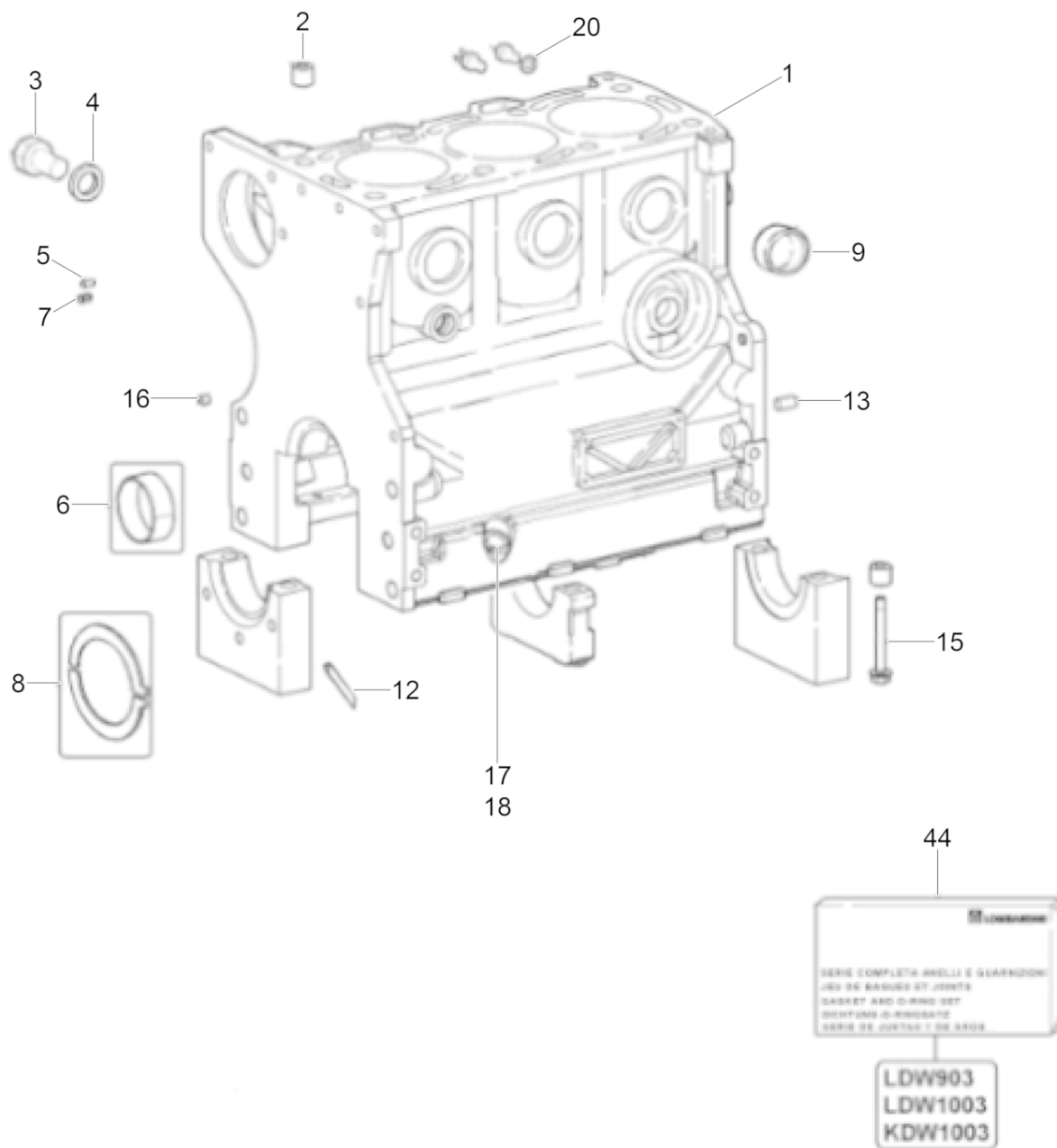

200\_5200015979001005

Ref. Pos.	Part No. Artikel Nr.	Qty. St.	Description Beschreibung	Descripción Description	Measurem./Abm.	Norm
					Torque/Drehm.	Sealant Schmierstoff
1	0210344	1	Crankcase Kurbelgehäuse	Cárter Carter		
2	0159257	2	Sleeve Hülse	Collar Douille		
3	0206229	1	Screw Schraube	Tornillo Vis		
4	0082184	1	Ring seal Dichtring	Anillo sellador Rondelle à étancher		
5	0215522	1	Pin Stift	Espiga Goupille		
6	0155702	3	Bearing Lager	Cojinete Palier		
6	0155703	3	Bearing Lager	Cojinete Palier		
6	0155704	3	Bearing Lager	Cojinete Palier		
8	0159486	2	Washer Scheibe	Disco Rondelle		
8	0159487	2	Disc Scheibe	Disco Disque		
8	0159488	2	Disc Scheibe	Disco Disque		
9	0082335	4	Plug (threaded) Schraubverschluß	Tapón roscado Bouchon		
12	0159288	4	Gasket Dichtung	Junta Joint		
13	0159360	2	Dowel pin Paßstift	Espiga Cheville		
15	0159480	8	Screw Schraube	Tornillo Vis		
16	0159456	1	Plug Stopfen	Tapón Bouchon		
17	0159299	1	Washer Scheibe	Disco Rondelle		
18	0215530	1	Plug Stopfen	Enchufe Prise		
20	0082183	1	Ring seal Dichtring	Anillo sellador Rondelle à étancher		
44	0159397	1	Crankcase Gasket Set Dichtungssatz, Kurbelgehäuse	Juego de juntas, cárter Jeu de joints, carter		

Cylinder Head Cover  
Zylinderkopfhaube  
Tapa del Cilindro  
Couvercle Supérieur

RTLx-SC3

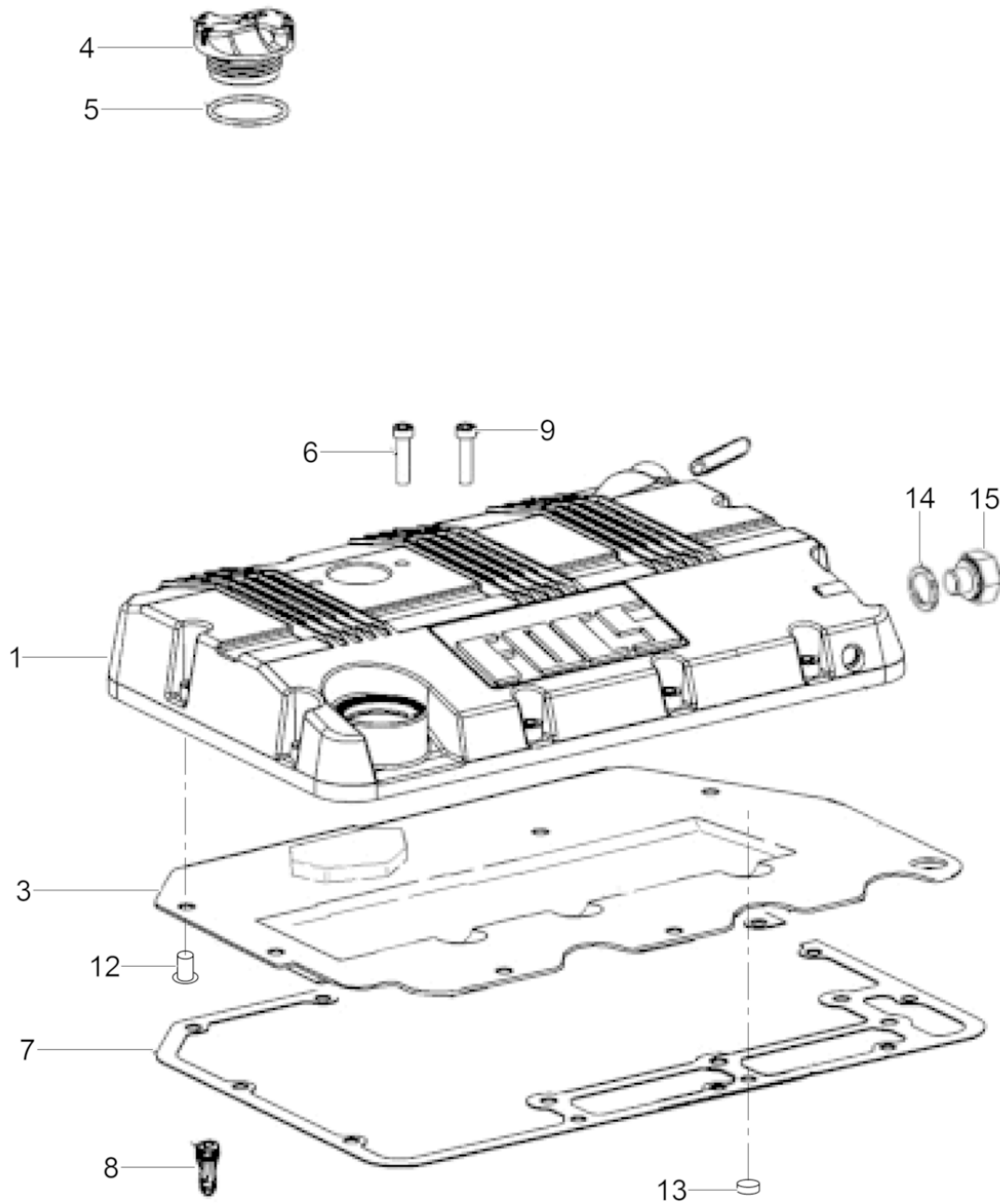

200\_5200015979001007



Ref. Pos.	Part No. Artikel Nr.	Qty. St.	Description Beschreibung	Descripción Description	Measurement./Abm.	Norm
					Torque/Drehm.	Sealant Schmierstoff
1	0210346	1	Valve cover Ventilhaube	Tapa de válvula Couvercle de soupape		
3	0159305	1	Baffle Leitblech	Deflector Déflecteur		
4	0210347	1	Cap Kappe	Tapa Couvercle		
5	0206208	1	O-ring O-ring	Anillo en forma de o Joint torique		
6	5200009533	10	Screw Schraube	Tornillo Vis	M10 x 30	
7	0160205	1	Gasket Dichtung	Junta Joint		
8	0159308	1	Connector Anschlußteil	Conector Connexion		
9	0215544	2	Screw Schraube	Tornillo Vis		
12	5200015519	9	Rivet Niet	Remache Rivet		
13	0159455	1	Push-in plug Stopfen	Tapón Bouchon		
14	0082184	1	Ring seal Dichtring	Anillo sellador Rondelle à étancher		
15	0082331	1	Plug (threaded) Schraubverschluß	Tapón roscado Bouchon		

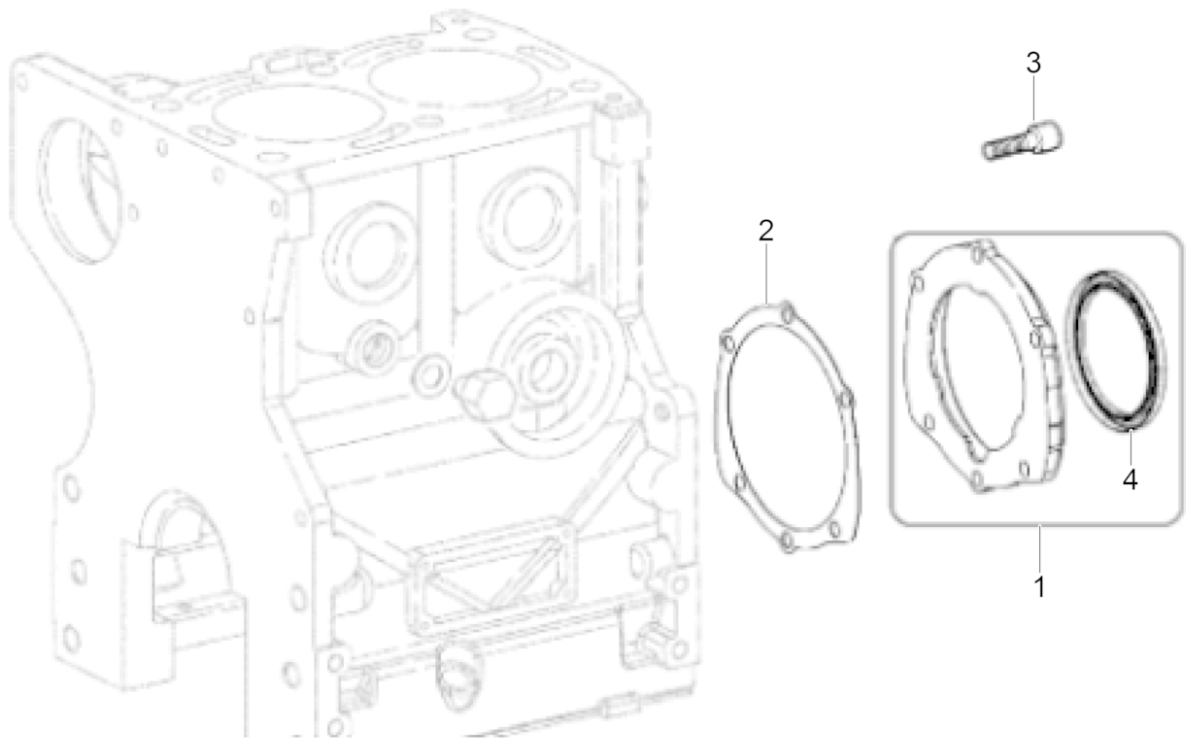

200\_5200015979001008

Ref. Pos.	Part No. Artikel Nr.	Qty. St.	Description Beschreibung	Descripción Description	Measurem./Abm.	Norm
					Torque/Drehm.	Sealant Schmierstoff
1	0159281	1	Flange Cover Blindflansch	Palanca de Cubierta Semelle		
2	0159296	1	Gasket Dichtung	Junta Joint		
3	5200023965	6	Screw Schraube	Tornillo Vis		
4	0103314	1	Ring seal Wellendichtring	Anillo sellador Rondelle à étancher		

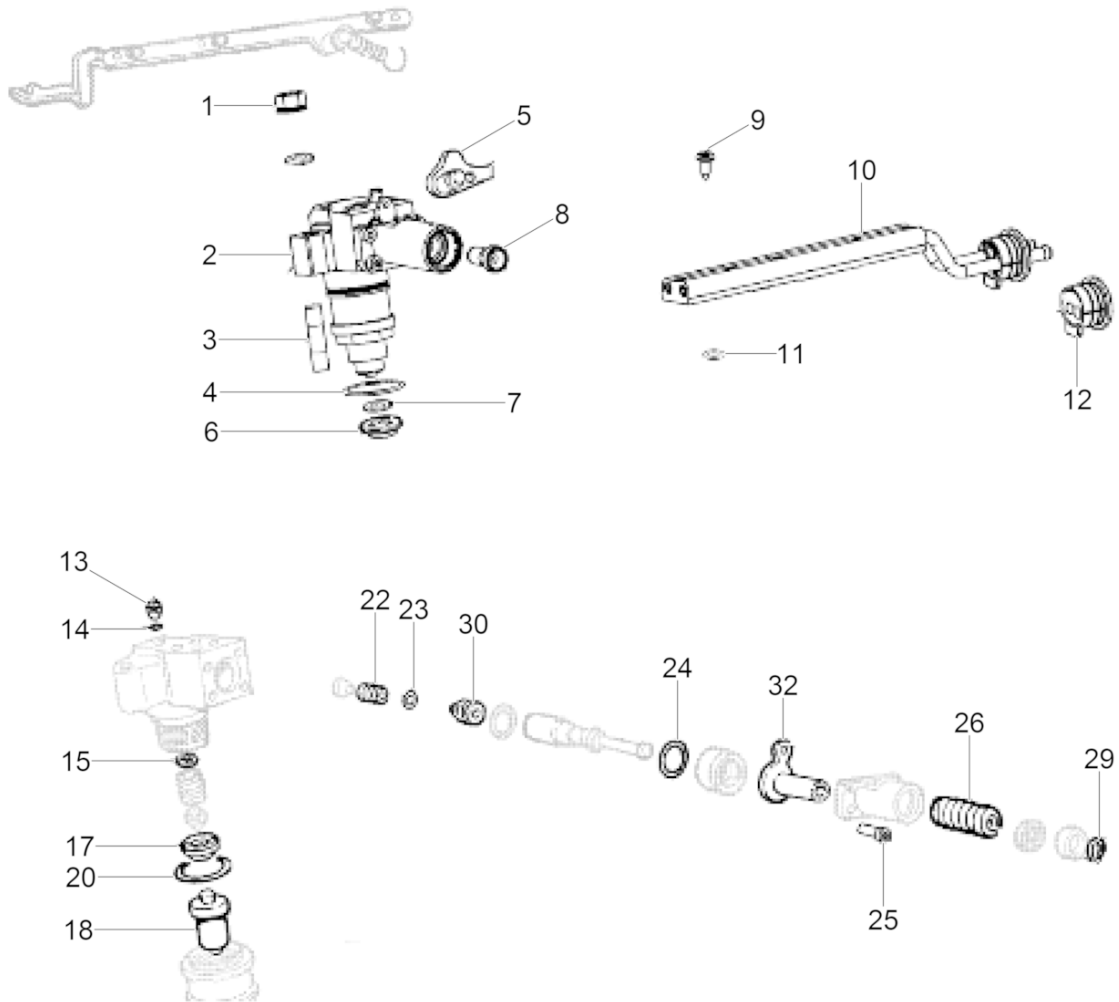

200\_5200015979001009

Ref. Pos.	Part No. Artikel Nr.	Qty. St.	Description Beschreibung	Descripción Description	Measurem./Abm.	Norm
					Torque/Drehm.	Sealant Schmierstoff
1	0063700	6	Flange nut Flanschmutter	Tuerca de reborde Ecrou de bride		
2	0160379	3	Injection pump Einspritzpumpe	Bomba de inyección Pompe à injection		
3	5200009479	6	Stud Gewindebolzen	Perno prisionero Goujon		
4	0159233	2	O-Ring O-Ring	Anillo-O Joint torique		
5	0159325	1	Plate Platte	Placa Plaque		
7	0159300	3	Washer Scheibe	Disco Rondelle		
9	0159473	6	Screw Schraube	Tornillo Vis		
10	0159459	1	Pipe Rohr	Tubo Conduit		
11	0159237	2	Ring Ring	Anillo Anneau		
12	0160209	1	Gasket Dichtung	Junta de estanqueidad Garniture		
13	0160391	2	Back pressure valve Rückschlagventil	Válvula de retención Soupape de retenue		
14	0159302	2	Gasket Dichtung	Junta de estanqueidad Garniture		
15	5200009480	1	Spacer Abstandsstück	Espaciador Entretoise	2,00	
15	5200009490	1	Spacer Abstandsstück	Espaciador Entretoise	2,00	
15	5200009489	1	Spacer Abstandsstück	Espaciador Entretoise	2,00	
15	5200009488	1	Spacer Abstandsstück	Espaciador Entretoise	1,2	
15	5200009487	1	Spacer Abstandsstück	Espaciador Entretoise	2,00	
15	5200009486	1	Spacer Abstandsstück	Espaciador Entretoise	2,00	
15	5200009485	1	Spacer Abstandsstück	Espaciador Entretoise	2,00	
15	5200009484	1	Spacer Abstandsstück	Espaciador Entretoise	1,40	
15	5200009482	1	Spacer Abstandsstück	Espaciador Entretoise	1,70	
15	5200009481	1	Spacer Abstandsstück	Espaciador Entretoise	1,80	
17	0159278	2	Spacer Abstandsstück	Espaciador Pièce d'écartement		
18	0155710	2	Jet Düse	Chicler Gicleur		
20	0159238	2	O-ring O-Ring	Anillo-O Bague-O		

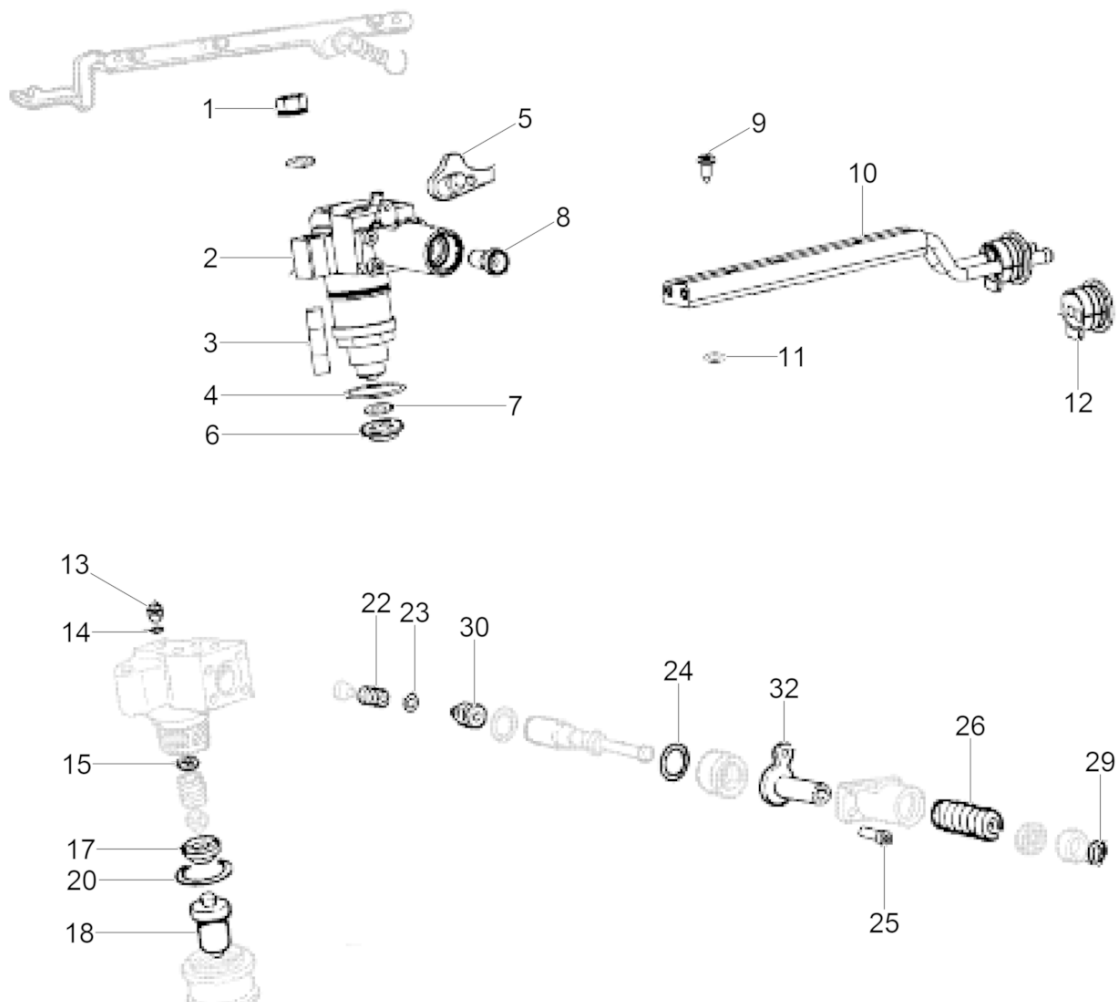

200\_5200015979001009

Ref. Pos.	Part No. Artikel Nr.	Qty. St.	Description Beschreibung	Descripción Description	Measurement./Abm.	Norm
					Torque/Drehm.	Sealant Schmierstoff
22	5200009491	2	Spring Feder	Resorte Ressort		
23	5200009492	2	Gasket Dichtung	Junta Joint		
24	0159236	2	Ring Ring	Anillo Anneau		
25	0159471	4	Screw Schraube	Tornillo Vis		
26	0159317	2	Spring Feder	Resorte Ressort		
29	0159242	2	Clamp Klemme	Abrazadera Pince		
30	5200015520	2	Pressure valve Überdruckventil	Válvula de sobrepresión Soupape de surpression		
32	0159309	2	Shim Ausgleichscheibe	Laminita Cale		

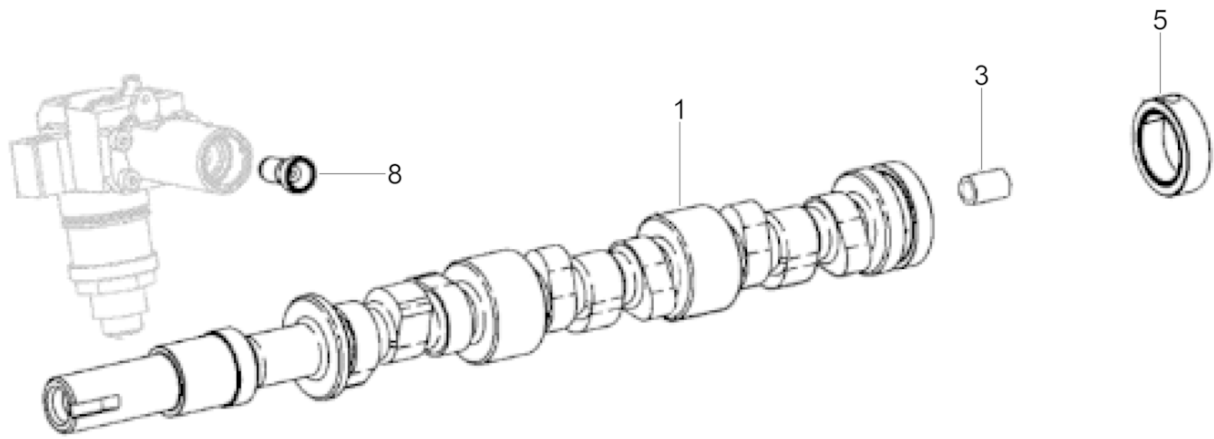

200\_5200015979001010



Ref. Pos.	Part No. Artikel Nr.	Qty. St.	Description Beschreibung	Descripción Description	Measurement./Abm.	Norm
					Torque/Drehm.	Sealant Schmierstoff
1	0160751	1	Camshaft Nockenwelle	Arbol de levas Arbre à cames		
3	0160752	1	Sleeve Hülse	Manguito Douille		
5	0160753	1	Injector cam Einspritznocken	Leva inyectora Came d'injection		
8	0159246	2	Push rod (valve lifter) Stoßstange	Levantaválvula Poussoir de soupape		

**Rocker Arms/Valves**  
**Kipphebel/Ventile**  
**Balancines/Válvulas**  
**Culbuteurs/Soupapes**

**RTLx-SC3**

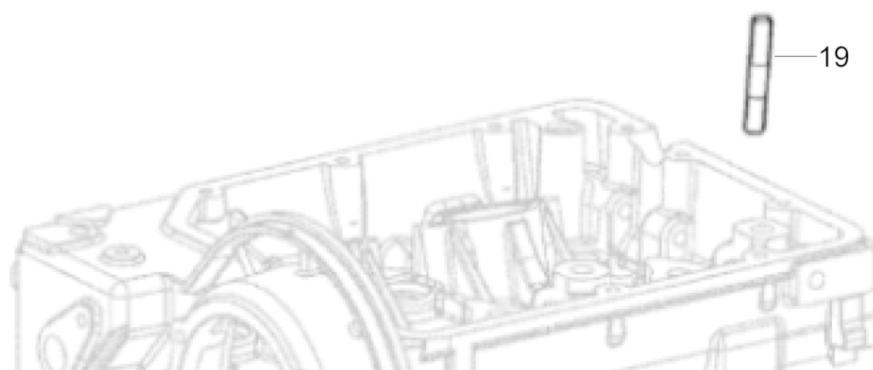
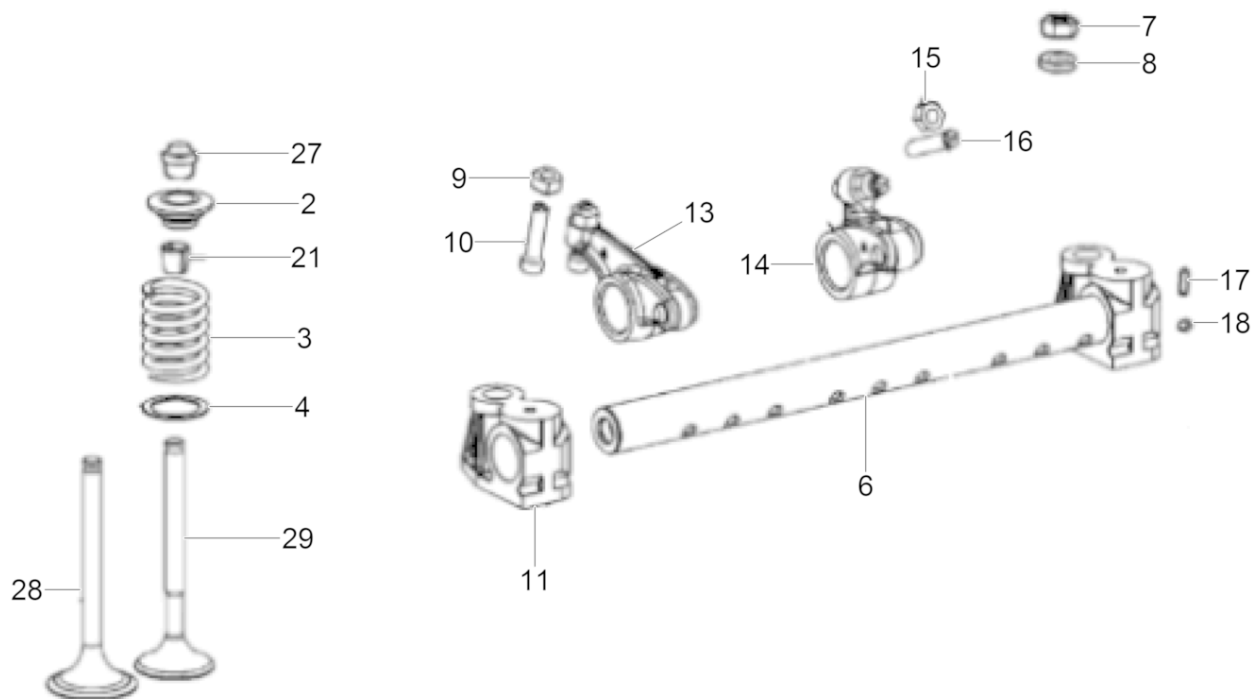

200\_5200015979001011

Ref. Pos.	Part No. Artikel Nr.	Qty. St.	Description Beschreibung	Descripción Description	Measurement/Abm.	Norm
					Torque/Drehm.	Sealant Schmierstoff
2	0159328	4	Spring Housing Federgehäuse	Carcasa de Resorte Logement du Ressort		
3	0160373	6	Spring Ventilfeder	Resorte Ressort		
4	0159351	6	Washer Scheibe	Disco Rondelle		
6	0155696	1	Rocker arm cpl. Kipphebel kpl.	Balancín compl. Culbuteur compl.		
6	0160218	1	Rocker arm shaft Kipphebelwelle	Eje del balancín Arbre du culbuteur		
7	0083011	4	Nut Mutter	Tuerca Ecrou		
8	0159350	4	Washer Scheibe	Arandela Rondelle		
9	0159272	1	Nut Mutter	Tuerca Écrou		
10	0159482	1	Screw Schraube	Tornillo Vis		
11	5200009458	4	Shaft support Kipphebelbolzenkonsole	Soporte del eje de balancín Support de l'arbre de bascule		
13	0159248	6	Rocker arm Kipphebel	Balancín Culbuteur		
14	0159249	3	Rocker arm injector Kipphebel Einspritzdüse	Inyector de balancines L'injecteur de culbuteur		
15	0159275	1	Nut Mutter	Tuerca Ecrou		
16	0159483	1	Threaded bolt Gewindebolzen	Perno roscado Boulon fileté		
17	0159443	1	Pin Stift	Espiga Goupille		
18	5200009500	2	Plug Stopfen	Tapón Bouchon		
19	0159333	4	Threaded bolt Gewindebolzen	Perno roscado Boulon fileté		
21	5200015522	12	Locking ring Klemmring	Anillo de sujeción Anneau serrure		
27	0159297	6	Gasket Dichtung	Junta Joint		
28	0160390	3	Intake valve Einlaßventil	Válvula de admisión Soupape d'admission		
29	0160392	3	Outlet valve Auslaßventil	Válvula de escape Soupape d'échappement		

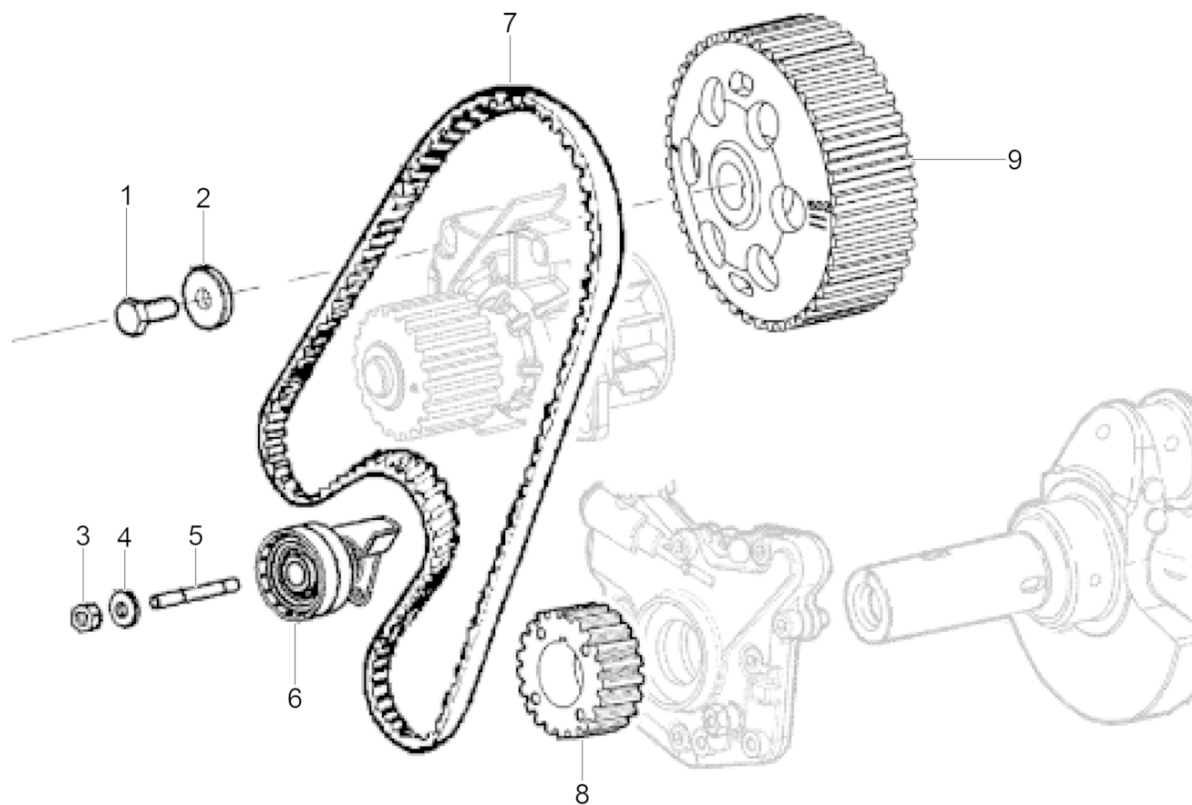

200\_5200015979001012

Ref. Pos.	Part No. Artikel Nr.	Qty. St.	Description Beschreibung	Descripción Description	Measurement./Abm.	Norm
					Torque/Drehm.	Sealant Schmierstoff
1	0159481	1	Screw Schraube	Tornillo Vis		
2	0159349	1	Washer Scheibe	Disco Rondelle		
3	0083011	1	Nut Mutter	Tuerca Ecrou		
4	0159334	1	Threaded bolt Gewindebolzen	Perno roscado Boulon fileté		
5	0159334	1	Threaded bolt Gewindebolzen	Perno roscado Boulon fileté		
6	0159284	1	Tensioner pulley Spannrolle	Polea tensora Poulie de tension		
7	0155697	1	Timing belt Synchronriemen	Correa de sincronización Courroie de synchronisation		
8	0159336	1	V-belt pulley Riemenscheibe	Polea Poulie		
9	0159338	1	V-belt pulley Riemenscheibe	Polea Poulie		

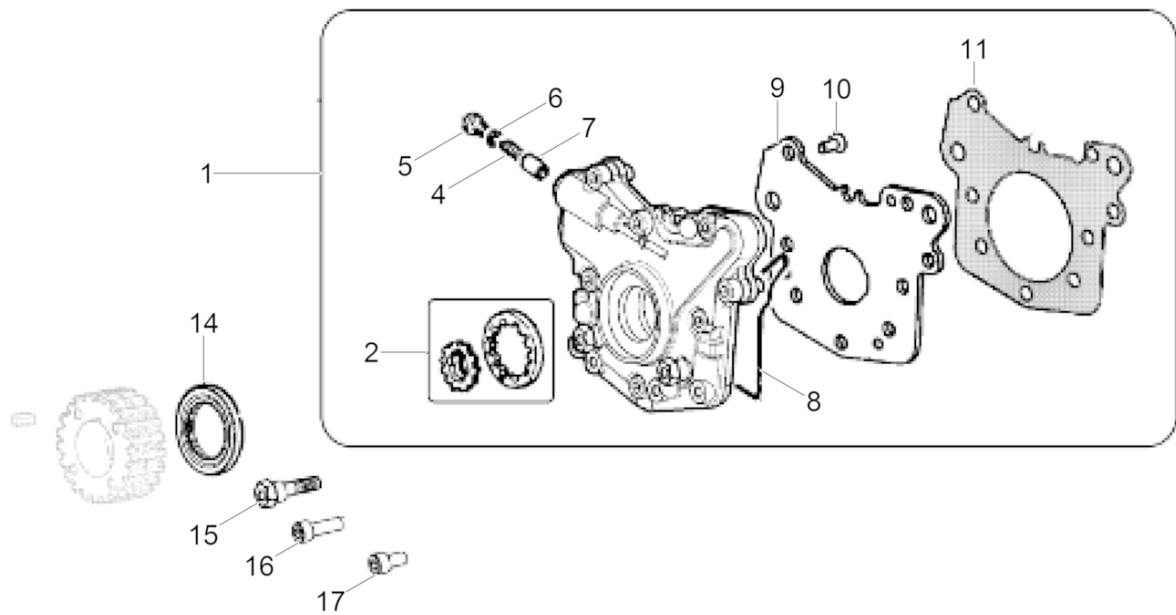

200\_5200015979001013

Ref. Pos.	Part No. Artikel Nr.	Qty. St.	Description Beschreibung	Descripción Description	Measurement/Abm.	Norm
					Torque/Drehm.	Sealant Schmierstoff
1	0155735	1	Oil pump cpl. Ölpumpe kpl.	Bomba de aceite compl. Pompe à huile compl.		
2	5200009456	1	Rotor Rotor	Rotor Rotor		
4	0159312	1	Spring Feder	Resorte Ressort		
5	0159450	1	Screw Locking Schraubverschluß	Cierre Roscada Fermeture de Vissage		
6	0082184	1	Ring seal Dichtring	Anillo sellador Rondelle à étancher		
7	0159330	1	Rod Stange	Varilla Tige		
8	0160178	1	O-Ring O-Ring	Anillo-O Joint torique		
10	0159478	3	Screw Schraube	Tornillo Vis		
11	0215709	1	Gasket Dichtung	Junta de estanqueidad Garniture		
14	0155734	1	Ring seal Dichtungsring	Anillo sellador Rondelle à étancher		
15	0159484	2	Screw Schraube	Tornillo Vis		
16	0215479	1	Hexagonal head cap screw Sechskantschraube	Tornillo hexagonal Vis à tête hexagonale		
17	0084169	6	Screw Schraube	tornillo vis		

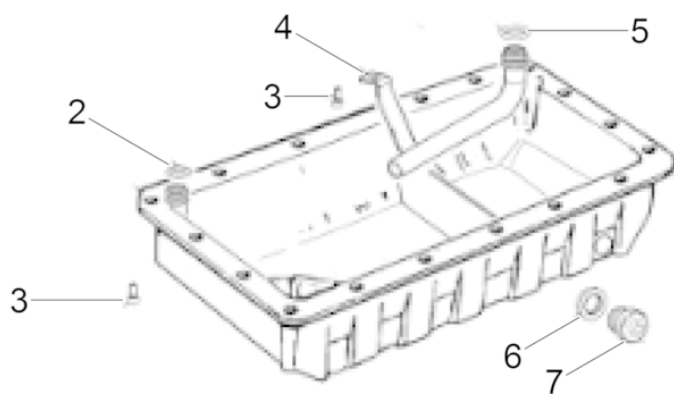
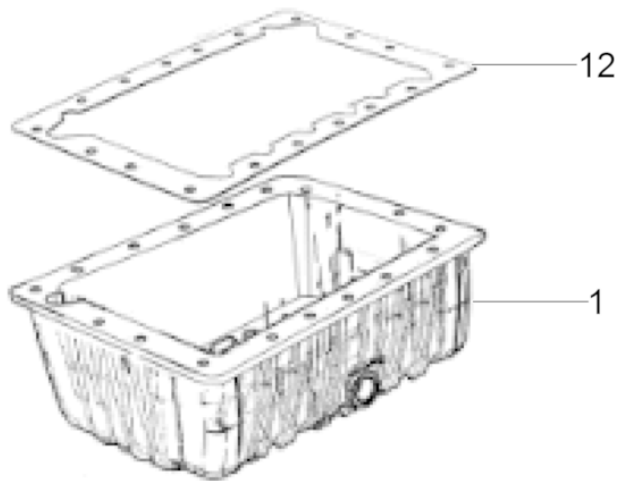

200\_5200015979001014



Ref. Pos.	Part No. Artikel Nr.	Qty. St.	Description Beschreibung	Descripción Description	Measurement./Abm.	Norm
					Torque/Drehm.	Sealant Schmierstoff
1	0155738	1	Oil pan Ölwanne	Colector de aceite Cuvette-carter à huile		
2	0159228	1	Oil Seal Öldichtung	Junta de Aceite Joint D'Huile		
3	0159253	19	Bolt Bolzen	Perno Boulon		
4	0155737	1	Hose Schlauch	Manguera Tuyau		
5	0159235	1	O-Ring O-Ring	Anillo-O Joint torique		
6	0159568	2	Washer Scheibe	Arandela Rondelle		
11	0159452	2	Plug Stopfen	Tapón Bouchon	M18	
12	0159291	1	Gasket Dichtung	Junta Joint		

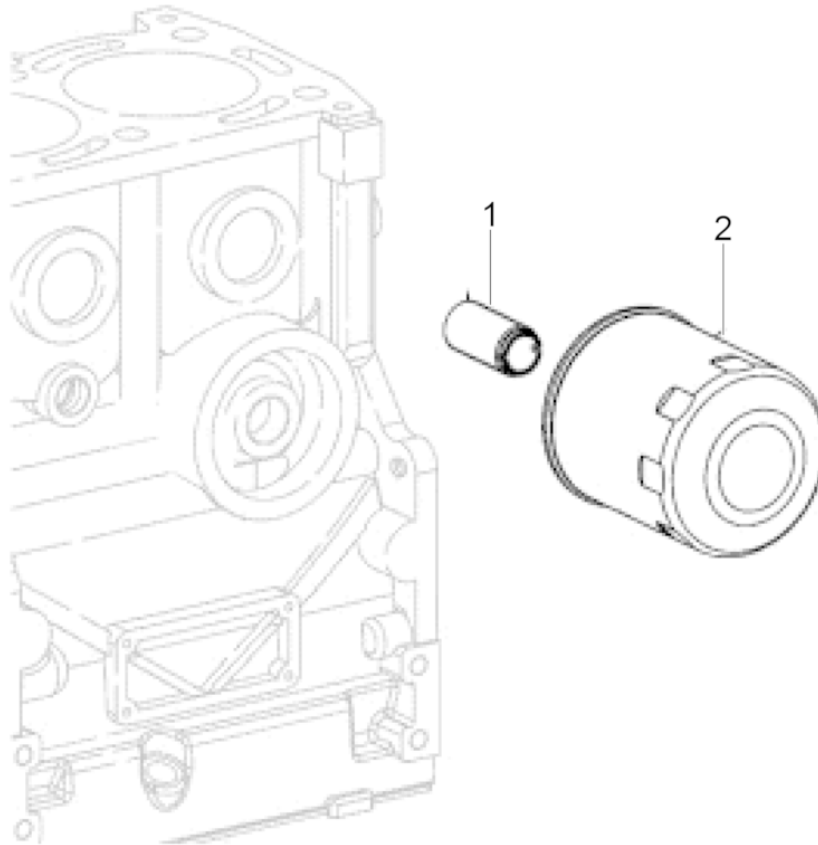

200\_5200015979001015

Ref. Pos.	Part No. Artikel Nr.	Qty. St.	Description Beschreibung	Descripción Description	Measurem./Abm.	Norm
					Torque/Drehm.	Sealant Schmierstoff
1	0159341	1	Fitting-oil filter Ölfilterverschraubung	Unión de filtro de aceite de aceite Raccord de filtre d'huile		
2	0155736	1	Oil filter Ölfiter	Filtro de aceite Filtre d'huile		

Oil Dipstick  
Ölpeilstab  
Indicador del nivel de aceite  
Réglette-jauge d'huile

RTLx-SC3

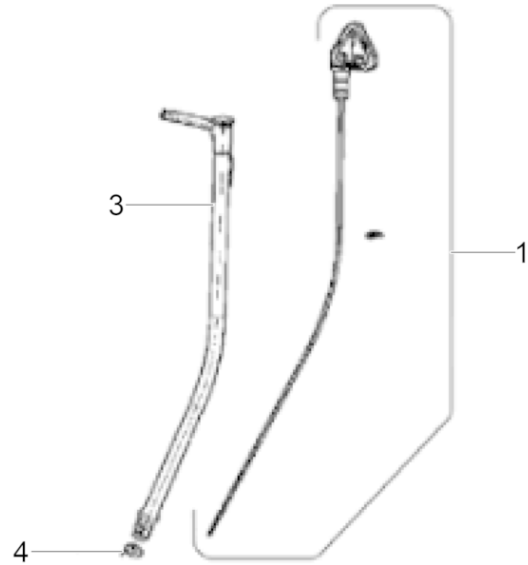
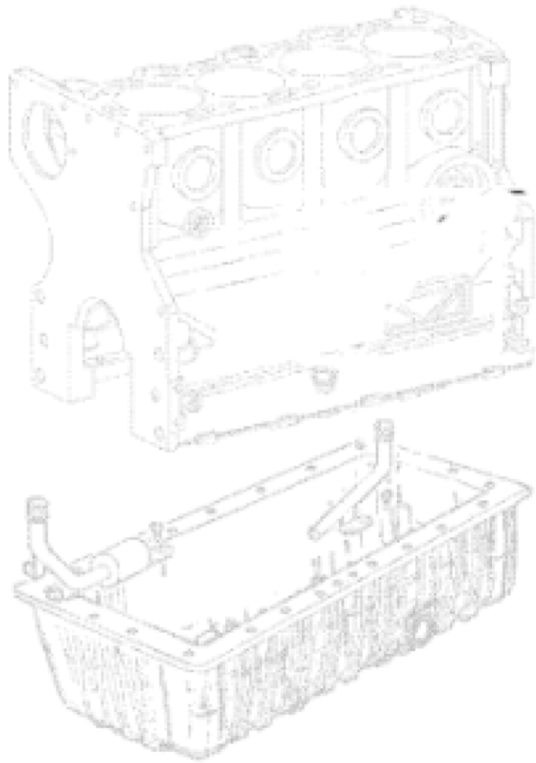

200\_5200015979001016

Ref. Pos.	Part No. Artikel Nr.	Qty. St.	Description Beschreibung	Descripción Description	Measurem./Abm.	Norm
					Torque/Drehm.	Sealant Schmierstoff
1	5200009507	1	Oil dipstick Ölpeilstab	Indicador del nivel de aceite Réglette-jauge d'huile		
3	0155739	1	Protection Schutz	Protecciónel de aceite Protection		
4	5200009508	2	O-Ring O-Ring	Anillo-O Joint torique		

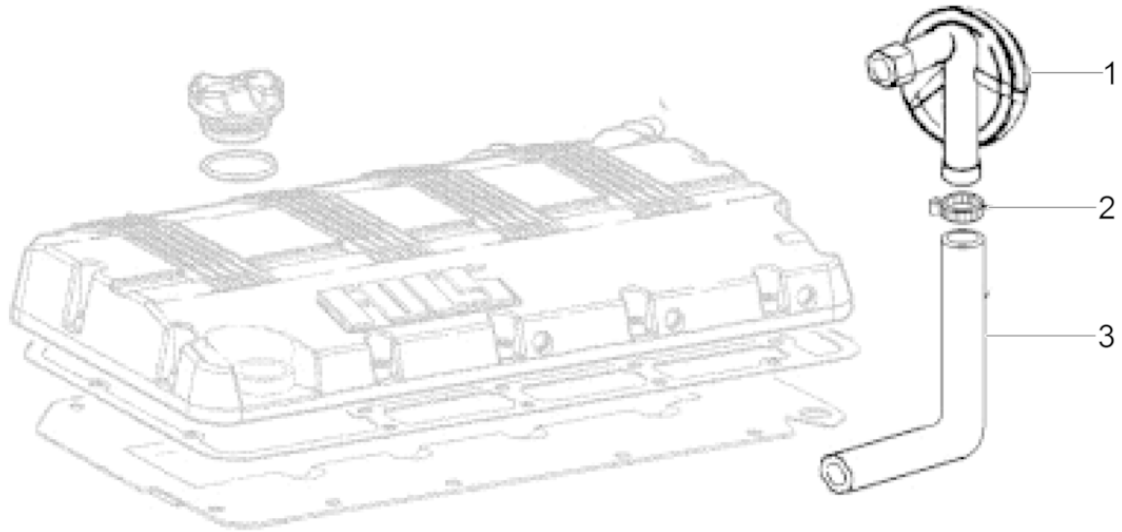

200\_5200015979001017

Ref. Pos.	Part No. Artikel Nr.	Qty. St.	Description Beschreibung	Descripción Description	Measurem./Abm.	Norm
					Torque/Drehm.	Sealant Schmierstoff
1	0155745	1	Pressure valve Überdruckventil	Válvula de sobrepresión Soupape de surpression		
2	0160201	2	Clamp Schelle	Abrazadera Attache		
3	0159460	1	Tube Rohr	Tubo Tube		

**Speed Governor**  
**Drehzahlregler**  
**Regulador de velocidad**  
**Régulateur de vitesse**

**RTLx-SC3**

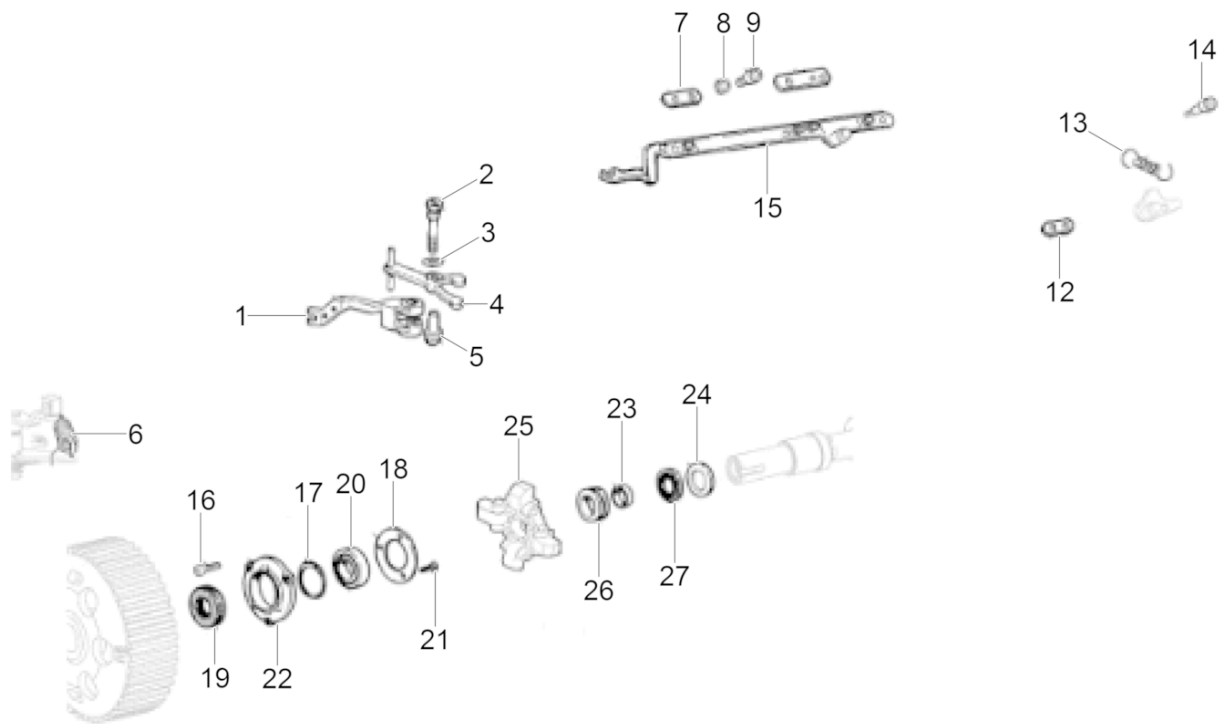

200\_5200015979001018



Ref. Pos.	Part No. Artikel Nr.	Qty. St.	Description Beschreibung	Descripción Description	Measurem./Abm.	Norm
					Torque/Drehm.	Sealant Schmierstoff
1	0159304	1	Governor lever cpl. Reglerhebel kpl.	Palanca de regulador cpl. Lever régulateur cpl.		
2	0159321	1	Pin Stift	Espiga Goupille		
3	0159229	1	Oil Seal Öldichtung	Junta de Aceite Joint D'Huile		
5	0215480	1	Collar Hülse	Collar Douille		
6	0159314	1	Spring-governor Reglerfeder	Resorte del regulador Ressort régulateur		
7	5200009512	1	Plate Platte	Placa Plaque		
8	0215520	2	Washer Scheibe	Disco Rondelle		
9	0159477	4	Screw Schraube	Tornillo Vis		
12	0160220	1	Plate Platte	Placa Plaque		
13	0159315	1	Spring Feder	Resorte Ressort		
14	0211941	3	Screw Schraube	Tornillo Vis		
15	0159245	1	Linkage Gestänge	Varillaje Tringles		
16	0159467	3	Cover Deckel	Cubierta Couvercle		
17	0159239	1	Collar Hülse	Collar Douille		
18	0159324	1	Check disc Anlaufscheibe	Arandela tope Disque		
19	0159240	1	Speed control module Drehzahlregler	Controlador de velocidad Régulateur de vitesse		
20	0159267	1	Collar Hülse	Collar Douille		
21	5200009514	3	Screw Schraube	Tornillo Vis		
22	0159265	1	Cover Deckel	Cubierta Couvercle		
23	0159251	1	Collar Hülse	Collar Douille		
24	0215517	1	Check disc Anlaufscheibe	Arandela tope Disque		
25	0155698	1	Speed control module Drehzahlregler	Controlador de velocidad Régulateur de vitesse		
26	0215506	1	Collar Hülse	Collar Douille		
27	5200009517	1	Bearing Lager	Rodamiento Roulement		

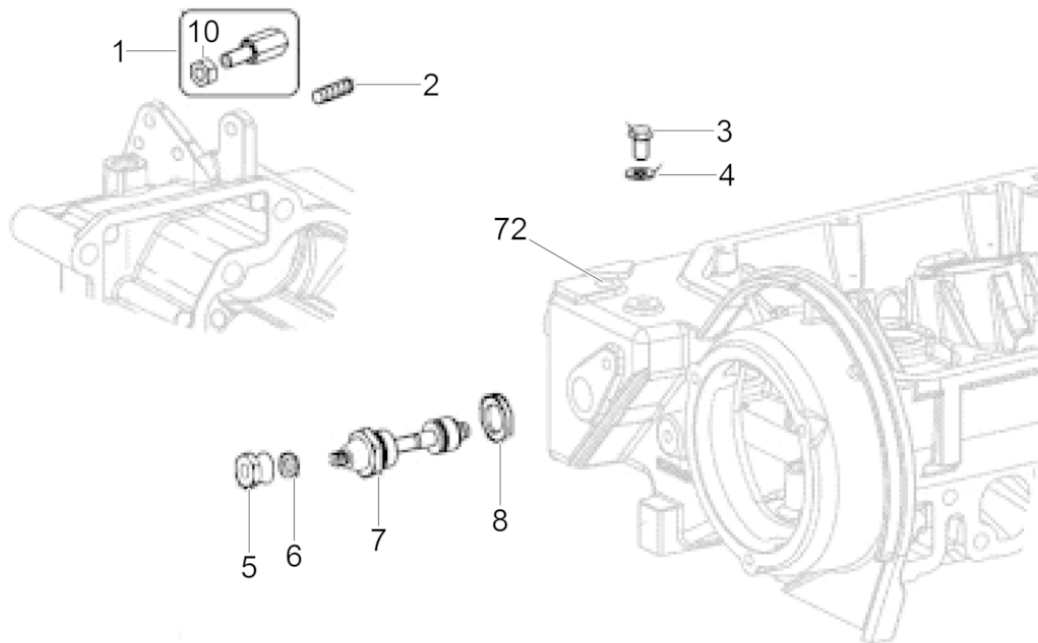

200\_5200015979001019

Ref. Pos.	Part No. Artikel Nr.	Qty. St.	Description Beschreibung	Descripción Description	Measurement./Abm.	Norm
					Torque/Drehm.	Sealant Schmierstoff
1	0159457	1	Screw Schraube	Tornillo Vis		
2	0215543	1	Screw Schraube	Tornillo Vis		
3	0084131	2	Screw Schraube	Tornillo Vis		
4	0083995	2	Washer Scheibe	Arandela Rondelle		
5	5200009518	2	Nut Mutter	Tuerca Écrou		
6	5200009519	1	Washer Scheibe	Arandela Rondelle		
7	0160389	1	Hose Schlauch	Manguera Tuyau		
8	0159272	1	Nut Mutter	Tuerca Écrou		
10	0159272	1	Nut Mutter	Tuerca Écrou		
72	0215528	1	Plug Stopfen	Tapón Bouchon		

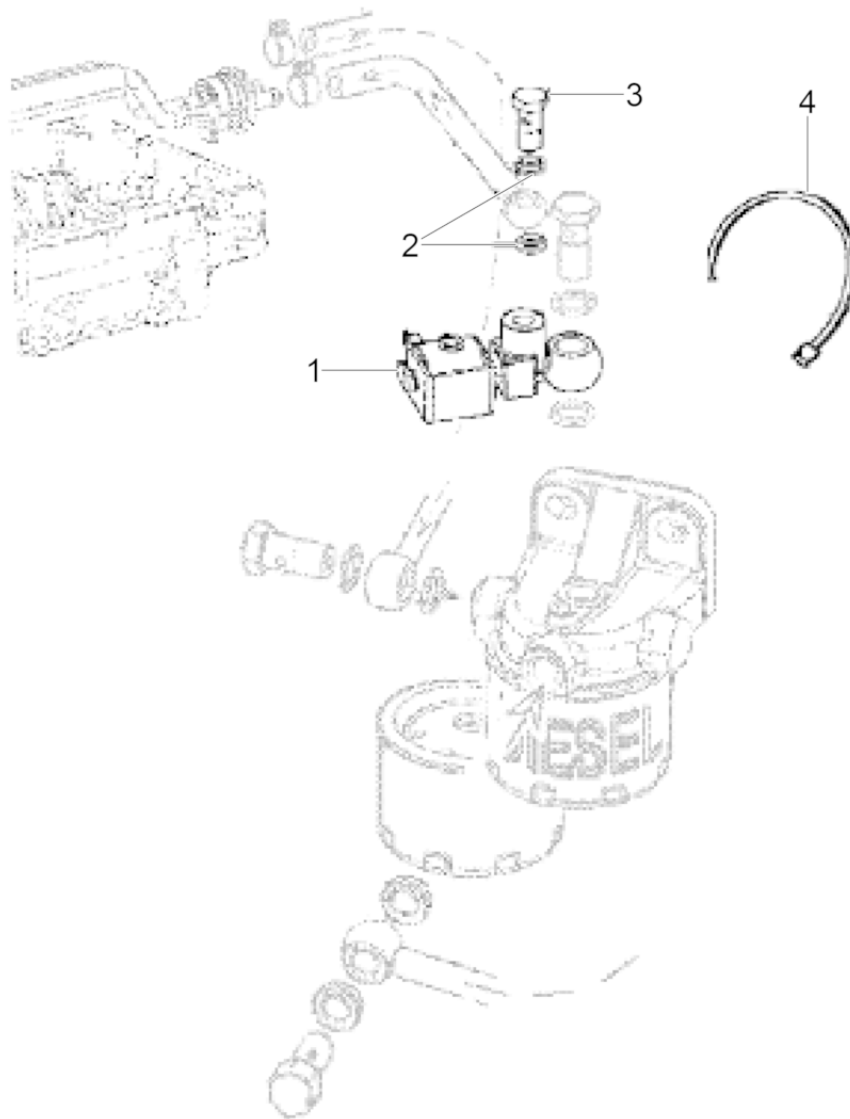

200\_5200015979001020

Ref. Pos.	Part No. Artikel Nr.	Qty. St.	Description Beschreibung	Descripción Description	Measurement./Abm.	Norm
					Torque/Drehm.	Sealant Schmierstoff
1	0155711	1	Fuel valve Kraftstoffventil	Grifo de combustible Robinet de carburant		
2	0082183	2	Ring seal Dichtring	Anillo sellador Rondelle à étancher		
3	0082105	1	Screw Schraube	Tornillo Vis		
4	0215486	1	Collar Manschette	Collar Collet		

Fuel Filter  
Kraftstofffilter  
Filtro de Combustible  
Filtre à Carburant

RTLx-SC3

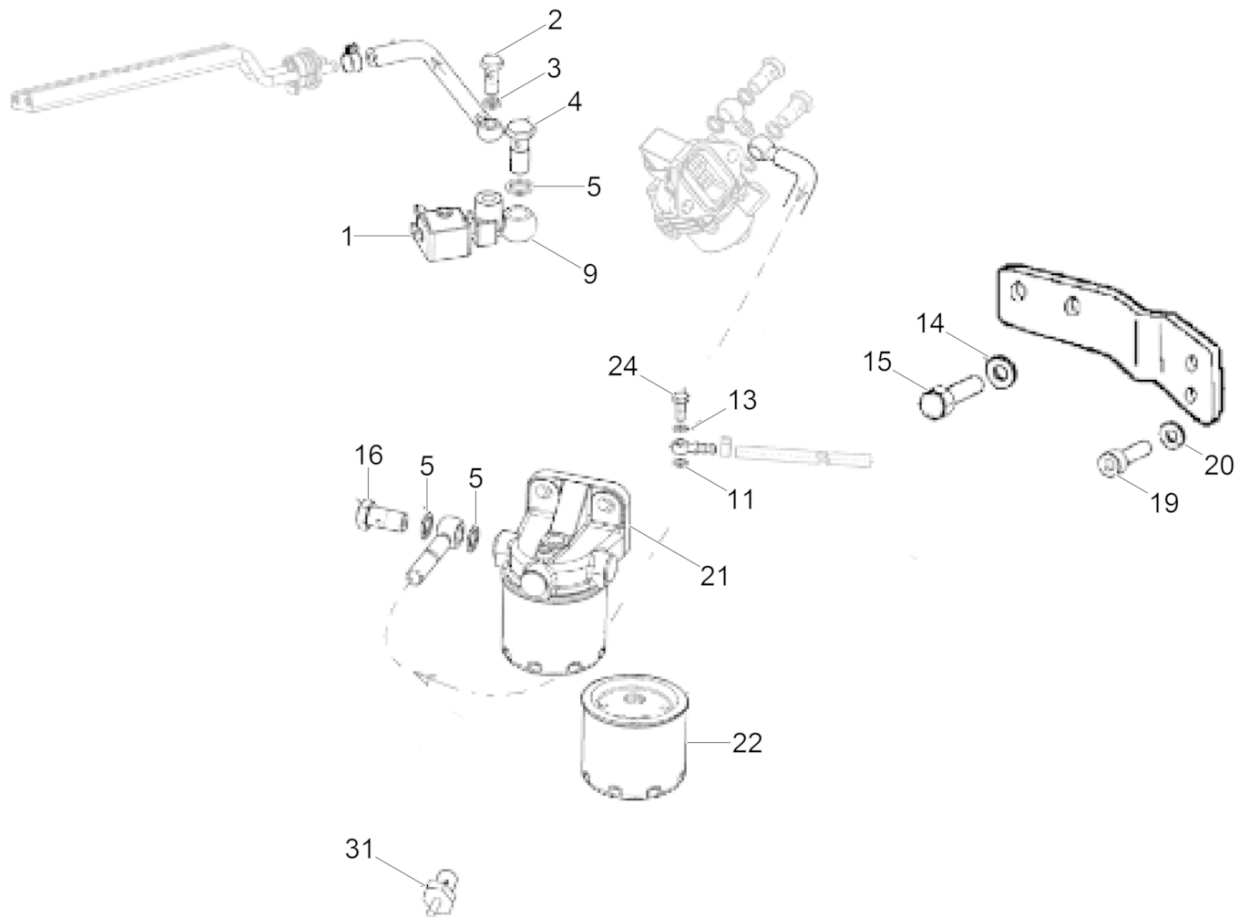

200\_5200015979001021

Ref. Pos.	Part No. Artikel Nr.	Qty. St.	Description Beschreibung	Descripción Description	Measurement./Abm.	Norm
					Torque/Drehm.	Sealant Schmierstoff
1	0155710	1	Jet Düse	Chicler Gicleur		
2	0082105	1	Screw Schraube	Tornillo Vis		
3	0082183	1	Ring seal Dichtring	Anillo sellador Rondelle à étancher		
4	0159250	1	Screw Schraube	Tornillo Vis		
5	0082185	6	Gasket Dichtung	Junta Joint		
9	0155711	1	Fuel valve Kraftstoffventil	Grifo de combustible Robinet de carburant		
11	0203362	1	Nipple Nippel	Boquilla roscada Raccord fileté		
13	0083995	2	Washer Scheibe	Arandela Rondelle		
14	0160231	2	Washer Scheibe	Disco Rondelle		
15	0082100	2	Screw Schraube	Tornillo Vis	M10 x 22	
16	0082107	1	Banjo bolt Hohlschraube	Perno hueco Boulon creux à filet femelle		
19	0160363	2	Screw Schraube	Tornillo Vis	M8 x 20	
20	0160235	2	Washer Scheibe	Arandela Rondelle		
21	0205200	1	Fuel filter cpl. Kraftstofffilter kpl.	Filtro de combustible compl. Filtre à carburant compl.		
22	5200023966	1	Element Filterpatrone	Elemento Cartouche		
24	0084231	1	Screw Schraube	Tornillo Vis		
25	0082183	2	Ring seal Dichtring	Anillo sellador Rondelle à étancher		
31	0205203	1	Hollow screw Hohlschraubetil	Tornillo huecoora Boulon creux à filet femelle		

Fuel Feed Pump  
Förderpumpe  
Bomba de Alimentación  
Pompe d'Alimentation

RTLx-SC3



200\_5200015979001022



Ref. Pos.	Part No. Artikel Nr.	Qty. St.	Description Beschreibung	Descripción Description	Measurement./Abm.	Norm
					Torque/Drehm.	Sealant Schmierstoff
1	0155706	1	Fuel Pump Kraftstoffpumpe	Bomba de Combustible Pompe à Essence		
2	0082266	2	Stud Stiftschraube	Perno prisionero Boulon		
3	0110759	1	Seal Dichtung	Junta Joint		
4	0160757	1	Rod Stange	Varillae Tige		
5	0063700	2	Flange nut Flanschmutter	Tuerca de reborde Ecroû de bride		
6	0082285	2	Washer Scheibe	Arandela Rondelle		
7	0082183	4	Ring seal Dichtring	Anillo sellador Rondelle à étancher		
8	0082105	2	Screw Schraube	Tornillo Vis		

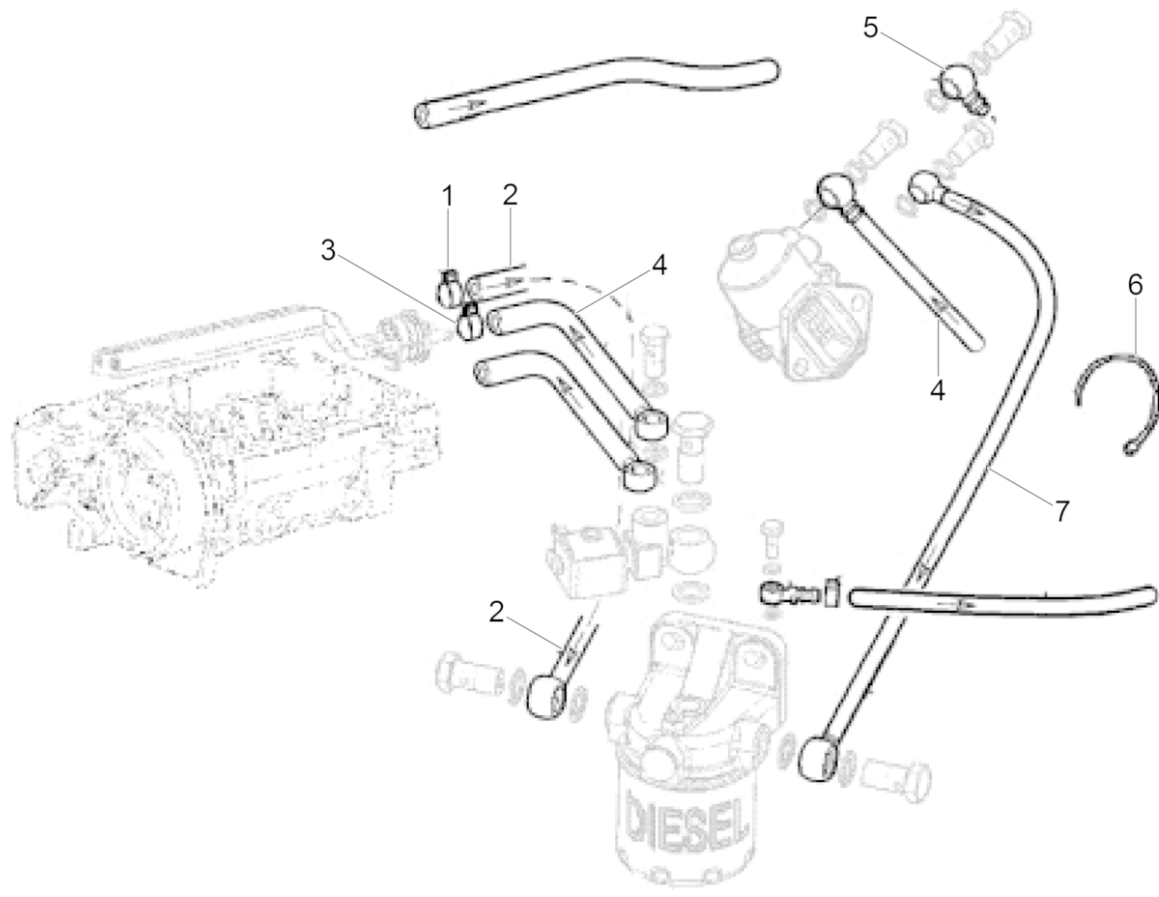

200\_5200015979001023

Ref. Pos.	Part No. Artikel Nr.	Qty. St.	Description Beschreibung	Descripción Description	Measurem./Abm.	Norm
					Torque/Drehm.	Sealant Schmierstoff
1	0082155	1	Clamp Schelle	Abrazadera Collier		
2	0205202	1	Fuel line Kraftstoffleitung	Manguera de combustible Conduit de carburant		
3	0215704	1	Clamp Schelle	Abrazadera Attache		
4	0210454	1	Fuel hose Kraftstoffleitung	Manguera de combustible Tuyau de carburant		
5	0159342	1	Hose fitting Schlauchverschraubung	Unión de manguera Raccord de tuyau		
6	0215486	3	Collar Manschette	Collar Collet		
7	0209978	1	Fuel hose Kraftstoffleitung	Manguera de combustible Tuyau de carburant	28.50in	

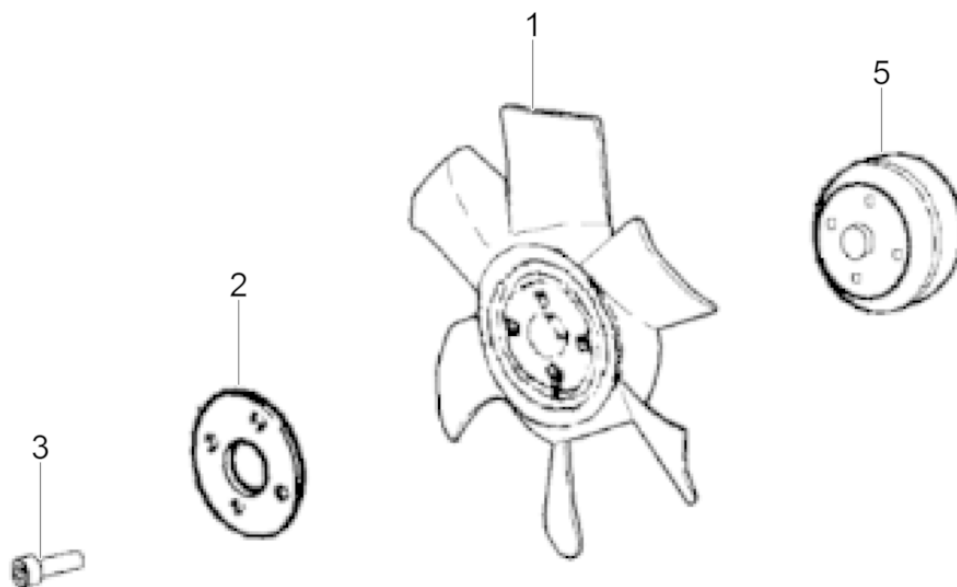

200\_5200015979001024

Ref. Pos.	Part No. Artikel Nr.	Qty. St.	Description Beschreibung	Descripción Description	Measurement./Abm.	Norm
					Torque/Drehm.	Sealant Schmierstoff
1	0159466	1	Fan Gebläserad	Ventilador Ventilateur		
2	0159323	1	Plate Platte	Placa Plaque		
3	0207992	4	Screw Schraube	Tornillo Vis		
5	0215498	1	Flange Flansch	Brida Bride	43,5mm	

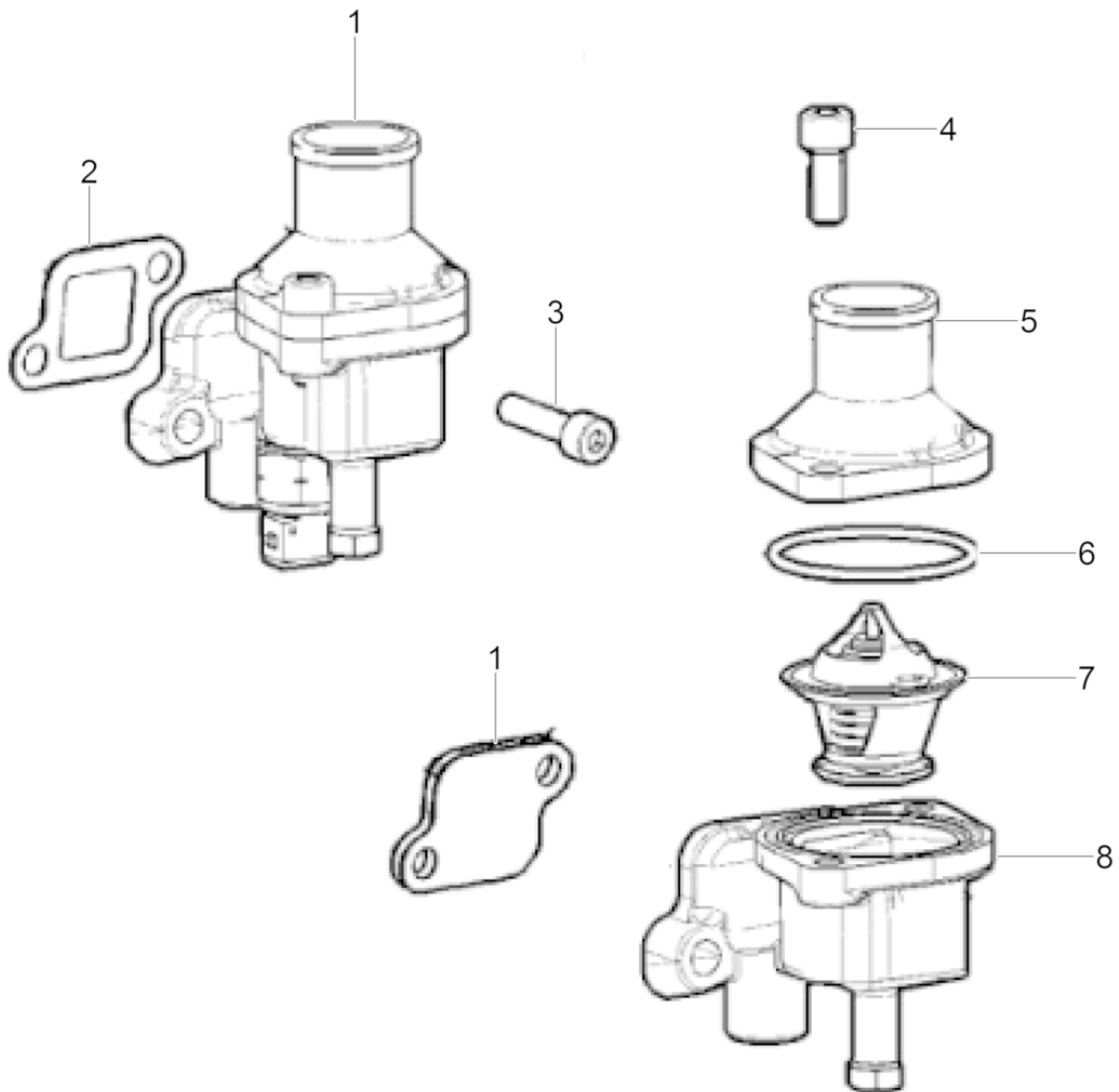

200\_5200015979001025

Ref. Pos.	Part No. Artikel Nr.	Qty. St.	Description Beschreibung	Descripción Description	Measurem./Abm.	Norm
					Torque/Drehm.	Sealant Schmierstoff
1	0160372	1	Housing Gehäuse	Caja Carter		
2	0207003	1	Gasket Dichtung	Junta Joint		
3	0159476	2	Screw Schraube	Tornillo Vis		
4	0084169	2	Screw Schraube	tornillo vis		
5	0159266	1	Thermostat cover Thermostatdeckel	Tapa del termóstato Couvercle du thermostat		
6	0159232	1	O-Ring O-Ring	Anillo-O Joint torique		
7	0207002	1	Valve-thermostat Thermostatventil	Válvula de gobierno termostático Soupape thermostatique		
8	0211375	1	Housing Gehäuse	Carcasa Enveloppe		
10	0160387	1	Sensor Sensoreinheit	Unidad de alertaa Appareil d'alerte		
12	0159299	1	Washer Scheibe	Disco Rondelle		



200\_5200015979001026



Ref. Pos.	Part No. Artikel Nr.	Qty. St.	Description Beschreibung	Descripción Description	Measurement/Abm.	Norm
					Torque/Drehm.	Sealant Schmierstoff
1	0160362	2	Screw Schraube	Tornillo Vis		
2	0159293	1	Gasket Dichtung	Junta Joint		
3	0155729	1	Hose/water flange Flansch-Schlauch/Wasser	Brida-manguera/agua Colerette-tuyau/eau		

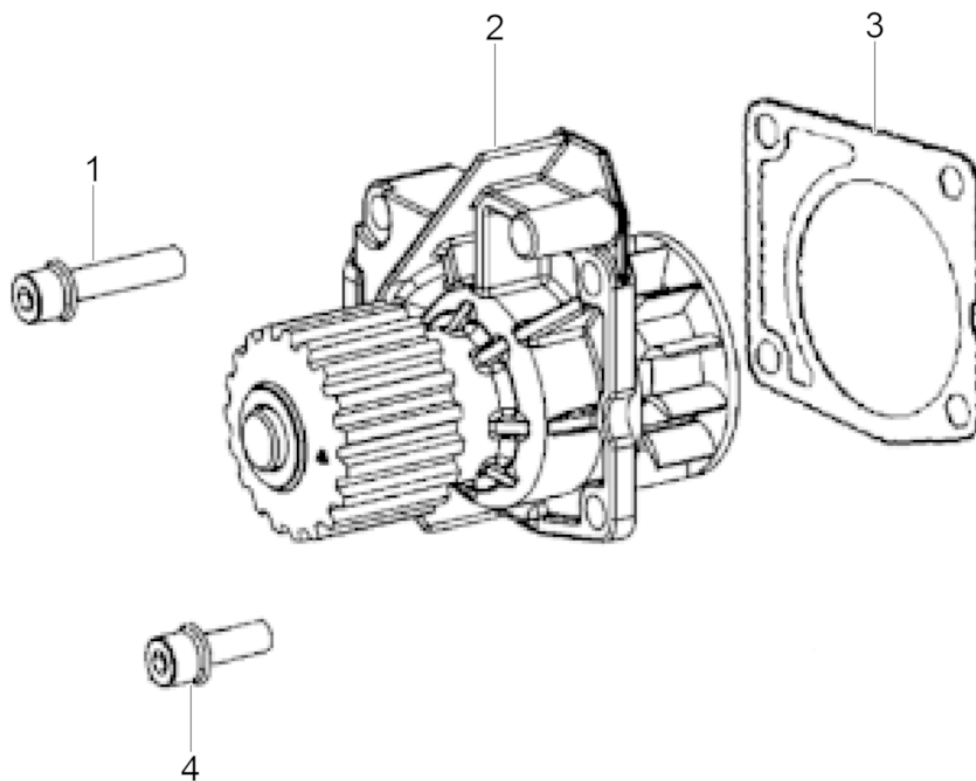

200\_5200015979001027

Ref. Pos.	Part No. Artikel Nr.	Qty. St.	Description Beschreibung	Descripción Description	Measurem./Abm.	Norm
					Torque/Drehm.	Sealant Schmierstoff
1	0209105	2	Hexagonal head cap screw Sechskantschraube	Tornillo hexagonal Vis à tête hexagonale		
2	0155719	1	Water pump cpl. Wasserpumpe kpl.	Bomba del agua compl. Pompe à eau compl.		
3	0159298	1	Gasket Dichtung	Junta Joint		
4	5200009523	2	Bolt Innensechskantschraube	Perno Boulon	M8	

**Air Inlet Manifold**  
**Einlassluftleitblech**  
**Conducto de aire de entrada**  
**Canal d'air d'admission**

**RTLx-SC3**

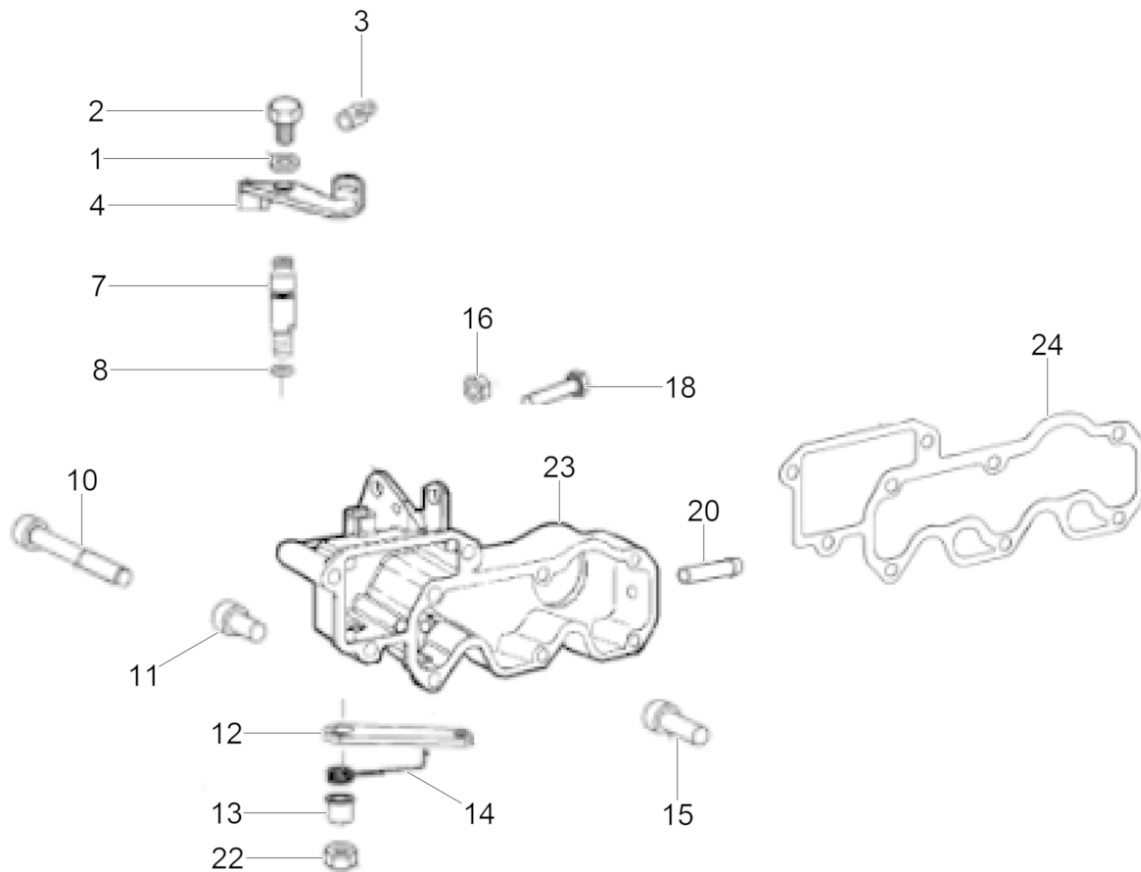

200\_5200015979001028

Ref. Pos.	Part No. Artikel Nr.	Qty. St.	Description Beschreibung	Descripción Description	Measurem./Abm.	Norm
					Torque/Drehm.	Sealant Schmierstoff
1	5200009524	1	Washer Scheibe	Arandela Rondelle		
2	5200009525	1	Bolt Bolzen	Perno Boulon	M8	
3	0203352	1	Clamping piece Klemmstück	Pieza de fijación Pièce de serrage		
4	0160214	1	Lever Hebel	Palanca Levier		
7	5200009526	1	Throttle pin Gasreglerwelle	Pasador de mariposa Goupille des gaz		
8	0159230	1	Oil Seal Öldichtung	Junta de Aceite Joint D'Huile		
10	0084170	1	Screw Schraube	Tornillo Vis		
11	0159476	3	Screw Schraube	Tornillo Vis		
12	0215504	1	Lever Hebel	Palanca Levier		
13	0215481	1	Collar Hülse	Collar Douille		
14	0215508	1	Spring Feder	Resorte Ressort		
15	0203346	4	Screw Schraube	tornillo vis		
16	0159272	2	Nut Mutter	Tuerca Écrou		
18	0206214	2	Screw Schraube	Tornillo Vis	M6 x 30	
20	0159462	1	Hose Schlauch	Manguera Boyau		
22	0084232	1	Nut Mutter	Tuerca Ecrou		
23	0215487	1	Manifold inlet Verteiler, Einlass	Distribuidor, admisión Tubulure, admission		
24	0160186	1	Intake manifold gasket Ansaugkrümmerdichtung	Junta-distribuidor de admisión Joint-collecteur d'admission		
39	0084171	1	Screw Schraube	Tornillo Vis		

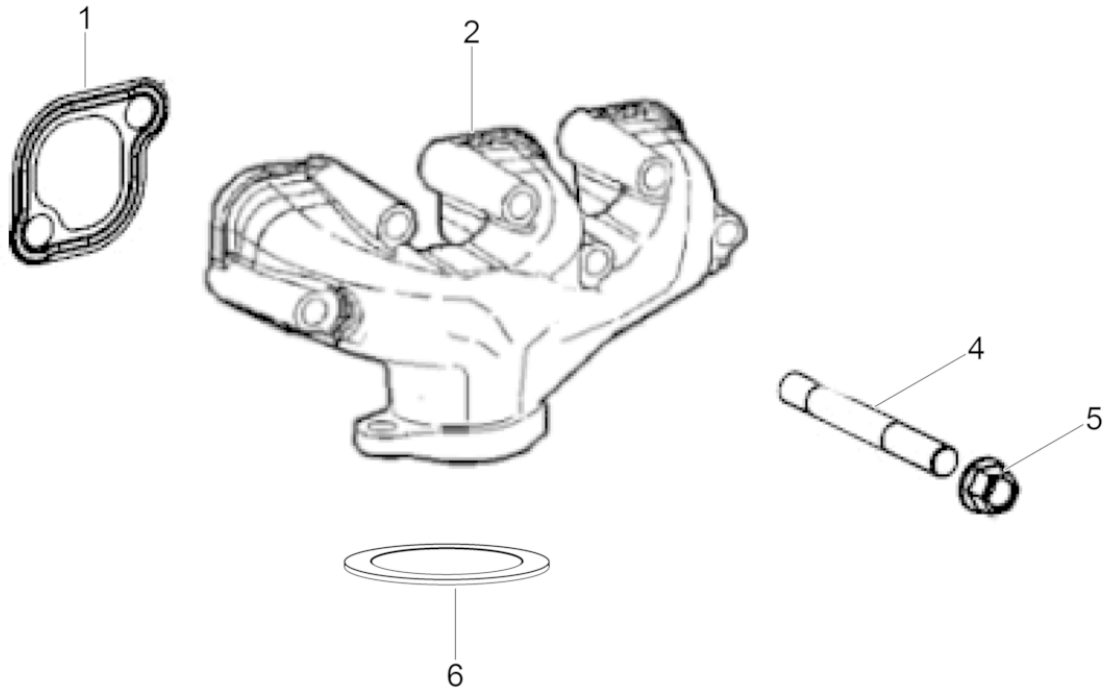

200\_5200015979001029

Ref. Pos.	Part No. Artikel Nr.	Qty. St.	Description Beschreibung	Descripción Description	Measurement./Abm.	Norm
					Torque/Drehm.	Sealant Schmierstoff
1	0159290	3	Gasket Dichtung	Junta de estanqueidad Garniture		
2	0159263	1	Exhaust manifold Auspuffkrümmer	Distribuidor de escape Collecteur d'échappement		
4	0082267	6	Stud Gewindebolzen	Perno prisionero Boulon		
5	0086331	6	Nut Mutter	Tuerca Écrou		
6	0159295	1	Gasket Dichtung	Junta de estanqueidad Garniture		

**Voltage Regulator  
Spannungsregler  
Regulador de voltaje  
Régulateur de tension**

**RTLx-SC3**

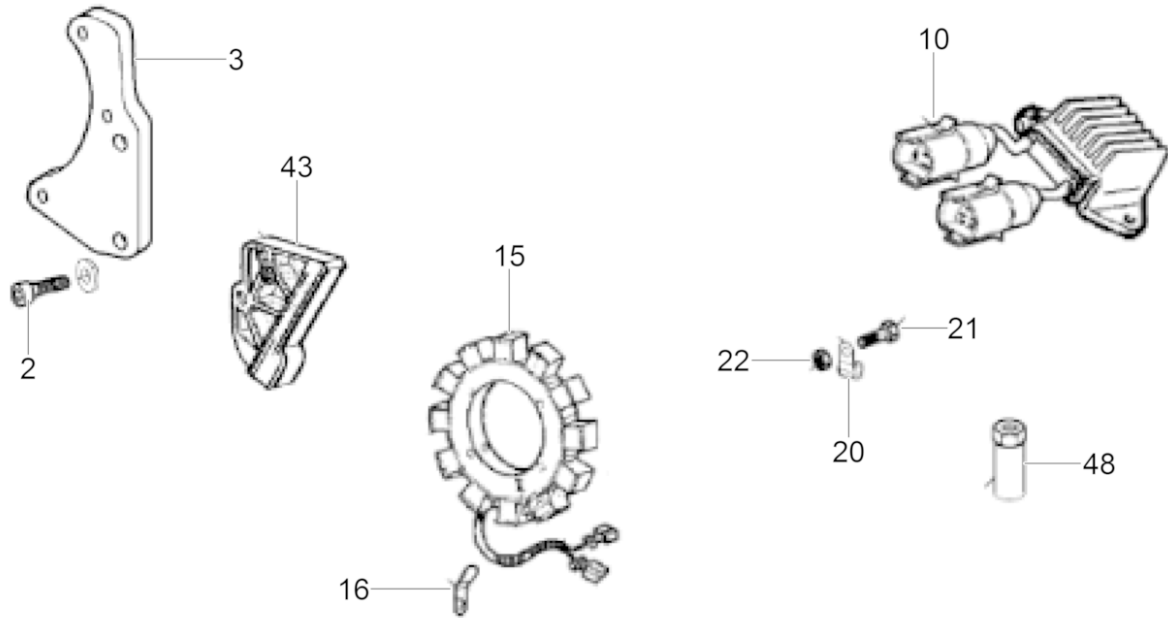

200\_5200015979001030



Ref. Pos.	Part No. Artikel Nr.	Qty. St.	Description Beschreibung	Descripción Description	Measurement./Abm.	Norm
					Torque/Drehm.	Sealant Schmierstoff
2	0159476	2	Screw Schraube	Tornillo Vis		
3	5200023967	1	Alternator support Konsole für Lichtmaschine	Soporte para alternador Support pour alternateur		
10	5200000154	1	Voltage regulator Spannungsregler	Regulador de voltaje Régulateur de tension		
15	0159446	1	Stator Stator	Estator Stator		
16	5200023968	1	Plate Platte	Placa Plaque		
20	0209002	1	Clamp Schelle	Abrazadera Collier		
21	0084156	1	Screw Schraube	Tornillo Vis		
22	0082140	1	Nut Mutter	Tuerca Écrou		
43	0159283	1	Flange Flansch	Brida Bride		
48	5200000140	2	Nut Mutter	Tuerca Écrou	M8 25Nm/18ft.lbs	



200\_5200015979001031

Ref. Pos.	Part No. Artikel Nr.	Qty. St.	Description Beschreibung	Descripción Description	Measurement./Abm.	Norm
					Torque/Drehm.	Sealant Schmierstoff
1	0215493	1	Hexagon nut Sechskantmutter	Tuerca hexagonal Écrou hexagonal		
2	0082288	1	Washer Scheibe	Arandela Rondelle		
3	0160374	1	Starter Motor Anlasser	Motor de Arranque Démarreur		
4	0206968	1	Flange Flansch	Brida Bride		
9	0083027	2	Screw Schraube	Tornillo Vis		

Glow Plug  
Glühkerze

RTLx-SC3

Tapón luminoso  
Bougie de préchauffage

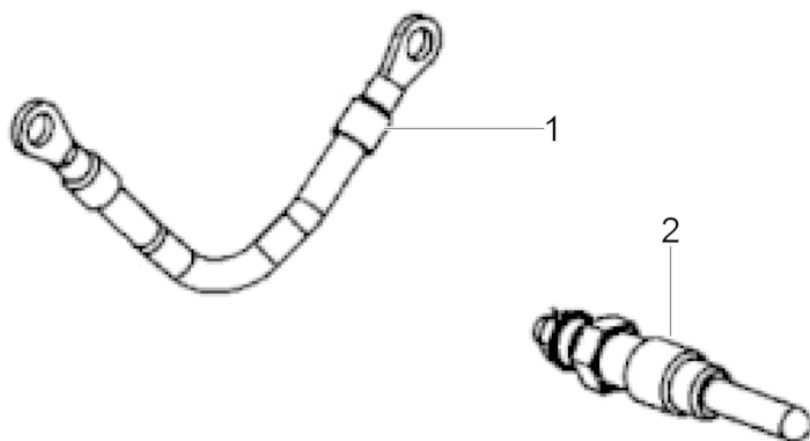

200\_5200015979001032

Ref. Pos.	Part No. Artikel Nr.	Qty. St.	Description Beschreibung	Descripción Description	Measurement./Abm.	Norm
					Torque/Drehm.	Sealant Schmierstoff
1	0159259	2	Cable Kabel	Cable Câble		
2	0155748	3	Glow plug Glühkerze	Tapón luminoso Bougie de préchauffage		

**Hydraulic Pump Adapter  
Adapter für Hydraulikpumpe  
Adaptador para bomba hidráulica  
Raccord pour pompe hydraulique**

**RTLx-SC3**



200\_5200015979001033

Ref. Pos.	Part No. Artikel Nr.	Qty. St.	Description Beschreibung	Descripción Description	Measurement./Abm.	Norm
					Torque/Drehm.	Sealant Schmierstoff
1	0161077	1	Coupling Kupplung	Acoplamiento Accouplement		
2	0084164	3	Screw Schraube	Tornillo Vis		
3	0161076	1	Housing Gehäuse	Caja Carter		
4	0161078	1	Spacer Abstandsstück	Espaciador Entretoise		
5	0161080	2	Dowel pin Paßstift	Espiga Cheville		
6	0082140	5	Nut Mutter	Tuerca Écrou		
7	0084123	7	Screw Schraube	Tornillo Vis		

**Hydraulic Pump Adapter 2**  
**Adapter für Hydraulikpumpe 2**  
**Adaptador para bomba hidráulica 2**  
**Raccord pour pompe hydraulique**

**RTLx-SC3**

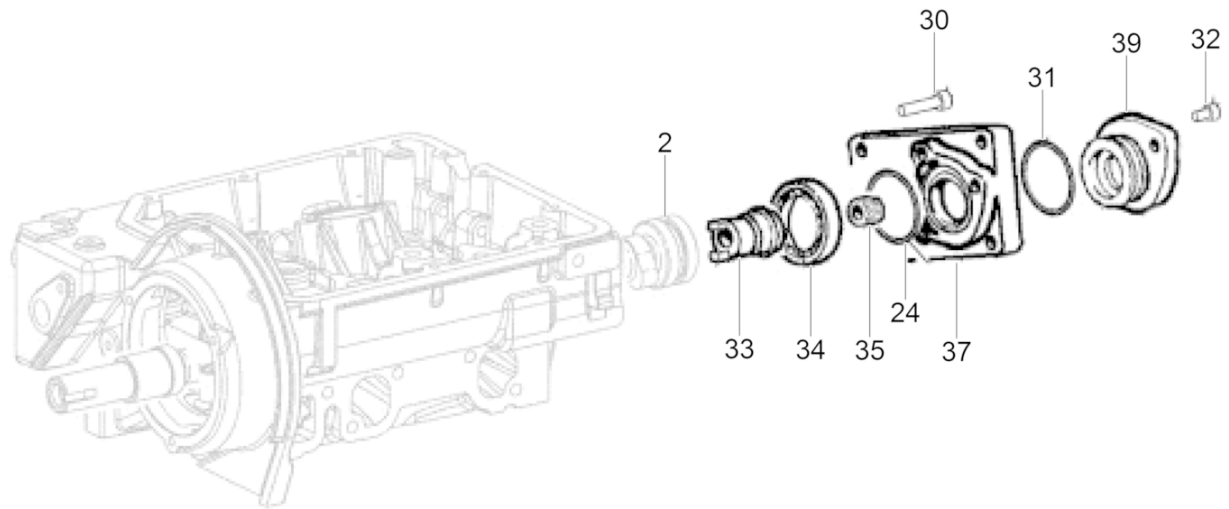

200\_5200015979001034



Ref. Pos.	Part No. Artikel Nr.	Qty. St.	Description Beschreibung	Descripción Description	Measurement./Abm.	Norm
					Torque/Drehm.	Sealant Schmierstoff
2	0160761	1	O-Ring O-Ring	Anillo-O Joint torique	1,42in	
24	0159234	1	Oil Seal Öldichtung	Junta de Aceite Joint D'Huile		
30	0160763	3	Bolt Bolzen	Perno Boulon		
31	0110759	1	Seal Dichtung	Junta Joint		
32	0160764	2	Bolt Bolzen	Perno Boulon		
33	0160754	1	Bushing Buchse	Buje Douille		
34	0160759	1	Ball bearing Kugellager	Rodamiento de bolas Roulement à billes		
35	0160755	1	Spline coupling Keilnutenkupplung	Acoplamiento de chaveta y ranura Accouplement cannelé		
37	0160758	1	Flange Flansch	Brida Collerette		
39	0160756	1	Cover Deckel	Tapa Couvercle		

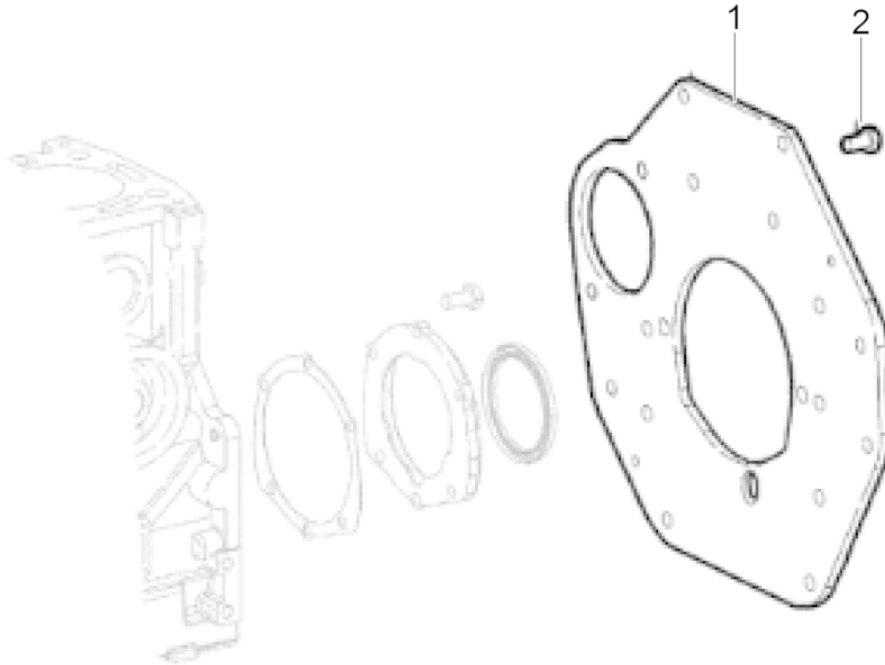

200\_5200015979001035

Ref. Pos.	Part No. Artikel Nr.	Qty. St.	Description Beschreibung	Descripción Description	Measuram./Abm.	Norm
					Torque/Drehm.	Sealant Schmierstoff
1	0159326	1	Plate Platte	Placa Plaque		
2	0159254	9	Bolt Bolzen	Perno Boulon		
4	5200009534	1	Plug Stopfen	Tapón Bouchon		

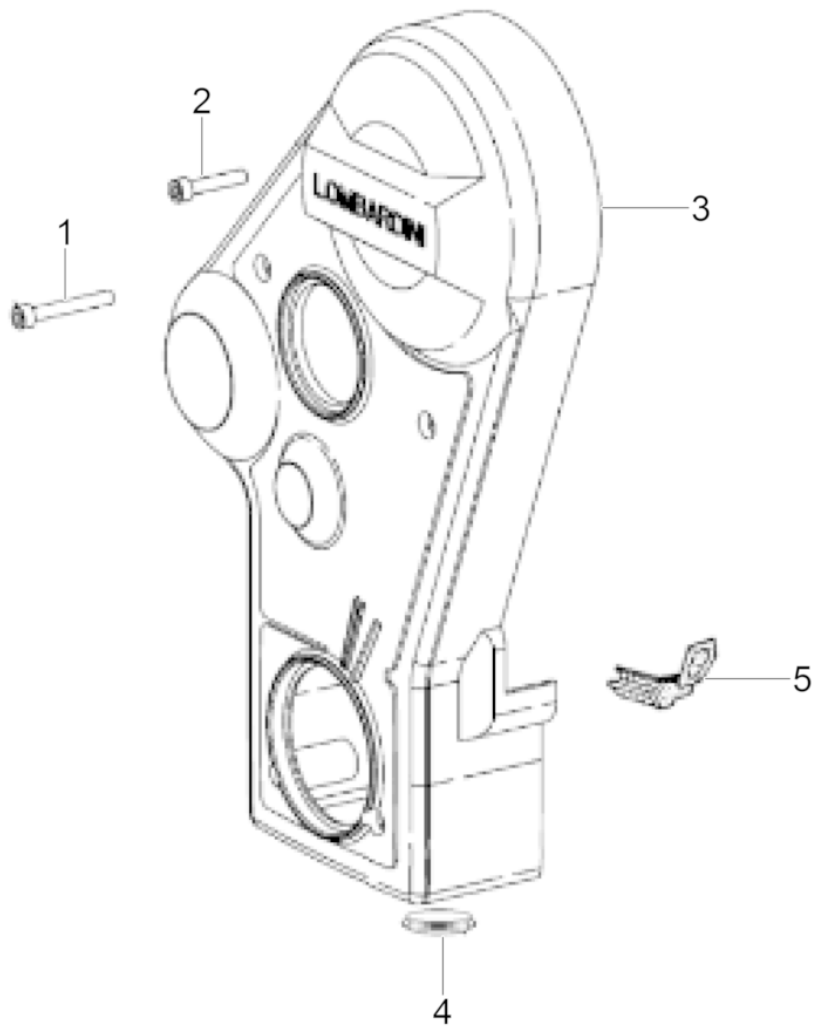

200\_5200015979001036

Ref. Pos.	Part No. Artikel Nr.	Qty. St.	Description Beschreibung	Descripción Description	Measurement./Abm.	Norm
					Torque/Drehm.	Sealant Schmierstoff
1	0159564	1	Screw Schraube	Tornillo Vis		
2	0159475	4	Screw Schraube	tornillo vis		
3	0159335	1	Beltguard Riemenschutz	Guardacorrea Protection de courroie		
4	0159268	1	Plug Stopfen	Enchufe Prise		
5	0215499	1	Gasket Dichtung	Junta de estanqueidad Garniture		





**WACKER  
NEUSON**

**Accessories  
Sonderzubehör  
Accesorios  
Accessoires**

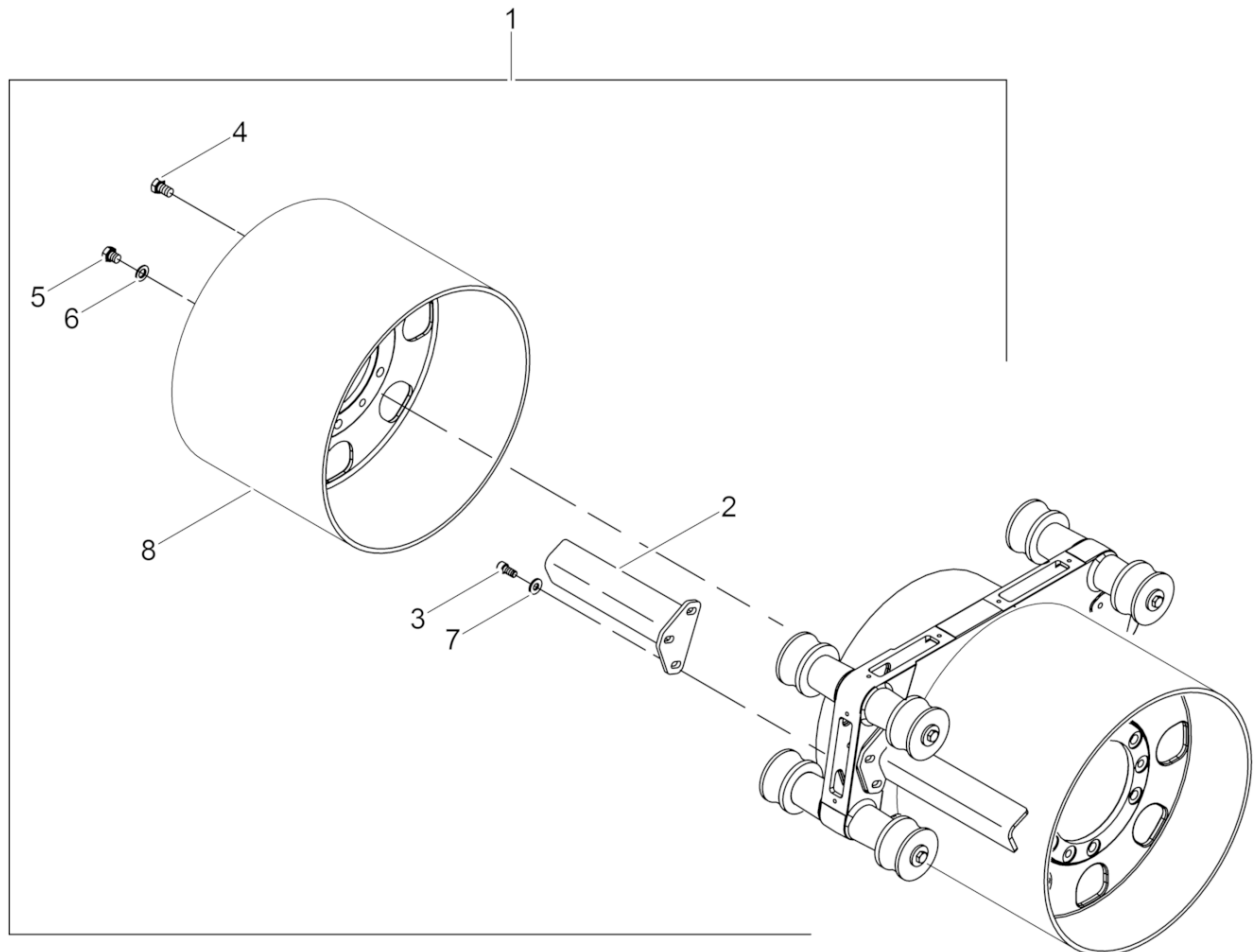

wc\_ex0162787001



Ref. Pos.	Part No. Artikel Nr.	Qty. St.	Description Beschreibung	Descripción Description	Measurement./Abm.	Norm
					Torque/Drehm.	Sealant Schmierstoff
1	0162787	1	Smooth drum kit Bandagensatz	Juego de tambor (plano) Jeu de tambour (lisse)	1000mm/40in	
2	5200006892	8	Wide scraper Bandage-Abstreifer	Barra raspadora-ancho Racleur large		
3	0017087	24	Socket head cap screw Zylinderschraube	Tornillo cilíndrico Vis à tête cylindrique	M12 x 30 86Nm/63ft.lbs	ISO4762 S3
4	0011542	24	Cheese head screw Zylinderschraube	Tornillo cilíndrico Vis à tête cylindrique	202Nm/149ft.lbs	S3
5	0031826	12	Screw Schraube	Tornillo Vis	M16 x 16 202Nm/149ft.lbs	S3
6	0010618	24	Flat washer Scheibe	Arandela Rondelle	16	ISO7090
7	0031565	24	Lockwasher Spannscheibe	Arandela elástica Rondelle de ressort	12	DIN6796
8	0171665	4	Smooth drum Bandage (glatt)	Tambor (plano) Tambour (lisse)	820	



**WACKER  
NEUSON**