



**WACKER
NEUSON**

5100039613	103
02.2018	

**Trench Rollers
Grabenwalzen
Rodillos para Zanjas
Rouleaux à pieds d'ameurs**

RTKx-SC3

**Parts Book
Ersatzteile
Lista de Repuestos
Liste de Pièces de Rechange**

www.wackerneuson.com

A nameplate listing the Model Number, Item Number, Revision, and Serial Number is attached to each unit. Please record the information found on this plate so it will be available should the nameplate become lost or damaged. When ordering parts or requesting service information, you will always be asked to specify the model, item number, revision number, and serial number of the unit.

Ein Typenschild mit Typ, Artikelnummer, Version und Maschinen-Nummer ist an jedem Gerät angebracht. Die Daten von diesem Schild bitte notieren, damit sie auch bei Verlust oder Beschädigung des Schildes noch vorhanden sind. Der Typ, die Artikel-Nummer, die Versions- Nummer und die Maschinen-Nummer sind bei der Ersatzteilbestellung oder Nachfragen bezüglich Service-Informationen stets erforderlich.

Una placa de identificación con el modelo, número de referencia, nivel de revisión y número de serie ha sido añadida en cada máquina. Favor de anotar los datos en la placa en caso de que la placa de identificación sea destruida o perdida. En todos los pedidos para repuestos necesita siempre el modelo, el número de referencia, el nivel de revisión y el número de serie de la máquina en cuestión.

Une plaque signalétique mentionnant le modèle, le numéro de référence, le niveau de révision et le numéro de série est fixée sur chaque machine. Veuillez noter les informations relevées sur cette plaque de façon à ce qu'elles soient toujours disponibles si la plaque signalétique venait à être perdue ou endommagée. Lorsque vous commandez des pièces détachées ou vous sollicitez des informations après-vente, on vous demandera toujours de préciser le modèle, le numéro de référence, le niveau de révision et le numéro de série de la machine.

***My machine's numbers are / Die Nummern meines Gerätes sind /
Los números de mi máquina son / Les numéros de ma machine son :***



Part Numbers appearing in boldface type are recommended spare parts. This means that these parts are subject to wear under normal operating conditions and may require periodic service or replacement. It is recommended that these items be stocked to meet the expected service requirements of this model. Actual stocking quantities of these and other parts used in more extensive repairs will depend on the service practices of each customer.

Bei den in den Ersatzteillisten fettgedruckten Nummern handelt es sich um empfohlene Ersatzteile. Dies bedeutet, daß diese Teile bei normalen Anwendungsbedingungen natürlicher Abnutzung ausgesetzt sind und gelegentlich ersetzt oder überarbeitet werden müssen. Es wird geraten, diese Teile auf Lager bereit zu haben, um für Service-Arbeiten an diesem Gerät vorbereitet zu sein. Lagerbestände für diese und andere Teile, welche für ausgiebigere Reparaturarbeiten benötigt werden, können je nach Service-Gewohnheiten der einzelnen Kunden variieren.

Los números de partes en negritas en las Listas Ilustradas de Partes son los repuestos recomendados, ésto quiere decir que estas partes se desgastarán bajo circunstancias de funcionamiento normales y pueden requerir servicio periódico o su reemplazo. Se recomienda que el cliente mantenga un abastecimiento adecuado de estas partes para poder satisfacer la demanda requerida por el servicio a la máquina. La cantidad de repuestos que el cliente necesitará para reparaciones dependerá de la póliza de servicio de cada cliente.

Les numéros de pièces imprimés en caractères gras dans les Listes des Pièces Détachées de ce manuel sont les pièces détachées recommandées par la Wacker. Cela veut dire que ces pièces sont sujettes à usure dans des conditions de travail normales et peuvent nécessiter de l'entretien ou leur remplacement. Nous recommandons que vous disposez d'un stock de ces pièces pour pouvoir satisfaire la demande d'entretien de cette machine. Le client doit décider lui-même de la quantité exacte de pièces de rechange qu'il disposera dans ses stocks.

Engine Compartment Motorkasten Caja de Motor Boîte de Moteur	8
Front Frame Vorderrahmen Bastidor Delantero Châssis Avant	14
Articulated Steering Joint Knickgelenk Unión Articulada de Dirección Joint articulé	20
Electric Equipment/Wiring Armaturen/Leitungen Equipo Eléctrico/Cables Équipement Électrique/Câblage	22
Hydraulic Piping Hydraulik-Rohrleitung Tubería Hidráulica Canalisation Hydraulique	26
Hydraulic Piping Hydraulik-Rohrleitung Tubería Hidráulica Canalisation Hydraulique	28
Rear Frame Hinterrahmen Bastidor de Atrás Châssis Arrière	32
Front Cover Vorderdeckel Tapa delantera Couvercle avant	36
Rear Section/Controls Steuerkontrolle Sección Posterior/Palanca de Mando Partie Arrière/Guidons	38
Rear Cover Hinterdeckel Tapa de atrás Couvercle arrière	42
Drum Drive Bandagenantrieb Accionamiento de Tambor Entraînement de Tambour	44
Drum Drive w/Brake Bandagenantrieb mit Bremse Accionamiento de Tambor con Freno Entraînement de Tambour avec F	48
Front Drum Vorderbandage Tambor Delantero Tambour Avant	54
Rear Drum Hinterbandage Tambor de Atrás Tambour Arrière	56

Indice

Table des matières

Exciter cpl. Erreger kpl. Excitador compl. Excitatrice compl.	58
Hydraulic Manifold Hydraulikverteiler Distribuidor Hidráulico Tubulure Hydraulique	60
Hydraulic Tank Hydrauliktank Tanque Hidráulico Réservoir Hydraulique	64
Transmitter Module Sender Transmisor Transmetteur	66
Engine Service Parts Motor-Ersatzteile Repuestos de Motor Pièces Détachées du Moteur	68
Labels Aufkleber Calcomanias Autocollants	70
Accessories Sonderzubehör Accesorios Accessoires	73
Smooth Drum Kit Bandagensatz (glatt) Juego de tambor (plano) Jeu de tambour (lisse)	74

Engine Compartment
Motorkasten
Caja de Motor
Boîte de Moteur

RTKx-SC3

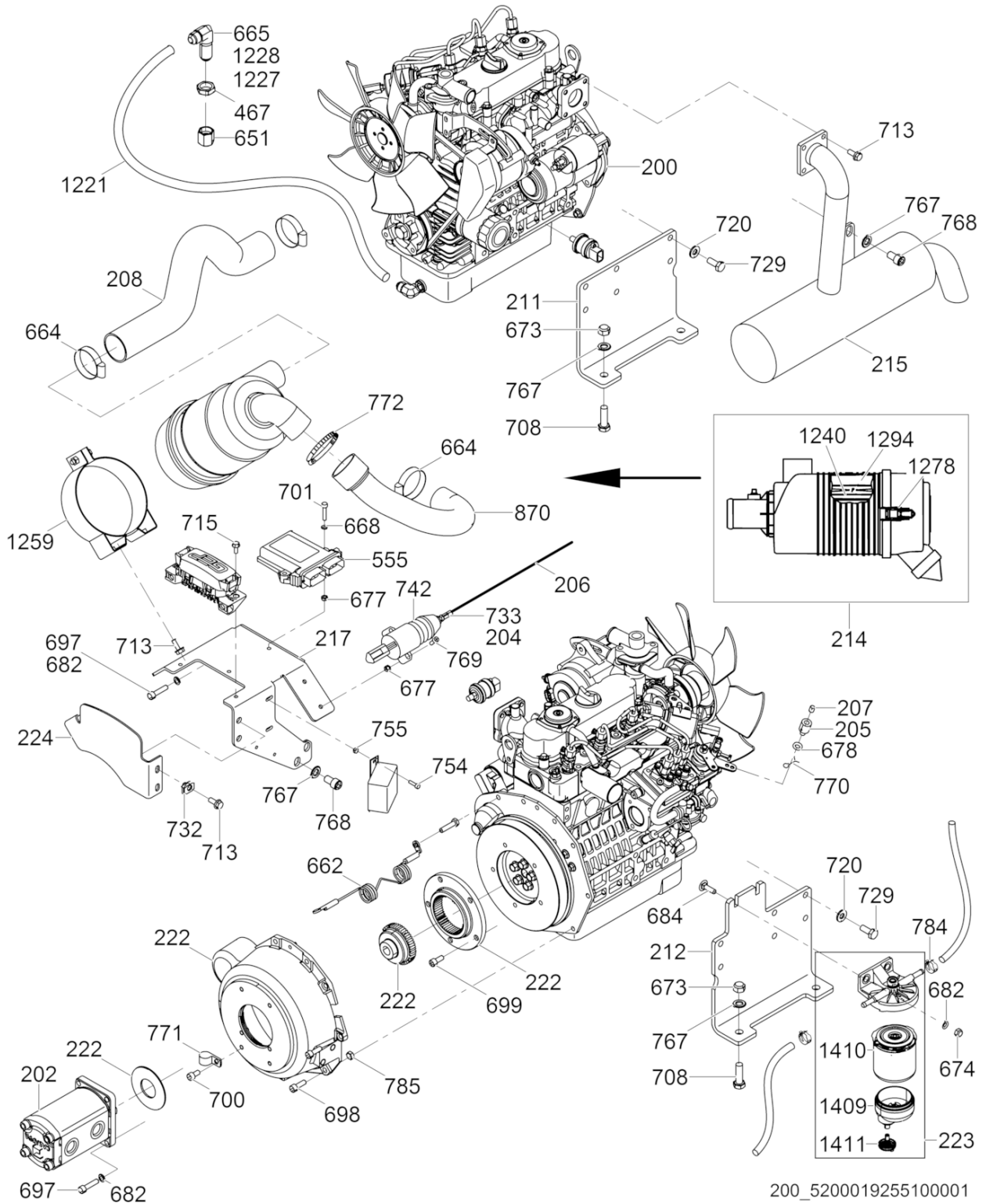

Ref. Pos.	Part No. Artikel Nr.	Qty. St.	Description Beschreibung	Descripción Description	Measurement./Abm.	Norm
					Torque/Drehm.	Sealant Schmierstoff
200	5200017279	1	Engine-Kubota Kubota-Motor	Motor Kubota Moteur Kubota		
202	5200015686	1	Exciter/Drive pump Erreger/Antriebs Pumpe	Bomba del excitador/accionamiento Pompe de l'excitatrice/d'entra		
204	5000155487	1	Adaptor Adapter	Adaptador Adaptateur		
205	5200017277	1	Sleeve Hülse	Manguito Douille		
206	5200017278	1	Throttle cable Bowdenzug	Cable del acelerador Câble des gaz		
207	5000156315	1	Setscrew Gewindestift	Tornillo Vis	M6 x 10	
208	5200015684	1	Air hose Druckluftschlauch	Manguera de aire Tuyau à air		
211	5200016458	1	Engine bracket Zylinderkonsole	Soporte del motor Support de culasse		
212	5200016459	1	Engine bracket Zylinderkonsole	Soporte del motor Support de culasse		
214	5000176114	1	Air cleaner Luftfilter	Filtro del aire Boîtier de filtre complet		
215	5200015413	1	Muffler Auspufftopf	Silenciador Pot d'échappement		
217	5200017659	1	Bracket Konsole	Soporte Support		
222	5200015702	1	Coupling cpl. Kupplung kpl.	Acoplamiento compl. Accouplement compl.		
223	5200018397	1	Fuel filter w/water separator Kraftstofffilter mit Wasserabscheider	Filtro de combustible con dispositivo para separar Filtre de carburant avec purge		
224	5200019619	1	Cover Deckel	Tapa Couvercle		
467	5000160579	1	Nut Mutter	Tuerca Écrou	No.8 x 3/4-16	
555	5200017913	1	Engine control module Motorkontrollmodul	Módulo de mando del motor Module de contrôle de moteur		
555	5200025081	1	Engine control module Motorkontrollmodul	Módulo de mando del motor Module de contrôle de moteur		
651	5000119929	1	Fitting cap Verschraubung, Kappe	Unión, tapa Raccord, Capuchon	No.8	
662	5200017605	1	Lanyard Trageschlaufe	Cordón Cordon		
664	5000119938	3	Hose clamp Schlauchschelle	Abrazaderas de manguera Agrafe de tuyau	No.32	
665	5000119960	1	Fitting Verschraubung	Unión Raccord	No.8	
673	5000010366	4	Hexagon nut Sechskantmutter	Tuerca hexagonal Écrou hexagonal	M12X1.75	DIN985
674	5000010367	2	Hexagon nut Sechskantmutter	Tuerca hexagonal Écrou hexagonal	M8	DIN985
677	5000010368	4	Hexagon nut Sechskantmutter	Tuerca hexagonal Écrou hexagonal	M6	DIN985

Engine Compartment
Motorkasten
Caja de Motor
Boîte de Moteur

RTKx-SC3

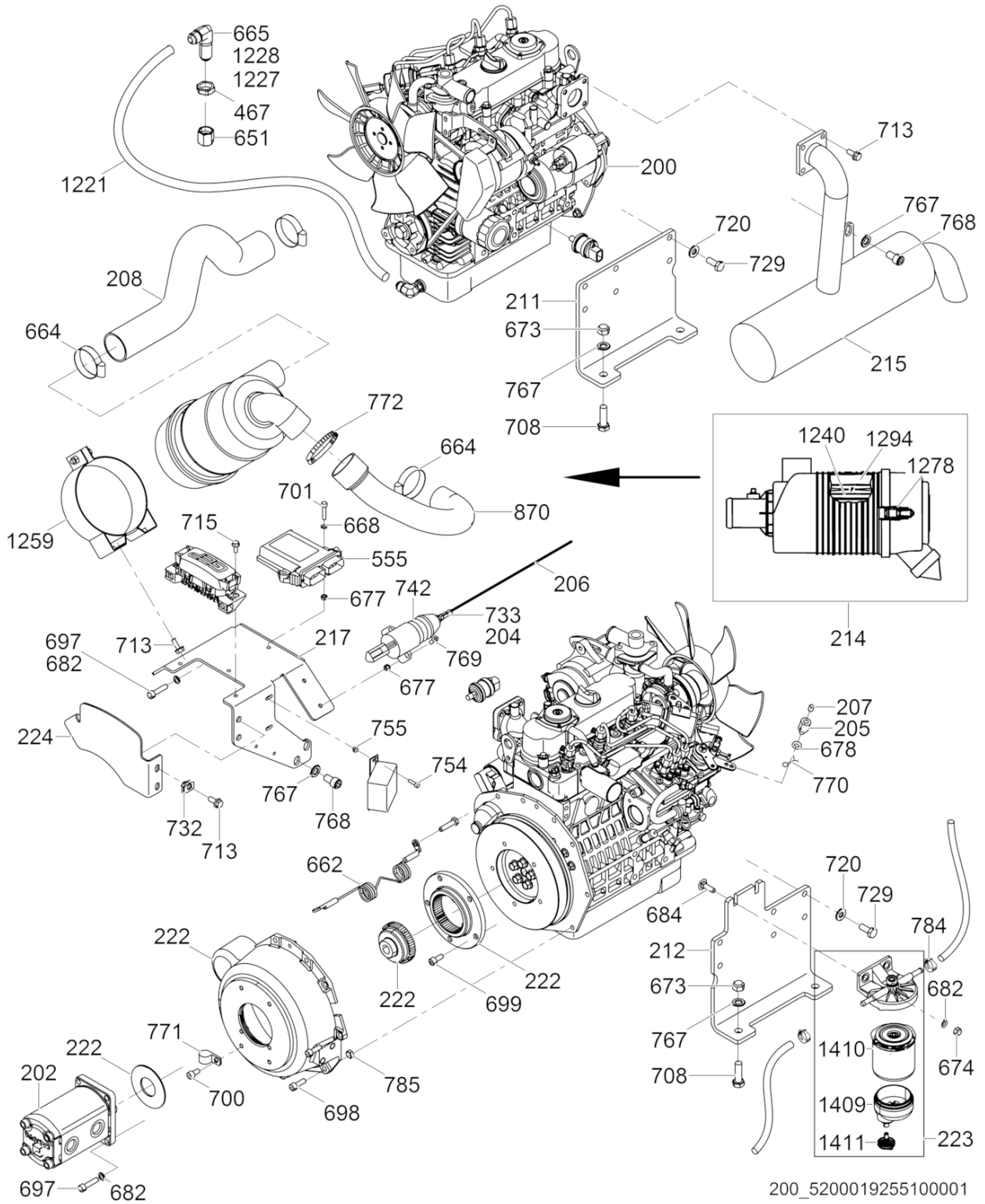

200_5200019255100001

Ref. Pos.	Part No. Artikel Nr.	Qty. St.	Description Beschreibung	Descripción Description	Measurem./Abm.	Norm
					Torque/Drehm.	Sealant Schmierstoff
678	5000010624	1	Flat washer Scheibe	Arandela Rondelle		
682	5000010622	8	Flat washer Scheibe	Arandela Rondelle		
684	5000011151	2	Carriage bolt Schloßschraube	Tornillo de carruaje Boulon brut à tête bombée	M8 x 30	DIN603
688	5000117969	2	Hexagonal head cap screw Sechskantschraube	Tornillo hexagonal Boulon à tête hexagonale	M8 x 45 25Nm/18ft.lbs	
697	5000157151	6	Socket head cap screw Zylinderschraube	Tornillo cilíndrico Vis à tête cylindrique	M8 x 35	
698	5000011542	8	Cheese head screw Zylinderschraube	Tornillo cilíndrico Vis à tête cylindrique	25Nm/18ft.lbs	
699	5000011543	5	Socket head screw Zylinderschraube	Tornillo hueco Vis à six-pans creux	M8 x 20 24Nm/18ft.lbs	ISO4762
700	5000157154	2	Screw-socket head Sechskant-Schraube	Tornillo hueco Vis à six-pans creux	M8 x 16	
701	5000011549	2	Cheese head screw Zylinderschraube	Tornillo cilíndrico Vis à tête cylindrique	M6 x 30 10Nm/7ft.lbs	ISO4762
708	5000016434	4	Screw Schraube	Tornillo Vis	M12 x 40 120Nm/89ft.lbs	
713	5000028404	8	Screw Schraube	Tornillo Vis	M8 x 20 25Nm/18ft.lbs	
715	5000028949	2	Screw Schraube	Tornillo Vis	M6 x 16 10Nm/7ft.lbs	
720	5000033988	12	Lockwasher Spannscheibe	Arandela elástica Rondelle de ressort	10	DIN6796
729	5000011440	12	Hexagonal head cap screw Sechskantschraube	Tornillo hexagonal Vis à tête hexagonale	M10 x 25 49Nm/36ft.lbs	DIN933
732	5000110969	3	Clip nut Klemmutter	Sujetador Agrafe	M8	
733	5000010880	1	Hexagon nut Sechskantmutter	Tuerca hexagonal Écrou hexagonal		
742	5000155486	1	Throttle Actuator Gasreglerstellteil	Actuador de Acelerador Dispositif de commande des gaz		
754	5000011570	2	Cheese head screw Zylinderschraube	Tornillo cilíndrico Vis à tête cylindrique		
755	5000010370	2	Hexagon nut Sechskantmutter	Tuerca hexagonal Écrou hexagonal		
767	5000010620	8	Flat washer Scheibe	Arandela Rondelle	12	ISO7090
768	5000081333	4	Screw Schraube	Tornillo Vis	M12 x 20 145Nm/107ft.lbs	
769	5000011553	2	Cheese head screw Zylinderschraube	Tornillo cilíndrico Vis à tête cylindrique		
770	5000114328	1	Cotter pin Sicherungssplint	Clavija hendida Goupille fendue	1,6 x 16	
771	5000164304	1	Tube clamp Rohrschelle	Abrazadera para mangueras Agrafe pour tuyaux souples	3/4in	
772	5000154344	1	Clamp Schelle	Abrazadera Agrafe		

Engine Compartment
Motorkasten
Caja de Motor
Boîte de Moteur

RTKx-SC3

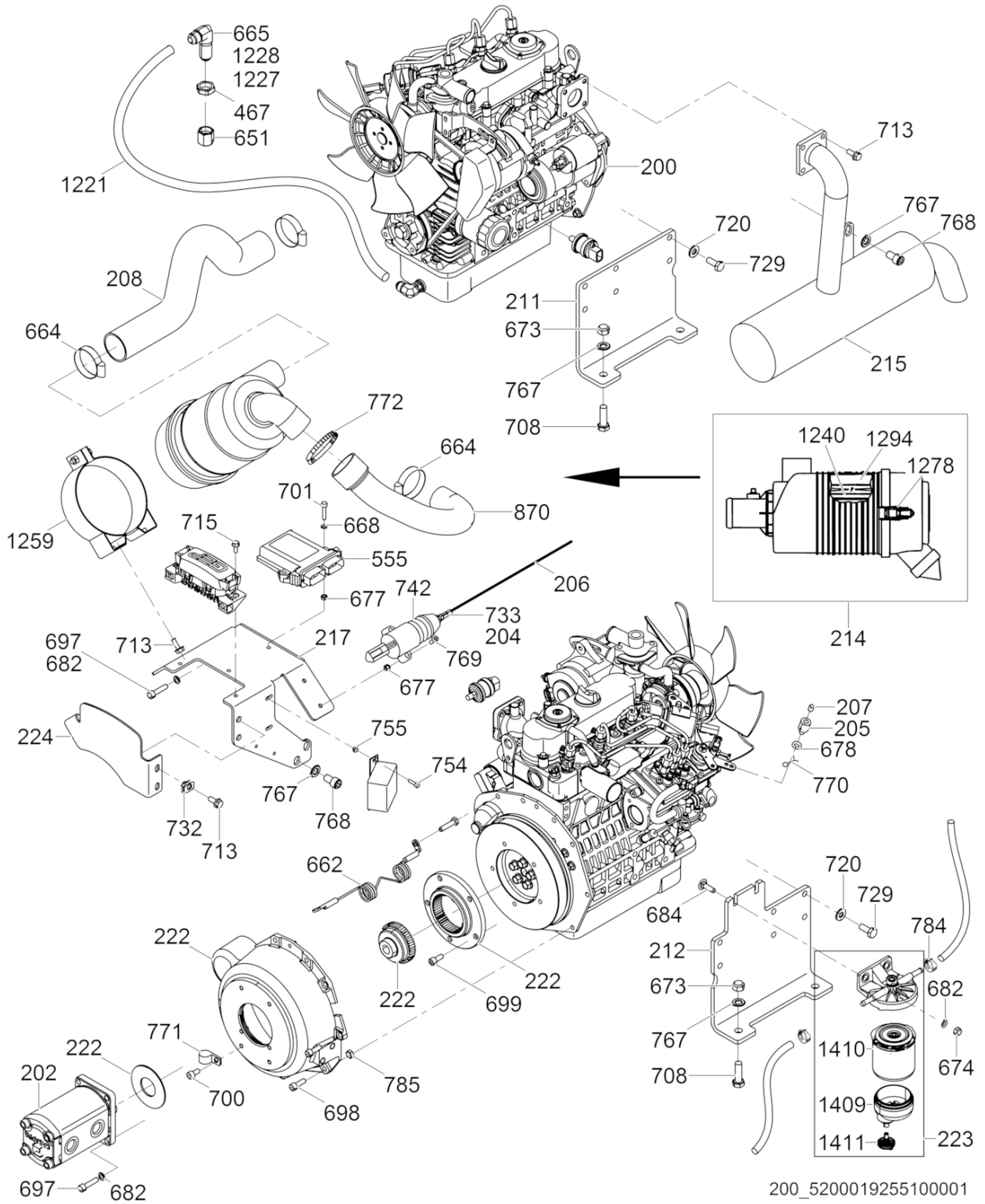

200_5200019255100001

Ref. Pos.	Part No. Artikel Nr.	Qty. St.	Description Beschreibung	Descripción Description	Measurem./Abm.	Norm
					Torque/Drehm.	Sealant Schmierstoff
784	5000028707	4	Clamp Schelle	Abrazadera Agrafe	0,21-0,63	
785	5000010882	7	Hexagon nut Sechskantmutter	Tuerca hexagonal Écrou hexagonal		
870	5200015685	1	Intake manifold hose Einlasskrümmerschlauch	Manguera del distribuidor de admisión Tuyau de collecteur d'admissio		
1221	5000119683	1	Hydraulic hose Hydraulikschlauch	Manguera hidráulica Tuyau hydraulique	380	
1227	5000080737	1	O-Ring O-Ring	Anillo-O Joint torique	0,489 x 0,070in	
1228	5000080732	1	O-Ring O-Ring	Anillo-O Joint torique	0,644 x 0,087in	
1240	5000160171	1	Filter insert Filtereinsatz	Cartucho filtrante Element filtrant		
1259	5000164069	1	Air filter bracket Luftfilterkonsole	Soporte de filtro del aire Support du filtre à air		
1278	5000171456	1	Clamp Klemme	Abrazaderaro de aire Pince		
1294	5000162184	1	Secondary element Sekundärelement	Elemento secundario Cartouche secondaire		
1409	5200025543	1	Bowl Napf	Taza del filtro Ecuelle du filtre		
1410	5200025544	1	Filter element Filterelement	Elemento del filtro Élément du filtre		
1411	5200025545	1	Drain valve Ablassventil	Válvula de vaciado Soupape de drainage		

Front Frame
Vorderrahmen
Basitidor Delantero
Châssis Avant

RTKx-SC3

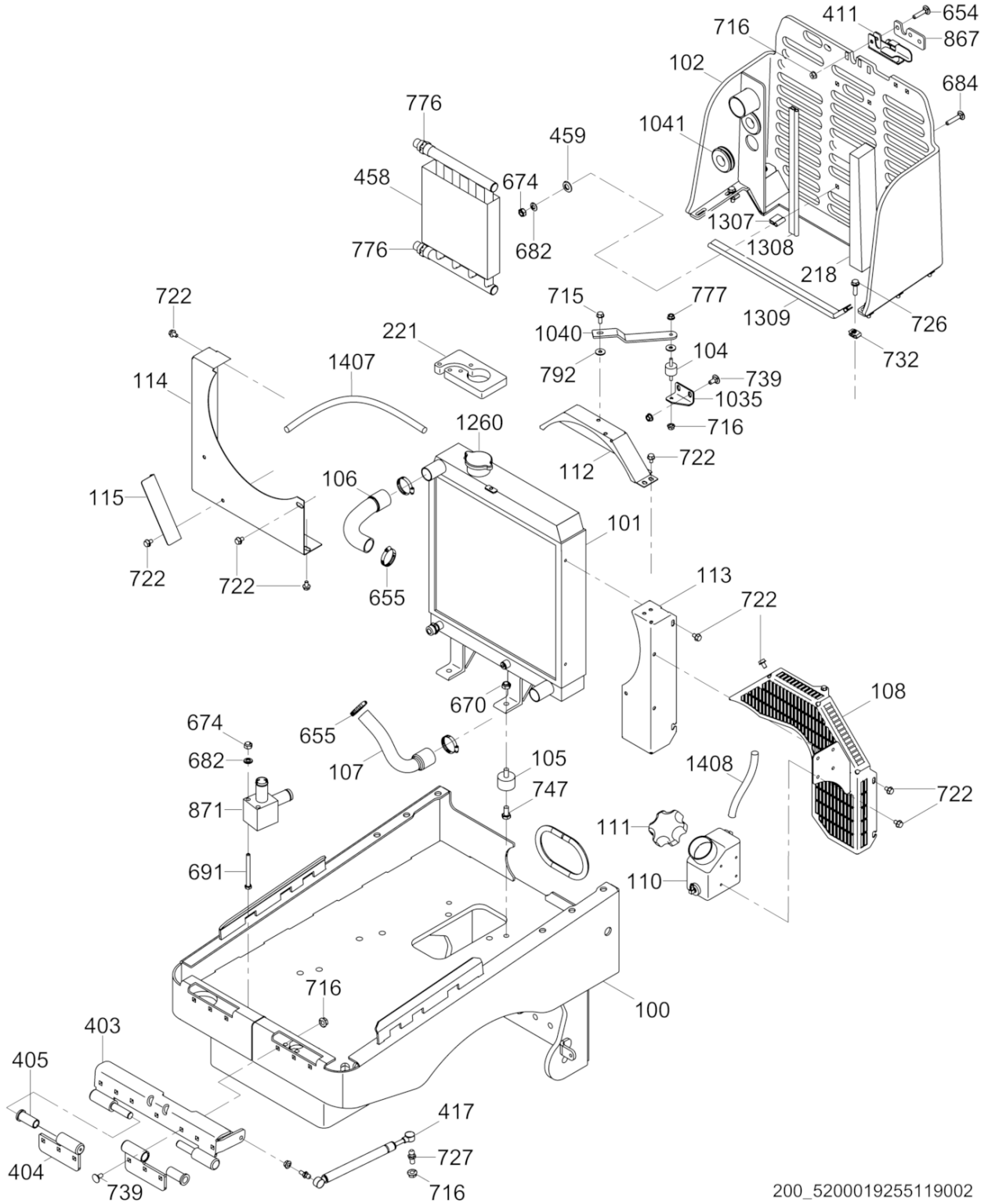

200_5200019255119002

Ref. Pos.	Part No. Artikel Nr.	Qty. St.	Description Beschreibung	Descripción Description	Measurem./Abm.	Norm
					Torque/Drehm.	Sealant Schmierstoff
100	5000116471	1	Front frame Vorderrahmen	Chasis delantero Châssis avant		
101	5000154348	1	Radiator Kühler	Radiador Radiateur		
102	5000177118	1	Radiator guard Kühlerschutzbügel	Guardarradiador Pare-chocs de radiateur		
104	5000150205	1	Shockmount Puffer	Amortiguador Silentbloc	25 x 19-60 Sh	
105	5000150206	2	Shockmount Puffer	Amortiguador Silentbloc	38,1 x 25,4-60 Sh	
106	5200015682	1	Upper radiator hose Oberes Kühlerschlauch	Manguera superior de radiador Tuyau supérieur de radiateur		
107	5200015683	1	Lower radiator hose Unteres Kühlerschlauch	Manguera inferior de radiador Tuyau de radiateur du bas		
108	5200021560	1	Fan guard Lüfterhaube	Guardaventilador Bague de ventilateur		
110	5000157209	1	Bottle-overflow Überlaufflasche	Botella de rebose Bouteille de trop-plein		
111	5000157255	1	Cap Kappe	Tapa Couvercle		
112	5200015663	1	Fan cover Gebläsedeckel	Tapa de ventilador Couvercle de ventilateur		
113	5200015665	1	Fan cover Gebläsedeckel	Tapa de ventilador Couvercle de ventilateur		
114	5200015667	1	Fan cover Gebläsedeckel	Tapa de ventilador Couvercle de ventilateur		
115	5200019631	1	Beltguard Riemenschutz	Guardacorrea Protection de courroie		
218	5000150225	1	Seal Dichtung	Empaque Joint		
221	5000150228	1	Seal Dichtung	Empaque Joint		
403	5000119984	1	Pin Stift	Pasador Goupille		
404	5000181474	2	Hinge Scharnier	Bisagra Charnière		
405	5000164540	2	Bushing spacer Abstandshülse	Espaciador Entretoise		
411	5000150098	1	Latch Verriegelung	Aldaba Loquet		
417	5000150104	1	Cylinder Zylinder	Cilindro Cylindre		
458	5200024880	1	Radiator Kühler	Radiador Radiateur		
459	5000045719	4	Flat washer Scheibe	Arandela Rondelle	8,4	DIN7349
652	5000157166	2	Carriage bolt Schloßschraube	Tornillo de carruaje Boulon brut à tête bombée	M8 x 45	
654	5000119954	3	Carriage bolt Schloßschraube	Tornillo de carruaje Boulon brut à tête bombée	M8 x 40	

Front Frame
Vorderrahmen
Basitidor Delantero
Châssis Avant

RTKx-SC3

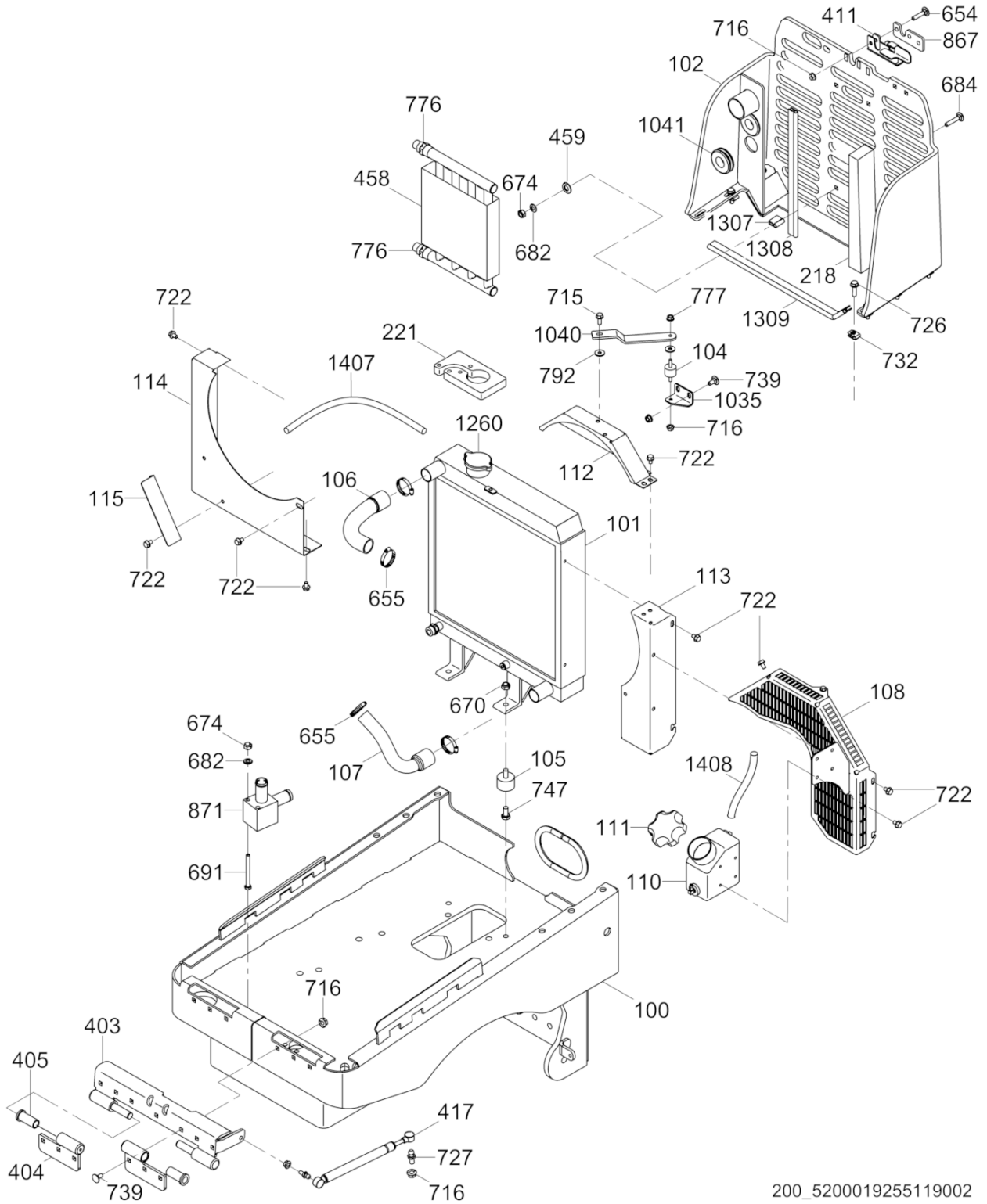

200_5200019255119002

Ref. Pos.	Part No. Artikel Nr.	Qty. St.	Description Beschreibung	Descripción Description	Measurem./Abm.	Norm
					Torque/Drehm.	Sealant Schmierstoff
655	5000119906	4	Hose clamp Schlauchschele	Abrazaderas de manguera Agrafe de tuyau	No.20 x 0,81 x 1,75in	
670	5000010365	2	Lock nut Sicherungsmutter	Contratuerca Contre-écrou	M10	DIN980
674	5000010367	6	Hexagon nut Sechskantmutter	Tuerca hexagonal Écrou hexagonal	M8	DIN985
682	5000010622	4	Flat washer Scheibe	Arandela Rondelle		
684	5000011151	4	Carriage bolt Schloßschraube	Tornillo de carruaje Boulon brut à tête bombée	M8 x 30	DIN603
691	5000011310	2	Hexagonal head cap screw Sechskantschraube	Tornillo hexagonal Vis à tête hexagonale	M8 x 85 25Nm/18ft.lbs	DIN931
716	5000030066	13	Locknut Sechskantmutter	Contratuerca Contre-écrou	M8	
722	5000073164	18	Hexagonal flange head screw Sechskantflanschschaube	Tornillo hexagonal de brida Vis hexagonale de bride	M6 x 10 10Nm/7ft.lbs	
726	5000085957	6	Screw Schraube	Tornillo Vis	M8 x 30 25Nm/18ft.lbs	
727	5000155125	1	Stud Gewindebolzen	Perno prisionero Goujon	M8 x 10	
732	5000110969	6	Clip nut Klemmutter	Sujetador Agrafe	M8	
739	5000155841	8	Carriage bolt Schloßschraube	Tornillo de carruaje Boulon brut à tête bombée	M8 x 20	
747	5000157161	2	Hexagonal head cap screw Sechskantschraube	Tornillo hexagonal Boulon à tête hexagonale	M10 x 20	
776	5000081583	2	Straight fitting Verschraubung-gerade	Unión recto Raccord-droit	No.8	
777	5000029117	1	Lock nut Sicherungsmutter	Contratuerca Contre-écrou	M6	
785	5000010882	2	Hexagon nut Sechskantmutter	Tuerca hexagonal Écrou hexagonal		
792	5000010373	1	Flat washer Scheibe	Arandela Rondelle	6	ISO7093
867	5000160294	1	Spacer Abstandsstück	Espaciador Entretoise		
871	5200017276	1	Suction manifold Saugverteiler	Distribuidor de succión Collecteur d'aspiration		
1035	5000163899	1	Bracket Konsole	Soporte Support		
1040	5200016530	1	Radiator bracket Kühlerträger	Soporte del radiador Support de radiateur		
1041	5000163464	2	Grommet Tülle	Ojal Passe-fil	1 x 1-3/4 x 1/4in	
1260	5000164350	1	Radiator cap Kühlerverschlußdeckel	Tapa del radiador Couvercle du radiateur		
1307	5000159559	1	Seal-trim Profilgummi	Moldura Garniture	1.0in	
1308	5000159560	1	Seal-trim Profilgummi	Moldura Garniture	17in	

Ref. Pos.	Part No. Artikel Nr.	Qty. St.	Description Beschreibung	Descripción Description	Measurement./Abm.	Norm
					Torque/Drehm.	Sealant Schmierstoff
1309	5000159561	1	Seal-trim Profilgummi	Moldura Garniture	1000	
1407	5000114086	1	Fuel hose Kraftstoffleitung	Manguera de combustible Tuyau de carburant	1/4 x 24in	
1408	5000114072	1	Fuel hose Kraftstoffleitung	Manguera de combustible Tuyau de carburant	1-4 x 20-1/2in	

Articulated Steering Joint
Knickgelenk
Unión Articulada de Dirección
Joint articulé

RTKx-SC3

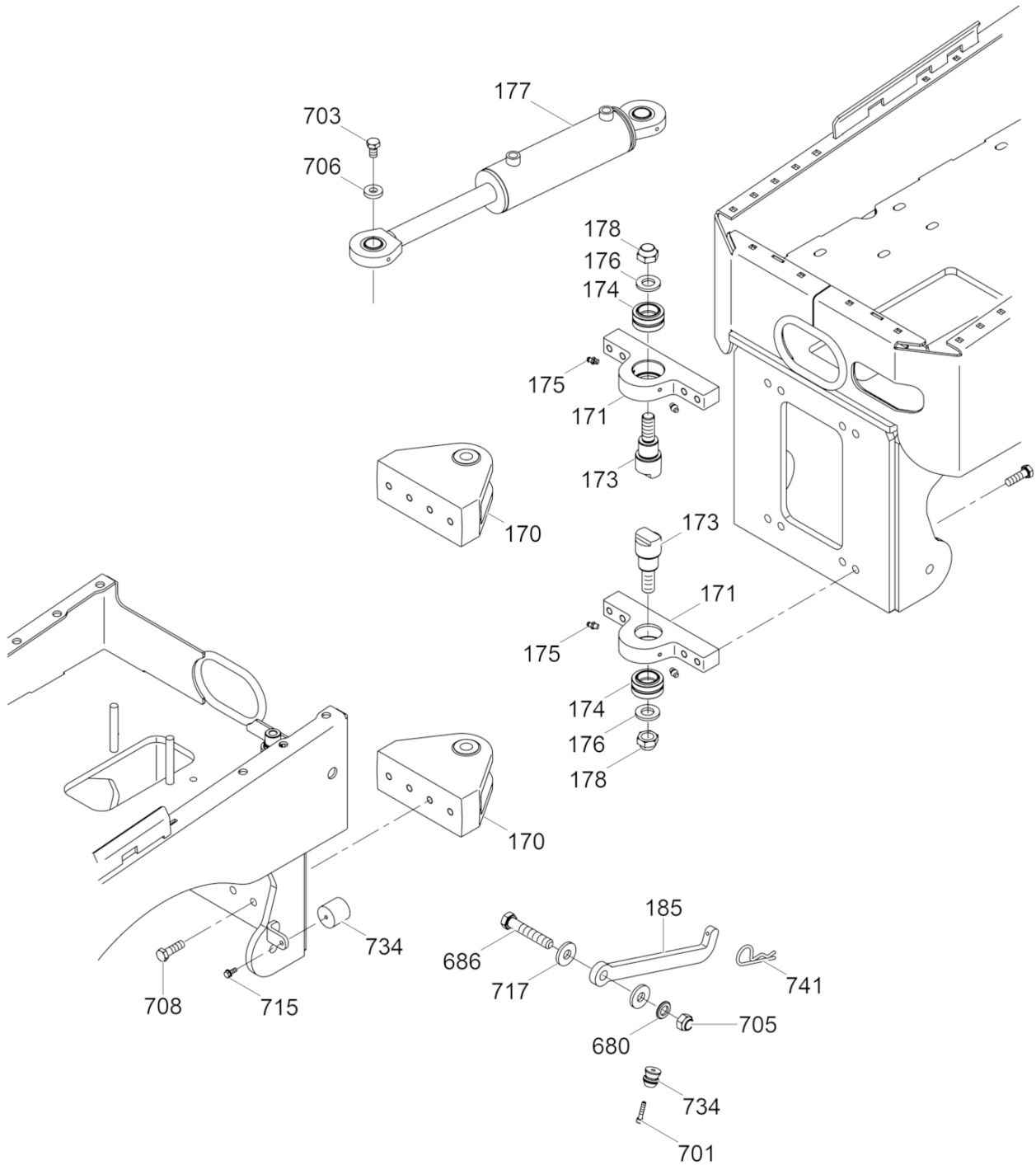

200_5200019255100003

Ref. Pos.	Part No. Artikel Nr.	Qty. St.	Description Beschreibung	Descripción Description	Measurem./Abm.	Norm
					Torque/Drehm.	Sealant Schmierstoff
170	5000115448	2	Pivot Drehteil	Pivote Pivot		
171	5000089323	2	Bracket Konsole	Soporte Support		
173	5000119066	2	Pin Stift	Pasador Goupille		
174	5000079161	2	Ball bearing Kugellager	Rodamiento de bolas Roulement à billes		
175	5002004705	4	Grease fitting Kegelschmiernippel	Grasera Graisseur	AM6	DIN71412
176	5000119067	2	Washer Scheibe	Arandela Rondelle		
177	5000117018	1	Hydraulic cylinder Hydrozylinder	Cilindro hidráulico Cylindre hydraulique		
178	5000017088	2	Lock nut Sicherungsmutter	Contratuercas Contre-écrou	M20	
185	5000119629	1	Lock arm Riegel	Seguro Verrou		
680	5000010618	1	Flat washer Scheibe	Arandela Rondelle	16	ISO7090
686	5000011382	1	Hexagonal head cap screw Sechskantschraube	Tornillo hexagonal Vis à tête hexagonale	M16 x 90 210Nm/155ft.lbs	DIN931
701	5000011549	1	Cheese head screw Zylinderschraube	Tornillo cilíndrico Vis à tête cylindrique	M6 x 30 17Nm/13ft.lbs	ISO4762
703	5000012368	2	Hexagonal head cap screw Sechskantschraube	Tornillo hexagonal Vis à tête hexagonale	M12 x 20 86Nm/63ft.lbs	DIN933 S3
705	5000011382	1	Hexagonal head cap screw Sechskantschraube	Tornillo hexagonal Vis à tête hexagonale	M16 x 90 210Nm/155ft.lbs	DIN931
706	5000013618	2	Flat washer Scheibe	Arandela Rondelle	13	DIN7349
708	5000016434	16	Screw Schraube	Tornillo Vis	M12 x 40 86Nm/63ft.lbs	
715	5000028949	1	Screw Schraube	Tornillo Vis	M6 x 16 10Nm/7ft.lbs	
717	5000031121	2	Washer Scheibe	Arandela Rondelle		
734	5000111536	1	Latch Verriegelung	Aldaba Loquet		
741	5002005276	1	Cotter pin Splint	Clavija hendida Goupille fendue	No.3-9/16in	
1274	5000165049	1	Hose guard Schlauchschutz	Protector de manguera Protecteur		

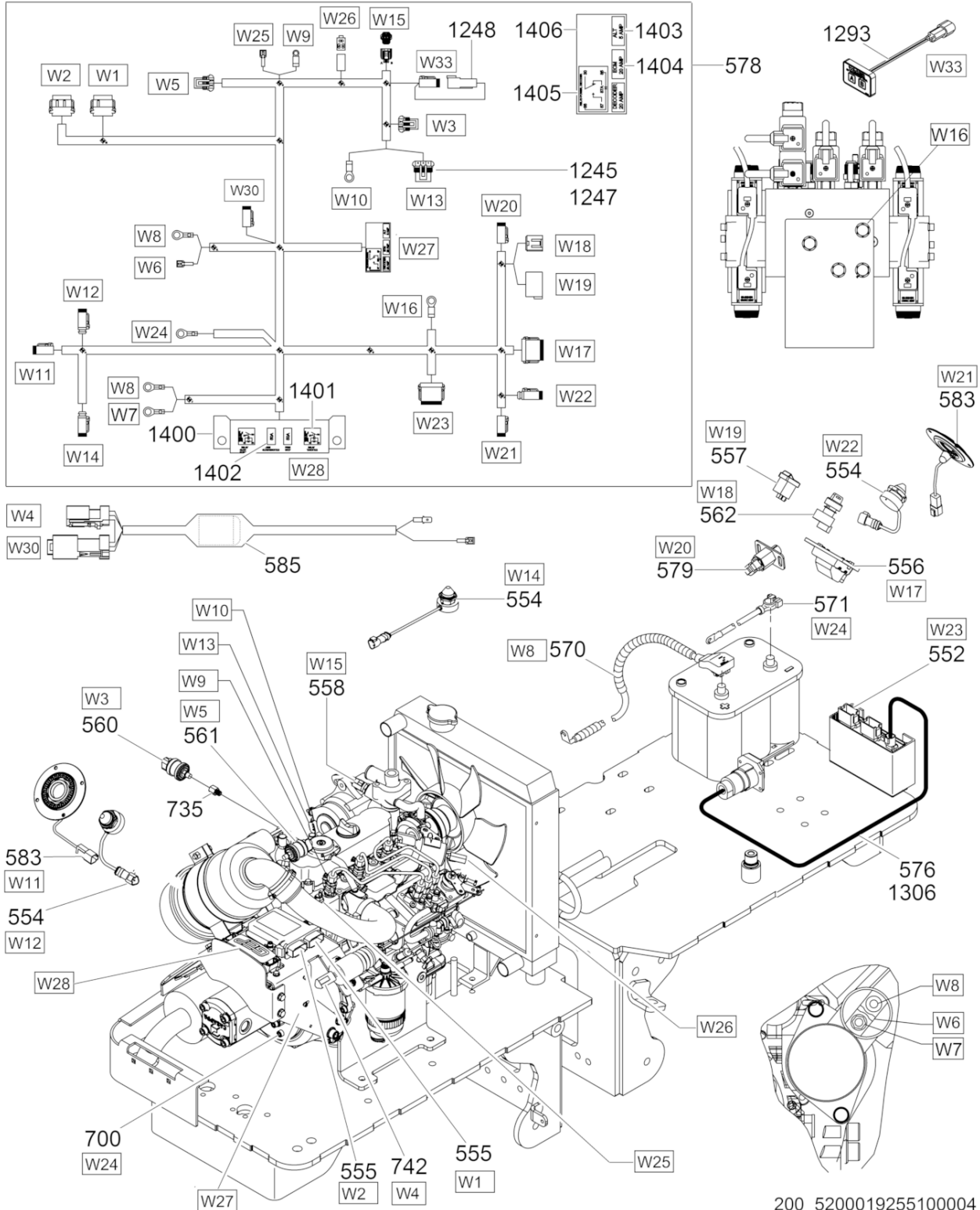

200_5200019255100004

Ref. Pos.	Part No. Artikel Nr.	Qty. St.	Description Beschreibung	Descripción Description	Measurement/Abm.	Norm
					Torque/Drehm.	Sealant Schmierstoff
552	5000165515	1	Decoder module Decodiermodul	Módulo decodificador Module de décodage		
554	5000170949	3	Infrared sensor Empfängerauge	Receptor de rayos Oeil récepteur		
555	5200025081	1	Engine control module Motorkontrollmodul	Módulo de mando del motor Module de contrôle de moteur		
556	5000178862	1	Display module Anzeigemodul	Módulo de visualización Module d'affichage		
557	5000150110	1	Switch Schalter	Interruptor Interrupteur		
558	5100039854	1	Temperature sensor Temperatursensoreinheit	Unidad de alerta de temperatura Appareil d'alerte de températu		
560	5200024858	1	Oil pressure switch Öldruckschalter	Interruptor de presión de aceite Interrupteur à pression d'huile		
561	5000150114	1	Vacuum switch Vakuumschalter	Interruptor Interrupteur à vide		
562	5000150115	1	Ignition switch Zündschalter	Interruptor de encendido Interrupteur d'ignition		
570	5200017874	1	Positive battery cable Plusbatteriekabel	Cable positivo de batería Câble positif de batterie		
571	5200017875	1	Negative battery cable Minusbatteriekabel	Cable negativo de batería Câble négatif de batterie		
576	5000170950	1	Plug and harness cpl. Stecker und Kabelbaum kpl.	Enchufe y conjunto de cables compl. Fiche et harnais de câbles éle		
578	5200016533	1	Engine wiring harness Motorkabelbaum	Conjunto de cables de motor Harnais de câbles électriques		
579	5000154405	1	Charge port module Ladungsanschlussmodul	Módulo de toma de carga Module de prise de charge		
583	5000154403	2	Light ring module Lichtringmodul	Módulo de anillo de luz Module de l'anneau lumineux		
585	5100031355	1	Wiring harness Kabelbaum	Conjunto de cables Harnais de câbles électriques		
585	5000170174	1	Wiring harness Kabelbaum	Conjunto de cables Harnais de câbles électriques		
700	5000157154	1	Screw-socket head Sechskant-Schraube	Tornillo hueco Vis à six-pans creux	M8 x 16	
735	5200018074	1	Adapter fitting Zwischenverschraubung	Unión con adaptador Raccord intermédiaire	1/8 BSPT x 1/8 NPT	
742	5000155486	1	Throttle Actuator Gasreglerstellteil	Actuador de Acelerador Dispositif de commande des gaz		
1245	5000160840	1	Connector housing, 2 pole,plug 2-Pol Stecker	Enchufe Fiche		
1247	5000160842	1	Lock wedge Haltekeil	Cuña de retención Cale de fixation		
1248	5000161278	1	Coolant bypass wiring harness Kabelbaum für Kühlmittelumlauf	Conjunto de cables para desviación del enfriador Harnais de câbles électriques		
1293	5000172989	1	Diagnostic control module Diagnose-Controllermodul	Módulo controlador de diagnóstico Module contrôle de diagnostic		

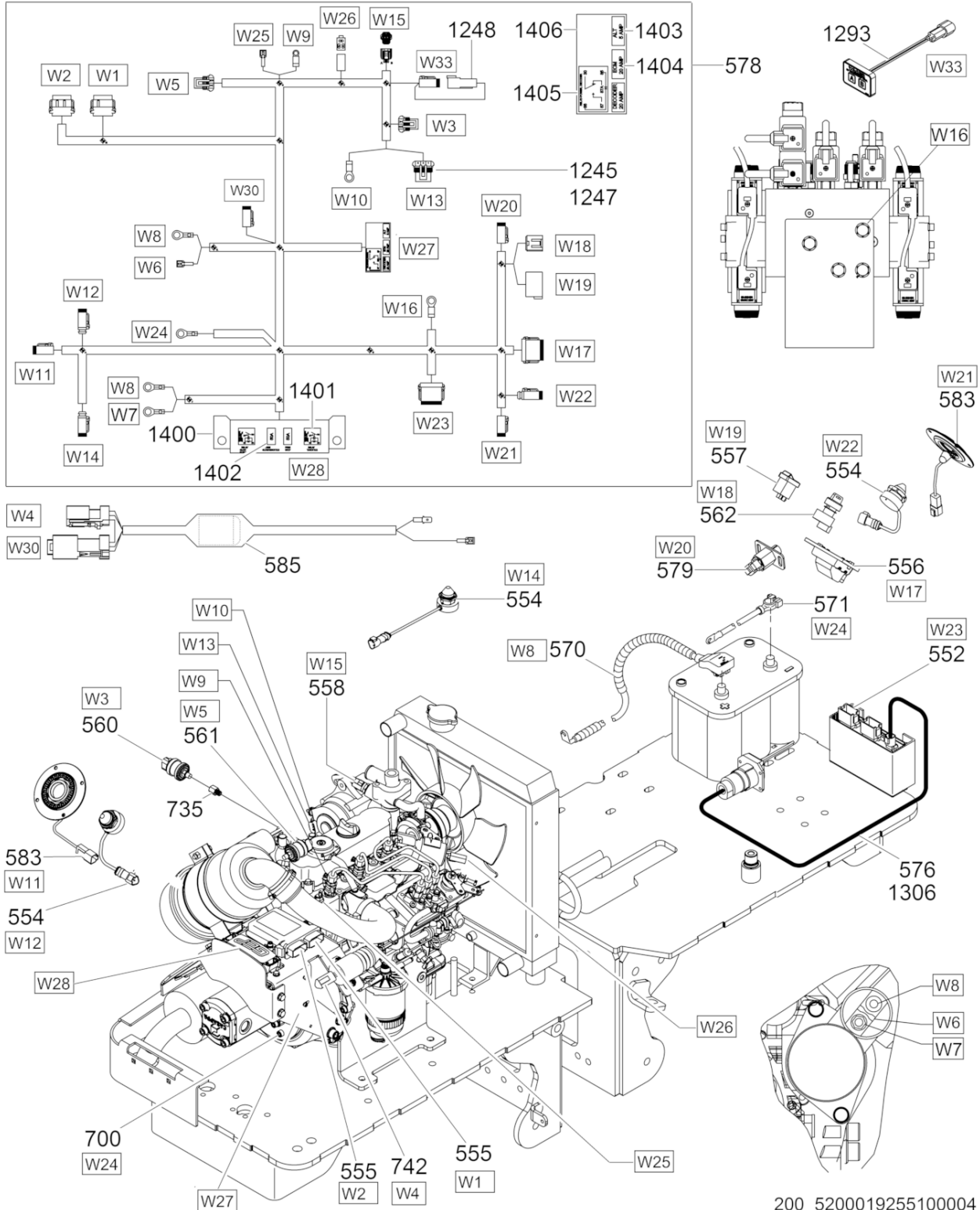

200_5200019255100004

Ref. Pos.	Part No. Artikel Nr.	Qty. St.	Description Beschreibung	Descripción Description	Measurement./Abm.	Norm
					Torque/Drehm.	Sealant Schmierstoff
1306	5000182304	1	Connector Anschlußteil	Conector Connecteur		
1400	5200025185	1	Housing cpl. Gehäuse kpl.	Caja compl. Carter compl.		
1401	5200025184	2	Relay Relais	Relai Relais	12V, 70A	
1402	5000158713	2	Fuse Sicherung	Fusible Fusible	50A	
1403	5200025183	1	Fuse Sicherung	Fusible Fusible	5A	
1404	5000153489	2	Fuse Sicherung	Fusible Fusible	20A	
1405	5200008565	1	Relay Relais	Relai Relais		
1406	5200025190	1	Housing cpl. Gehäuse kpl.	Caja compl. Carter compl.		

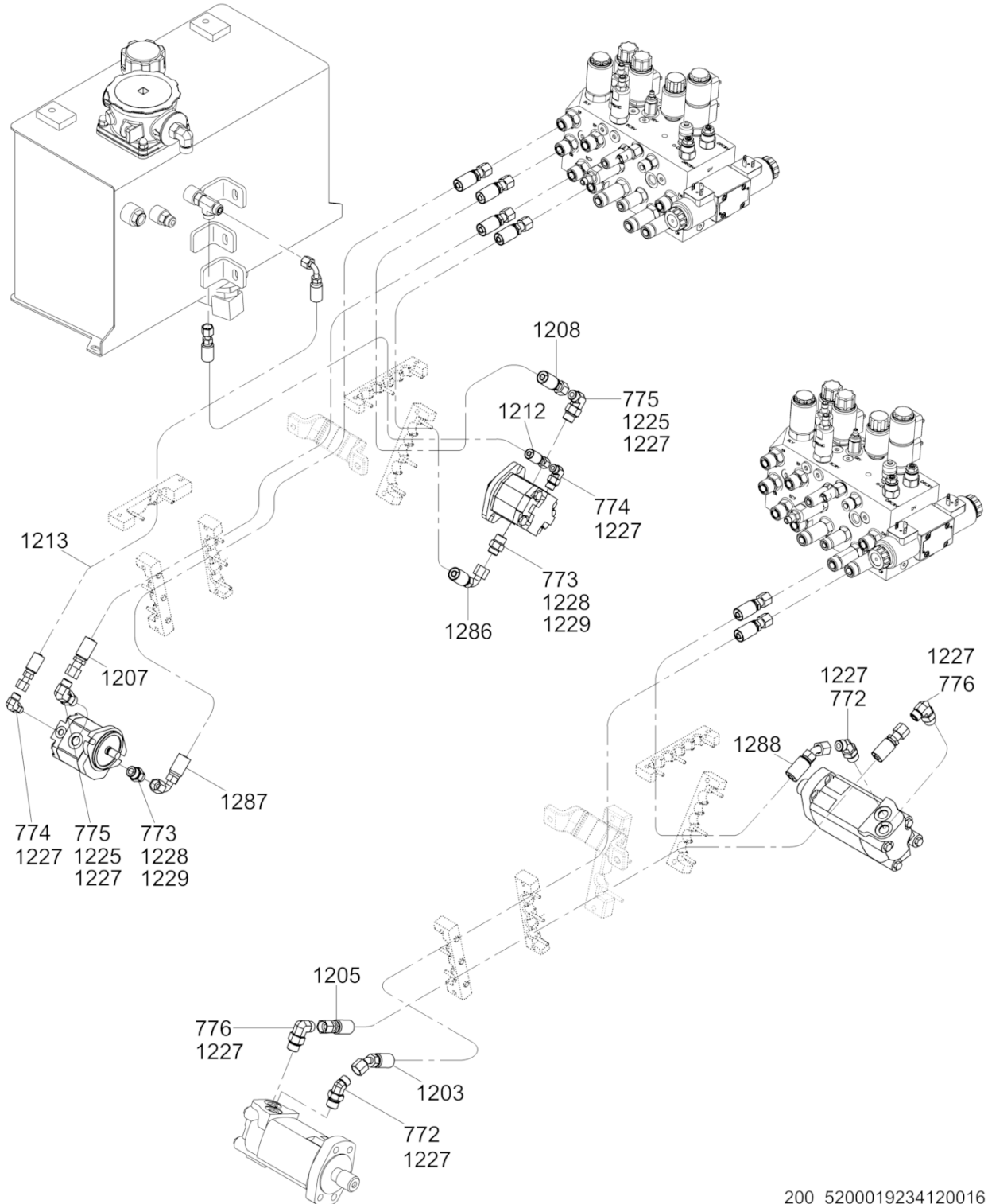

200_5200019234120016

Ref. Pos.	Part No. Artikel Nr.	Qty. St.	Description Beschreibung	Descripción Description	Measurem./Abm.	Norm
					Torque/Drehm.	Sealant Schmierstoff
772	5000151767	4	Hydraulic elbow fitting Hydraulikrohrkrümmer	Codo hidráulico Coude hydraulique	45	S8
773	5000079875	2	Hydraulic fitting Hydraulikverschraubung	Unión hidráulico Raccord hydraulique	No.8 x 10	
774	5000151768	2	Hydraulic elbow fitting Hydraulikrohrkrümmer	Codo hidráulico Coude hydraulique	90	
775	5000081340	2	Elbow fitting Rohrkrümmer	Codo Coude	No.8 x 10 x 90	S8
776	5000081340	2	Elbow fitting Rohrkrümmer	Codo Coude	No.8 x 10 x 90	
1203	5200010939	1	Hydraulic hose Hydraulikschlauch	Manguera hidráulica Tuyau hydraulique	1360	S8
1205	5200010940	1	Hydraulic hose Hydraulikschlauch	Manguera hidráulica Tuyau hydraulique	1275 38Nm/28ft.lbs	S8
1207	5200006474	1	Hydraulic hose Hydraulikschlauch	Manguera hidráulica Tuyau hydraulique	1470 60Nm/44ft.lbs	S8
1208	5200006478	1	Hydraulic hose Hydraulikschlauch	Manguera hidráulica Tuyau hydraulique	995 54Nm/40ft.lbs	S8
1212	5000182222	1	Hydraulic hose Hydraulikschlauch	Manguera hidráulica Tuyau hydraulique	985mm 41Nm/30ft.lbs	S8
1213	5000182221	1	Hydraulic hose Hydraulikschlauch	Manguera hidráulica Tuyau hydraulique	1525mm 41Nm/30ft.lbs	S8
1225	5000080731	5	O-Ring O-Ring	Anillo-O Joint torique	0,468 x 0,078in	
1227	5000080737	16	O-Ring O-Ring	Anillo-O Joint torique	0,489 x 0,070in	
1228	5000080732	8	O-Ring O-Ring	Anillo-O Joint torique	0,644 x 0,087in	
1229	5000080733	2	O-Ring O-Ring	Anillo-O Joint torique	0,755 x 0,097in	
1275	5000170004	1	Protective Hose Kit Schutzschlauchsatz	Juego de Manguera Jue de Tuyau		
1286	5200006554	1	Hydraulic hose Hydraulikschlauch	Manguera hidráulica Tuyau hydraulique	60Nm/44ft.lbs	S8
1287	5200006476	1	Hydraulic hose Hydraulikschlauch	Manguera hidráulica Tuyau hydraulique	1510	
1288	5100014108	1	Hydraulic hose Hydraulikschlauch	Manguera hidráulica Tuyau hydraulique	1060mm	

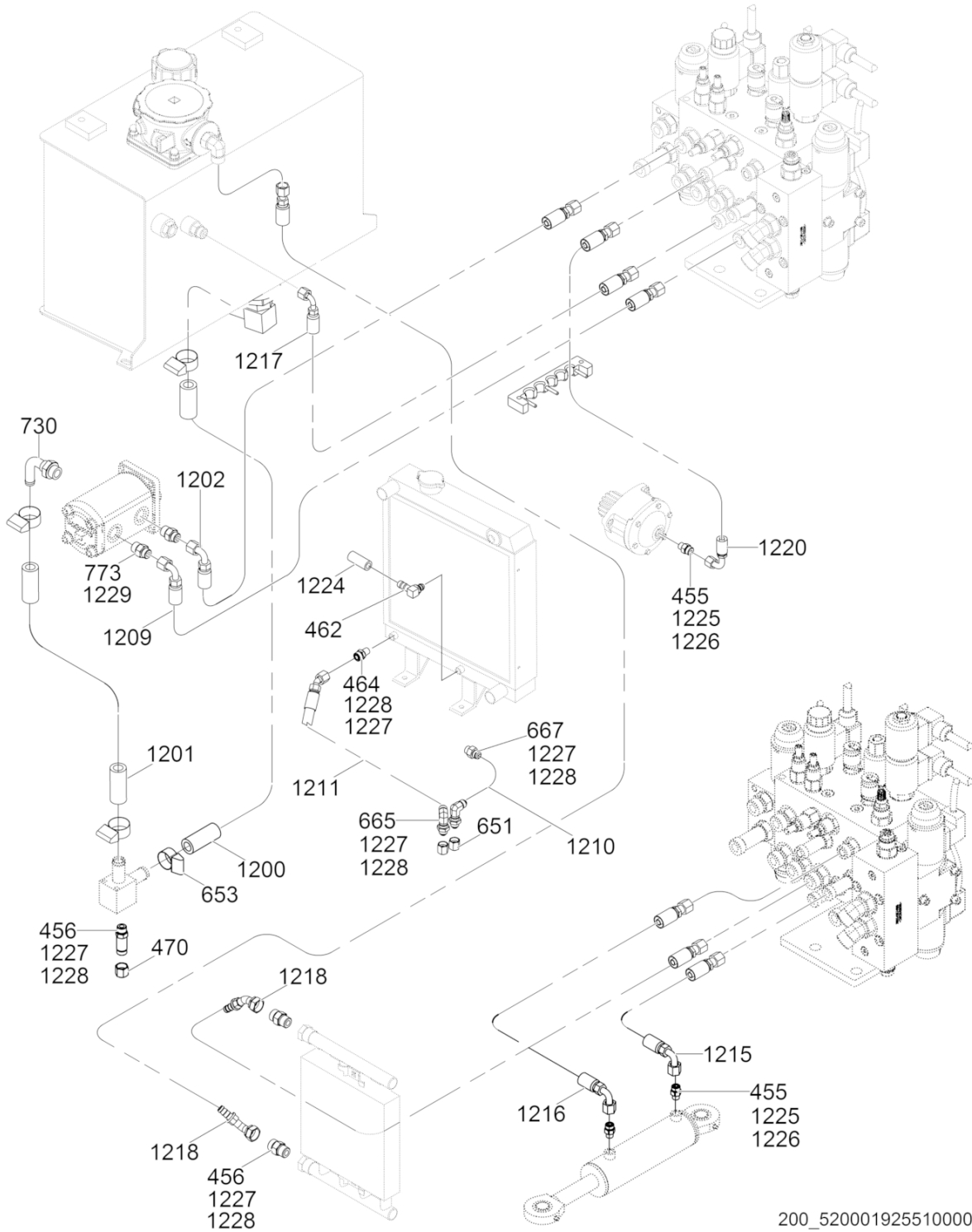

200_5200019255100006

Ref. Pos.	Part No. Artikel Nr.	Qty. St.	Description Beschreibung	Descripción Description	Measurem./Abm.	Norm
					Torque/Drehm.	Sealant Schmierstoff
455	5000078816	3	Adapter fitting Zwischenverschraubung	Unión con adaptador Raccord intermédiaire	41Nm/30ft.lbs	S8
456	5000158572	2	Fitting Verschraubung	Unión Raccord	No.8	
462	5000156401	1	Fitting Verschraubung	Unión Raccord	90	S9
464	5000156204	1	Fitting Verschraubung	Unión Raccord	No.8-3/8 NPT	S9
470	5000111716	1	Cap Kappe	Tapa Capuchon	No.8	
651	5000119929	2	Fitting cap Verschraubung, Kappe	Unión, tapa Raccord, Capuchon	No.8	S8
653	5000150051	2	Hose clamp Schlauchselle	Abrazaderas de manguera Agrafe de tuyau	No.16	
665	5000119960	2	Fitting Verschraubung	Unión Raccord	No.8	S8
667	5000119962	1	Fitting Verschraubung	Unión Raccord	No.8	S8
730	5000088342	2	Fitting Verschraubung	Unión Raccord	90	S8
773	5000079875	2	Hydraulic fitting Hydraulikverschraubung	Unión hidráulico Raccord hydraulique	No.8 x 10	
1200	5000119663	1	Hydraulic hose Hydraulikschlauch	Manguera hidráulica Tuyau hydraulique	1135	
1201	5200017878	1	Hydraulic hose Hydraulikschlauch	Manguera hidráulica Tuyau hydraulique		
1202	5200020055	1	Hydraulic hose Hydraulikschlauch	Manguera hidráulica Tuyau hydraulique	1560	
1209	5200017879	1	Hydraulic hose Hydraulikschlauch	Manguera hidráulica Tuyau hydraulique	1610 60Nm/44ft.lbs	
1210	5200017910	1	Drain hose Abflussschlauch	Manguera de salida Tuyau d'écoulement		
1211	5200020054	1	Drain hose Abflussschlauch	Manguera de salida Tuyau d'écoulement		
1215	5000182223	1	Hydraulic hose Hydraulikschlauch	Manguera hidráulica Tuyau hydraulique	285mm 41Nm/30ft.lbs	S8
1216	5000182636	1	Hydraulic hose Hydraulikschlauch	Manguera hidráulica Tuyau hydraulique	450mm	S8
1217	5000182224	1	Hydraulic hose Hydraulikschlauch	Manguera hidráulica Tuyau hydraulique	425mm 41Nm/30ft.lbs	S8
1218	5000164955	2	Hydraulic hose Hydraulikschlauch	Manguera hidráulica Tuyau hydraulique		
1220	5000182225	1	Hydraulic hose Hydraulikschlauch	Manguera hidráulica Tuyau hydraulique	590mm 41Nm/30ft.lbs	S8
1224	5000119934	1	Drain hose Abflussschlauch	Manguera de salida Tuyau d'écoulement	570	S8
1225	5000080731	5	O-Ring O-Ring	Anillo-O Joint torique	0,468 x 0,078in	
1226	5000080736	3	O-Ring O-Ring	Anillo-O Joint torique	0,364 x 0,070in	

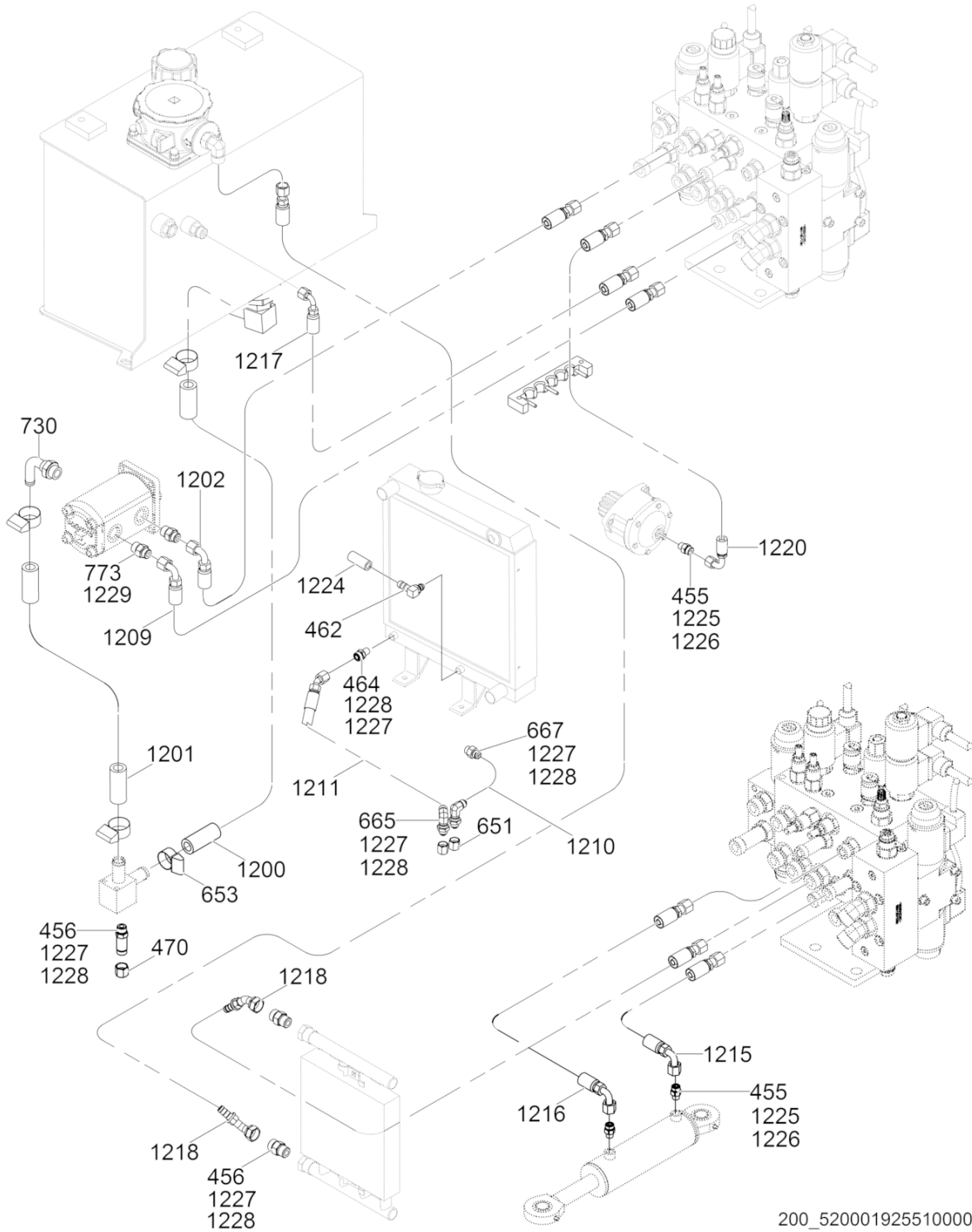

200_5200019255100006

Ref. Pos.	Part No. Artikel Nr.	Qty. St.	Description Beschreibung	Descripción Description	Measurement./Abm.	Norm
					Torque/Drehm.	Sealant Schmierstoff
1227	5000080737	16	O-Ring O-Ring	Anillo-O Joint torique	0,489 x 0,070in	
1228	5000080732	8	O-Ring O-Ring	Anillo-O Joint torique	0,644 x 0,087in	
1229	5000080733	2	O-Ring O-Ring	Anillo-O Joint torique	0,755 x 0,097in	
1275	5000170004	1	Protective Hose Kit Schutzschlauchsatz	Juego de Manguera Jue de Tuyau		

Rear Frame
Hinterrahmen
Bastidor de Atrás
Châssis Arrière

RTKx-SC3

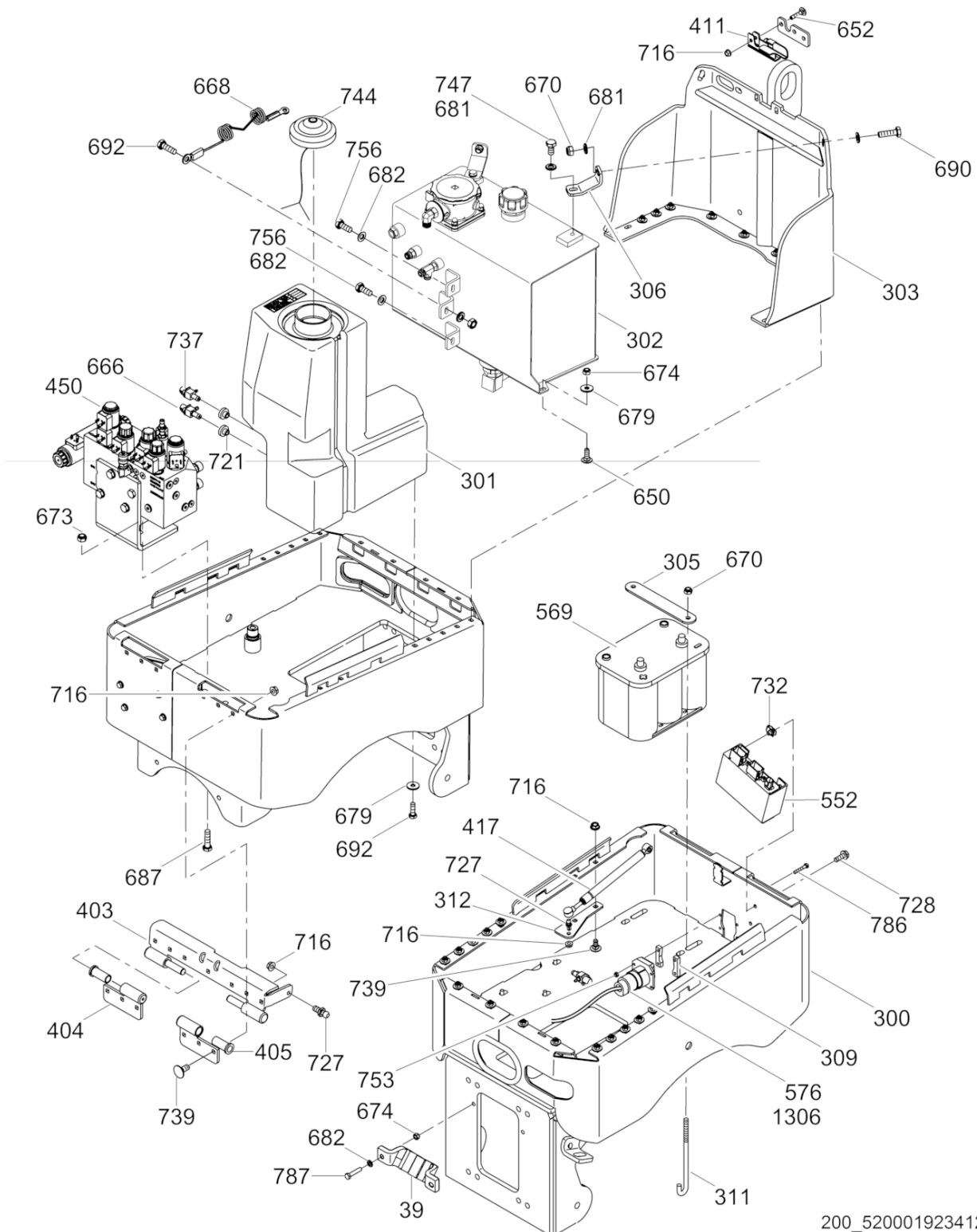

200_5200019234120003

Ref. Pos.	Part No. Artikel Nr.	Qty. St.	Description Beschreibung	Descripción Description	Measurement./Abm.	Norm
					Torque/Drehm.	Sealant Schmierstoff
39	5100035870	1	Hose guide bracket Schlauchführungshalter	Support de guidage de tuyau Soporte de la manguera		
300	5000117176	1	Rear frame Hinterrahmen	Chasis de atrás Châssis arrière		
301	5000153625	1	Fuel tank Kraftstofftank	Depósito de combustible Réservoir de carburant		
302	5200000844	1	Hydraulic tank Hydrauliktank	Tanque hidráulico Réservoir hydraulique		
303	5000150089	1	Housing Gehäuse	Caja Carter		
305	5000152305	1	Plate Platte	Placa Plaque		
306	5000154260	1	Bracket Konsole	Soporte Support		
309	5000154751	1	Spacer Abstandsstück	Espaciador Entretoise		
311	5000156164	2	Rod Stange	Varilla Tringle		
312	5000154712	1	Bracket Konsole	Soporte Support		
403	5000119984	1	Pin Stift	Pasador Goupille		
404	5000181474	2	Hinge Scharnier	Bisagra Charnière		
405	5000164540	2	Bushing spacer Abstandshülse	Espaciador Entretoise		
411	5000150098	1	Latch Verriegelung	Aldaba Loquet		
417	5000150104	1	Cylinder Zylinder	Cilindro Cylindre		
450	5200025568	1	Hydraulic manifold Hydraulikverteiler	Distribuidor hidráulico Tubulure hydraulique		
552	5000165515	1	Decoder module Decodiermodul	Módulo decodificador Module de décodage		
569	5000165552	1	Battery Batterie	Batería Batterie	12V	
576	5000170950	1	Plug and harness cpl. Stecker und Kabelbaum kpl.	Enchufe y conjunto de cables compl. Fiche et harnais de câbles éle		
650	5000157165	14	Carriage bolt Schloßschraube	Tornillo de carruaje Boulon brut à tête bombée	M8 X 25 8,8	
652	5000157166	3	Carriage bolt Schloßschraube	Tornillo de carruaje Boulon brut à tête bombée	M8 x 45	
666	5000119927	1	Fitting Verschraubung	Unión Raccord	1/4in	
668	5000154402	1	Cable Kabel	Cable Câble		
670	5000010365	4	Lock nut Sicherungsmutter	Contratuerca Contre-écrou	M10	DIN980
673	5000010366	4	Hexagon nut Sechskantmutter	Tuerca hexagonal Écrou hexagonal	M12X1.75	DIN985

Rear Frame
Hinterrahmen
Bastidor de Atrás
Châssis Arrière

RTKx-SC3

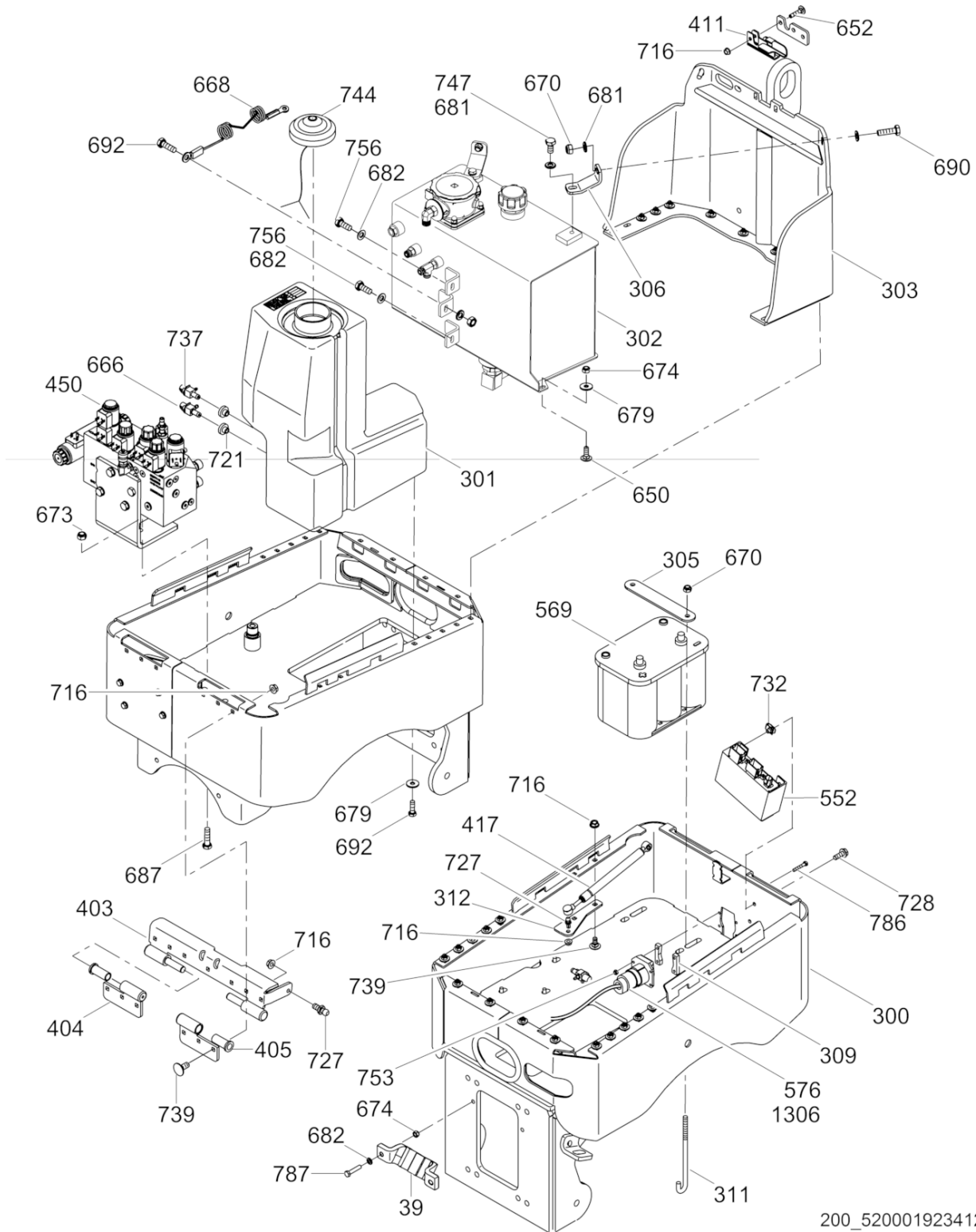

200_5200019234120003

Ref. Pos.	Part No. Artikel Nr.	Qty. St.	Description Beschreibung	Descripción Description	Measurement./Abm.	Norm
					Torque/Drehm.	Sealant Schmierstoff
674	5000010367	2	Hexagon nut Sechskantmutter	Tuerca hexagonal Écrou hexagonal	M8	DIN985
679	5000160298	6	Flat washer Scheibe	Arandela elástica Rondelle de ressort	B8.4	
681	5000010621	6	Washer Scheibe	Arandela Rondelle		
682	5000010622	4	Flat washer Scheibe	Arandela Rondelle		
687	5000011420	4	Hexagonal head cap screw Sechskantschraube	Tornillo hexagonal Vis à tête hexagonale	M12 x 45 86Nm/63ft.lbs	DIN933
690	5000011438	2	Hexagonal head cap screw Sechskantschraube	Tornillo hexagonal Vis à tête hexagonale	M10 x 35 49Nm/36ft.lbs	DIN933
692	5000011457	6	Hexagonal head cap screw Sechskantschraube	Tornillo hexagonal Vis à tête hexagonale	M8 x 25 7Nm/5ft.lbs	DIN933 S3
716	5000030066	12	Locknut Sechskantmutter	Contratuerca Contre-écrou	M8 7Nm/5ft.lbs	
721	5000053577	2	Tank valve bushing Tankbuchse	Buje Douille		
727	5000155125	2	Stud Gewindebolzen	Perno prisionero Goujon	M8 x 10	
728	5000087023	4	Hexagonal flange head screw Sechskantflanschschaube	Tornillo hexagonal de brida Vis hexagonale de bride	M8 x 22 25Nm/18ft.lbs	
732	5000110969	4	Clip nut Klemmutter	Sujetador Agrafe	M8	
737	5000157189	1	Valve Ventil	Válvula Soupape	3/16in	
739	5000155841	8	Carriage bolt Schloßschraube	Tornillo de carruaje Boulon brut à tête bombée	M8 x 20	
744	5000118640	1	Fuel tank cap Tankverschluss	Tapa del tanque Chapeau de réservoir		
747	5000012364	1	Hexagonal head cap screw Sechskantschraube	Tornillo hexagonal Vis à tête hexagonale	M10 x 20 49Nm/36ft.lbs	DIN933 S3
753	5000010369	4	Hexagon nut Sechskantmutter	Tuerca hexagonal Écrou hexagonal		
756	5000012362	2	Hexagonal head cap screw Sechskantschraube	Tornillo hexagonal Vis à tête hexagonale	7Nm/5ft.lbs	
786	5000154898	4	Hexagonal head cap screw Sechskantschraube	Tornillo hexagonal Boulon à tête hexagonale	M5 x 30	
867	5000160294	1	Spacer Abstandsstück	Espaciador Entretoise		
1306	5000182304	1	Connector Anschlußteil	Conector Connecteur		

Front Cover
 Vorderdeckel
 Tapa delantera
 Couvercle avant

RTKx-SC3

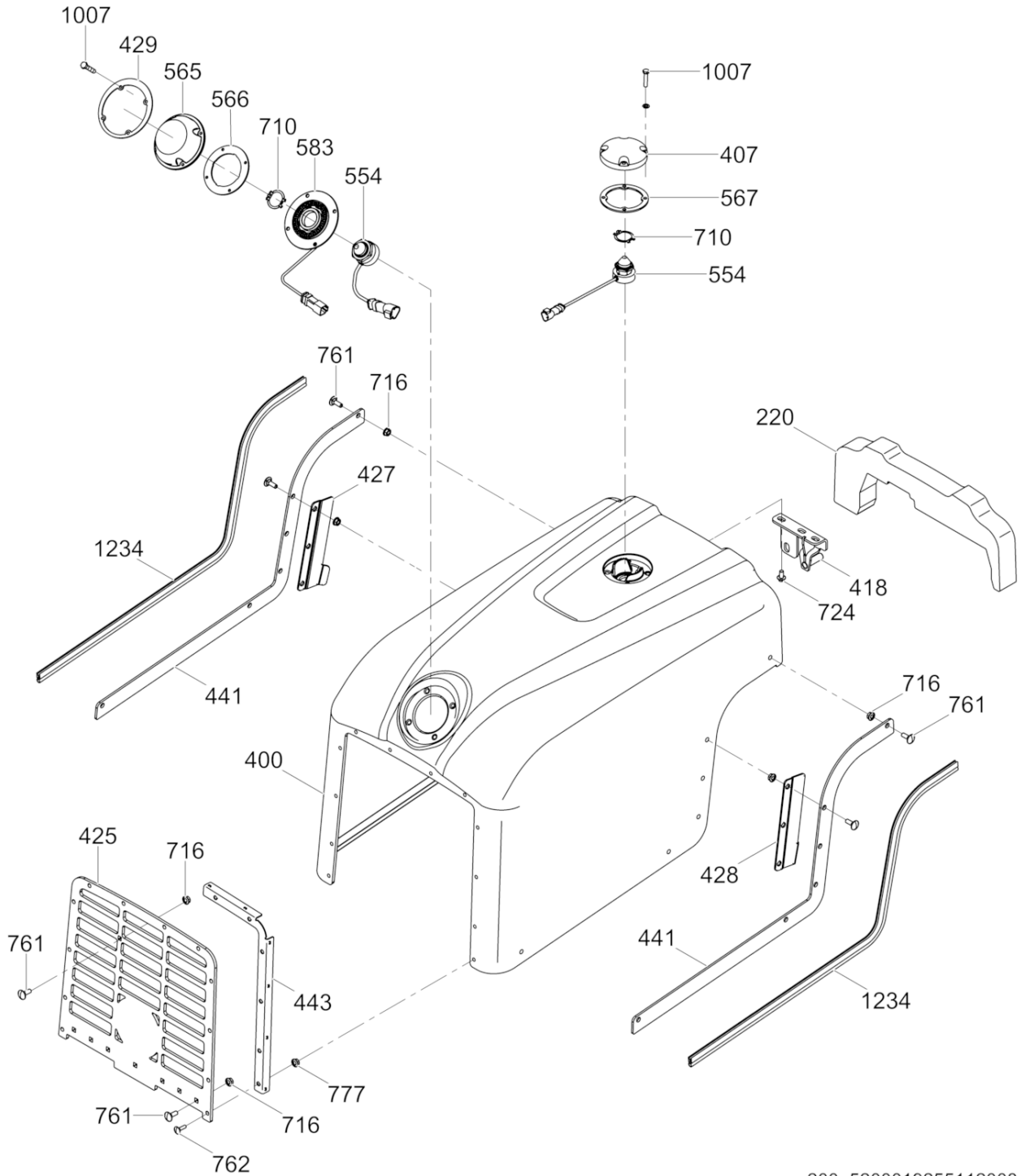

200_5200019255112008

Ref. Pos.	Part No. Artikel Nr.	Qty. St.	Description Beschreibung	Descripción Description	Measurem./Abm.	Norm
					Torque/Drehm.	Sealant Schmierstoff
220	5000150227	1	Seal Dichtung	Empaque Joint		
220	5200019759	1	Trim seal Profilgummi	Moldura Garniture		
400	5200017704	1	Front cover Vorderdeckel	Tapa delantera Couvercle avant		
407	5200018182	1	Cap Kappe	Tapa Capuchon		
418	5200019751	1	Bracket Konsole	Soporte Support		
425	5200019770	1	Grille cover Gitter	Rejilla Grille		
427	5200019757	1	Bracket Konsole	Soporte Support		
428	5200019758	1	Bracket Konsole	Soporte Support		
429	5200019775	1	Ring Ring	Anillo Anneau		
441	5200019755	2	Bracket Konsole	Soporte Support		
443	5200019774	1	Bracket Konsole	Soporte Support		
554	5000170949	2	Infrared sensor Empfängerauge	Receptor de rayos Oeil récepteur		
565	5200011851	1	Cap Kappe	Tapa Capuchon		
566	5100026695	1	Gasket Dichtung	Junta Joint		
567	5100026696	1	Gasket Dichtung	Junta Joint		
583	5000154403	1	Light ring module Lichtringmodul	Módulo de anillo de luz Module de l'anneau lumineux		
710	5000172857	2	Retaining washer Scheibe	Arandela Rondelle		
716	5000030066	20	Locknut Sechskantmutter	Contratuerca Contre-écrou	M8	
724	5000155839	3	Hexagonal head cap screw Sechskantschraube	Tornillo hexagonal Boulon à tête hexagonale	M8 x 16	
761	5000163950	20	Carriage bolt Schloßschraube	Tornillo de carruaje Boulon brut à tête bombée	M8 x 25	
762	5000164579	12	Carriage bolt Schloßschraube	Tornillo de carruaje Boulon brut à tête bombée	M6 x 25	
777	5000029117	12	Lock nut Sicherungsmutter	Contratuerca Contre-écrou	M6	
1007	5000011474	8	Hexagonal head cap screw Sechskantschraube	Tornillo hexagonal Vis à tête hexagonale	M5 x 25 6Nm/4ft.lbs	DIN933 S3
1234	5000159561	2	Seal-trim Profilgummi	Moldura Garniture	1000	

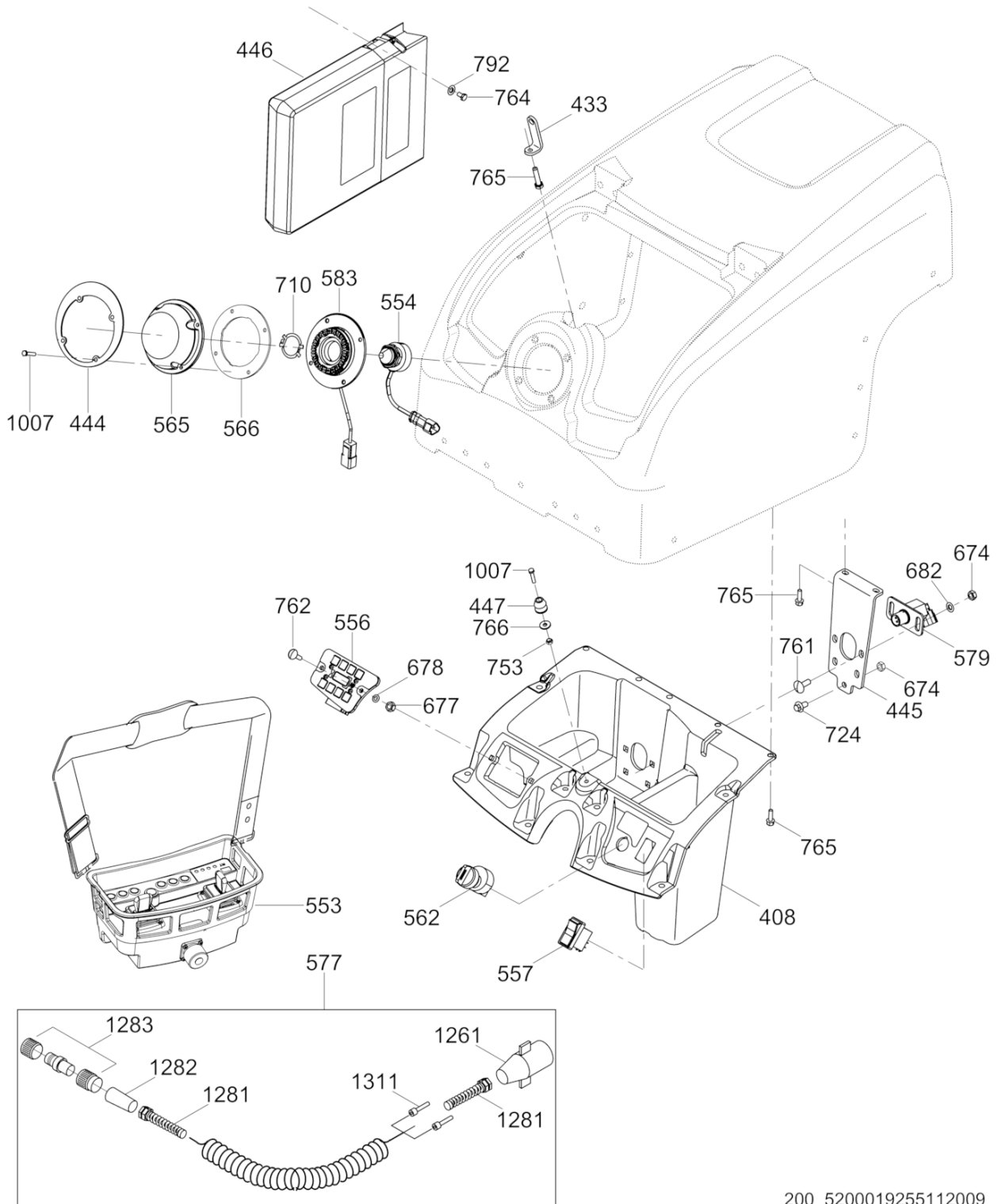

200_5200019255112009

Ref. Pos.	Part No. Artikel Nr.	Qty. St.	Description Beschreibung	Descripción Description	Measurem./Abm.	Norm
					Torque/Drehm.	Sealant Schmierstoff
408	5200018183	1	Console Bedienungskonsole	Pupitre de mando Panneau de contrôle		
433	5200019786	1	Tab Zunge	Orejeta Onglet		
444	5200019779	1	Mount Konsole	Ménsula Support		
445	5200019784	1	Bracket Konsole	Soporte Support		
446	5000153425	1	Manual holder Handbuchhalter	Soporte manual Support de manuel		
447	5000170979	1	Door latch Türverriegelung	Aldaba de puerta Loquet de porte		
553	5000165514	1	Transmitter module Sender	Transmisor Transmetteur		
554	5000170949	2	Infrared sensor Empfängerauge	Receptor de rayos Oeil récepteur		
556	5000178862	1	Display module Anzeigemodul	Módulo de visualización Module d'affichage		
557	5000150110	1	Switch Schalter	Interruptor Interrupteur		
562	5000150115	1	Ignition switch Zündschalter	Interruptor de encendido Interrupteur d'ignition		
565	5200011851	1	Cap Kappe	Tapa Capuchon		
566	5100026695	1	Gasket Dichtung	Junta Joint		
577	5000154417	1	Charging cable Ladungskabel	Cable de carga Câble de charge		
579	5000178854	1	Charge port module Ladungsanschlussmodul	Módulo de toma de carga Module de prise de charge		
583	5000154403	1	Light ring module Lichtringmodul	Módulo de anillo de luz Module de l'anneau lumineux		
674	5000010367	4	Hexagon nut Sechskantmutter	Tuerca hexagonal Écrou hexagonal	M8	DIN985
677	5000010368	2	Hexagon nut Sechskantmutter	Tuerca hexagonal Écrou hexagonal	M6	DIN985
678	5000010624	2	Flat washer Scheibe	Arandela Rondelle		
682	5000010622	2	Flat washer Scheibe	Arandela Rondelle		
710	5000172857	1	Retaining washer Scheibe	Arandela Rondelle		
724	5000155839	3	Hexagonal head cap screw Sechskantschraube	Tornillo hexagonal Boulon à tête hexagonale	M8 x 16	
753	5000010369	1	Hexagon nut Sechskantmutter	Tuerca hexagonal Écrou hexagonal		
761	5000163950	4	Carriage bolt Schloßschraube	Tornillo de carruaje Boulon brut à tête bombée	M8 x 25	
762	5000164579	2	Carriage bolt Schloßschraube	Tornillo de carruaje Boulon brut à tête bombée	M6 x 25	

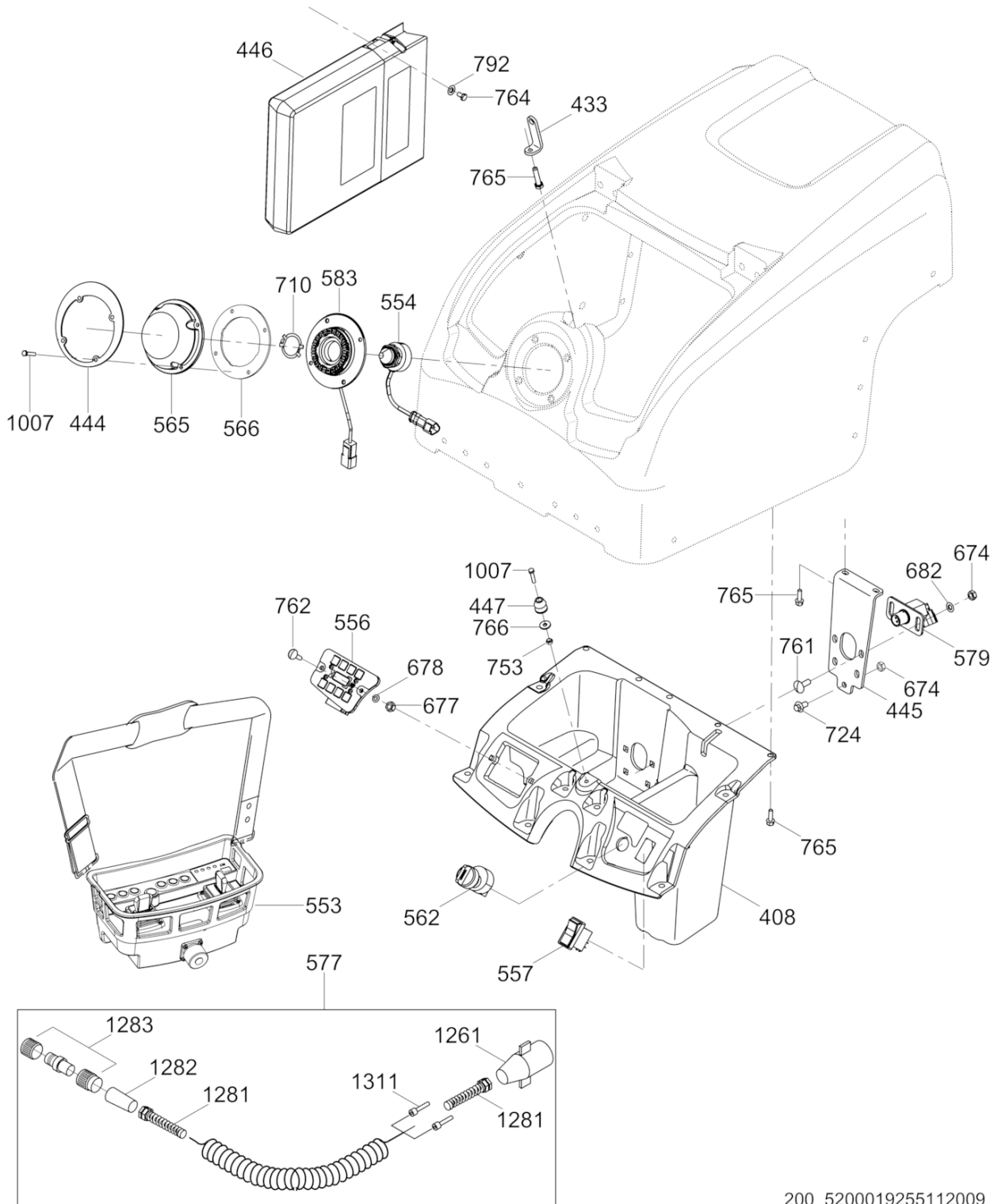

200_5200019255112009

Ref. Pos.	Part No. Artikel Nr.	Qty. St.	Description Beschreibung	Descripción Description	Measurement./Abm.	Norm
					Torque/Drehm.	Sealant Schmierstoff
764	5000012356	4	Hexagonal head cap screw Sechskantschraube	Tornillo hexagonal Vis à tête hexagonale	M6 x 10 10Nm/7ft.lbs	DIN933
765	5200020974	1	Hexagonal flange head screw Sechskantflanschschaube	Tornillo hexagonal de brida Vis hexagonale de bride	M6 x 20 10Nm/7ft.lbs	
766	5000010372	1	Flat washer Scheibe	Arandela Rondelle	B5,3	DIN9021
792	5000010373	4	Flat washer Scheibe	Arandela Rondelle	6	ISO7093
1007	5000011474	5	Hexagonal head cap screw Sechskantschraube	Tornillo hexagonal Vis à tête hexagonale	M5 x 25 6Nm/4ft.lbs	DIN933 S3
1261	5000164490	1	Plug connector (9 pin) 9-Stift Anschlussstecker	Enchufe de (9 agujas) Fiche à (9 broches)		
1281	5000089676	2	Strain relief Zugentlastung	Alivio de esfuerzos Effort à la décharge		
1282	5000088821	1	Adaptor Adapter	Adaptador Adaptateur		
1283	5000116889	1	Plug cpl. Stopfen kpl.	Tapón compl Bouchon compl		
1311	5100037420	2	Pin terminal Stiftklemme	Terminal de pasador Épingle terminal		

Rear Cover
Hinterdeckel
Tapa de atrás
Couvercle arrière

RTKx-SC3

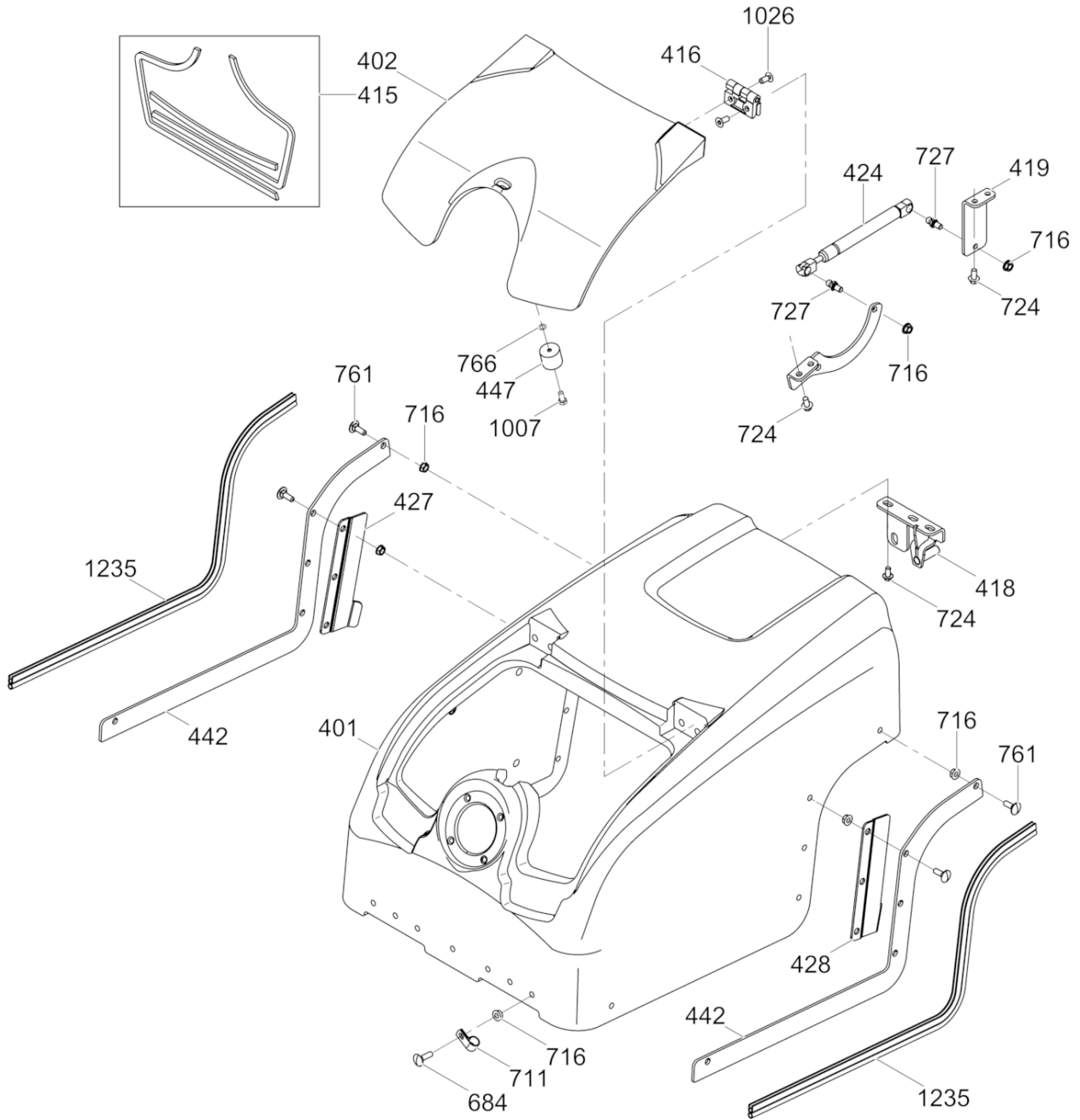

200_5200019255100010

Ref. Pos.	Part No. Artikel Nr.	Qty. St.	Description Beschreibung	Descripción Description	Measurement/Abm.	Norm
					Torque/Drehm.	Sealant Schmierstoff
401	5200017705	1	Rear cover Hinterdeckel	Tapa de atrás Couvercle arrière		
402	5200017707	1	Access cover Abdeckplatte	Tapa de acceso Couvercle à accès		
415	5200023550	1	Gasket Set Dichtungssatz	Juego de juntas Jeu de joints		
416	5000154400	2	Hinge Scharnier	Bisagra Charnière		
418	5200019751	1	Bracket Konsole	Soporte Support		
419	5200019783	1	Bracket Konsole	Soporte Support		
424	5000154401	1	Cylinder Zylinder	Cilindro Cylindre		
427	5200019757	1	Bracket Konsole	Soporte Support		
428	5200019758	1	Bracket Konsole	Soporte Support		
442	5200019756	2	Bracket Konsole	Soporte Support		
447	5000170979	1	Door latch Türverriegelung	Aldaba de puerta Loquet de porte		
684	5000011151	7	Carriage bolt Schloßschraube	Tornillo de carruaje Boulon brut à tête bombée	M8 x 30	DIN603
711	5000163956	1	Clamp Schelle	Abrazadera Agrafe		
711	5000163957	1	Tube clamp Rohrschelle	Abrazadera para mangueras Agrafe pour tuyaux souples	5/16in ID	
716	5000030066	19	Locknut Sechskantmutter	Contratuercas Contre-écrou	M8	
724	5000155839	7	Hexagonal head cap screw Sechskantschraube	Tornillo hexagonal Boulon à tête hexagonale	M8 x 16	
727	5000155125	1	Stud Gewindebolzen	Perno prisionero Goujon	M8 x 10	
761	5000163950	10	Carriage bolt Schloßschraube	Tornillo de carruaje Boulon brut à tête bombée	M8 x 25	
766	5000010372	1	Flat washer Scheibe	Arandela Rondelle	B5,3	DIN9021
1007	5000011474	1	Hexagonal head cap screw Sechskantschraube	Tornillo hexagonal Vis à tête hexagonale	M5 x 25 6Nm/4ft.lbs	DIN933
1026	5000021563	8	Countersunk screw Senkschraube	Tornillo avellanado Vis noyée	M8 x 20 25Nm/18ft.lbs	ISO10642
1235	5000159562	2	Seal-trim Profilgummi	Moldura Garniture	822	

**Drum Drive
Bandagenantrieb**

RTKx-SC3

**Accionamiento de Tambor
Entraînement de Tambour**

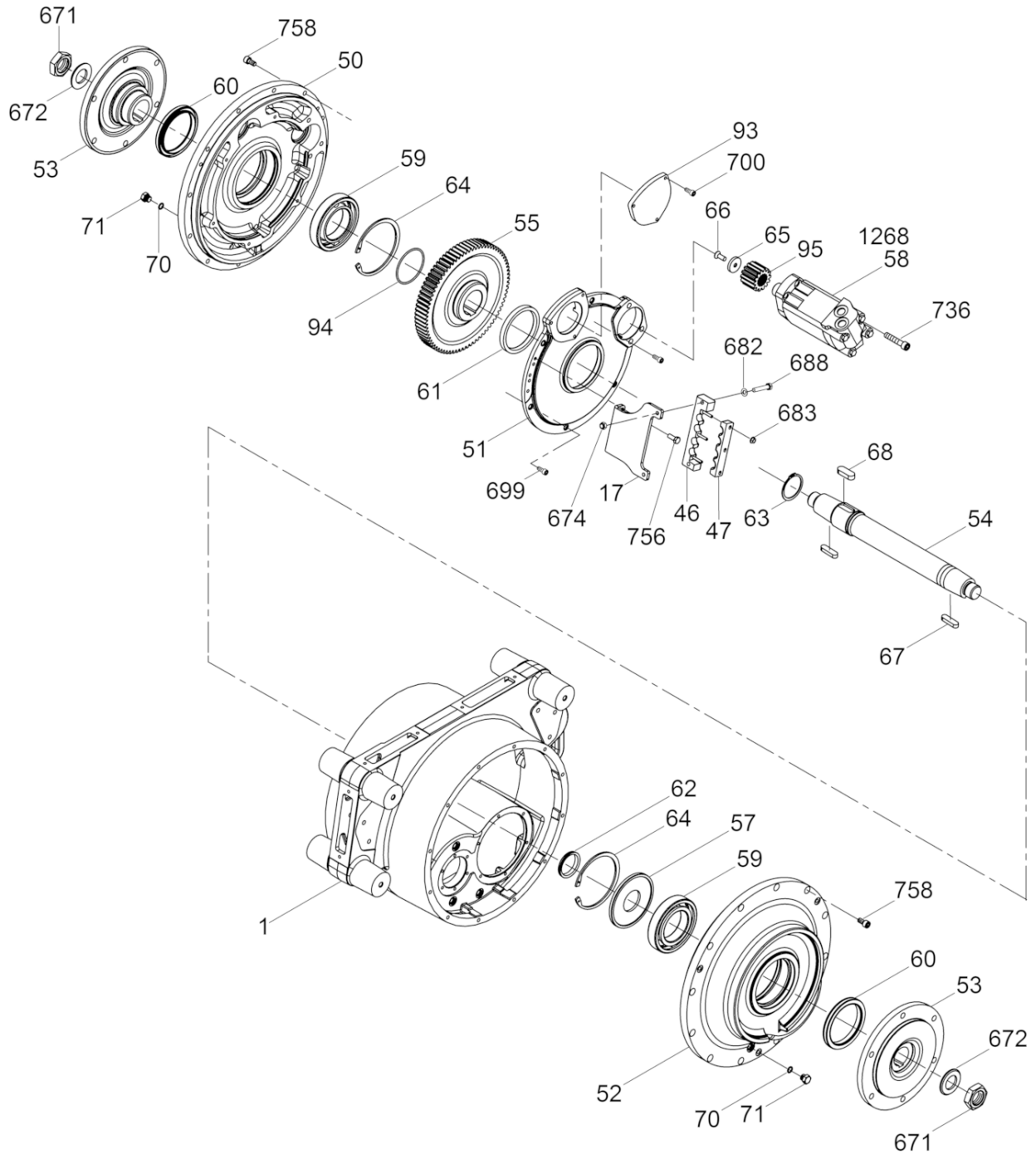

200_5200019255100011

Ref. Pos.	Part No. Artikel Nr.	Qty. St.	Description Beschreibung	Descripción Description	Measurem./Abm.	Norm
					Torque/Drehm.	Sealant Schmierstoff
1	5000116902	1	Drum support Bandagenträger	Soporte del tambor Support de tambour		
17	5200007278	1	Bracket Konsole	Soporte Support		
46	5000150252	1	Hose clamp Schlauchschele	Abrazaderas de manguera Agrafe de tuyau		
47	5000150253	1	Hose clamp Schlauchschele	Abrazaderas de manguera Agrafe de tuyau		
50	5000118366	1	Cover Deckel	Tapa Couvercle		
51	5000118368	1	Cover Deckel	Tapa Couvercle		
52	5000116903	1	Cover Deckel	Tapa Couvercle		
53	5000116906	2	Drum hub Bandagennabe	Maza de tambor Moyeu de tambour		
54	5000116907	1	Drive shaft Antriebswelle	Eje motor Arbre d'entraînement		
55	5000119284	1	Gear Zahnrad	Engranaje Engrenage		
57	5000118796	1	Disc Scheibe	Disco Disque		
58	5000181899	1	Drive motor Antriebsmotor	Motor de accionamiento Moteur d'entraînement		
59	5000082961	2	Roller bearing Rollenlager	Rodamiento de rodillos Roulement à rouleaux		
60	5000119285	2	Seal Dichtung	Empaque Joint		
61	5000116874	1	Shaft seal Wellendichtring	Sello del eje Bague d'étanchéité	100 x 120 x 12	
62	5000119286	1	Shaft seal Wellendichtring	Sello del eje Bague d'étanchéité		
63	5000116869	1	Retaining ring Sicherungsring	Anillo de retención Bague d'arrêt	62 x 2	DIN471
64	5000044706	2	Retaining ring Sicherungsring	Anillo de retención Bague d'arrêt	140 x 4	DIN472
65	5000080666	1	Washer Scheibe	Arandela Rondelle		
66	5000080667	1	Screw Schraube	Tornillo Vis	3/8-16 x 1in	S3
67	5000116872	2	Square key Passfeder	Chaveta Clavette	A14 x 9 x 50	DIN6885
68	5000116873	1	Square key Passfeder	Chaveta Clavette	A18 x 11 x 50	DIN6885
70	5000014398	2	O-Ring O-Ring	Anillo-O Joint torique	12 x 2	
71	5000078269	2	Plug (threaded) Schraubverschluß	Tapón roscado Bouchon	9/16-18in	
93	5000119505	1	Plate Platte	Placa Plaque		

**Drum Drive
Bandagenantrieb**

RTKx-SC3

**Accionamiento de Tambor
Entraînement de Tambour**

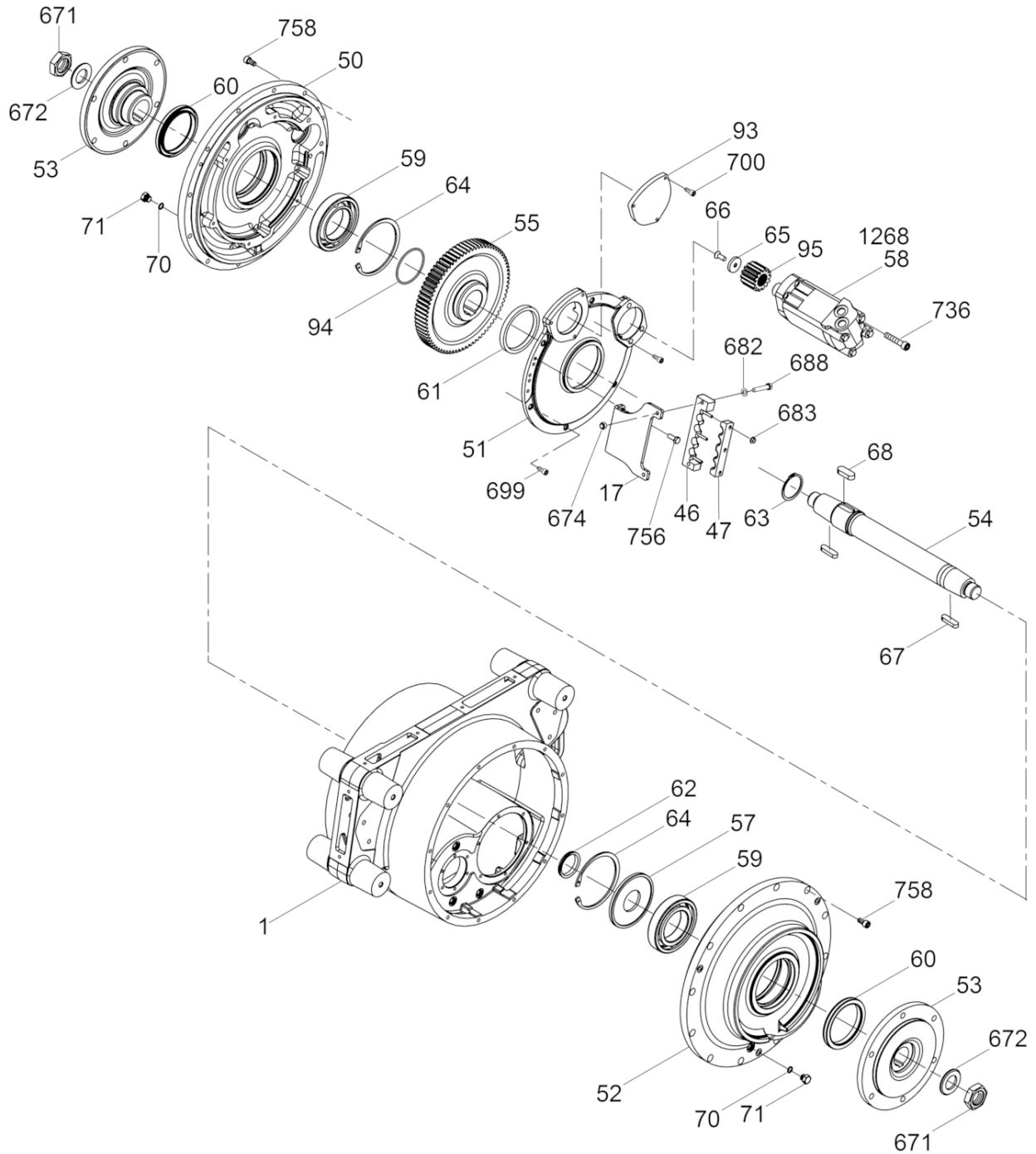

200_5200019255100011

Ref. Pos.	Part No. Artikel Nr.	Qty. St.	Description Beschreibung	Descripción Description	Measurem./Abm.	Norm
					Torque/Drehm.	Sealant Schmierstoff
94	5000152276	1	O-Ring O-Ring	Anillo-O Joint torique	81,92 x 5,33	
95	5000154482	1	Pinion gear Ritzel	Piñon diferencial Pignon		
671	5000116871	2	Nut Mutter	Tuerca Écrou	M36 x 3 825Nm/609ft.lbs	S3
672	5000150020	2	Washer Scheibe	Arandela Rondelle	M36	
674	5000010367	2	Hexagon nut Sechskantmutter	Tuerca hexagonal Écrou hexagonal	M8	DIN985
682	5000010622	2	Flat washer Scheibe	Arandela Rondelle		
683	5000155519	3	Flange nut Flanschmutter	Tuerca de reborde Ecrou de bride	M6	DIN 1661
688	5000117969	2	Hexagonal head cap screw Sechskantschraube	Tornillo hexagonal Boulon à tête hexagonale	M8 x 45 25Nm/18ft.lbs	
699	5000011543	5	Socket head screw Zylinderschraube	Tornillo hueco Vis à six-pans creux	M8 x 20 25Nm/18ft.lbs	ISO4762
700	5000011544	3	Cheese head screw Zylinderschraube	Tornillo cilíndrico Vis à tête cylindrique	M8 x 16 41Nm/30ft.lbs	ISO4762 S3
736	5000111979	3	Socket head cap screw Zylinderschraube	Tornillo cilíndrico Vis à tête cylindrique	M12 x 60 85Nm/63ft.lbs	ISO4762 S4
756	5000012362	3	Hexagonal head cap screw Sechskantschraube	Tornillo hexagonal Vis à tête hexagonale		
758	5000072758	30	Cheese head screw Zylinderschraube	Tornillo cilíndrico Vis à tête cylindrique	M10 x 20 49Nm/36ft.lbs	ISO4762 S3
1268	5000182756	1	Seal Kit Dichtungssatz	Juego-empaque Jeu-joint		

Drum Drive w/Brake
Bandagenantrieb mit Bremse

RTKx-SC3

Accionamiento de Tambor con Freno
Entraînement de Tambour avec F

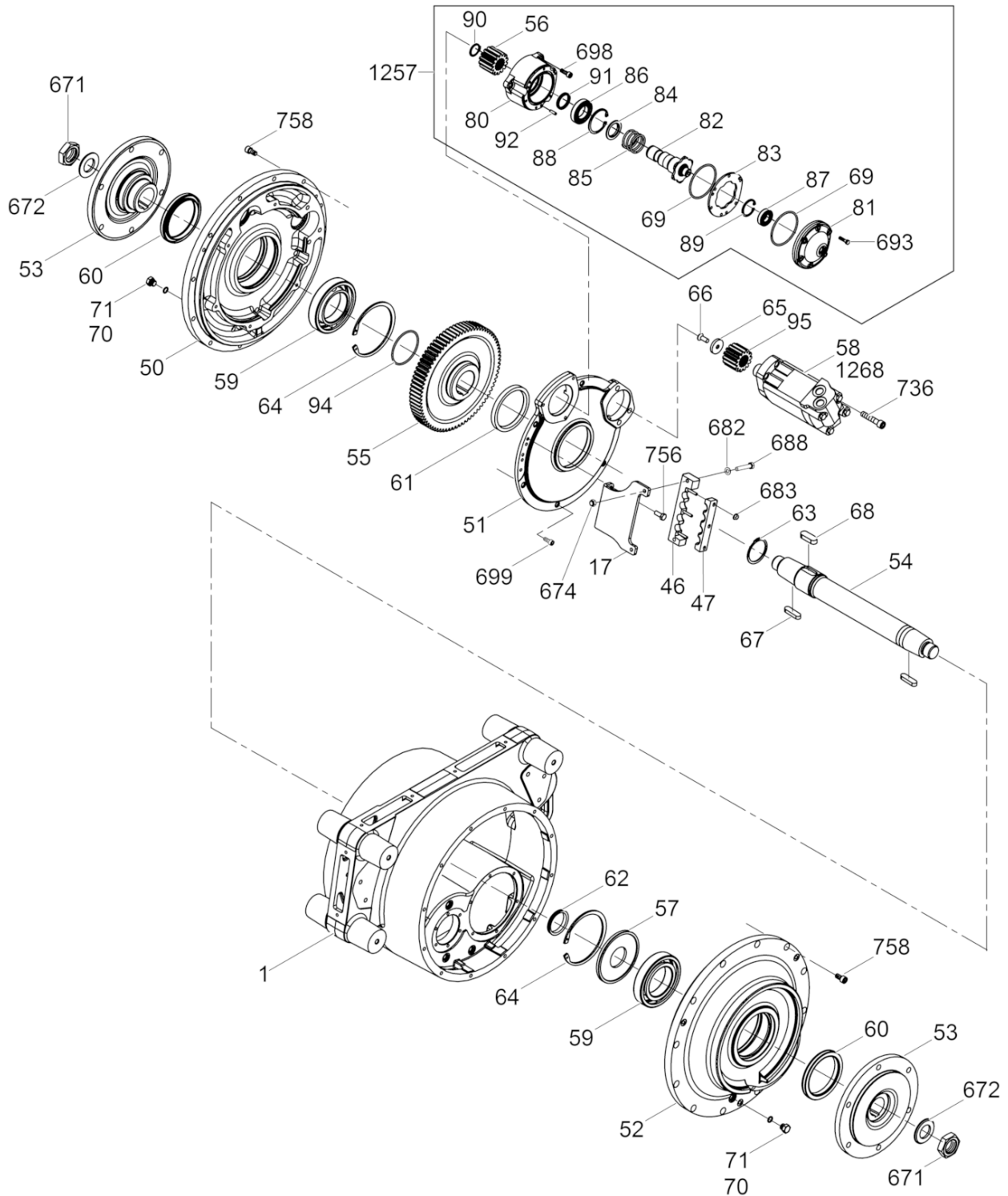

200_5200019255100012

Ref. Pos.	Part No. Artikel Nr.	Qty. St.	Description Beschreibung	Descripción Description	Measurem./Abm.	Norm
					Torque/Drehm.	Sealant Schmierstoff
1	5000116902	1	Drum support Bandagenträger	Soporte del tambor Support de tambour		
17	5200007278	1	Bracket Konsole	Soporte Support		
40	5200008651	1	Clamp Schelle	Abrazadera Agrafe		
41	5200008650	1	Clamp Schelle	Abrazadera Agrafe		
50	5000118366	1	Cover Deckel	Tapa Couvercle		
51	5000118368	1	Cover Deckel	Tapa Couvercle		
52	5000116903	1	Cover Deckel	Tapa Couvercle		
53	5000116906	2	Drum hub Bandagennabe	Maza de tambor Moyeu de tambour		
54	5000116907	1	Drive shaft Antriebswelle	Eje motor Arbre d'entraînement		
55	5000119284	1	Gear Zahnrad	Engranaje Engrenage		
56	5000116909	1	Pinion gear Ritzel	Piñon diferencial Pignon		
57	5000118796	1	Disc Scheibe	Disco Disque		
58	5000181899	1	Drive motor Antriebsmotor	Motor de accionamiento Moteur d'entraînement		
59	5000082961	2	Roller bearing Rollenlager	Rodamiento de rodillos Roulement à rouleaux		
60	5000119285	2	Seal Dichtung	Empaque Joint		
61	5000116874	1	Shaft seal Wellendichtring	Sello del eje Bague d'étanchéité	100 x 120 x 12	
62	5000119286	1	Shaft seal Wellendichtring	Sello del eje Bague d'étanchéité		
63	5000116869	1	Retaining ring Sicherungsring	Anillo de retención Bague d'arrêt	62 x 2	DIN471
64	5000044706	2	Retaining ring Sicherungsring	Anillo de retención Bague d'arrêt	140 x 4	DIN472
65	5000080666	1	Washer Scheibe	Arandela Rondelle		
66	5000080667	1	Screw Schraube	Tornillo Vis	3/8-16 x 1in	
67	5000116872	2	Square key Passfeder	Chaveta Clavette	A14 x 9 x 50	DIN6885
68	5000116873	1	Square key Passfeder	Chaveta Clavette	A18 x 11 x 50	DIN6885
69	5000119329	3	O-Ring O-Ring	Anillo-O Joint torique	85,32 x 3,53	
70	5000014398	2	O-Ring O-Ring	Anillo-O Joint torique	12 x 2	

Drum Drive w/Brake
Bandagenantrieb mit Bremse

RTKx-SC3

Accionamiento de Tambor con Freno
Entraînement de Tambour avec F

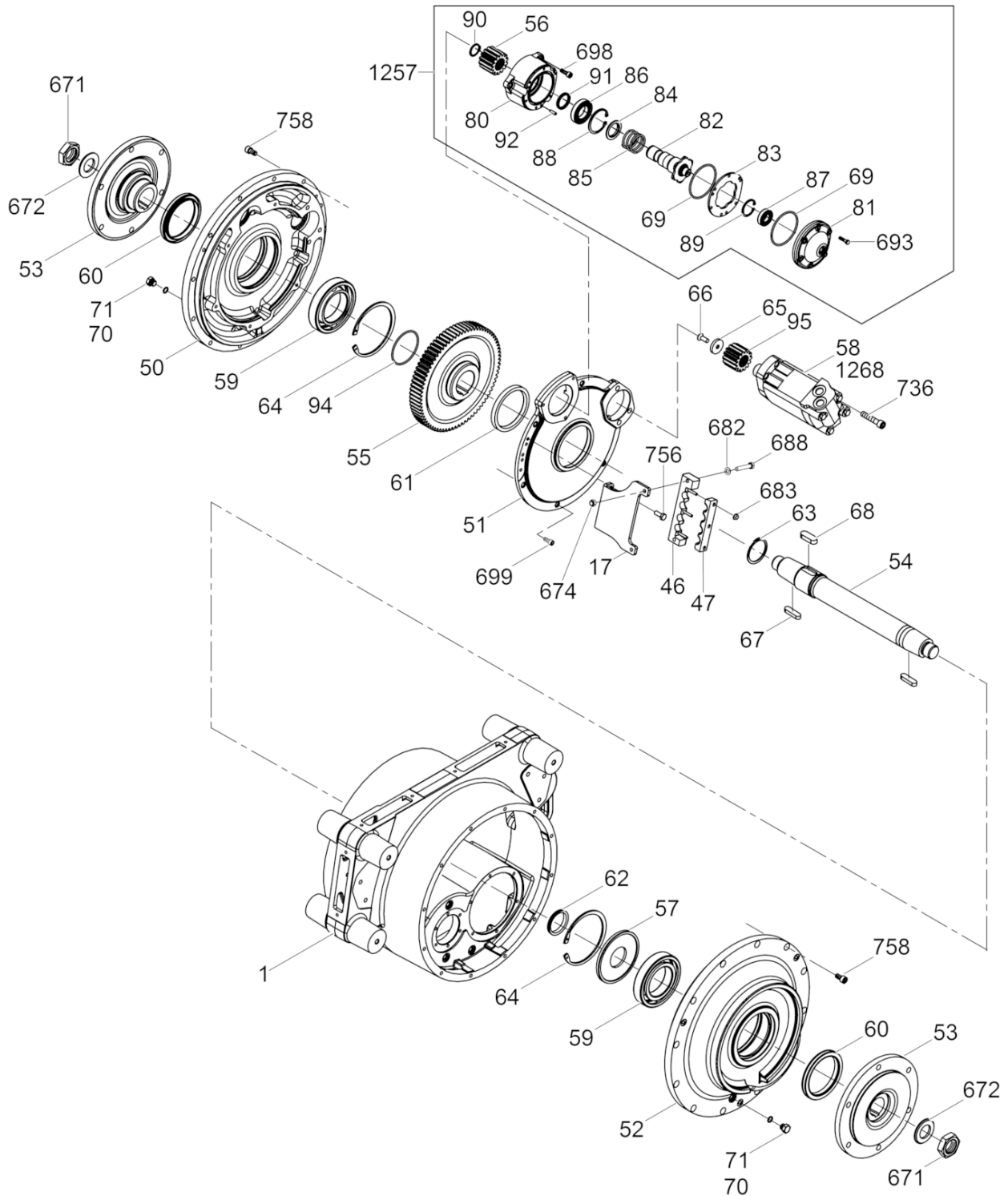

200_5200019255100012

Ref. Pos.	Part No. Artikel Nr.	Qty. St.	Description Beschreibung	Descripción Description	Measurement./Abm.	Norm
					Torque/Drehm.	Sealant Schmierstoff
71	5000078269	2	Plug (threaded) Schraubverschluss	Tapón roscado Bouchon	9/16-18in	
80	5000119377	1	Housing Gehäuse	Caja Carter		
81	5000117564	1	Cover Deckel	Tapa Couvercle		
82	5000154320	1	Shaft Welle	Eje Arbre		
83	5000117612	1	Plate Platte	Placa Plaque		
84	5000151152	1	Ring Ring	Anillo Anneau		
85	5000085783	1	Spring Feder	Resorte Ressort		
86	5000027402	1	Grooved ball bearing Rillenkugellager	Rodamiento de bolas Roulement à billes		
87	5002006236	1	Grooved ball bearing Rillenkugellager	Rodamiento de bolas Roulement à billes		
88	5002001042	1	Retaining ring Sicherungsring	Anillo de retención Bague d'arrêt	62 x 2	DIN472
89	5002004639	1	Retaining ring Sicherungsring	Anillo de retención Bague d'arrêt	42 x 1,75	DIN472
90	5000152277	1	Retaining ring Sicherungsring	Anillo de retención Bague d'arrêt	1,25 x 0,05	
91	5000089840	1	Shaft seal Wellendichtring	Sello del eje Bague d'étanchéité		
92	5000054245	3	Roll pin Spannstift	Pasador Goupille de tension	7/32 x 3/4 in	
93	5000119505	1	Plate Platte	Placa Plaque		
94	5000152276	1	O-Ring O-Ring	Anillo-O Joint torique	81,92 x 5,33	
95	5000154482	1	Pinion gear Ritzel	Piñon diferencial Pignon		
671	5000116871	2	Nut Mutter	Tuerca Écrou	M36 x 3 825Nm/609ft.lbs	S3
672	5000150020	2	Washer Scheibe	Arandela Rondelle	M36	
674	5000010367	2	Hexagon nut Sechskantmutter	Tuerca hexagonal Écrou hexagonal	M8	DIN985
682	5000010622	2	Flat washer Scheibe	Arandela Rondelle		
683	5000153379	3	Gasket Dichtung	Junta Joint		
688	5000117969	2	Hexagonal head cap screw Sechskantschraube	Tornillo hexagonal Boulon à tête hexagonale	M8 x 45 25Nm/18ft.lbs	
693	5000011469	6	Hexagonal head cap screw Sechskantschraube	Tornillo hexagonal Vis à tête hexagonale	M6 x 25 10Nm/7ft.lbs	DIN933 S4
698	5000011542	3	Cheese head screw Zylinderschraube	Tornillo cilíndrico Vis à tête cylindrique	41Nm/30ft.lbs	S3

Drum Drive w/Brake
Bandagenantrieb mit Bremse
Accionamiento de Tambor con Freno
Entraînement de Tambour avec F

RTKx-SC3

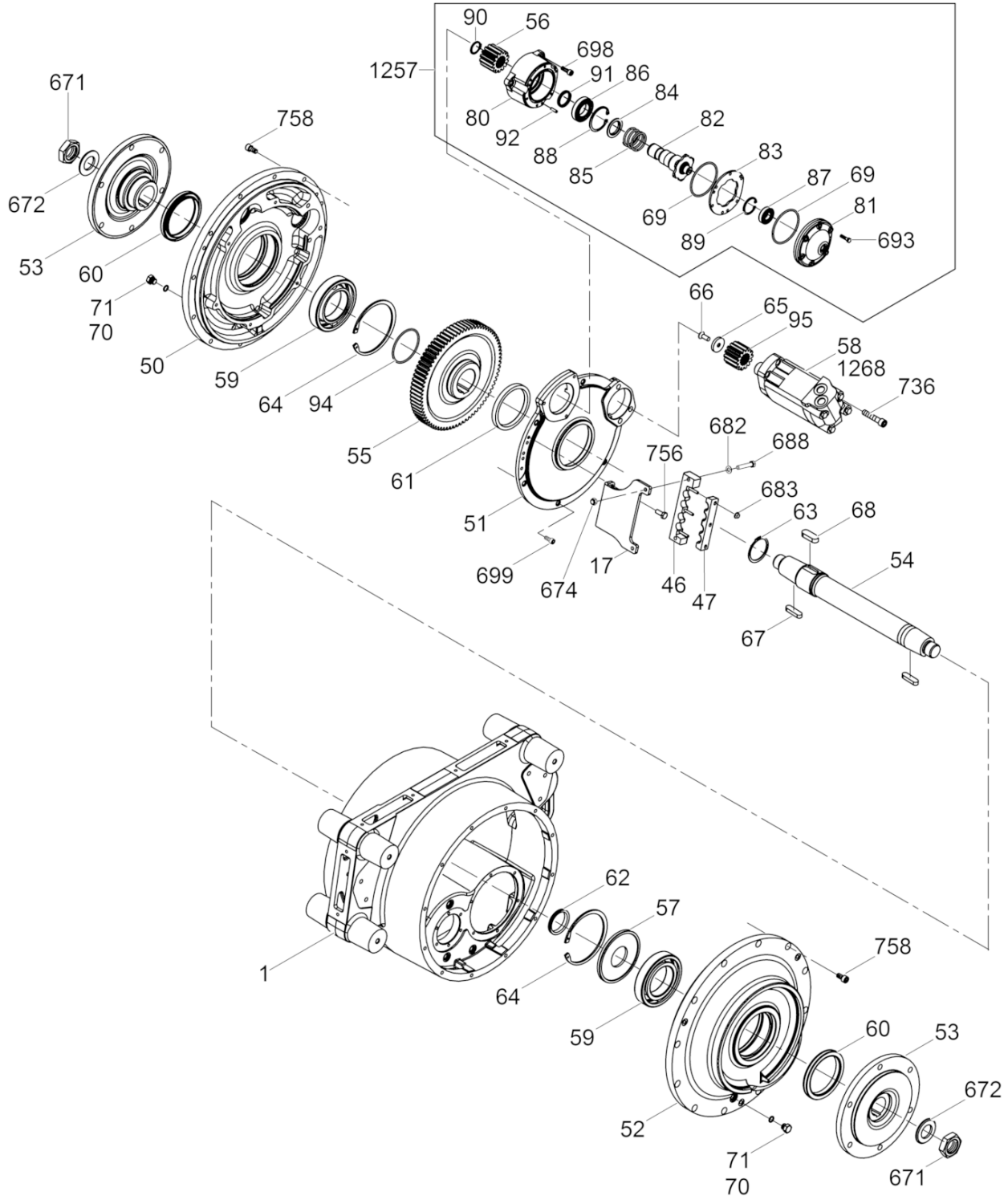

200_5200019255100012

Ref. Pos.	Part No. Artikel Nr.	Qty. St.	Description Beschreibung	Descripción Description	Measurement./Abm.	Norm
					Torque/Drehm.	Sealant Schmierstoff
699	5000011543	4	Socket head screw Zylinderschraube	Tornillo hueco Vis à six-pans creux	M8 x 20 25Nm/18ft.lbs	ISO4762
736	5000111979	3	Socket head cap screw Zylinderschraube	Tornillo cilíndrico Vis à tête cylindrique	M12 x 60 85Nm/63ft.lbs	ISO4762 S4
756	5000012362	2	Hexagonal head cap screw Sechskantschraube	Tornillo hexagonal Vis à tête hexagonale		
758	5000072758	30	Cheese head screw Zylinderschraube	Tornillo cilíndrico Vis à tête cylindrique	M10 x 20 49Nm/36ft.lbs	ISO4762 S3
1257	5000163621	1	Brake cpl. Bremse kpl.	Freno compl. Frein compl.		
1268	5000182756	1	Seal Kit Dichtungssatz	Juego-empaque Jeu-joint		
1689	5000011541	1	Cheese head screw Zylinderschraube	Tornillo cilíndrico Vis à tête cylindrique		

**Front Drum
Vorderbandage
Tambor Delantero
Tambour Avant**

RTKx-SC3

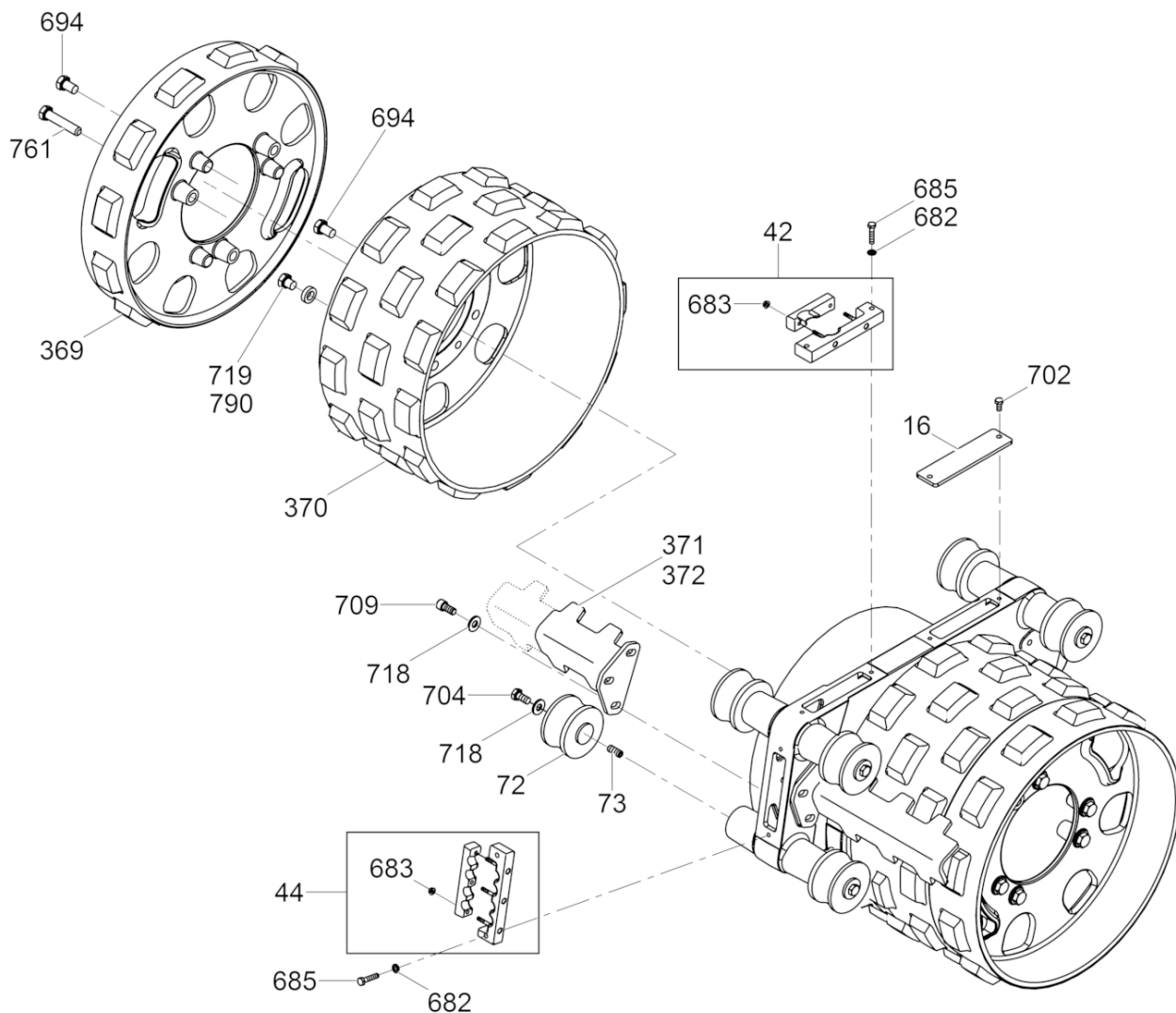

200_5200019257100013

Ref. Pos.	Part No. Artikel Nr.	Qty. St.	Description Beschreibung	Descripción Description	Measurement./Abm.	Norm
					Torque/Drehm.	Sealant Schmierstoff
16	5000150306	1	Plate Platte	Placa Plaque		
42	5200020383	1	Clamp Set Schellensatz	Juego de abrazaderas Jeu-agrafes		
44	5200020386	1	Clamp Set Schellensatz	Juego de abrazaderas Jeu-agrafes		
72	5002004814	6	Shockmount Gimetall-Kerblager mit Bund	Amortiguador Silentbloc	100 x 58	
73	5000180963	6	Setscrew Gewindestift	Tornillo Vis	M12 x 35	
369	5200003694	2	Drum extension Bandageverlängerung	Tambor de Extensión Extension de Tambour		
370	5200009074	2	Narrow drum Bandage-schmal	Tambor-angosto Tambour étroit		
371	5200007070	4	Wide Scraper Bar Kit Abstreifersatz (breit)	Juego de barra raspadora (anch) barre de curette (large)		
372	5200007072	4	Narrow scraper Bandage-schmal	Barra raspadora-angosto Racleur étroit		
682	5000010622	4	Flat washer Scheibe	Arandela Rondelle		
683	5000155519	5	Flange nut Flanschmutter	Tuerca de reborde Ecrou de bride	M6	DIN 1661
685	5000011341	4	Hexagonal head cap screw Sechskantschraube	Tornillo hexagonal Vis à tête hexagonale	M8 x 40 25Nm/18ft.lbs	DIN931 S3
694	5000011524	12	Hexagonal head cap screw Sechskantschraube	Tornillo hexagonal Vis à tête hexagonale	M16 x 25 210Nm/155ft.lbs	DIN933 S3
694	5000012382	12	Socket head cap screw Zylinderschraube	Tornillo cilíndrico Vis à tête cylindrique	M10 x 30 83Nm/61ft.lbs	
702	5000012361	2	Hexagonal head cap screw Sechskantschraube	Tornillo hexagonal Vis à tête hexagonale	M8 x 16 25Nm/18ft.lbs	DIN933 S3
704	5000013002	6	Hexagonal head cap screw Sechskantschraube	Tornillo hexagonal Vis à tête hexagonale	M12 x 25 86Nm/63ft.lbs	DIN933 S3
709	5000017087	12	Socket head cap screw Zylinderschraube	Tornillo cilíndrico Vis à tête cylindrique	M12 x 30 86Nm/63ft.lbs	ISO4762 S3
718	5000031565	18	Lockwasher Spannscheibe	Arandela elástica Rondelle de ressort	12	DIN6796
719	5000031826	6	Screw Schraube	Tornillo Vis	M16 x 16 210Nm/155ft.lbs	S3
761	5000011380	6	Hexagonal head cap screw Sechskantschraube	Tornillo hexagonal Boulon à tête hexagonale	M16 x 80 210Nm/155ft.lbs	DIN 931
790	5200009076	6	Washer Scheibe	Arandela Rondelle	M16	

Rear Drum
Hinterbandage
Tambor de Atrás
Tambour Arrière

RTKx-SC3

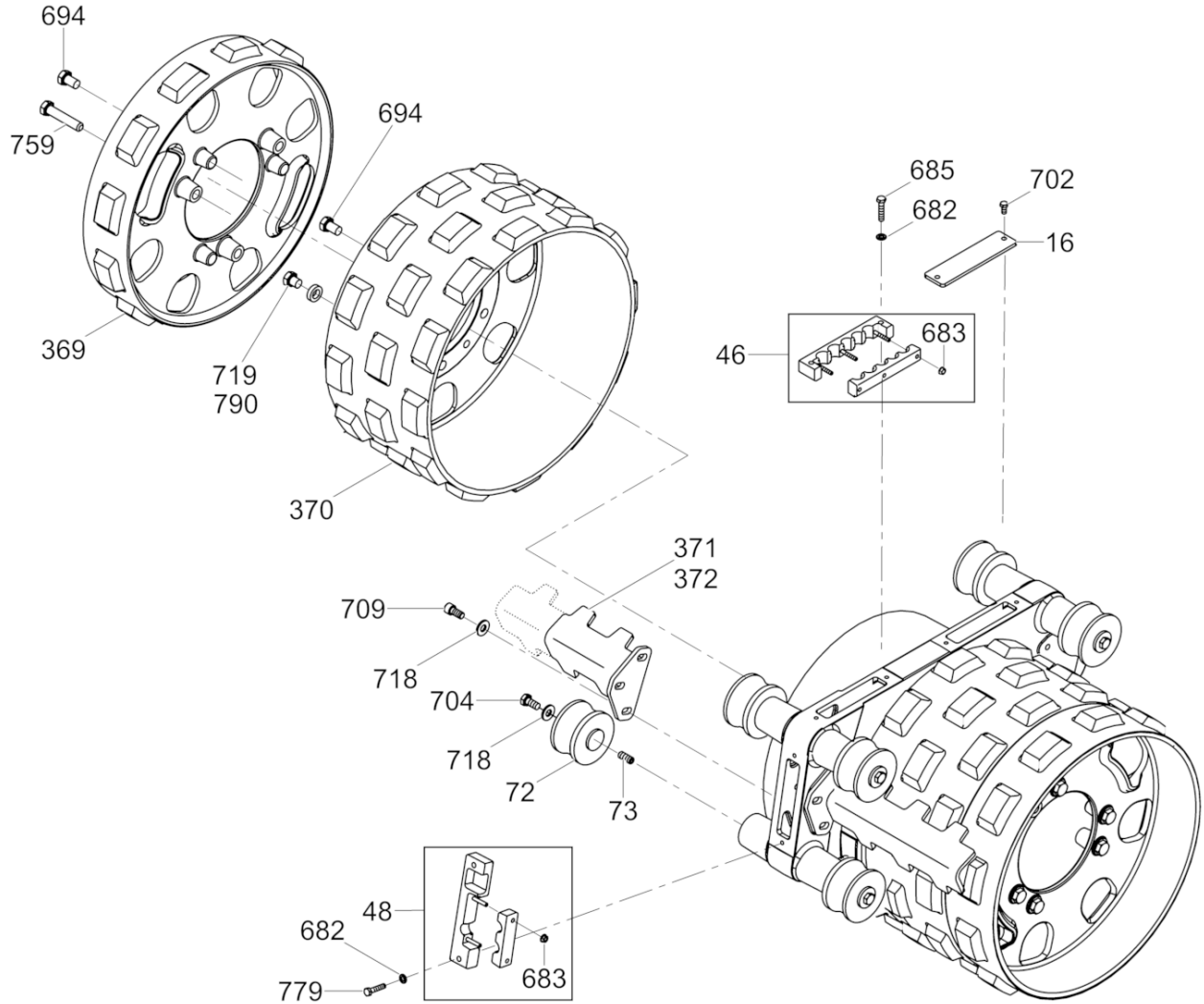

200_5200019257120014

Ref. Pos.	Part No. Artikel Nr.	Qty. St.	Description Beschreibung	Descripción Description	Measurement./Abm.	Norm
					Torque/Drehm.	Sealant Schmierstoff
16	5000150306	1	Plate Platte	Placa Plaque		
46	5200020388	1	Clamp Set Schellensatz	Juego de abrazaderas Jeu-agrafes		
48	5100036426	1	Clamp Set Schellensatz	Juego de abrazaderas Jeu-agrafes		
72	5002004814	6	Shockmount Gimmetall-Kerblager mit Bund	Amortiguador Silentbloc	100 x 58	
73	5000180963	6	Setscrew Gewindestift	Tornillo Vis	M12 x 35	
369	5200003694	2	Drum extension Bandageverlängerung	Tambor de Extensión Extension de Tambour		
370	5200009074	2	Narrow drum Bandage-schmal	Tambor-angosto Tambour étroit		
371	5200007070	4	Wide Scraper Bar Kit Abstreifersatz (breit)	Juego de barra raspadora (anch) barre de curette (large)		
372	5200007072	4	Narrow scraper Bandage-schmal	Barra raspadora-angosto Racleur étroit		
678	5000010624	2	Flat washer Scheibe	Arandela Rondelle		
682	5000010622	5	Flat washer Scheibe	Arandela Rondelle		
683	5000155519	5	Flange nut Flanscmutter	Tuerca de reborde Ecrou de bride	M6	DIN 1661
685	5000011341	4	Hexagonal head cap screw Sechskantschraube	Tornillo hexagonal Vis à tête hexagonale	M8 x 40 25Nm/18ft.lbs	DIN931 S3
694	5000011524	12	Hexagonal head cap screw Sechskantschraube	Tornillo hexagonal Vis à tête hexagonale	M16 x 25 210Nm/155ft.lbs	DIN933 S3
702	5000012361	2	Hexagonal head cap screw Sechskantschraube	Tornillo hexagonal Vis à tête hexagonale	M8 x 16 25Nm/18ft.lbs	DIN933 S3
704	5000013002	6	Hexagonal head cap screw Sechskantschraube	Tornillo hexagonal Vis à tête hexagonale	M12 x 25 86Nm/63ft.lbs	DIN933 S3
709	5000017087	12	Socket head cap screw Zylinderschraube	Tornillo cilíndrico Vis à tête cylindrique	M12 x 30 86Nm/63ft.lbs	ISO4762 S3
718	5000031565	18	Lockwasher Spannscheibe	Arandela elástica Rondelle de ressort	12	DIN6796
719	5000031826	6	Screw Schraube	Tornillo Vis	M16 x 16 210Nm/155ft.lbs	S3
759	5000011380	6	Hexagonal head cap screw Sechskantschraube	Tornillo hexagonal Boulon à tête hexagonale	M16 x 80 210Nm/155ft.lbs	DIN 931
779	5000011456	2	Hexagonal head cap screw Sechskantschraube	Tornillo hexagonal Vis à tête hexagonale		
790	5200009076	6	Washer Scheibe	Arandela Rondelle	M16	

Exciter cpl.
Erreger kpl.
Excitador compl.
Excitatrice compl.

RTKx-SC3

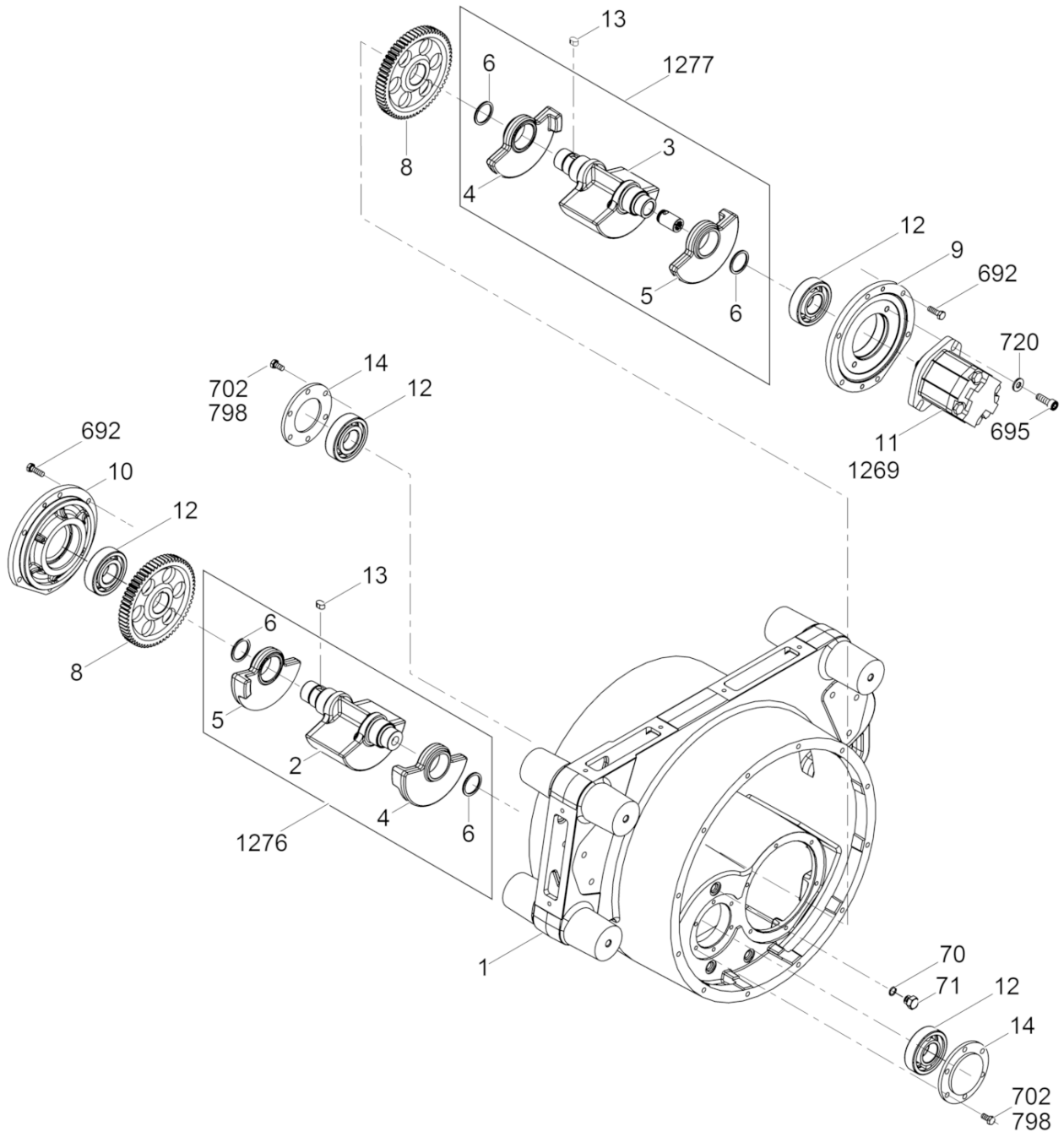

200_5200019255100015

Ref. Pos.	Part No. Artikel Nr.	Qty. St.	Description Beschreibung	Descripción Description	Measurement./Abm.	Norm
					Torque/Drehm.	Sealant Schmierstoff
1	5000116902	1	Drum support Bandagenträger	Soporte del tambor Support de tambour		
2	5000171032	2	Exciter shaft w/o counterbore Erregerwelle ohne Senkung	Eje del excitador s/escariador Arbre de l'excitatrice sans lo		
3	5000171033	2	Exciter shaft w/counterbore Erregerwelle mit Senkung	Eje del excitador c/escariador Arbre de l'excitatrice avec lo		
4	5000171034	4	Eccentric weight Unwucht	Masa excéntrica Balourd excentrique		
5	5000171035	4	Eccentric weight Unwucht	Masa excéntrica Balourd excentrique		
6	5000171028	8	Retaining ring Sicherungsring	Anillo de retención Bague d'arrêt	45 x 1,69in	
8	5200001515	2	Gear Zahnrad	Engranaje Engrenage		
9	5000116958	1	Cover Deckel	Tapa Couvercle		
10	5000116959	1	Bearing cover Lagerdeckel	Tapa del rodamiento Tapa del rodamiento		
11	5000182917	1	Exciter motor Erregermotor	Motor excitador Moteur d'excitatrice		
12	5000080742	4	Roller bearing Rollenlager	Rodamiento de rodillos Roulement à rouleaux		
13	5000115699	2	Square key Passfeder	Chaveta Clavette	A10 x 8 x 16	DIN6885
14	5000171000	4	Cover Deckel	Tapa Couvercle		
70	5000014398	3	O-Ring O-Ring	Anillo-O Joint torique	12 x 2	
71	5000078269	3	Plug (threaded) Schraubverschluss	Tapón roscado Bouchon	9/16-18in	
692	5000011457	12	Hexagonal head cap screw Sechskantschraube	Tornillo hexagonal Vis à tête hexagonale	M8 x 25 25Nm/18ft.lbs	DIN933 S3
695	5000011534	2	Cheese head screw Zylinderschraube	Tornillo cilíndrico Vis à tête cylindrique	M10 x 30 49Nm/36ft.lbs	ISO4762
702	5000012361	12	Hexagonal head cap screw Sechskantschraube	Tornillo hexagonal Vis à tête hexagonale	M8 x 16 25Nm/18ft.lbs	DIN933 S3
720	5000033988	2	Lockwasher Spannscheibe	Arandela elástica Rondelle de ressort	10	DIN6796
798	5000172326	24	Flat washer Scheibe	Arandela elástica Rondelle de ressort	8.4	
1269	5200024514	1	Seal Kit Dichtungssatz	Juego-empaque Jeu-joint		
1276	5000171445	2	Exciter Shaft Kit w/o counterbore Erregerwellensatz ohne Senkung	Juego-eje del excitador s/escariador Jeu-arbre de l'excitatrice san		
1277	5000171446	2	Exciter Shaft Kit w/counterbore Erregerwellensatz mit Senkung	Juego-eje del excitador c/escariador Jeu-arbre de l'excitatrice ave		

Hydraulic Manifold
Hydraulikverteiler
Distribuidor Hidráulico
Tubulure Hydraulique

RTKx-SC3

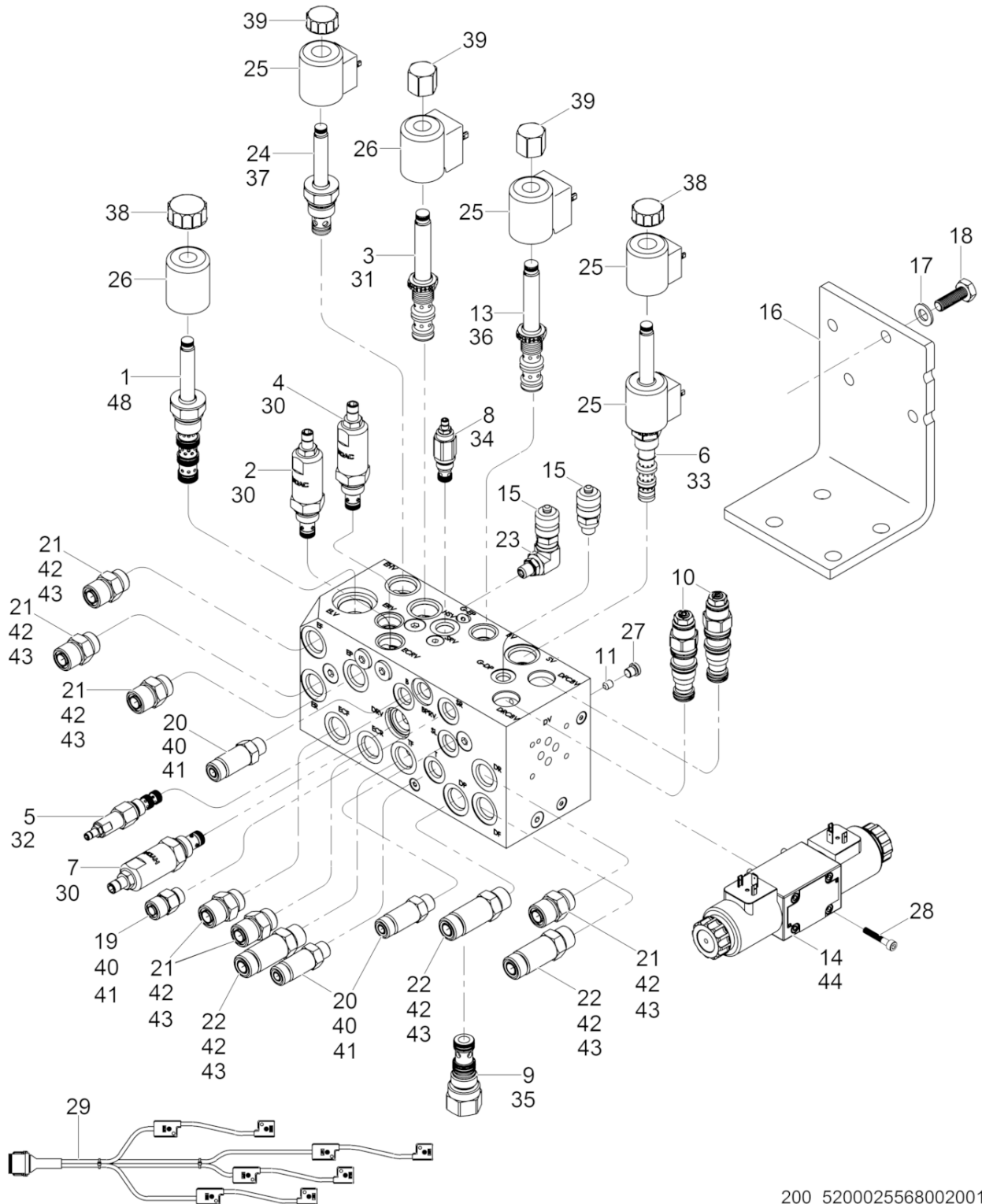

200_5200025568002001

Ref. Pos.	Part No. Artikel Nr.	Qty. St.	Description Beschreibung	Descripción Description	Measurem./Abm.	Norm
					Torque/Drehm.	Sealant Schmierstoff
1	5100016775	1	Solenoid valve Ventil-Solenoid	Válvula-solenoide Electrovanne		
2	5100016776	1	Relief valve Überdruckventil	Válvula de desahoga Soupape de surpression		
3	5100016777	1	Solenoid valve Ventil-Solenoid	Válvula-solenoide Electrovanne		
4	5100016778	1	Relief valve Überdruckventil	Válvula de desahoga Soupape de surpression		
5	5100016779	1	Brake valve Bremsventil	Válvula de frenaje Robinet de freinage		
6	5100016780	1	Steering valve Steuerventil	Válvula de dirección Soupape de direction		
7	5100016781	1	Relief valve Überdruckventil	Válvula de desahoga Soupape de surpression		
8	5100016782	1	Steering valve Steuerventil	Válvula de dirección Soupape de direction		
9	5100016783	1	Bypass valve Bypassventil	Válvula de desviador Soupape de dérivation		
10	5100016784	2	Counterbalance valve Ausgleichsventil	Válvula de compensación Soupape de contrecharge		
11	5100016785	1	Setscrew Gewindestift	Tornillo Vis	2,70	
12	5100016786	1	Setscrew Gewindestift	Tornillo Vis	0,80	
13	5100016787	1	Brake valve Bremsventil	Válvula de frenaje Robinet de freinage		
14	5100016788	1	Drive valve Antriebsventil	Válvula de mando Soupape d'entraînement		
15	5000182738	2	Test fitting w/cap Prüfverschraubung mit Kappe	Unión de prueba con tapa Raccord d'essai avec couvercle	M16 x 2, 7/16-20 UNC	
16	5100016789	1	Mounting bracket Konsole	Ménsula Support		
17	5000010621	3	Washer Scheibe	Arandela Rondelle		
18	5200015174	4	Screw Schraube	Tornillo Vis		
19	5000078816	1	Adapter fitting Zwischenverschraubung	Unión con adaptador Raccord intermédiaire		
20	5000158574	3	Fitting Verschraubung	Unión Raccord	No.6	
21	5000080558	6	Fitting Verschraubung	Unión Raccord		
22	5000158572	3	Fitting Verschraubung	Unión Raccord	No.8	
23	5100016790	1	Hydraulic fitting Hydraulikverschraubung	Unión hidráulico Raccord hydraulique	4 x 4	
24	5100016791	1	Exciter valve Erregung des Ventils	Excitador de válvula Excitation de valve		
25	5100016792	4	Coil Spule	Bobina Bobine	12V	

Hydraulic Manifold
Hydraulikverteiler
Distribuidor Hidráulico
Tubulure Hydraulique

RTKx-SC3

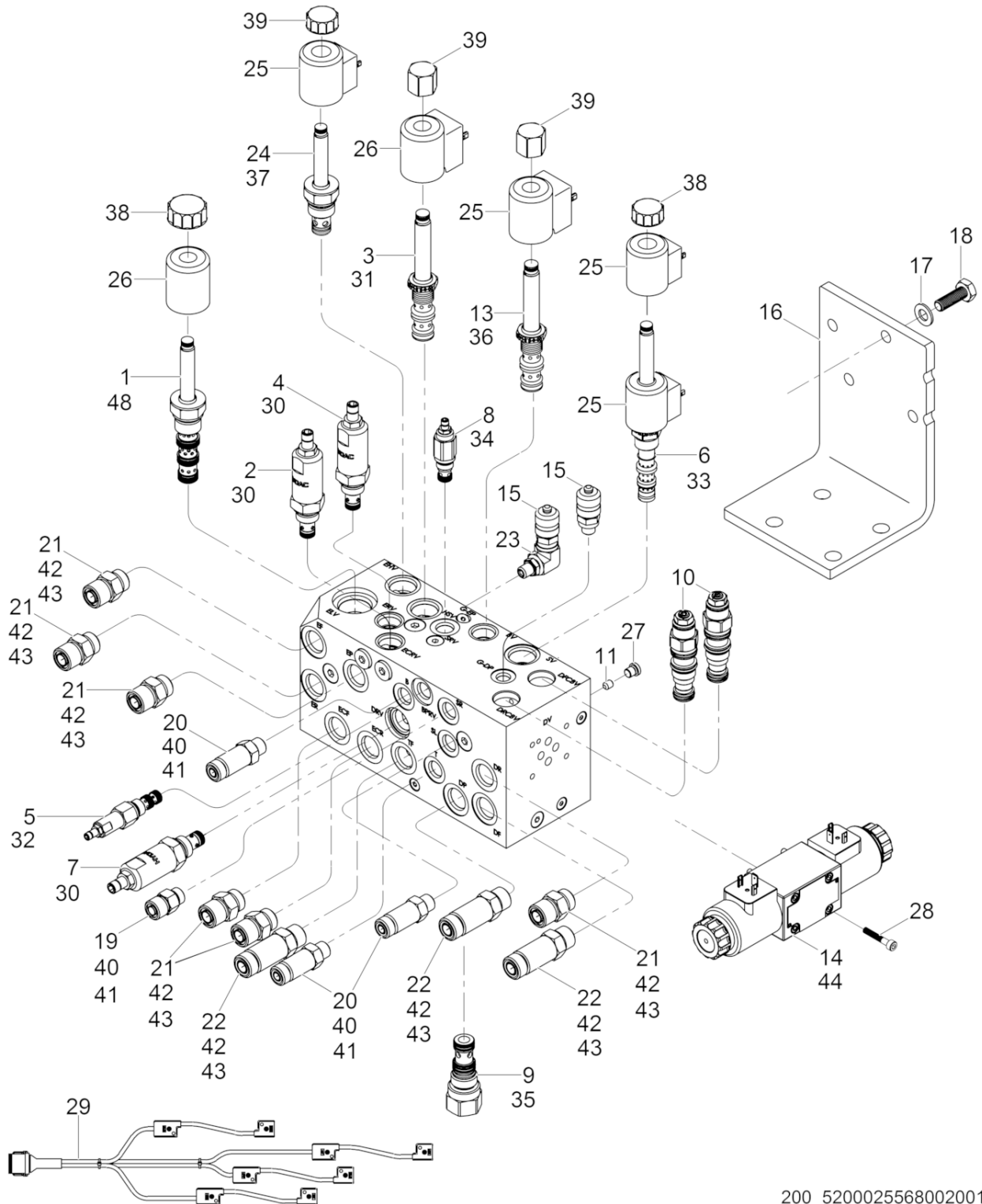

200_5200025568002001

Ref. Pos.	Part No. Artikel Nr.	Qty. St.	Description Beschreibung	Descripción Description	Measurement./Abm.	Norm
					Torque/Drehm.	Sealant Schmierstoff
26	5100016793	2	Coil Spule	Bobina Bobine	12V	
27	5100016794	9	Plug Stopfen	Tapón Bouchon	No. 2	
28	5000011558	4	Cheese head screw Zylinderschraube	Tornillo cilíndrico Vis à tête cylindrique	M5 x 30 10Nm/7ft.lbs	ISO4762
29	5200023703	1	Wiring harness Kabelbaum	Conjunto de cables Harnais de câbles électriques		
30	5100016796	3	Seal Kit Dichtungssatz	Juego-empaque Jeu-joint		
31	5100016797	1	Seal Kit Dichtungssatz	Juego-empaque Jeu-joint		
32	5100016798	1	Seal Kit Dichtungssatz	Juego-empaque Jeu-joint		
33	5100016799	1	Seal Kit Dichtungssatz	Juego-empaque Jeu-joint		
34	5100016800	1	Seal Kit Dichtungssatz	Juego-empaque Jeu-joint		
35	5100016801	1	Seal Kit Dichtungssatz	Juego-empaque Jeu-joint		
36	5100016802	1	Seal Kit Dichtungssatz	Juego-empaque Jeu-joint		
37	5100016803	1	Seal Kit Dichtungssatz	Juego-empaque Jeu-joint		
38	5100016804	2	Coil Kit Spule kpl.	Bobina compl. Bobine compl.		
39	5100016805	3	Coil Kit Ventilkappe	Bobina compl. Bobine compl.		
40	5000080731	4	O-Ring O-Ring	Anillo-O Joint torique	0,468 x 0,078in	
41	5000080736	4	O-Ring O-Ring	Anillo-O Joint torique	0,364 x 0,070in	
42	5000080732	9	O-Ring O-Ring	Anillo-O Joint torique	0,644 x 0,087in	
43	5000080737	9	O-Ring O-Ring	Anillo-O Joint torique	0,489 x 0,070in	
44	5100016873	1	Seal Kit Dichtungssatz	Juego-empaque Jeu-joint		
48	5100016795	1	Seal Kit Dichtungssatz	Juego-empaque Jeu-joint		

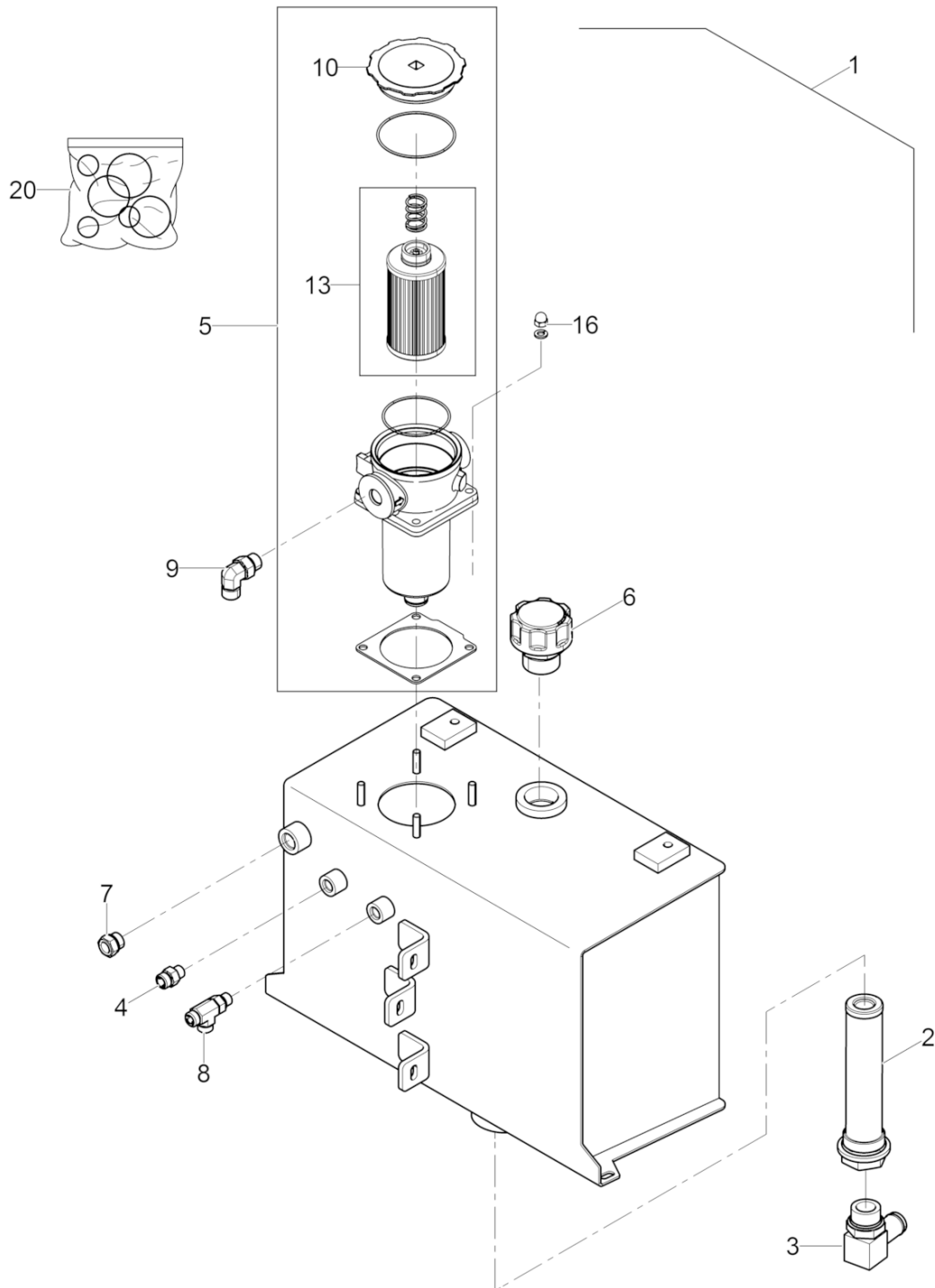

200_5200000844001001

Ref. Pos.	Part No. Artikel Nr.	Qty. St.	Description Beschreibung	Descripción Description	Measurement/Abm.	Norm
					Torque/Drehm.	Sealant Schmierstoff
1	5200000844	1	Hydraulic tank Hydrauliktank	Tanque hidráulico Réservoir hydraulique		
2	5000182746	1	Suction strainer Saugkorb	Colador Crépine		
3	5000182747	1	Barbed fitting Verschraubung mit Widerhaken	Unión dentada Raccord à picot	No.6 x 90	
4	5000078816	1	Adapter fitting Zwischenverschraubung	Unión con adaptador Raccord intermédiaire		
5	5000182748	1	Return filter RückleitungsfILTER	Filtro de retorno Filtre de retour		
6	5200000845	1	Breather tube Entlüftungskappe	Tapa respiradero Capuchon reniflard		
7	5000116236	1	Sightglass Ölschauglas	Mirilla del nivel de aceite Verre-regard d'huile		
8	5000083412	1	Fitting Verschraubung	Unión Raccord		
9	5000111272	1	Hydraulic elbow fitting Hydraulikrohrkrümmer	Codo hidráulico Coude hydraulique	SAE No.8 x 90	
10	5000182750	1	Cover Deckel	Tapa Couvercle		
13	5000182752	1	Filter element Filterelement	Elemento del filtro Élément du filtre		
16	5000159508	4	Acorn nut Hutmutter	Tuerca Ecrou	M10	
20	5000182733	1	Gasket & O-Ring Set Dichtungs- u. O-Ringsatz	Juego de juntas/anillos-O Jeu de joints		

**Transmitter Module
Sender
Transmisor
Transmetteur**

RTKx-SC3

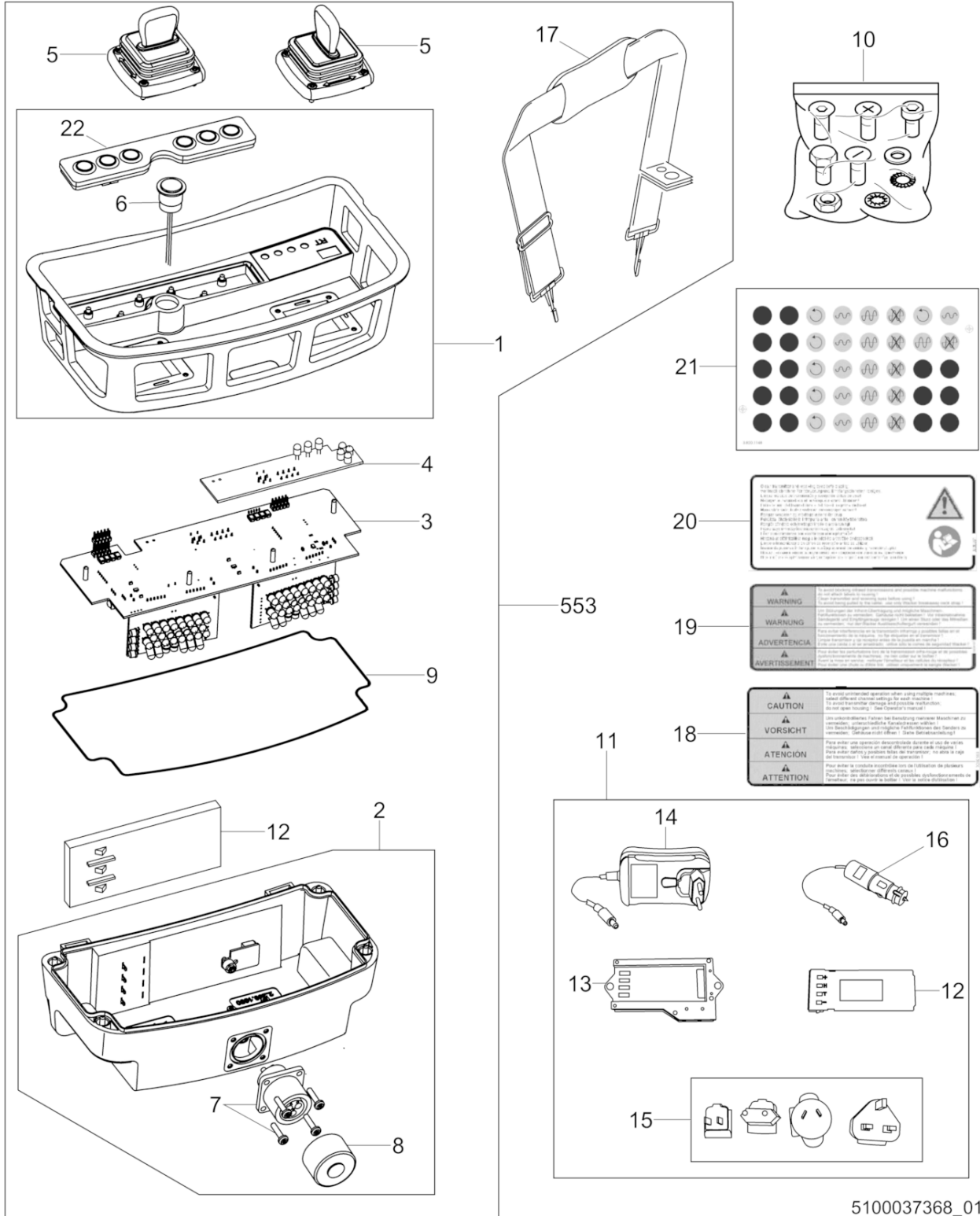

5100037368_01

Ref. Pos.	Part No. Artikel Nr.	Qty. St.	Description Beschreibung	Descripción Description	Measurem./Abm.	Norm
					Torque/Drehm.	Sealant Schmierstoff
1	5100029414	1	Upper housing Oberer Rahmen	Chasis superior Châssis supérieur		
2	5000180315	1	Lower housing Untere Umhüllung	Envoltura inferior Gaine inférieure		
3	5000180316	1	Circuit board Schaltplatte	Tablero de circuitos Carte de circuit		
4	5000180317	1	Circuit board display Schaltplattenausstellung	Presentación de tablero de circuitos Affichage de carte de circuit		
5	5000177083	2	Steering Lever Kit Steuerhebel-Satz	Palanca de Dirección-Juego Lever de Direction-Jeu		
6	5100026184	1	Switch Kit Satz-Schalter	Juego-interruptor Jeu-interrupteur		
7	5100037365	1	3-Pin Connector 3-polige Buchse	Socket 3-pin 3 broches		
8	5000117184	1	Cap Kappe	Tapa Couvercle		
9	5000164704	1	Seal Dichtung	Empaque Joint		
10	5000180320	1	Hardware Kit Kleinteilesatz	Juego de piezas pequeñas Jeu de pièces		
11	5000213091	1	Charging Set Ladegerät	Juego de carga Jeu de charge		
12	5000210156	1	Battery Akku	Batería Accumulateur		
13	5000209760	1	Battery charger Ladegerät	Cargador par batería Chargeur de batteries		
14	5000209761	1	Electrical plug Steckernetzteil	Enchufe de alimentación Mains plug		
15	5000209762	1	Plug Adapter Set Steckeradapter-Set	Enchufe de alimentación Mains plug		
16	5000209763	1	Power cable Anschlusskabel	Cable de alimentación Cable d'alimentation		
17	5000114783	1	Band Band	Cinta Ruban		
18	5000209158	1	Instruction Label Aufkleber-Hinweis	Calcomanía-Indicación Autocollant avec Indication		
19	5000209157	1	Label-warning Aufkleber-Warnung	Calcomanía-Advertencia Autocollant-Avertissement		
20	5000226261	1	Label Aufkleber	Calcomanía Autocollant		
21	5200017125	1	Label sheet Aufkleberblatt	Hoja de calcomanías Feuille d'autocollants		
22	5100037750	1	Switch plate module Plattenmodul anschließen	Módulo de placa de interruptor Module de plaque d'interrupteur		
553	5000165514	1	Transmitter module Sender	Transmisor Transmetteur		

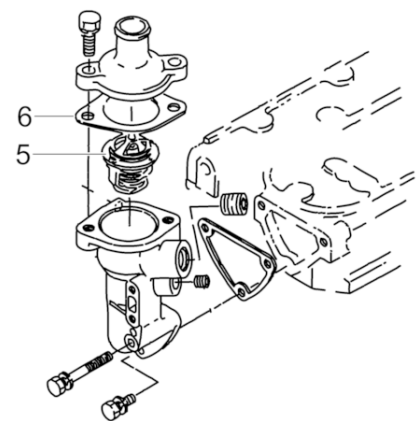
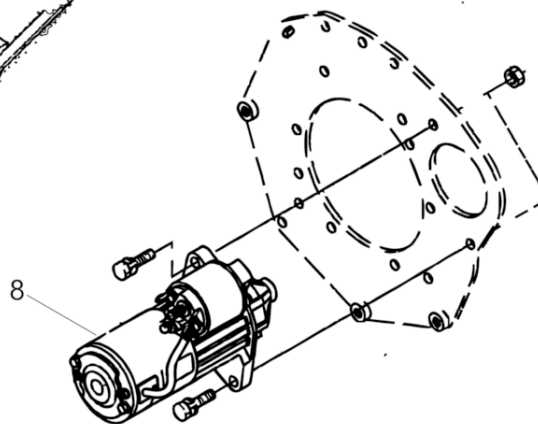
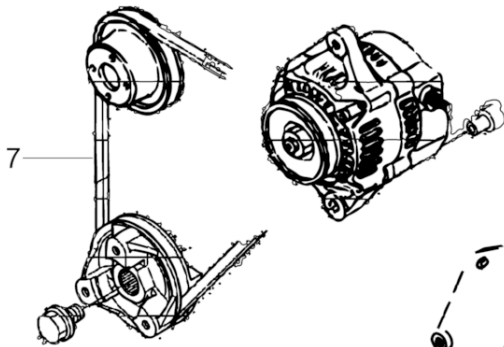
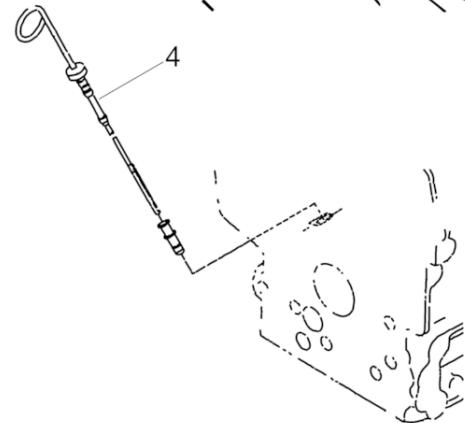
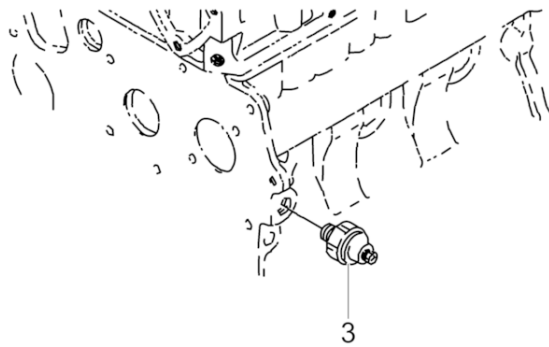
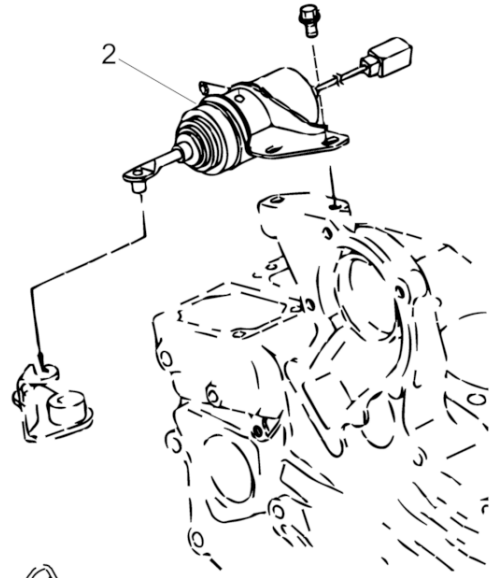
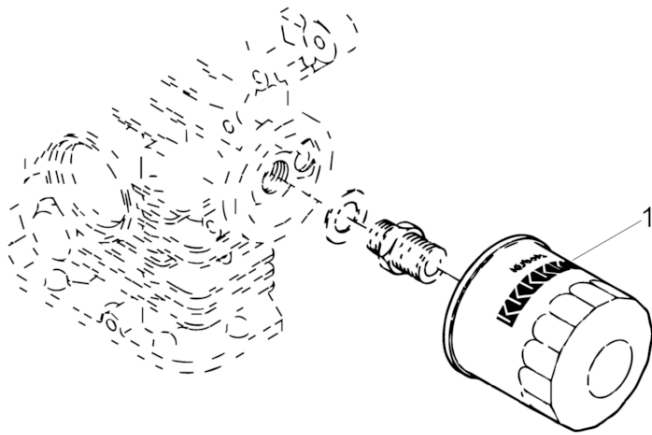

200_5200017279001001

Ref. Pos.	Part No. Artikel Nr.	Qty. St.	Description Beschreibung	Descripción Description	Measurement./Abm.	Norm
					Torque/Drehm.	Sealant Schmierstoff
1	5200004741	1	Oil filter Ölfilter	Filtro de aceite Filtre d'huile		
2	5100022591	1	Stop Solenoid Abstellmagnet	Dejar de solenoide Arrêter solénoïde		
3	5200024858	1	Oil pressure switch Öldruckschalter	Interruptor de presión de aceite Interrupteur à pression d'huile		
4	5200023778	1	Dipstick Peilstab	Indicador del nivel de aceite Réglette-jauge		
5	5000176754	1	Thermostat Temperaturregler	Termóstato Thermostat		
6	5000176755	1	Thermostat gasket Temperaturreglerdichtung	Junta del termóstato Joint du thermostat		
7	5200004743	1	Belt Zahnriemen	Correa Courroie		
8	5100027959	1	Starter cpl. Starter kpl.	Arrancador compl. Démarreur compl.		

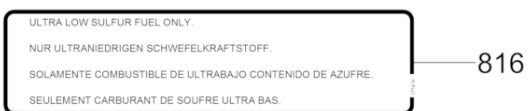
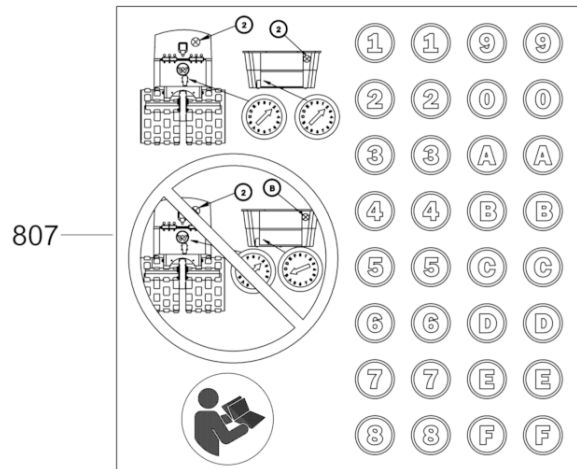
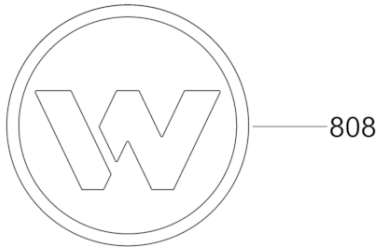
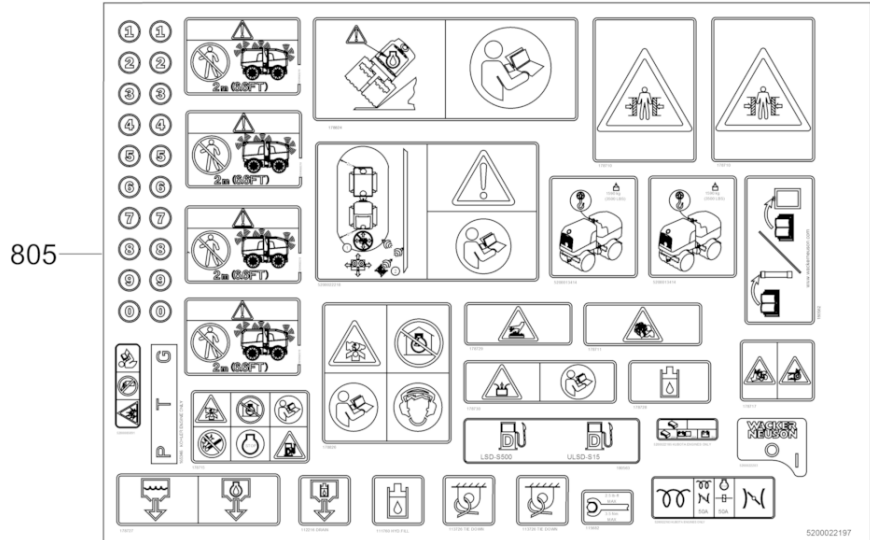

801 RTSC3

802 WACKER
NEUSON

5100042915_01

Ref. Pos.	Part No. Artikel Nr.	Qty. St.	Description Beschreibung	Descripción Description	Measurement./Abm.	Norm
					Torque/Drehm.	Sealant Schmierstoff
801	5100041611	2	Labels Aufkleber	Calcomanias Autocollants		
802	5000222136	2	Label-logo Aufkleber, Logo	Calcomanía-logotipo Autocollant - logo	100 OD	
805	5200022197	1	Label sheet-EU Aufkleberblatt-EU	Hoja de calcomanias-EU Feuille d'autocollants-EU		
807	5000181067	1	Label Aufkleber	Calcomania Autocollant		
808	5000222087	2	Label Symbol Aufkleber Symbol	Calcomania Símbolo Autocollant Símbolo	120 OD	
810	5000153799	1	Label Aufkleber	Calcomania Autocollant		



**WACKER
NEUSON**

**Accessories
Sonderzubehör
Accesorios
Accessoires**

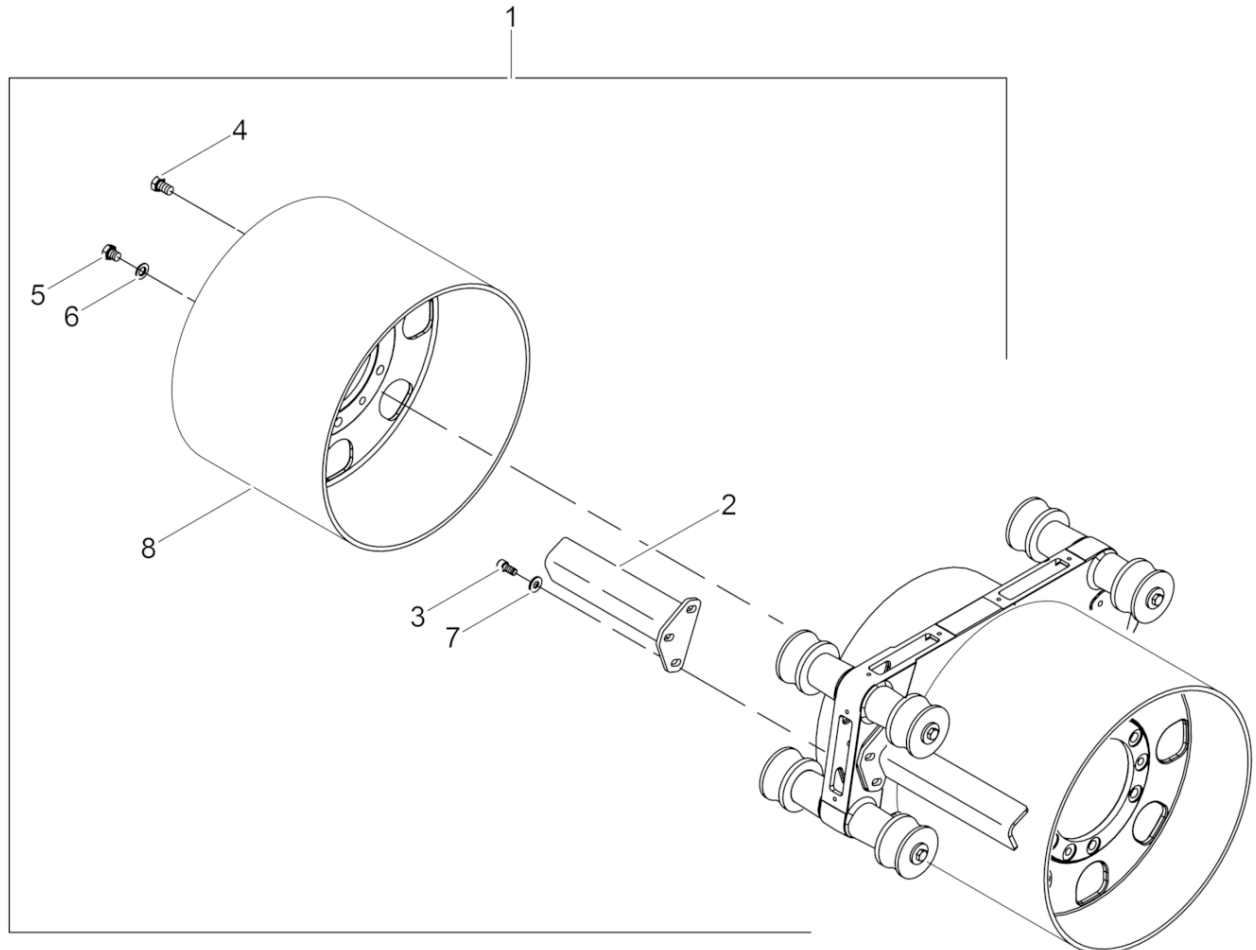

wc_ex0162787001

Ref. Pos.	Part No. Artikel Nr.	Qty. St.	Description Beschreibung	Descripción Description	Measurement/Abm.	Norm
					Torque/Drehm.	Sealant Schmierstoff
1	5000162787	1	Smooth drum kit Bandagensatz	Juego de tambor (plano) Jeu de tambour (lisse)	1000mm/40in	
2	5200006892	8	Wide scraper Bandage-Abstreifer	Barra raspadora-ancho Racleur large		
3	5000017087	24	Socket head cap screw Zylinderschraube	Tornillo cilíndrico Vis à tête cylindrique	M12 x 30 86Nm/63ft.lbs	ISO4762 S3
4	5000011542	24	Cheese head screw Zylinderschraube	Tornillo cilíndrico Vis à tête cylindrique	202Nm/149ft.lbs	S3
5	5000031826	12	Screw Schraube	Tornillo Vis	M16 x 16 202Nm/149ft.lbs	S3
6	5000010618	24	Flat washer Scheibe	Arandela Rondelle	16	ISO7090
7	5000031565	24	Lockwasher Spannscheibe	Arandela elástica Rondelle de ressort	12	DIN6796
8	5000171665	4	Smooth drum Bandage (glatt)	Tambor (plano) Tambour (lisse)	820	



**WACKER
NEUSON**