



**WACKER
NEUSON**

Ersatzteilkatalog
Spare parts list
Catalogo de piezas de repuesto
Catalogue des pièces détachées

**Walze
Roller
Rodillos
Rouleaux**

RD7YE



Type	RD7YE
Material Number	5100038032
Version	106
Language	de en es fr



www.wackerneuson.com

Copyright © 04.2019
Wacker Neuson Production Americas LLC
Printed in USA.
All rights reserved.

Ein Typenschild mit Typ, Artikelnummer, Version und Maschinen-Nummer ist an jedem Gerät angebracht. Die Daten von diesem Schild bitte notieren, damit sie auch bei Verlust oder Beschädigung des Schildes noch vorhanden sind. Der Typ, die Artikelnummer, die Versions-Nummer und die Maschinen-Nummer sind bei der Ersatzteilbestellung oder Nachfragen bezüglich Service-Informationen stets erforderlich.

Bei den in den Ersatzteillisten fettgedruckten Nummern handelt es sich um empfohlene Ersatzteile. Dies bedeutet, daß diese Teile bei normalen Anwendungsbedingungen natürlicher Abnutzung ausgesetzt sind und gelegentlich ersetzt oder überarbeitet werden müssen. Es wird geraten, diese Teile auf Lager bereit zu haben, um für Service-Arbeiten an diesem Gerät vorbereitet zu sein. Lagerbestände für diese und andere Teile, welche für ausgiebigere Reparaturarbeiten benötigt werden, können je nach Service-Gewohnheiten der einzelnen Kunden variieren.

Die Nummern meines Gerätes sind:

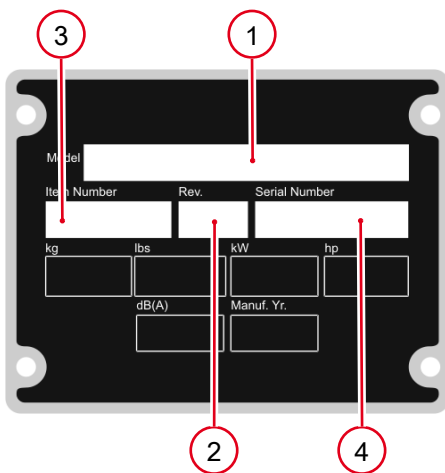

1. Typ
2. Version
3. Artikel-Nr.
4. Maschinen-Nr.

Umrechnungstabelle

Volumeneinheit	
1 ml	0.034 US fl.oz.
1 l	0.260 gal
Längeneinheit	
1 mm	0.039 in
1 m	3.280 ft
Gewicht	
1 kg	2.200 lbs
1 g	0.035 oz
Geschwindigkeit	
1 km/h	0.620 mph
Drehmoment	
1 Nm	0.740 ft.lbs

A nameplate listing the Model Number, Item Number, Revision, and Serial Number is attached to each unit. Please record the information found on this plate so it will be available should the nameplate become lost or damaged. When ordering parts or requesting service information, you will always be asked to specify the model, item number, revision number, and serial number of the unit.

Part Numbers appearing in boldface type are recommended spare parts. This means that these parts are subject to wear under normal operating conditions and may require periodic service or replacement. It is recommended that these items be stocked to meet the expected service requirements of this model. Actual stocking quantities of these and other parts used in more extensive repairs will depend on the service practices of each customer.

My machine's numbers are:



1. Model
2. Revision
3. Item No.
4. Serial No.

Conversion table

Volume unit	
1 ml	0.034 US fl.oz.
1 l	0.260 gal
Unit of length	
1 mm	0.039 in
1 m	3.280 ft
Weight	
1 kg	2.200 lbs
1 g	0.035 oz
Speed	
1 km/h	0.620 mph
Torque	
1 Nm	0.740 ft.lbs

Una placa de identificación con el modelo, número de referencia, nivel de revisión y número de serie ha sido añadida en cada máquina. Favor de anotar los datos en la placa en caso de que la placa de identificación sea destruida o perdida. En todos los pedidos para repuestos necesita siempre el modelo, el número de referencia, el nivel de revisión y el número de serie de la máquina en cuestión.

Los números de partes en negritas en las Listas Ilustradas de Partes son los repuestos recomendados, esto quiere decir que estas partes se desgastarán bajo circunstancias de funcionamiento normales y pueden requerir servicio periódico o su reemplazo. Se recomienda que el cliente mantenga un abastecimiento adecuado de estas partes para poder satisfacer la demanda requerida por el servicio a la máquina. La cantidad de repuestos que el cliente necesitará para reparaciones dependerá de la póliza de servicio de cada cliente.

Los números de mi máquina son:



1. Modelo
2. Nivel de revisión
3. Número de referencia
4. Número de Serie

Tabla de conversión

Unidad de volumen	
1 ml	0.034 US fl.oz.
1 l	0.260 gal
Unidad de longitud	
1 mm	0.039 in
1 m	3.280 ft
Peso	
1 kg	2.200 lbs
1 g	0.035 oz
Velocidad	
1 km/h	0.620 mph
Par de apriete	
1 Nm	0.740 ft.lbs

Une plaque signalétique mentionnant le modèle, le numéro de référence, le niveau de revision et le numéro de série est fixée sur chaque machine. Veuillez noter les informations relevées sur cette plaque de façon à ce qu'elles soient toujours disponibles si la plaque signalétique venait à être perdue ou endommagée. Lorsque vous commandez des pièces détachées ou vous sollicitez des informations après-vente, on vous demandera toujours de préciser le modèle, le numéro de référence, le niveau de revision et le numéro de série de la machine.

Les numéros de pièces imprimés en caractères gras dans les Listes des Pièces Détachées de ce manuel sont les pièces détachées recommandées par la Wacker. Cela veut dire que ces pièces sont sujettes à usure dans des conditions de travail normales et peuvent nécessiter de l'entretien ou leur remplacement. Nous recommandons que vous disposiez d'un stock de ces pièces pour pouvoir satisfaire la demande d'entretien de cette machine. Le client doit décider lui-même de la quantité exacte de pièces de rechange qu'il disposera dans ses stocks.

Les numéros de ma machine sont :



1. Typ
2. Version
3. Artikel-Nr.
4. Maschinen-Nr.

Table de conversion

Unité de volume	
1 ml	0.034 US fl.oz.
1 l	0.260 gal
Unité de longueur	
1 mm	0.039 in
1 m	3.280 ft
Poids	
1 kg	2.200 lbs
1 g	0.035 oz
Vitesse	
1 km/h	0.620 mph
Couple de serrage	
1 Nm	0.740 ft.lbs

Vorderbandage Kpl. Front drum cpl. Tambor delantero compl. Tambour avant compl.	10
---	----

Hinterbandage Kpl. Rear drum cpl. Tambor de atrás compl. Tambour arrière compl.	12
---	----

Erreger Kpl. Exciter cpl. Excitador compl. Excitatrice compl.	14
---	----

Unterer Rahmen Kpl. Lower frame cpl. Chasis inferior compl. Châssis inférieur compl.	16
--	----

Motorkasten Engine compartment Caja de motor Boîte de moteur	18
---	----

Aufbau Kpl. Upper frame cpl. Armazón compl. Châssis compl.	22
--	----

Hydraulik-Rohrleitung Hydraulic piping Tubería hidráulica Canalisation hydraulique	26
---	----

Berieselungsanlage Kpl. Water system cpl. Sistema de rociado compl. Système diffuseur compl.	30
--	----

Oberer Führungsbügel Kpl. Upper handle cpl. Manija superior compl. Guidon supérieur compl.	32
--	----

Unterer Führungsbügel Kpl. Lower handle cpl. Manija inferior Guidon inférieur compl.	34
--	----

Aufkleber Labels Calcomanias Autocollants	38
--	----

Yanmar-Motor
Engine-yanmar
Motor yanmar
Moteur yanmar

Zylinderblock Cylinder block Bloque del motor Bloc de culasse	40
--	----

Schraubverschluß Drain plug Tapón roscado compl. Bouchon compl.	42
---	----

Zylinderkopf/Deckel Cylinder head/cover Culata/tapa Culasse /couverture	44
--	----

Luftfilter Air cleaner Filtro del aire Filtre à air	48
--	----

Auspufftopf Muffler Silenciador Pot d'échappement	50
--	----

Kurbelwelle Crankshaft Cigüeñal Vilebrequin	52
--	----

Nockenwelle Camshaft Arbol de levas Arbre à cames	54
--	----

Kolben Piston Pistón Piston	56
--	----

Schwungrad Flywheel Volante Volant	58
---	----

Erregerwelle Balance shaft Eje del excitador Arbre de l'excitatrice	60
--	----

Ölpumpe Oil pump Bomba de aceite Pompe à huile	62
---	----

Öldrucksender Oil pressure switch Transmisor de presión de aceite Transmetteur à pression d'huile	64
--	----

Deckel Cover Tapa Couvercle	66
--	----

Lüftergehäuse Blower housing Cubierta Bouclier	68
---	----

Kraftstoffhahn Fuel valve Grifo de combustible Robinet de carburant	70
--	----

Kraftstofftank Fuel tank Depósito de combustible Réservoir de carburant	72
--	----

Regler Governor Regulador Régulateur	74
---	----

Reversierstarter Recoil starter Arrancador Démarreur	76
---	----

Starter Starter Arrancador Démarreur	78
---	----

Elektrische Anlagen Electrical Sistema eléctrico Électrique	80
--	----

Stator Stator Estator Stator	82
---	----

Dichtungen Gaskets Empaques Joints	84
---	----

Sonderzubehör Accessories Accesorios Accessoires	
---	--

Schutzsatz Protection kit Juego de protección Jeu de protection	86
--	----

Vorderbandage Kpl.
Front drum cpl.
Tambor delantero compl.
Tambour avant compl.

RD7YE

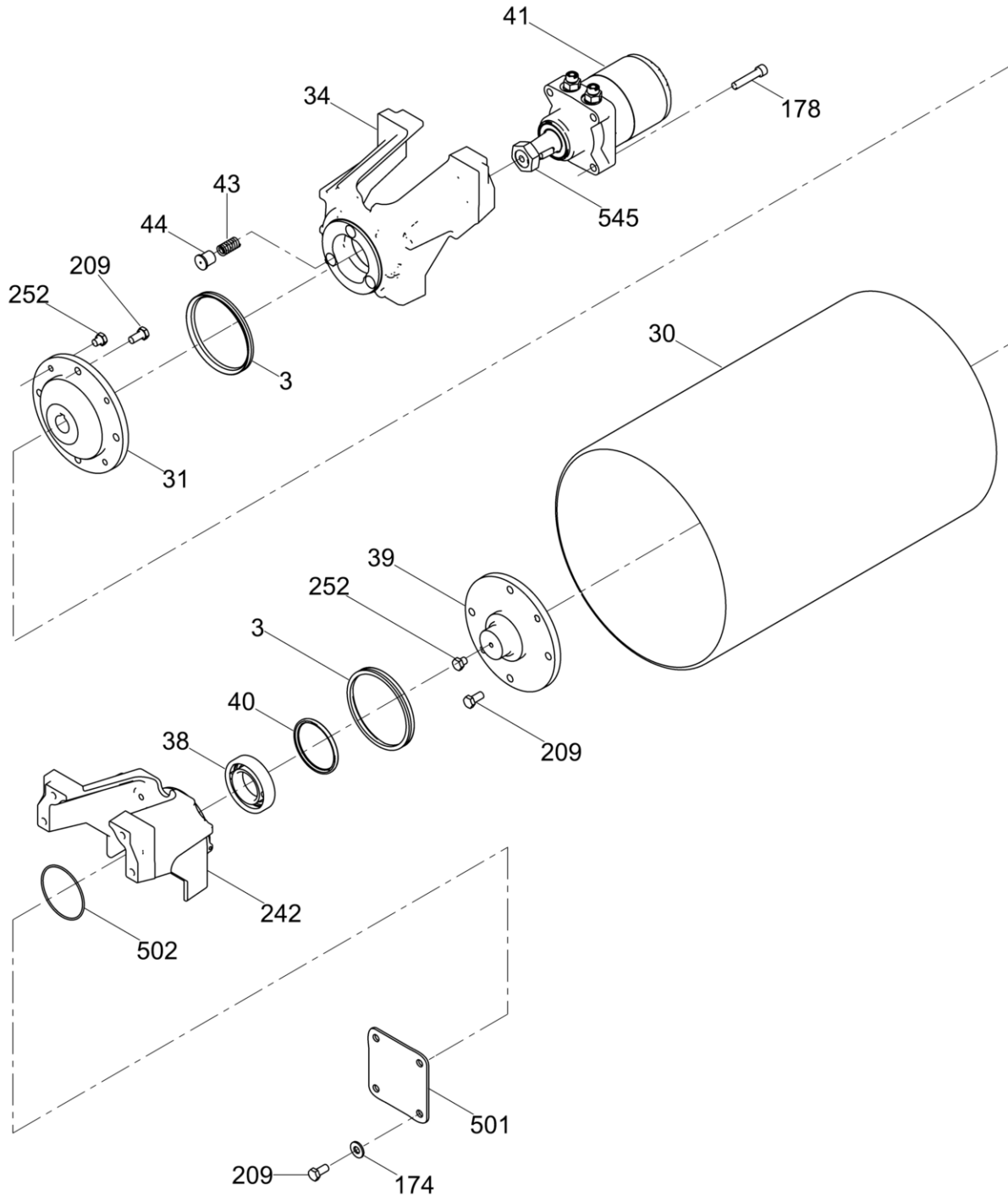

5100044068_01

Pos. Ref.	Artikel Nr. Part No.	Qty.	Unit	Beschreibung Descripción	Description Description	Abm. Measur.	Norm Standard
						Drehm. Torque	Schmierstoff Sealant
3	5000111811	4	PC	Dichtungsring Anillo sellador	Ring seal Rondelle à étancher		
30	5100042730	2	PC	Bandage Tambor del rodillo	Drum Tambour		
31	5200011900	2	PC	Antriebsnabe El cubo	Drive hub Le moyeu d'entraînement		
34	5200009583	2	PC	Bandagenträger Soporte del tambor	Drum support Support de tambour		
38	5100013997	2	PC	Zylinderlager Rodamiento del cilindro	Cylinder bearing Roulement de cylindre		
39	5200011902	2	PC	Nicht-Antriebsnabe No el cubo	Non-drive hub Non-moyeu d'entraînement		
40	5200015820	2	PC	Wellendichtring Sello del eje	Shaft seal Bague d'étanchéité		
41	5200009746	2	PC	Hydraulikmotor Motor hidráulico	Hydraulic motor Moteur hydraulique		
43	5200023523	6	PC	Druckfeder Resorte de compresión	Compression spring Ressort de pression		
44	5200023630	6	PC	Buchse Buje	Buchse Douille		
77	5000012368	2	PC	Sechskantschraube Tornillo hexagonal	Hexagonal head cap screw Vis à tête hexagonale	M12 x 20 86Nm/63ft.lbs	DIN933
89	5000118005	1	PC	Feder Resorte	Spring Ressort		
90	5000013769	1	PC	Spannstift Pasador de sujeción	Spring pin Goupille élastique	6 x 30	DIN1481
91	5100042841	1	PC	Handgriff Manija	Handle Poignée		
93	5000118006	1	PC	Anschlußsteil Conector	Connector Connecteur		
94	5000118004	1	PC	Bolzen Perno	Bolt Boulon		
139	5000010620	2	PC	Scheibe Arandela	Flat washer Rondelle	12	ISO7090
175	5002004705	4	PC	Kegelschmiernippel Grasera	Grease fitting Graisseur	AM6	DIN71412
178	5000111979	8	PC	Zylinderschraube Tornillo cilíndrico	Socket head cap screw Vis à tête cylindrique	M12 x 60 85Nm/63ft.lbs	ISO4762
209	5000016433	22	PC	Sechskantschraube Tornillo hexagonal	Hexagonal head cap screw Boulon à tête hexagonale	M12 x 25 120Nm/89ft.lbs	
242	5100042842	2	PC	Bandagenträger Soporte del tambor	Drum support Support de tambour		
252	5000119193	8	PC	Schraube Tornillo	Screw Vis	M12 x 12 120Nm/89ft.lbs	
501	5100042840	1	PC	Lagerdeckel Tapa del rodamiento	Bearing cover Tapa del rodamiento		
502	5000031880	2	PC	O-Ring Anillo-o	O-ring Joint torique	96 x 3	
503	5100043571	2	PC	Schraube Tornillo	Screw Vis		
545	5100042137	2	PC	Mutter Tuerca	Nut Écrou	1-1/2in	

Hinterbandage Kpl.
Rear drum cpl.
Tambor de atrás compl.
Tambour arrière compl.

RD7YE

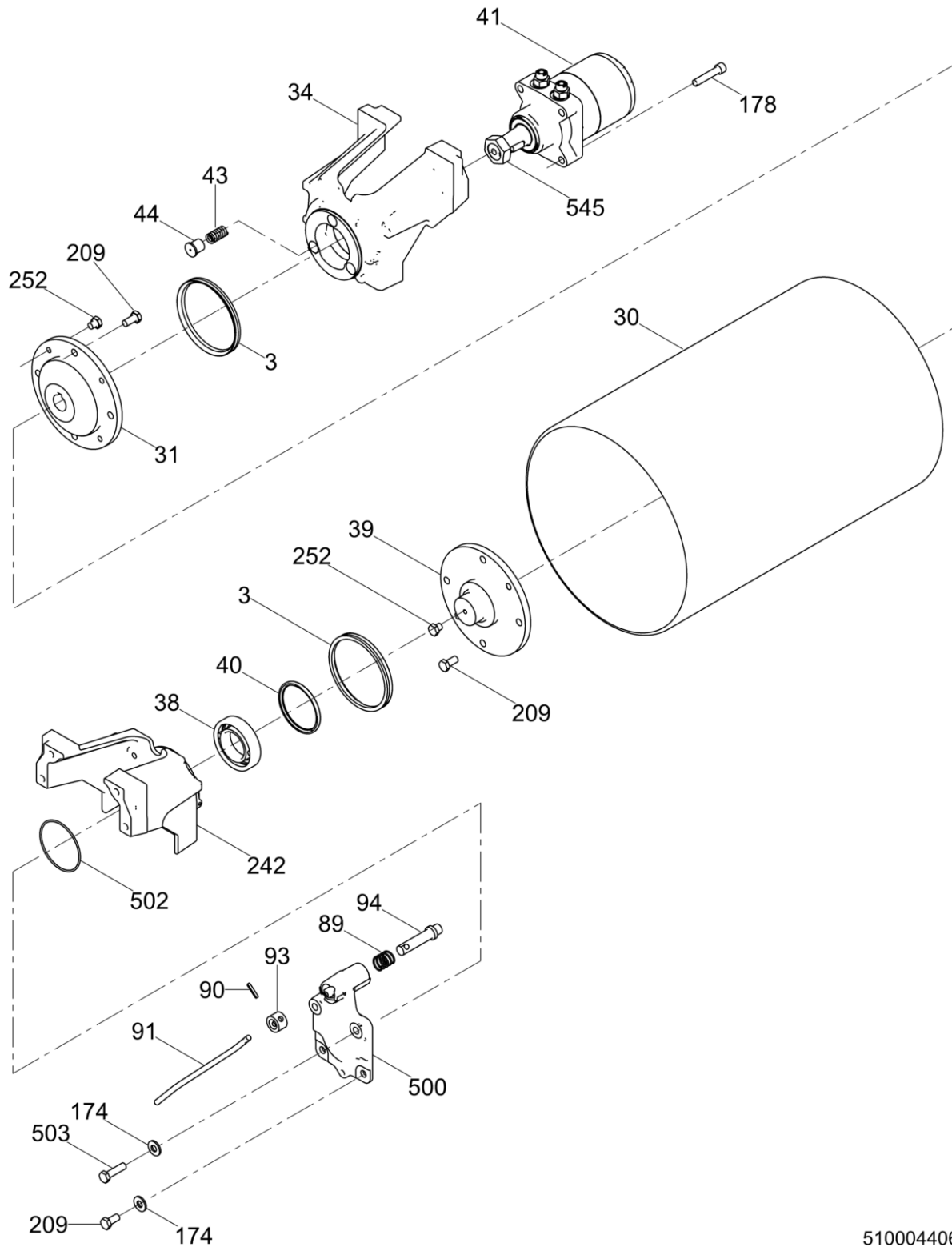

5100044067_01

Pos. Ref.	Artikel Nr. Part No.	Qty.	Unit	Beschreibung Descripción	Description Description	Abm. Measur.	Norm Standard
						Drehm. Torque	Schmierstoff Sealant
3	5000111811	4	PC	Dichtungsring Anillo sellador	Ring seal Rondelle à étancher		
30	5100042730	2	PC	Bandage Tambor del rodillo	Drum Tambour		
31	5200011900	2	PC	Antriebsnabe El cubo	Drive hub Le moyeu d'entraînement		
34	5200009583	2	PC	Bandagenträger Soporte del tambor	Drum support Support de tambour		
38	5100013997	2	PC	Zylinderlager Rodamiento del cilindro	Cylinder bearing Roulement de cylindre		
39	5200011902	2	PC	Nicht-Antriebsnabe No el cubo	Non-drive hub Non-moyeu d'entraînement		
40	5200015820	2	PC	Wellendichtring Sello del eje	Shaft seal Bague d'étanchéité		
41	5200009746	2	PC	Hydraulikmotor Motor hidráulico	Hydraulic motor Moteur hydraulique		
43	5200023523	6	PC	Druckfeder Resorte de compresión	Compression spring Ressort de pression		
44	5200023630	6	PC	Buchse Buje	Buchse Douille		
77	5000012368	2	PC	Sechskantschraube Tornillo hexagonal	Hexagonal head cap screw Vis à tête hexagonale	M12 x 20 86Nm/63ft.lbs	DIN933
89	5000118005	1	PC	Feder Resorte	Spring Ressort		
90	5000013769	1	PC	Spannstift Pasador de sujeción	Spring pin Goupille élastique	6 x 30	DIN1481
91	5100042841	1	PC	Handgriff Manija	Handle Poignée		
93	5000118006	1	PC	Anschlußsteil Conector	Connector Connecteur		
94	5000118004	1	PC	Bolzen Perno	Bolt Boulon		
139	5000010620	2	PC	Scheibe Arandela	Flat washer Rondelle	12	ISO7090
175	5002004705	4	PC	Kegelschmiernippel Grasera	Grease fitting Graisseur	AM6	DIN71412
178	5000111979	8	PC	Zylinderschraube Tornillo cilíndrico	Socket head cap screw Vis à tête cylindrique	M12 x 60 85Nm/63ft.lbs	ISO4762
209	5000016433	22	PC	Sechskantschraube Tornillo hexagonal	Hexagonal head cap screw Boulon à tête hexagonale	M12 x 25 120Nm/89ft.lbs	
242	5100042842	2	PC	Bandagenträger Soporte del tambor	Drum support Support de tambour		
252	5000119193	8	PC	Schraube Tornillo	Screw Vis	M12 x 12 120Nm/89ft.lbs	
500	5100042890	1	PC	Gehäuse Caja	Housing Carter		
502	5000031880	2	PC	O-Ring Anillo-o	O-ring Joint torique	96 x 3	
503	5100043571	2	PC	Schraube Tornillo	Screw Vis		
545	5100042137	2	PC	Mutter Tuerca	Nut Écrou	1-1/2in	

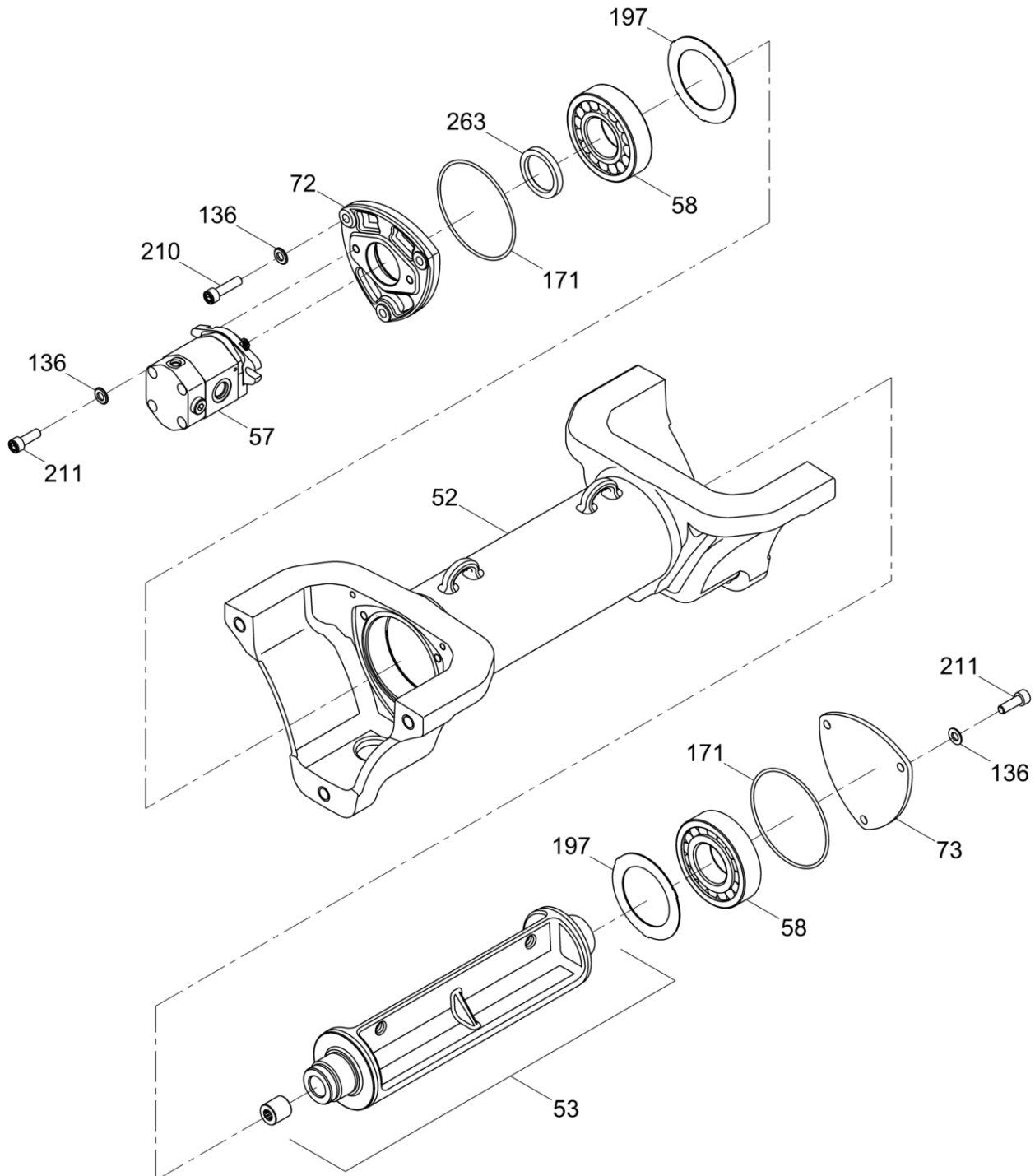

200_5200015241100003

Pos. Ref.	Artikel Nr. Part No.	Qty.	Unit	Beschreibung Description	Description Description	Abm. Measur.	Norm Standard
						Drehm. Torque	Schmierstoff Sealant
52	5200011116	1	PC	Erregergehäuse Caja de excitador	Exciter housing Carter d'excitatrice		
53	5100043375	1	PC	Erregerwelle Kpl Eje & acoplamiento	Shaft w/coupling Arbre & accouplement		
57	5200009747	1	PC	Erregermotor Motor excitador	Exciter motor Moteur d'excitatrice		
58	5100013998	2	PC	Zylinderlager Rodamiento del cilindro	Cylinder bearing Roulement de cylindre		
72	5200016005	1	PC	Adapterplatte Placa adaptador	Adapter plate Plaque d'adaptateur		
73	5200016006	1	PC	Blanke Scheibe Arandela	Housing cover Rondelle plate		
136	5000010621	8	PC	Scheibe Arandela	Washer Rondelle		
171	5200015975	2	PC	O-Ring Anillo-o	O-ring Joint torique		
197	5200015977	2	PC	Sicherungsring Anillo de retención	Retaining ring Bague d'arrêt		
210	5000011532	3	PC	Zylinderschraube Tornillo cilíndrico	Cheese head screw Vis à tête cylindrique	M10 x 40 49Nm/36ft.lbs	ISO4762
211	5000012382	5	PC	Zylinderschraube Tornillo cilíndrico	Socket head cap screw Vis à tête cylindrique	M10 x 30 36Nm/27ft.lbs	
263	5000072113	1	PC	Wellendichtring Sello del eje	Shaft seal Bague d'étanchéité	45 x 60 x 8	

Unterer Rahmen Kpl.
 Lower frame cpl.
 Chassis inferior compl.
 Châssis inférieur compl.

RD7YE

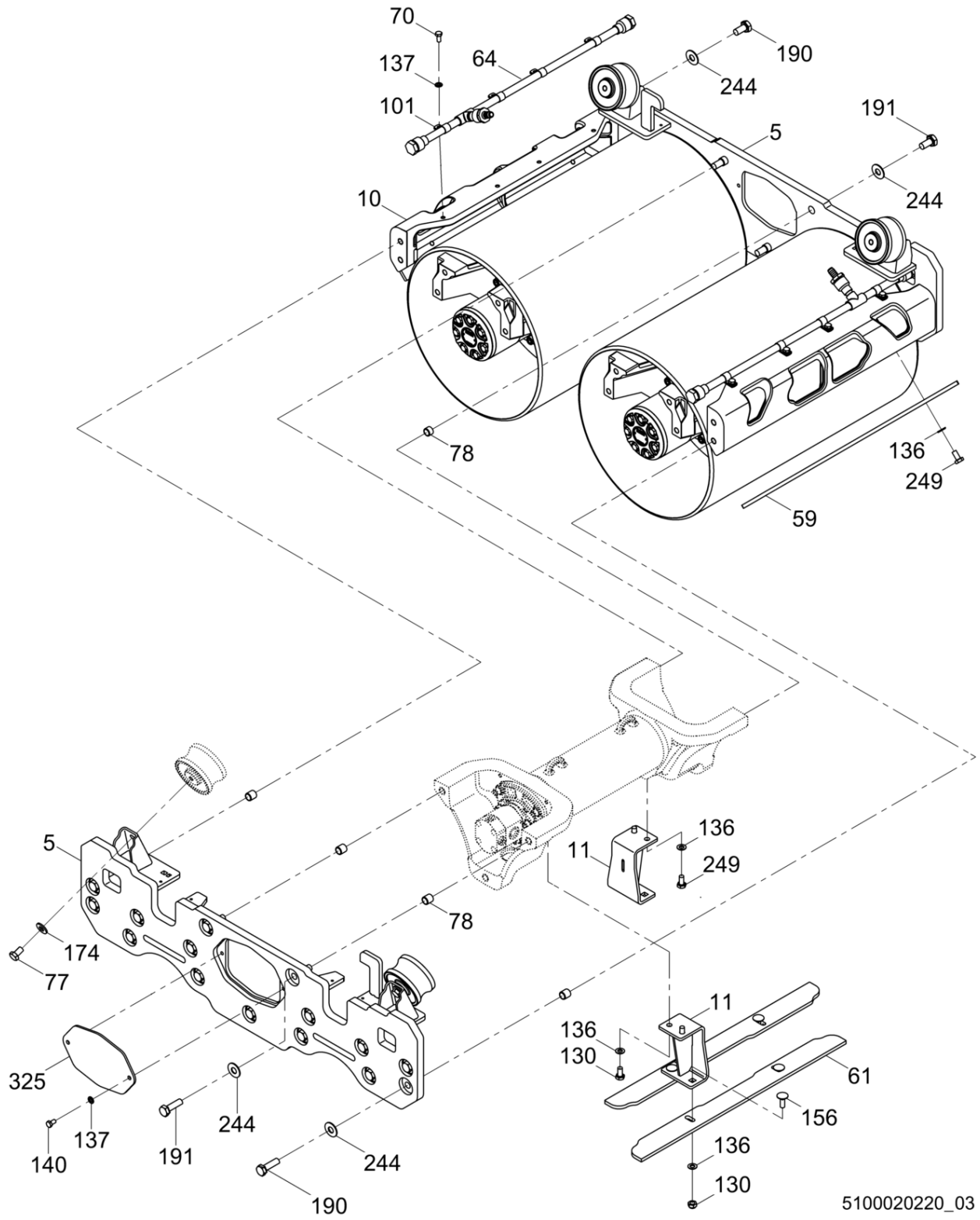

5100020220_03

Pos. Ref.	Artikel Nr. Part No.	Qty.	Unit	Beschreibung Description	Description Description	Abm. Measur.	Norm Standard
						Drehm. Torque	Schmierstoff Sealant
5	5200009734	1	PC	Unterer Rahmen Chasis inferior	Lower frame Châssis inférieur		
9	5200009735	1	PC	Unterer Rahmen Chasis inferior	Lower frame Châssis inférieur		
10	5200011897	2	PC	Querträger Travesaño	Cross member Traverse		
11	5200015640	2	PC	Konsole Soporte	Bracket Support		
59	5200009741	2	PC	Abstreifer Barra raspadora	Scraper Racleur		
61	5200009742	2	PC	Abstreifer Barra raspadora	Scraper Racleur		
64	5100028105	2	PC	Berieselungsstange Kpl. Barra de rociado comp.	Spray bar cpl. Barre d'arrosage comp.		
70	5000012361	8	PC	Sechskantschraube Tornillo hexagonal	Hexagonal head cap screw Vis à tête hexagonale	M8 x 16 25Nm/18ft.lbs	DIN933
77	5000012368	4	PC	Sechskantschraube Tornillo hexagonal	Hexagonal head cap screw Vis à tête hexagonale	M12 x 20 86Nm/63ft.lbs	DIN933
78	5200024447	6	PC	Paßstift Espiga	Dowel pin Cheville		
130	5000010365	4	PC	Sicherungsmutter Contratuerca	Lock nut Contre-écrou	M10	DIN980
136	5000010621	14	PC	Scheibe Arandela	Washer Rondelle		
137	5000010622	10	PC	Scheibe Arandela	Flat washer Rondelle		
140	5000160484	2	PC	Sechskantschraube Tornillo hexagonal	Hexagonal head cap screw Boulon à tête hexagonale	M8 x 14	
156	5200017517	4	PC	Schloßschraube Tornillo de carruaje	Carriage bolt Boulon brut à tête bombée		
174	5000031565	4	PC	Spannscheibe Arandela elástica	Lockwasher Rondelle de ressort	12	DIN6796
190	5200016245	28	PC	Schraube Tornillo	Screw Vis	M14 x 35 190Nm/140ft.lbs	
191	5000118606	6	PC	Sechskantschraube Tornillo hexagonal	Hexagonal head cap screw Boulon à tête hexagonale	M14 x 45	DIN933
192	5000163956	8	PC	Schelle Abrazadera	Clamp Agrafe		
244	5000080596	34	PC	Federring Federring	Lock washer Rondelle de ressort	14	DIN6796
249	5000157161	10	PC	Sechskantschraube Tornillo hexagonal	Hexagonal head cap screw Boulon à tête hexagonale	M10 x 20	
325	5200015199	1	PC	Deckel Tapa	Cover Couvercle		

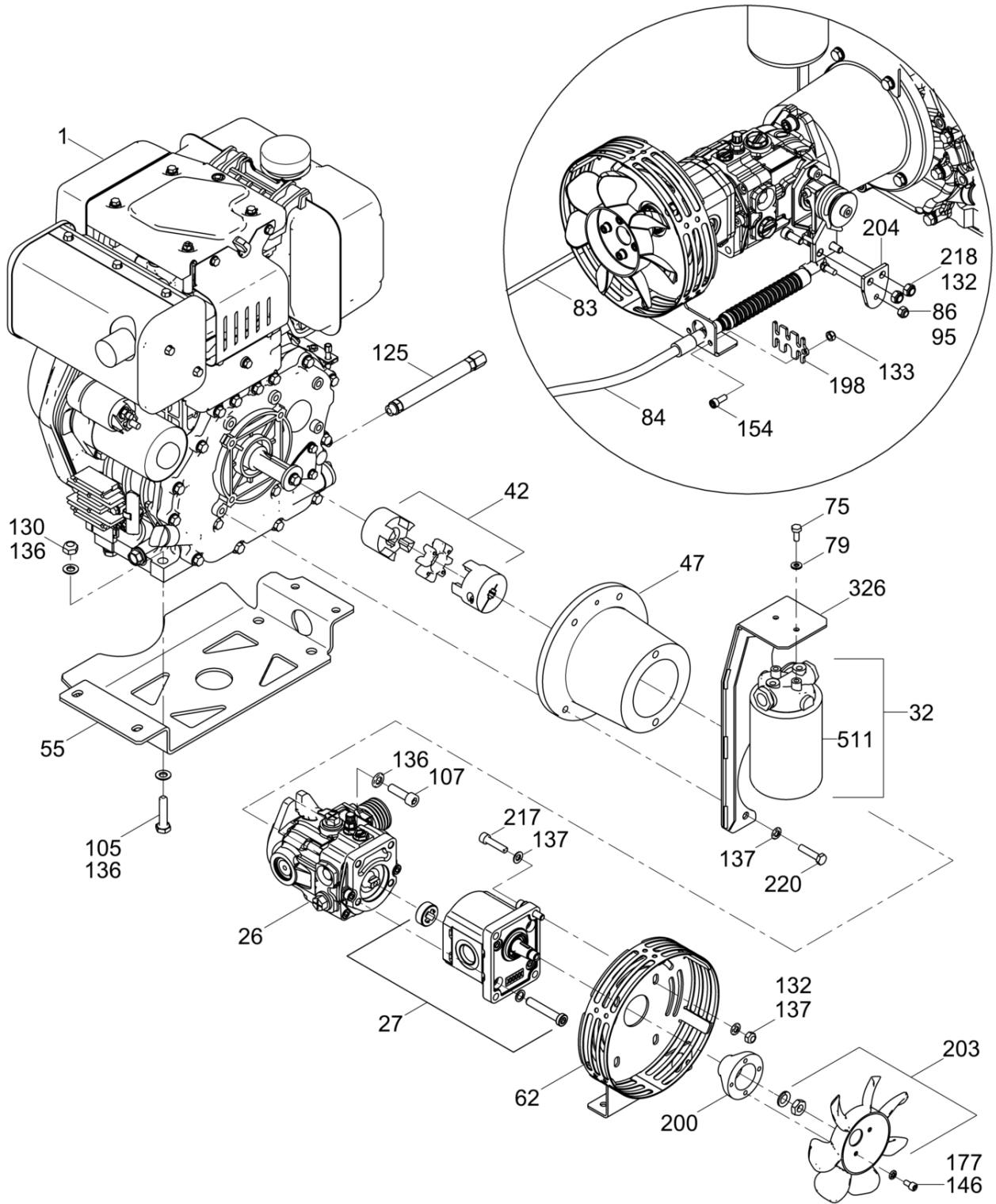

5100031799_02

Pos. Ref.	Artikel Nr. Part No.	Qty.	Unit	Beschreibung Description	Description Description	Abm. Measur.	Norm Standard
						Drehm. Torque	Schmierstoff Sealant
1	5100027439	1	PC	Yanmar-Motor Motor yanmar	Engine-yanmar Moteur yanmar		
26	5100047071	1	PC	Antriebspumpe Bomba de accionamiento	Drive pump Pompe d'entraînement		
27	5100047070	1	PC	Erregerpumpe Bomba del excitador	Exciter pump Pompe de l'excitatrice		
32	5200016308	1	PC	Hydraulikfilter Kpl. Filtro hidráulico compl.	Hydraulic filter cpl. Filtre hydraulique compl.		
42	5100027379	1	PC	Kupplung Acoplamiento	Coupling Accouplement		
47	5100028191	1	PC	Pumpe/Motor Adapter Bomba/motor adaptador	Pump/motor adapter Pompe/moteur adaptateur		
55	5100027435	1	PC	Motorträger Soporte de motor	Engine mount Support pour moteur		
62	5100029090	1	PC	Konsole Soporte	Bracket Support		
75	5200021953	2	PC	Sechskantschraube Tornillo hexagonal	Hexagonal head cap screw Boulon à tête hexagonale		
79	5000058381	2	PC	Spannscheibe Arandela elástica	Lockwasher Rondelle de ressort	6	DIN6796
82	5100028123	1	PC	Bowdenzug Cable del acelerador	Throttle cable Câble des gaz		
84	5100028837	1	PC	Reisekabel Cable de viaje	Travel cable Câble de voyage		
86	5000114114	1	PC	Kugelgelenk Articulación de rótula	Ball joint Accouplement articulé		
95	5000028746	1	PC	Sicherungsmutter Contratuerca	Lock nut Contre-écrou	1/4-28in	
105	5000011319	4	PC	Sechskantschraube Tornillo hexagonal	Hexagonal head cap screw Vis à tête hexagonale	M10 x 45 49Nm/36ft.lbs	DIN931
107	5000164600	2	PC	Zylinderschraube Tornillo cilíndrico	Socket head cap screw Vis à tête cylindrique	M10 x 35	
125	5100028679	1	PC	Motorablassschlauch Manguera de drenaje del motor	Engine drain hose Vidange du moteur flexible		
130	5000010365	4	PC	Sicherungsmutter Contratuerca	Lock nut Contre-écrou	M10	DIN980
132	5000010367	9	PC	Sechskantmutter Tuerca hexagonal	Hexagon nut Écrou hexagonal	M8	DIN985
133	5000010368	2	PC	Sechskantmutter Tuerca hexagonal	Hexagon nut Écrou hexagonal	M6	DIN985
136	5000010621	10	PC	Scheibe Arandela	Washer Rondelle		
137	5000010622	14	PC	Scheibe Arandela	Flat washer Rondelle		
146	5000011554	4	PC	Zylinderschraube Tornillo cilíndrico	Cheese head screw Vis à tête cylindrique		
154	5000011553	2	PC	Zylinderschraube Tornillo cilíndrico	Cheese head screw Vis à tête cylindrique		
177	5000010624	4	PC	Scheibe Arandela	Flat washer Rondelle		
198	5100028125	1	PC	Platte Placa	Plate Plaque		
200	5200015688	1	PC	Adapter Adaptador	Adapter Raccord		
203	5200011470	1	PC	Gebläserad Ventilador	Fan Ventilateur	7,00in	

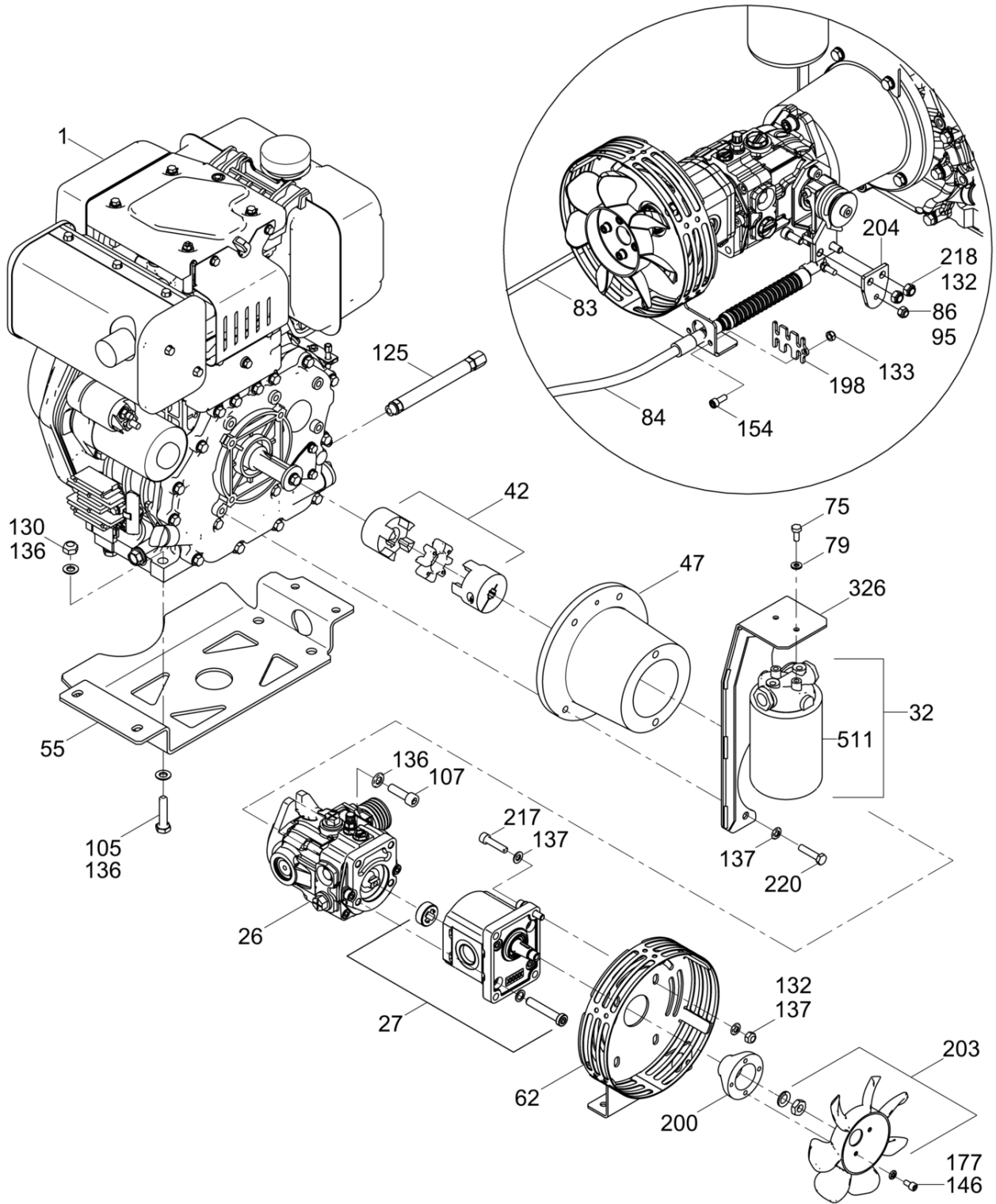

5100031799_02

Pos. Ref.	Artikel Nr. Part No.	Qty.	Unit	Beschreibung Descripcion	Description Description	Abm. Measur.	Norm Standard
						Drehm. Torque	Schmierstoff Sealant
204	5200014788	1	PC	Hebel Palanca	Lever Levier		
217	5000011540	2	PC	Zylinderschraube Tornillo cilíndrico	Cheese head screw Vis à tête cylindrique	M8 x 35 25Nm/18ft.lbs	ISO4762
218	5000011543	2	PC	Zylinderschraube Tornillo hueco	Socket head screw Vis à six-pans creux	M8 x 20 24Nm/18ft.lbs	ISO4762
220	5000011542	9	PC	Zylinderschraube Tornillo cilíndrico	Cheese head screw Vis à tête cylindrique		
326	5100027436	1	PC	Filterhalterung Ménsula del filtro	Filter bracket Support de filtre		
511	5200016307	1	PC	Hydraulikfilter Filtro hidráulico	Hydraulic filter Filtre hydraulique		

Aufbau Kpl.
 Upper frame cpl.
 Armazón compl.
 Châssis compl.

RD7YE

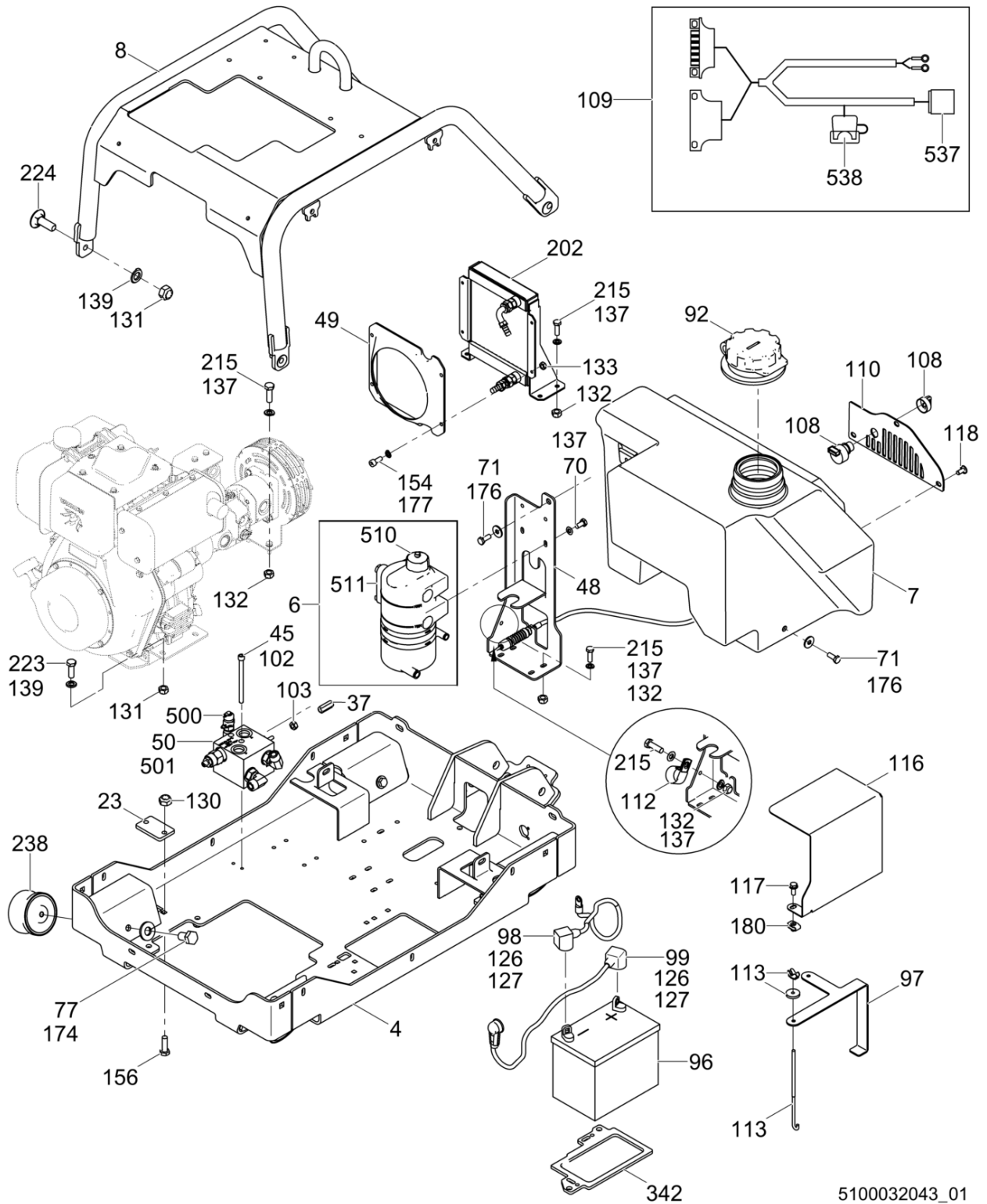

5100032043_01



Pos. Ref.	Artikel Nr. Part No.	Qty.	Unit	Beschreibung Description	Description Description	Abm. Measur.	Norm Standard
						Drehm. Torque	Schmierstoff Sealant
4	5100027391	1	PC	Oberer Rahmen Chasis superior	Upper frame Châssis supérieur		
6	5100046197	1	PC	Hydrauliktank Tanque hidráulico	Hydraulic tank Réservoir hydraulique		
7	5200011121	1	PC	Wassertank Tanque del agua	Water tank Réservoir à eau		
8	5100027392	1	PC	Schutzrahmen Chasis protector	Protective frame Cadre de protection		
23	5200019837	2	PC	Platte Placa	Plate Plaque		
37	5200013821	1	PC	Kupplung Acoplamiento	Coupling Accouplement		
45	5200021852	2	PC	Zylinderschraube Tornillo hueco	Socket head screw Vis à six-pans creux	1/4-20 x 3,0in	
48	5100029092	1	PC	Konsole Ménsula	Mounting bracket Support		
49	5200013843	1	PC	Haube Guardera	Shroud Carénage		
50	5200015008	1	PC	Hydraulikverteiler Distribuidor hidráulico	Hydraulic manifold Tubulure hydraulique		
70	5000012361	4	PC	Sechskantschraube Tornillo hexagonal	Hexagonal head cap screw Vis à tête hexagonale	M8 x 16 25Nm/18ft.lbs	DIN933
71	5000012362	5	PC	Sechskantschraube Tornillo hexagonal	Hexagonal head cap screw Vis à tête hexagonale	25Nm/18ft.lbs	
77	5000012368	4	PC	Sechskantschraube Tornillo hexagonal	Hexagonal head cap screw Vis à tête hexagonale	M12 x 20 86Nm/63ft.lbs	DIN933
92	5100030251	1	PC	Tankdeckel Tapa del tanque	Water tank cap Chapeau de réservoir		
96	5000118088	1	PC	Batterie Batería	Battery Batterie	12VDC	
97	5200017428	1	PC	Batteriestütze Soporte de batería	Battery bracket Support de batterie		
98	5200020697	1	PC	Minusbatteriekabel Cable negativo de batería	Negative battery cable Câble négatif de batterie		
99	5100028188	1	PC	Plusbatteriekabel Cable positivo de batería	Positive battery cable Câble positif de batterie		
102	5000025633	2	PC	Sicherungsmutter Contratuerca	Lock nut Contre-écrou	1/4-20in	
103	5000025615	1	PC	Mutter Tuerca	Nut Écrou	1/4-20in	
108	5000158782	1	PC	Schlüsselschalter Interruptor de llave	Key switch Interrupteur de clé		
109	5100028133	1	PC	Hauptkabelbaum Conjunto de cables principal	Main wiring harness Harnais de fils électriques pr		
110	5200009701	1	PC	Konsole Soporte	Bracket Support		
112	1000062662	1	PC	Rohrschelle Colgador de tubo	Pipe clamp Bride de fixation		
113	5000157185	2	PC	J-Bolzen Perno forma j	J-bolt Boulon j	0,25-8	
116	5200011112	1	PC	Batterieisolator Protector de la batería	Battery protector Protecteur de la batterie		
117	5000028404	2	PC	Schraube Tornillo	Screw Vis	M8 x 20 25Nm/18ft.lbs	
118	5000079363	3	PC	Schraube Tornillo	Screw Vis	M8 x 16 25Nm/18ft.lbs	

Aufbau Kpl.
 Upper frame cpl.
 Armazón compl.
 Châssis compl.

RD7YE

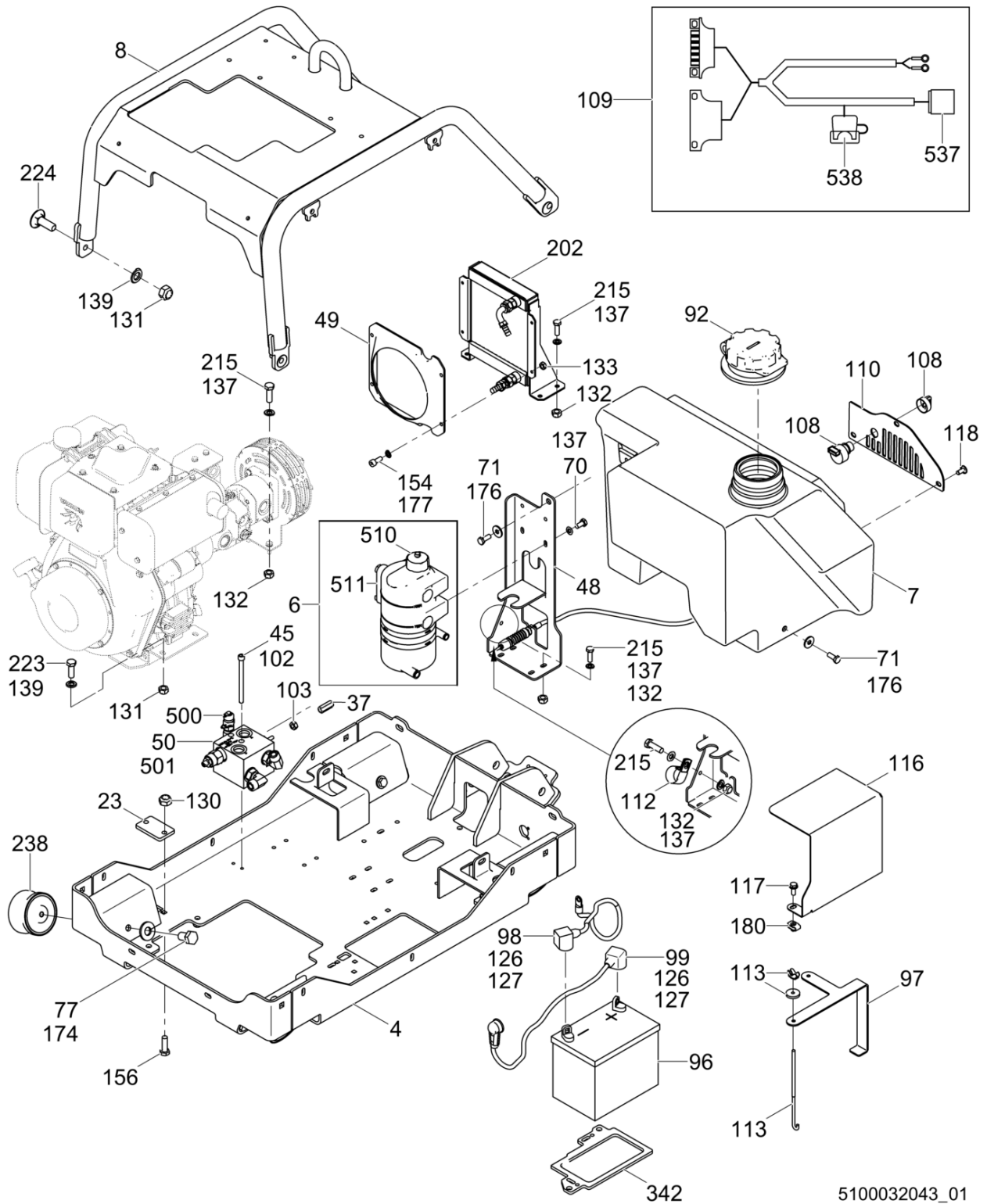

5100032043_01

Pos. Ref.	Artikel Nr. Part No.	Qty.	Unit	Beschreibung Description	Description Description	Abm. Measur.	Norm Standard
						Drehm. Torque	Schmierstoff Sealant
126	5000030066	2	PC	Sechskantmutter Contratuerca	Locknut Contre-écrou	M8	
127	5000111845	2	PC	Schloßschraube Tornillo de carruaje	Carriage bolt Boulon brut à tête bombée	M8 x 25	
130	5000010365	4	PC	Sicherungsmutter Contratuerca	Lock nut Contre-écrou	M10	DIN980
131	5000010366	8	PC	Sechskantmutter Tuerca hexagonal	Hexagon nut Écrou hexagonal	M12X1.75	DIN985
132	5000010367	13	PC	Sechskantmutter Tuerca hexagonal	Hexagon nut Écrou hexagonal	M8	DIN985
133	5000010368	4	PC	Sechskantmutter Tuerca hexagonal	Hexagon nut Écrou hexagonal	M6	DIN985
137	5000010622	22	PC	Scheibe Arandela	Flat washer Rondelle		
139	5000010620	12	PC	Scheibe Arandela	Flat washer Rondelle	12	ISO7090
154	5000011553	4	PC	Zylinderschraube Tornillo cilíndrico	Cheese head screw Vis à tête cylindrique	10Nm/7ft.lbs	
156	5200017517	4	PC	Schloßschraube Tornillo de carruaje	Carriage bolt Boulon brut à tête bombée		
174	5000031565	4	PC	Spannscheibe Arandela elástica	Lockwasher Rondelle de ressort	12	DIN6796
176	5000010374	5	PC	Scheibe Arandela	Flat washer Rondelle		
177	5000010624	4	PC	Scheibe Arandela	Flat washer Rondelle		
180	5200002421	2	PC	Klemmutter Sujetador	Clip nut Agrafe	M8 X 1/4	
202	5200011449	1	PC	Ölkühler Refrigerador de aceite	Oil cooler Réfrigérant à l'huile		
215	5000011457	11	PC	Sechskantschraube Tornillo hexagonal	Hexagonal head cap screw Vis à tête hexagonale	M8 x 25 25Nm/18ft.lbs	
223	5000011422	4	PC	Sechskantschraube Tornillo hexagonal	Hexagonal head cap screw Vis à tête hexagonale	M12 x 35 86Nm/63ft.lbs	DIN933
224	5200016002	4	PC	Schloßschraube Tornillo de carruaje	Carriage bolt Boulon brut à tête bombée	M12 x 35	
238	5002004814	4	PC	Gimmetall-Kerblager Mit Bund Amortiguador	Shockmount Silentbloc	100 x 58	
342	5200017205	1	PC	Abstandsstück Espaciador	Spacer Entretoise		
500	5000182738	1	PC	Prüfverschraubung Mit Kappe Unión de prueba con tapa	Test fitting w/cap Raccord d'essai avec couvercle	M16 x 2, 7/16-20 UNC	
501	5100018765	1	PC	Dichtungssatz Juego de empaques	Seal kit Jeu de joints		
510	5100021564	1	PC	Kappe Tapa	Cap Couvercle		
511	5100047178	1	PC	Ölschauglas Mirilla del nivel de aceite	Sightglass Verre-regard d'huile		
537	5200002190	1	PC	Alarm Alarma	Alarm Avertisseur		
538	5000077219	1	PC	Sicherung Fusible	Fuse Fusible	15A	

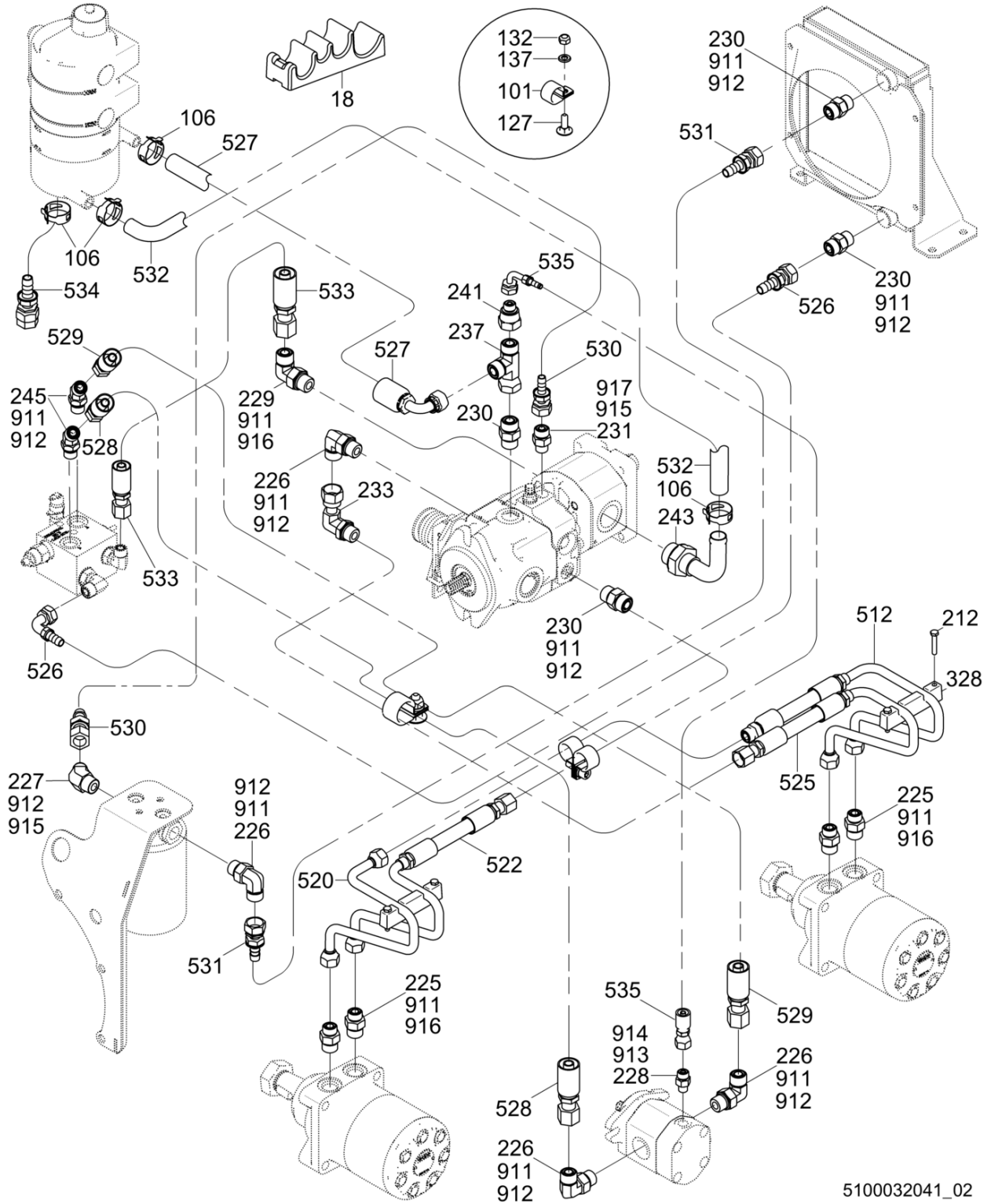

5100032041_02

Pos. Ref.	Artikel Nr. Part No.	Qty.	Unit	Beschreibung Description	Description Description	Abm. Measur.	Norm Standard
						Drehm. Torque	Schmierstoff Sealant
18	5100028189	1	PC	Schlauchschelle Abrazaderas de manguera	Hose clamp Agrafe de tuyau		
101	5000110458	3	PC	Schelle Abrazadera	Clamp Agrafe		
106	5200025641	4	PC	Schelle Abrazadera	Clamp Agrafe		
127	5000111845	3	PC	Schloßschraube Tornillo de carruaje	Carriage bolt Boulon brut à tête bombée	M8 x 25	
132	5000010367	3	PC	Sechskantmutter Tuerca hexagonal	Hexagon nut Écrou hexagonal	M8	DIN985
137	5000010622	3	PC	Scheibe Arandela	Flat washer Rondelle		
212	5000011368	4	PC	Sechskantschraube Tornillo hexagonal	Hexagonal head cap screw Vis à tête hexagonale	M6 x 35 10Nm/7ft.lbs	DIN931
225	5000079875	4	PC	Hydraulikverschraubung Unión hidráulico	Hydraulic fitting Raccord hydraulique	No.8 x 10	
226	5000111272	4	PC	Hydraulikrohrkrümmer Codo hidráulico	Hydraulic elbow fitting Coude hydraulique	SAE No.8 x 90	
227	5100032170	1	PC	Hydraulikrohrkrümmer 45 Codo hidráulico 45	Hydraulic elbow fitting 45 Coude hydraulique 45	45	
228	5000111282	1	PC	Hydraulikverschraubung Unión hidráulico	Hydraulic fitting Raccord hydraulique	SAE No.4	
229	5000081340	1	PC	Rohrkrümmer Codo	Elbow fitting Coude	No.8 x 10 x 90	
230	5000081583	4	PC	Verschraubung-Gerade Unión recto	Straight fitting Raccord-droit	No.8	
231	5000078816	1	PC	Zwischenverschraubung Unión con adaptador	Adapter fitting Raccord intermédiaire		
233	5200025501	1	PC	Hydraulikrohrkrümmer Codo hidráulico	Hydraulic elbow fitting Coude hydraulique	1/2 x 1/2in ORFS x 90	
237	5000163992	1	PC	T-Hydraulikverschraubung Unión hidráulico forma t	Hydraulic t-fitting Raccord hydraulique ""t""	No.8	
241	5200022118	1	PC	Hydraulikverschraubung Unión hidráulico	Hydraulic fitting Raccord hydraulique		
243	5000088342	1	PC	Verschraubung Unión	Fitting Raccord	90	
245	5100013962	2	PC	Hydraulikverschraubung Unión hidráulico	Hydraulic fitting Raccord hydraulique	No. 8 x 45	
328	5200015169	2	PC	Führung Guía	Guide Guide		
512	5100029200	1	PC	Stahlschlauch Manguera de acero	Steel hose Tuyau d'acier		
520	5100029201	1	PC	Stahlschlauch Manguera de acero	Steel hose Tuyau d'acier		
522	5100029202	1	PC	Stahlschlauch Manguera de acero	Steel hose Tuyau d'acier		
525	5100029203	1	PC	Stahlschlauch Manguera de acero	Steel hose Tuyau d'acier		
526	5200024389	1	PC	Ölkühlereinlaßschlauch Manguera de admisión del radiador de aceite	Oil cooler inlet hose Tuyau d'admission du radiateur	26,00in	
527	5200024394	1	PC	Tankauslaufschlauch Manguera de salida del tanque	Tank outlet hose Sortie du réservoir flexible	20,00in	
528	5200024391	1	PC	Exciter Motorschlauch Manguera del motor exciter	Exciter motor hose Exciter moteur flexible	33,00in	
529	5200024392	1	PC	Exciter Motorschlauch Manguera del motor exciter	Exciter motor hose Exciter moteur flexible	30,00in	

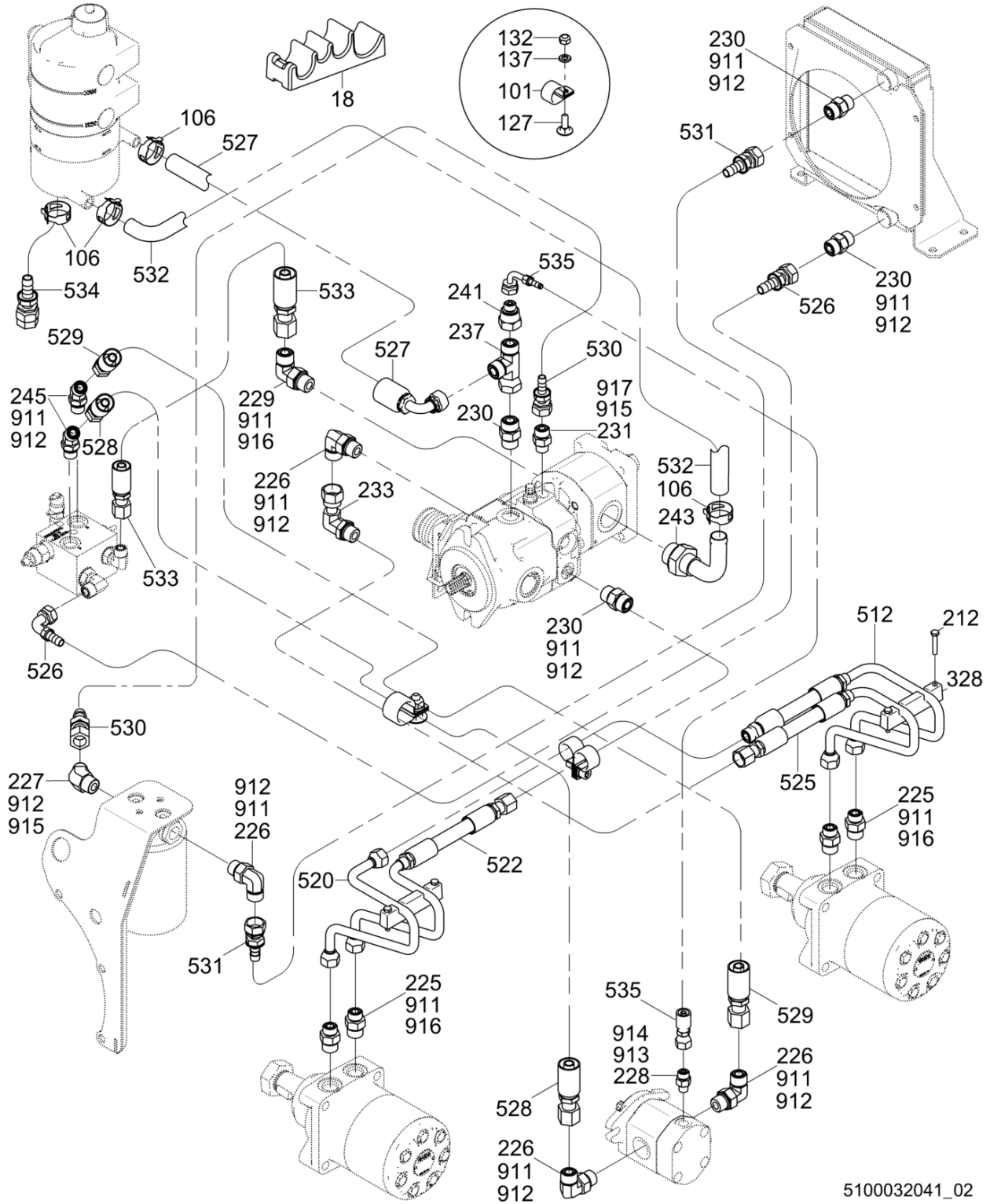

5100032041_02

Pos. Ref.	Artikel Nr. Part No.	Qty.	Unit	Beschreibung Description	Description Description	Abm. Measur.	Norm Standard
						Drehm. Torque	Schmierstoff Sealant
530	5200024388	1	PC	Pumpenschlauch Manguera de bomba	Pump hose Tuyau de pompe	12,00in	
531	5200024390	1	PC	Ölkühlerauslaßschlauch Manguera de salida del radiador de aceite	Oil cooler outlet hose Tuyau de sortie du radiateur d	20,75in	
532	5200024383	1	PC	Saugschlauch Manguera de succión	Suction hose Tuyau de succion	15,50in	
533	5200024384	1	PC	Druckschlauch Manguera de presión	Pressure hose Tuyau de pression	16,50in	
534	5200024395	1	PC	Tankablassschlauch Manguera de drenaje del tanque	Tank drain hose Vidange de la cuve le tuyau	10,00in	
535	5200024393	1	PC	Fall Ablaufschlauch Manguera de drenaje de la caja	Case drain hose Case tuyau de vidange	21,50in	
911	5000080737	1	PC	O-Ring Anillo-o	O-ring Joint torique	0,489 x 0,070in	
912	5000080732	1	PC	O-Ring Anillo-o	O-ring Joint torique	0,644 x 0,087in	
913	5000080730	1	PC	O-Ring Anillo-o	O-ring Joint torique	0,351 x 0,072in	
914	5000112267	1	PC	O-Ring Anillo-o	O-ring Joint torique	0,301 x 0,070in	
915	5000080736	1	PC	O-Ring Anillo-o	O-ring Joint torique	0,364 x 0,070in	
916	5000080733	1	PC	O-Ring Anillo-o	O-ring Joint torique	0,755 x 0,097in	
917	5000080731	1	PC	O-Ring Anillo-o	O-ring Joint torique	0,468 x 0,078in	

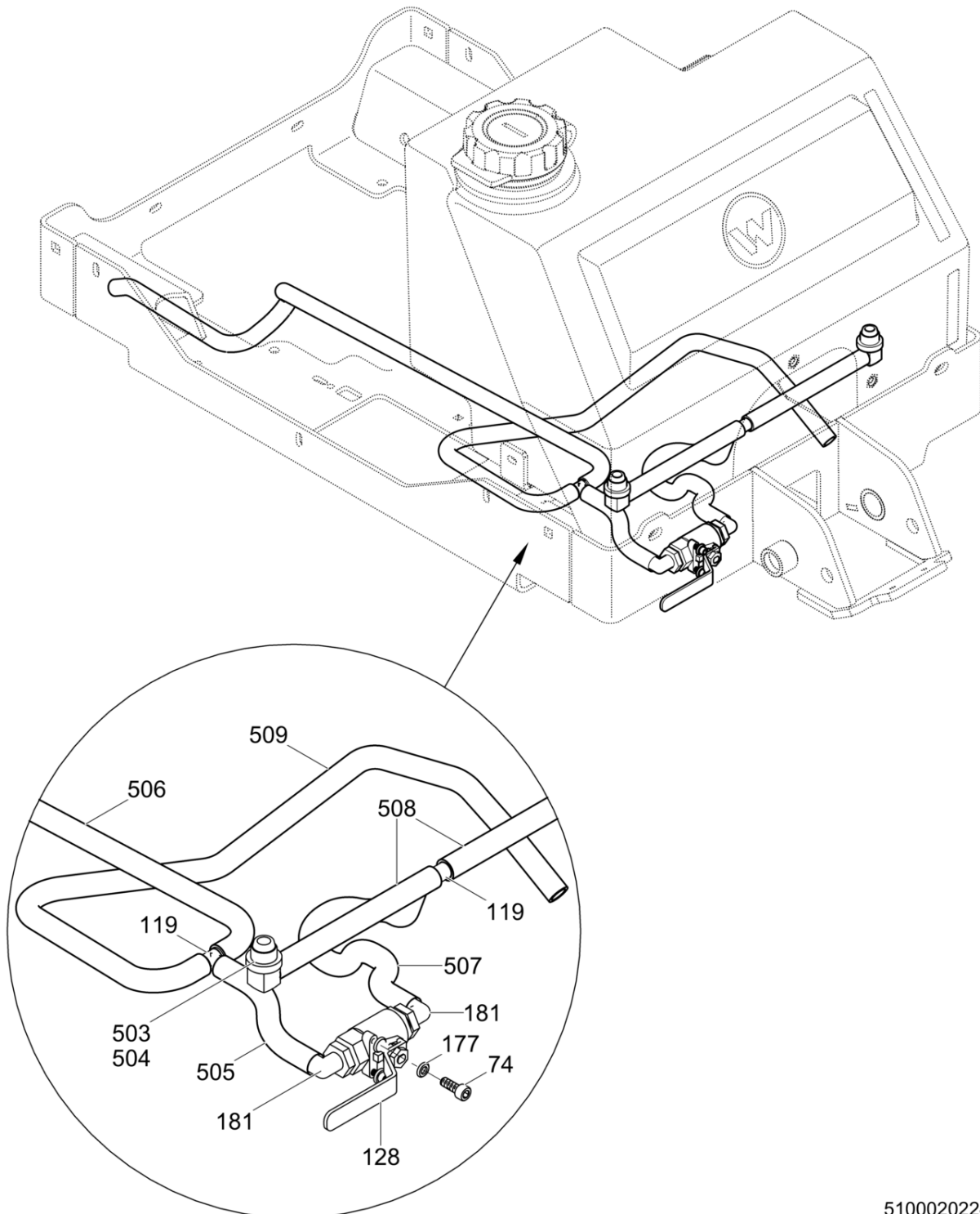

5100020224_02

Pos. Ref.	Artikel Nr. Part No.	Qty.	Unit	Beschreibung Descripcion	Description Description	Abm. Measur.	Norm Standard
						Drehm. Torque	Schmierstoff Sealant
74	5200021951	2	PC	Zylinderschraube Tornillo hueco	Socket head screw Vis à six-pans creux	No.10-24 x 1/2in	
119	5000164157	2	PC	T-Verschraubung Unión forma t	T-fitting Raccord ""t""	1/2in	
128	5000114968	1	PC	Ventil Válvula	Valve Soupape		
177	5000010624	2	PC	Scheibe Arandela	Flat washer Rondelle		
181	5000151121	2	PC	Hydraulikrohrkrümmer Codo hidráulico	Hydraulic elbow fitting Coude hydraulique	1/2in	
503	5100018881	2	PC	Rohrkrümmer Codo	Elbow fitting Raccord coudé	90	
504	5100018882	2	PC	Kabeltülle Boquilla de cable	Grommet Passe-fil		
505	5100018718	1	PC	Wasserschlauch Manguera de agua	Water hose Tuyau d'eau	1/2 ID x 6,0in	
506	5100031210	1	PC	Wasserschlauch Manguera de agua	Water hose Tuyau d'eau	1/2 ID x 29,13in	
507	5100031211	1	PC	Wasserschlauch Manguera de agua	Water hose Tuyau d'eau	1/2 ID x 22,0in	
508	5100018719	1	PC	Wasserschlauch Manguera de agua	Water hose Tuyau d'eau	1/2 ID x 6,5in	
509	5100031212	1	PC	Wasserschlauch Manguera de agua	Water hose Tuyau d'eau	1/2 ID x 9,85in	

Oberer Führungsbügel Kpl.
 Upper handle cpl.
 Manija superior compl.
 Guidon supérieur compl.

RD7YE

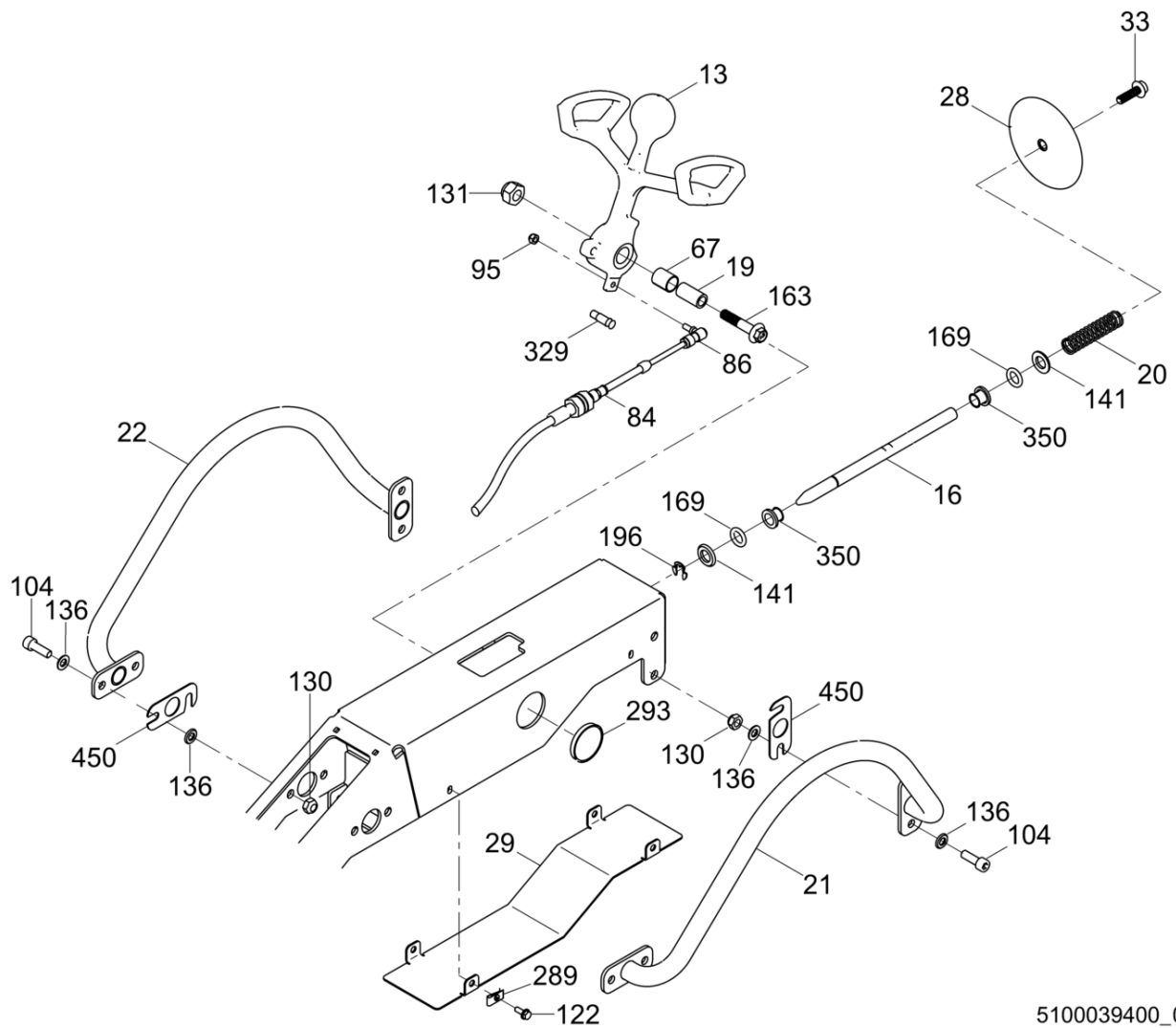

5100039400_01

Pos. Ref.	Artikel Nr. Part No.	Qty.	Unit	Beschreibung Description	Description Description	Abm. Measur.	Norm Standard
						Drehm. Torque	Schmierstoff Sealant
13	5100027394	1	PC	Handgriff Manija	Handle Poignée		
16	5100029378	1	PC	Reisen Kolben Émbolo de viajes	Travel plunger Le piston de déplacement		
19	5100027434	1	PC	Abstandsstück Espaciador	Spacer Entretoise		
20	5200012124	1	PC	Feder Resorte	Spring Ressort		
21	5200021857	1	PC	Rohr Tubo	Tube Tube		
22	5200021858	1	PC	Rohr Tubo	Tube Tube		
28	5200012109	1	PC	Scheibe Disco	Disc Disque		
29	5200013034	1	PC	Platte Placa	Plate Plaque		
33	5200020680	1	PC	Schraube Tornillo	Screw Vis	M10 x 35	
67	5100028347	2	PC	Lager Rodamiento	Bearing Roulement		
84	5100028837	1	PC	Reisekabel Cable de viaje	Travel cable Câble de voyage		
86	5000114114	1	PC	Kugelgelenk Articulación de rótula	Ball joint Accouplement articulé		
95	5000028746	1	PC	Sicherungsmutter Contratuerca	Lock nut Contre-écrou	1/4-28in	
104	5000012382	8	PC	Zylinderschraube Tornillo cilíndrico	Socket head cap screw Vis à tête cylindrique	M10 x 30 83Nm/61ft.lbs	
122	5000028949	4	PC	Schraube Tornillo	Screw Vis	M6 x 16 10Nm/7ft.lbs	
130	5000010365	8	PC	Sicherungsmutter Contratuerca	Lock nut Contre-écrou	M10	DIN980
131	5000010366	1	PC	Sechskantmutter Tuerca hexagonal	Hexagon nut Écrou hexagonal	M12X1.75	DIN985
136	5000010621	16	PC	Scheibe Arandela	Washer Rondelle		
141	5000010618	2	PC	Scheibe Arandela	Flat washer Rondelle	16	ISO7090
163	5100029379	1	PC	Sechskantflanschschraube Tornillo hexagonal de brida	Hexagonal flange head screw Vis hexagonale de bride	M12 x 60 145Nm/107ft.lbs	
169	5200012127	2	PC	O-Ring Anillo-o	O-ring Joint torique		
196	5200015826	1	PC	Sicherungsring Anillo de retención	Retaining ring Anillo de retención		
289	5000088190	4	PC	Klemmutter Sujetador	Clip nut Agrafe	M6	
293	5200015823	2	PC	Kappe Tapa	Cap Capuchon		
329	5100028054	1	PC	Anschlagbolzen Pasador de tope	Stop pin La goupille d'arrêt		
350	5200012126	2	PC	Flansch-Lager Brida-rodamiento	Flange bearing Collerette-roulement		
450	5100021670	4	PC	Ausgleichscheibe Laminita	Shim Cale		

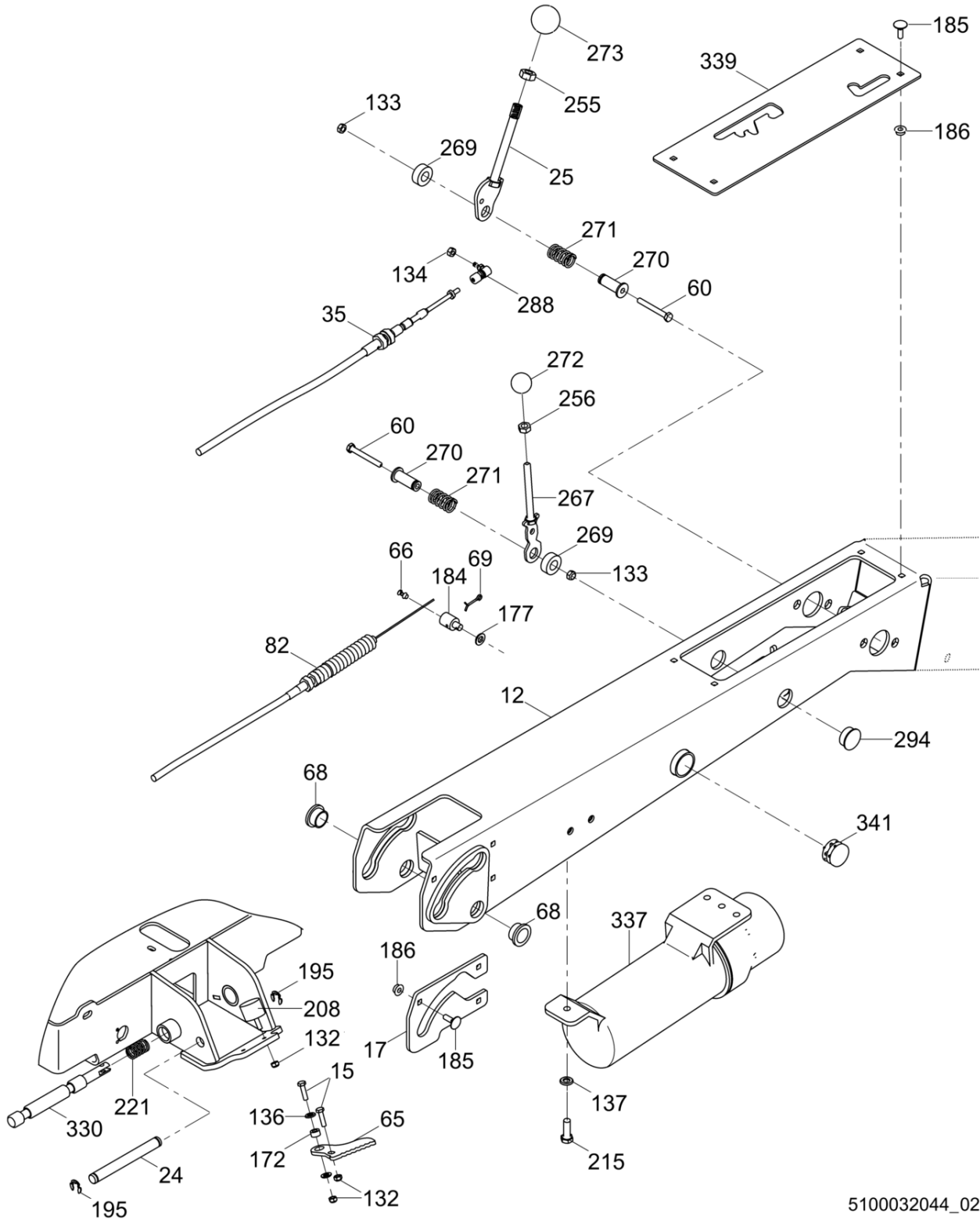

5100032044_02

Pos. Ref.	Artikel Nr. Part No.	Qty.	Unit	Beschreibung Description	Description Description	Abm. Measur.	Norm Standard
						Drehm. Torque	Schmierstoff Sealant
12	5100027393	1	PC	Handgriff Kpl. Manija compl.	Handle cpl. Poignée compl.		
15	5000011456	2	PC	Sechskantschraube Tornillo hexagonal	Hexagonal head cap screw Vis à tête hexagonale	25Nm/18ft.lbs	
24	5200012143	1	PC	Drehteilstift Pivote pasador	Pivot pin Groupille de pivot		
25	5200012184	1	PC	Erregehebel Palanca de excitador	Exciter lever Levier d'excitation		
35	5100028839	1	PC	Erregerleitung Cable exciter	Exciter cable Câble d'excitation		
60	5000011331	2	PC	Sechskantschraube Tornillo hexagonal	Hexagonal head cap screw Vis à tête hexagonale	M6 x 50 10Nm/7ft.lbs	DIN931
65	5200009687	1	PC	Hebel Palanca	Lever Levier		
66	5000156315	1	PC	Gewindestift Tornillo	Setscrew Vis	M6 x 10	
68	5200016935	2	PC	Lager Rodamiento	Bearing Roulement		
69	5000114328	1	PC	Sicherungssplint Clavija hendida	Cotter pin Goupille fendue	1,6 x 16	
82	5100028123	1	PC	Bowdenzug Cable del acelerador	Throttle cable Câble des gaz		
132	5000010367	2	PC	Sechskantmutter Tuerca hexagonal	Hexagon nut Écrou hexagonal	M8	DIN985
133	5000010368	2	PC	Sechskantmutter Tuerca hexagonal	Hexagon nut Écrou hexagonal	M6	DIN985
134	5000028756	1	PC	Sicherungsmutter Contratuerca	Lock nut Contre-écrou	No.10-32	
136	5000010621	2	PC	Scheibe Arandela	Washer Rondelle		
137	5000010622	3	PC	Scheibe Arandela	Flat washer Rondelle		
172	5000182647	1	PC	Abstandsstück Espaciador	Spacer Entretoise		
177	5000010624	1	PC	Scheibe Arandela	Flat washer Rondelle		
184	5200017277	1	PC	Hülse Manguito	Sleeve Douille		
185	5000118955	7	PC	Schloßschraube Tornillo de carruaje	Carriage bolt Boulon brut à tête bombée	M6 x 20	
186	5000164067	7	PC	Sechskantmutter Tuerca hexagonal	Hexagon nut Écrou hexagonal	M6	
195	5200015825	2	PC	Sicherungsring Anillo de retención	Retaining ring Bague d'arrêt		
208	5000032641	2	PC	Gummi-Metall-Puffer Amortiguador	Shockmount Silentbloc		
215	5000011457	3	PC	Sechskantschraube Tornillo hexagonal	Hexagonal head cap screw Vis à tête hexagonale	M8 x 25 31Nm/23ft.lbs	
221	5200017436	1	PC	Feder Resorte	Spring Ressort		
255	5000010883	1	PC	Sechskantmutter Tuerca hexagonal	Hexagon nut Écrou hexagonal		
256	5000010882	1	PC	Sechskantmutter Tuerca hexagonal	Hexagon nut Écrou hexagonal		
267	5200009698	1	PC	Gashebel Palanca de regulador	Throttle lever Levier des gaz		

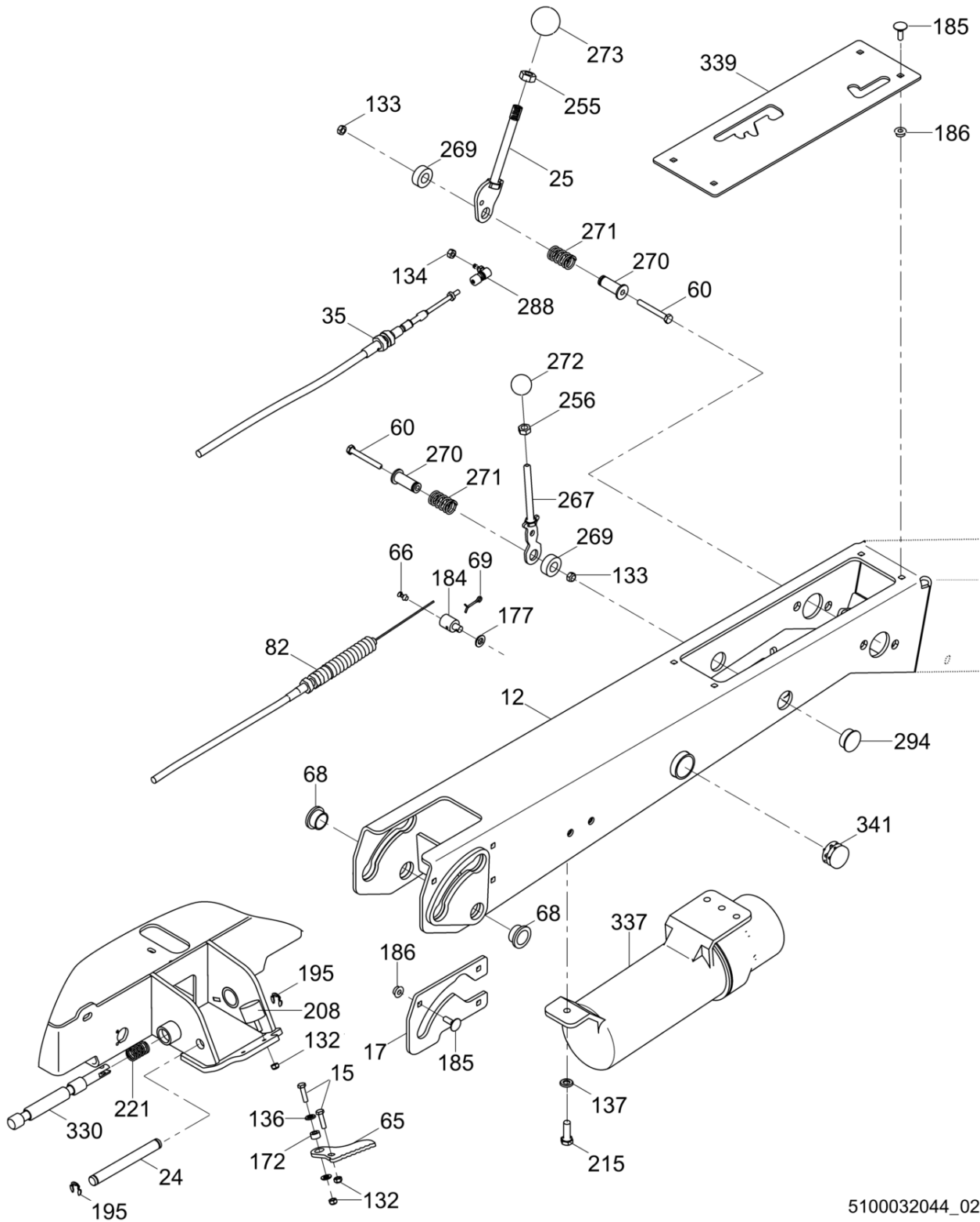

5100032044_02

Pos. Ref.	Artikel Nr. Part No.	Qty.	Unit	Beschreibung Descripcion	Description Description	Abm. Measur.	Norm Standard
						Drehm. Torque	Schmierstoff Sealant
269	5200009620	2	PC	Abstandsstück Espaciador	Spacer Entretoise	0,50 x 1,00 x 0,37	
270	5100017411	2	PC	Abstandsstück Espaciador	Spacer Entretoise		
271	5100017423	2	PC	Feder Resorte	Spring Ressort		
272	5200009623	1	PC	Griff Empuñadura	Knob Poignée		
273	5200024720	1	PC	Griff Empuñadura	Knob Poignée		
288	5200019220	1	PC	Kabel Kugelende Rótula de cable	Cable ball end Extrémité sphérique de câble		
294	5100040313	2	PC	Cap-Press-Fit Cap-press-fit	Cap-press-fit Cap-press-fit		
330	5200012220	1	PC	Abstandstift Pasador distanciadora	Hinge pin Goupille d'écartement		
337	5200008089	1	PC	Handbuchhalter Soporte manual	Manual holder Support de manuel		
339	5100029237	1	PC	Platte Placa	Plate Plaque		
341	5200020639	1	PC	Stopfen Tapón	Plug Bouchon		

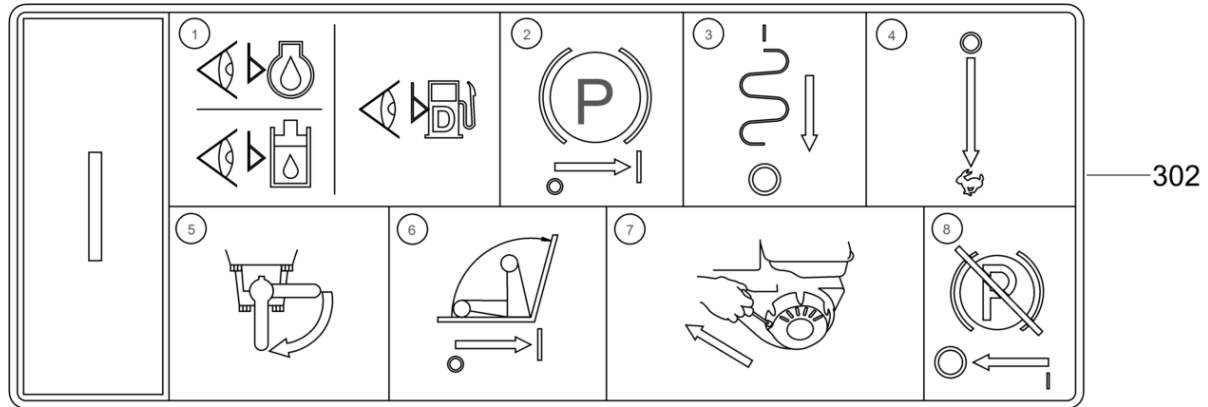

WACKER
NEUSON

U.S.PAT.Nos.: 5586630, 5984425, 6285925,
6382383, 6997648, 7059802, 8328464, D454141,
D461197, D573611 OTHER U.S. AND FOREIGN
PATENTS PENDING
ROLLERS 159114

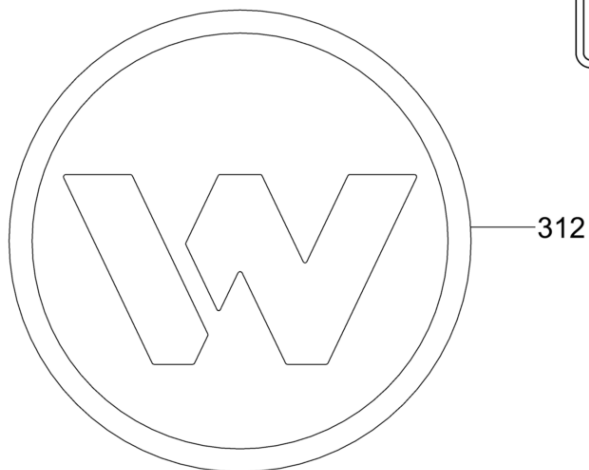

RD7

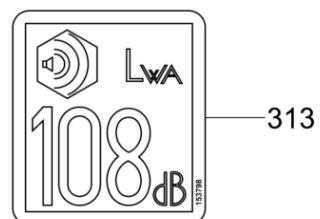

5100032071_01

Pos. Ref.	Artikel Nr. Part No.	Qty.	Unit	Beschreibung Descripcion	Description Description	Abm. Measur.	Norm Standard
						Drehm. Torque	Schmierstoff Sealant
142	5000177771	2	PC	Aufkleber-RD 7 Calcomania-rd 7	Label-rd 7 Autocollant-rd 7		
194	5000222102	2	PC	Aufkleber-Wacker Neuson Logo Calcomanía-wacker neuson logotipo	Label-wacker neuson logo Autocollant-wacker neuson logo	56	
302	5100031183	1	PC	Aufkleberblatt Hoja de calcomanias	Label sheet Feuille d'autocollants		
310	5000159114	1	PC	Aufkleber Calcomania	Label Autocollant		
312	5000222087	1	PC	Aufkleber Symbol Calcomania símbolo	Label symbol Autocollant symbole	120 OD	
313	5000153798	1	PC	Aufkleber-Schalleistungspegel Calcomania-potencia acústica	Label-sound power Autocollant-puissance acoustiq		

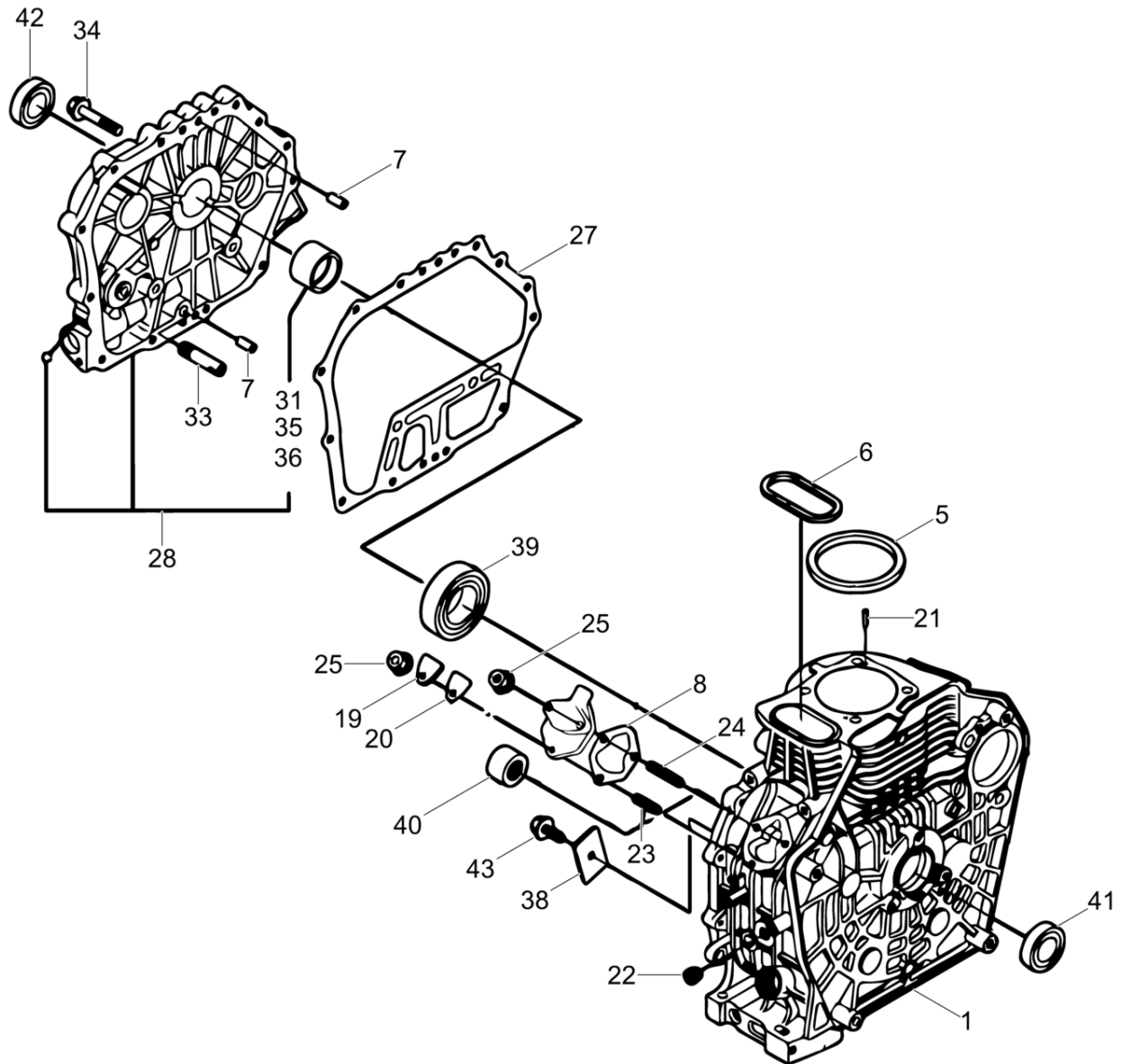

5100031911_01

Pos. Ref.	Artikel Nr. Part No.	Qty.	Unit	Beschreibung Descripcion	Description Description	Abm. Measur.	Norm Standard
						Drehm. Torque	Schmierstoff Sealant
1	5100029839	1	PC	Kurbelgehäuse Cárter	Crankcase Carter		
5	5100030491	1	PC	Zylinderkopfdichtung Junta de culata del cilindro	Cylinder head gasket Joint de culasse de cylindre		
6	5100031772	1	PC	O-Ring Anillo-o	O-ring Joint torique		
7	5000213226	2	PC	Stift Espiga	Pin Goupille		
8	5000210485	1	PC	Dichtung Junta	Gasket Joint		
19	5000210486	1	PC	Deckel Tapa	Cover Couvercle		
20	5000073612	1	PC	Dichtung Junta	Gasket Joint		
21	5000119715	2	PC	Stift Espiga	Pin Goupille	4x8	
22	5000217932	1	PC	Schraubverschluss Cierre roscada	Screw locking Fermeture de vissage		
23	5000119720	1	PC	Gewindebolzen Perno roscado	Threaded bolt Boulon fileté	M6 x 18	
24	5000119721	2	PC	Bolzen Perno	Bolt Boulon	M6 x 22	
25	5000119722	3	PC	Mutter Tuerca	Nut Erou	M6	
27	5100031773	1	PC	Kurbelgehäusedichtung Junta del cárter	Crankcase gasket Joint de carter		
28	5100030140	1	PC	Kurbelgehäusedeckel Tapa del cárter	Crankcase cover Couvercle de carter		
31	5100031774	1	PC	Lager Rodamiento	Bearing Roulement		
33	5000210490	1	PC	Leitung Cable eléctrico	Electric wire Fil ressortant		
34	5000085522	16	PC	Schraube Tornillo	Screw Vis	M8 x 35 25Nm/18ft.lbs	
35	5100031775	1	PC	Lager Rodamiento	Bearing Roulement	0,25	
36	5100031776	1	PC	Lager Rodamiento	Bearing Roulement	0,50	
38	5000119726	1	PC	Halter Soporte	Bracket Support		
39	5100031777	1	PC	Lager Rodamiento	Bearing Roulement		
40	5100031778	1	PC	Zyl.-Rollenlager Rodamiento cilíndricos	Cylindrical roller bearing Roulement à rouleaux		
41	5100031779	1	PC	Wellendichtring Empaque de aceite	Oil seal Joint d'huile		
42	5100031779	1	PC	Wellendichtring Empaque de aceite	Oil seal Joint d'huile		
43	5000073622	1	PC	Schraube Tornillo	Screw Vis	M8 x 12 25Nm/18ft.lbs	

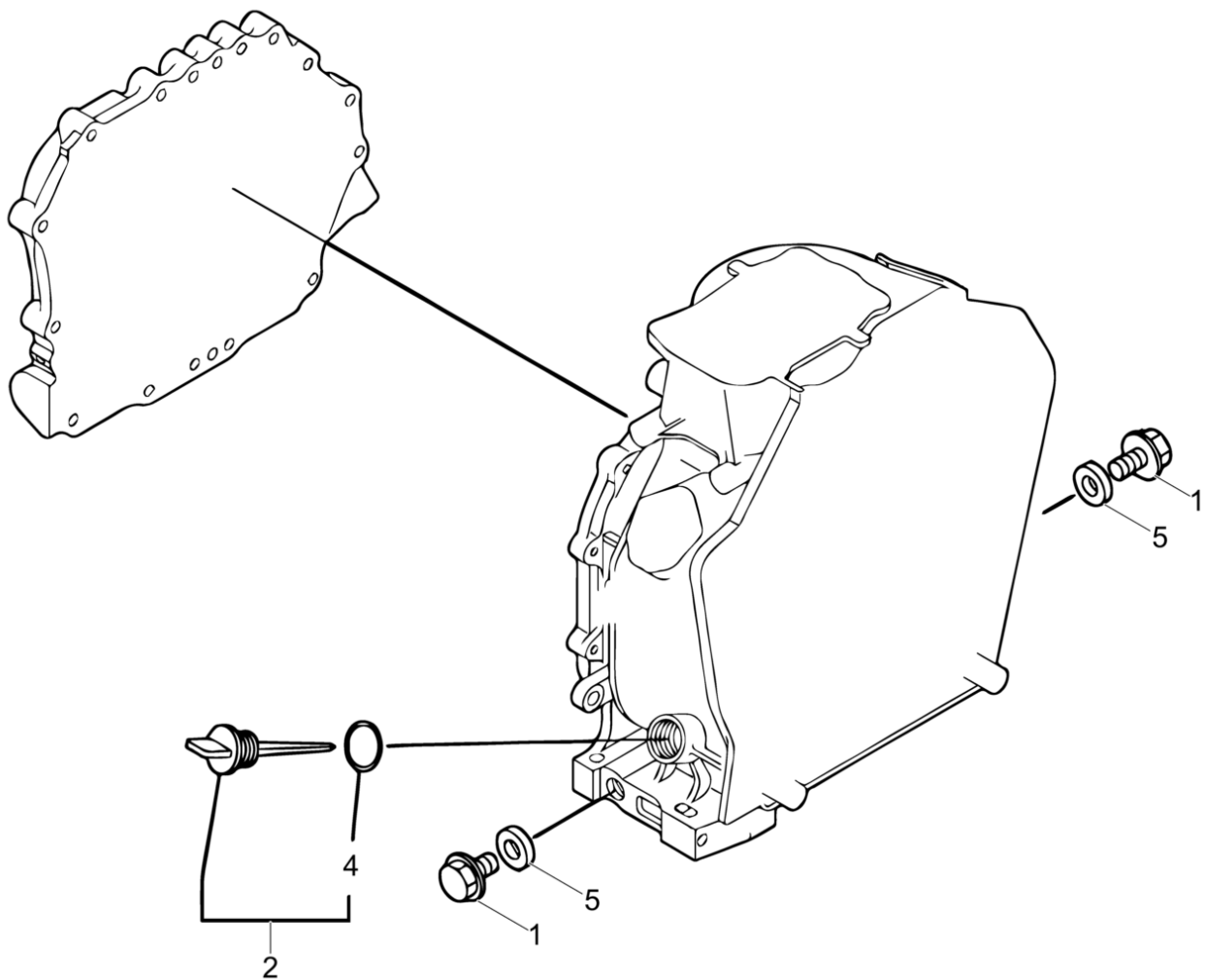

5100031912_01

Pos. Ref.	Artikel Nr. Part No.	Qty.	Unit	Beschreibung Descripcion	Description Description	Abm. Measur.	Norm Standard
						Drehm. Torque	Schmierstoff Sealant
1	5000213227	2	PC	Verschlusschraube Tapón roscado	Screw plug Vis de fermeture		
2	5000150327	1	PC	Ölmeßstab Kpl. Varilla de sondear aceite cpl.	Oil dip stick cpl. Jauge de niveau d'huile cpl.		
4	5000073609	1	PC	O-Ring Anillo-o	O-ring Joint torique	18 x 2,2	
5	5000073608	2	PC	Scheibe Arandela	Washer Rondelle		

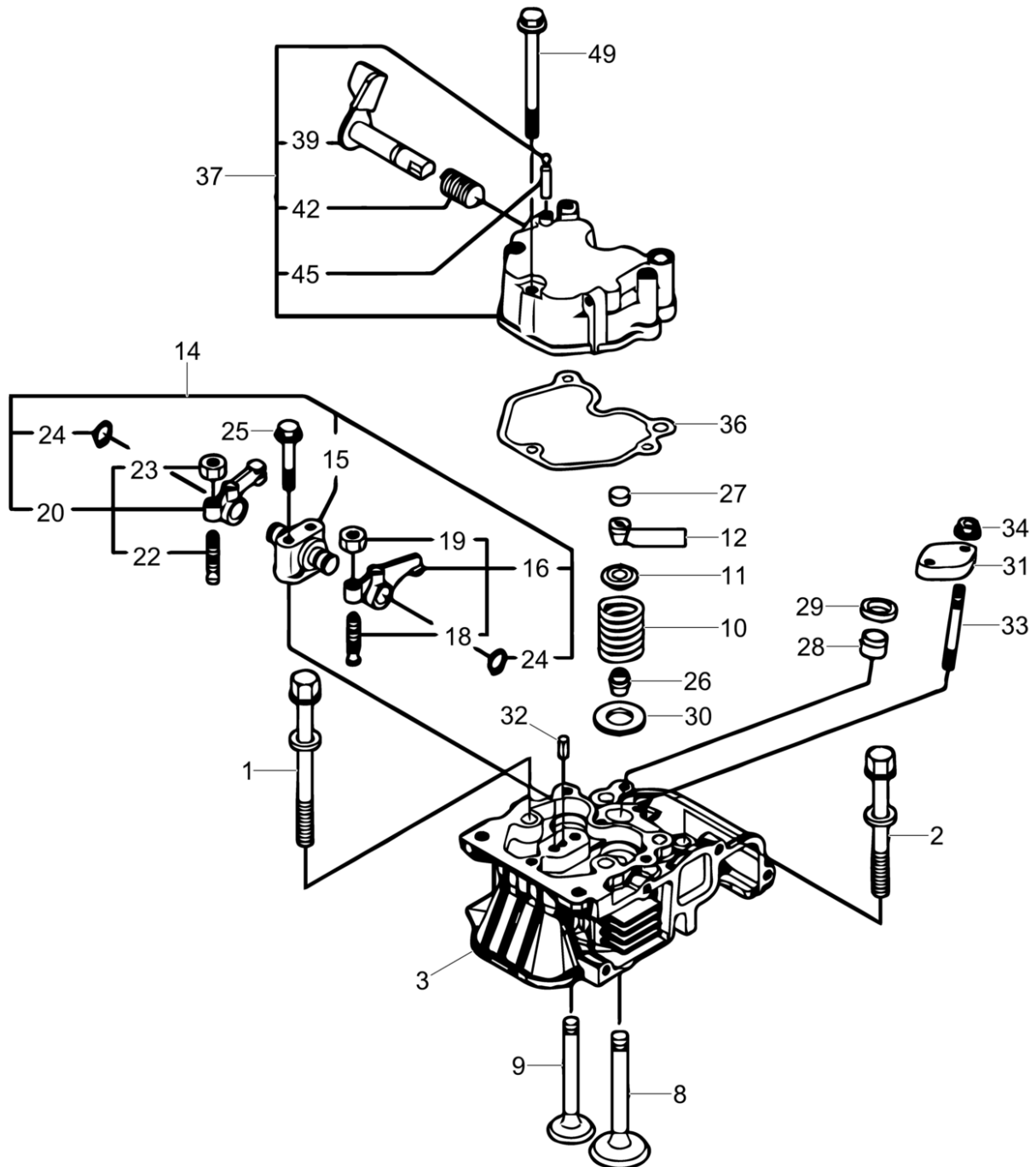

5100031913_01

Pos. Ref.	Artikel Nr. Part No.	Qty.	Unit	Beschreibung Descripción	Description Description	Abm. Measur.	Norm Standard
						Drehm. Torque	Schmierstoff Sealant
1	5100031834	2	PC	Bolzen Perno	Bolt Boulon		
2	5100031835	2	PC	Bolzen Perno	Bolt Boulon		
3	5100031836	1	PC	Zylinderkopf Kpl. Culata del cilindro compl.	Cylinder head cpl. Culasse de cylindre compl.		
8	5100031837	1	PC	Einlassventil Válvula de admisión	Intake valve Soupape d'admission		
9	5100031838	1	PC	Auslaßventil Válvula de escape	Exhaust valve Soupape d'échappement		
10	5100031839	2	PC	Ventilfeder Resorte de válvula	Valve spring Ressort de soupape		
11	5100031840	2	PC	Halter Retenedor	Retainer Arrêtoir		
12	5100031841	2	PC	Sicherungs Hendida	Cotter Goupille		
14	5100031842	1	PC	Konsole Soporte	Bracket Support		
15	5100031843	1	PC	Konsole Soporte	Bracket Support		
16	5100031844	1	PC	Kipphebel Balancín	Rocker arm Culbuteur		
18	5000096764	1	PC	Einstellschraube Regulador	Control Commande		
19	5000119736	1	PC	Sicherungsmutter Contratuerca	Locknut Contre-écrou		
20	5100031845	1	PC	Kipphebel Balancín	Rocker arm Culbuteur		
22	5000096764	1	PC	Einstellschraube Regulador	Control Commande		
23	5000119736	1	PC	Sicherungsmutter Contratuerca	Locknut Contre-écrou		
24	5100030492	2	PC	Sicherungsring Anillo de retención	Retaining ring Bague d'arrêt	1,5	
25	5100031846	2	PC	Bolzen Perno	Bolt Boulon		
26	5100030148	2	PC	Ventildichtung Empaque	Seal Joint		
27	5100031847	2	PC	Ventilkappe Casquete de válvula	Valve cap Joint de soupape		
28	5000217896	1	PC	Dichtung Junta de estanqueidad	Gasket Garniture		
29	5000213210	1	PC	Scheibe Disco	Washer Rondelle		
30	5100030150	2	PC	Scheibe Arandela	Washer Rondelle		
31	5000217849	1	PC	Halter Soporte	Bracket Équerre		
32	5000073641	1	PC	Stift Espiga	Pin Goupille	4x 8	
33	5000073630	2	PC	Gewindebolzen Perno prisionero	Stud Boulon	M 6x 55	
34	5000119722	2	PC	Mutter Tuerca	Nut Ecrou	M6	
36	5100031848	1	PC	Zylinderkopfdichtung Junta de culata del cilindro	Cylinder head gasket Joint de culasse de cylindre		

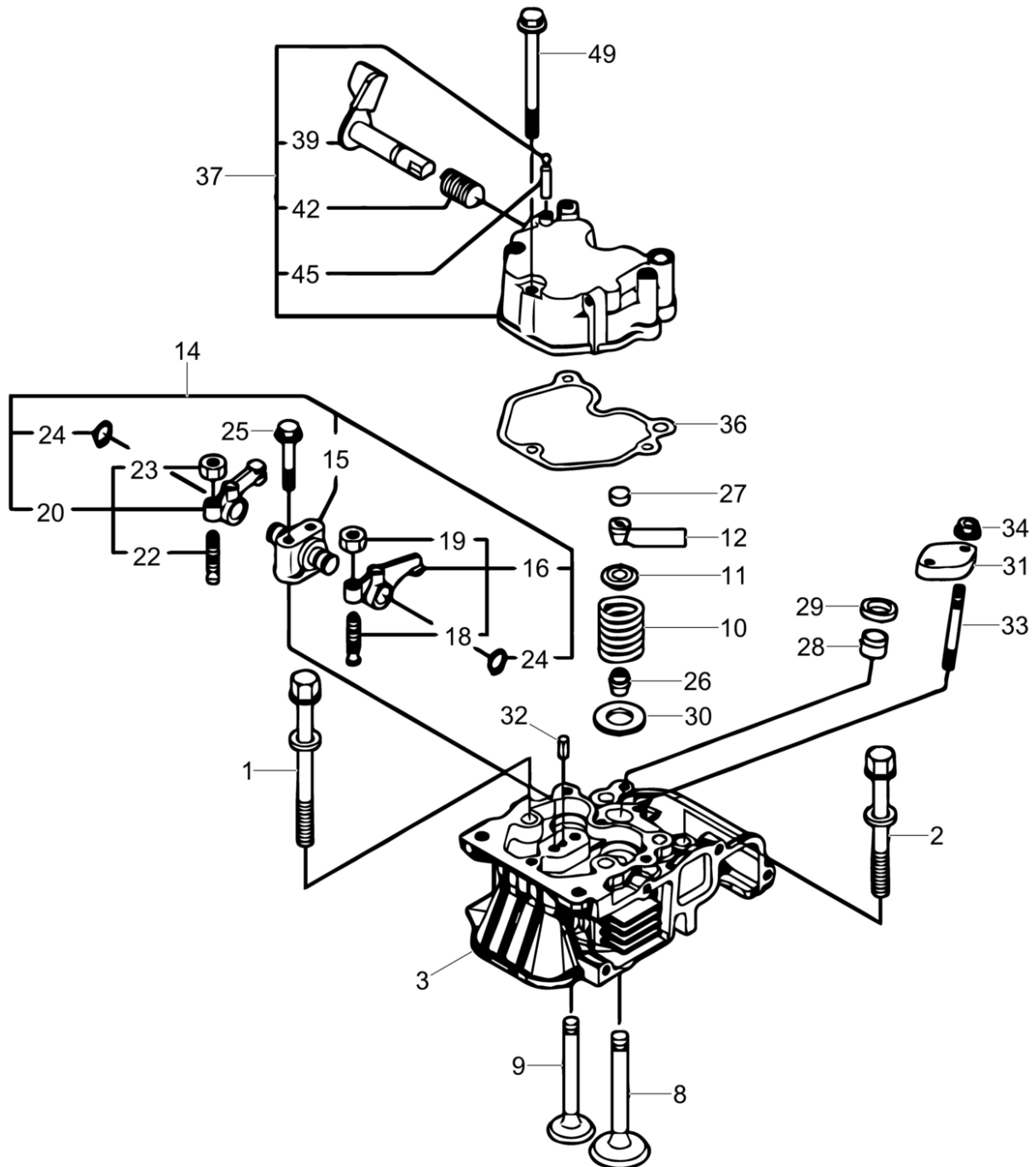

5100031913_01

Pos. Ref.	Artikel Nr. Part No.	Qty.	Unit	Beschreibung Description	Description Description	Abm. Measur.	Norm Standard
						Drehm. Torque	Schmierstoff Sealant
37	5100031849	1	PC	Zylinderkopfdeckel Kpl. Tapa compl.-culata	Cylinder head cover assembly Couvercle compl.-culasse		
39	5000217837	1	PC	Welle Kpl. Árbol cpl.	Shaft cpl. Arbre cpl.		
42	5000217898	1	PC	Feder Resorte	Spring Ressort		
45	5000073648	1	PC	Stift Espiga	Pin Goupille	3x16	
49	5100031850	3	PC	Bolzen Perno	Bolt Boulon	M6 x 65	

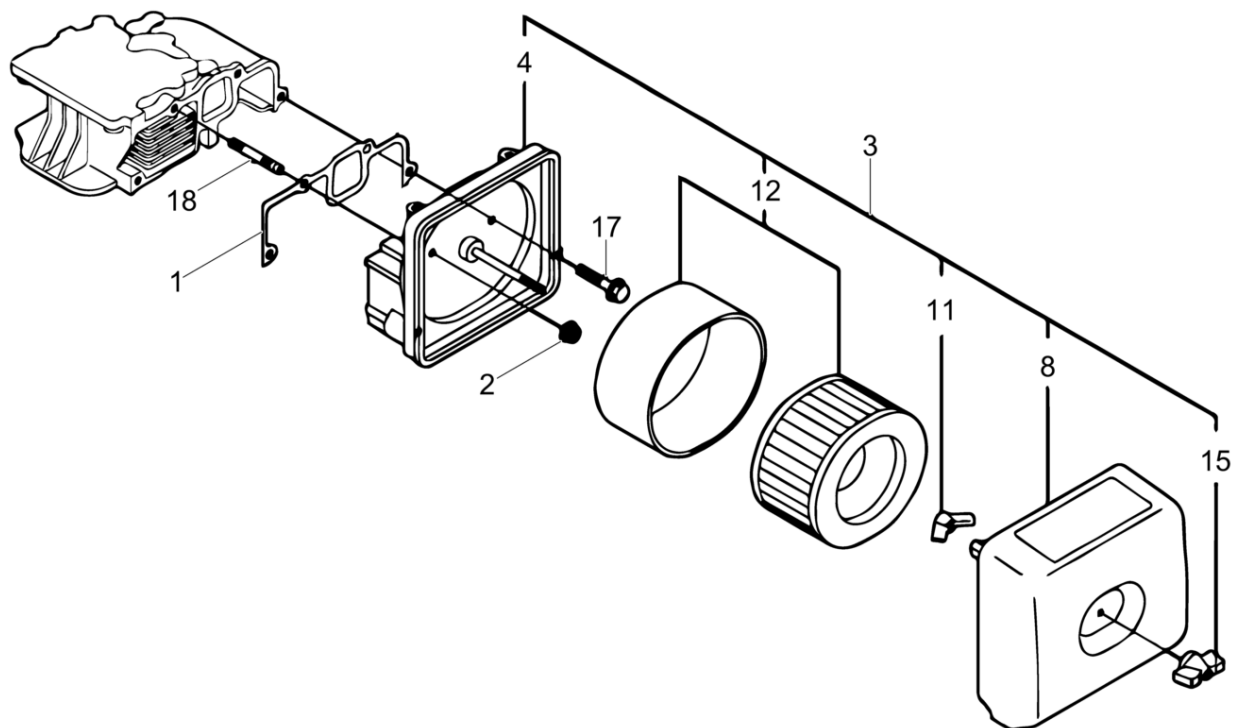

5100031914_01

Pos. Ref.	Artikel Nr. Part No.	Qty.	Unit	Beschreibung Descripcion	Description Description	Abm. Measur.	Norm Standard
						Drehm. Torque	Schmierstoff Sealant
1	5100031811	1	PC	Luftfilterdichtung Junta filtro de aire	Air filter seal Joint filtre à air		
2	5000213232	3	PC	Flanschmutter Tuerca de brida	Flange nut Écrou à bride		
3	5100031812	1	PC	Luftfilter Filtro del aire	Air cleaner Filtre à air		
4	5100030151	1	PC	Gehäuse Cuerpo	Body Corps		
8	5100031813	1	PC	Luftfilterdeckel Tapa filtro de aire	Air filter cover Couvercle filtre à air		
11	5000217853	1	PC	Flügelmutter Tuerca mariposa	Wing nut Ecrou papillon		
12	5000217854	1	PC	Luftfiltereinsatz Inserto para filtro de aire	Air filter insert Garniture filtre à air		
15	5000217855	1	PC	Flügelmutter Tuerca mariposa	Wing nut Ecrou papillon		
17	5200020114	1	PC	Bolzen Perno	Bolt Boulon	M6 x 40	
18	5100031814	3	PC	Gewindebolzen Perno prisionero	Stud Boulon	M6 x 35	

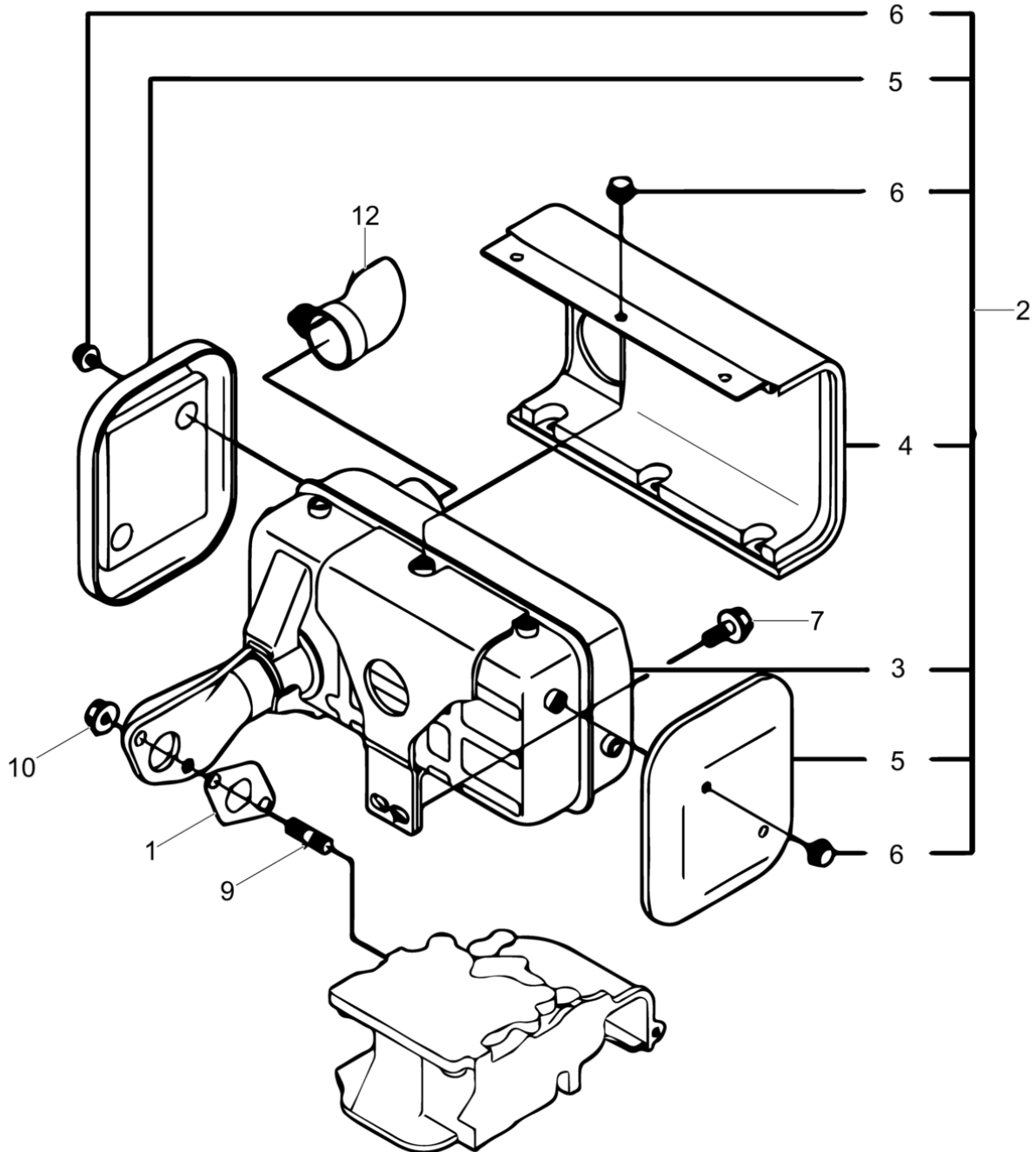

5100031915_01

Pos. Ref.	Artikel Nr. Part No.	Qty.	Unit	Beschreibung Descripcion	Description Description	Abm. Measuram.	Norm Standard
						Drehm. Torque	Schmierstoff Sealant
1	5100031815	1	PC	Dichtung Junta	Gasket Joint		
2	5100030202	1	PC	Auspufftopf Silenciador	Muffler Pot d'échappement		
3	5100030494	1	PC	Auspufftopf Silenciador	Muffler Pot d'échappement		
4	5100031816	1	PC	Deckel Tapa	Cover Couvercle		
5	5100031817	2	PC	Deckel Tapa	Cover Couvercle		
6	5100031818	10	PC	Bolzen Perno	Bolt Boulon	M6	
7	5000153980	2	PC	Bolzen M 8X20, Plated Perno	Bolt Boulon	M8 x 20	
9	5000073640	2	PC	Gewindebolzen Perno prisionero	Stud Boulon	M 8x 18	
10	5000153995	2	PC	Mutter Tuerca	Nut Ecrou		
12	5100030156	1	PC	Aufpuffleitblech Deflector de escape	Exhaust baffle Déflecteur d'échappement		

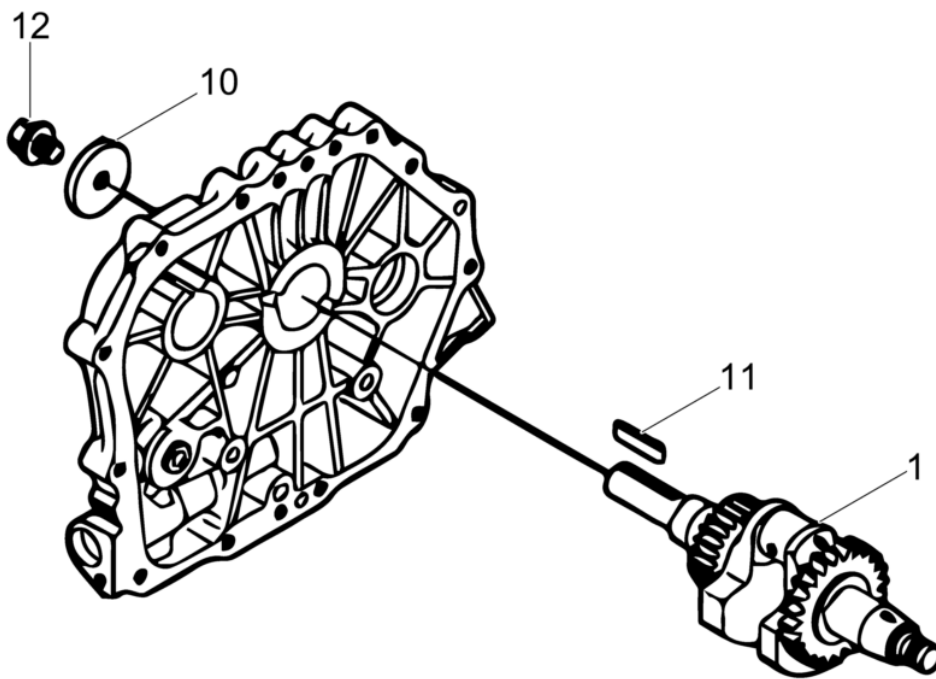

5100031916_01

Pos. Ref.	Artikel Nr. Part No.	Qty.	Unit	Beschreibung Descripcion	Description Description	Abm. Measuram.	Norm Standard
						Drehm. Torque	Schmierstoff Sealant
1	5100031819	1	PC	Kurbelwelle Kpl. Cigüeñal compl.	Crankshaft cpl. Vilebrequin compl.		
10	5000073674	1	PC	Scheibe Arandela	Washer Rondelle		
11	5000210518	1	PC	Passfeder Chaveta	Fitting key Clavette	7 x 36	
12	5000153980	1	PC	Bolzen M 8X20, Plated Perno	Bolt Boulon	M8 x 20	

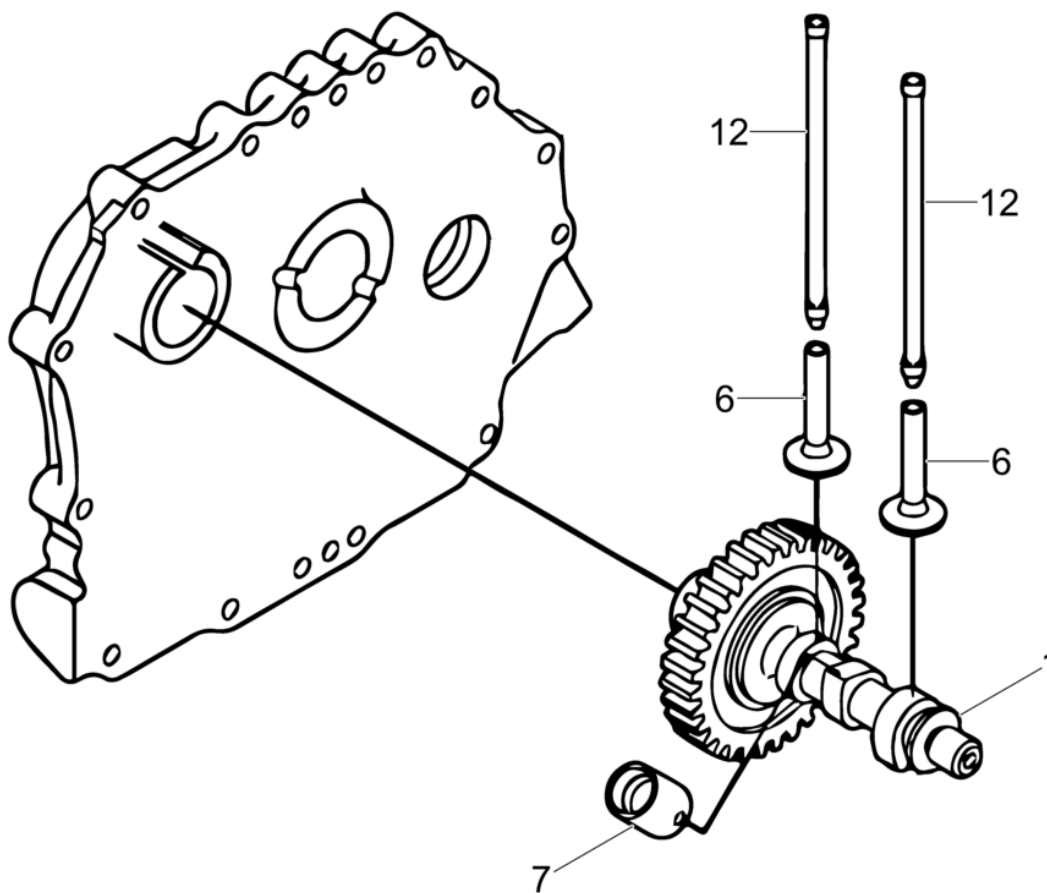

5100031917_01

Pos. Ref.	Artikel Nr. Part No.	Qty.	Unit	Beschreibung Descripcion	Description Description	Abm. Measurem.	Norm Standard
						Drehm. Torque	Schmierstoff Sealant
1	5100031870	1	PC	Nockenwelle Kpl. Arbol de levas compl.	Camshaft cpl. Arbre à cames compl.		
6	5100031871	2	PC	Stößel Alzaválvulas	Tappet Poussoir		
7	5000217857	1	PC	Stössel Alzaválvulas	Tappet Poussoir		
12	5100031872	2	PC	Pleuel Biela	Connecting rod Bielle		

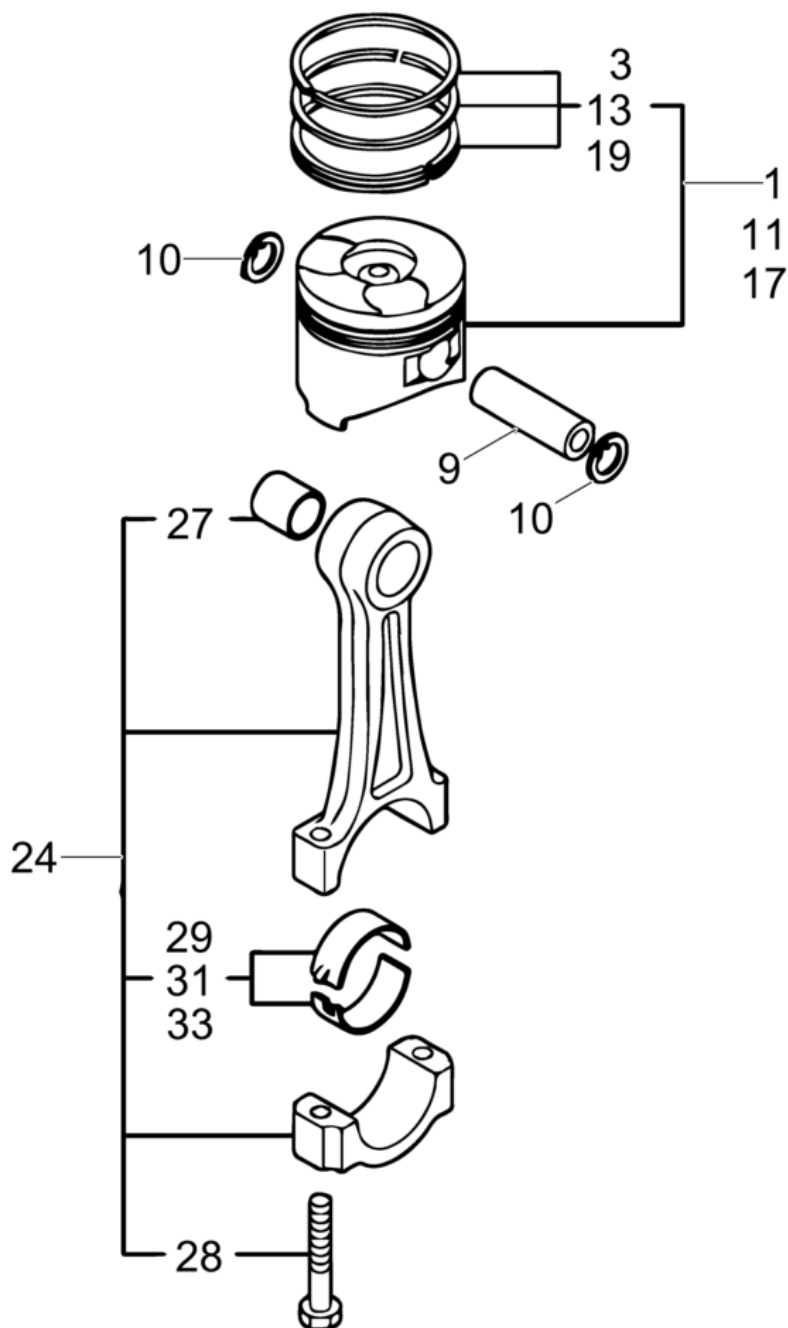

5100031918_01

Pos. Ref.	Artikel Nr. Part No.	Qty.	Unit	Beschreibung Descripción	Description Description	Abm. Measur.	Norm Standard
						Drehm. Torque	Schmierstoff Sealant
1	5100031873	1	PC	Satz-Kolben Mit Kolbenringen Juego-pistón con aros	Piston w/ring set Jeu-piston avec segments		
3	5100031874	1	PC	Kolbenringsatz Juego de anillos	Piston ring set Jeu de segments		
9	5000169141	1	PC	Kolbenbolzen Pasador de pistón	Piston pin Axe de piston		
10	5100030561	2	PC	Sicherungsring Anillo fijador	Lock ring Circlips		
11	5100031875	1	PC	Kolbenringsatz Juego de anillos	Piston ring set Jeu de segments	+0,25	
13	5100031876	1	PC	Kolbenringsatz Juego de anillos	Piston ring set Jeu de segments	0,25	
17	5100031877	1	PC	Kolbenringsatz Juego de anillos	Piston ring set Jeu de segments	+0,5	
19	5100031878	1	PC	Kolbenringsatz Juego de anillos	Piston ring set Jeu de segments	0,25	
24	5100030562	1	PC	Pleuel Kpl. Biela compl.	Connecting rod cpl. Bielle compl.		
27	5100030159	1	PC	Lager Rodamiento	Bearing Roulement		
28	5100031874	2	PC	Kolbenringsatz Juego de anillos	Piston ring set Jeu de segments		
29	5100031880	1	PC	Lager Rodamiento	Bearing Roulement		
31	5100031881	1	PC	Lager Rodamiento	Bearing Roulement	0,25	
33	5100031882	1	PC	Lager Rodamiento	Bearing Roulement	0,50	

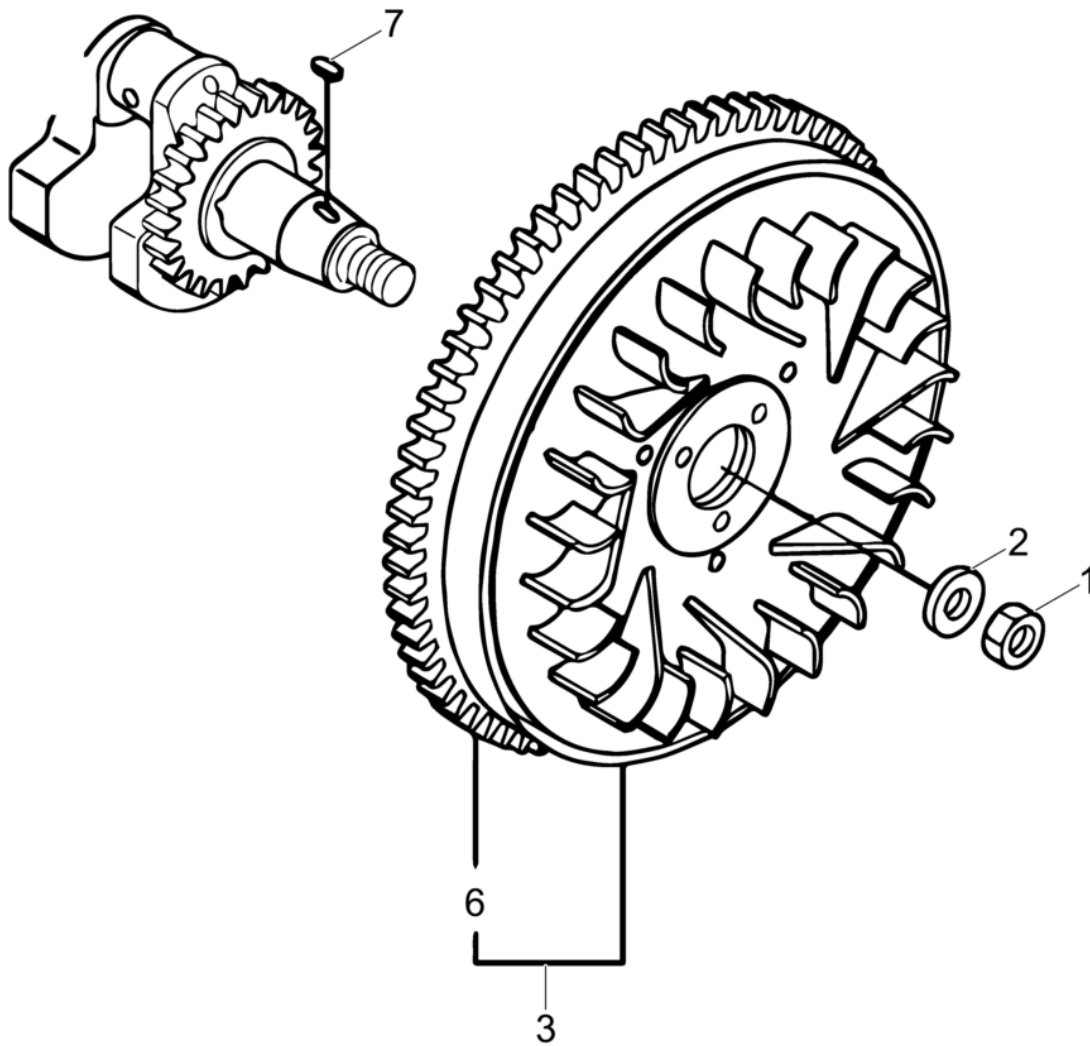

5100031919_01

Pos. Ref.	Artikel Nr. Part No.	Qty.	Unit	Beschreibung Descripcion	Description Description	Abm. Measur.	Norm Standard
						Drehm. Torque	Schmierstoff Sealant
1	5100030157	1	PC	Mutter Tuerca	Nut Écrou		
2	5100030158	1	PC	Scheibe Arandela	Washer Rondelle		
3	5100031883	1	PC	Schwungrad Kpl. Volante compl.	Flywheel cpl. Volant compl.		
6	5100031884	1	PC	Getriebegehäusering Tapa de caja de anillo	Gear ring Couvercle de la boîte de annea		
7	5100031885	1	PC	Passfeder Llave	Key Clé	4 x 14	

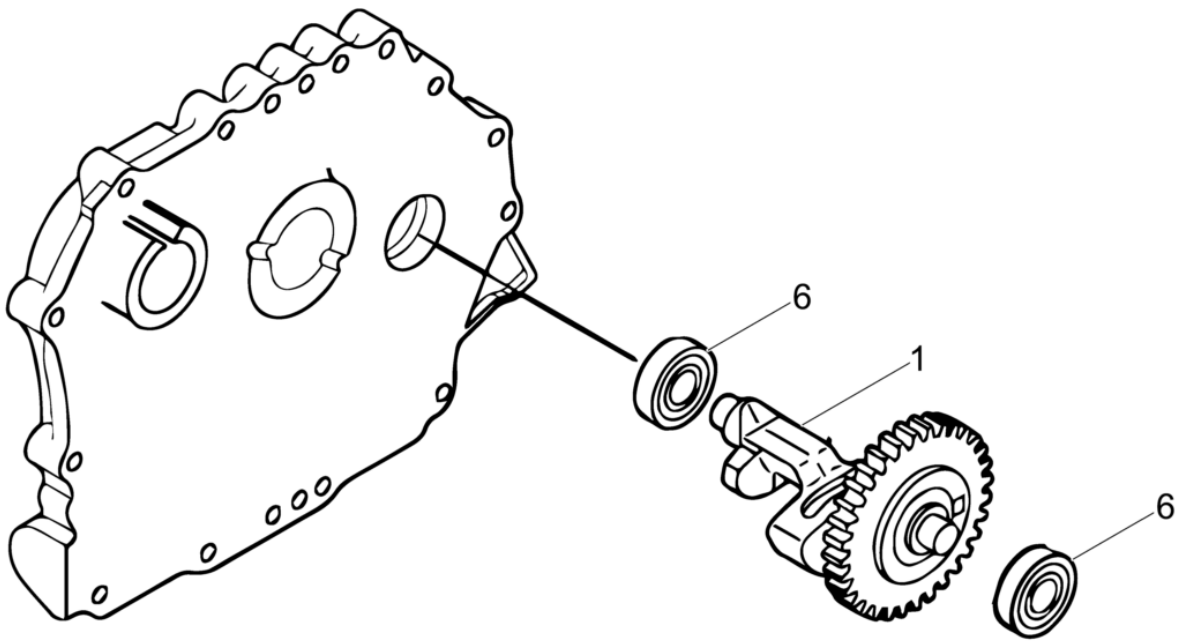

5100031930_01

Pos. Ref.	Artikel Nr. Part No.	Qty.	Unit	Beschreibung Descripcion	Description Description	Abm. Measur.	Norm Standard
						Drehm. Torque	Schmierstoff Sealant
1	5100031886	1	PC	Erregerwelle Eje del excitador	Balance shaft Arbre de l'excitatrice		
6	5100031887	2	PC	Kugellager Rodamiento de bolas	Ball bearing Roulement à billes		

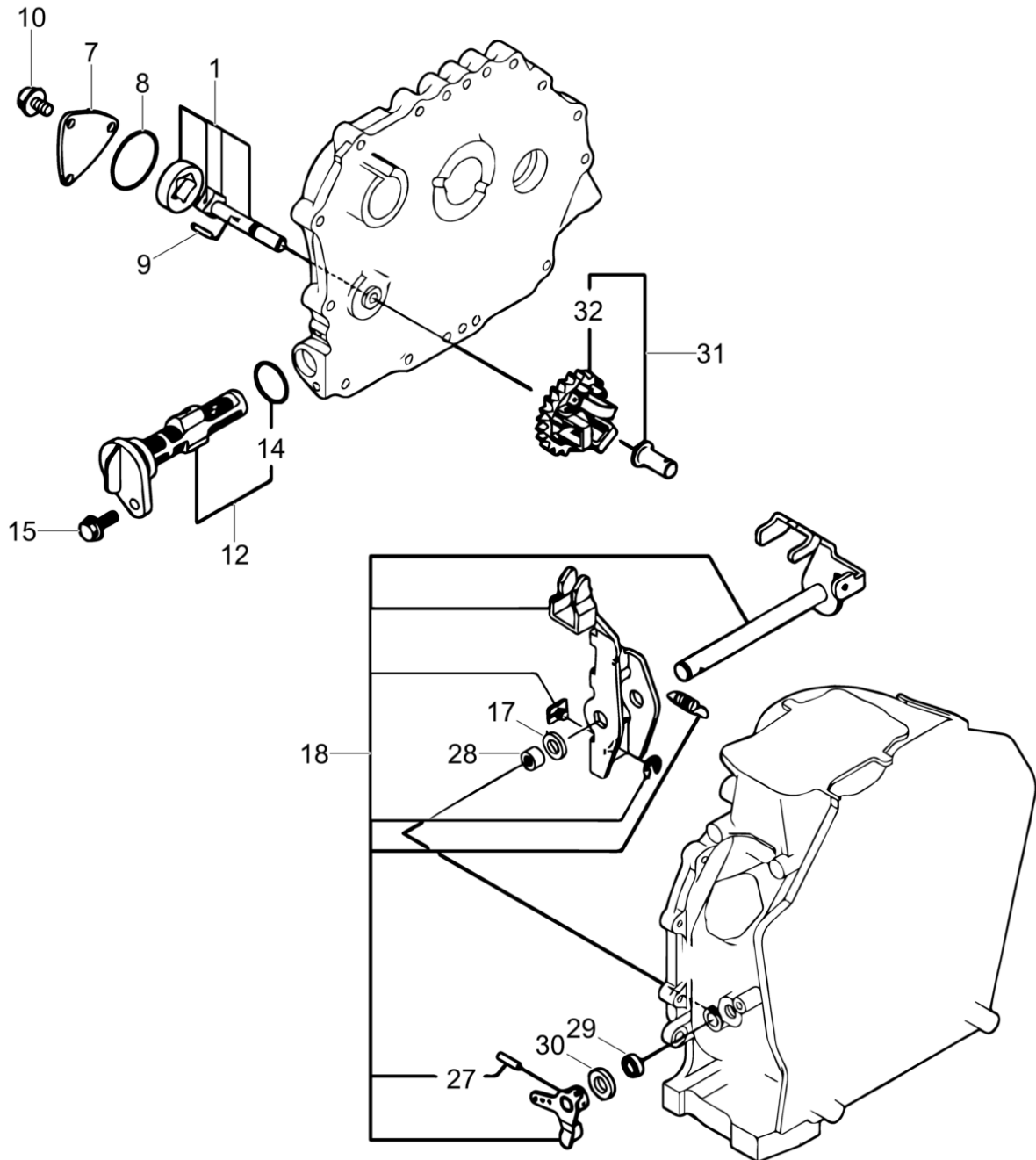

5100031931_01

Pos. Ref.	Artikel Nr. Part No.	Qty.	Unit	Beschreibung Descripcion	Description Description	Abm. Measur.	Norm Standard
						Drehm. Torque	Schmierstoff Sealant
1	5100031888	1	PC	Ölpumpe Kpl. Bomba de aceite compl.	Oil pump cpl. Pompe à huile compl.		
7	5000210520	1	PC	Deckel Tapa	Cover Couvercle		
8	5000210618	1	PC	O-Ring Anillo-o	O-ring Joint torique		
9	5000073648	1	PC	Stift Espiga	Pin Goupille	3x16	
10	5000119897	3	PC	Schraube Tornillo	Screw Vis	M6x12	
12	5000096745	1	PC	Ölfilter Filtro de aceite	Oil filter Filtre d'huile		
14	5000073693	1	PC	O-Ring Anillo-o	O-ring Joint torique	22,4 x 1,8	
15	5000073659	1	PC	Schraube Tornillo	Screw Vis	M6 x 16 10Nm/7ft.lbs	
17	5000210527	1	PC	Dichtung Junta	Gasket Joint		
18	5100031889	1	PC	Reglerhebel Kpl. Palanca de regulador compl.	Governor lever cpl. Lever régulateur compl.		
27	5000119854	1	PC	Stift Espiga	Pin Goupille	3x20	
28	5000119867	2	PC	Lager Rodamiento	Bearing Roulement		
29	5000210526	1	PC	Öldichtung Junta de aceite	Oil seal Joint d'huile		
30	5000087375	1	PC	Scheibe Arandela	Washer Rondelle		
31	5000217943	1	PC	Drehzahlregler Kpl. Controlador de velocidad cpl.	Speed control module cpl. Régulateur de vitesse cpl.		
32	5000217882	1	PC	Reglergewicht Peso	Weight Poids		

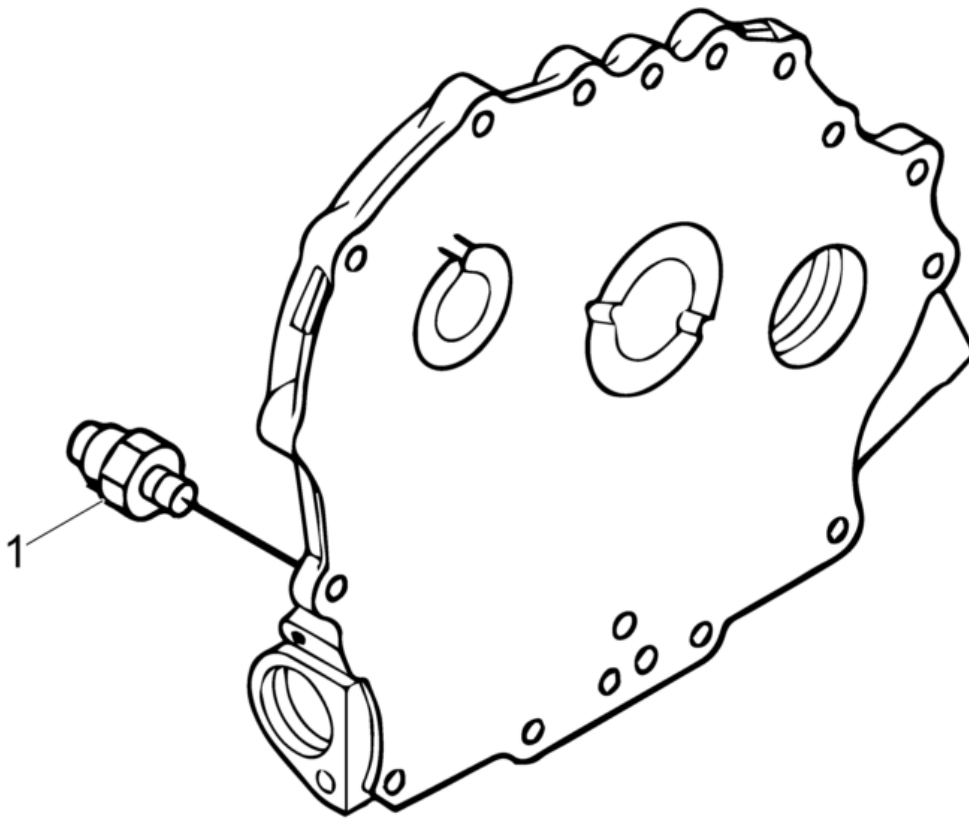

5100031932_01

RD7YE**Öldrucksender
Oil pressure switch
Transmisor de presión de aceite
Transmetteur à pression d'huile**

Pos. Ref.	Artikel Nr. Part No.	Qty.	Unit	Beschreibung Descripción	Description Description	Abm. Measur.	Norm Standard
						Drehm. Torque	Schmierstoff Sealant
1	5100031890	1	PC	Ölschalter Interruptor en aceite	Oil switch Interrupteur à huile		



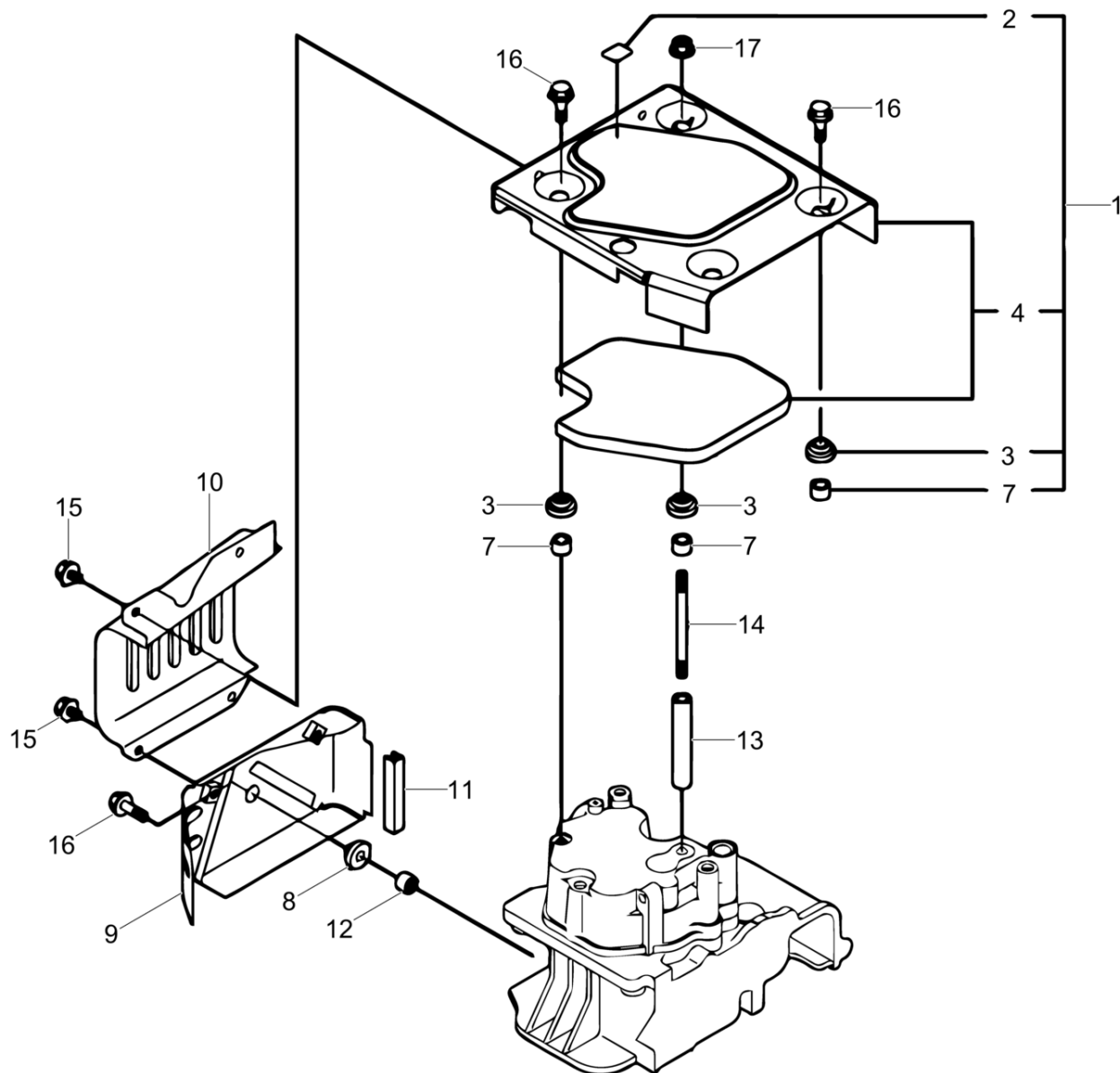

5100031933_01

Pos. Ref.	Artikel Nr. Part No.	Qty.	Unit	Beschreibung Descripcion	Description Description	Abm. Measur.	Norm Standard
						Drehm. Torque	Schmierstoff Sealant
1	5100030163	1	PC	Deckel Tapa	Cover Couvercle		
2	5100031891	1	PC	Aufkleber Calcomania	Label Autocollant		
3	5000217901	4	PC	Tülle Ojal	Grommet Passe-fil		
4	5100030565	1	PC	Deckel Tapa	Cover Couvercle		
7	5000210540	4	PC	Hülse Collar	Sleeve Douille		
8	5000217901	1	PC	Tülle Ojal	Grommet Passe-fil		
9	5100030161	1	PC	Deckel Tapa	Cover Couvercle		
10	5100030162	1	PC	Deckel Tapa	Cover Couvercle		
11	5000217920	1	PC	Dichtung Junta de estanqueidad	Gasket Garniture		
12	5000210540	1	PC	Hülse Collar	Sleeve Douille		
13	5100030164	1	PC	Schieber Registro	Damper Registre		
14	5100031892	1	PC	Zylinderkopfgewindebolzen Perno prisionero de la culatadel cilindro	Cylinder head stud Goujon de culasse		
15	5000119905	4	PC	Schloßschraube Tornillo	Mushroom head bolt Vis	M 6x 8	
16	5000150361	4	PC	Flanschschraube Tornillo de brida	Flange screw Vis de bride	M6 x 20	
17	5000119722	1	PC	Mutter Tuerca	Nut Ecrou	M6	

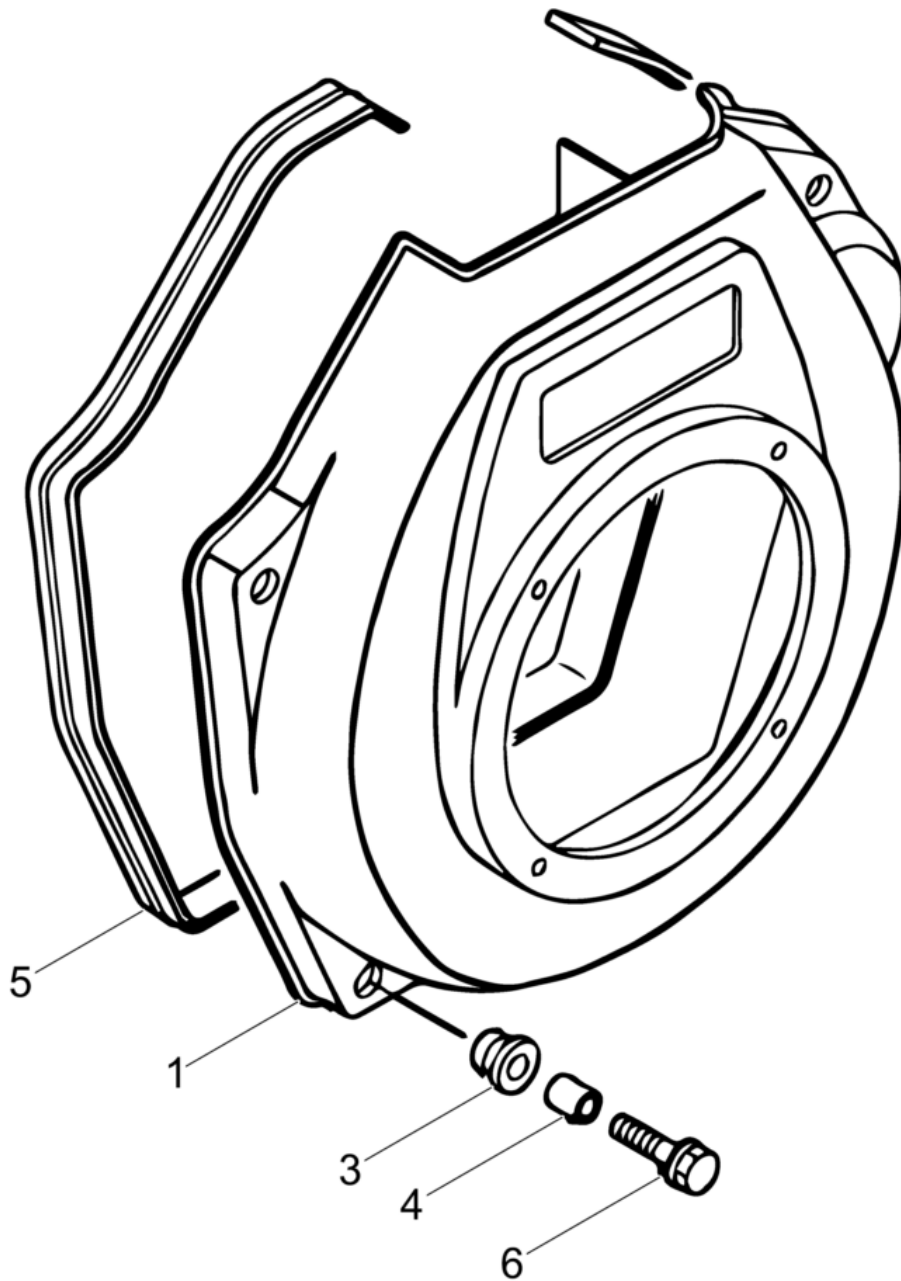

5100031934_01

Pos. Ref.	Artikel Nr. Part No.	Qty.	Unit	Beschreibung Descripcion	Description Description	Abm. Measur.	Norm Standard
						Drehm. Torque	Schmierstoff Sealant
1	5100030178	1	PC	Lüftergehäuse Caja del ventilador	Fan case Carter de ventilateur		
3	5000213238	4	PC	Tülle Ojal	Grommet Passe-fil		
4	5000210542	4	PC	Hülse Collar	Sleeve Douille		
5	5100030566	1	PC	Dichtung Empaque	Seal Joint		
6	5000213240	4	PC	Flanschschraube Tornillo de brida	Flange screw Vis de bride		

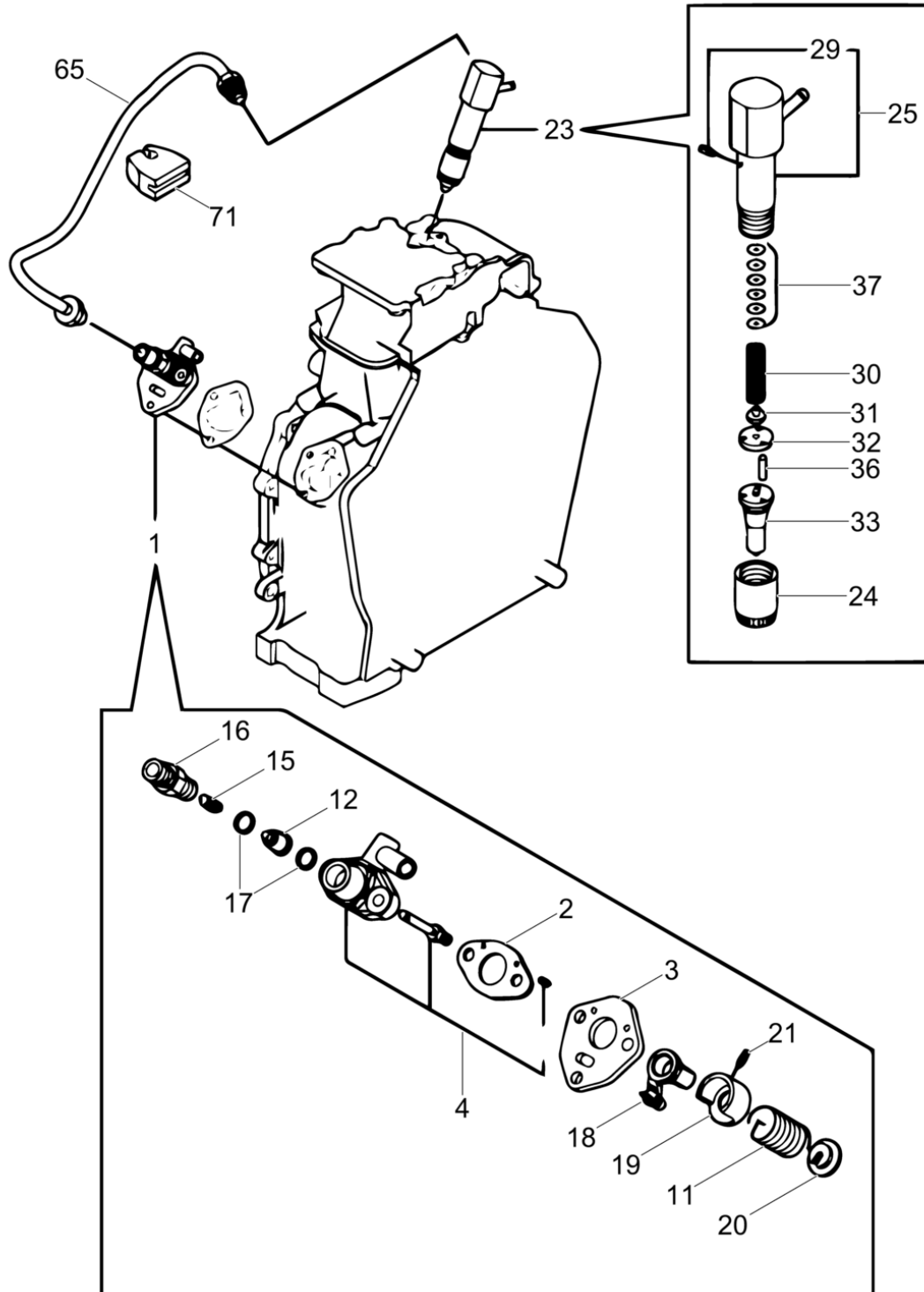

5100031935_01

Pos. Ref.	Artikel Nr. Part No.	Qty.	Unit	Beschreibung Descripcion	Description Description	Abm. Measur.	Norm Standard
						Drehm. Torque	Schmierstoff Sealant
1	5100031893	1	PC	Einspritzpumpe Kpl. Bomba de combustible compl.	Fuel pump cpl. Pompe à carburant compl.		
2	5000073705	1	PC	Dichtung Junta	Seal Joint		
3	5000119868	1	PC	Platte Placa	Plate Plaque		
4	5100030567	1	PC	Pumpengehäuse Caja de la bomba	Pump housing Carter de pompe		
10	5000119871	2	PC	Stift Espiga	Pin Goupille	2x6	
11	5000073708	1	PC	Feder Resorte	Spring Ressort		
12	5000150353	1	PC	Ventil Válvula	Valve Soupape		
15	5000073715	1	PC	Feder Resorte	Spring Ressort		
16	5000073716	1	PC	Halter Soporte	Bracket Support		
17	5000073717	2	PC	Dichtung Junta	Seal Joint		
18	5100031894	1	PC	Regulierhebel Palanca de mando	Control lever Lever de commande		
19	5000073724	1	PC	Sitz Asiento	Seat Siege		
20	5000119870	1	PC	Sitz Asiento	Seat Siege		
21	5000119872	1	PC	Stift Espiga	Pin Goupille	3x8	
23	5100031895	1	PC	Einspritzdüse Kpl. Bomba inyectora de combustible	Fuel injection pump Pompe d'injection à essence		
24	5000073728	1	PC	Mutter Tuerca	Nut Écrou		
25	5100000753	1	PC	Düsenhalter Kpl. Portainyector cpl.	Injector holder cpl. Porte-injecteur cpl.		
29	5100000763	1	PC	Spannstift Pasador de sujeción	Spring pin Goupille élastique	2,5Ax6	
30	5000073729	1	PC	Feder Resorte	Spring Ressort		
31	5000073730	1	PC	Federgehäuse Carcasa de resorte	Spring housing Logement du ressort		
32	5000073731	1	PC	Platte Placa	Plate Plaque		
33	5100031896	1	PC	Einspritzventil Kpl. Válvula inyectora compl.	Fuel injector valve cpl. Soupape d'injection compl.		
36	5000073732	2	PC	Stift Pasador	Pin Goupille		
37	5200020198	1	PC	Ausgleichscheiben Juego de laminillas	Shim set Jeu de cales		
65	5100031897	1	PC	Einspritzrohr Tubo inyector	Injection pipe Tube d'injection		
71	5100030192	1	PC	Konsole Soporte	Bracket Support		

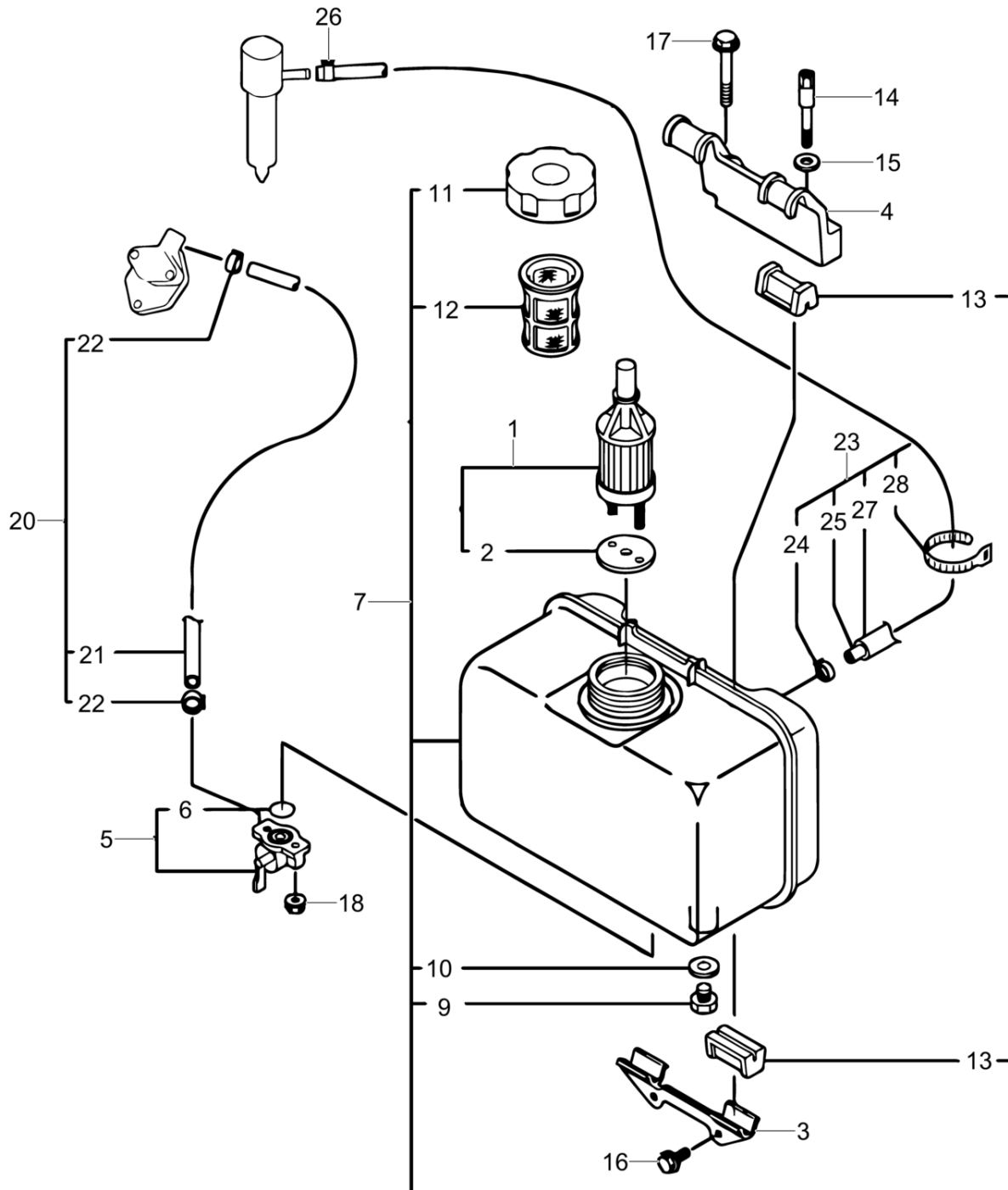

5100031936_01

Pos. Ref.	Artikel Nr. Part No.	Qty.	Unit	Beschreibung Descripción	Description Description	Abm. Measur.	Norm Standard
						Drehm. Torque	Schmierstoff Sealant
1	5000217895	1	PC	Kraftstofffilter Filtro de combustible	Fuel filter Filtre à carburant		
2	5000073746	1	PC	Dichtung Junta	Gasket Joint		
3	5000217876	1	PC	Konsole Consola	Console Console		
4	5100031898	1	PC	Konsole Soporte	Bracket Support		
5	5000153991	1	PC	Kraftstoffhahn Llave de combustible	Fuel cock Robinet d'essence		
6	5000073751	1	PC	O-Ring Anillo-o	O-ring Joint torique	15 x 1,3	
7	5100030568	1	PC	Kraftstofftank Kpl. Depósito de combustible compl.	Fuel tank cpl. Réservoir de carburant compl.		
9	5000213242	1	PC	Verschlusschraube Tapón roscado	Screw plug Vis de fermeture		
10	5000119882	1	PC	Dichtung Junta	Gasket Joint		
11	5000213241	1	PC	Kappe Tapa	Cap Chapeau		
12	5000213243	1	PC	Sieb Colador	Strainer Crépine		
13	5000073747	4	PC	Profilgummi Moldura	Molding Garniture		
14	5000217878	1	PC	Bolzen Perno	Bolt Boulon		
15	5000085567	1	PC	Scheibe Arandela	Washer Rondelle		
16	5000073659	2	PC	Schraube Tornillo	Screw Vis	M6 x 16 10Nm/7ft.lbs	
17	5000085536	1	PC	Schraube Tornillo	Screw Vis	M8 x 45 25Nm/18ft.lbs	
18	5000119722	2	PC	Mutter Tuerca	Nut Erou	M6	
20	5000210560	1	PC	Kraftstoffleitung Kpl. Tubo de combustible compl.	Fuel pipe cpl. Conduite de carburant compl.		
21	5000119891	1	PC	Rohr Tubo	Pipe Tube		
22	5000217931	2	PC	Schelle Abrazadera	Clamp Attache		
23	5100030189	1	PC	Rückleitungsrohr, Kpl. Acopl. del tubo de retorno	Return pipe cpl. Tuyau de retour compl.		
24	5000073714	1	PC	Schelle Abrazadera	Clamp Agrafe		
25	5100030190	1	PC	Rückleitungsrohr, Kpl. Acopl. del tubo de retorno	Return pipe cpl. Tuyau de retour compl.		
26	5100000762	1	PC	Schelle Abrazadera	Clamp Agrafe		
27	5100030191	1	PC	Schutzschlauch Manguera de protección	Protective hose Gaine de protection		
28	5200020222	1	PC	Kabelbinder Atadura de cable	Tie cable Serre-câble		

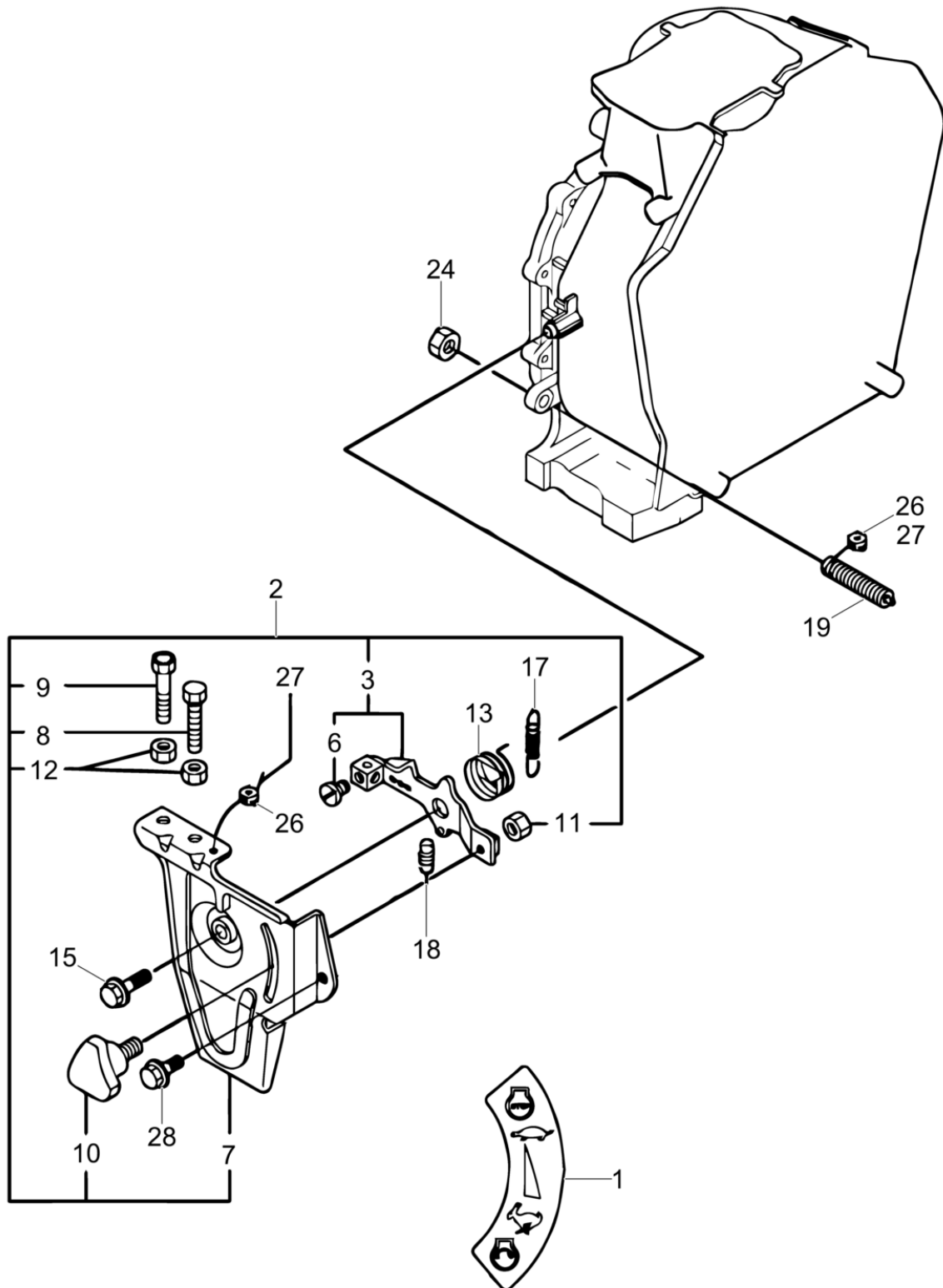

5100031937_01

Pos. Ref.	Artikel Nr. Part No.	Qty.	Unit	Beschreibung Descripción	Description Description	Abm. Measur.	Norm Standard
						Drehm. Torque	Schmierstoff Sealant
1	5100000745	1	PC	Aufkleber Calcomanía	Label Autocollant		
2	5100031899	1	PC	Gasreglerkonsole Ménsula-acelerador	Throttle control bracket Console-commande des gaz		
3	5100000727	1	PC	Hebel Palanca	Lever Levier		
6	5100000764	1	PC	Schraube Tornillo	Screw Vis	M5x8	
7	5100000728	1	PC	Halterung Soporte	Bracket Équerre		
8	5000210538	1	PC	Bolzen Perno	Bolt Boulon		
9	5000217829	1	PC	Einstellschraube Tornillo	Screw Vis		
10	5000073784	1	PC	Griff Empuñadura	Handle Poignée		
11	5100030160	1	PC	Mutter Tuerca	Nut Erou	M6	
12	5100031900	2	PC	Mutter Tuerca	Nut Erou	M6	
13	5000210536	1	PC	Rückholfeder Resorte	Spring Ressort		
14	5000210533	1	PC	Sechskantschraube Tornillo hexagonal	Hexagonal head cap screw Vis à tête hexagonale	M6 x 14	
15	5000150361	1	PC	Flanschschraube Tornillo de brida	Flange screw Vis de bride	M6 x 20	
17	5100031901	1	PC	Feder Resorte	Spring Ressort		
18	5100030564	1	PC	Rückholfeder Resorte	Spring Ressort		
19	5100031902	1	PC	Einstellschraube Kpl. Juego de limitador de combustible	Fuel limiter cpl. Jeu de limiteur d'essence	14	
24	5000210530	1	PC	Sechskantmutter Tuerca hexagonal	Hexagon nut Érou hexagonal	M10	
26	5000213254	2	PC	Plombe Soporte cable	Cable holder Attache		
27	5000119859	2	PC	Kabel Cable eléctrico	Electric wire Fil ressortant	0,6	

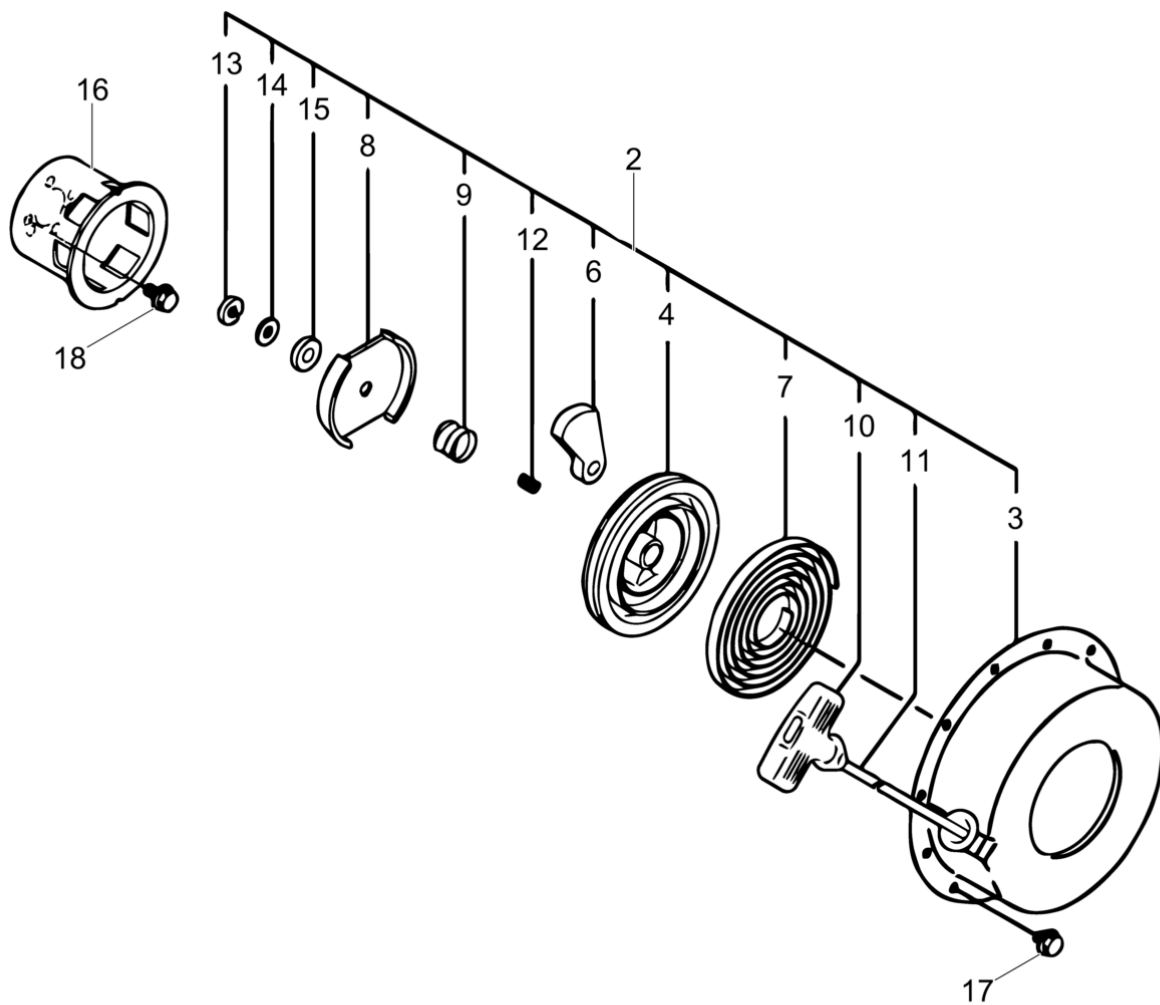

5100031938_01

Pos. Ref.	Artikel Nr. Part No.	Qty.	Unit	Beschreibung Descripción	Description Description	Abm. Measur.	Norm Standard
						Drehm. Torque	Schmierstoff Sealant
2	5100030206	1	PC	Reversierstarter Arrancador	Rewind starter Démarrreur		
3	5100030167	1	PC	Gehäuse Carcasa	Housing Carter		
4	5100030168	1	PC	Seilscheibe Polea	Pulley Poulie		
6	5100030169	2	PC	Ratsche Trinquete	Ratchet Cliquet		
7	5000210548	1	PC	Spiralfeder Resorte en espiral	Brush spring Ressort spirale		
8	5100030170	1	PC	Führung Guía	Ratchet guide Ancre		
9	5100030171	1	PC	Reibfeder Resorte de fricción	Friction spring Ressort de friction		
10	5000210553	1	PC	Startergriff Manija	Handle Poignée		
11	5100030172	1	PC	Starterseil Cuerda	Rope Corde		
12	5100030173	1	PC	Feder Resorte	Spring Ressort		
13	5100030174	1	PC	Sicherungsscheibe Disco	Washer Rondelle		
14	5100030175	1	PC	Scheibe Disco	Washer Rondelle		
15	5100030176	1	PC	Scheibe Disco	Washer Rondelle		
16	5100030177	1	PC	Starterscheibe Polea	Starter pulley Poulie de démarrage		
17	5000119905	4	PC	Schloßschraube Tornillo	Mushroom head bolt Vis	M 6x 8	
18	5000119897	3	PC	Schraube Tornillo	Screw Vis	M6x12	

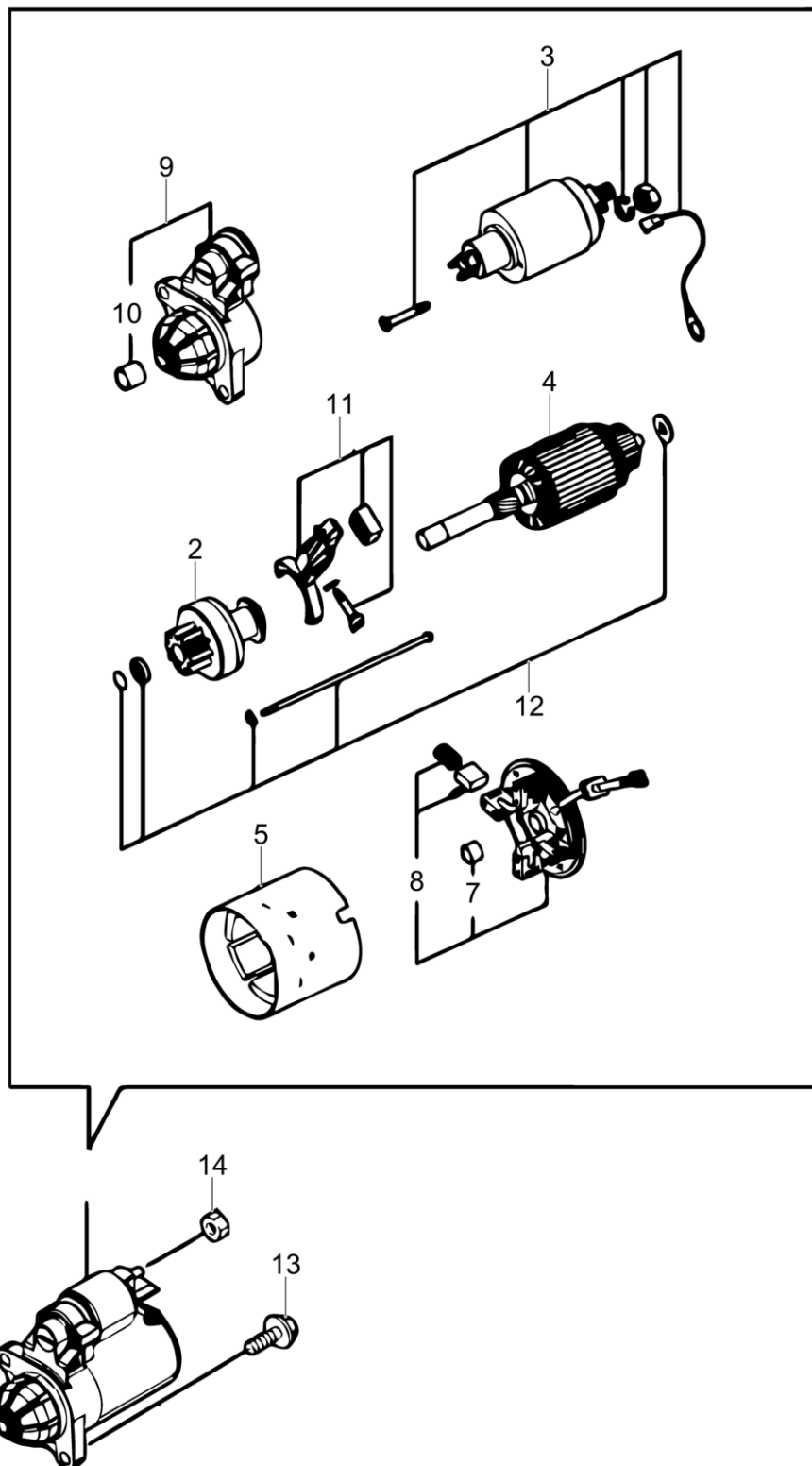

5100031939_01

Pos. Ref.	Artikel Nr. Part No.	Qty.	Unit	Beschreibung Descripcion	Description Description	Abm. Measuram.	Norm Standard
						Drehm. Torque	Schmierstoff Sealant
1	5100030208	1	PC	Starter Arrancador	Starter Démarrreur		
2	5000217543	1	PC	Ritzel Piñon diferencial	Pinion gear Pignon		
3	5000217540	1	PC	Magnetschalter Interruptor	Magnetic switch Commutateur		
4	5100030569	1	PC	Motorläufer Inducido del motor	Motor armature Rotor		
5	5100030570	1	PC	Erregerspule Bobina	Coil Bobine		
6	5000217546	1	PC	Deckel Kpl. Tapa	Cover Couvercle		
7	5000217548	1	PC	Buchse Buje	Bushing Douille		
8	5000217547	4	PC	Bürstenhalter Soporte de escobillas	Brush holder Porter balais		
9	5000217538	1	PC	Gehäuse Carcasa	Housing Enveloppe		
10	5000217539	1	PC	Buchse Buje	Bushing Douille		
11	5000217541	1	PC	Schalthebel Kpl. Palanca de cambios cpl.	Shift lever cpl. Levier de change cpl.		
12	5100030572	2	PC	Gewindebolzen Perno roscado	Threaded bolt Boulon fileté		
13	5000210585	2	PC	Schraube Tornillo	Screw Vis	M10 x 30	
14	5000119919	1	PC	Mutter Tuerca	Nut Ecrou	M8	

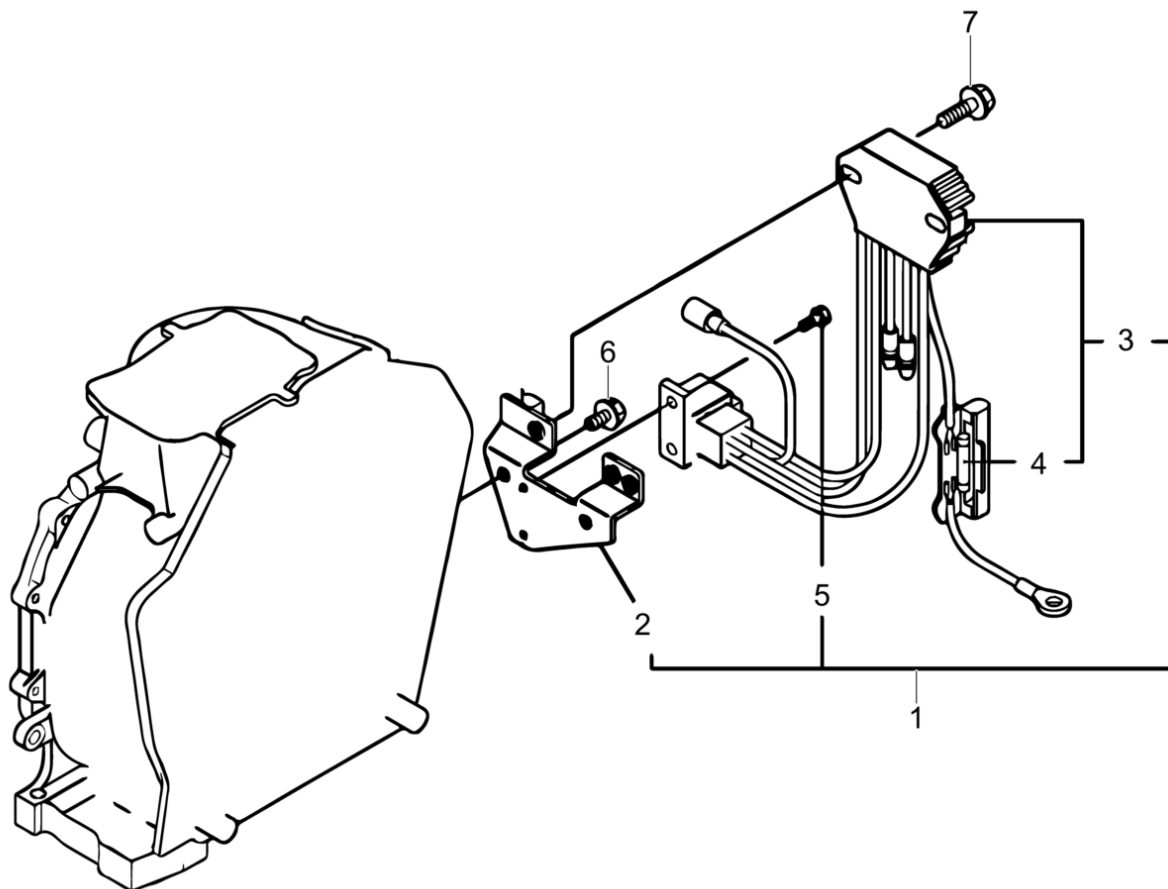

5100031940_01

Pos. Ref.	Artikel Nr. Part No.	Qty.	Unit	Beschreibung Descripción	Description Description	Abm. Measurement.	Norm Standard
						Drehm. Torque	Schmierstoff Sealant
1	5100030230	1	PC	Kabelbaum Conjunto de cables	Wiring harness Harnais de câbles électriques		
2	5100030573	1	PC	Halter Soporte	Bracket Équerre		
3	5100000757	1	PC	Kabelbaum Disp. del cable de elevación	Cable harness Faisceau de câbles		
4	5100000758	1	PC	Sicherung Fusible	Fuse Fusible		
5	5000210593	2	PC	Schraube Tornillo	Screw Vis	M4 x 10	
6	5000119897	2	PC	Schraube Tornillo	Screw Vis	M6x12	
7	5000150361	2	PC	Flanschschraube Tornillo de brida	Flange screw Vis de bride	M6 x 20	

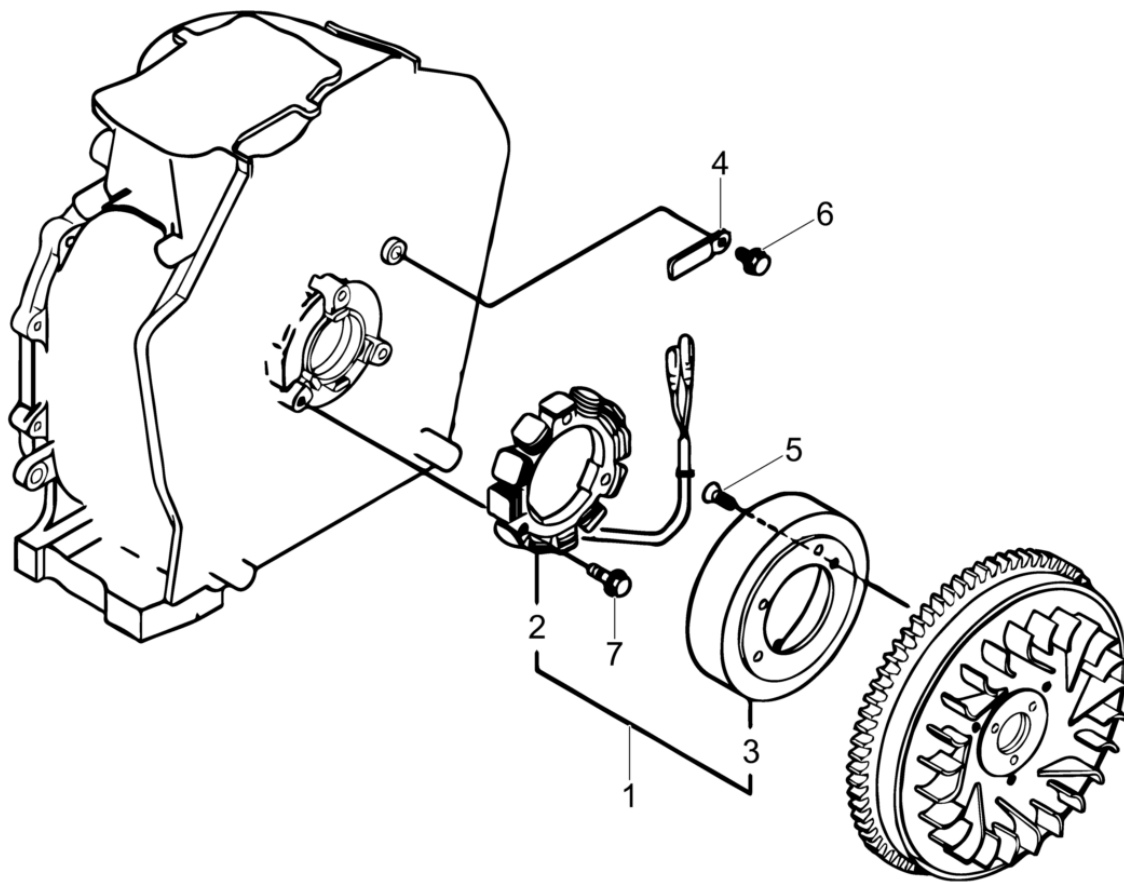

5100031941_01

Pos. Ref.	Artikel Nr. Part No.	Qty.	Unit	Beschreibung Descripcion	Description Description	Abm. Measuram.	Norm Standard
						Drehm. Torque	Schmierstoff Sealant
1	5100000759	1	PC	Lichtmaschine Dinamo	Dynamo Dynamo		
2	5100000760	1	PC	Stator Estator	Stator Stator		
3	5100000761	1	PC	Rad Rueda	Wheel Roue		
4	5000210589	1	PC	Klammer Grampa	Clamp Pince		
5	5100030574	3	PC	Schraube Tornillo	Screw Vis	M6	
6	5000119897	1	PC	Schraube Tornillo	Screw Vis	M6x12	
7	5000150361	3	PC	Flanschschraube Tornillo de brida	Flange screw Vis de bride	M6 x 20	

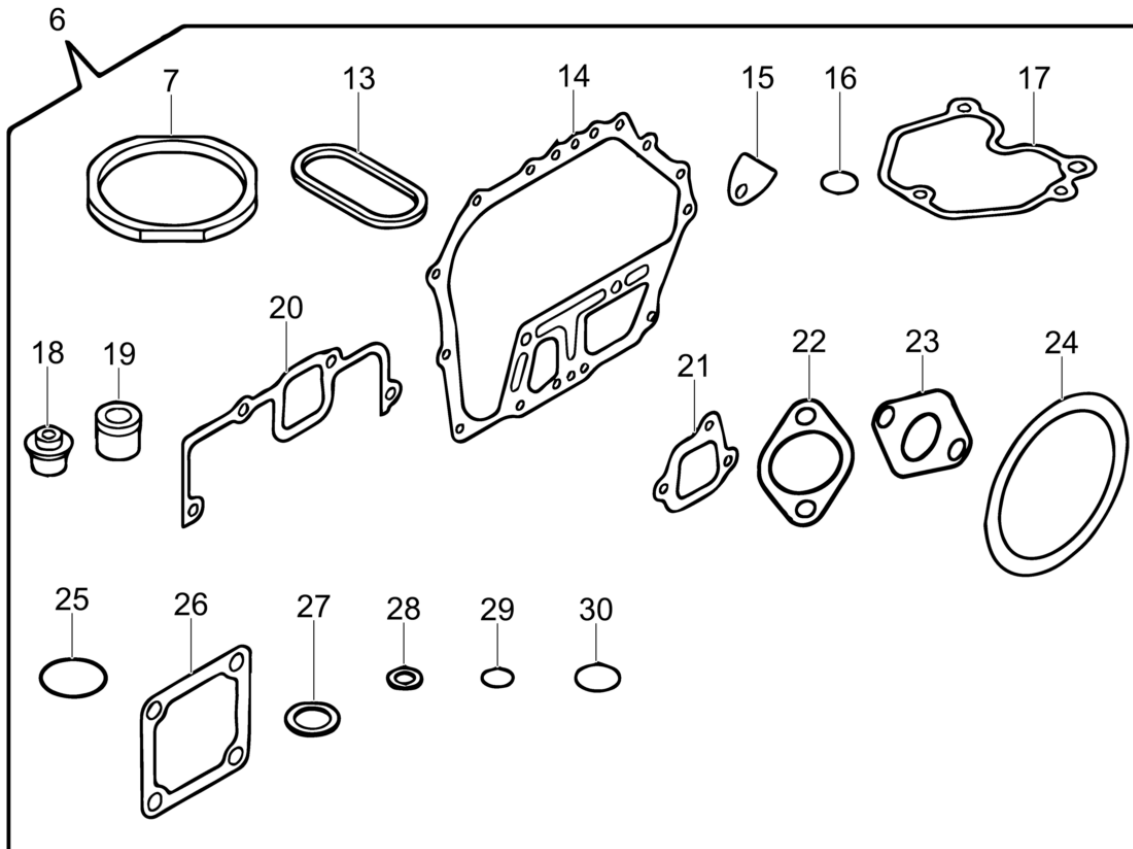
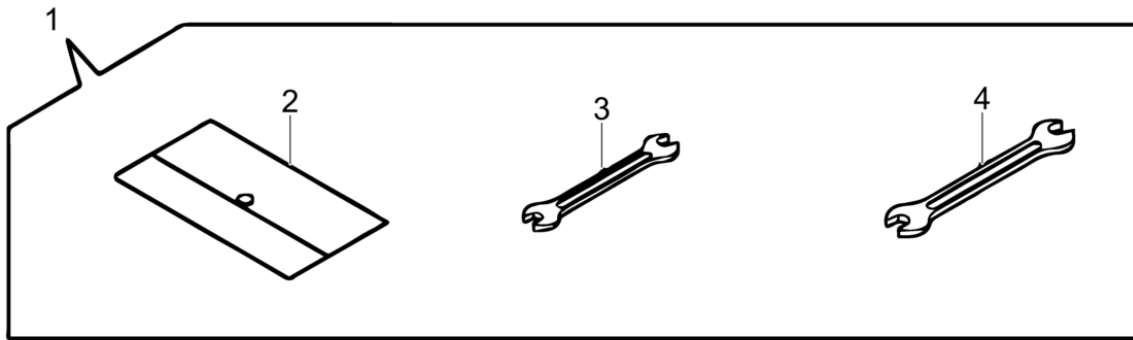

5100031942_01

Pos. Ref.	Artikel Nr. Part No.	Qty.	Unit	Beschreibung Descripcion	Description Description	Abm. Measur.	Norm Standard
						Drehm. Torque	Schmierstoff Sealant
1	5000210604	1	PC	Werkzeuge Juego de herramientas	Tool set Trousse à réparation		
2	5000210604	1	PC	Werkzeuge Juego de herramientas	Tool set Trousse à réparation		
3	5000210606	1	PC	Dichtung Junta	Gasket Joint		
4	5000210607	1	PC	Dichtung Junta	Gasket Joint		
6	5100031929	1	PC	Dichtungssatz Juego de juntas	Gasket set Jeu de joints		
7	5100031962	1	PC	Kopfdichtung Junta de culata	Head gasket Joint de culasse		
13	5100031772	1	PC	O-Ring Anillo-o	O-ring Joint torique		
14	5100031773	1	PC	Kurbelgehäusedichtung Junta del cárter	Crankcase gasket Joint de carter		
15	5000073612	1	PC	Dichtung Junta	Gasket Joint		
16	5000073609	2	PC	O-Ring Anillo-o	O-ring Joint torique	18 x 2,2	
17	5100031848	1	PC	Zylinderkopfdichtung Junta de culata del cilindro	Cylinder head gasket Joint de culasse de cylindre		
18	5100031963	2	PC	Dichtung Empaque	Seal Joint		
19	5000119738	1	PC	Dichtung Junta de estanqueidad	Gasket Garniture		
20	5100031811	1	PC	Luftfilterdichtung Junta filtro de aire	Air filter seal Joint filtre à air		
21	5100031964	2	PC	Luftfilterdichtung Junta filtro de aire	Air cleaner gasket Joint filtre à air		
22	5100031965	1	PC	Luftfilterdichtung Junta filtro de aire	Air cleaner gasket Joint filtre à air		
23	5100031815	1	PC	Dichtung Junta	Gasket Joint		
24	5100031966	1	PC	Dichtung Junta	Gasket Joint		
25	5000210618	1	PC	O-Ring Anillo-o	O-ring Joint torique		
26	5100031967	3	PC	Dichtung Junta	Gasket Joint		
27	5000073608	2	PC	Scheibe Arandela	Washer Rondelle		
28	5000119882	1	PC	Dichtung Junta	Gasket Joint		
29	5000073751	1	PC	O-Ring Anillo-o	O-ring Joint torique	15 x 1,3	
30	5000073693	1	PC	O-Ring Anillo-o	O-ring Joint torique	22,4 x 1,8	

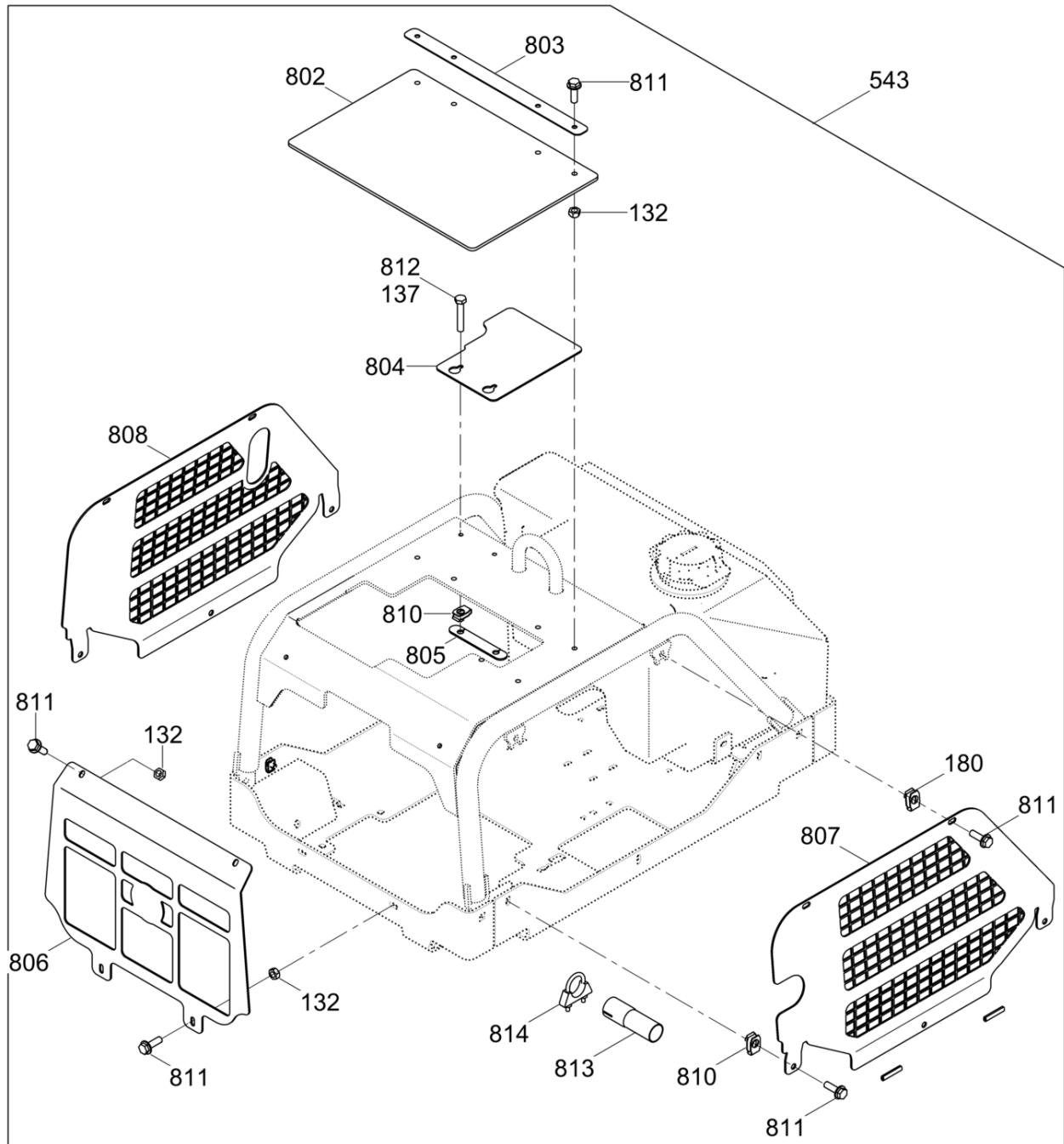

5100032149_01

Pos. Ref.	Artikel Nr. Part No.	Qty.	Unit	Beschreibung Descripción	Description Description	Abm. Measur.	Norm Standard
						Drehm. Torque	Schmierstoff Sealant
132	5000010367	8	PC	Sechskantmutter Tuerca hexagonal	Hexagon nut Écrou hexagonal	M8	DIN985
180	5200002421	4	PC	Klemmutter Sujetador	Clip nut Agrafe	M8 X 1/4	
802	5100030210	1	PC	Deckplatte Placa de cubierta	Cover plate Couvercle de protection		
803	5200025027	1	PC	Deckplatte Placa de cubierta	Cover plate Couvercle de protection		
804	5200025026	1	PC	Schutzblech Placa de protección	Guard plate Plaque de protection		
805	5200025032	1	PC	Anbauplatte Placa-montaje	Mounting plate Plaque-montage		
806	5200025029	1	PC	Motorschutz Protector del motor	Engine guard Protecteur du moteur		
807	5100030079	1	PC	Schutzrahmen Chasis protector	Protective frame Cadre de protection		
808	5200025031	1	PC	Motorschutz Protector del motor	Engine guard Protecteur du moteur		
809	5000222086	1	PC	Aufkleber Symbol Calcomania símbolo	Label symbol Autocollant symbole		
810	5000110969	8	PC	Klemmutter Sujetador	Clip nut Agrafe	M8	
811	5000155213	18	PC	Schraube Tornillo	Screw Vis	M8 x 25 25Nm/18ft.lbs	
812	5000011453	2	PC	Sechskantschraube Tornillo hexagonal	Hexagonal head cap screw Vis à tête hexagonale	M8 x 45 25Nm/18ft.lbs	DIN933
813	5100030211	1	PC	Auspuffrohr Tubo de escape	Exhaust tube Tube d'échappement		
814	5000111081	1	PC	Auspuffschele Abrazadera de escape	Exhaust clamp Agrafe d'échappement		



**WACKER
NEUSON**

