



**WACKER
NEUSON**

**Ersatzteilkatalog
Spare parts list
Catalogo de piezas de repuesto
Catalogue des pièces détachées**

**Vibrationsplatte
Vibratory plate
Plancha vibratoria
Plaque vibrante**

VP1550Aw



Type	VP1550Aw
Material Number	5100029056
Version	101
Language	de en es fr



www.wackerneuson.com

Copyright © 08.2019
Wacker Neuson Produktion GmbH & Co. KG
Printed in Germany.
All rights reserved.

Ein Typenschild mit Typ, Artikelnummer, Version und Maschinen-Nummer ist an jedem Gerät angebracht. Die Daten von diesem Schild bitte notieren, damit sie auch bei Verlust oder Beschädigung des Schildes noch vorhanden sind. Der Typ, die Artikelnummer, die Versions-Nummer und die Maschinen-Nummer sind bei der Ersatzteilbestellung oder Nachfragen bezüglich Service-Informationen stets erforderlich.

Bei den in den Ersatzteillisten fettgedruckten Nummern handelt es sich um empfohlene Ersatzteile. Dies bedeutet, daß diese Teile bei normalen Anwendungsbedingungen natürlicher Abnutzung ausgesetzt sind und gelegentlich ersetzt oder überarbeitet werden müssen. Es wird geraten, diese Teile auf Lager bereit zu haben, um für Service-Arbeiten an diesem Gerät vorbereitet zu sein. Lagerbestände für diese und andere Teile, welche für ausgiebigere Reparaturarbeiten benötigt werden, können je nach Service-Gewohnheiten der einzelnen Kunden variieren.

Die Nummern meines Gerätes sind:

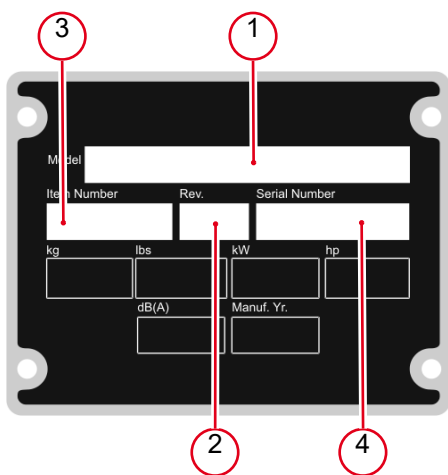

1. Typ
2. Version
3. Artikel-Nr.
4. Maschinen-Nr.

Umrechnungstabelle

Volumeneinheit	
1 ml	0.034 US fl.oz.
1 l	0.260 gal
Längeneinheit	
1 mm	0.039 in
1 m	3.280 ft
Gewicht	
1 kg	2.200 lbs
1 g	0.035 oz
Geschwindigkeit	
1 km/h	0.620 mph
Drehmoment	
1 Nm	0.740 ft.lbs

A nameplate listing the Model Number, Item Number, Revision, and Serial Number is attached to each unit. Please record the information found on this plate so it will be available should the nameplate become lost or damaged. When ordering parts or requesting service information, you will always be asked to specify the model, item number, revision number, and serial number of the unit.

Part Numbers appearing in boldface type are recommended spare parts. This means that these parts are subject to wear under normal operating conditions and may require periodic service or replacement. It is recommended that these items be stocked to meet the expected service requirements of this model. Actual stocking quantities of these and other parts used in more extensive repairs will depend on the service practices of each customer.

My machine's numbers are:

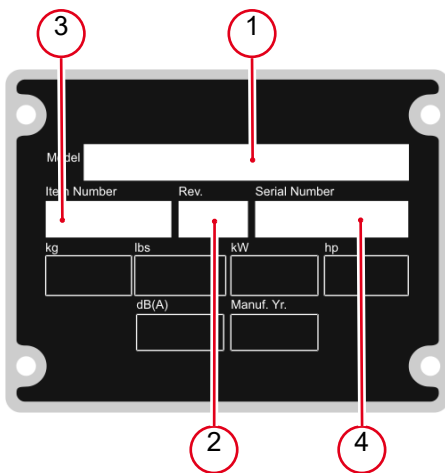

- 1. Model
- 2. Revision
- 3. Item No.
- 4. Serial No.

Conversion table

Volume unit	
1 ml	0.034 US fl.oz.
1 l	0.260 gal
Unit of length	
1 mm	0.039 in
1 m	3.280 ft
Weight	
1 kg	2.200 lbs
1 g	0.035 oz
Speed	
1 km/h	0.620 mph
Torque	
1 Nm	0.740 ft.lbs

Una placa de identificación con el modelo, número de referencia, nivel de revisión y número de serie ha sido añadida en cada máquina. Favor de anotar los datos en la placa en caso de que la placa de identificación sea destruida o perdida. En todos los pedidos para repuestos necesita siempre el modelo, el número de referencia, el nivel de revisión y el número de serie de la máquina en cuestión.

Los números de partes en negritas en las Listas Ilustradas de Partes son los repuestos recomendados, esto quiere decir que estas partes se desgastarán bajo circunstancias de funcionamiento normales y pueden requerir servicio periódico o su reemplazo. Se recomienda que el cliente mantenga un abastecimiento adecuado de estas partes para poder satisfacer la demanda requerida por el servicio a la máquina. La cantidad de repuestos que el cliente necesitará para reparaciones dependerá de la póliza de servicio de cada cliente.

Los números de mi máquina son:

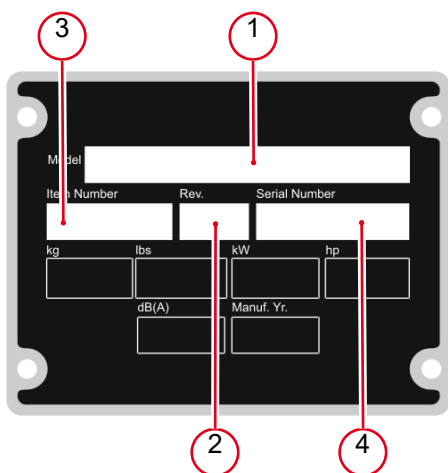

- 1. Modelo
- 2. Nivel de revisión
- 3. Número de referencia
- 4. Número de Serie

Tabla de conversión

Unidad de volumen	
1 ml	0.034 US fl.oz.
1 l	0.260 gal
Unidad de longitud	
1 mm	0.039 in
1 m	3.280 ft
Peso	
1 kg	2.200 lbs
1 g	0.035 oz
Velocidad	
1 km/h	0.620 mph
Par de apriete	
1 Nm	0.740 ft.lbs



Une plaque signalétique mentionnant le modèle, le numéro de référence, le niveau de revision et le numéro de série est fixée sur chaque machine. Veuillez noter les informations relevées sur cette plaque de façon à ce qu'elles soient toujours disponibles si la plaque signalétique venait à être perdue ou endommagée. Lorsque vous commandez des pièces détachées ou vous sollicitez des informations après-vente, on vous demandera toujours de préciser le modèle, le numéro de référence, le niveau de revision et le numéro de série de la machine.

Les numéros de pièces imprimés en caractères gras dans les Listes des Pièces Détachées de ce manuel sont les pièces détachées recommandées par la Wacker. Cela veut dire que ces pièces sont sujettes à usure dans des conditions de travail normales et peuvent nécessiter de l'entretien ou leur remplacement. Nous recommandons que vous disposez d'un stock de ces pièces pour pouvoir satisfaire la demande d'entretien de cette machine. Le client doit décider lui-même de la quantité exacte de pièces de rechange qu'il disposera dans ses stocks.

Les numéros de ma machine sont :

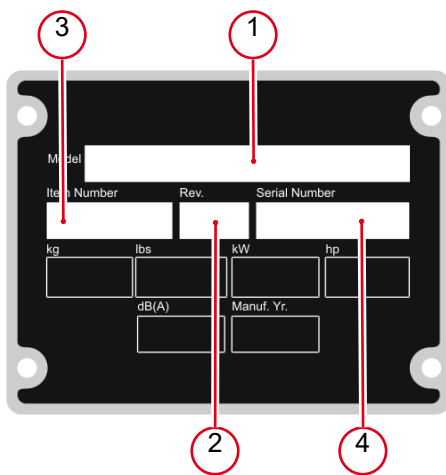

1. Typ
2. Version
3. Artikel-Nr.
4. Maschinen-Nr.

Table de conversion

Unité de volume	
1 ml	0.034 US fl.oz.
1 l	0.260 gal
Unité de longueur	
1 mm	0.039 in
1 m	3.280 ft
Poids	
1 kg	2.200 lbs
1 g	0.035 oz
Vitesse	
1 km/h	0.620 mph
Couple de serrage	
1 Nm	0.740 ft.lbs

Vibrationsplatte
Vibration plate
Plancha vibradora
Plaque vibrante 10

Vibrationsplatte
Vibration plate
Plancha vibradora
Plaque vibrante 12

Untermasse Kpl.
Baseplate cpl.
Masa inferior cpl.
Masse inferieure cpl. 14

Berieselungsanlage Kpl.
Water system cpl.
Sistema de rociado cpl.
Système diffuseur cpl. 16

Aufkleber
Labels
Calcomanías
Autocollants 18

Motor
Engine
Motor
Moteur

Seilzugstarter
Starter
Arrancador
Démarreur 20

Gebläseabdeckung
Fan hood
Tapa de ventilador
Couvercle du sys. de vent. 22

Vergaser
Carburetor
Carburador
Carburateur 24

Luftfilter
Air cleaner
Filtro del aire
Filtre à air 28

Schalldämpfer
Muffler
Silenciador
Silencieux 30

Kraftstofftank
Fuel tank
Depósito de combustible
Réservoir à essence 32



Schwungrad Fly wheel Volante Volant	34
--	----

Zylinderkopf Cylinder head Culata Culasse	36
--	----

Zündspule Ignition coil Bobina de encendido Bobine d'allumage	38
--	----

Regler Governor Regulador Régulateur	40
---	----

Zylindergehäuse Cylinder housing Carcasa de cilindro Carter cylindre	42
---	----

Kurbelgehäuseabdeckung Crankcase cover Cubierta da la caja de manivel Couvercle carter de manivelle	44
--	----

Kurbelwelle Crankshaft Cigueñal Vilebrequin	46
--	----

Kolben Piston Pistón Piston	48
--	----

Nockenwelle Camshaft Arbol de levas Arbre à cames	50
--	----

Aufkleber Labels Calcomanias Autocollants	52
--	----

Zubehör Accessoires Accesorios Accessories	
---	--

Radsatz Kpl. Alt Wheel kit cpl. old Juego de rueda cpl. vieja Jeu de roue cpl. vieux	54
---	----

Fahrgestell Kpl.
Trolley cpl.
Dispositivo de transporte cpl.
Chassis cpl. 58

Gleitvorrichtung
Urethane pad kit
Placa de deslizamiento
Jeu de tapis en polyuréthane 60

Berieselungsanlage Kpl.
Water system cpl.
Sistema de rociado cpl.
Système diffuseur cpl. 62

Arretierung Bügel
Lock shackle
Dispositivo de retenciónestribo
Dispositif d'arrêt étrier 64

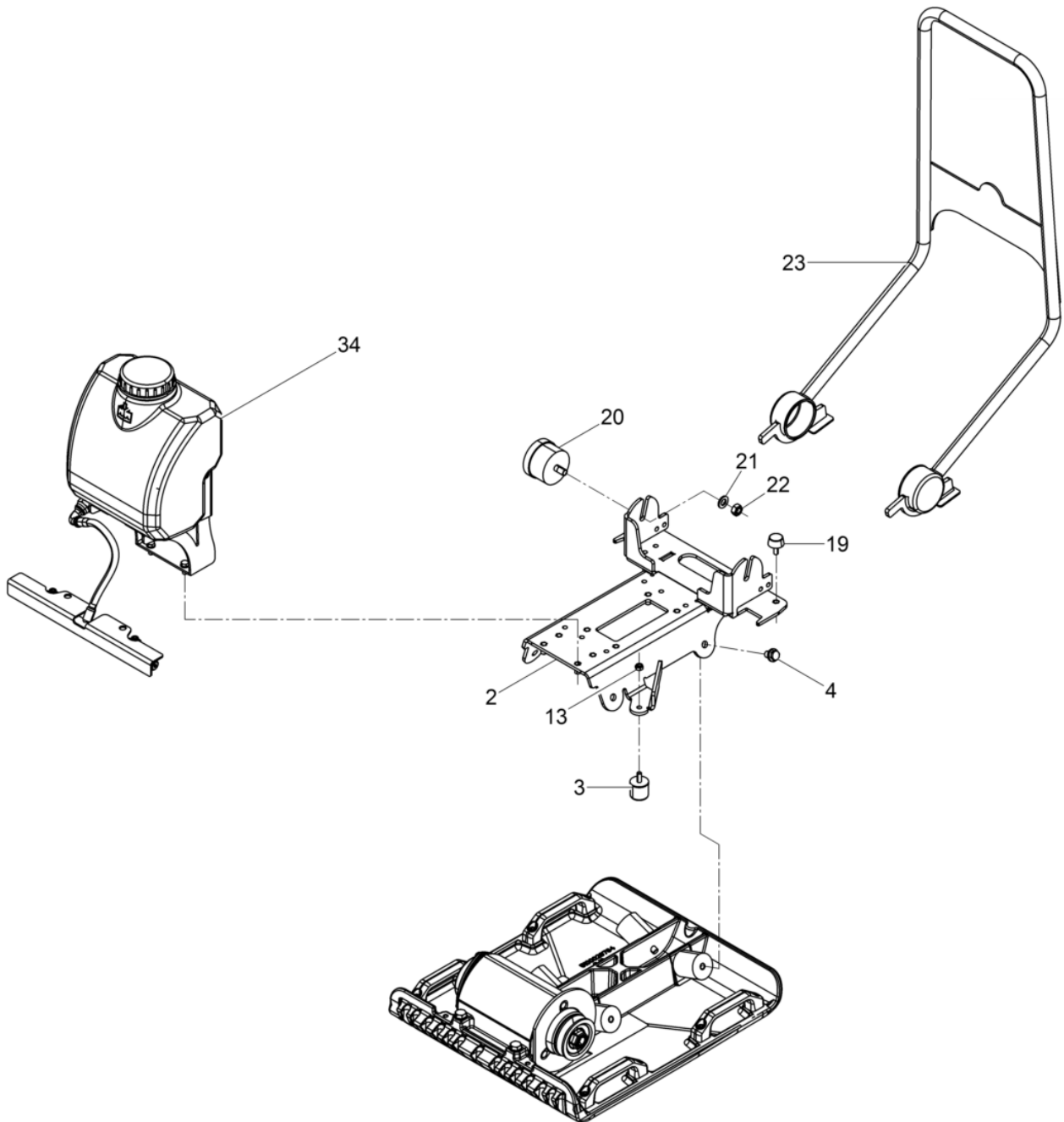

Pos. Ref.	Artikel Nr. Part No.	Qty.	Unit	Beschreibung Description	Description Description	Abm. Measur.	Norm Standard
						Drehm. Torque	Schmierstoff Sealant
2	5100028852	1	PC	Obermasse Masa superior	Upper mass Massa superieure		
3	5100016327	1	PC	Anschlagpuffer Amortiguador	Shockmount Silentbloc	35 x 40	
4	5100024478	4	PC	Sicherungsschraube Tornillo	Corrugated-head screw Vis	M12x 16	
13	5000033356	1	PC	Sechskantmutter Tuerca hexagonal	Hexagon nut Écrou hexagonal		
19	5100016317	2	PC	Anschlagpuffer Amortiguador	Shockmount Silentbloc	30 x 15	
20	5000106557	2	PC	Gummi-Metall-Puffer Tope caucho-metal	Shockmount Tampon métallique oscillant		
21	5000010620	2	PC	Scheibe Arandela	Flat washer Rondelle	12	ISO7090
22	5000010884	2	PC	Sechskantmutter Tuerca hexagonal	Hexagon nut Écrou hexagonal	M12	DIN934
23	5100028666	1	PC	Bügel Manija	Handle Poignée		
34	5100029067	1	PC	Berieselung Sistema de rociado	Water system Système diffuseur		

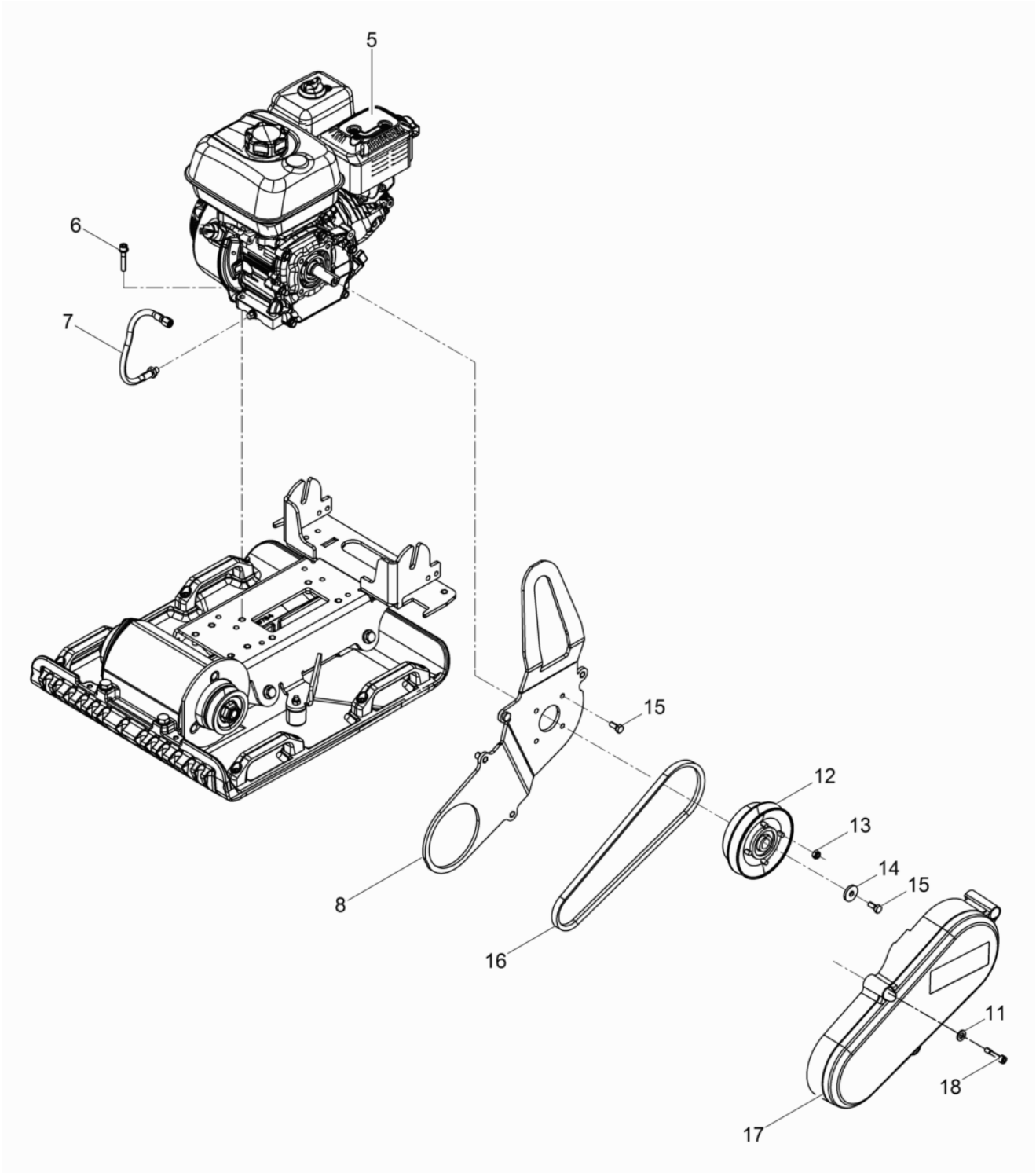

Pos. Ref.	Artikel Nr. Part No.	Qty.	Unit	Beschreibung Description	Description Description	Abm. Measur.	Norm Standard
						Drehm. Torque	Schmierstoff Sealant
5	5100018834	1	PC	Benzinmotor Motor a gasolina	Gas engine Moteur à essence		
6	5100029786	4	PC	Zylinderschraube Tornillo cilíndrico	Cheese head screw Vis à tête cylindrique		
7	5000129265	1	PC	Schlauchleitung Conducto flexible	Hose pipe Conduite flexible		
8	5100029000	1	PC	Kranblech Kpl. Chapa cpl.	Plate cpl. Tôle cpl.		
11	5100044732	3	PC	Scheibe Disco	Disc Disque		
12	5100016313	1	PC	Fliehkraftkupplung Embrague centrifugo	Centrifugal clutch Embrayage centrifuge		
13	5000033356	4	PC	Sechskantmutter Tuerca hexagonal	Hexagon nut Écrou hexagonal		
14	5100016321	1	PC	Scheibe Arandela	Washer Rondelle		
15	5000026169	5	PC	Sechskantschraube Tornillo hexagonal	Hexagonal head cap screw Vis à tête hexagonale	5/16in-24UNF-2Ax 3/4in 18Nm/13ft.lbs	
16	5100031195	1	PC	Keilriemen Correa en v	V-belt Courroie		
17	5100028911	1	PC	Riemenschutz Protección de la polea	Belt guard Protection de courroie		
18	5000216658	3	PC	Dünnschaftschraube Tornillo	Screw Vis	M 8x 38	

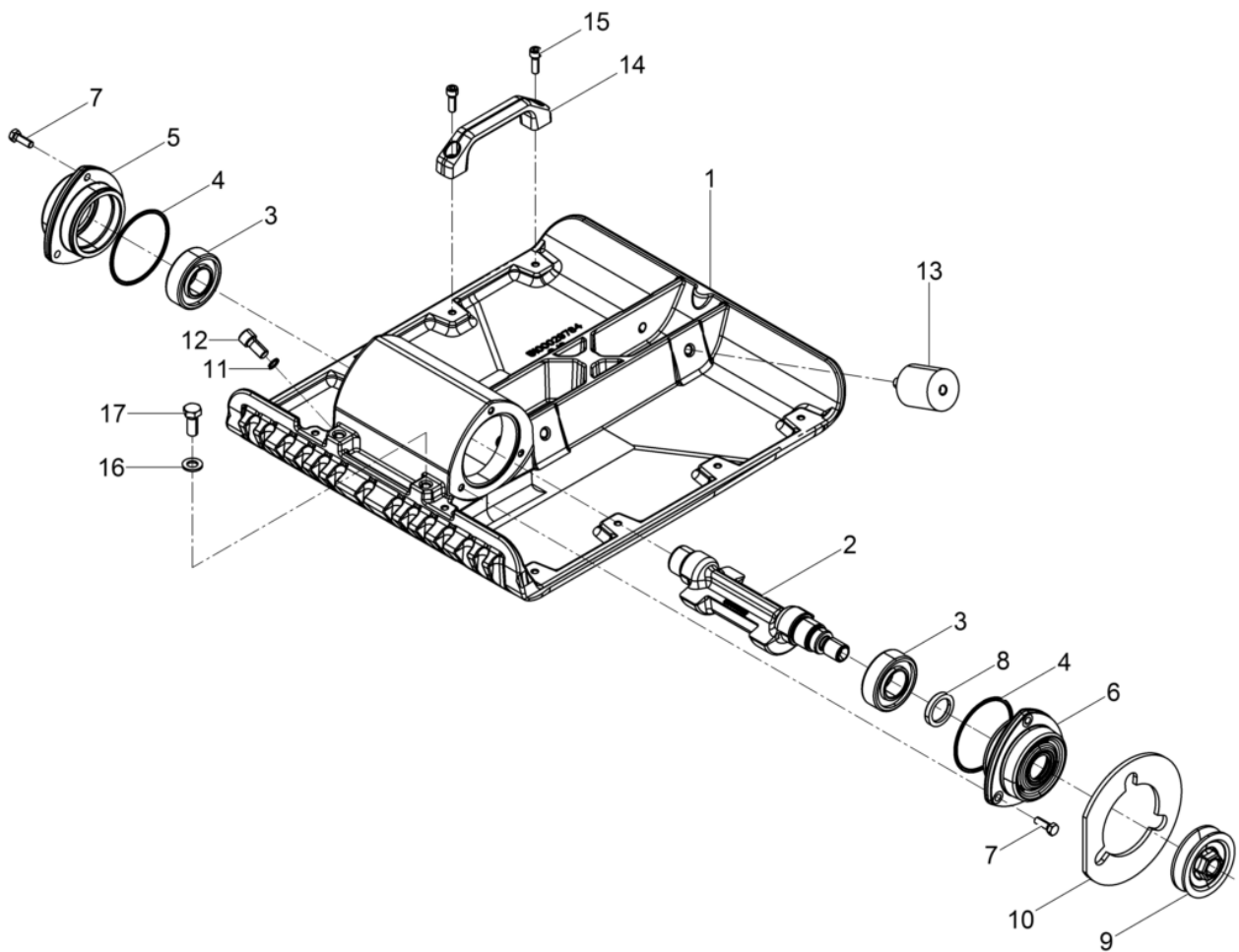

Pos. Ref.	Artikel Nr. Part No.	Qty.	Unit	Beschreibung Description	Description Description	Abm. Measur.	Norm Standard
						Drehm. Torque	Schmierstoff Sealant
1	5100029785	1	PC	Untermasse Masa inferior	Baseplate Masse inferieure		
2	5100018133	1	PC	Unwuchtwelle Eje de la masa excéntrica	Eccentric shaft Arbre portant l'excentrique		
3	5100018326	2	PC	Zylinderrollenlager Rodamiento cilíndricos	Cylindrical roller bearing Roulement à rouleaux		
4	5100016445	2	PC	O-Ring Anillo-o	O-ring Bague-o	88,49 x 3,53	
5	5100022486	1	PC	Lagerschild Placa de cojinete	Bearing bracket Bride palier		
6	5100022485	1	PC	Lagerschild Placa de cojinete	Bearing bracket Bride palier		
7	5000011457	6	PC	Sechskantschraube Tornillo hexagonal	Hexagonal head cap screw Vis à tête hexagonale	M8 x 25 31Nm/23ft.lbs	
8	5100016446	1	PC	Wellendichtring Anillo de retén radial	Rotary shaft seal Bague d'étanchéité	B 30 x 42 x 7	
9	5100022460	1	PC	Keilriemenscheibe Polea en v	V-belt pulley Poulie à courroie		
10	5100028857	1	PC	Dichtung Junta	Gasket Joint		
11	5000124908	1	PC	Dichtring Anillo de junta	Gasket Bague d'étanchéité	A12 x 15,5	DIN7603
12	5000011530	1	PC	Zylinderschraube Tornillo cilíndrico	Cheese head screw Vis à tête cylindrique	M12 x 25	ISO4762
13	5100016316	4	PC	Gummi-Metall-Puffer Tope caucho-metal	Shockmount Tampon métallique oscillant	50x55	
14	5100024557	4	PC	Bügelgriff Empuñadura de estribo	Bow handle Poignée detrier		
15	5100029787	8	PC	Zylinderschraube Tornillo cilíndrico	Cheese head screw Vis à tête cylindrique		
16	5000010620	2	PC	Scheibe Arandela	Flat washer Rondelle	12	ISO7090
17	5000011423	2	PC	Sechskantschraube Tornillo hexagonal	Hexagonal head cap screw Vis à tête hexagonale	M12 x 30 86Nm/63ft.lbs	DIN933

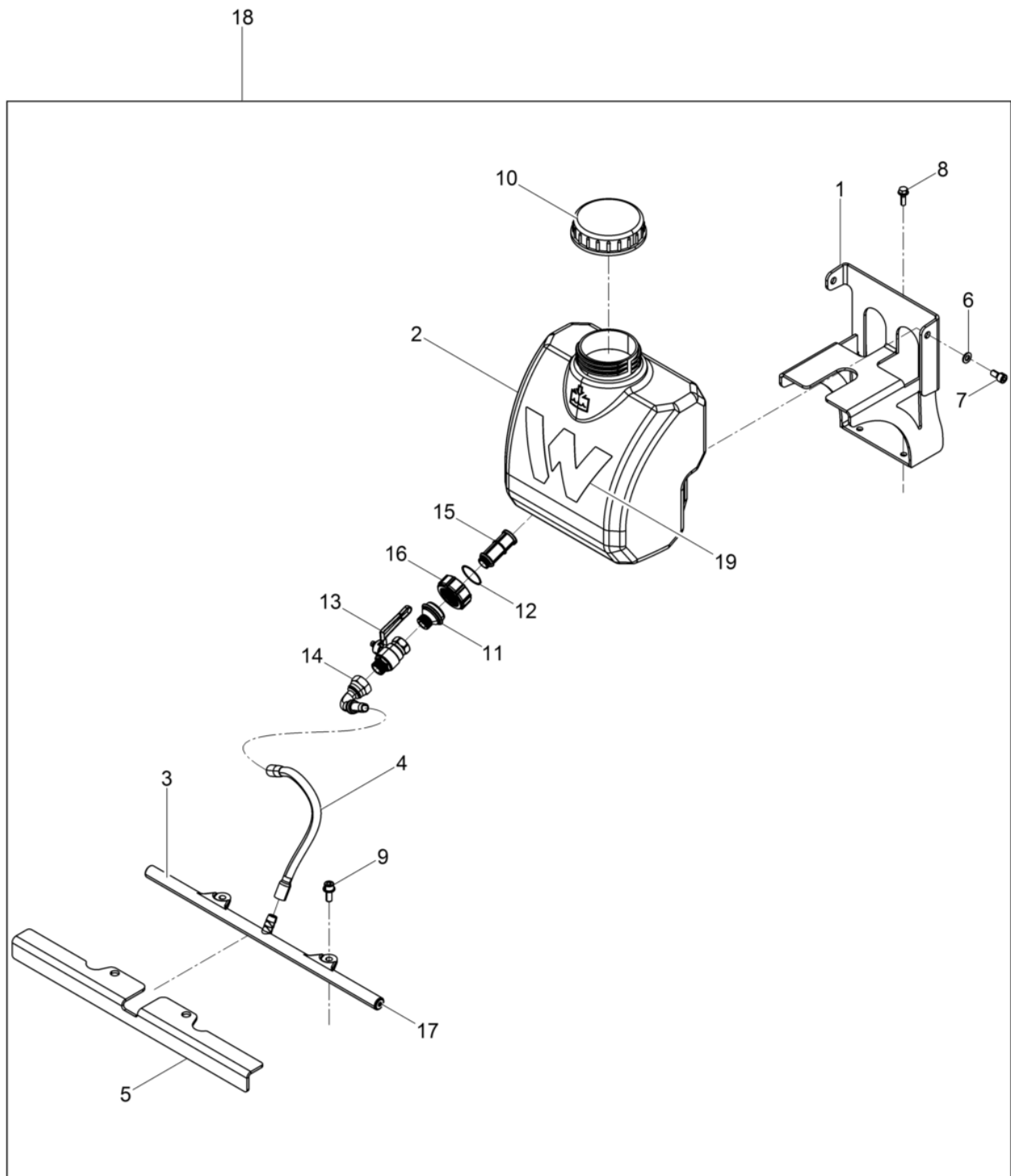

Pos. Ref.	Artikel Nr. Part No.	Qty.	Unit	Beschreibung Descripcion	Description Description	Abm. Measur.	Norm Standard
						Drehm. Torque	Schmierstoff Sealant
1	5100028912	1	PC	Wassertankhalterung Soporte	Fixing device Bague de retenue		
2	5100028898	1	PC	Wassertank Tanque de agua	Watertank Reservoir à eau		
3	5100029616	1	PC	Berieselung Kpl. Systema de riego cpl.	Spinkler system cpl. Installation d'arrosage cpl.		
4	5100028892	1	PC	Wasserschlauch Manguera de agua	Water hose Tuyau d'eau		
5	5100030990	1	PC	Schutzblech Chapa protectora	Guard plate Tôle de protection		
6	5000010622	2	PC	Scheibe Arandela	Flat washer Rondelle		
7	5000011544	2	PC	Zylinderschraube Tornillo cilíndrico	Cheese head screw Vis à tête cylindrique	M8 x 16 25Nm/18ft.lbs	ISO4762
8	5100035900	4	PC	Sechskantschraube Tornillo hexagonal	Hexagonal head cap screw Vis à tête hexagonale		
9	5100042618	2	PC	Zylinderschraube Tornillo cilíndrico	Cheese head screw Vis à tête cylindrique		
10	5000068351	1	PC	Schraubdeckel Tapa roscable	Screwed cover Couvercle fileté		
11	5100028921	1	PC	Flansch Brida	Flange Bride		
12	5100028922	1	PC	O-Ring Anillo-o	O-ring Bague-o		
13	5100028889	1	PC	Kugelhahn Llave esférica	Ball valve Robinet à boisseau sqherique		
14	5100028897	1	PC	Pressnippel Conector	Connector Connexion		
15	5100028890	1	PC	Wasserfilter Filtro de agua	Water filter Filtre		
16	5100028920	1	PC	Überwurfmutter Tuerca de racor	Cap screw Écrou d'accouplement		
17	5100029615	2	PC	Einschraubstopfen Tapón	Plug Bouchon		
18	5100029067	1	PC	Berieselung Sistema de rociado	Water system Système diffuseur		
19	1000360098	1	PC	Aufkleber Calcomania	Label Autocollant		

Pos. Ref.	Artikel Nr. Part No.	Qty.	Unit	Beschreibung Descripción	Description Description	Abm. Measur.	Norm Standard
						Drehm. Torque	Schmierstoff Sealant
25	5100021997	1	PC	Aufkleber-Typ Tipo etiqueta autoadhesiva	Type label Autocollant de type		
26	5000222085	1	PC	Aufkleber Symbol Calcomanía símbolo	Label symbol Autocollant symbole		
27	5000213181	1	PC	Aufkleber Logo Calcomanía insigniaipo	Label logo Autocollant logo	40mm	
28	5100016455	1	PC	Aufkleber (ON-OFF) Calcomanía (on-off)	Label (on-off) Autocollant (on-off)		
29	5100018423	1	PC	Aufkleber Calcomanía	Label Autocollant		
30	5000219260	1	PC	Aufkleber Calcománias	Labels Autocollants		
31	5000220000	1	PC	Aufkleber-Warnhinweis Calcomanía-indicación	Instruction label Autocollant avec indication		
32	5000219181	1	PC	Aufkleber Calcománias	Labels Autocollants		
33	5000129784	1	PC	Aufkleber-Schalleistungspegel Etiqueta autoadhesiva-nivel de potencia acúëstica	Decal-sound power level Autocollante-niveau sonore		

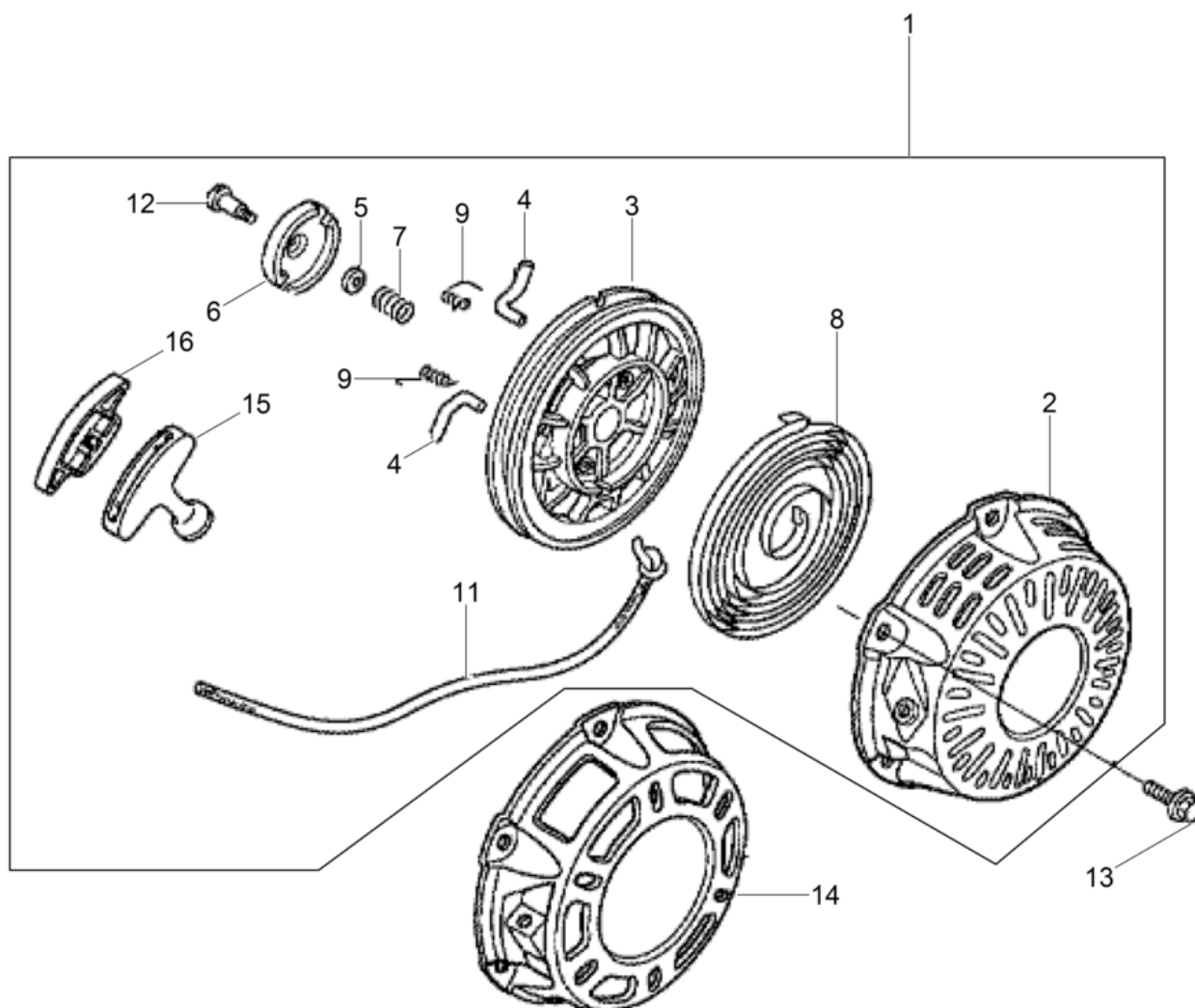

Pos. Ref.	Artikel Nr. Part No.	Qty.	Unit	Beschreibung Descripción	Description Description	Abm. Measur.	Norm Standard
						Drehm. Torque	Schmierstoff Sealant
1	5100005305	1	PC	Seilzugstarter Kpl. US(Schwarz) Arrancador cpl. us (negro)	Starter cpl. us (black) Démarrreur cpl. us (noir)		
1	5100005366	1	PC	Seilzugstarter Kpl. (Rot) Arrancador cpl. (rojo)	Starter cpl. (red) Démarrreur cpl. (rouge)		
1	5100005367	1	PC	Seilzugstarter Kpl. (Schwarz) Arrancador cpl. (negro)	Starter cpl. (black) Démarrreur cpl. (noir)		
1	5100005368	1	PC	Seilzugstarter Kpl. US (Rot) Arrancador cpl. us (rojo)	Starter cpl. us (red) Démarrreur cpl. us (rouge)		
2	5100005307	1	PC	Gehäuse Kpl. (Schwarz) Carcasa cpl. (negro)	Housing cpl. (black) Carter cpl. (noir)		
2	5100005369	1	PC	Gehäuse Kpl. (Rot) Carcasa cpl. (rojo)	Housing cpl. (red) Enveloppe cpl. (rouge)		
3	5100005308	1	PC	Seilscheibe Polea para cuerda	Rope disc Poulie de démarrage		
4	5000160527	2	PC	Ratsche Trinquete	Ratchet Cliquet		
5	5000160748	1	PC	Reibplatte Placa de fricción	Friction plate Plaque à friction		
6	5000160745	1	PC	Führung Guía	Guide Guide		
7	5000160747	1	PC	Reibfeder Resorte de fricción	Friction spring Ressort à friction		
8	5000081777	1	PC	Feder Resorte	Spring Ressort		
9	5000207990	2	PC	Schenkelfeder Resorte	Spring Ressort		
11	5000081781	1	PC	Starterseil Cuerda	Rope Corde		
12	5000207991	1	PC	Schraube Tornillo	Screw Vis		
13	5000158458	3	PC	Flanschbolzen Tornillo de perno	Flange bolt Vis de boulon	6 x 10	
15	5100005309	1	PC	Startergriff US Empuñadura del starter us	Starter handle us Poignée du lanceur us		
15	5100005413	1	PC	Startergriff Empuñadura del starter	Starter handle Poignée du lanceur		
16	5100005310	1	PC	Abdeckung Cubierta	Covering Couverture		

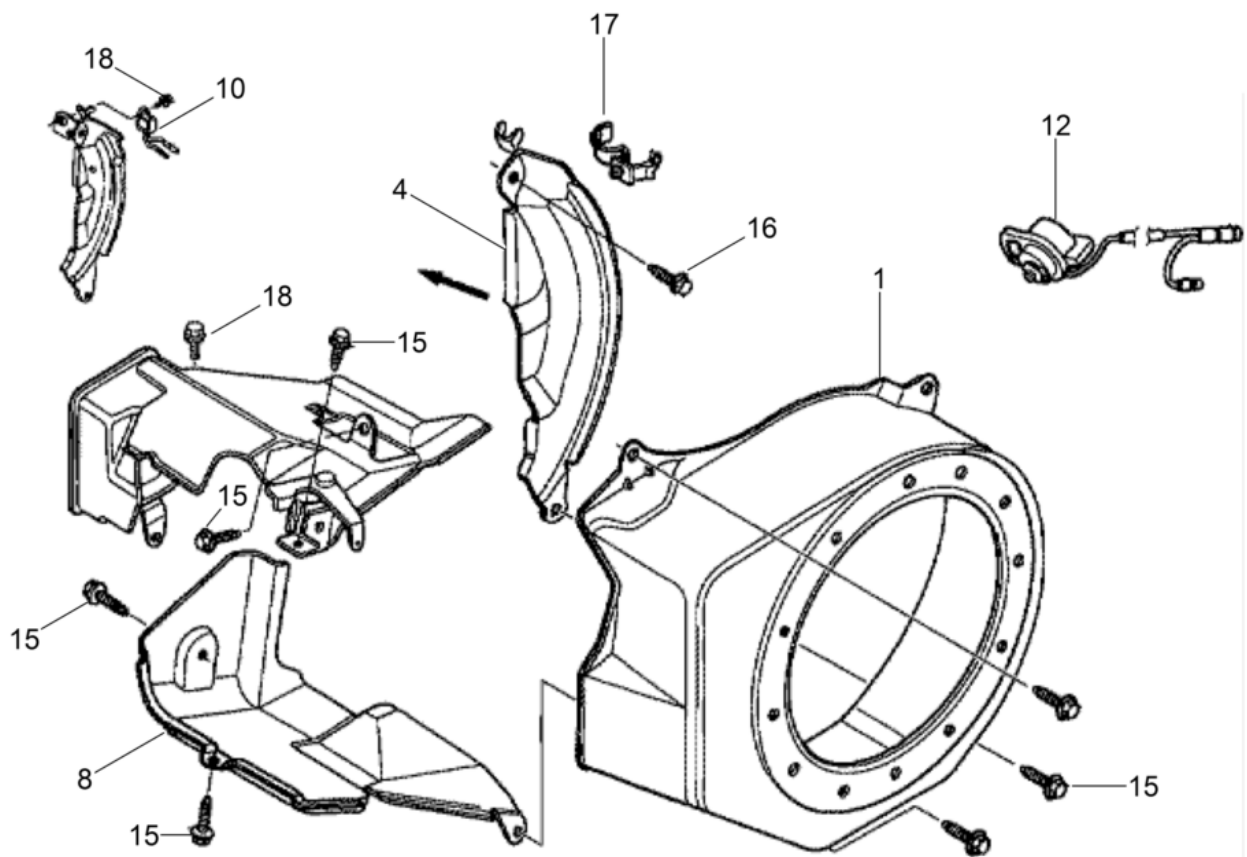

Pos. Ref.	Artikel Nr. Part No.	Qty.	Unit	Beschreibung Descripcion	Description Description	Abm. Measur.	Norm Standard
						Drehm. Torque	Schmierstoff Sealant
1	5100005311	1	PC	Gebeläseabdeckung Kpl. (Schwarz) Tapa de ventilador cpl. (negro)	Fan hood cpl. (black) Couvercle du sys. de vent. cpl		
1	5100005354	1	PC	Gebeläseabdeckung Kpl. Tapa de ventilador cpl.	Fan hood cpl. Couvercle du sys. de vent. cpl		
4	5100005312	1	PC	Abdeckung Cubierta	Covering Couverture		
8	5100005414	1	PC	Halterung Kpl. Soporte cpl.	Bracket cpl. Équerre cpl.		
10	5100003471	1	PC	Ölsensor Alerta de aceite	Oil sensor Alerte d'huile		
12	5000162682	1	PC	Schalter Kpl. Interruptor compl.	Switch assembly Interrupteur compl.		
15	5000053990	6	PC	Schraube Tornillo	Screw Vis	M6 x 12 10Nm/7ft.lbs	
16	5000071055	1	PC	Schraube Tornillo	Screw Vis	M6 x 20 10Nm/7ft.lbs	
17	5000153138	1	PC	Schelle Abrazadera	Clamp Collier		
18	5000162077	1	PC	Flanschschraube Tornillo de brida	Flange screw Vis de bride		

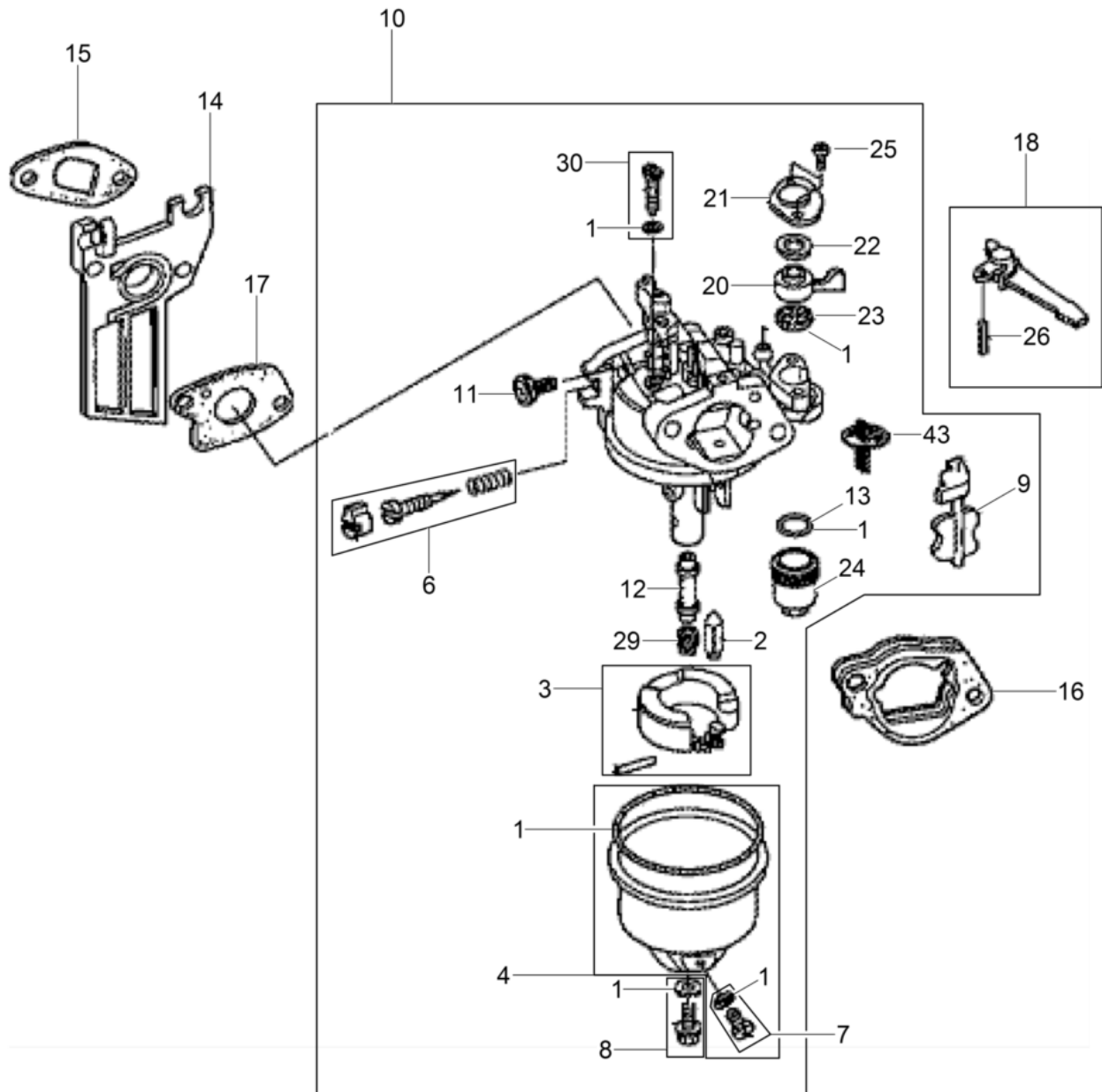

Pos. Ref.	Artikel Nr. Part No.	Qty.	Unit	Beschreibung Descripción	Description Description	Abm. Measur.	Norm Standard
						Drehm. Torque	Schmierstoff Sealant
1	5000072781	1	PC	Dichtungssatz Juego de juntas	Set-gaskets Jeu de joints		
2	5000071022	1	PC	Schwimmernadel Kpl. Válvula de flotador	Set-float valve Pointeau du carburateur		
3	5000209764	1	PC	Schwimmer Kpl. Juego de flotador	Set-carburetor float Jeu de flotteur		
4	5100005314	1	PC	Schwimmergehäuse Cámara de flotador	Float housing Cuve à niveau constant		
6	5000089286	1	PC	Gewindestift Tornillo	Setscrew Vis		
7	5200000430	1	PC	Schraube Mit Scheibe Tornillo con arandela	Screw w/washer Vis avec rondelle		
8	5200000431	1	PC	Schraube Mit Scheibe Tornillo con arandela	Screw w/washer Vis avec rondelle		
9	5100005415	1	PC	Staterklappe Válvula de mariposa	Starter flap Volet de démarrage		
10	5000406637	1	PC	Vergaser Kpl. Carburador compl.	Carburetor cpl. Carburateur compl.		
11	5000071018	1	PC	Anschlagschraube Tornillo de tope	Throttle stop screw Vis		
12	5100009310	1	PC	Hauptdüse Chicler principal	Main jet Gicleur principal		
13	5000125839	1	PC	O-Ring Anillo-o	O-ring Joint torique		
14	5100005416	1	PC	Isolator Aislador	Isolator Isolateur		
15	5000082009	1	PC	Dichtung Junta	Gasket Joint		
16	5000071015	1	PC	Distanzstück Espaciador	Spacer Pièce d'écartement		
17	5000081762	1	PC	Dichtung Junta	Gasket Joint		
18	5000071013	1	PC	Chokehebel Palanca estranguladora	Choke control lever Levier d'étrangleur		
20	5000150266	1	PC	Kraftstoffhahn Palanca	Fuel valve lever Levier		
21	5000073269	1	PC	Platte Placa	Plate Plaque		
22	5000073270	1	PC	Federscheibe Arandela elástica	Spring washer Rondelle à ressort		
23	5000073272	1	PC	Dichtung Junta	Gasket Joint		
24	5000071023	1	PC	Kraftstofffilter Filtro de combustible	Fuel filter Filtre à carburant		
25	5100005317	2	PC	Kegelkopfschraube 3X6 Tornillo	Screw Vis	3x6	
26	5000071014	1	PC	Stift Pasador	Pin Goupille	2 x 12	
29	5000207672	1	PC	Hauptdüse Chicler principal	Main jet Gicleur principal	62	
29	5100005417	1	PC	Hauptdüse Chicler principal	Main jet Gicleur prinzipal	65	
29	5100005417	1	PC	Hauptdüse Chicler principal	Main jet Gicleur prinzipal	65	
30	5000071016	1	PC	Leerlaufdüse Chicler ralenti	Pilot jet Gicleur de ralenti	35	

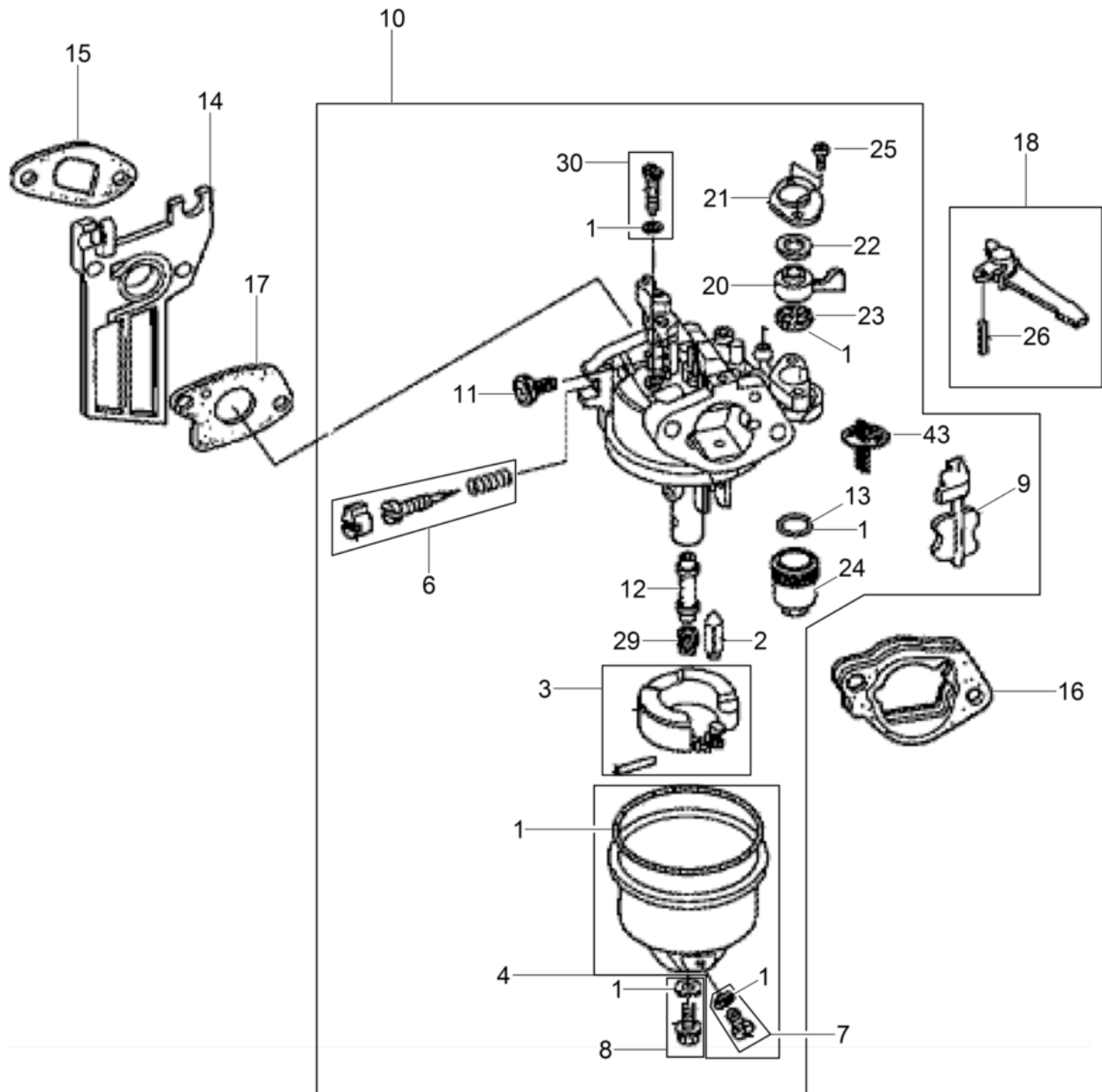

VP1550Aw**Vergaser
Carburetor
Carburador
Carburateur**

Pos. Ref.	Artikel Nr. Part No.	Qty.	Unit	Beschreibung Descripcion	Description Description	Abm. Measurem.	Norm Standard
						Drehm. Torque	Schmierstoff Sealant
43	5100000396	1	PC	Filter Filtro	Filter Filtre		



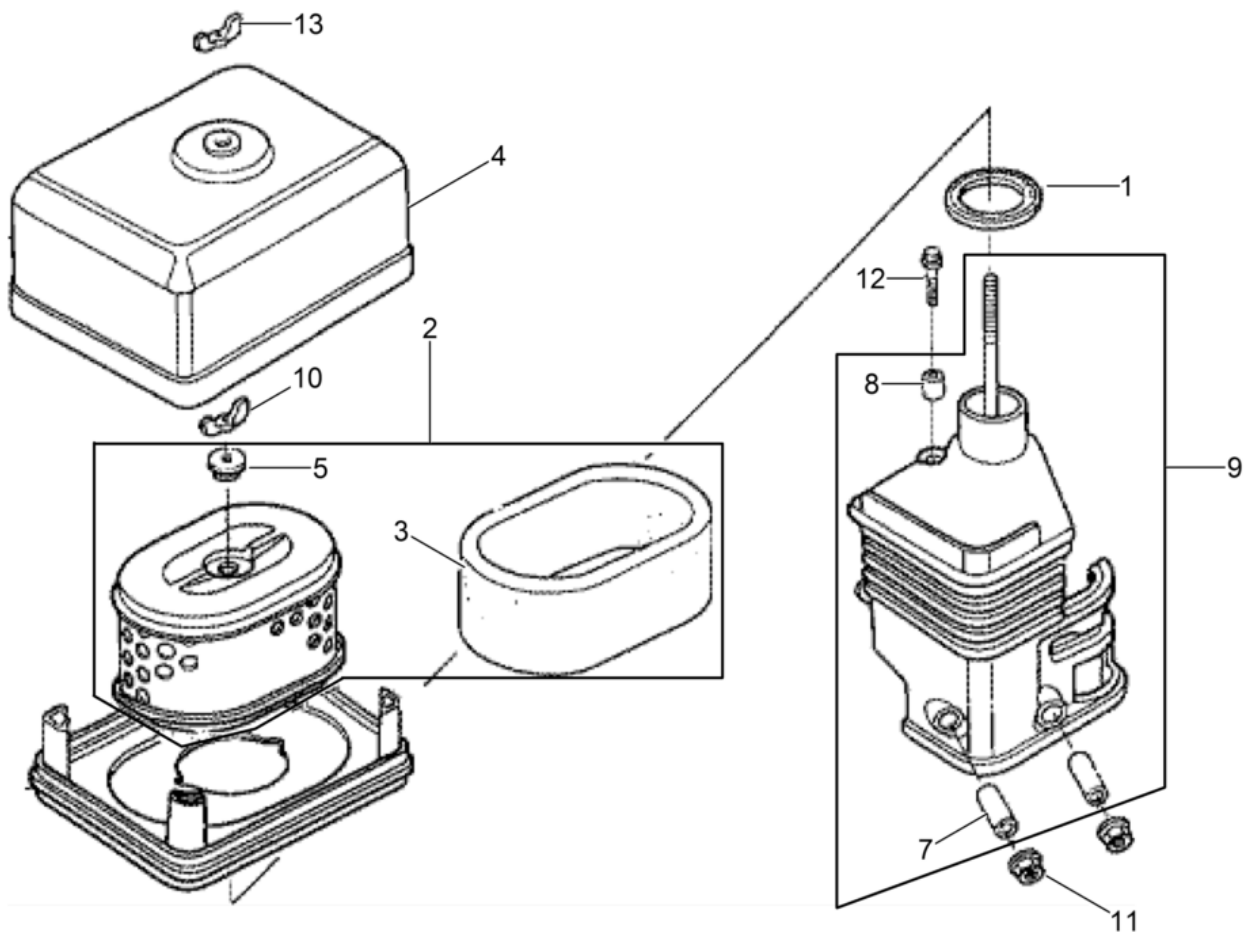

Pos. Ref.	Artikel Nr. Part No.	Qty.	Unit	Beschreibung Descripcion	Description Description	Abm. Measur.	Norm Standard
						Drehm. Torque	Schmierstoff Sealant
1	5000071032	1	PC	Dichtung Junta	Gasket Joint		
2	5100005319	1	PC	Luftfiltereinsatz Elemento-filtro	Air cleaner element Elément filtrant		
3	5000217459	1	PC	Luftfiltereinsatz Inserto para filtro de aire	Air filter insert Garniture filtre à air		
4	5100005419	1	PC	Filterdeckel Tapa de filtro	Filter cover Couvercle du filtre		
4	5100019660	1	PC	Luftfilterdeckel Tapa-filtro del aire	Air cleaner cover Couvercle-filtre à air		
5	5000072343	1	PC	Tülle Ojal	Grommet Passe-fil		
7	5000081746	2	PC	Hülse Collar	Sleeve Douille		
8	5000071035	1	PC	Hülse Manguito	Sleeve Douille		
9	5100005420	1	PC	Filterkonsole Consola del filtro	Filter bracket Console de filtre		
10	5000071621	1	PC	Flügelmutter Tuerca mariposa	Wing nut Ecrou papillon	M6	
11	5000071056	2	PC	Mutter Tuerca	Nut Ecrou	M6	
12	5100003499	1	PC	Flanschschraube 6X20 Tornillo de brida	Flange screw Vis de bride	6x20	
13	5100005421	1	PC	Mutter Tuerca	Nut Ecrou		

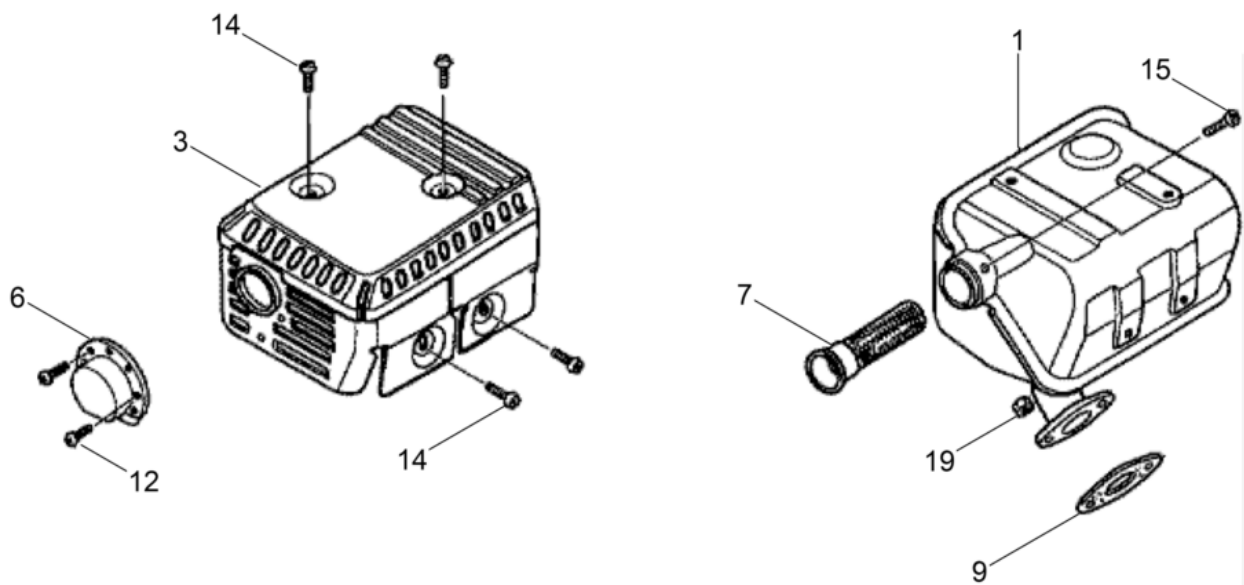

Pos. Ref.	Artikel Nr. Part No.	Qty.	Unit	Beschreibung Descripción	Description Description	Abm. Measur.	Norm Standard
						Drehm. Torque	Schmierstoff Sealant
1	5100005364	1	PC	Schalldämpfer Kpl. Silenciador cpl.	Muffler cpl. Silencieux cpl.		
3	5000406646	1	PC	Schutz Protector	Guard Protection		
6	5000153130	1	PC	Führung Guía	Guide Guide		
7	5000071075	1	PC	Funkenfänger Parachispas	Spark arrester Pare-étincelles		
9	5000216516	1	PC	Dichtung Junta de estanqueidad	Gasket Garniture		
12	5000209783	2	PC	Schneidschraube Tornillo autorroscante	Self-tapping screw Vis autotaraudeuse	4 x 8	
14	5000071070	4	PC	Schraube Tornillo	Screw Vis	M5 x 8	
15	5000150916	1	PC	Schraube Tornillo	Screw Vis	M4x6	
19	5100003492	2	PC	Sechskantmutter M8 Tuerca hexagonal	Hexagon nut Écrou hexagonal	M8	

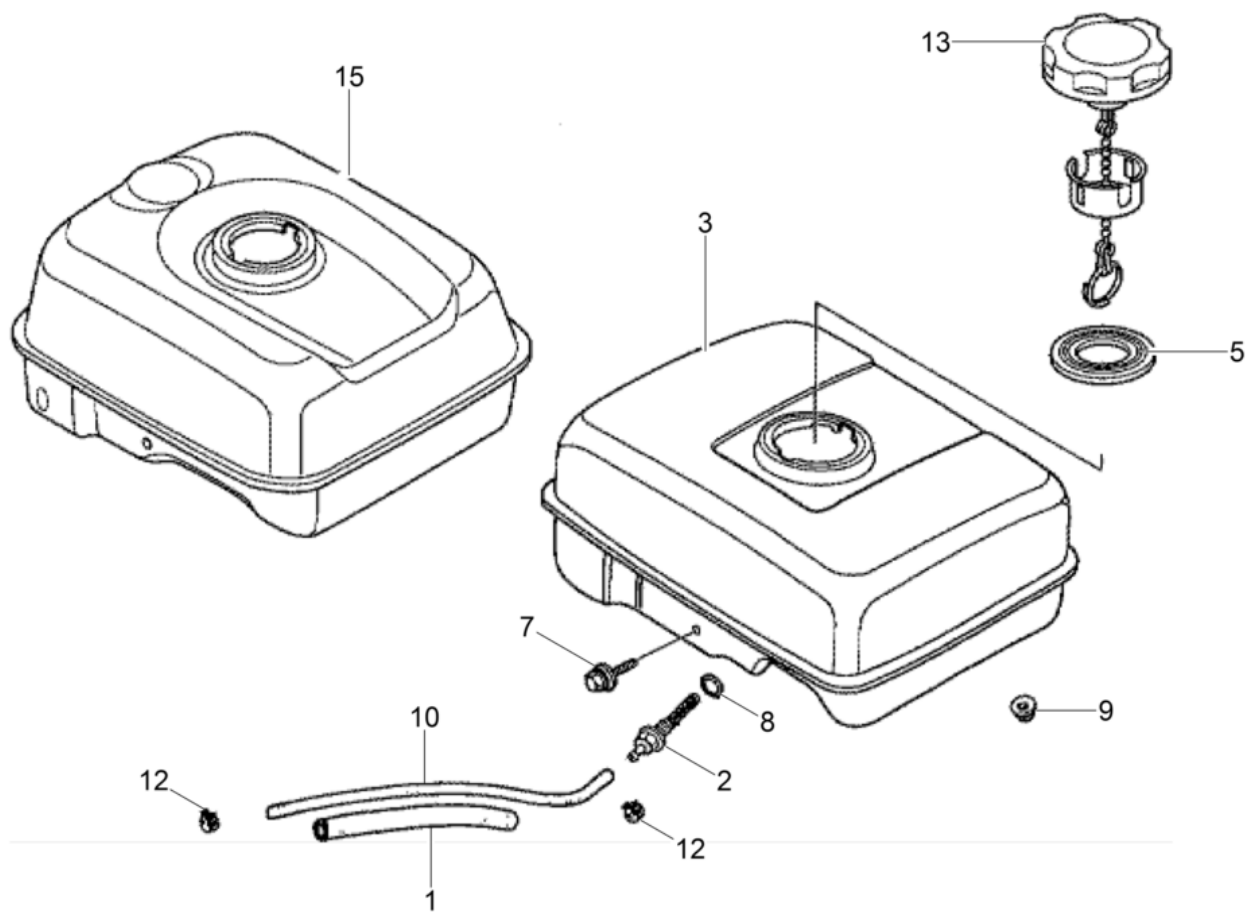

Pos. Ref.	Artikel Nr. Part No.	Qty.	Unit	Beschreibung Descripción	Description Description	Abm. Measur.	Norm Standard
						Drehm. Torque	Schmierstoff Sealant
1	5000081764	1	PC	Schlauchstück Manguera	Protective hose Tuyau		
2	5100000395	1	PC	Verbindungsstück Conexión	Connection Connexion		
3	5000082013	1	PC	Kraftstofftank Tanque de combustible	Fuel tank Réservoir de carburant		
3	5000110765	1	PC	Kraftstofftank Depósito de combustible	Fuel tank Réservoir à essence		
5	5000209770	1	PC	Dichtung Junta de estanqueidad	Gasket Garniture		
7	5000209771	1	PC	Flanschbolzen Tornillo de perno	Flange bolt Vis de boulon	6x29	
8	5000208616	1	PC	O-Ring Anillo-o	O-ring Joint torique	14M	
9	5000071056	2	PC	Mutter Tuerca	Nut Ecrou	M6	
10	5100005325	1	PC	Kraftstoffschlauch 4,5X145 Manguera de combustible	Fuel hose Tuyau à essence	4,5x145	
12	5000208617	2	PC	Rohrschelle Abrazadera	Clamp Agrafe		
13	5000213409	1	PC	Schwungrad Volante	Flywheel Volant		
13	5100005357	1	PC	Tankdeckel Kpl. Tapa de tanque cpl.	Tank cover cpl. Couvercle du reservoir cpl.		
15	5100005323	1	PC	Kraftstofftank Kpl. Tanque de combustible cpl.	Fuel tank cpl. Réservoir de carburant cpl.		

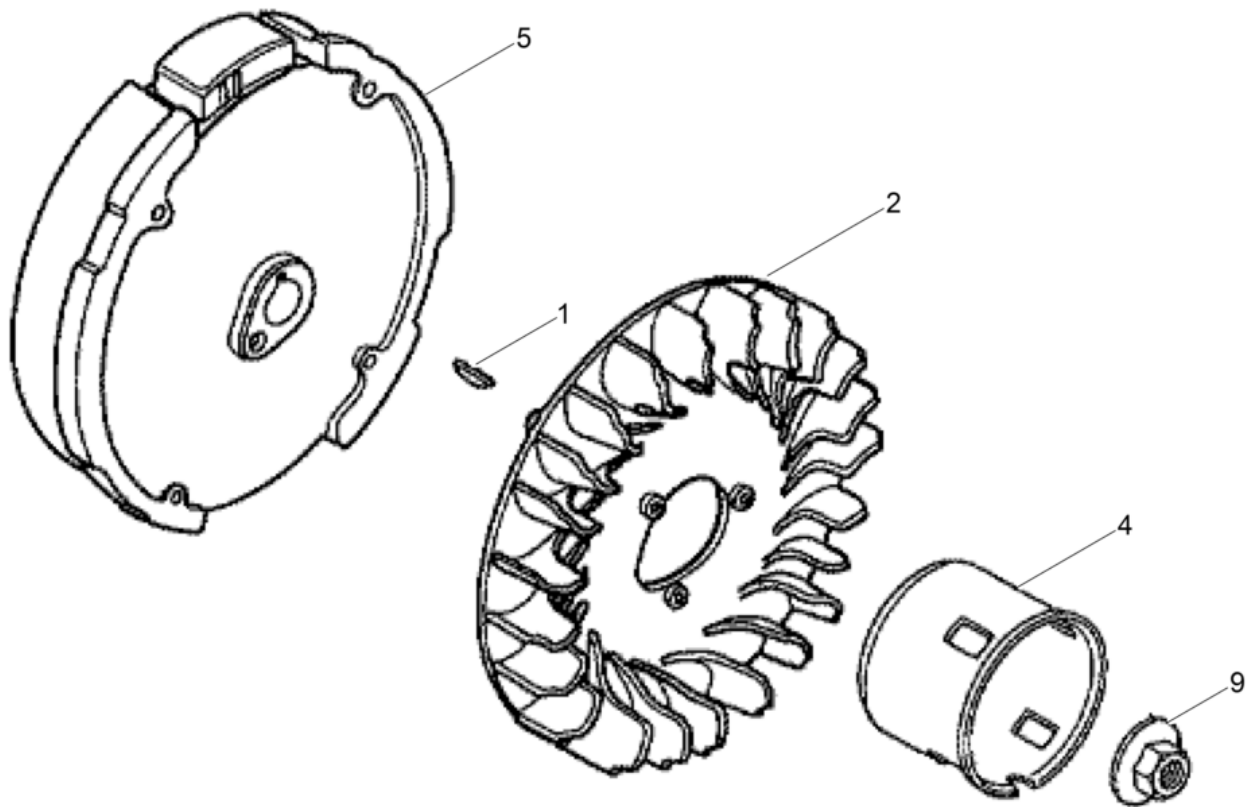

Pos. Ref.	Artikel Nr. Part No.	Qty.	Unit	Beschreibung Description	Description Description	Abm. Measur.	Norm Standard
						Drehm. Torque	Schmierstoff Sealant
1	5000068967	1	PC	Keil Chaveta woodruff	Woodruff key Clavette woodruff	25 x 18	
2	5000071652	1	PC	Lüfterrad Ventilador	Fan Ventilateur		
4	5000210396	1	PC	Seilscheibe Polea	Pulley Poulie		
5	5100005422	1	PC	Schwungrad Kpl. Volante cpl.	Fly wheel cpl. Volant cpl.		
9	5000162686	1	PC	Mutter Tuerca	Nut Écrou	M14	

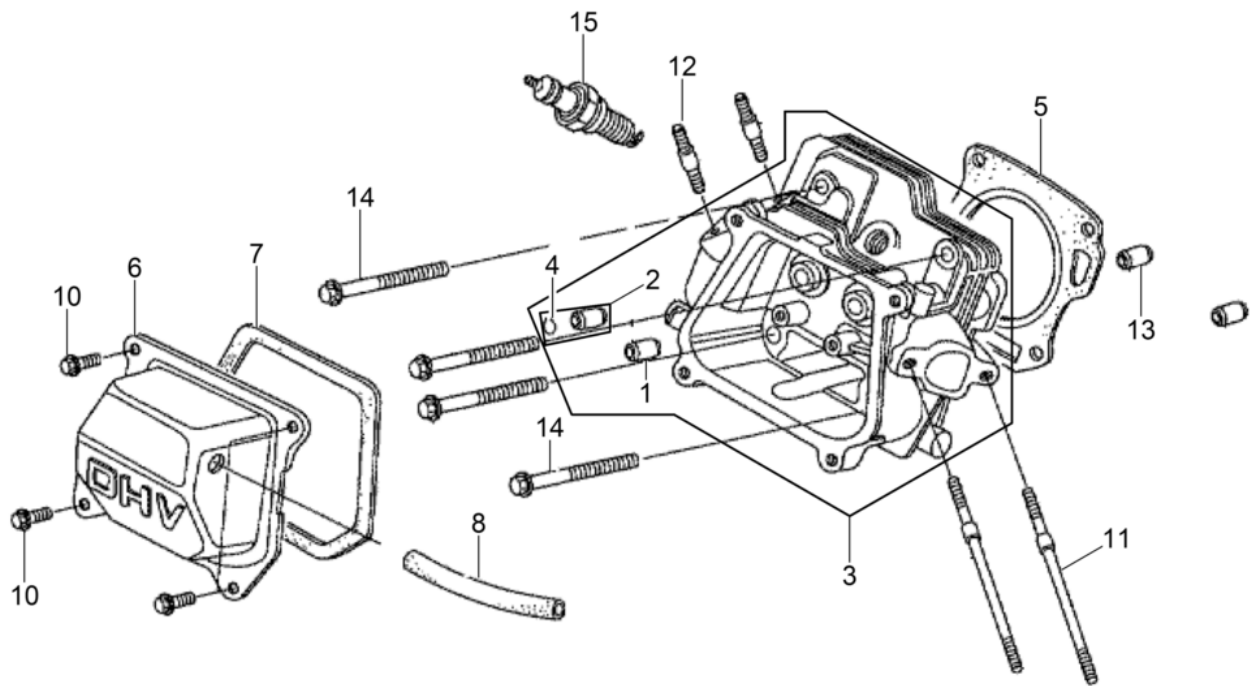

Pos. Ref.	Artikel Nr. Part No.	Qty.	Unit	Beschreibung Descripción	Description Description	Abm. Measur.	Norm Standard
						Drehm. Torque	Schmierstoff Sealant
1	5000070945	1	PC	Ventilführung Guía de válvula	Valve guide Guide de soupape		
2	5000070944	1	PC	Ventilführung Guía de válvula	Valve guide Guide de soupape		
3	5100005423	1	PC	Zylinderkopf Kpl. Culata cpl.	Cylinder head cpl. Culasse cpl.		
4	5000081744	1	PC	Sicherungsring Anillo de retención	Retaining ring Bague d'arrêt		
5	5100005329	1	PC	Zylinderkopfdichtung Junta de culata del cilindro	Cylinder head gasket Joint de culasse de cylindre		
6	5100005424	1	PC	Deckel Kpl. Tapa cpl.	Cover cpl. Couvercle cpl.		
7	5000070942	1	PC	Dichtung Junta	Gasket Joint		
8	5000081761	1	PC	Entlüftungsrohr Tubo respiradero	Breather tube Tube reniflard		
10	5000053990	4	PC	Schraube Tornillo	Screw Vis	M6 x 12 10Nm/7ft.lbs	
11	5000073263	2	PC	Gewindebolzen Perno prisionero	Stud Boulon	M6 x 109	
12	5000070948	2	PC	Gewindebolzen Perno prisionero	Stud Boulon	M8 x 32	
13	5000070950	2	PC	Passtift Espiga	Dowel pin Cheville		
14	5000213398	4	PC	Flanschschraube Tornillo de brida	Flange screw Vis de bride	M 8x60	
15	5000150914	1	PC	Zündkerze Bujía	Spark plug Bougie		

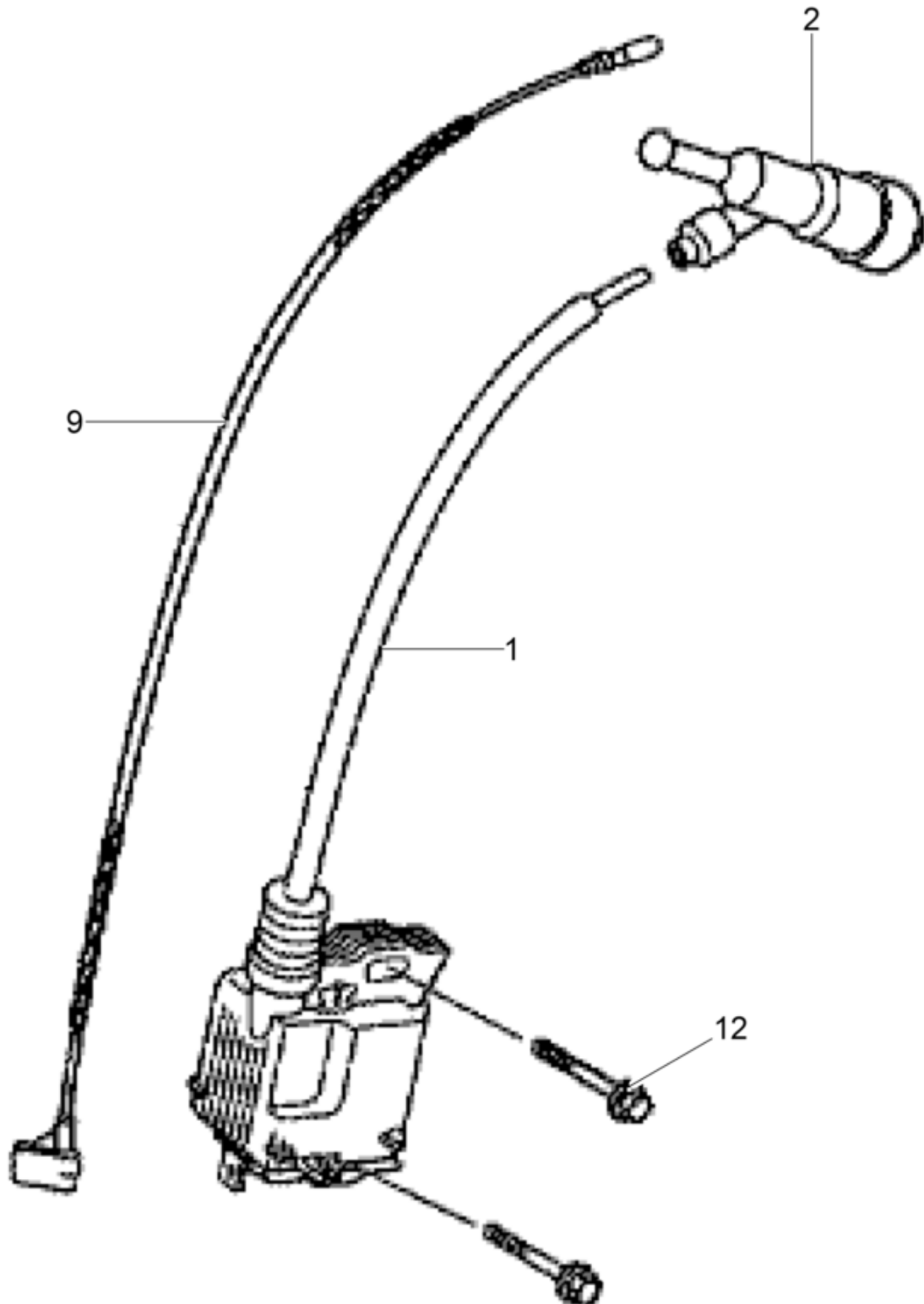

Pos. Ref.	Artikel Nr. Part No.	Qty.	Unit	Beschreibung Descripcion	Description Description	Abm. Measur.	Norm Standard
						Drehm. Torque	Schmierstoff Sealant
1	5100003455	1	PC	Zündspule Kpl. Bobina de encendido cpl.	Ignition coil cpl. Bobine d'allumage cpl.		
2	5000162680	1	PC	Zündkerzenstecker Enchufe de bujía	Spark plug terminal cap Porte bougies		
9	5000081663	1	PC	Kurzschlusskabel Cable de cortocircuito	Short circuit cable Câble courti-circuit		
12	5000081737	2	PC	Schraube Tornillo	Screw Vis	M6 x 25	

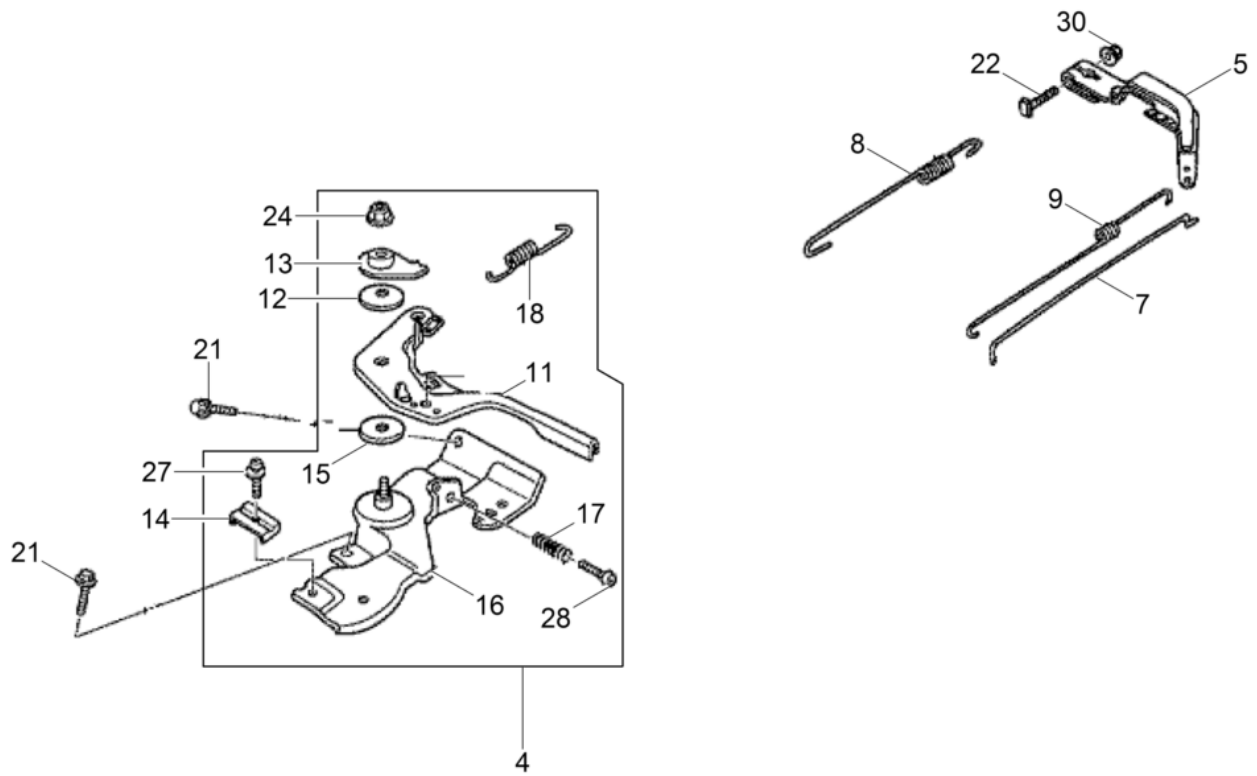

Pos. Ref.	Artikel Nr. Part No.	Qty.	Unit	Beschreibung Descripción	Description Description	Abm. Measur.	Norm Standard
						Drehm. Torque	Schmierstoff Sealant
4	5100009311	1	PC	Regler Kpl. US Regulador cpl. us	Governor cpl. us Régulateur cpl. us		
4	5100009312	1	PC	Regler Kpl. Regulador cpl.	Governor cpl. Régulateur cpl.		
5	5100005425	1	PC	Regulierhebel Palanca reguladora	Governor lever Levier régulateur		
7	5100005332	1	PC	Reglerstange Varillaje de regulación	Governor rod Tige de régulateur		
8	5000406658	1	PC	Reglerfeder Resorte del regulador	Governor spring Ressort régulateur		
9	5100005427	1	PC	Rückholfeder Resorte de retorno	Return spring Ressort de rappel		
11	5100005333	1	PC	Reglerhebel Palanca de regulador	Governor lever Levier régulateur		
12	5000071058	1	PC	Feder Resorte	Spring Ressort		
13	5000071057	1	PC	Scheibe Arandela	Washer Rondelle		
14	5000071062	1	PC	Klemme Soporte cable	Cable holder Attache		
15	5000071064	1	PC	Distanzstück Espaciador	Spacer Pièce d'écartement		
16	5100005363	1	PC	Halterung Kpl. Soporte cpl.	Bracket cpl. Équerre cpl.		
17	5000054088	1	PC	Feder Resorte de ajuste	Adjusting spring Ressort d'ajustage		
18	5000071667	1	PC	Feder Resorte	Spring Ressort		
21	5000053990	2	PC	Schraube Tornillo	Screw Vis	M6 x 12 10Nm/7ft.lbs	
22	5000068966	1	PC	Schraube Tornillo	Screw Vis		
24	5000072782	1	PC	Sicherungsmutter Contratuerca	Locknut Contre-écrou	M6	
27	5000110112	1	PC	Schraube Tornillo	Screw Vis	5 x 16	
28	5000081990	1	PC	Schraube Tornillo	Screw Vis	M5 x 25	
30	5000071056	1	PC	Mutter Tuerca	Nut Ecrou	M6	

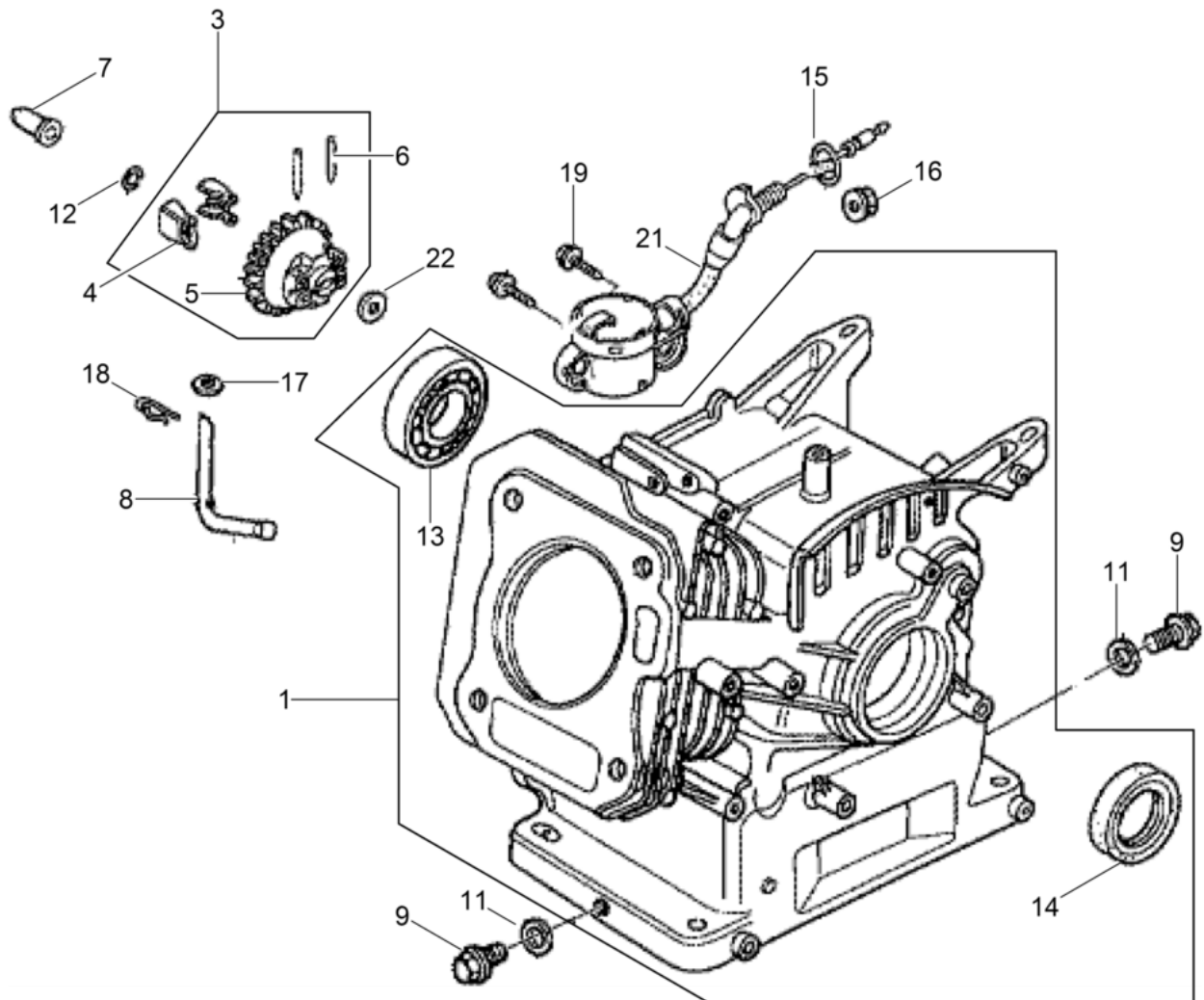

Pos. Ref.	Artikel Nr. Part No.	Qty.	Unit	Beschreibung Descripción	Description Description	Abm. Measur.	Norm Standard
						Drehm. Torque	Schmierstoff Sealant
1	5200006492	1	PC	Zylinder Kpl. Cilindro compl.	Cylinder cpl. Cylindre compl.		
3	5100005429	1	PC	Regler Kpl. Regulador cpl.	Governor cpl. Régulateur cpl.		
4	5100005430	2	PC	Gewicht Peso	Weight Poids		
5	5100005431	1	PC	Halter Soporte	Bracket Équerre		
6	5000156689	2	PC	Stift Espiga	Pin Goupille		
7	5100005432	1	PC	Reglerstift Pasador del regulador	Governor pin Pointe de regulateur		
8	5100005433	1	PC	Regler Regulador	Governor Régulateur		
9	5000070964	2	PC	Verschlusschraube Tapón roscado	Plug (threaded) Bouchon		
11	5000070963	2	PC	Scheibe Arandela	Washer Rondelle		
12	5000081615	1	PC	Sicherungsring Anillo de retención	Retaining ring Bague d'arrêt		
13	5000082018	1	PC	Lager Rodamiento	Bearing Roulement		
14	5000217464	1	PC	Wellendichtring Empaque de aceite	Oil seal Joint d'huile	25x41x6	
15	5000208616	1	PC	O-Ring Anillo-o	O-ring Joint torique	14M	
16	5000072332	1	PC	Flanschmutter Tuerca de reborde	Flange nut Ecrou de bride	M10	
17	5000071639	1	PC	Scheibe Arandela	Washer Rondelle	6M	
18	5000054033	1	PC	Stift Pasador	Pin Goupille		
19	5100003498	2	PC	Flanschschraube 6X12 Tornillo de brida	Flange screw Vis de bride	6x12	
21	5000216513	1	PC	Ölwarnschalter Modulo-interruptor	Oil alert switch cpl. Module-contacteur		
22	5000071639	1	PC	Scheibe Arandela	Washer Rondelle	6M	

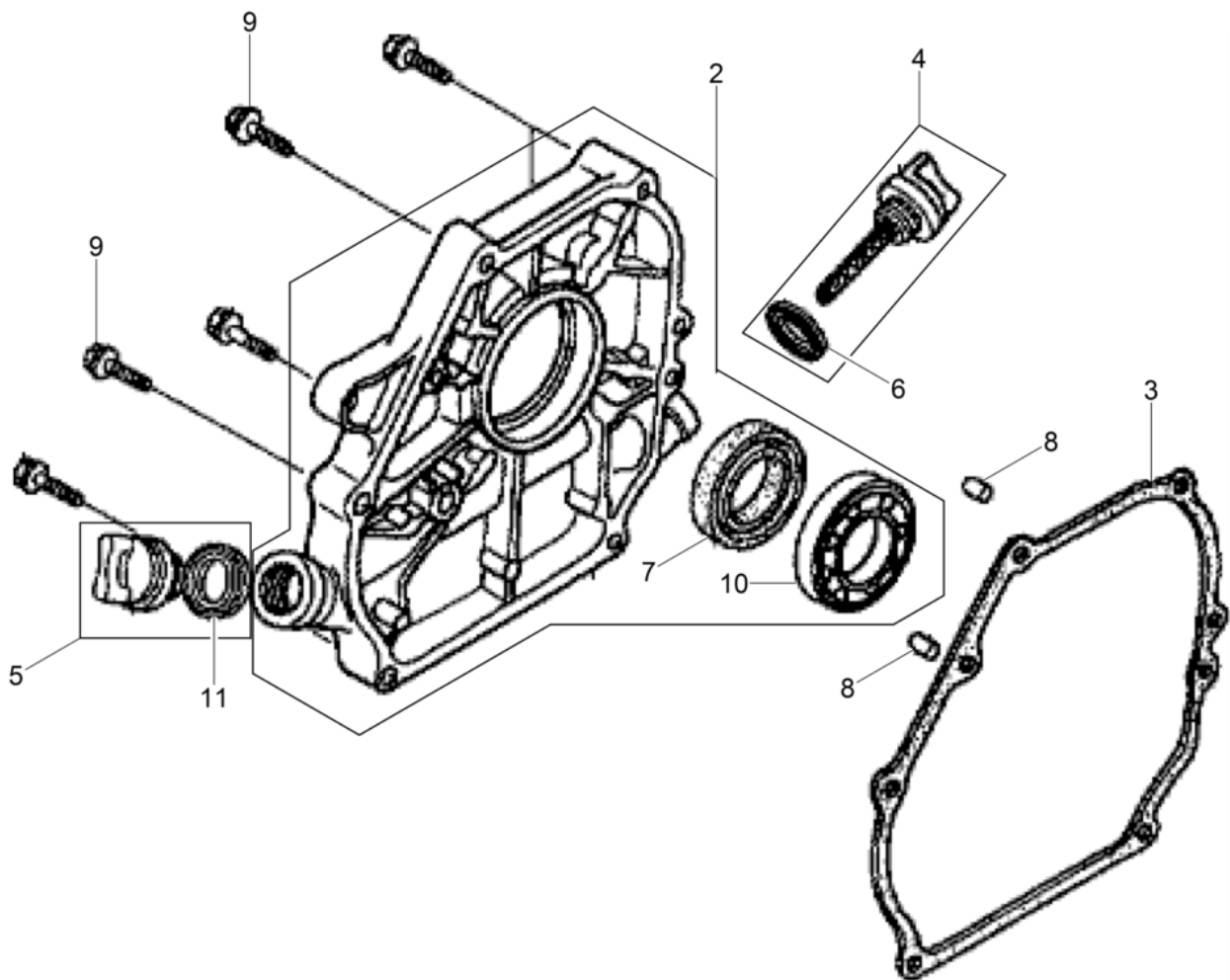

Pos. Ref.	Artikel Nr. Part No.	Qty.	Unit	Beschreibung Description	Description Description	Abm. Measur.	Norm Standard
						Drehm. Torque	Schmierstoff Sealant
2	5100005434	1	PC	Kurbelgehäusedeckel Kpl. Tapa del cárter cpl.	Crankcase cover cpl. Couvercle de carter cpl.		
3	5100009314	1	PC	Dichtung Junta	Gasket Joint		
4	5000162645	1	PC	Peilstab Kpl. Indicador del nivel de aceite compl.	Dipstick assembly Réglette-jauge compl.		
5	5000162646	1	PC	Kappe-Ölfüller Llenador de aceite	Oil filler cap Remplisseur d'huile		
6	5000162647	1	PC	Dichtung Junta de estanqueidad	Gasket Garniture		
7	5000053983	1	PC	Wellendichtring Sello del eje	Shaft seal Bague d'étanchéité		
8	5000053995	2	PC	Passstift Espiga	Dowel pin Cheville	A8 x 14	
9	5100003504	6	PC	Flanschschraube 8X32 Tornillo de brida	Flange screw Vis de bride	8x32	
10	5100003510	1	PC	Radialkugellager 6205 Rodamiento de bolas	Grooved ball bearing Roulement à billes		
11	5000162647	1	PC	Dichtung Junta de estanqueidad	Gasket Garniture		

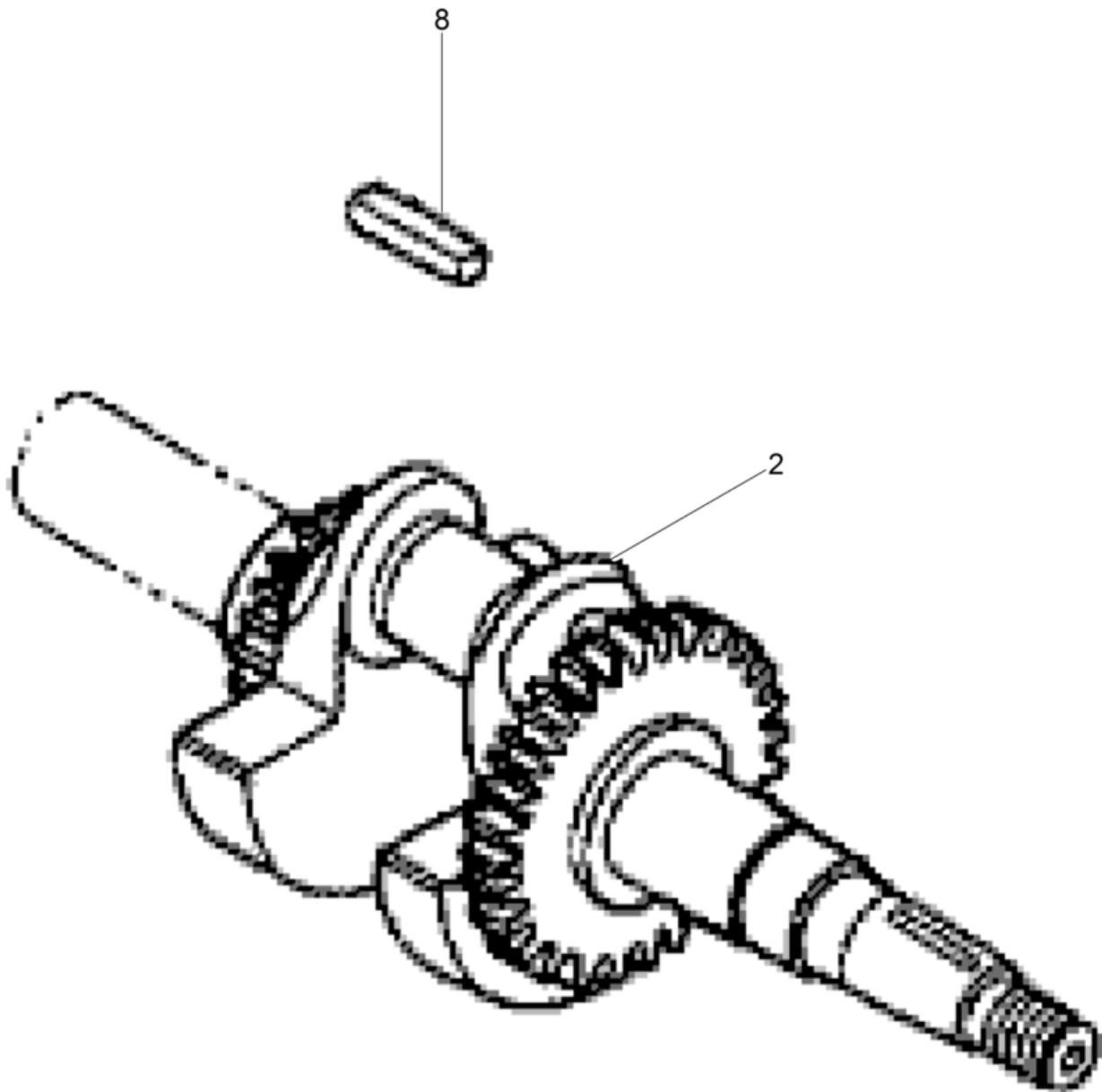

Pos. Ref.	Artikel Nr. Part No.	Qty.	Unit	Beschreibung Descripcion	Description Description	Abm. Measur.	Norm Standard
						Drehm. Torque	Schmierstoff Sealant
2	5100005359	1	PC	Kurbelwelle Kpl. Cigueñal cpl.	Crankshaft cpl. Vilebrequin cpl.		
2	5000217529	1	PC	Radialkugellager Rodamiento a bolas	Ball bearing Roulement à billes		
2	5100003485	1	PC	Radialkugellager 6205 Rodamiento de bolas	Grooved ball bearing Roulement à billes		
8	5000070999	1	PC	Passfeder Chaveta	Fitting key Clavette	4,78 x 38	

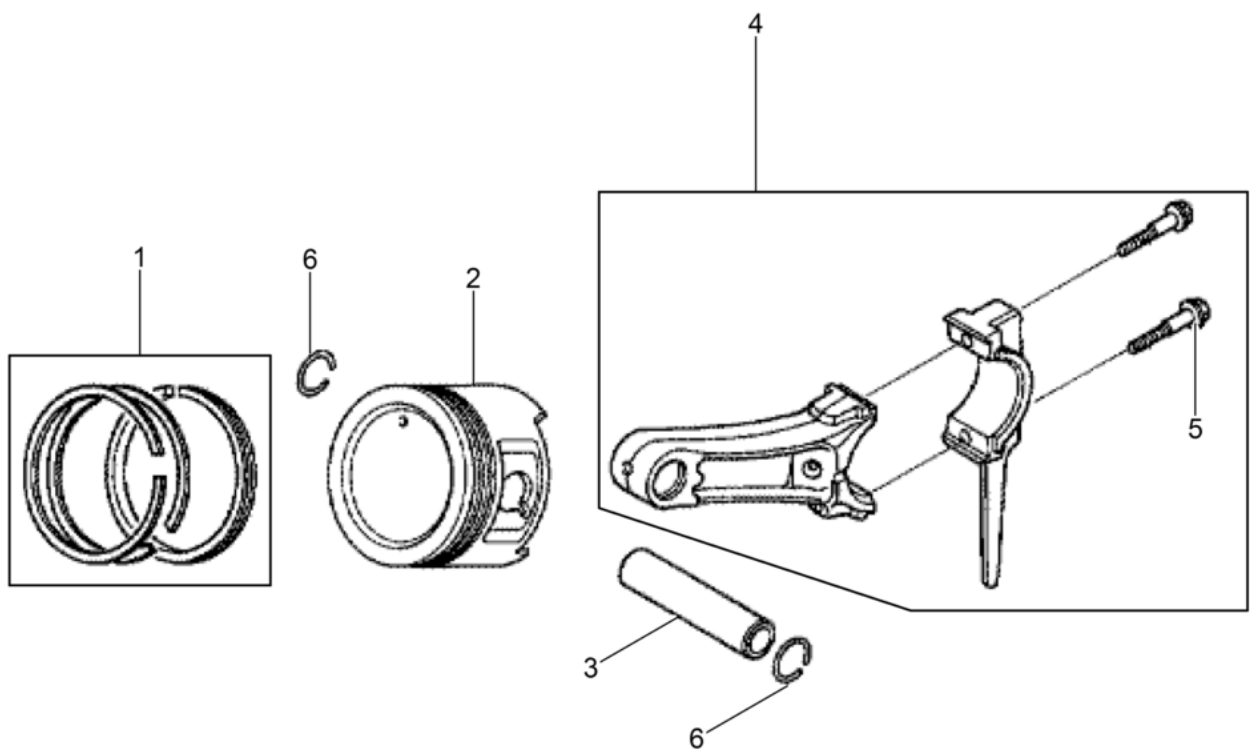

Pos. Ref.	Artikel Nr. Part No.	Qty.	Unit	Beschreibung Descripción	Description Description	Abm. Measur.	Norm Standard
						Drehm. Torque	Schmierstoff Sealant
1	5100005355	1	PC	Kolbenringsatz Juego de aros de pistón	Set of piston rings Jeu de bagues de piston		
1	5100005435	1	PC	Kolbenringsatz Juego de aros de pistón	Set of piston rings Jeu de segments de piston		
1	5000213334	1	PC	Kolbenringsatz Juego de anillos	Piston ring set Jeu de segments	+0,25 mm	
1	5000213335	1	PC	Kolbenringsatz Juego de anillos	Piston ring set Jeu de segments	+0,50 mm	
2	5100005436	1	PC	Kolben Pistón	Piston Piston		
2	5100019661	1	PC	Kolben Pistón	Piston Piston	0,25	
2	5100019662	1	PC	Kolben Pistón	Piston Piston	0,50	
3	5100005348	1	PC	Kolbenbolzen Perno de pistón	Piston pin Axe de piston		
4	5200006505	1	PC	Pleuel Kpl. Biela compl.	Connecting rod cpl. Bielle compl.		
5	5100005438	2	PC	Schraube Tornillo	Screw Vis	6x34,4	
6	5000081994	2	PC	Drahtsprengring Anillo de retención	Retaining ring Anneau de retenue		

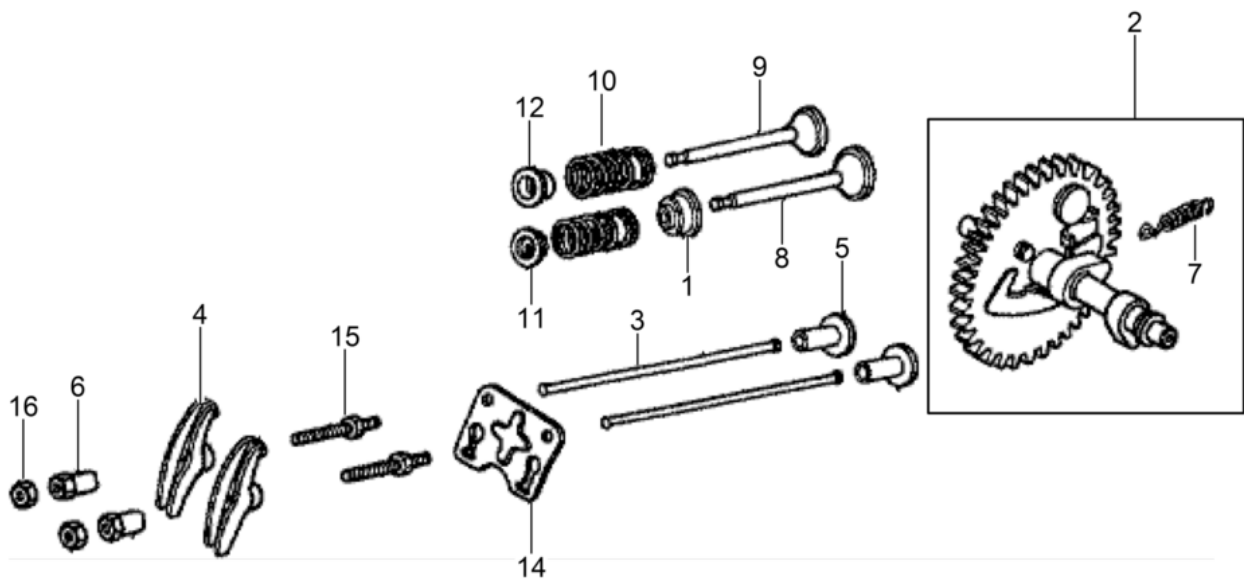

Pos. Ref.	Artikel Nr. Part No.	Qty.	Unit	Beschreibung Descripción	Description Description	Abm. Measur.	Norm Standard
						Drehm. Torque	Schmierstoff Sealant
1	5100005349	1	PC	Dichtung Junta	Gasket Joint		
2	5100005439	1	PC	Nockenwelle Kpl. Arbol de levas cpl.	Camshaft cpl. Arbre à cames cpl.		
3	5100005440	2	PC	Schubstange Varilla de empuje	Push rod Pousoir		
4	5000070986	2	PC	Kipphebel Balancín	Rocker arm Culbuteur		
5	5000070990	2	PC	Ventilstößel Levantaválvula	Valve tappet Pousoir		
6	5000070985	2	PC	Einstellmutter Espaciador	Rocker arm pivot Pivot		
7	5000151028	1	PC	Feder Resorte	Spring Ressort		
8	5100005441	1	PC	Einlassventil Válvula de admisión	Intake valve Soupape d'admission		
9	5100005442	1	PC	Auslassventil Válvula de escape	Outlet valve Soupape d'échappement		
10	5000081760	2	PC	Feder Resorte	Spring Ressort		
11	5000070996	1	PC	Halte Soporte	Holder Attache		
12	5000070996	1	PC	Halte Soporte	Holder Attache		
14	5100005443	1	PC	Führungsblech Chapa de guía	Guide plate Tôle de guidage		
15	5000072778	2	PC	Gewindebolzen Perno prisionero	Stud Boulon	8	
16	5000070984	2	PC	Sechskantmutter Contratuerca	Locknut Contre-écrou	1/4-28in	

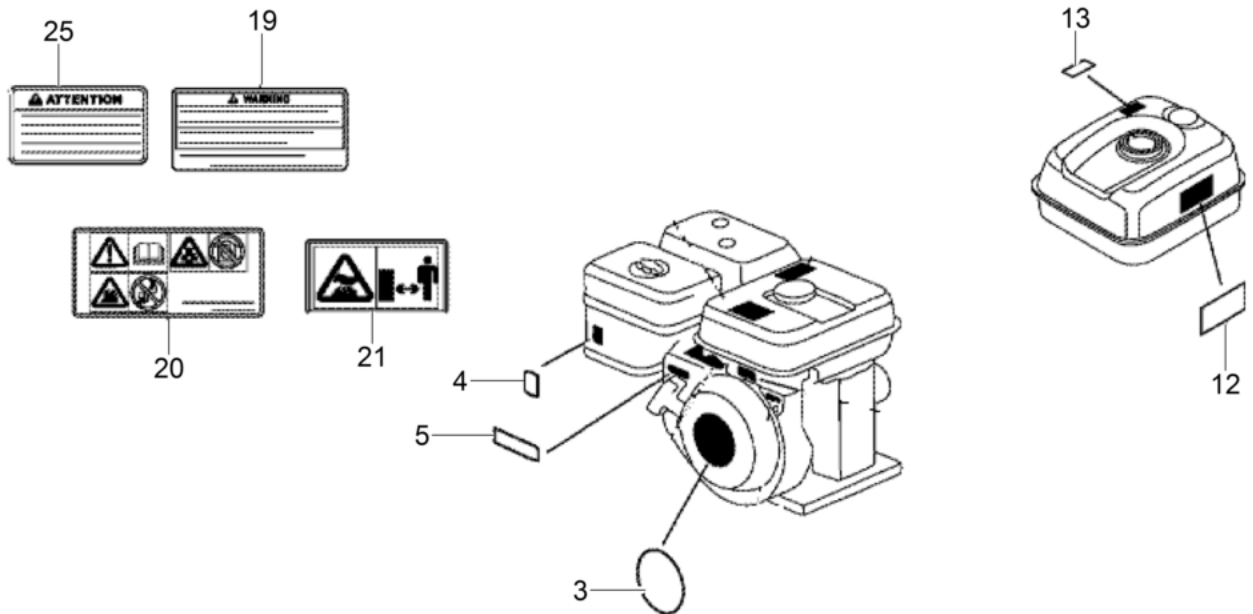

Pos. Ref.	Artikel Nr. Part No.	Qty.	Unit	Beschreibung Descripcion	Description Description	Abm. Measur.	Norm Standard
						Drehm. Torque	Schmierstoff Sealant
3	5100005352	1	PC	Aufkleber GX160 Calcomanía gx160	Label gx160 Autocollant gx160		
4	5100005336	1	PC	Aufkleber Calcomanía	Label Autocollant		
5	5000208623	1	PC	Aufkleber Calcomanias	Labels Autocollants		
12	5100000437	1	PC	Warnhinweiß Etiqueta amonestadora	Warning label Étiquette d'avertissement		
13	5100005337	1	PC	Aufkleber Calcomanía	Label Autocollant		
19	5100000438	1	PC	Warnhinweiß Etiqueta amonestadora	Warning label Étiquette d'avertissement		
20	5100000439	1	PC	Warnhinweiß Etiqueta amonestadora	Warning label Étiquette d'avertissement		
22	5100005340	1	PC	Aufkleber Calcomanía	Label Autocollant		
25	5100005339	1	PC	Aufkleber Calcomanía	Label Autocollant		

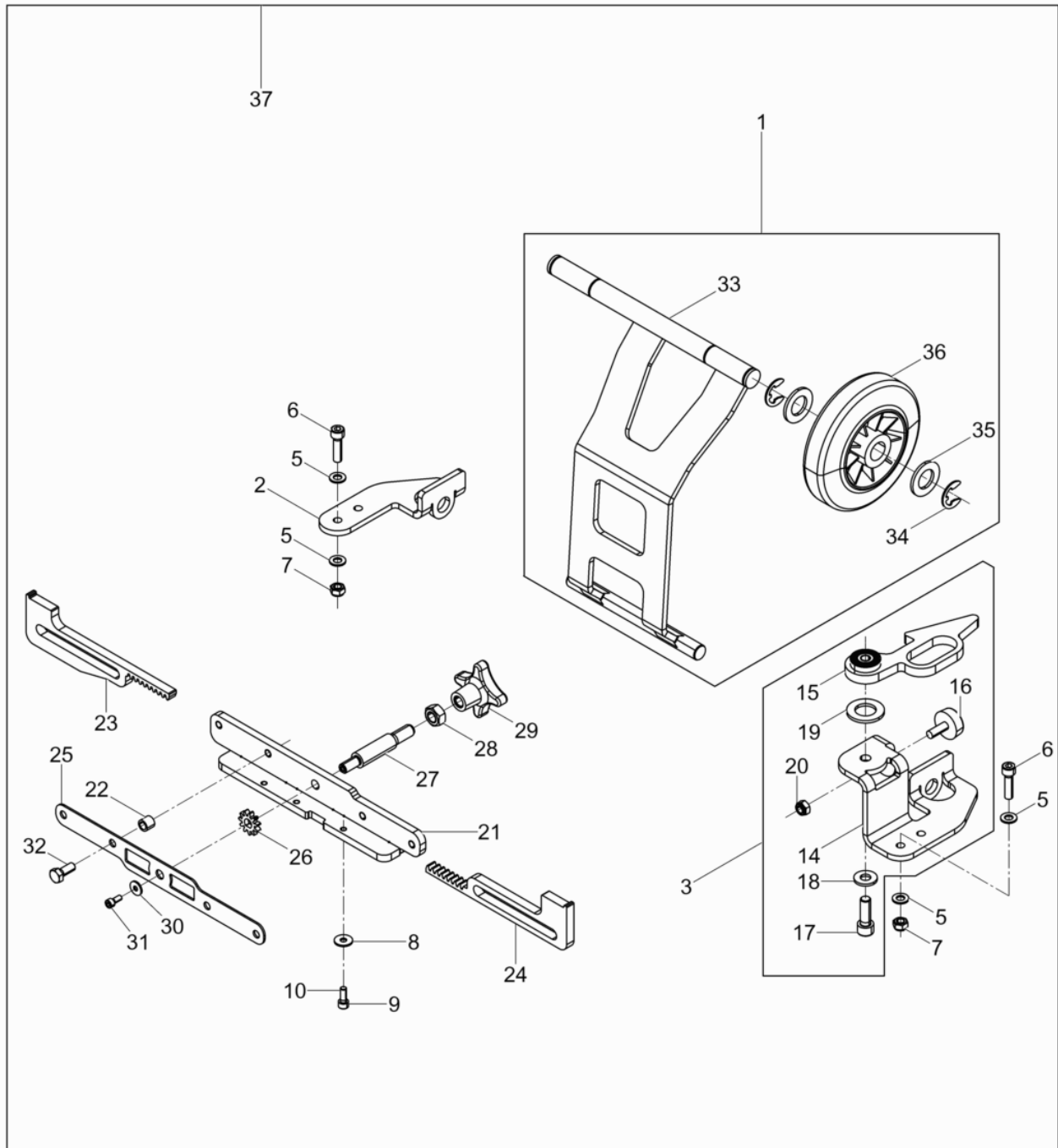

Pos. Ref.	Artikel Nr. Part No.	Qty.	Unit	Beschreibung Description	Description Description	Abm. Measur.	Norm Standard
						Drehm. Torque	Schmierstoff Sealant
1	5100037781	1	PC	Räder Kpl. Ruedas cpl.	Wheels cpl. Roues cpl.		
2	5100018399	1	PC	Winkel Links Ángulo izquierdo	Angle left Coude gauche		
3	5100037782	1	PC	Winkel Rechts Kpl. Ángulo derecho cpl.	Angle right cpl. Coude droite cpl.		
5	5000010622	8	PC	Scheibe Arandela	Flat washer Rondelle		
6	5000011541	4	PC	Zylinderschraube Tornillo cilíndrico	Cheese head screw Vis à tête cylindrique		
7	5000033356	4	PC	Sechskantmutter Tuerca hexagonal	Hexagon nut Écrou hexagonal		
8	5000010373	3	PC	Scheibe Arandela	Flat washer Rondelle	6	ISO7093
9	5000011553	3	PC	Zylinderschraube Tornillo cilíndrico	Cheese head screw Vis à tête cylindrique	49Nm/36ft.lbs	
10	5000011548	3	PC	Zylinderschraube Tornillo cilíndrico	Cheese head screw Vis à tête cylindrique		
14	5100018400	1	PC	Winkel Rechts Ángulo derecho	Angle right Coude droite		
15	5100027076	1	PC	Haken Kpl. Gancho cpl.	Hook cpl. Crochet cpl.		
16	5100016317	1	PC	Anschlagpuffer Amortiguador	Shockmount Silentbloc	30 x 15 25Nm/18ft.lbs	
17	5000011534	1	PC	Zylinderschraube Tornillo cilíndrico	Cheese head screw Vis à tête cylindrique	M10 x 30 49Nm/36ft.lbs	ISO4762
18	5000033988	1	PC	Spannscheibe Arandela elástica	Lockwasher Rondelle de ressort	10	DIN6796
19	5000010616	1	PC	Scheibe Arandela	Flat washer Rondelle		
20	5000033356	1	PC	Sechskantmutter Tuerca hexagonal	Hexagon nut Écrou hexagonal		
21	5100037765	1	PC	Winkel Ángulo	Angle Coude		
22	5100037766	4	PC	Buchse Buje	Bush Boîte		
23	5100037772	1	PC	Zahnstange Cremallera	Gear rod Crémaillère		
24	5100037770	1	PC	Zahnstange Cremallera	Gear rod Crémaillère		
25	5100037767	1	PC	Blech Chapa	Plate Tôle		
26	5100037769	1	PC	Zahnrad Engranaje	Gear Engrenage		
27	5100037768	1	PC	Achse Eje	Axle Axe		
28	5000010884	1	PC	Sechskantmutter Tuerca hexagonal	Hexagon nut Écrou hexagonal	M12	DIN934
29	5000097454	1	PC	Kreuzgriff Empuñadura	Star-handle Poignée étoile		
30	5000010372	1	PC	Scheibe Arandela	Flat washer Rondelle	B5,3	DIN9021
31	5000043307	1	PC	Zylinderschraube Tornillo cilíndrico	Cheese head screw Vis à tête cylindrique	M5 x 12	ISO4762
32	5000012362	4	PC	Sechskantschraube Tornillo hexagonal	Hexagonal head cap screw Vis à tête hexagonale		

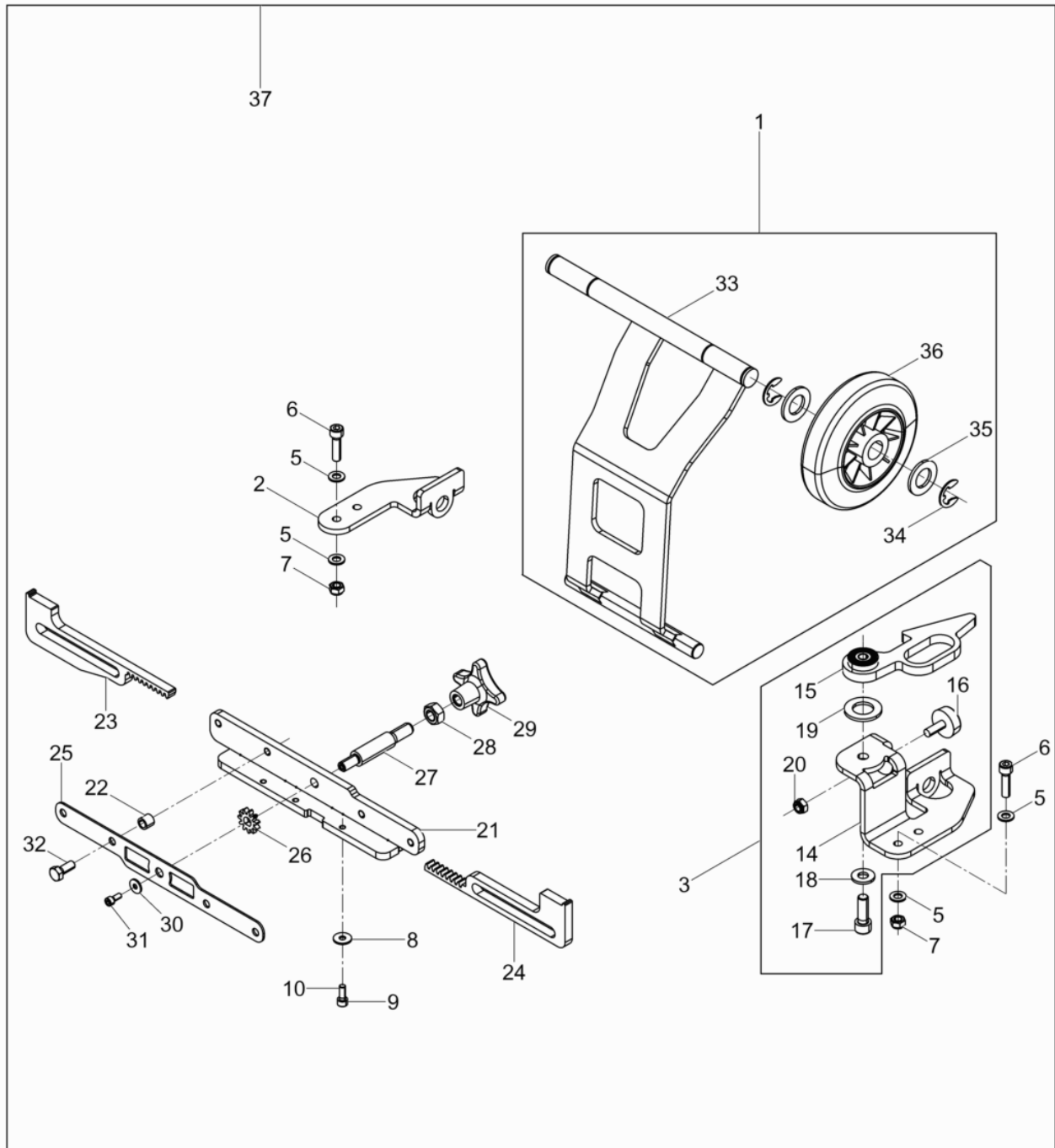

Pos. Ref.	Artikel Nr. Part No.	Qty.	Unit	Beschreibung Descripcion	Description Description	Abm. Measur.	Norm Standard
						Drehm. Torque	Schmierstoff Sealant
33	5100018385	1	PC	Fahrgestell Dispositivo de transporte	Trolley Chassis		
34	5000103834	4	PC	Sicherungsscheibe Arandela de seguridad	Lock washer Rondelle d'arrêt	15	DIN6799
35	5000010616	4	PC	Scheibe Arandela	Flat washer Rondelle		
36	5000021466	2	PC	Rad Rueda	Tire Roue	140 x 37,5	
37	5100028844	1	PC	Radsatz Kpl. Juego de rueda cpl.	Wheel kit cpl. Jeu de roue cpl.		

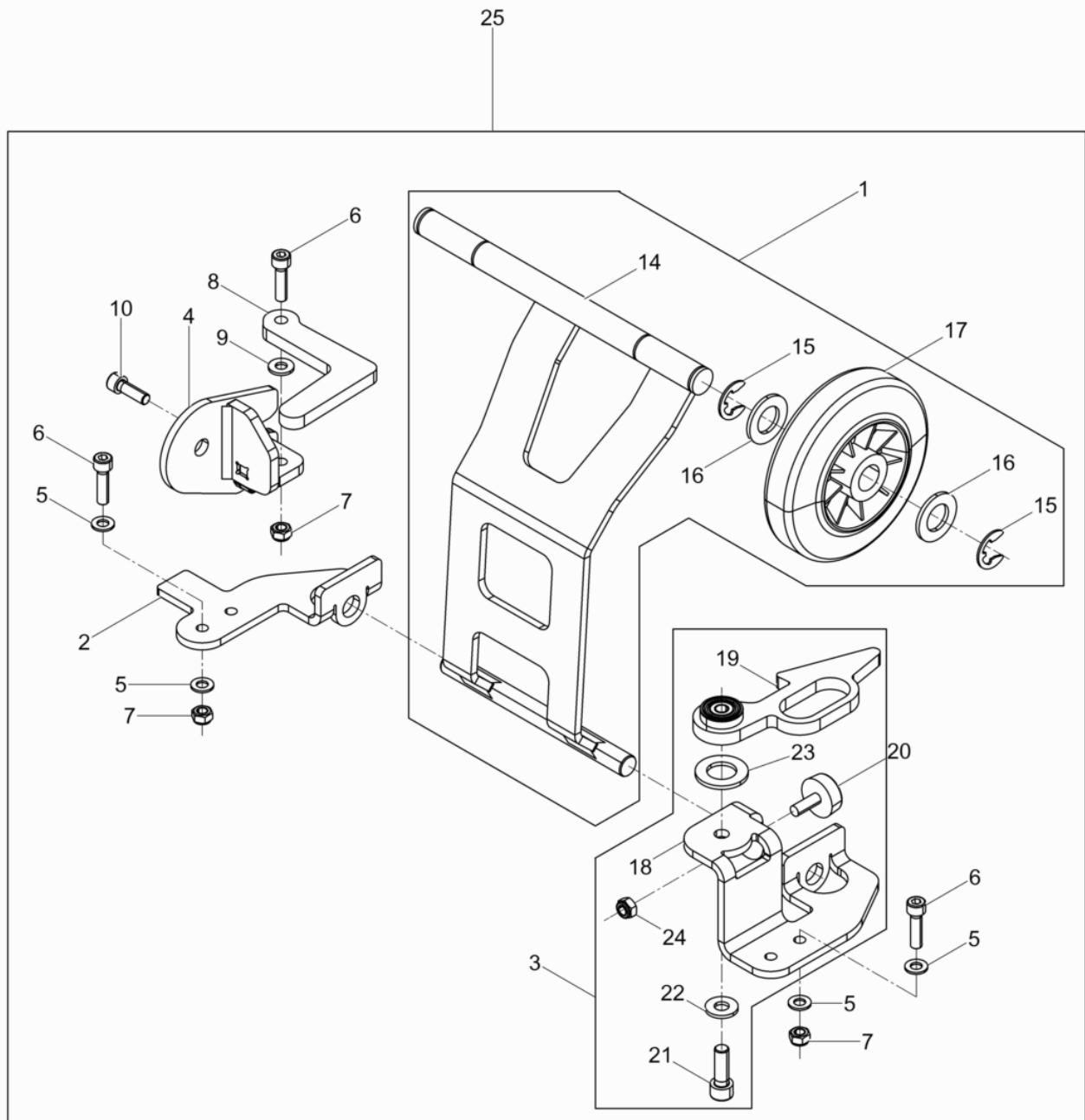

Pos. Ref.	Artikel Nr. Part No.	Qty.	Unit	Beschreibung Descripcion	Description Description	Abm. Measur.	Norm Standard
						Drehm. Torque	Schmierstoff Sealant
1	5100037781	1	PC	Räder Kpl. Ruedas cpl.	Wheels cpl. Roues cpl.		
2	5100045323	1	PC	Winkel Geschw. Ángulo	Angle Coude		
3	5100037782	1	PC	Winkel Rechts Kpl. Ángulo derecho cpl.	Angle right cpl. Coude droite cpl.		
5	5000010622	8	PC	Scheibe Arandela	Flat washer Rondelle		
6	5000011456	5	PC	Sechskantschraube Tornillo hexagonal	Hexagonal head cap screw Vis à tête hexagonale		
7	5000033356	5	PC	Sechskantmutter Tuerca hexagonal	Hexagon nut Écrou hexagonal		
8	5100041307	1	PC	Hebel Palanca	Lever Levier		
9	5000033198	1	PC	Spannscheibe Arandela elástica	Lockwasher Rondelle de ressort	8 49Nm/36ft.lbs	DIN6796
10	5100027062	2	PC	Flachkopfschraube Tornillo de cabeza plana	Pan head screw Vis lentiforme	M8x20	
14	5100018385	1	PC	Fahrgestell Dispositivo de transporte	Trolley Chassis		
15	5000103834	4	PC	Sicherungsscheibe Arandela de seguridad	Lock washer Rondelle d'arrêt	15	DIN6799
16	5000010616	4	PC	Scheibe Arandela	Flat washer Rondelle		
17	5000021466	2	PC	Rad Rueda	Tire Roue	140 x 37,5	
18	5100018400	1	PC	Winkel Rechts Ángulo derecho	Angle right Coude droite		
19	5100027076	1	PC	Haken Kpl. Gancho cpl.	Hook cpl. Crochet cpl.		
20	5100016317	1	PC	Anschlagpuffer Amortiguador	Shockmount Silentbloc	30 x 15	
21	5000011534	1	PC	Zylinderschraube Tornillo cilíndrico	Cheese head screw Vis à tête cylindrique	M10 x 30 49Nm/36ft.lbs	ISO4762
22	5000033988	1	PC	Spannscheibe Arandela elástica	Lockwasher Rondelle de ressort	10	DIN6796
23	5000010616	1	PC	Scheibe Arandela	Flat washer Rondelle		
24	5000033356	1	PC	Sechskantmutter Tuerca hexagonal	Hexagon nut Écrou hexagonal		
25	5100041384	1	PC	Fahrgestell Kpl. Dispositivo de transporte cpl.	Trolley cpl. Chassis cpl.		

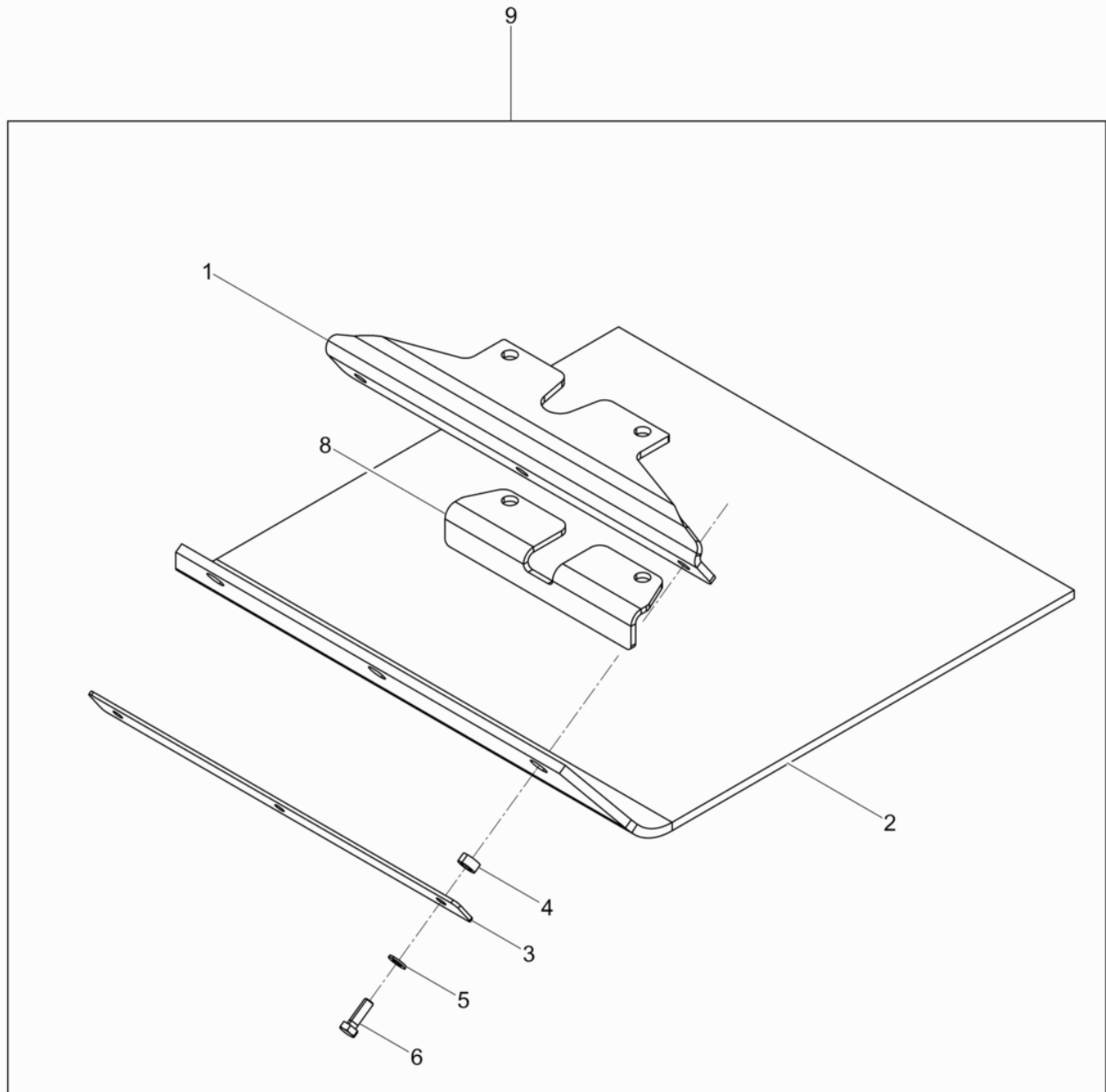

Pos. Ref.	Artikel Nr. Part No.	Qty.	Unit	Beschreibung Descripción	Description Description	Abm. Measur.	Norm Standard
						Drehm. Torque	Schmierstoff Sealant
1	5100029997	1	PC	Winkel Kpl. Ángulo cpl.	Angle cpl. Coude cpl.		
2	5100016466	1	PC	Kunststoffplatte Juego de lamina de uretano	Urethane plate Dispositif de glissement		
3	5100016467	1	PC	Blech Chapa	Plate Tôle		
4	5100017122	3	PC	Buchse Buje	Bush Boîte		
5	5000010622	3	PC	Scheibe Arandela	Flat washer Rondelle		
6	5000011457	3	PC	Sechskantschraube Tornillo hexagonal	Hexagonal head cap screw Vis à tête hexagonale	M8 x 25 31Nm/23ft.lbs	
8	5100037796	1	PC	Blech Chapa	Plate Tôle		
9	5100029996	1	PC	Gleitvorrichtung Placa de deslizamiento	Urethane pad kit Jeu de tapis en polyuréthane		

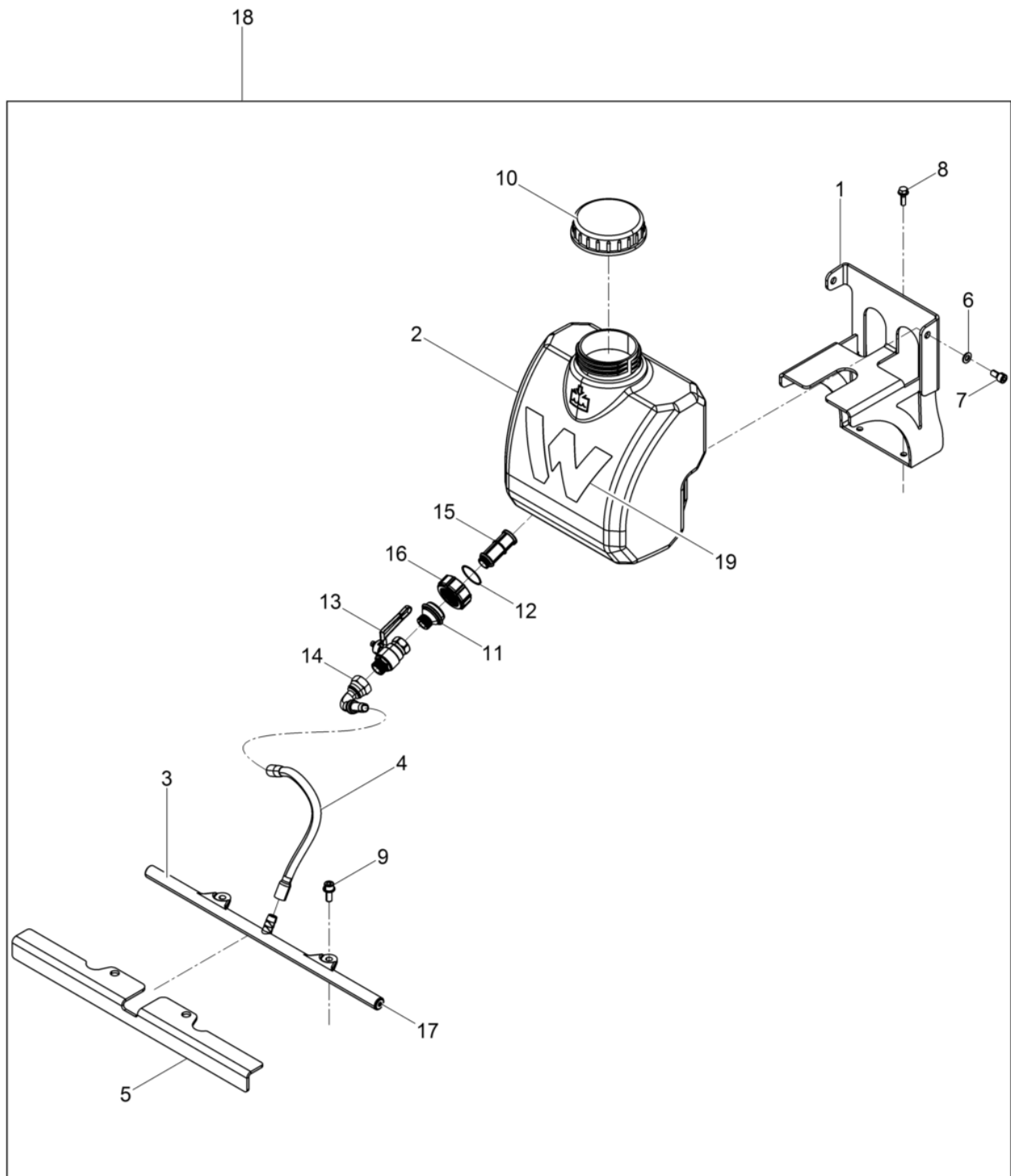

Pos. Ref.	Artikel Nr. Part No.	Qty.	Unit	Beschreibung Descripcion	Description Description	Abm. Measur.	Norm Standard
						Drehm. Torque	Schmierstoff Sealant
1	5100028912	1	PC	Wassertankhalterung Soporte	Fixing device Bague de retenue		
2	5100028898	1	PC	Wassertank Tanque de agua	Watertank Reservoir à eau		
3	5100029616	1	PC	Berieselung Kpl. Systema de riego cpl.	Spinkler system cpl. Installation d'arrosage cpl.		
4	5100028892	1	PC	Wasserschlauch Manguera de agua	Water hose Tuyau d'eau		
5	5100030990	1	PC	Schutzblech Chapa protectora	Guard plate Tôle de protection		
6	5000010622	2	PC	Scheibe Arandela	Flat washer Rondelle		
7	5000011544	2	PC	Zylinderschraube Tornillo cilíndrico	Cheese head screw Vis à tête cylindrique	M8 x 16 25Nm/18ft.lbs	ISO4762
8	5100035900	4	PC	Sechskantschraube Tornillo hexagonal	Hexagonal head cap screw Vis à tête hexagonale		
9	5100042618	2	PC	Zylinderschraube Tornillo cilíndrico	Cheese head screw Vis à tête cylindrique		
10	5000068351	1	PC	Schraubdeckel Tapa roscable	Screwed cover Couvercle fileté		
11	5100028921	1	PC	Flansch Brida	Flange Bride		
12	5100028922	1	PC	O-Ring Anillo-o	O-ring Bague-o		
13	5100028889	1	PC	Kugelhahn Llave esférica	Ball valve Robinet à boisseau sqherique		
14	5100028897	1	PC	Pressnippel Conector	Connector Connexion		
15	5100028890	1	PC	Wasserfilter Filtro de agua	Water filter Filtre		
16	5100028920	1	PC	Überwurfmutter Tuerca de racor	Cap screw Écrou d'accouplement		
17	5100029615	2	PC	Einschraubstopfen Tapón	Plug Bouchon		
18	5100029067	1	PC	Berieselung Sistema de rociado	Water system Système diffuseur		
19	1000360098	1	PC	Aufkleber Calcomania	Label Autocollant		

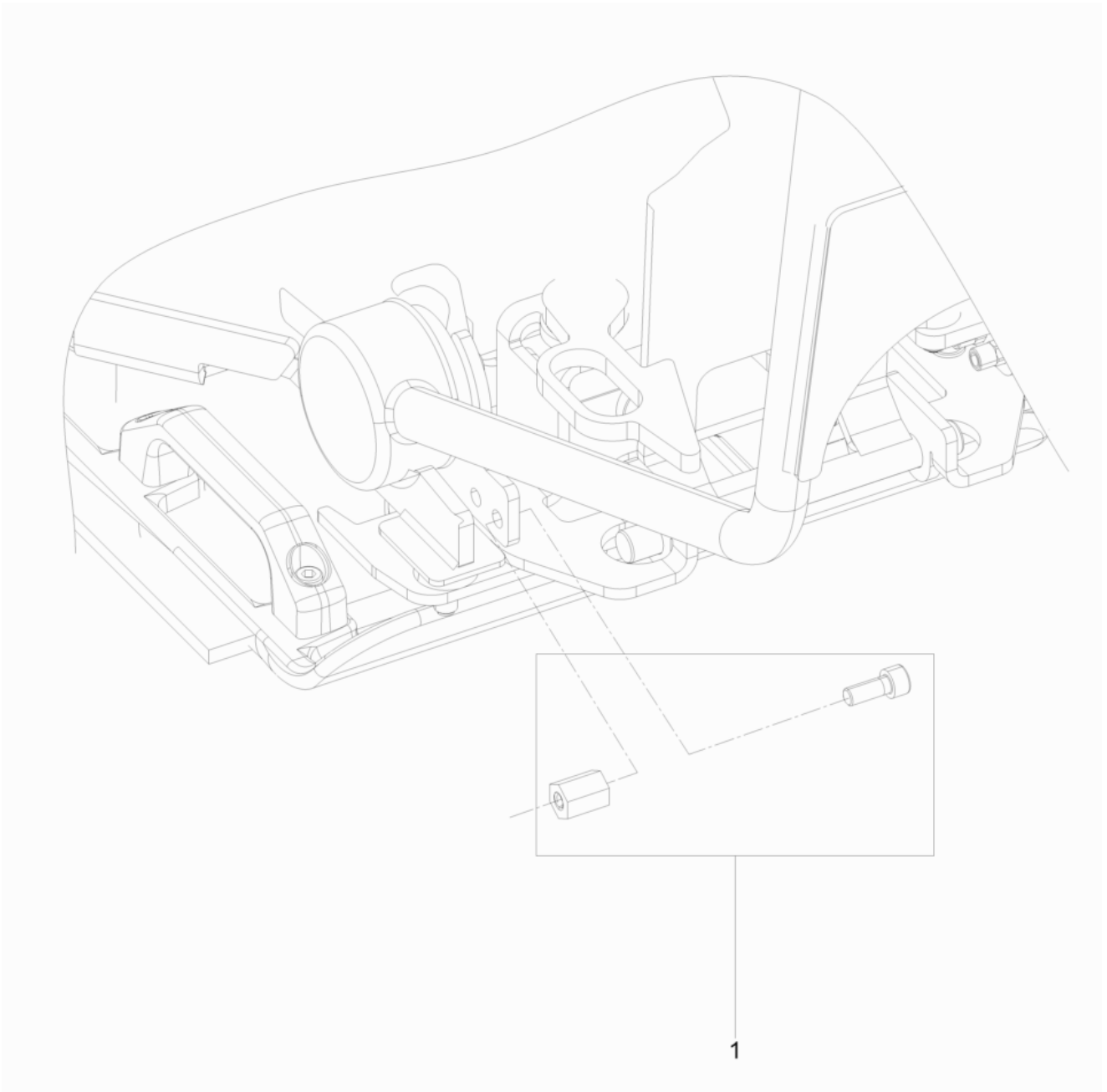

VP1550Aw**Arretierung Bügel
Lock shackle
Dispositivo de retenciónestribo
Dispositif d'arrêt étrier**

Pos. Ref.	Artikel Nr. Part No.	Qty.	Unit	Beschreibung Descripción	Description Description	Abm. Measurem.	Norm Standard
						Drehm. Torque	Schmierstoff Sealant
1	5100044649	1	PC	Arretierung Bügel Dispositivo de retenciónestribo	Lock shackle Dispositif d'arrêt étrier		





**WACKER
NEUSON**