



**WACKER
NEUSON**

5100026869	101
09.2018	

**Reversible Plates
Reversierbare Platten
Planchas Reversibles
Plaques réversible**

DPU110Lec870

**Parts Book
Ersatzteile
Lista de Repuestos
Liste de Pièces de Rechange**

www.wackerneuson.com

A nameplate listing the Model Number, Item Number, Revision, and Serial Number is attached to each unit. Please record the information found on this plate so it will be available should the nameplate become lost or damaged. When ordering parts or requesting service information, you will always be asked to specify the model, item number, revision number, and serial number of the unit.

Ein Typenschild mit Typ, Artikelnummer, Version und Maschinen-Nummer ist an jedem Gerät angebracht. Die Daten von diesem Schild bitte notieren, damit sie auch bei Verlust oder Beschädigung des Schildes noch vorhanden sind. Der Typ, die Artikel-Nummer, die Versions- Nummer und die Maschinen-Nummer sind bei der Ersatzteilbestellung oder Nachfragen bezüglich Service-Informationen stets erforderlich.

Una placa de identificación con el modelo, número de referencia, nivel de revisión y número de serie ha sido añadida en cada máquina. Favor de anotar los datos en la placa en caso de que la placa de identificación sea destruida o perdida. En todos los pedidos para repuestos necesita siempre el modelo, el número de referencia, el nivel de revisión y el número de serie de la máquina en cuestión.

Une plaque signalétique mentionnant le modèle, le numéro de référence, le niveau de révision et le numéro de série est fixée sur chaque machine. Veuillez noter les informations relevées sur cette plaque de façon à ce qu'elles soient toujours disponibles si la plaque signalétique venait à être perdue ou endommagée. Lorsque vous commandez des pièces détachées ou vous sollicitez des informations après-vente, on vous demandera toujours de préciser le modèle, le numéro de référence, le niveau de révision et le numéro de série de la machine.

***My machine's numbers are / Die Nummern meines Gerätes sind /
Los números de mi máquina son / Les numéros de ma machine son :***



Part Numbers appearing in boldface type are recommended spare parts. This means that these parts are subject to wear under normal operating conditions and may require periodic service or replacement. It is recommended that these items be stocked to meet the expected service requirements of this model. Actual stocking quantities of these and other parts used in more extensive repairs will depend on the service practices of each customer.

Bei den in den Ersatzteillisten fettgedruckten Nummern handelt es sich um empfohlene Ersatzteile. Dies bedeutet, daß diese Teile bei normalen Anwendungsbedingungen natürlicher Abnutzung ausgesetzt sind und gelegentlich ersetzt oder überarbeitet werden müssen. Es wird geraten, diese Teile auf Lager bereit zu haben, um für Service-Arbeiten an diesem Gerät vorbereitet zu sein. Lagerbestände für diese und andere Teile, welche für ausgiebigere Reparaturarbeiten benötigt werden, können je nach Service-Gewohnheiten der einzelnen Kunden variieren.

Los números de partes en negritas en las Listas Ilustradas de Partes son los repuestos recomendados, ésto quiere decir que estas partes se desgastarán bajo circunstancias de funcionamiento normales y pueden requerir servicio periódico o su reemplazo. Se recomienda que el cliente mantenga un abastecimiento adecuado de estas partes para poder satisfacer la demanda requerida por el servicio a la máquina. La cantidad de repuestos que el cliente necesitará para reparaciones dependerá de la póliza de servicio de cada cliente.

Les numéros de pièces imprimés en caractères gras dans les Listes des Pièces Détachées de ce manuel sont les pièces détachées recommandées par la Wacker. Cela veut dire que ces pièces sont sujettes à usure dans des conditions de travail normales et peuvent nécessiter de l'entretien ou leur remplacement. Nous recommandons que vous disposez d'un stock de ces pièces pour pouvoir satisfaire la demande d'entretien de cette machine. Le client doit décider lui-même de la quantité exacte de pièces de rechange qu'il disposera dans ses stocks.

Baseplate cpl. DPU110 Untermasse kpl. DPU110 Masa inferior cpl. DPU110 Masse inferieure cpl. DPU110	10
Exciter cpl. DPU110 Erreger kpl. DPU110 Excitador cpl. DPU110 Excitateur cpl. DPU110	12
Upper Mass cpl. DPU110 Obermasse kpl. DPU110 Masa Superior cpl. DPU110 Massa Superieure cpl. DPU110	16
cabling cpl. DPU110 Verkabelung kpl. DPU110 cableado cpl. DPU110 câblage cpl. DPU110	18
Tank - Radiator DPU110 Tank - Kühler DPU110 Tanque - Radiador DPU110 Réservoir - Radiateur DPU110	20
Return filter Rücklauffilter Filtro de retorno Filtre de retour	24
Fuel Tank cpl. DPU110 Kraftstofftank kpl. DPU110 Tanque de Combustible cpl.DPU110 Réservoir de Carburant cpl.	26
Block-Hydraulic cpl. DPU80/110 Hydraulikblock kpl. DPU80/90/110 Bloque Hidráulico cpl.DPU80/110 Bloc Hydraulique cpl.	28
Diesel Engine cpl. DPU110 Dieselmotor kpl. DPU110 Motor Diesel cpl. DPU110 Moteur Diesel cpl. DPU110	30
Holder cpl. Halter kpl. Soporte cpl. Attache cpl.	34
Elektrobox kpl. DPU80/90/110 Elektrobox kpl. DPU80/90/110 Caja eléctrica cpl. DPU80/90/110 Coffret électrique cpl.	36
Air filter cpl. Luftfilter kpl. Filtro de aire cpl. Filtre à air cpl.	38
Locking device rear cpl. Verriegelung hinten kpl. Dispositivo de bloqueo atrás cpl. Dispositif de verrouillage	40
Battery cpl. Batterie kpl. Batería cpl. Batterie cpl.	42

Indice

Table des matières

Protective frame cpl. DPU110 Schutzrahmen kpl. DPU110 Armazón de protección cpl. DPU110 Cadre protection cpl. DPU110	44
Bonnet front cpl. DPU110 Haube vorne kpl. DPU110 Cubierta delantero cpl. DPU110 Capot avant cpl. DPU110	48
Bonnet rear cpl. DPU110 Haube hinten kpl. DPU110 Cubierta atrás cpl. DPU110 Capot arrière cpl. DPU110	50
center pole cpl. DPU110 Deichsel kpl. DPU110 Barra de mando cpl. DPU110 Timon cpl. DPU110	52
Support cpl. Deichselbock kpl. Caballete de apoyo cpl. Support cpl.	54
center pole base cpl. Deichselunterteil kpl. Barra de mando parte inferior cpl. Timon partie inferieure cpl.	56
Center Pole Head cpl. DPU110 Deichselkopf kpl. DPU110 Cabezal de Barra cpl. DPU110 Tête de Timon cpl. DPU110	58
Bonnet cpl. Haube kpl. Cubierta cpl. Capot cpl.	60
Compatec cpl. Compatec kpl. Compatec cpl. Compatec cpl.	62
Labels Aufkleber Calcomanías Autocollants	64
Engine DPU110 Motor DPU110 Motor DPU110 Moteur DPU110	67
Crankshaft Kurbelwelle Cigüeñal Vilebrequin	68
Piston - Connecting Rod Kolben - Pleuel Pistón - Biela Piston - Bielle	70
Fly wheel Schwungrad Volante Volant	72

V-belt pulley Riemenscheibe Polea Poulie	74
Crankcase Kurbelgehäuse Cárter Carter	76
Cylinder head Zylinderkopf Culata Culasse	80
Cylinder head cover Zylinderkopfdeckel Tapa del cilindro Couvercle supérieur	82
Injection System Einspritzanlage Sistema de Inyección Équipement d' Injection	84
Camshaft Nockenwelle Arbol de levas Arbre à cames	88
Rocker Arms - Valves Kipphebel - Ventile Balancines - Válvulas Culbuteurs - Soupapes	90
timing belt Steuerriemen Polea tensora de correa Tendeur de courroie	92
Oil pump Ölpumpe Bomba de aceite Pompe à huile	94
Oil pan Ölwanne Carter de Aceite Cuvette Carter à Huile	96
Speed control module Drehzahlregler Controlador de velocidad Régulateur de vitesse	98
Steering Steuerung Dirección Direction	100
Fuel Pump Kraftstoffpumpe Bomba de combustible Pompe à essence	102
Fuel Pipes Kraftstoffleitungen Tubos de Combustible Conduites de Carburant	104

Indice

Table des matières

Thermostat Thermostat Termóstato Thermostat	106
Water Pump Wasserpumpe Bomba de agua Pompe d'eau	108
Inlet bend Ansaugkrümmer Codo de aspiración Coude d'aspiration	110
Exhaust manifold Auspuffkrümmer Múltiple de escape Coude d'échappement	112
Generator Generator Generador Générateur	114
Starter Anlasser Starter Démarreur	116
Glow plug Glühkerzen Tapón luminoso Bougie de préchauffage	118
Covering Abdeckung Cubierta Couverture	120

Baseplate cpl. DPU110
Untermasse kpl. DPU110
Masa inferior cpl. DPU110
Masse inferieure cpl. DPU110

DPU110Lec870

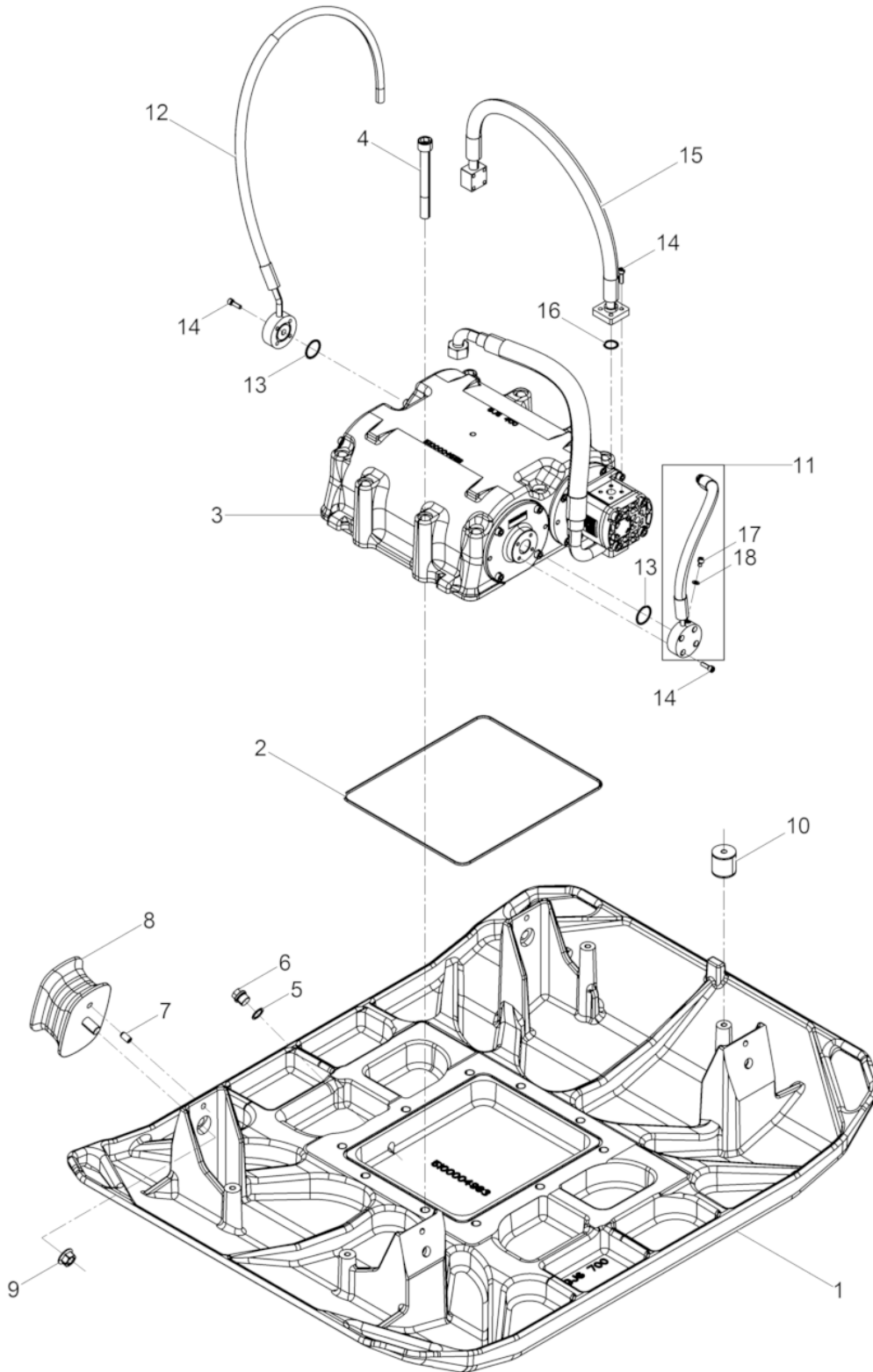

Ref. Pos.	Part No. Artikel Nr.	Qty. St.	Description Beschreibung	Descripción Description	Measur./Abm.	Norm
					Torque/Drehm.	Sealant Schmierstoff
1	5100004984	1	Baseplate 870 Untermasse 870	Masa inferior 870 Masse inferieure 870		
1	5100004986	1	Baseplate 970 Untermasse 970	Masa inferior 970 Masse inferieure 970		
2	5100010363	1	O-Ring O-Ring	Anillo-O Bague-O		
3	5100013824	1	Exciter cpl. (DPU110) Erreger kpl. (DPU110)	Excitador cpl. (DPU110) Excitateur cpl. (DPU110)		
4	5100009777	10	Cheese head screw Zylinderschraube	Tornillo cilíndrico Vis à tête cylindrique		
5	0019156	1	Gasket Dichtring	Anillo de junta Bague d'étanchéité		
6	0068222	1	Plug (threaded) Verschlußschraube	Tapón roscado Bouchon		
7	0203227	4	Roll pin Spannstift	Pasador Goupille de tension		
8	0216648	4	Silent block Gummipuffer	Bloque silente Silentbloc		
9	0212628	4	Locknut Sicherungsmutter	Contratuerca Contre-écrou		
10	0216644	4	Shockmount Puffer	Amortiguador Silentbloc		
11	5100010051	1	Hose pipe Schlauchleitung	Conducto flexible Conduite flexible		
12	5100010160	1	Breather tube Entlüftungsleitung	Línea de purgado Tuyau d'évacuation purge		
13	5100010115	2	O-Ring O-Ring	Anillo-O Bague-O		
14	0012373	12	Cheese head screw Zylinderschraube	Tornillo cilíndrico Vis à tête cylindrique	10Nm/7ft.lbs	
15	5100009781	1	Hose pipe Schlauchleitung	Conducto flexible Conduite flexible		
16	0210116	1	O-Ring O-Ring	Anillo-O Joint torique		
17	0014425	1	Cheese head screw Zylinderschraube	Tornillo cilíndrico Vis à tête cylindrique	10Nm/7ft.lbs	
18	5100022402	1	Gasket Dichtring	Anillo de junta Bague détanchéité		

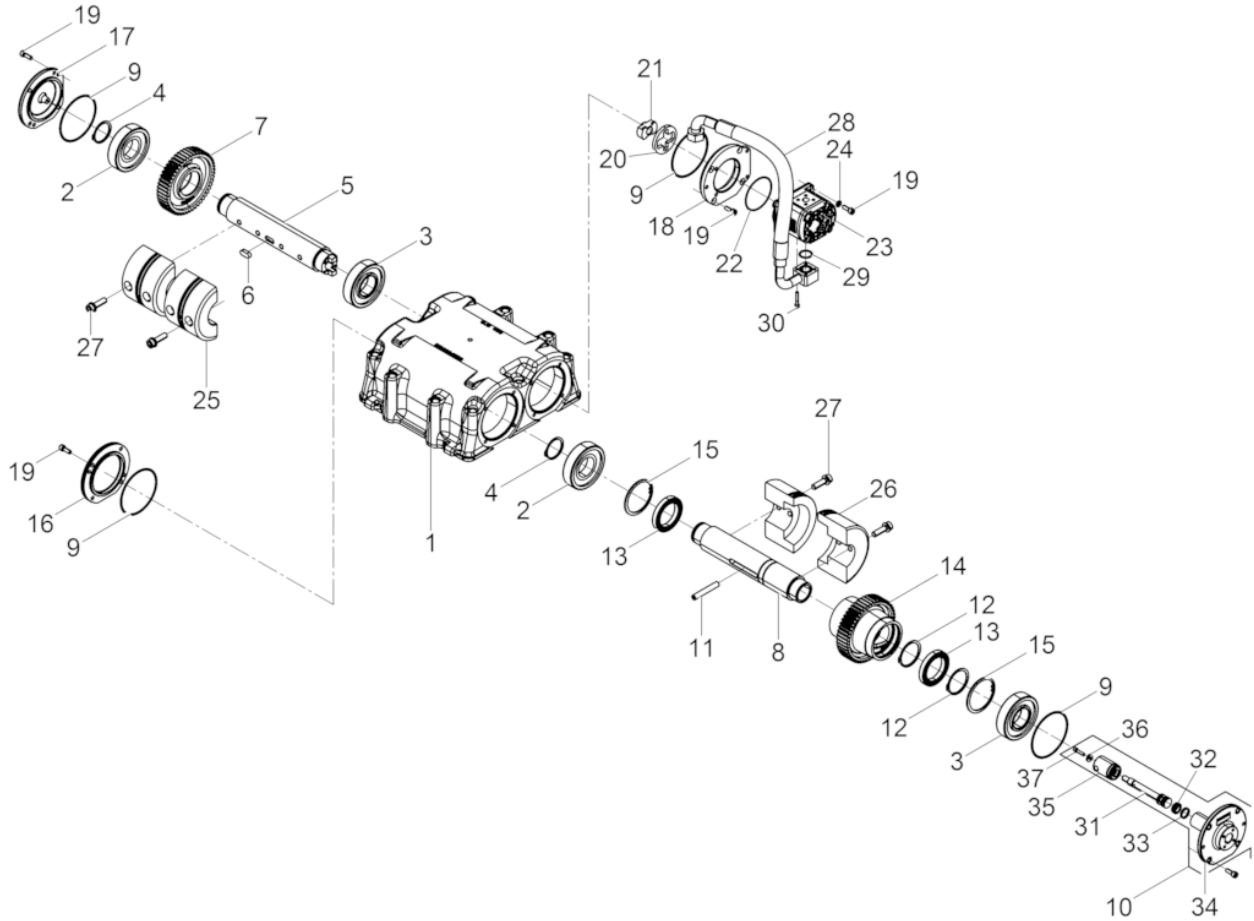

Ref. Pos.	Part No. Artikel Nr.	Qty. St.	Description Beschreibung	Descripción Description	Measurem./Abm.	Norm
					Torque/Drehm.	Sealant Schmierstoff
1	5100004557	1	Exciter housing Erregergehäuse	Carcasa del excitador Carter excitateur		
2	5100010479	2	Cylindrical roller bearing Zylinderrollenlager	Rodamiento cilíndricos Roulement à rouleaux cylindriq		
3	5100015097	2	Cylindrical roller bearing Zylinderrollenlager	Rodamiento cilíndricos Roulement à rouleaux cylindriq		
4	2006113	2	Retaining ring Sicherungsring	Anillo de retención Bague d'arrêt		
5	5100004298	1	Driving shaft Antriebswelle	Albero comando Arbre d'entraînement		
6	2006603	1	Fitting key Passfeder	Chaveta Clavette		
7	5100004306	1	Gear Zahnrad	Engranaje Engrenage		
8	5100004300	1	Shaft Verstellwelle	Árbol Arbre		
9	5100005660	4	O-Ring O-Ring	Anillo-O Bague-O		
10	5100004284	1	Adjustment cylinder cpl. Verstellzylinder kpl.	Cilindro del ajuste cpl. Cylindre d'ajustement cpl.		
11	5100005449	1	Tripping pin Schaltstift	Espiga de mando Broche de manoeuvre		
12	0043180	2	Retaining ring Sicherungsring	Anillo de retención Bague d'arrêt		
13	5100005505	2	Grooved ball bearing Rillenkugellager	Rodamiento de bolas Roulement rainuré à billes		
14	5100004303	1	Adjusting sleeve Verstellhülse	Husillo de regulación Douille de réglage		
15	5100005659	2	Retaining ring Sicherungsring	Anillo de retención Bague d'arrêt		
16	5100004295	1	Cover Deckel	Tapa Couvercle		
17	5100004294	1	Vent cover Belüftungsdeckel	Tapa de ventilación Couvercle d'aeration		
18	5100004409	1	Flange Flansch	Brida Bride		
19	0012629	20	Cheese head screw Zylinderschraube	Tornillo cilíndrico Vis à tête cylindrique	25Nm/18ft.lbs	
20	5100003535	1	Disc Kreuzscheibe	Disco Disque		
21	5100003696	1	Carrier Mitnehmer	Arrastrador Levier d'entraînement		
22	5100004118	1	O-ring O-Ring	Anillo-O Bague-O		
23	5100005739	1	Gear pump right Zahnradpumpe rechts	Bomba de engranajes derecha Pompe d'engrenages droite		
24	0010742	4	Washer Scheibe	Arandela Rondelle		
25	5100016126	2	Eccentric weight Unwucht	Masa excéntrica Balourd		

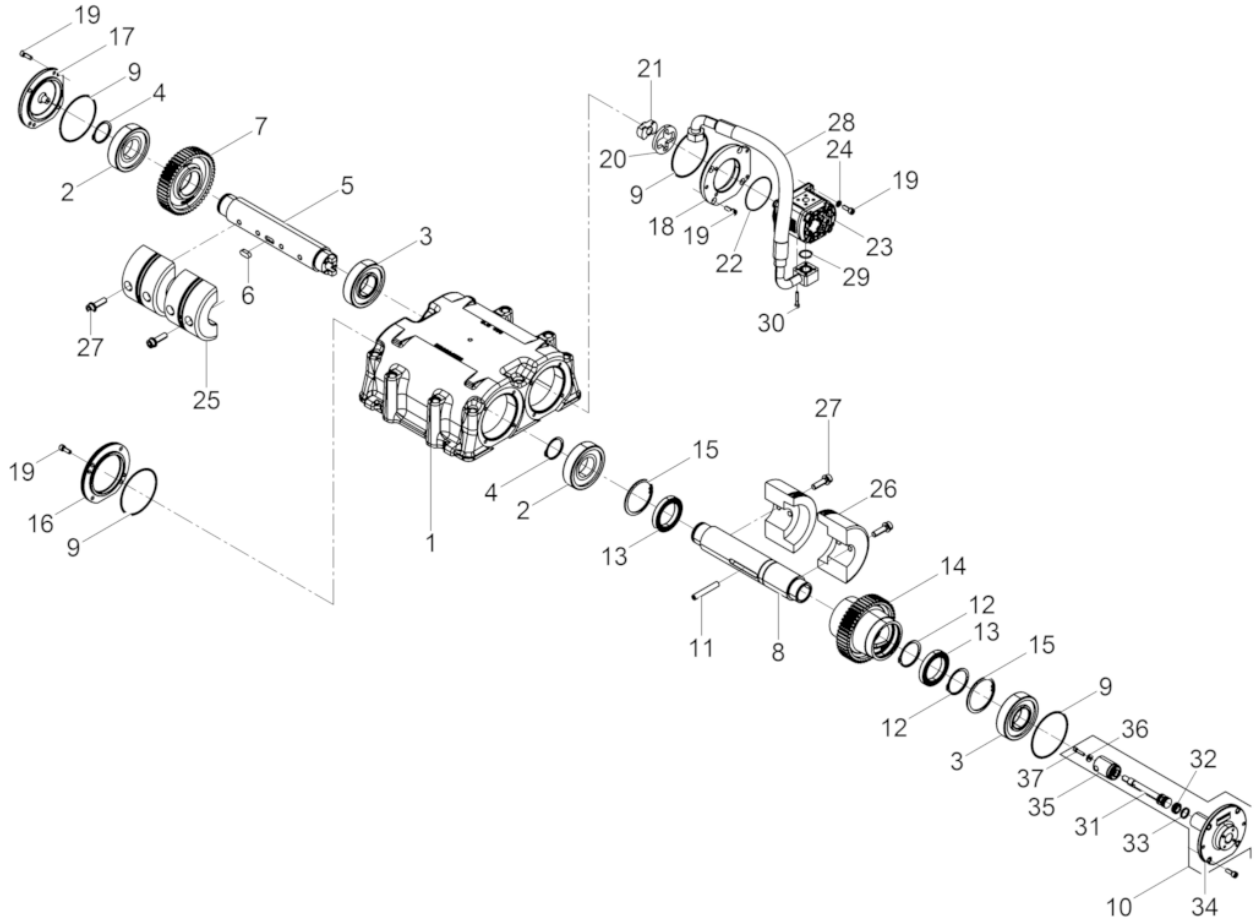

Ref. Pos.	Part No. Artikel Nr.	Qty. St.	Description Beschreibung	Descripción Description	Measurement./Abm.	Norm
					Torque/Drehm.	Sealant Schmierstoff
26	5100016127	2	Eccentric weight Unwucht	Masa excéntrica Balourd		
27	5100005604	8	corrugated-head screw Sicherungsschraube	Tornillo Vis		
28	5100009783	1	Hose pipe Schlauchleitung	Conducto flexible Conduite flexible		
29	0210115	1	O-Ring O-Ring	Anillo-O Joint torique		
30	0011549	4	Cheese head screw Zylinderschraube	Tornillo cilíndrico Vis à tête cylindrique	M6 x 30 10Nm/7ft.lbs	ISO4762
31	5100004283	1	Piston Kolben	Pistón Piston		
32	5100005657	1	Ring Nutting	Anillo Anneau		
33	5100005658	1	Ring Ring	Anillo Anneau		
34	5100004281	1	Cylinder Zylinder	Cilindro Cylindre		
35	5100016693	1	Piston cpl. Kolben kpl.	Pistón cpl. Piston cpl.		
36	0124717	1	Washer Scheibe	Arandela Rondelle		
37	0220001	1	Cheese head screw Zylinderschraube	Tornillo cilíndrico Vis à tête cylindrique		

Upper Mass cpl. DPU110
Obermasse kpl. DPU110
Masa Superior cpl. DPU110
Massa Superieure cpl. DPU110

DPU110Lec870

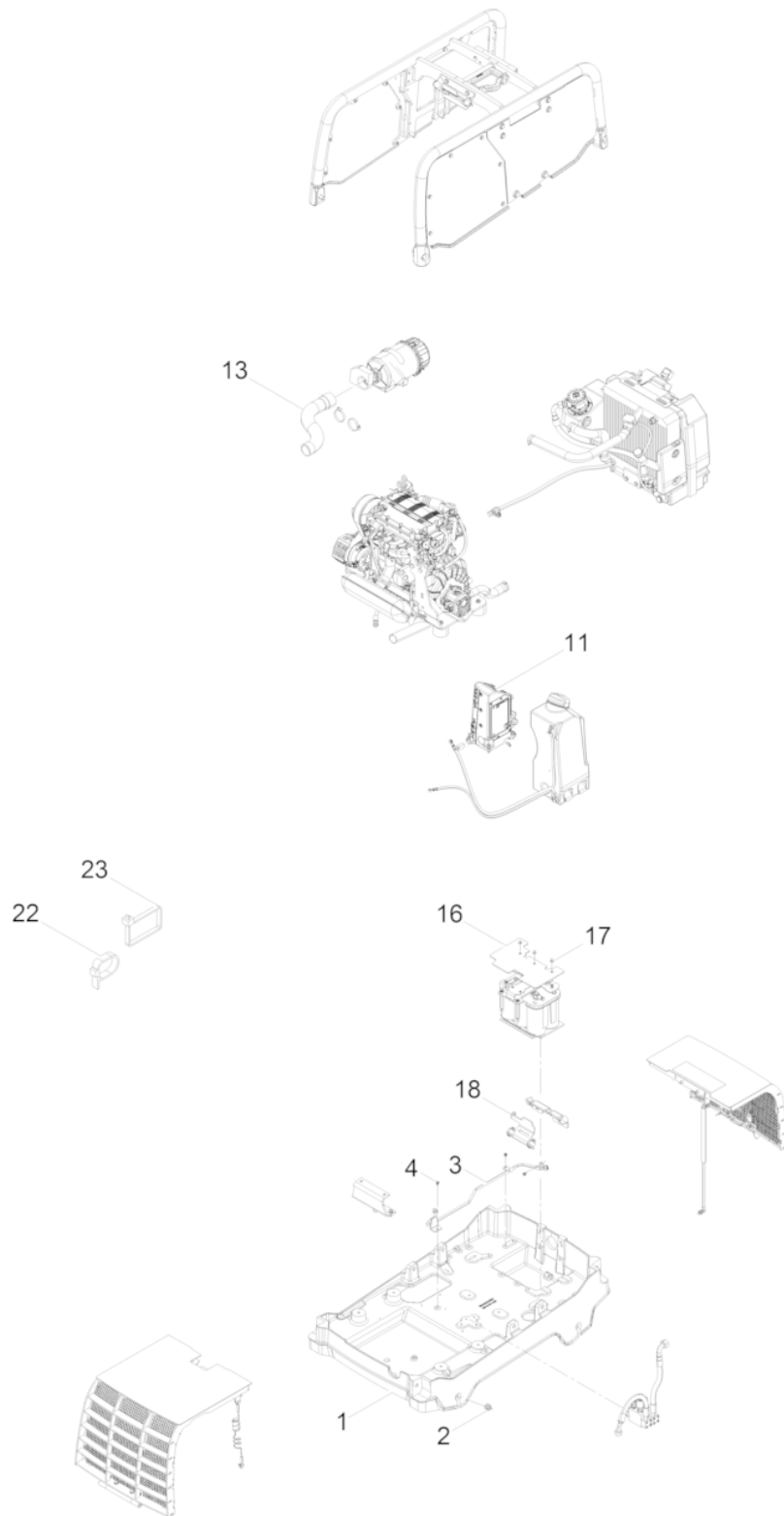

Ref. Pos.	Part No. Artikel Nr.	Qty. St.	Description Beschreibung	Descripción Description	Measurement./Abm.	Norm
					Torque/Drehm.	Sealant Schmierstoff
1	5100004995	1	Upper Mass Obermasse	Masa Superior Masse Superieure		
2	0212628	4	Locknut Sicherungsmutter	Contratuercas Contre-écrou	210Nm/155ft.lbs	
3	5100010049	1	Pipe Rohr	Tubo Tube		
4	5100010512	3	corrugated-head screw Sicherungsschraube	Tornillo Vis		
11	5100013830	1	Electric box cpl. Elektrobox kpl.	Caja eléctrica cpl. Coffret électrique cpl.		
13	5100006055	1	Suction hose Ansaugschlauch	Manguera de succión Tuyau de succion		
16	5100010883	1	Protective cloth Schutzlappen	Trapo de protección Protection		
17	5100027359	3	Disc Scheibe	Disco Disque		
18	5100018109	1	locking lever cpl. Verriegelungshebel kpl.	palanca de bloqueo cpl. levier de verrouillage cpl.		
22	0047388	20	Cable yarn Kabelbinder	Fijación de cables Attache de câble		
23	0038489	10	Tie cable Kabelbinder	Fijación Attache		

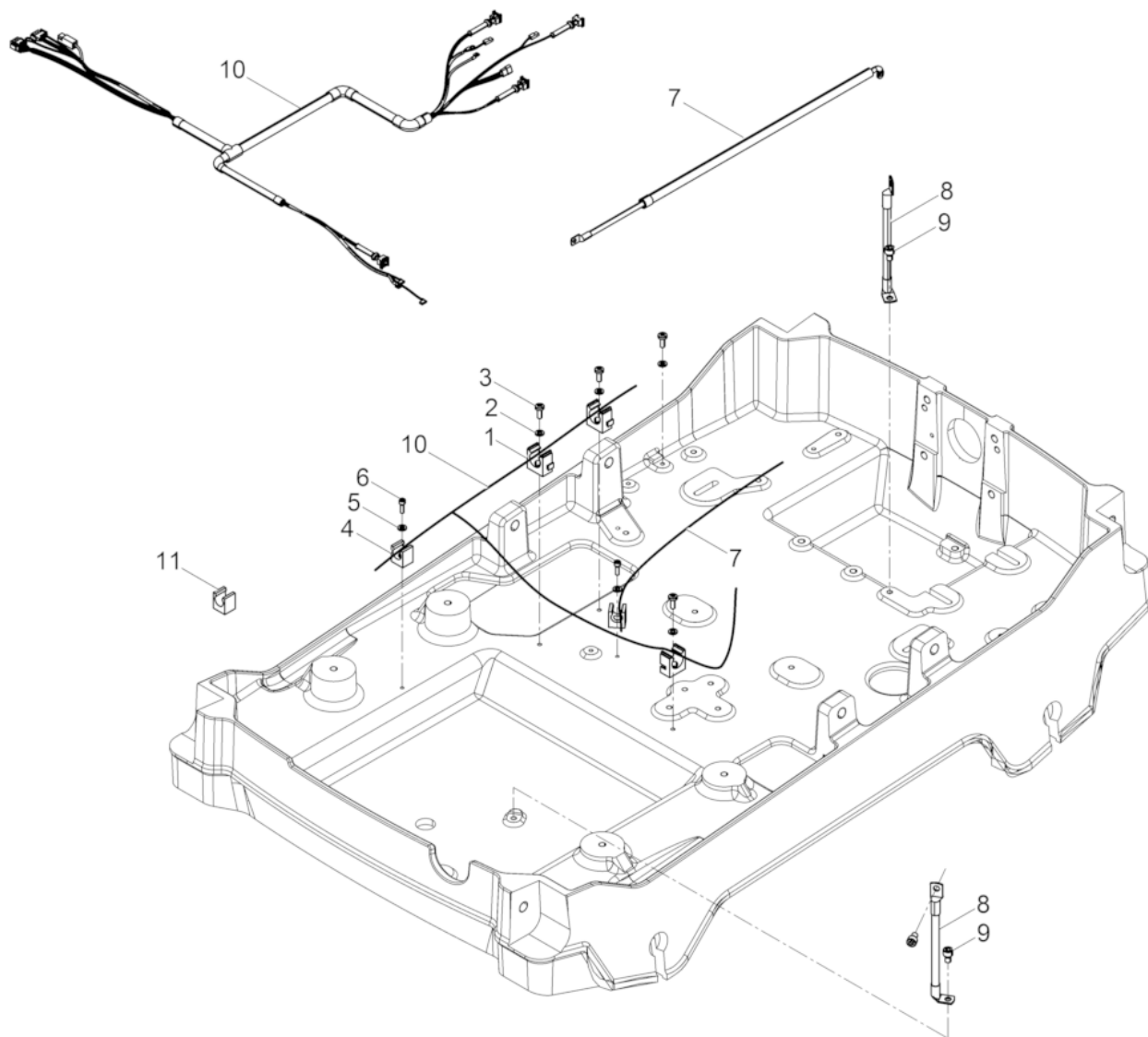

Ref. Pos.	Part No. Artikel Nr.	Qty. St.	Description Beschreibung	Descripción Description	Measurement/Abm.	Norm
					Torque/Drehm.	Sealant Schmierstoff
1	0210107	3	Clamp Schlauchklemme	Abrazadera Collier de serrage		
2	0010624	4	Flat washer Scheibe	Arandela Rondelle		
3	0211755	4	Screw Schraube	Tornillo Vis		
4	5100010281	2	Clamp Schlauchklemme	Abrazadera Collier de serrage		
5	0010625	2	Washer Scheibe	Arandela Rondelle		
6	0011561	2	Cheese head screw Zylinderschraube	Tornillo cilíndrico Vis à tête cylindrique		
7	5100005670	1	Positive cable Plus-Pol-Leitung	Cable positivo Positive cable		
8	5100010152	2	Negative pole strap Minus-Pol-Leitung	Cable polo negativo Ligne borne négative		
9	0013574	3	Cheese head screw Zylinderschraube	Tornillo cilíndrico Vis à tête cylindrique	25Nm/18ft.lbs	
10	5100005669	1	Cable harness Engine Kabelbaum Motor	Disp. del cable de elevaciónMotor Faisceau de câbles Moteur		
11	5100017849	1	Clamp Klebeschelle	Abrazadera Collier		

Tank - Radiator DPU110

Tank - Kühler DPU110

Tanque - Radiador DPU110

Réservoir - Radiateur DPU110

DPU110Lec870

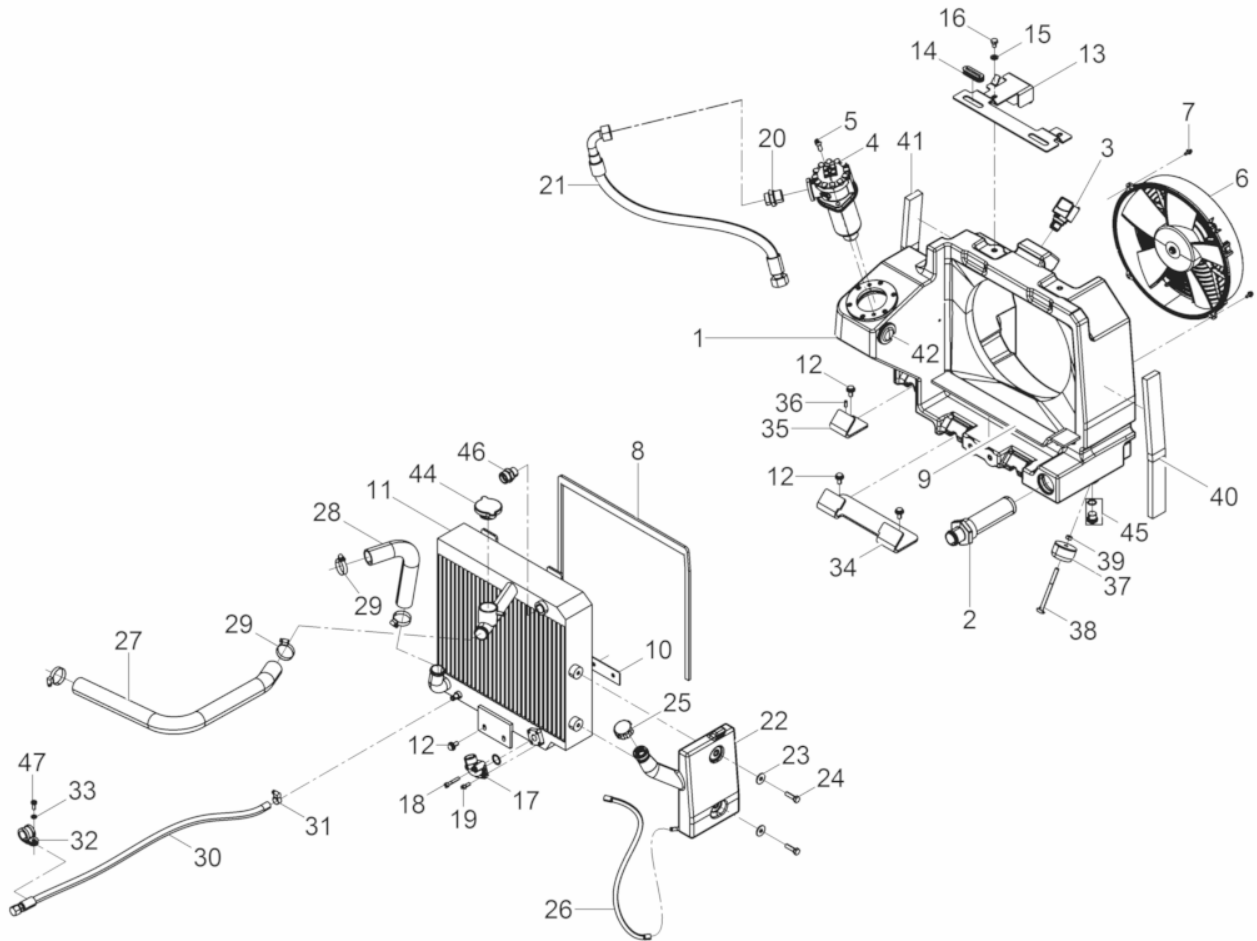

Ref. Pos.	Part No. Artikel Nr.	Qty. St.	Description Beschreibung	Descripción Description	Measurem./Abm.	Norm
					Torque/Drehm.	Sealant Schmierstoff
1	5100005485	1	Hydraulic Tank Hydrauliktank	Tanque Hidráulico Réservoir Hydraulique		
2	5100010301	1	Filter Element Filterelement	Elemento del Filtro Élément du Filtre		
3	5100010303	1	Filter Element Filterelement	Elemento del Filtro Élément du Filtre		
4	5100010302	1	Return filter Rücklauffilter	Filtro de retorno Filtre de retour		
5	0012629	2	Cheese head screw Zylinderschraube	Tornillo cilíndrico Vis à tête cylindrique	25Nm/18ft.lbs	
6	5100010341	1	Fan Elektrolüfter	Ventilador Ventilateur		
7	5100015757	4	Hexagonal head cap screw Sechskantschraube	Tornillo hexagonal Vis à tête hexagonale		
8	5100016477	1	Gasket Dichtung	Junta Joint		
9	5100016479	1	Gasket Dichtung	Junta Joint		
10	5100015887	1	Plate Blech	Chapa Tôle		
11	5100005486	1	Radiator Kühler	Radiador Radiateur		
12	0211795	5	corrugated-head screw Sicherungsschraube	Tornillo Vis		
13	5100014131	1	Bracket Halter	Soporte Support		
14	5100010830	2	Cable passage Durchführungstülle	Boquilla de paso Douille de passage		
15	0010622	2	Flat washer Scheibe	Arandela Rondelle		
16	0012360	2	Hexagonal head cap screw Sechskantschraube	Tornillo hexagonal Vis à tête hexagonale	25Nm/18ft.lbs	
17	5100010161	1	Bolted connection Winkelflanschverschraubung	Atornilladura Fixation à bride angulaire		
18	0011548	2	Cheese head screw Zylinderschraube	Tornillo cilíndrico Vis à tête cylindrique	10Nm/7ft.lbs	
19	0011553	2	Cheese head screw Zylinderschraube	Tornillo cilíndrico Vis à tête cylindrique	10Nm/7ft.lbs	
20	5100011096	1	Screwed socket Einschraubstutzen	Empalme roscado Manchon visse		
21	5100010253	1	Hose pipe Schlauchleitung	Conducto flexible Conduite flexible		
22	5100009849	1	Bottle-overflow Überlaufflasche	Botella de rebose Bouteille de trop-plein		
23	0010374	2	Flat washer Scheibe	Arandela Rondelle		
24	0011456	2	Hexagonal head cap screw Sechskantschraube	Tornillo hexagonal Vis à tête hexagonale	25Nm/18ft.lbs	
25	5100015982	1	Cover Deckel	Tapa Couvercle		

Tank - Radiator DPU110

Tank - Kühler DPU110

Tanque - Radiador DPU110

Réservoir - Radiateur DPU110

DPU110Lec870

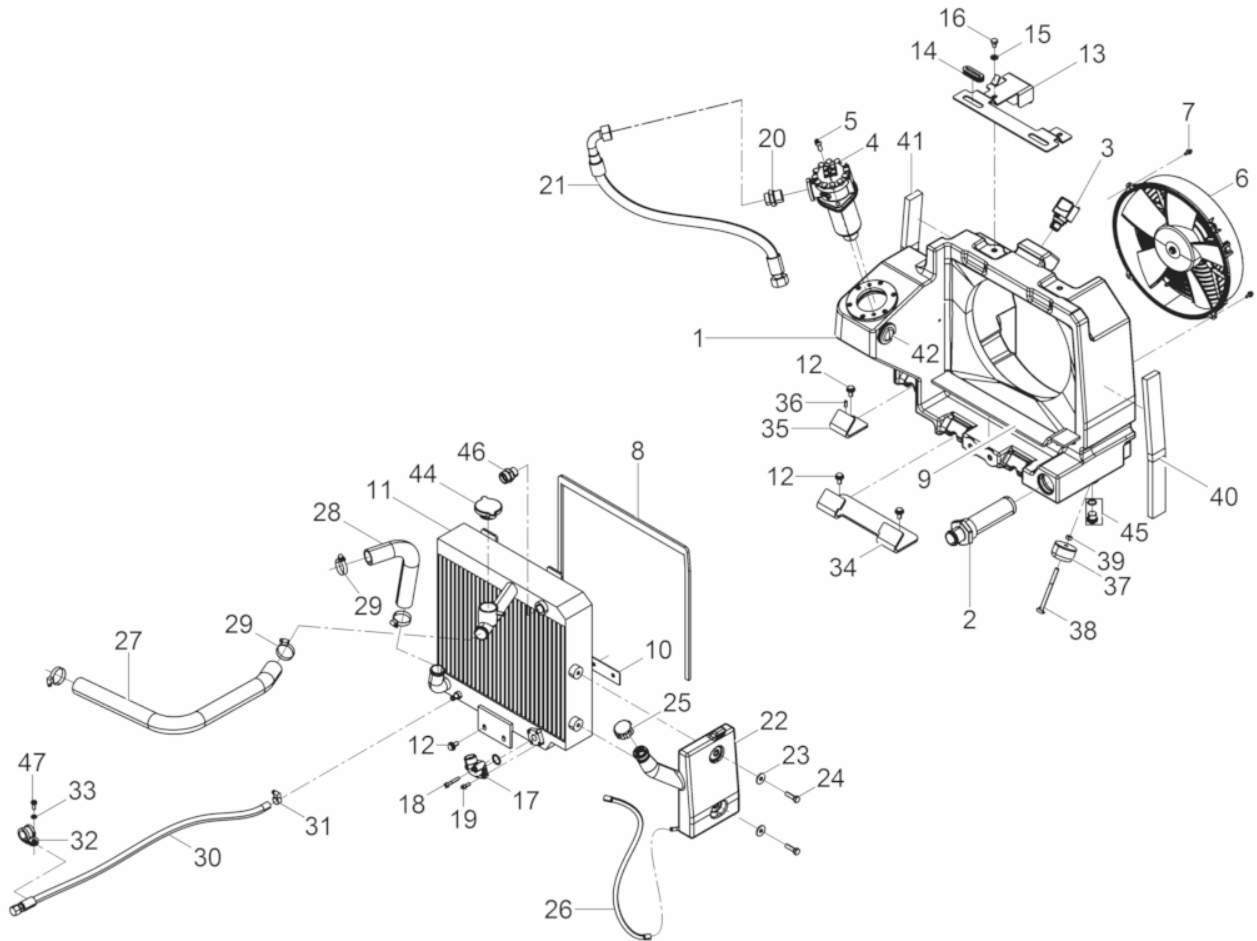

Ref. Pos.	Part No. Artikel Nr.	Qty. St.	Description Beschreibung	Descripción Description	Measurem./Abm.	Norm
					Torque/Drehm.	Sealant Schmierstoff
26	5100015647	1	radiator hose Kühlerschlauch	Manguera de combustible Tuyau à essence		
27	5100006060	1	Water Hose Wasserschlauch	Manguera de agua Tuyau d'eau		
28	5100006059	1	Water Hose Wasserschlauch	Manguera de agua Tuyau d'eau		
29	2004724	4	Worm drive house clip Schneckenwindeschelle	Abrazadera con sinfín Collier de serrage		
30	5100010256	1	Hose pipe cpl. Schlauchleitung kpl.	Conducto flexible cpl. Conduite flexible cpl.		
31	0016836	1	Clamp Schneckenwindeschelle	Abrazadera Agrafe		
32	0206551	1	Clamp Rohrschelle	Abrazadera Agrafe		
33	0010624	1	Flat washer Scheibe	Arandela Rondelle		
34	5100010567	1	Bracket Halter	Soporte Support		
35	5100010568	1	Bracket Halter	Soporte Support		
36	0097656	1	Roll pin Spannstift	Pasador Goupille de tension		
37	5100009991	2	Shockmount Gummipuffer	Tope caucho-metal Tampon oscillant		
38	5100015096	2	hammer head bolt Hammerschraube m. Nase	tornillo con cabeza demartillo vis à tête rectangulaire		
39	0010882	2	Hexagon nut Sechskantmutter	Tuerca hexagonal Écrou hexagonal		
40	5100016491	1	Gasket Dichtung	Junta Joint		
41	5100016492	1	Gasket Dichtung	Junta Joint		
42	1000262373	1	view glass Schauglas	crystal de observación jauge de niveau		
44	5100011421	1	Cover (bayonet lock) Deckel (Bajonettverschluss)	Tapa (cierre de bayoneta) Couvercle (fermeture à baïonne)		
45	5100015762	1	Plug (threaded) Verschlußschraube	Tapón roscado Bouchon		
46	0063739	1	Screw socket Einschraubstutzen	Empalme roscado Manchon visse		DIN3901
47	0211755	1	Screw Schraube	Tornillo Vis		

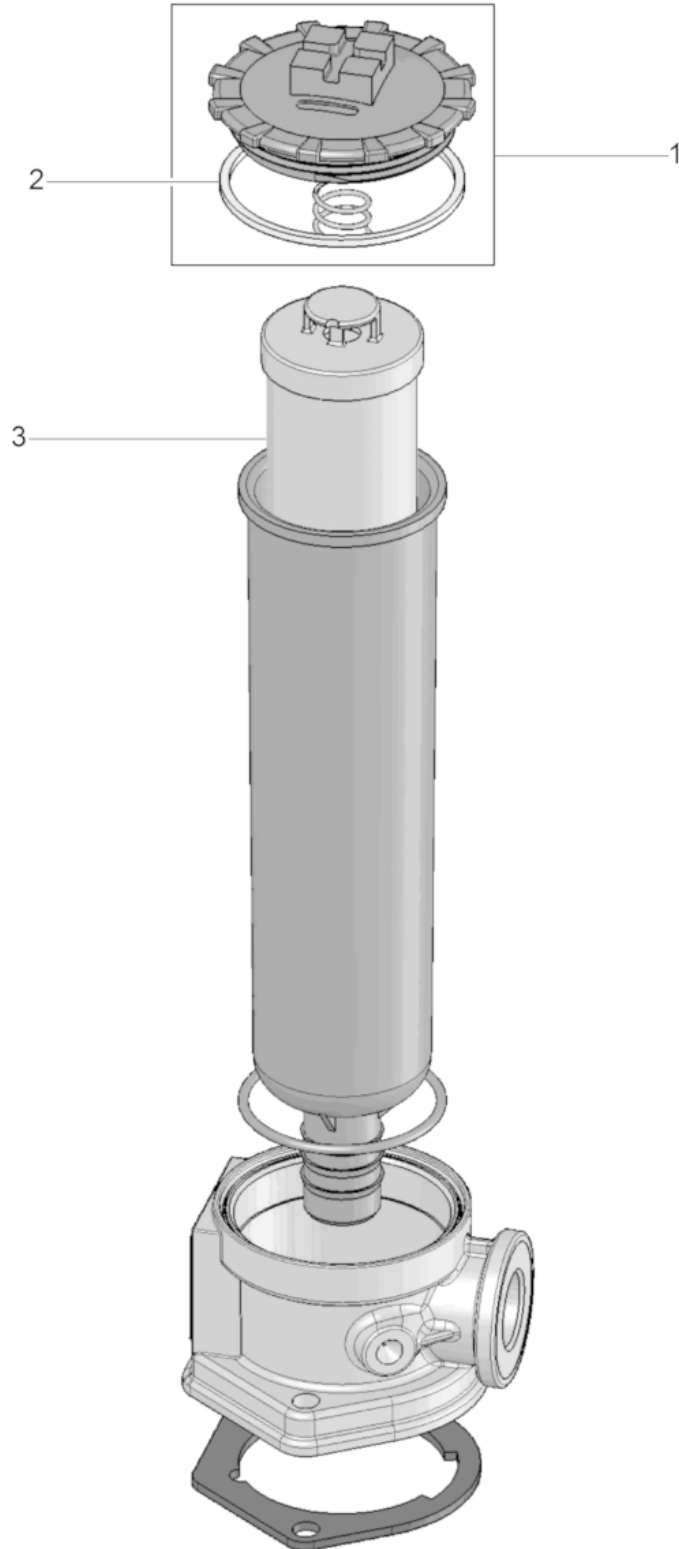

Ref. Pos.	Part No. Artikel Nr.	Qty. St.	Description Beschreibung	Descripción Description	Measurem./Abm.	Norm
					Torque/Drehm.	Sealant Schmierstoff
1	0220217	1	Cover Deckel kpl.	Tapa Couvercle		
2	0220218	1	Gasket Dichtung	Junta de estanqueidad Garniture		
3	5100016998	1	Filter Element Filterelement	Elemento del Filtro Élément du Filtre		

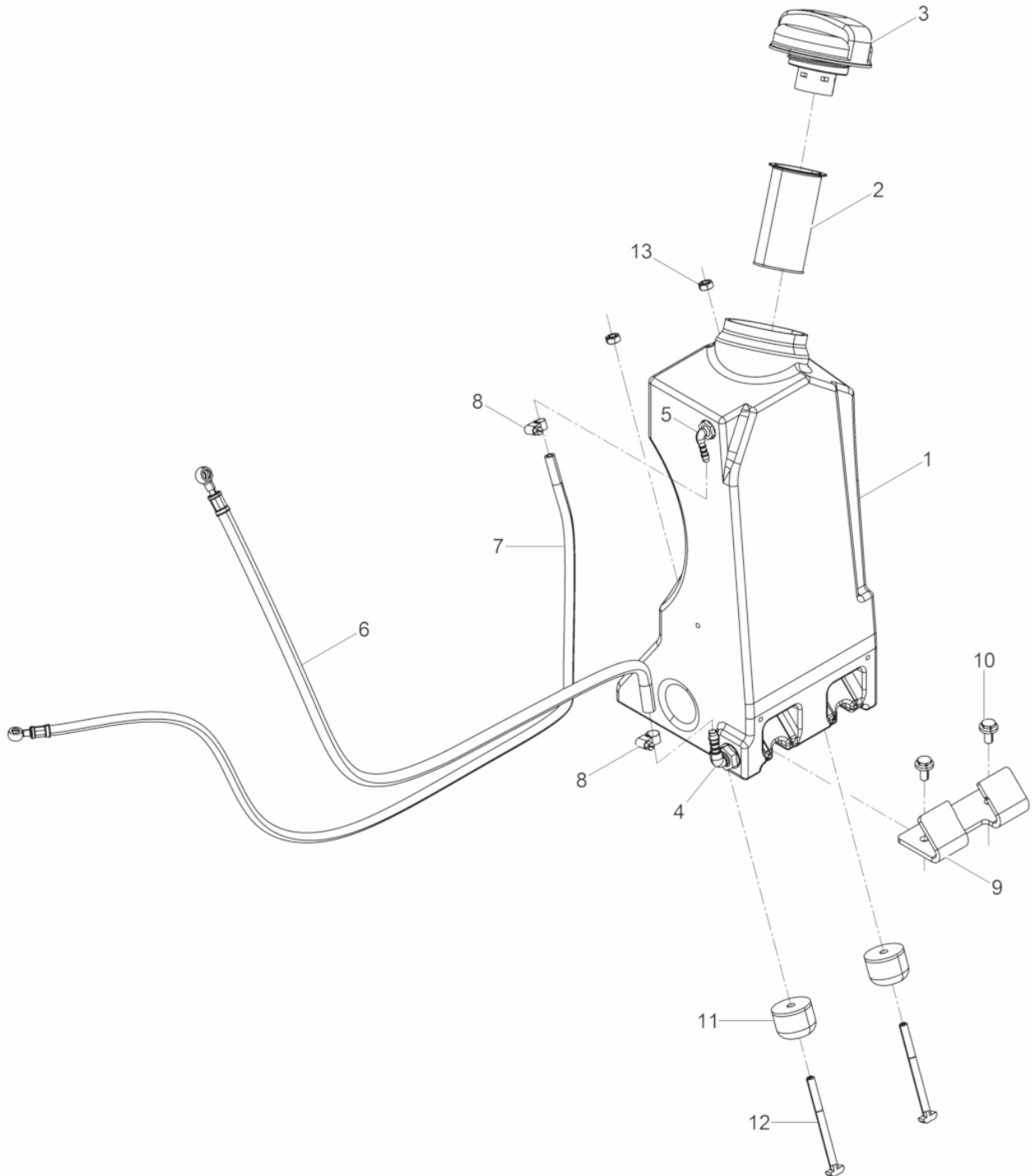

Ref. Pos.	Part No. Artikel Nr.	Qty. St.	Description Beschreibung	Descripción Description	Measurement/Abm.	Norm
					Torque/Drehm.	Sealant Schmierstoff
1	5100038039	1	Fuel Tank Kraftstofftank	Depósito de Combustible Réservoir à Essence		
2	1000267866	1	Screen Einfüllsieb	Criba de llenado Crible		
3	5100010476	1	Tank cover Tankdeckel	Tapa de tanque Couvercle du réservoir		
4	1000051394	1	Angle cut piece Winkelstutzen	Tubuladura angular Tubulure d'angle		
5	5100010035	1	elbow fitting cpl. Winkelstutzen kpl.	tubuladura angular cpl. Raccord cpl.		
6	5100010244	1	Fuel hose Kraftstoffleitung	Manguera de combustible Tuyau à essence		
7	5100010245	1	Fuel hose Kraftstoffleitung	Manguera de combustible Tuyau à essence		
8	0016836	2	Clamp Schneckengewindeschelle	Abrazadera Agrafe	3Nm/2ft.lbs	
9	5100010569	1	Bracket Halter	Soporte Support		
10	0211795	2	corrugated-head screw Sicherungsschraube	Tornillo Vis	35Nm/26ft.lbs	
11	5100009992	2	Shockmount Gummipuffer	Tope caucho-metal Tampon oscillant		
12	5100015096	2	hammer head bolt Hammerschraube m. Nase	tornillo con cabeza demartillo vis à tête rectangulaire		
13	0010882	2	Hexagon nut Sechskantmutter	Tuerca hexagonal Écrou hexagonal	6Nm/4ft.lbs	

Block-Hydraulic cpl. DPU80/110
Hydraulikblock kpl. DPU80/90/110
Bloque Hidráulico cpl. DPU80/110
Bloc Hydraulique cpl.

DPU110Lec870

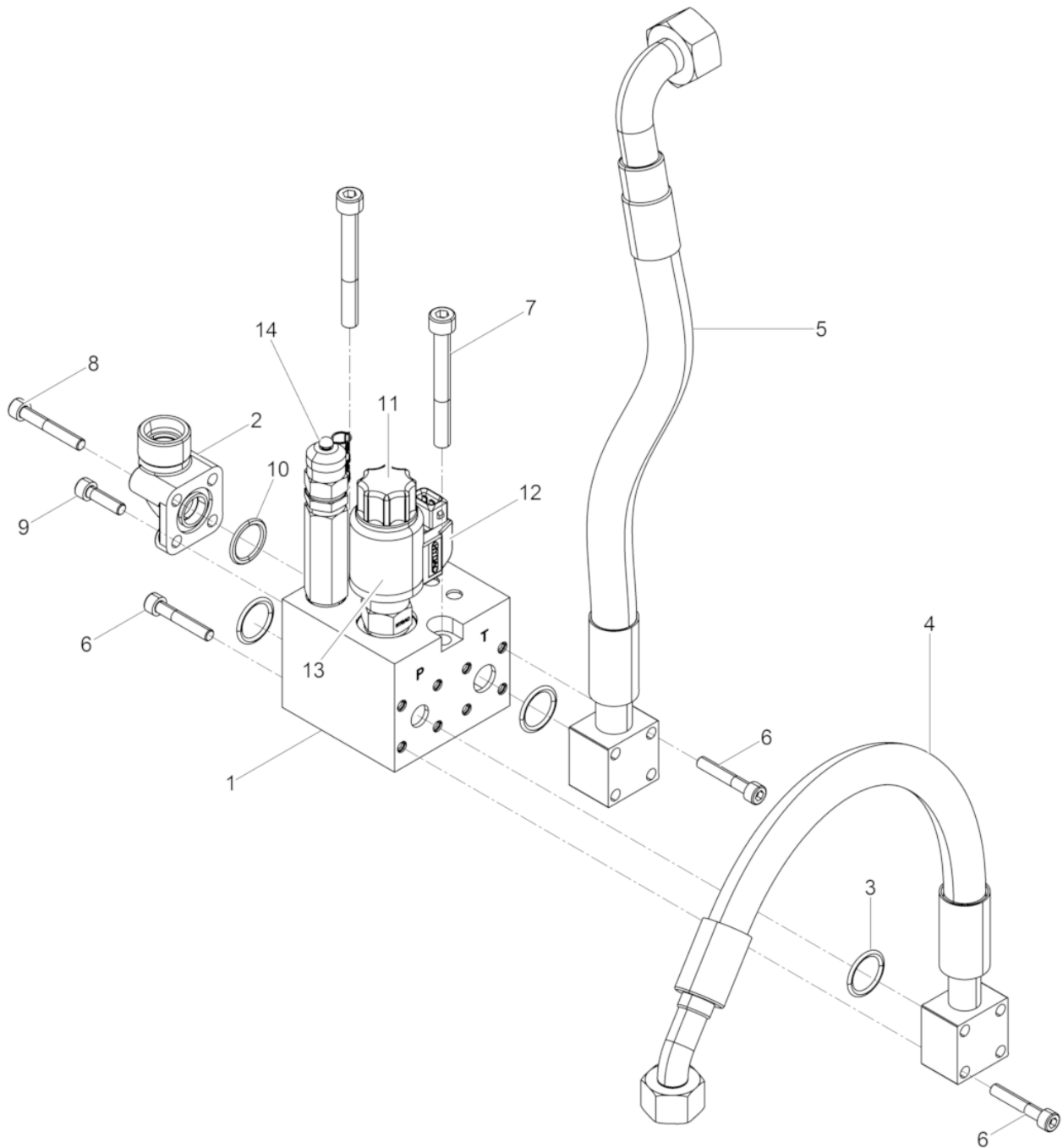

Ref. Pos.	Part No. Artikel Nr.	Qty. St.	Description Beschreibung	Descripción Description	Measur./Abm.	Norm
					Torque/Drehm.	Sealant Schmierstoff
1	5100005479	1	Block-Hydraulic Hydraulikblock	Bloque Hidráulico Bloc Hydraulique		
2	5100010161	1	Bolted connection Winkelflanschverschraubung	Atornilladura Fixation à bride angulaire		
3	0210116	3	O-Ring O-Ring	Anillo-O Joint torique		
4	5100010247	1	Hose pipe Schlauchleitung	Conducto flexible Conduite flexible		
5	5100010251	1	Hose pipe Schlauchleitung	Conducto flexible Conduite flexible		
6	0011548	12	Cheese head screw Zylinderschraube	Tornillo cilíndrico Vis à tête cylindrique	10Nm/7ft.lbs	
7	0013576	2	Cheese head screw Zylinderschraube	Tornillo cilíndrico Vis à tête cylindrique	25Nm/18ft.lbs	
8	0011547	2	Cheese head screw Zylinderschraube	Tornillo cilíndrico Vis à tête cylindrique	10Nm/7ft.lbs	
9	0012373	2	Cheese head screw Zylinderschraube	Tornillo cilíndrico Vis à tête cylindrique	10Nm/7ft.lbs	
10	1000090406	1	O-ring O-ring	Anillo en forma de o Joint torique		
11	0220194	1	Valve cap Ventilkappe	Casquete de válvula Joint de soupape		
12	5100025061	1	Valve Ventil	Válvula Soupape		
13	5100025062	1	Solenoid Magnetspule	Solenoid Solénoide		
14	0220198	1	Test port Messanschluss	Conexión de medición Raccordement		

Diesel Engine cpl. DPU110
Dieselmotor kpl. DPU110
Motor Diesel cpl. DPU110
Moteur Diesel cpl. DPU110

DPU110Lec870

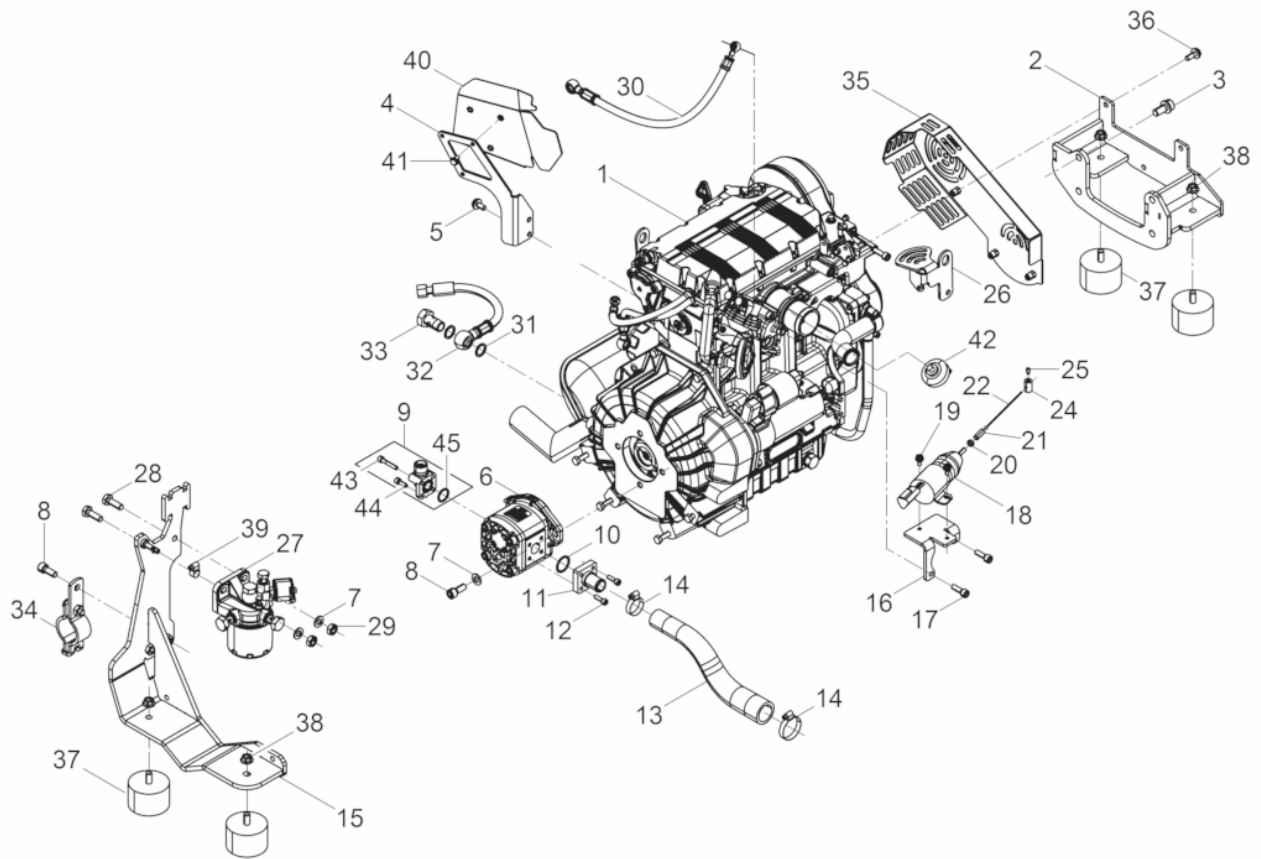

Ref. Pos.	Part No. Artikel Nr.	Qty. St.	Description Beschreibung	Descripción Description	Measur./Abm.	Norm
					Torque/Drehm.	Sealant Schmierstoff
1	5100005722	1	Diesel engine KDW 1003 (DPU110) Dieselmotor KDW 1003 (DPU110)	Motor diesel KDW 1003 (DPU110) Moteur diesel KDW 1003		
1	5100005723	1	Diesel engine KDW 1003 US (DPU110 US) Dieselmotor KDW 1003 US (DPU110 US)	Motor diesel KDW 1003 US (DPU110 US) Moteur diesel KDW 1003 US		
2	5100005758	1	Engine Support cpl. Motorträger kpl.	Montaje del Motor cpl. Montage du Moteur cpl.		
3	0210165	4	corrugated-head screw Sicherheitsschraube	Tornillo Vis		
4	5100011317	1	Bracket Halter	Soporte Support		
5	0211795	2	corrugated-head screw Sicherheitsschraube	Tornillo Vis		
6	5100015729	1	Gear pump Zahnradpumpe	Bomba de engranajes Pompe d'engrenages		
7	0010621	4	Washer Scheibe	Arandela Rondelle		
8	0011535	3	Cheese head screw Zylinderschraube	Tornillo cilíndrico Vis à tête cylindrique	49Nm/36ft.lbs	
9	5100046101	1				
10	0210115	1	O-Ring O-Ring	Anillo-O Joint torique		
11	5100010059	1	Hose connection Schlauchstutzen	Racord de manguera Bride d'aspiration		
12	0011551	4	Cheese head screw Zylinderschraube	Tornillo cilíndrico Vis à tête cylindrique	10Nm/7ft.lbs	
13	5100010056	1	Suction hose Ansaugschlauch	Manguera de succión Tuyau de succion		
14	2004724	2	Worm drive house clip Schneckenwindeschelle	Abrazadera con sinfín Collier de serrage		
15	5100005748	1	Engine Support cpl. Motorträger kpl.	Montaje del Motor cpl. Montage du Moteur cpl.		
16	0204549	1	Bracket Halter	Soporte Équerre		
17	0011542	2	Cheese head screw Zylinderschraube	Tornillo cilíndrico Vis à tête cylindrique	25Nm/18ft.lbs	
18	0155486	1	Throttle Actuator Gasreglerstellteil	Actuador de Acelerador Dispositif de commande des gaz		
19	5100010512	3	corrugated-head screw Sicherheitsschraube	Tornillo Vis		
20	0010880	1	Hexagon nut Sechskantmutter	Tuerca hexagonal Écrou hexagonal		
21	0155487	1	Adaptor Adapter	Adaptador Adaptateur		
22	0150022	1	Cable Kabel	Cable Câble		
24	0119695	1	Collar Hülse	Collar Douille		
25	5100009861	1	Threaded pin Gewindestift	Varilla roscada Goupille fileté		

Diesel Engine cpl. DPU110
Dieselmotor kpl. DPU110
Motor Diesel cpl. DPU110
Moteur Diesel cpl. DPU110

DPU110Lec870

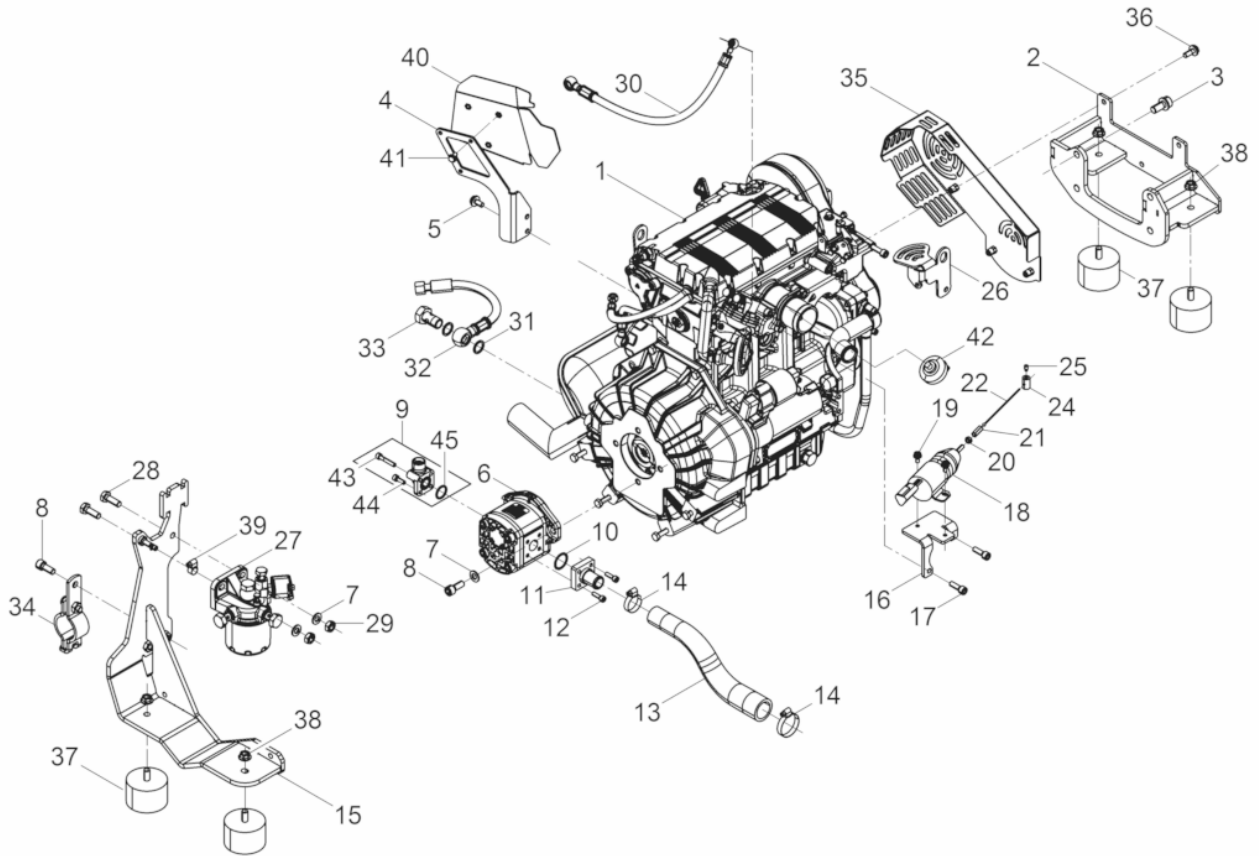

Ref. Pos.	Part No. Artikel Nr.	Qty. St.	Description Beschreibung	Descripción Description	Measur./Abm.	Norm
					Torque/Drehm.	Sealant Schmierstoff
26	5100010901	1	Covering Abdeckung	Cubierta Cubierta		
27	0215484	1	Fuel Filter Kraftstofffilter	Filtro de Combustible Filtre à Carburant		
27	5000210173	1	Filter-fuel cpl. Kraftstofffilter kpl.	Filtro de combustible cpl. re à carburant cpl.		
28	0011439	2	Hexagonal head cap screw Sechskantschraube	Tornillo hexagonal Vis à tête hexagonale	49Nm/36ft.lbs	
29	0010883	2	Hexagon nut Sechskantmutter	Tuerca hexagonal Écrou hexagonal		
30	5100010246	1	Fuel hose Kraftstoffleitung	Manguera de combustible Tuyau à essence		
31	0019156	2	Gasket Dichtring	Anillo de junta Bague d'étanchéité		
32	5100010257	1	Hose pipe Schlauchleitung	Conducto flexible Conduite flexible		
33	0207336	1	Hollow screw Hohlschraube	Tornillo hueco Boulon creux à filet femelle		
34	5100011327	1	Pipe clamp Rohrschelle	Abrazadera Collier pour tuyau		
35	5100010740	1	Belt guard cpl. Keilriemenschutz kpl.	Protección de la polea cpl. Protection de courroie cpl.		
36	5100018058	4	corrugated-head screw Sicherungsschraube	tornillo de seguridad vis de sécurité		
37	5100000973	4	Shockmount Gummi-Metall-Puffer	Amortiguador Silentbloc		
38	0216640	4	Locknut Sicherungsmutter	Contratuerca Contre-écrou		
39	0016836	1	Clamp Schneckengewindeschelle	Abrazadera Agrafe		
40	5100024279	1	Heat shield cpl. Hitzeschild kpl.	Pantalla térmica cpl. Écran thermique cpl.		
41	0210194	3	corrugated-head screw Sicherungsschraube	Tornillo Vis		
42	0206422	1	Switch Wartungsschalter	Interruptor Interrupteur		
43	0011548	2	Cheese head screw Zylinderschraube	Tornillo cilíndrico Vis à tête cylindrique		
44	0011552	2	Cheese head screw Zylinderschraube	Tornillo cilíndrico Vis à tête cylindrique	M6 x 18 10Nm/7ft.lbs	ISO4762
45	0210116	1	O-Ring O-Ring	Anillo-O Joint torique		

Holder cpl.
Halter kpl.
Soporte cpl.
Attache cpl.

DPU110Lec870

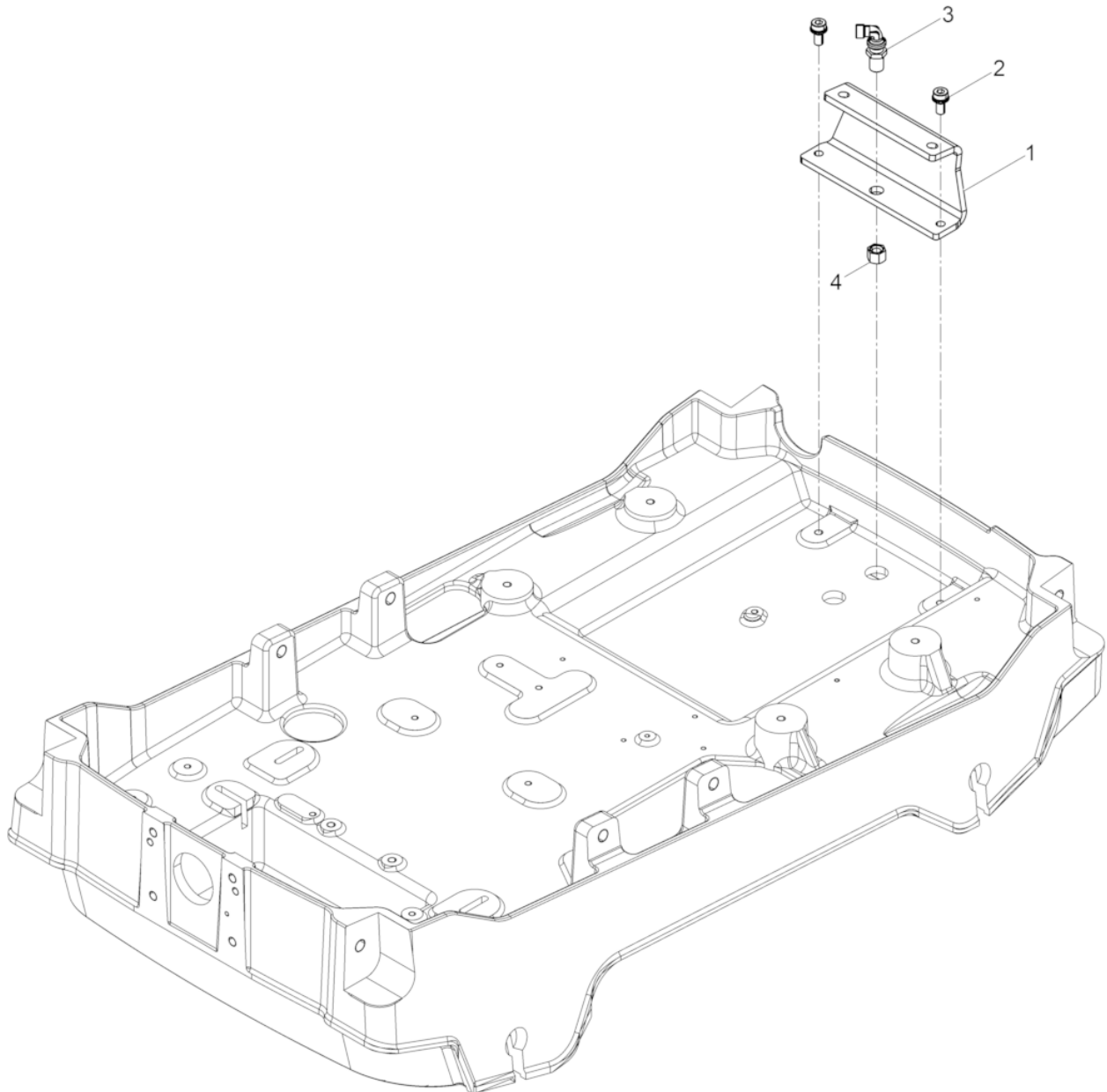

Ref. Pos.	Part No. Artikel Nr.	Qty. St.	Description Beschreibung	Descripción Description	Measurement./Abm.	Norm
					Torque/Drehm.	Sealant Schmierstoff
1	5100010590	1	Bracket Halter	Soporte Support		
2	0210111	2	corrugated-head screw Sicherungsschraube	Tornillo Vis	90Nm/66ft.lbs	
3	0205238	1	Screw connection Winkel-Schottverschraubung	Atornilladura Raccord vis		
4	0211773	1	Nose cap Verschlusskappe	Tapa de cierre Chape de fermeture	40Nm/30ft.lbs	

Elektrobox kpl. DPU80/90/110
Elektrobox kpl. DPU80/90/110
Caja eléctrica cpl. DPU80/90/110
Coffret électrique cpl.

DPU110Lec870

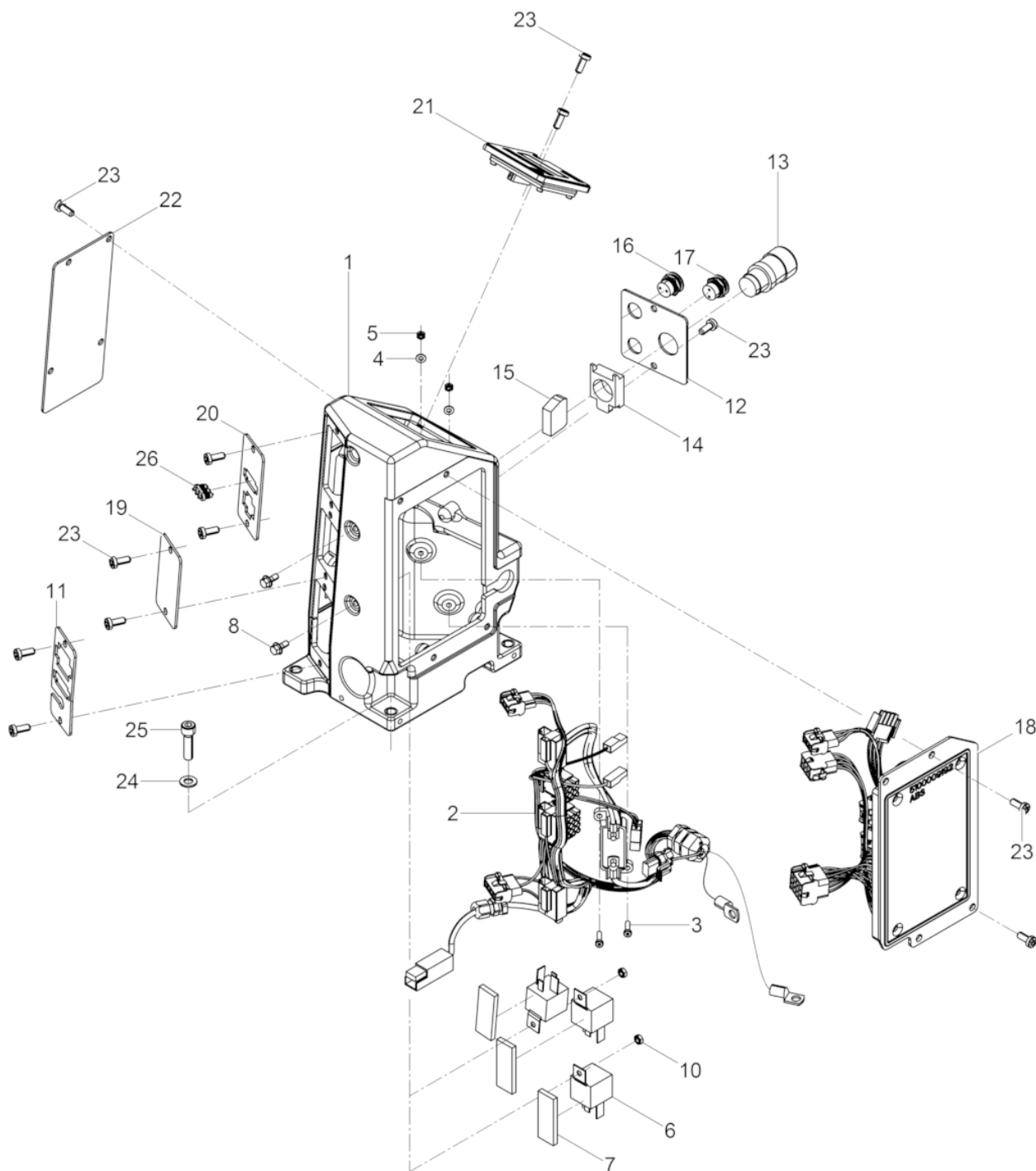

Ref. Pos.	Part No. Artikel Nr.	Qty. St.	Description Beschreibung	Descripción Description	Measurem./Abm.	Norm
					Torque/Drehm.	Sealant Schmierstoff
1	5100005376	1	Electric components drawer Elektrobox	Caja eléctrica Coffret électrique		
2	5100010129	1	Cable harness E-Box Kabelbaum E-Box	Disp. del cable de elevación Caja eléctrica Faisceau de câbles		
3	0011570	2	Cheese head screw Zylinderschraube	Tornillo cilíndrico Vis à tête cylindrique	5Nm/4ft.lbs	
4	0010628	2	Flat washer Scheibe	Arandela Rondelle		
5	0010370	2	Hexagon nut Sechskantmutter	Tuerca hexagonal Écrou hexagonal		
6	0085437	3	Relay Relais	Relai Relais		
7	5100016686	3	Gasket Dichtung	Junta Joint		
8	5100015757	2	Hexagonal head cap screw Sechskantschraube	Tornillo hexagonal Vis à tête hexagonale	10Nm/7ft.lbs	
10	0010369	2	Hexagon nut Sechskantmutter	Tuerca hexagonal Écrou hexagonal		
11	5100010300	1	Connector plate bottom Steckerblech unten	chapa enchufe abajo tôle d'enchicage en bas		
12	5100010315	1	Plate Not-Aus Blech	Chapa Tôle		
13	5100010121	1	Control Betätigung	Regulador Commande		
14	5100010109	1	Flange Befestigungsflansch	Brida Bride		
15	5100010110	1	Switch Hilfsschalter	Interruptor Interrupteur		
16	5100005715	1	Botton switch Drucktaster	Interruptor a pulsador Interrupteur de pression		
17	5100010070	1	Botton switch Drucktaster	Interruptor a pulsador Interrupteur de pression		
18	5100005762	1	Decoder cpl. Decoder kpl.	Decodificador cpl. Décodeur cpl.		
19	5100010780	1	Connector plate middle Steckerblech mitte	chapa enchufe centro tôle d'enchicage centre		
20	5100010781	1	Connector plate top Steckerblech oben	chapa de enchufe superior tôle d'enchicage haut		
21	5100009818	1	Display Anzeigeeinheit	Cuadro indicador Afficheur, écran		
22	5100005471	1	Cover Deckel	Tapa Couvercle		
23	0108371	18	Oval head screw Linsenkopfschraube	Tornillo gota de sebo Vis noyée lentiforme		
24	0010622	3	Flat washer Scheibe	Arandela Rondelle		
25	0011541	3	Cheese head screw Zylinderschraube	Tornillo cilíndrico Vis à tête cylindrique	25Nm/18ft.lbs	
26	5100022411	1	Blind plug cpl. Blindstecker kpl.	Enchufe cpl. Fiche borgne cpl.		

Air filter cpl.
Luftfilter kpl.
Filtro de aire cpl.
Filtre à air cpl.

DPU110Lec870

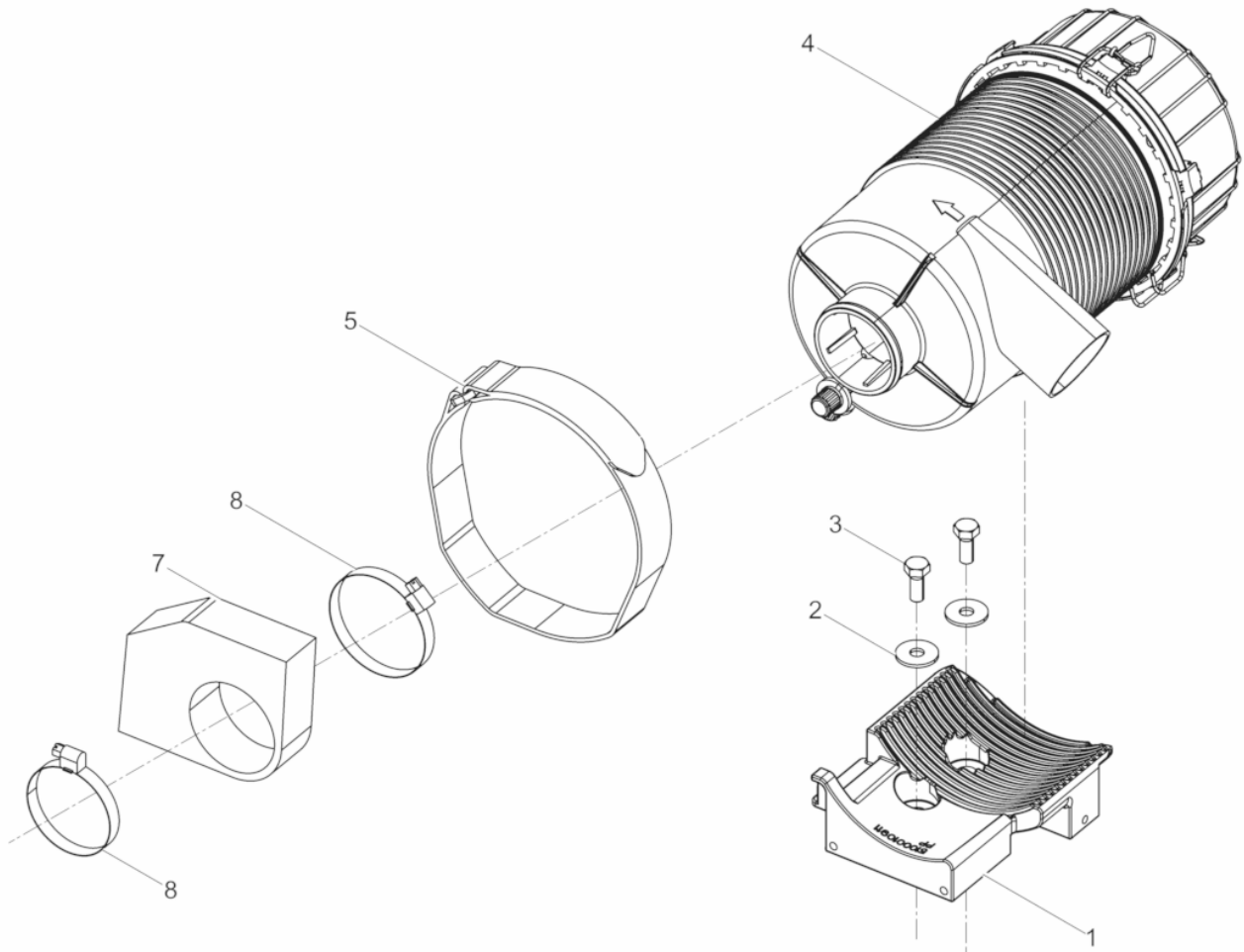

Ref. Pos.	Part No. Artikel Nr.	Qty. St.	Description Beschreibung	Descripción Description	Measurement/Abm.	Norm
					Torque/Drehm.	Sealant Schmierstoff
1	5100010911	1	Bracket Halter	Soporte Support		
2	0010374	2	Flat washer Scheibe	Arandela Rondelle		
3	0012362	2	Hexagonal head cap screw Sechskantschraube	Tornillo hexagonal Vis à tête hexagonale	25Nm/18ft.lbs	
4	5100005726	1	Air Cleaner Luftfilter	Filtro del Aire Filtre à Air		
4	5100024488	1	Filter Element Filterelement	Elemento del Filtro Élément du Filtre		
4	5100024489	1	safety elements Sicherheitselement	elemento de seguridad Élément de sécurité		
4	5100024550	3	Clamp Klemme	Abrazadera Pince		
4	5100024551	1	Dust discharge valve Staubaustrittsventil	Válvula Soupape		
5	5100010912	1	Tightening strap Spannband	Collar Bande de serrage		
7	5100016655	1	Gasket Dichtung	Junta Joint		
8	0014996	2	Clamp Schneckengewindeschelle	Abrazadera Agrafe		

Locking device rear cpl.
Verriegelung hinten kpl.

DPU110Lec870

Dispositivo de bloqueo atrás cpl.
Dispositif de verrouillage

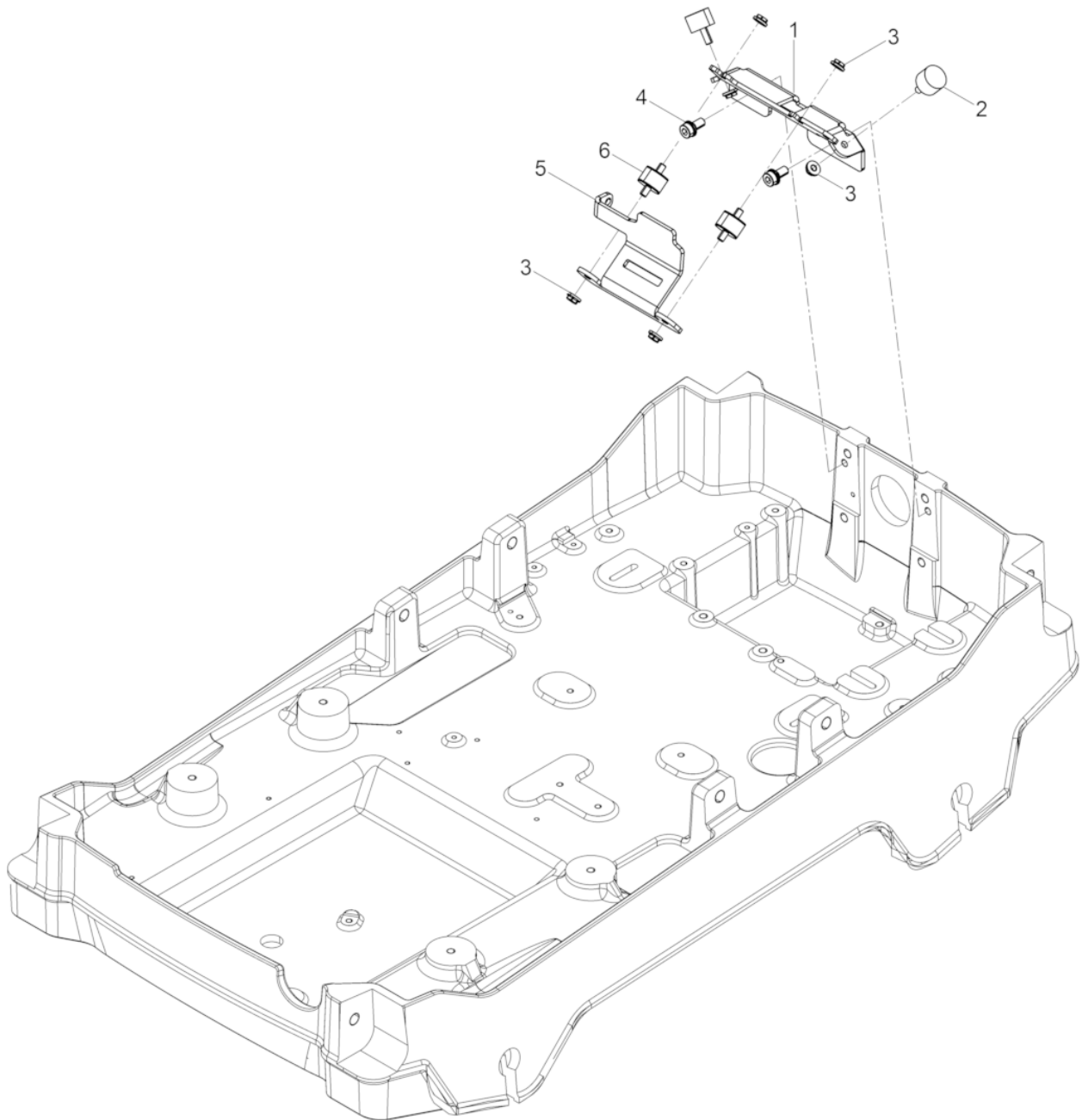

Ref. Pos.	Part No. Artikel Nr.	Qty. St.	Description Beschreibung	Descripción Description	Measurement./Abm.	Norm
					Torque/Drehm.	Sealant Schmierstoff
1	5100010584	1	Bracket Halter	Soporte Support		
2	0204116	2	Shockmount Anschlagpuffer	Amortiguador Silentbloc		
3	5100017158	6	Locknut Sicherungsmutter	Contratuerca Contre-écrou	30Nm/22ft.lbs	
4	0210111	2	corrugated-head screw Sicherungsschraube	Tornillo Vis	90Nm/66ft.lbs	
5	5100010580	1	locking lever rear Verriegelungshebel hinten	palanca de bloqueo atrás levier de verrouillage arrière		
6	5100010840	2	Shockmount Gummi-Metall-Puffer	Tope caucho-metal Tampon metallique oscillant		

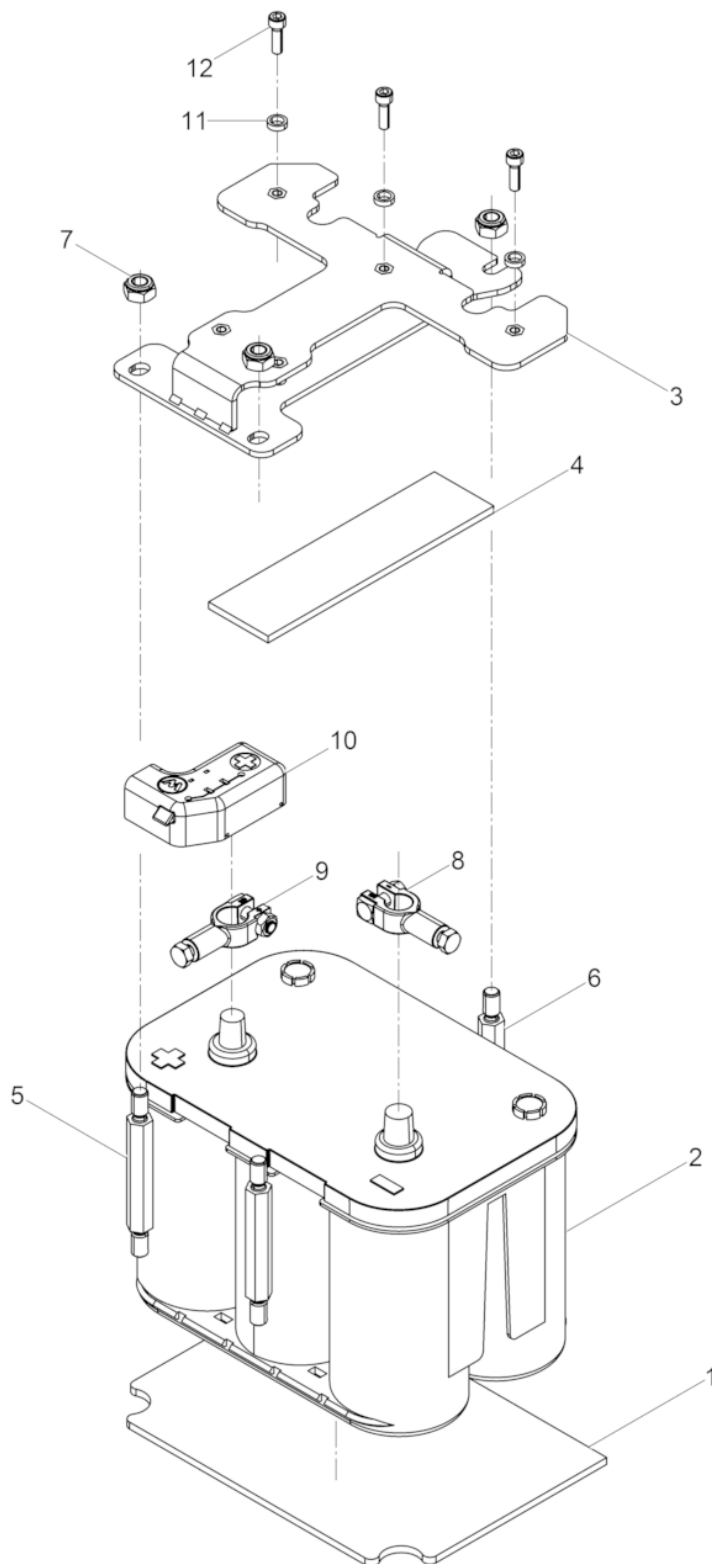

Ref. Pos.	Part No. Artikel Nr.	Qty. St.	Description Beschreibung	Descripción Description	Measurement./Abm.	Norm
					Torque/Drehm.	Sealant Schmierstoff
1	0209152	1	Insulating cushion Kissen	Almohadilla Coussin		
2	0086527	1	Battery Batterie	Batería Batterie		
3	5100005937	1	Battery mounting cpl. Batteriehalterung kpl.	Montaje de batería cpl. Fixation de batterie cpl.		
4	5100017160	1	Gasket Dichtung	Junta Joint		
5	5100010891	1	Threaded bolt Gewindebolzen	Perno roscado Boulon fileté	25Nm/18ft.lbs	
6	5100010892	2	Threaded bolt Gewindebolzen	Perno roscado Boulon fileté	25Nm/18ft.lbs	
7	0017313	3	Hexagon nut Sechskantmutter	Tuerca hexagonal Écrou hexagonal	25Nm/18ft.lbs	
8	5100015203	1	pole terminal negative Polklemme Minuspol	terminal de polo negativo borne polaire negative		
9	5100015202	1	pole terminal positive Polklemme Pluspol	terminal de polo positivo borne polaire positive		
10	5100014022	1	Positive pol cover Pluspolabdeckung	Tapa polo positivo Couverture		
11	0212623	3	Bushing Buchse	Buje Douille		
12	0011551	3	Cheese head screw Zylinderschraube	Tornillo cilíndrico Vis à tête cylindrique	10Nm/7ft.lbs	

Protective frame cpl. DPU110

Schutzrahmen kpl. DPU110

Armazón de protección cpl. DPU110

Cadre protection cpl. DPU110

DPU110Lec870

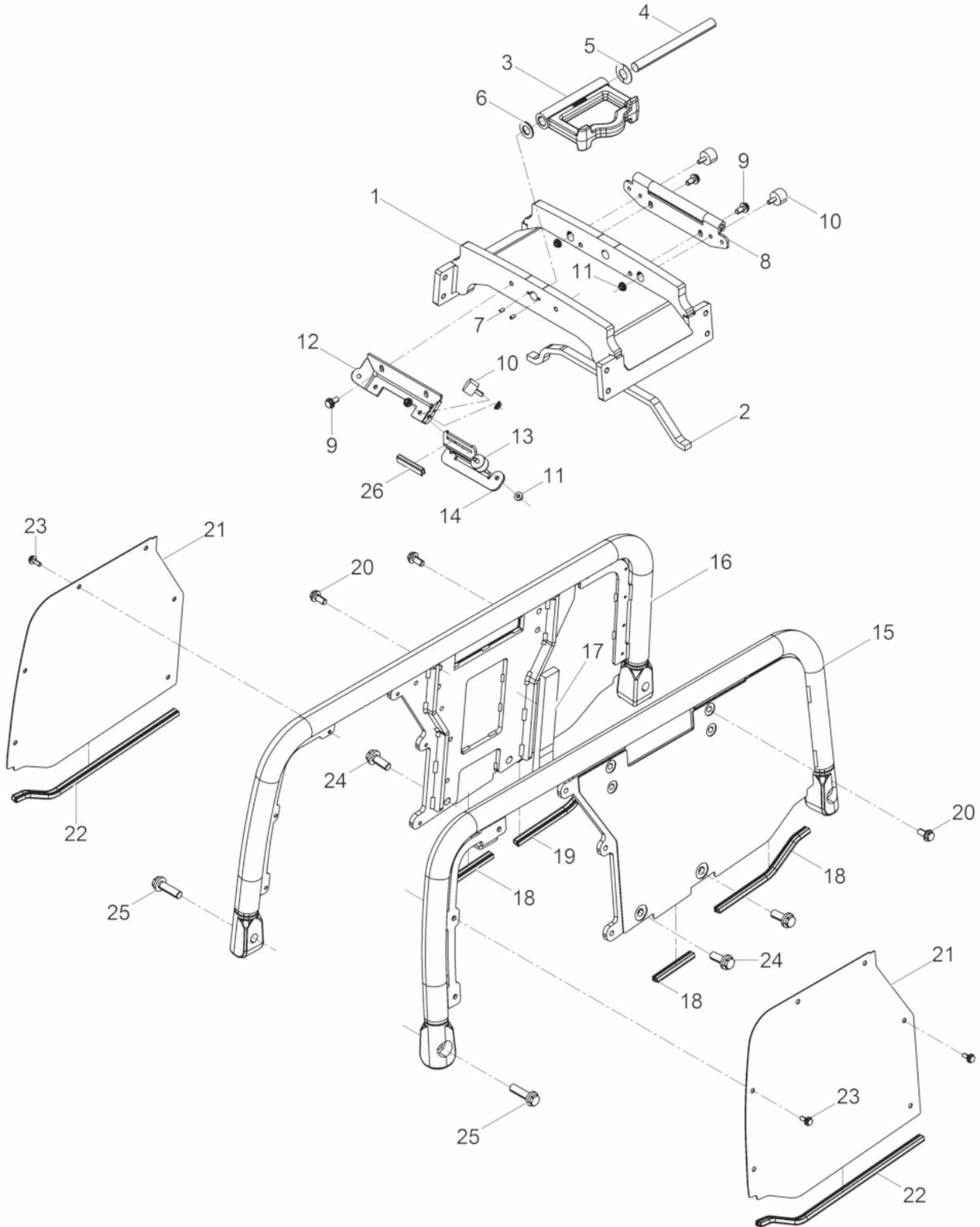

Ref. Pos.	Part No. Artikel Nr.	Qty. St.	Description Beschreibung	Descripción Description	Measurem./Abm.	Norm
					Torque/Drehm.	Sealant Schmierstoff
1	5100010527	1	Cross-beam Traverse	Viga transversal Entretoise		
2	5100016519	1	Gasket Dichtung	Junta Joint		
3	5100017413	1	Jack ring Kranöse	Ojete para grua Oeillet		
4	5100005732	1	Axle Achse	Eje Axe		
5	0202829	1	Cup spring Tellerfeder	Resorte de platillo Ressort belleville		
6	0010616	1	Flat washer Scheibe	Arandela Rondelle		
7	0126187	2	Threaded pin Gewindestift	Varilla roscada Goupille fileté		
8	5100016051	1	Hinge Scharnier	Bisagra Charnière		
9	0210112	4	corrugated-head screw Sicherungsschraube	Tornillo Vis		
10	0204116	4	Shockmount Anschlagpuffer	Amortiguador Silentbloc		
11	5100017158	8	Locknut Sicherungsmutter	Contratuerca Contre-écrou		
12	5100010583	1	Bracket Halter	Soporte Support		
13	5100010840	2	Shockmount Gummi-Metall-Puffer	Tope caucho-metal Tampon metallique oscillant		
14	5100029847	1	locking lever (front) Verriegelungshebel (vorne)	palanca de bloqueo (delantero) levier de verrouillage (avant)		
15	5100010450	1	Side Element Seitenteil	Pieza Lateral Partie Laterale		
16	5100010451	1	Side Element Seitenteil	Pieza Lateral Partie Laterale		
17	5100016517	2	Gasket Dichtung	Junta Joint		
18	5100018100	2	Edge protection Kantenschutz	Protección de cantos Protege arete		
19	5100018101	2	Edge protection Kantenschutz	Protección de cantos Protege arete		
20	5100018059	8	corrugated-head screw Sicherungsschraube	tornillo de seguridad vis de sécurité		
21	5100010459	2	Covering Abdeckung	Cubierta Couverture		
22	5100018102	2	Edge protection Kantenschutz	Protección de cantos Protege arete		
23	0211795	12	corrugated-head screw Sicherungsschraube	Tornillo Vis		
24	5100011100	4	corrugated-head screw Sicherungsschraube	tornillo de seguridad vis de sécurité		
25	5100011101	4	corrugated-head screw Sicherungsschraube	tornillo de seguridad vis de sécurité		

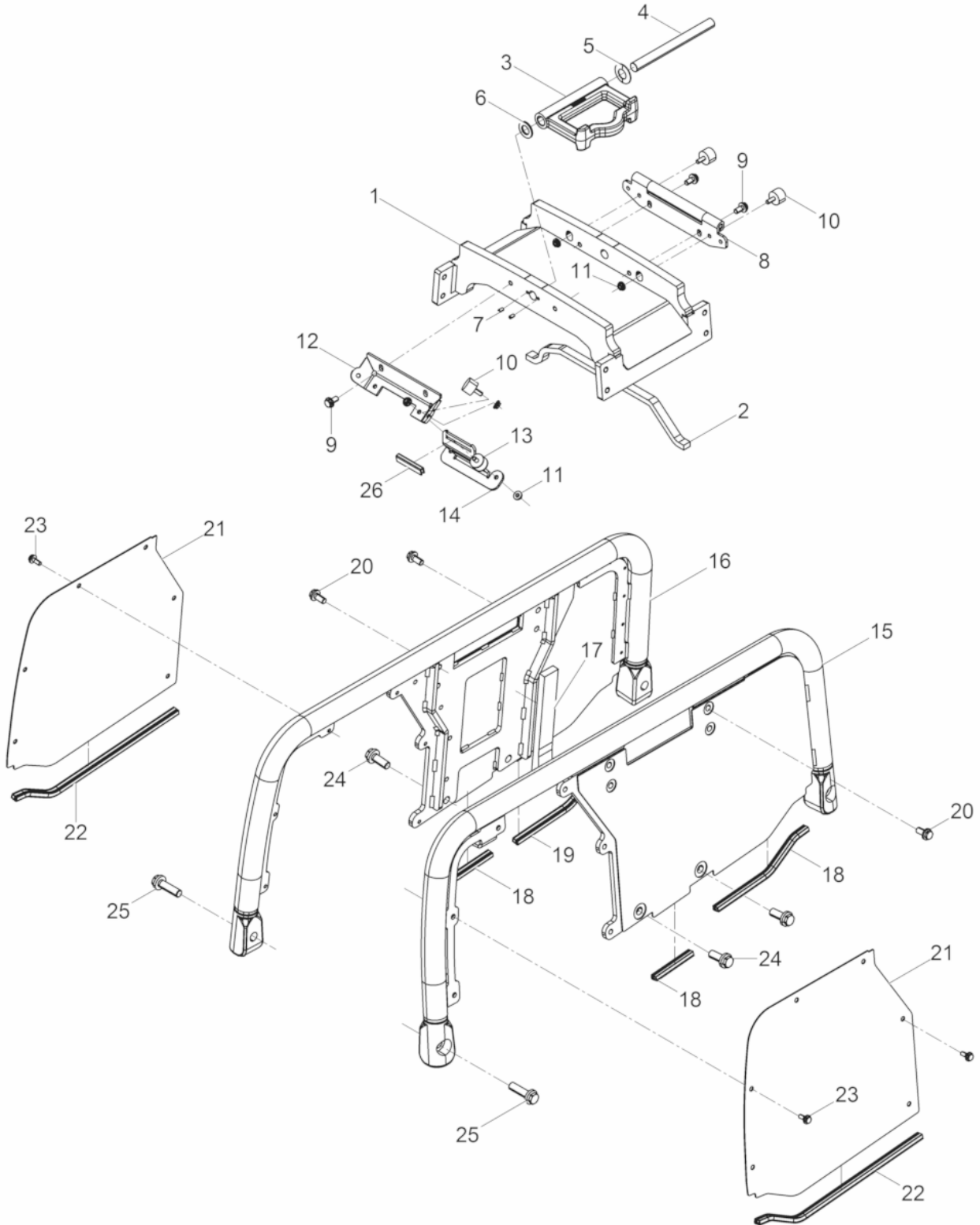

DPU110Lec870

Protective frame cpl. DPU110
Schutzrahmen kpl. DPU110
Armazón de protección cpl. DPU110
Cadre protection cpl. DPU110

Ref. Pos.	Part No. Artikel Nr.	Qty. St.	Description Beschreibung	Descripción Description	Measurement./Abm.	Norm
					Torque/Drehm.	Sealant Schmierstoff
26	5100025691	1	handle profile Griffprofil	perfil mango profil de la poignée		

Bonnet front cpl. DPU110
Haube vorne kpl. DPU110
Cubierta delantero cpl. DPU110
Capot avant cpl. DPU110

DPU110Lec870

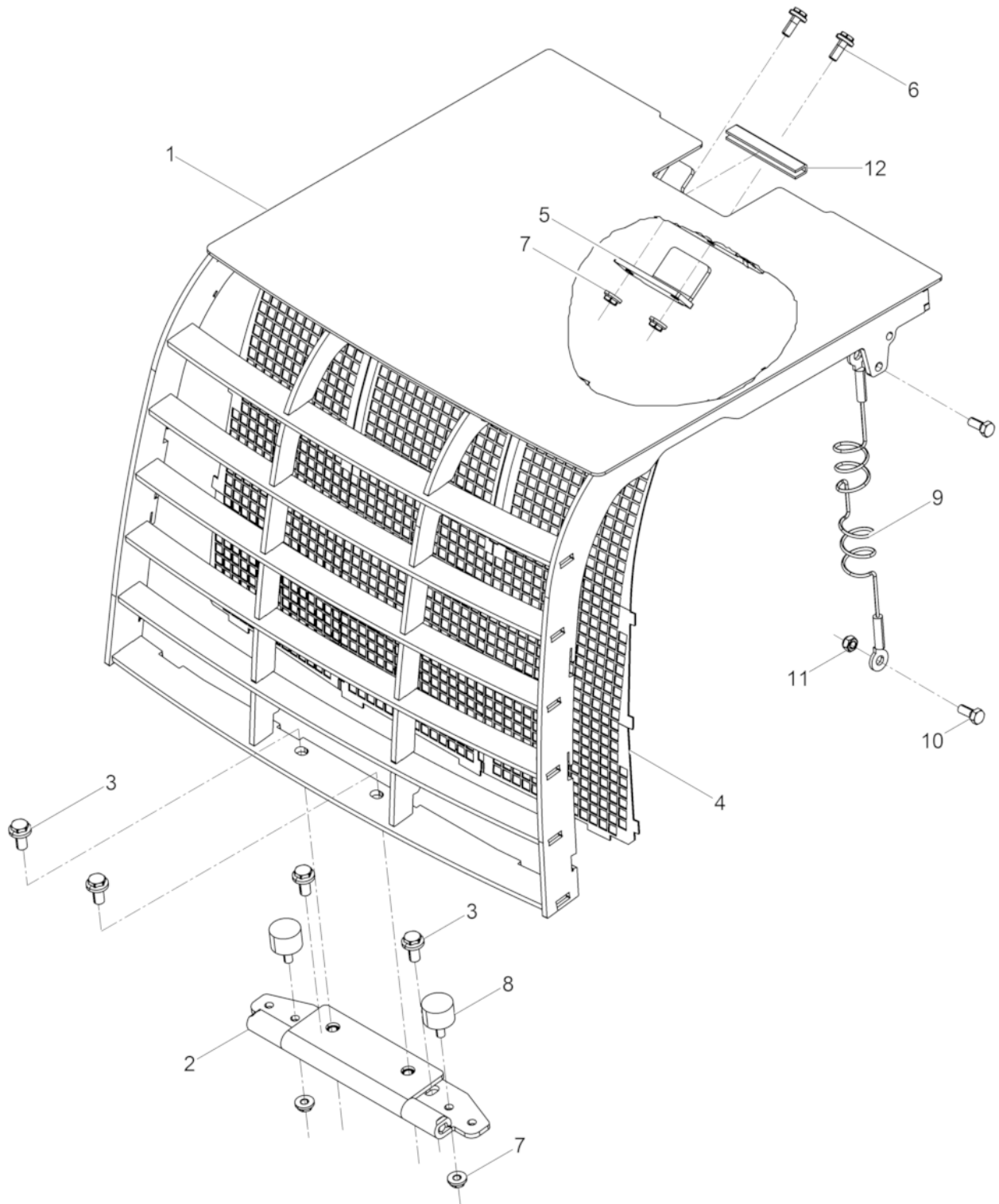

Ref. Pos.	Part No. Artikel Nr.	Qty. St.	Description Beschreibung	Descripción Description	Measurem./Abm.	Norm
					Torque/Drehm.	Sealant Schmierstoff
1	5100010437	1	Bonnet Haube	Cubierta Capot		
2	5100016051	1	Hinge Scharnier	Bisagra Charnière		
3	0210112	4	corrugated-head screw Sicherungsschraube	Tornillo Vis	85Nm/63ft.lbs	
4	5100010930	1	Screen grid front (DPU100) Schutzgitter vorne (DPU100)	Rejilla de protección delantero (DPU100) Grille de protection avant		
4	5100018899	1	Screen grid front (DPU100r) Schutzgitter vorne (DPU100r)	Rejilla de protección delantero (DPU100r) Grille de protection avant		
5	5100010577	1	Locking tab front Verriegelungslasche vorne	Lengüeta de bloqueo delantero Languette de verrouillage		
6	5100018058	2	corrugated-head screw Sicherungsschraube	tornillo de seguridad vis de sécurité		
7	5100017158	4	Locknut Sicherungsmutter	Contratuerca Contre-écrou	30Nm/22ft.lbs	
8	5100024474	2	Shockmount Anschlagpuffer	Amortiguador Silentbloc		
9	0154402	1	Cable Kabel	Cable Câble		
10	0012362	2	Hexagonal head cap screw Sechskantschraube	Tornillo hexagonal Vis à tête hexagonale	25Nm/18ft.lbs	
11	0033356	2	Hexagon nut Sechskantmutter	Tuerca hexagonal Écrou hexagonal		
12	5100024476	1	Edge protection Kantenschutz	Protección de cantos Protege arete	90Nm/66ft.lbs	

Bonnet rear cpl. DPU110
Haube hinten kpl. DPU110
Cubierta atrás cpl. DPU110
Capot arrière cpl. DPU110

DPU110Lec870

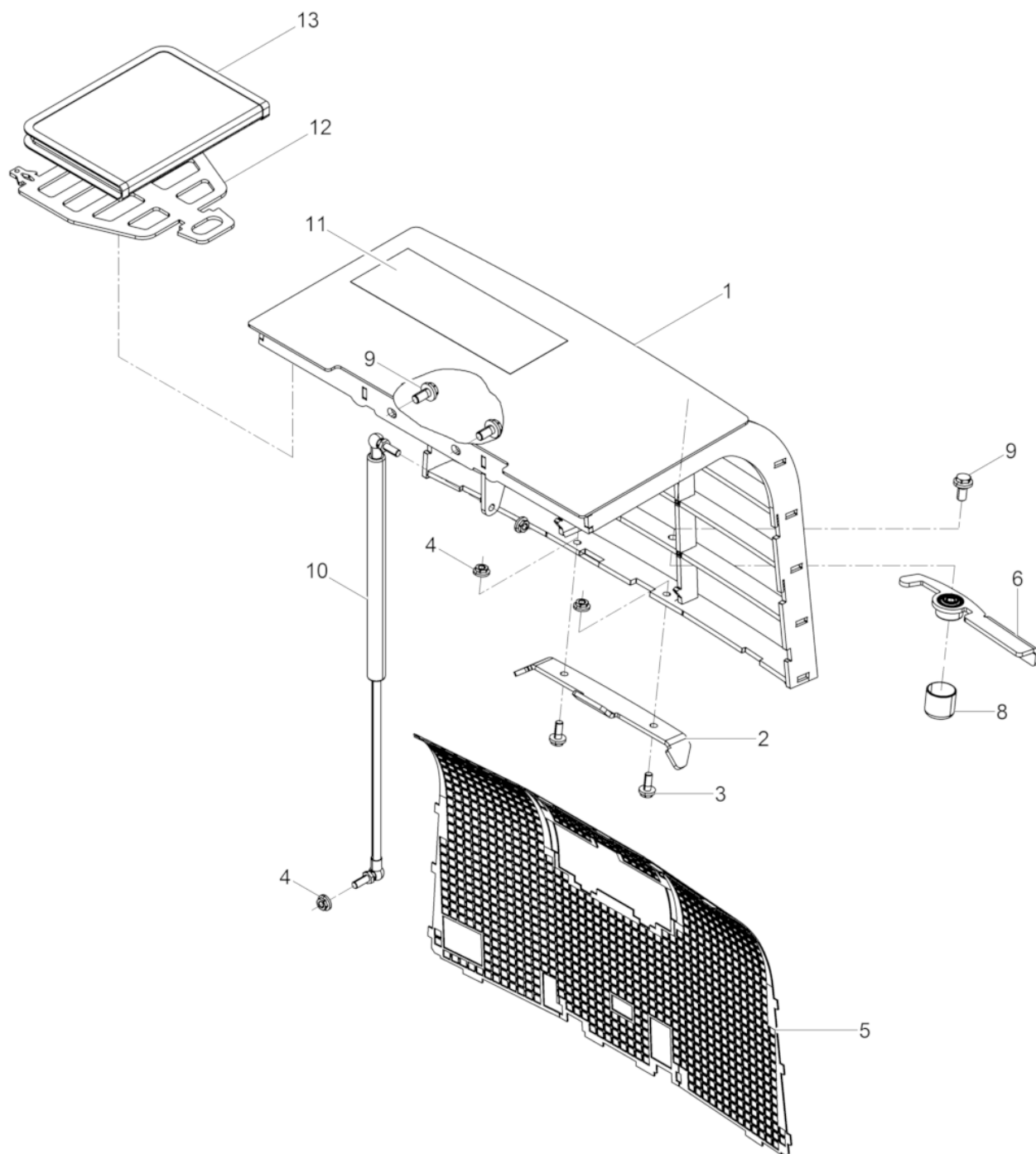

Ref. Pos.	Part No. Artikel Nr.	Qty. St.	Description Beschreibung	Descripción Description	Measurem./Abm.	Norm
					Torque/Drehm.	Sealant Schmierstoff
1	5100010436	1	Bonnet Haube	Cubierta Capot		
2	5100010578	1	Locking tab rear Verriegelungsglasche hinten	Lengüeta de bloqueo atrás Languette de verrouillage		
3	5100018058	2	corrugated-head screw Sicherungsschraube	tornillo de seguridad vis de sécurité		
4	5100017158	4	Locknut Sicherungsmutter	Contratuerca Contre-écrou	30Nm/22ft.lbs	
5	5100010932	1	Screen grid rear (DPU100) Schutzgitter hinten (DPU100)	Rejilla de protección atrás (DPU100) Grille de protection arrière		
5	5100018923	1	Screen grid rear (DPU100r) Schutzgitter hinten (DPU100r)	Rejilla de protección atrás (DPU100r) Grille de protection arrière		
5	5100018922	1	Screen grid rear (DPU100r,c) Schutzgitter hinten (DPU100r,c)	Rejilla de protección atrás (DPU100r,c) Grille de protection arrière		
5	5100018921	1	Screen grid rear (DPU100) Schutzgitter hinten (DPU100)	Rejilla de protección atrás (DPU100) Grille de protection arrière		
6	5100011262	1	Lever cpl. Hebel kpl.	Palanca cpl. Lever cpl.		
8	0068355	1	Protective cap Schutzkappe	Capa de protección Chape de protection		
9	0210112	3	corrugated-head screw Sicherungsschraube	Tornillo Vis	85Nm/63ft.lbs	
10	5100005810	1	Compr. spring Gasdruckfeder	Resorte de compresión Ressorte de pression		
11	5100017956	1	protection foil Schutzfolie	Hoja de protección Clinquant protection		
12	5100024201	1	cloth Lappen	Trapo languette		
13	5100025231	1	portfolio Mappe	carpeta portefeuille		

center pole cpl. DPU110
Deichsel kpl. DPU110
Barra de mando cpl. DPU110
Timon cpl. DPU110

DPU110Lec870

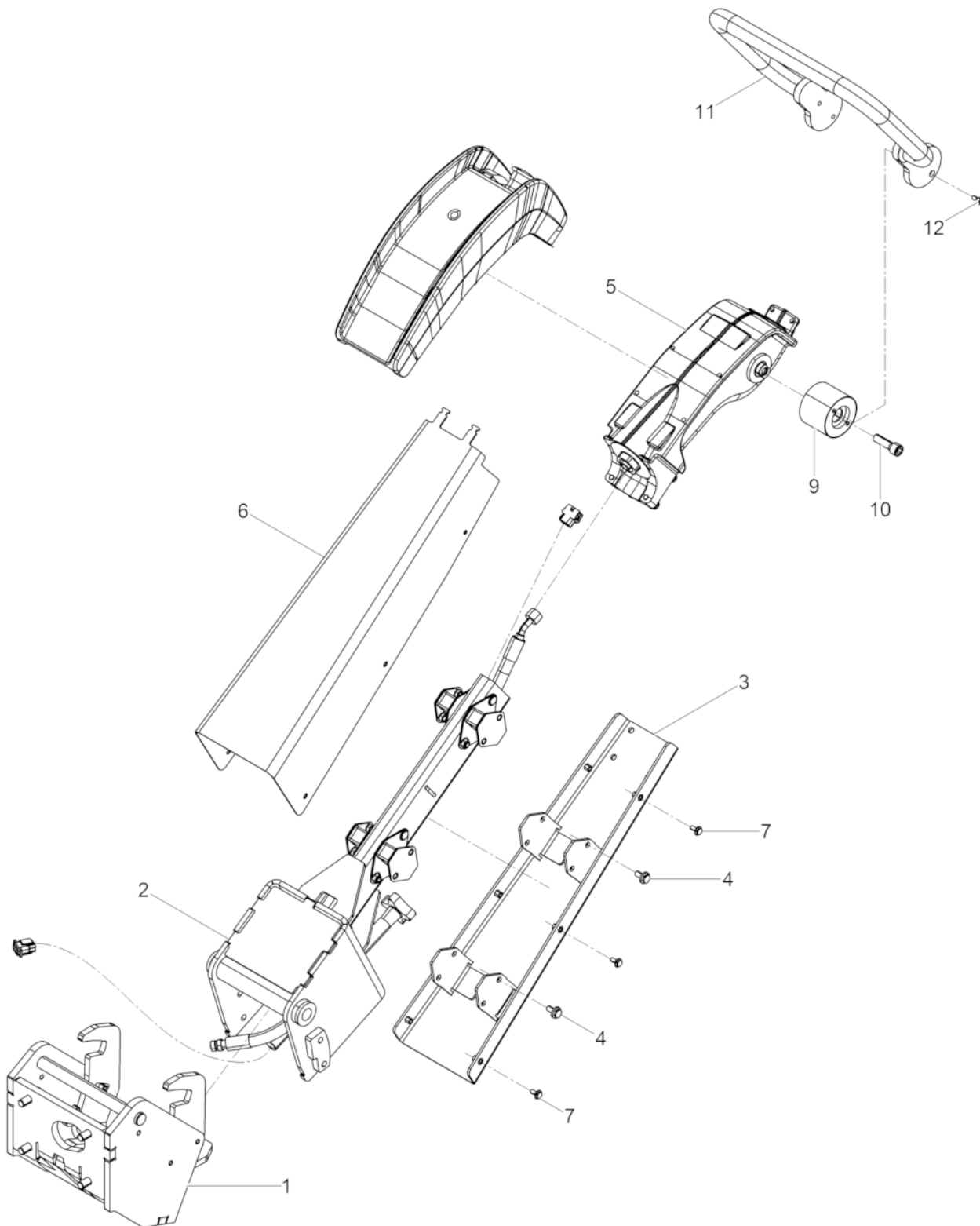

Ref. Pos.	Part No. Artikel Nr.	Qty. St.	Description Beschreibung	Descripción Description	Measurem./Abm.	Norm
					Torque/Drehm.	Sealant Schmierstoff
1	5100018077	1	Support cpl. Deichselbock kpl.	Caballote de apoyo cpl. Support cpl.		
2	5100018079	1	Center pole lower Part cpl. Deichselunterteil kpl.	Barra de mando parte inferior Timon partie inferieure cpl.		
3	5100009640	1	center pole base cpl. Deichselunterteil kpl.	Barra de mando parte inferior Timon partie inferieure cpl.		
4	0211795	8	corrugated-head screw Sicherheitsschraube	Tornillo Vis	42Nm/31ft.lbs	
5	5100018078	1	Center Pole Head cpl. Deichselkopf kpl.	Cabezal de mando cpl. Tête de timon cpl.		
6	5100005601	1	Covering Abdeckung	Cubierta Couverture		
7	0210194	6	corrugated-head screw Sicherheitsschraube	Tornillo Vis	19Nm/14ft.lbs	
9	0215035	2	Shockmount Gummi-Metall-Puffer	Tope caucho-metal Tampon metallique oscillant		
10	0011527	2	Cheese head screw Zylinderschraube	Tornillo cilíndrico Vis à tête cylindrique	86Nm/63ft.lbs	
11	5100005124	1	Clamp Bügel	Abrazadera Attache		
12	0011554	4	Cheese head screw Zylinderschraube	Tornillo cilíndrico Vis à tête cylindrique	10Nm/7ft.lbs	
13	0047388	1	Cable yarn Kabelbinder	Fijación de cables Attache de câble		
14	0038489	5	Tie cable Kabelbinder	Fijación Attache		

Support cpl.
Deichselbock kpl.
Caballete de apoyo cpl.
Support cpl.

DPU110Lec870

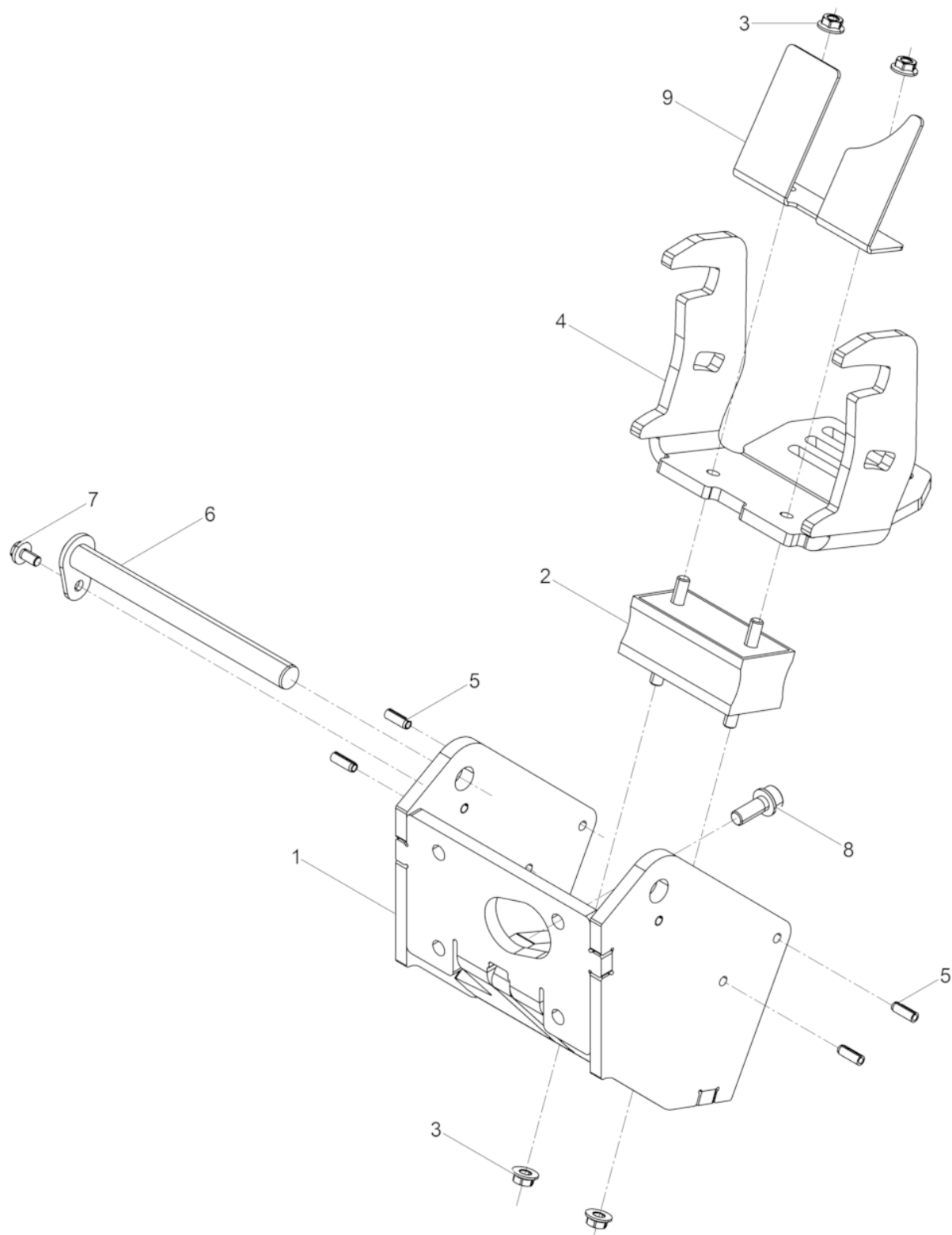

Ref. Pos.	Part No. Artikel Nr.	Qty. St.	Description Beschreibung	Descripción Description	Measurement/Abm.	Norm
					Torque/Drehm.	Sealant Schmierstoff
1	5100009748	1	Tow bar fixing Deichselbefestigung	Fijación de barra Porte-timon		
2	5100009740	1	Shockmount Gummipuffer	Tope caucho-metal Tampon oscillant		
3	0216640	4	Locknut Sicherungsmutter	Contratuerca Contre-écrou	60Nm/44ft.lbs	
4	5100005619	1	Lever Hebel	Palanca Levier		
5	5100018086	4	Roll pin Spannstift	Pasador Goupille de tension		
6	5100005617	1	Bolt Bolzen	Perno Boulon		
7	0211795	1	corrugated-head screw Sicherungsschraube	Tornillo Vis	42Nm/31ft.lbs	
8	5100010273	4	corrugated-head screw Sicherungsschraube	Tornillo Vis	150Nm/111ft.lbs	
9	5100022612	1	Guard plate Schutzblech	Chapa protectora Tôle de protection		

center pole base cpl.
Deichselunterteil kpl.

DPU110Lec870

Barra de mando parte inferior cpl.
Timon partie inferieure cpl.

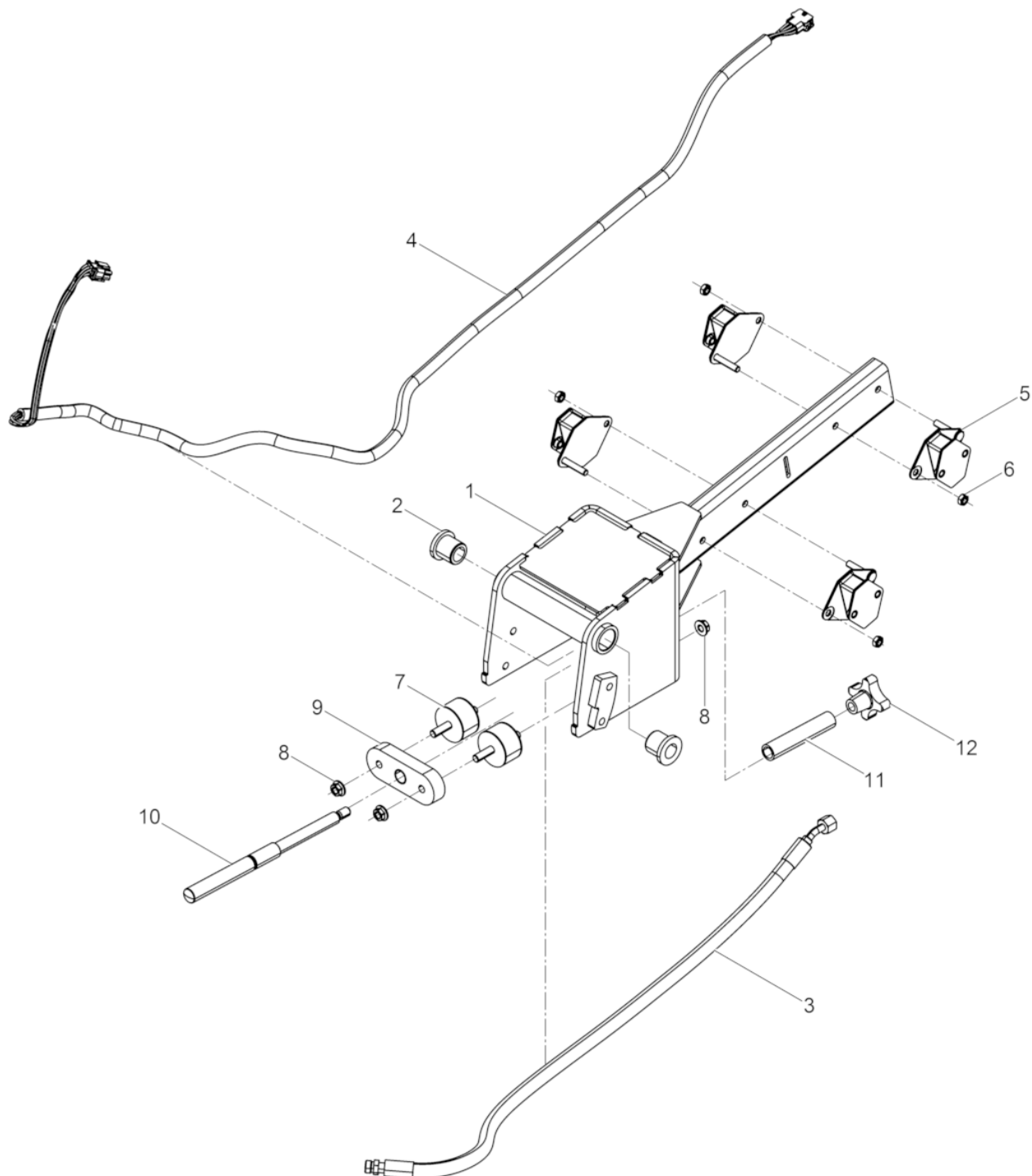

Ref. Pos.	Part No. Artikel Nr.	Qty. St.	Description Beschreibung	Descripción Description	Measurement/Abm.	Norm
					Torque/Drehm.	Sealant Schmierstoff
1	5100005592	1	Center pole base Deichselunterteil	Barra de mando inferior Timon bas		
2	5000220440	2	Bush Buchse	Buje Boîte		
3	5100010132	1	Hydraulic hose Hydraulikschlauch	Manguera hidráulica Tuyau hydraulique	15Nm/11ft.lbs	
4	5100005690	1	Wire harness center pole Kabelbaum Deichsel	Mazo de cables Barra de mando Harnais de câbles Timon		
5	5100010497	4	Shockmount Gummipuffer	Tope caucho-metal Tampon oscillant		
6	0010882	4	Hexagon nut Sechskantmutter	Tuerca hexagonal Écrou hexagonal		
7	5100017155	2	Shockmount Gummi-Metall-Puffer	Tope caucho-metal Tampon metallique oscillant		
8	0216640	4	Locknut Sicherungsmutter	Contratuerca Contre-écrou	60Nm/44ft.lbs	
9	5100005631	1	Bumper support Pufferaufnahme	Soporte de tope Fixation du tampon		
10	5100005622	1	Spindle Spindel	Husillo Pivot		
11	5100005623	1	Pipe Rohr	Tubo Tube		
12	5100005496	1	Star-handle Kreuzgriff	Empuñadura Poignée étoile		

Center Pole Head cpl. DPU110
Deichselkopf kpl. DPU110
Cabezal de Barra cpl. DPU110
Tête de Timon cpl. DPU110

DPU110Lec870

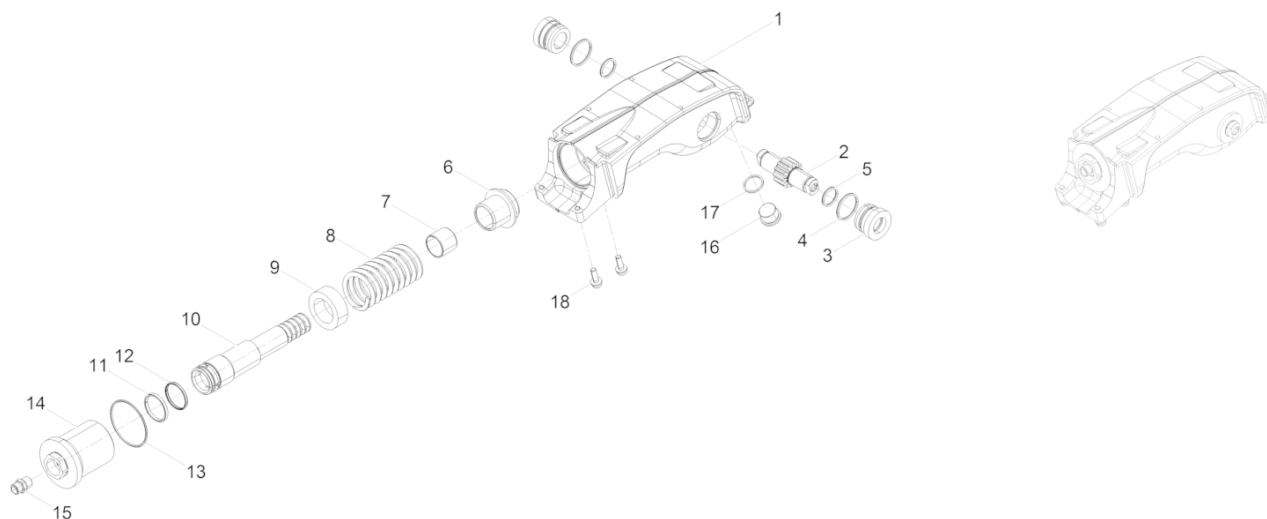

Ref. Pos.	Part No. Artikel Nr.	Qty. St.	Description Beschreibung	Descripción Description	Measurem./Abm.	Norm
					Torque/Drehm.	Sealant Schmierstoff
1	5100005148	1	Center pole head Deichselkopf	Cabezal de barra Tête de timon		
2	0069726	1	Long face pinion Zahnradwelle	Eje de rueda dentada Arbre formant pignon		
3	0125926	2	Spacer Distanzstück	Pieza distanciadora Pièce d'écartement		
4	0068752	2	O-ring O-Ring	Anillo-O Bague-O		
5	0018194	2	O-ring O-Ring	Anillo-O Bague-O		
6	5100005285	1	Bearing flange Lagerflansch	Brida-rodamiento Collerette-roulement		
7	5100005685	1	Slide bush Gleitbuchse	Buje deslizante Boîte de glissement		
8	5100017017	1	Compression spring Druckfeder	Resorte de compresión Ressort de pression		
9	5100005563	1	Collar Hülse	Collar Douille		
10	5100005287	1	Piston rod Kolbenstange	Biela de pistón Tige de piston		
11	5100005683	1	Ring Ring	Anillo Anneau		
12	5100005688	1	Gasket Dichtring	Anillo de junta Bague d'étanchéité		
13	5100005689	1	O-Ring O-Ring	Anillo-O Bague-O		
14	5100005284	1	Hydraulic cylinder Hydraulikzylinder	Cilindro Cilindre	120Nm/89ft.lbs	
15	0069225	1	Screwed socket Einschraubstutzen	Empalme roscado Manchon visse	60Nm/44ft.lbs	
16	5100019617	1	Oil plug Verschlußschraube	Tapón roscado Bouchon	50Nm/37ft.lbs	
17	0032006	1	Gasket Dichtring	Anillo de junta Bague d'étanchéité		
18	0129420	4	Socket head cap screw Zylindersicherungsschraube	Tornillo de seguridad Poignée supplémentaire	45Nm/33ft.lbs	

Bonnet cpl.
Haube kpl.
Cubierta cpl.
Capot cpl.

DPU110Lec870

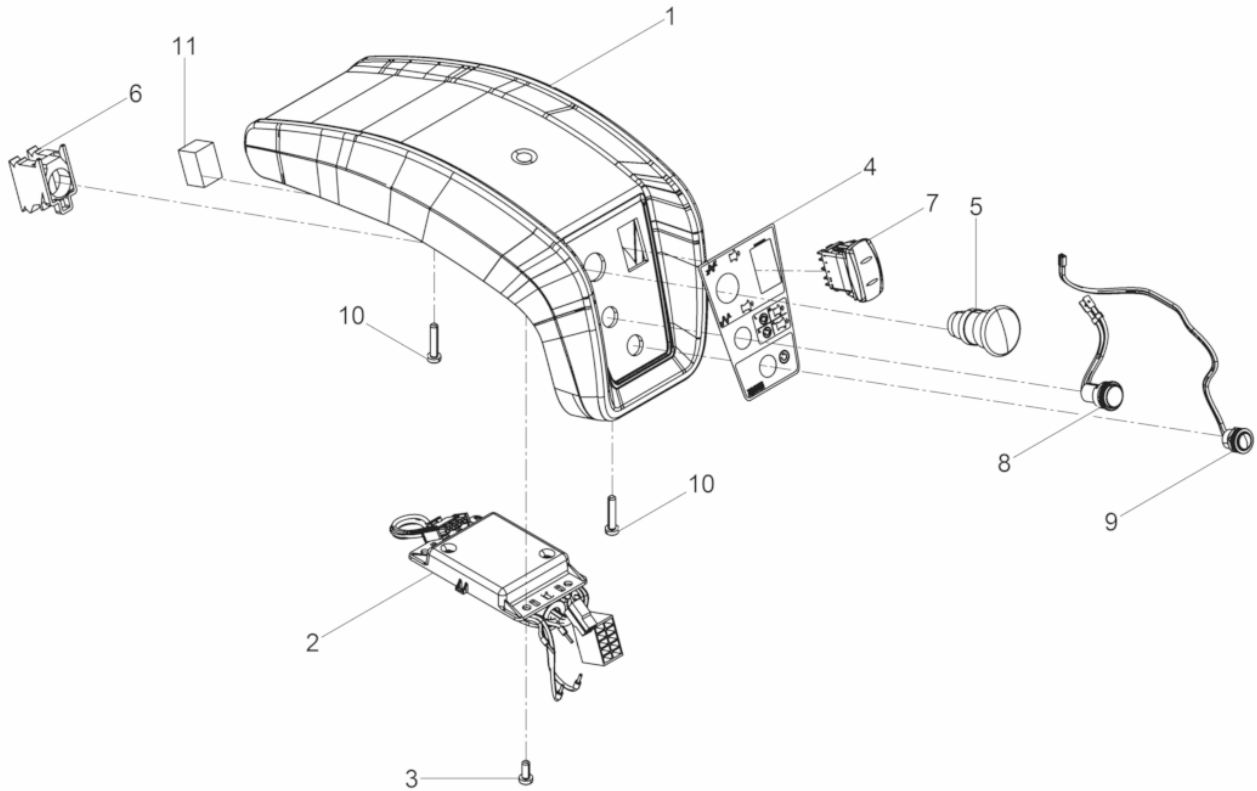

Ref. Pos.	Part No. Artikel Nr.	Qty. St.	Description Beschreibung	Descripción Description	Measurement./Abm.	Norm
					Torque/Drehm.	Sealant Schmierstoff
1	5100024486	1	Bonnet (gray) Haube (grau)	Cubierta (gris) Capot (gris)		
1	5100009242	1	Bonnet Haube	Cubierta Capot		
2	5100034271	1	Steering part Steuerteil	Elemento de mando Régulateur		
3	0108371	4	Oval head screw Linsenkopfschraube	Tornillo gota de sebo Vis noyée lentiforme		
4	5100010274	1	Label Aufkleber	Calcomania Autocollant		
5	5100010113	1	Button switch Druckknopfschalter	Interruptor a pulsador Interrupteur de pression		
6	5100016488	1	Auxiliary owner block Hilfsschalterblock	Bloque auxiliar del dueño Bloc auxiliaire de propriétaire		
7	5100034270	1	rockerswitch Wipptaster	Interruptor Interrupteur		
8	5100010111	1	LED LED Leuchte	Diodo Diode luminescente		
9	5100010070	1	Botton switch Drucktaster	Interruptor a pulsador Interrupteur de pression		
10	0108370	6	Oval head screw Linsenkopfschraube	Tornillo gota de sebo Vis noyée lentiforme		
11	5100034272	1	Insulating cushion Kissen	Almohadilla Coussin		

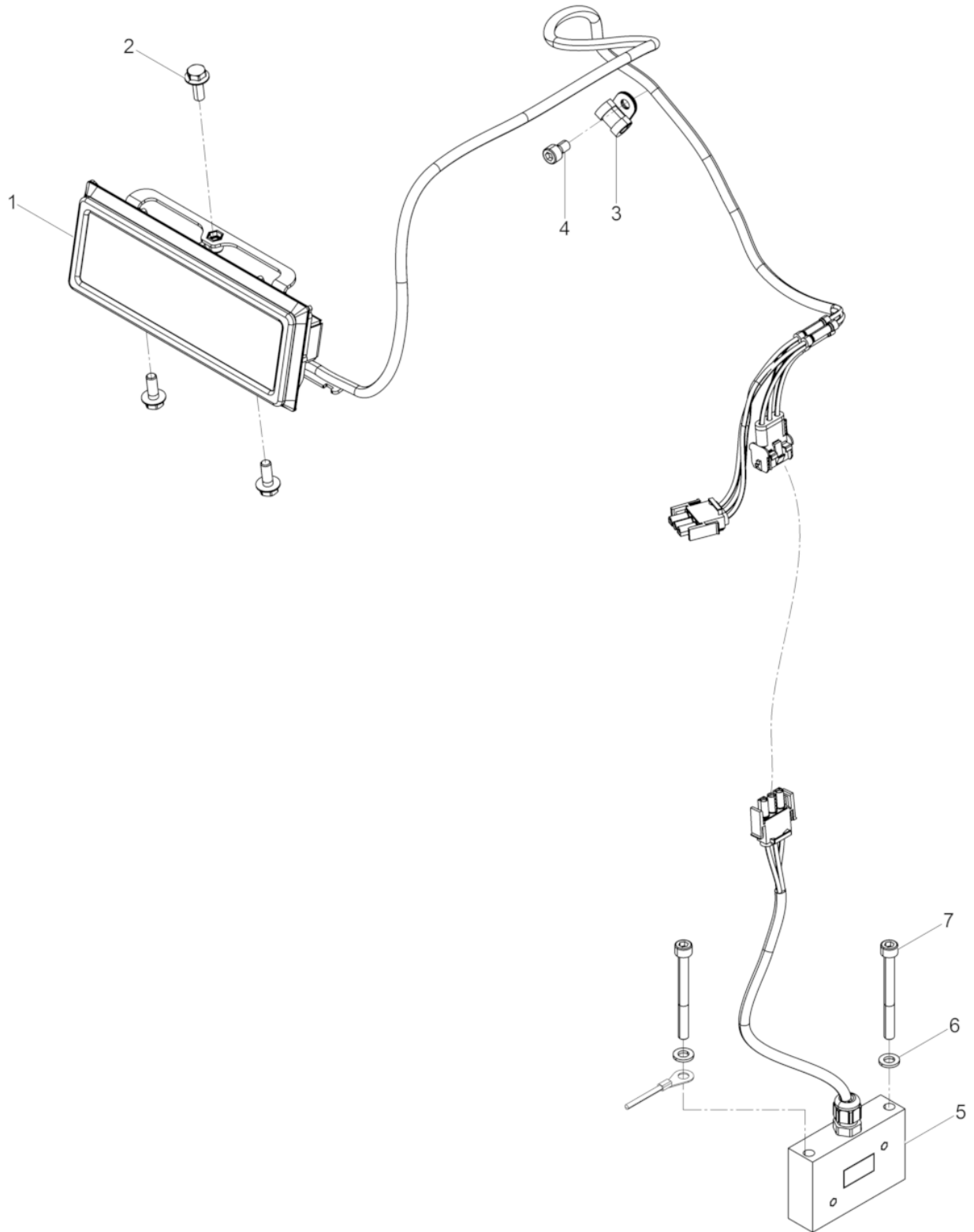

Ref. Pos.	Part No. Artikel Nr.	Qty. St.	Description Beschreibung	Descripción Description	Measurement./Abm.	Norm
					Torque/Drehm.	Sealant Schmierstoff
1	5100010020	1	Display cpl. Anzeigeeinheit kpl.	consola de visualización cpl. console de visualisation cpl.		
2	5100016654	3	corrugated-head screw Sicherungsschraube	Tornillo Vis	M 6x 16	
3	0212143	1	Clamp Rohrschelle	Abrazadera Agrafe	RSGU 1.6/15	
4	0011555	1	Cheese head screw Zylinderschraube	Tornillo cilíndrico Vis à tête cylindrique	M6 x 10 10Nm/7ft.lbs	ISO4762
5	5100010005	1	Sensor cpl. Sensor kpl.	Sensor cpl. Capteur cpl.		
6	0010624	1	Flat washer Scheibe	Arandela Rondelle		
7	0037071	2	Cheese head screw Zylinderschraube	Tornillo cilíndrico Vis à tête cylindrique	10Nm/7ft.lbs	

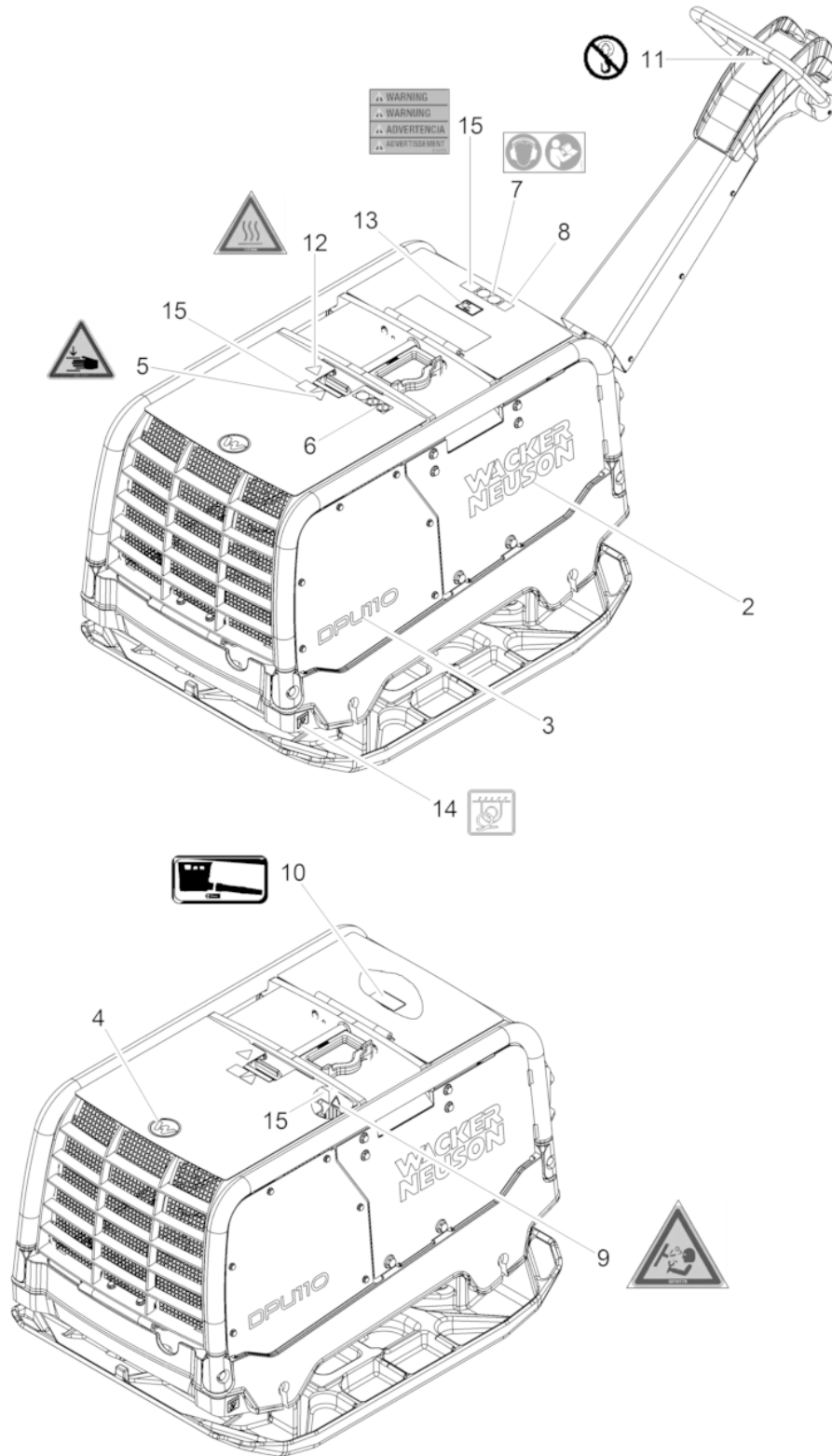

Ref. Pos.	Part No. Artikel Nr.	Qty. St.	Description Beschreibung	Descripción Description	Measurem./Abm.	Norm
					Torque/Drehm.	Sealant Schmierstoff
2	0222103	2	Label logo Aufkleber Logo	Calcomania Insignia Autocollant Logo	80 mm	
3	5100024540	2	Type Label DPU90 Aufkleber Typ DPU90	Tipo etiqueta autoadhesiva DPU90 Aufkleber Typ DPU90		
3	5100017955	2	Type Label DPU80r Aufkleber-Typ DPU80r	Tipo etiqueta autoadhesiva 80r Autocollant de type DPU80r		
3	5100017954	2	Type Label DPU80 Aufkleber-Typ DPU80	Tipo etiqueta autoadhesiva 80 Autocollant de type DPU80		
3	5100017952	2	Type Label DPU110 Aufkleber-Typ DPU110	Tipo etiqueta autoadhesiva DPU110 Autocollant de type DPU110		
3	5100024541	2	Type Label DPU90r Aufkleber Typ DPU90r	Tipo etiqueta autoadhesiva DPU90r Autocollant de type DPU90r		
3	5100017953	2	Type Label DPU110r Aufkleber-Typ DPU110r	Tipo etiqueta autoadhesiva DPU110r Autocollant de type DPU110r		
4	0222086	1	Label Symbol Aufkleber Symbol	Calcomania Símbolo Autocollant Symbole		
5	0207747	1	Danger label Aufkleber Quetschgefahr	Calcomania de peligro Autocollant de danger		
6	0216633	1	Instruction Label Aufkleber-Hinweis	Calcomanía-Indicación Autocollant avec Indication		
7	0219175	1	Labels Aufkleber	Calcomanias Autocollants		
8	0064925	1	Decal-Sound Power Level Aufkleber-Schalleistungspegel	Etiqueta autoadhesiva-nivel de potencia acústica Autocollante-niveau sonore		
9	0219179	1	Labels Aufkleber	Calcomanias Autocollants		
10	0216635	1	Labels Aufkleber	Calcomanias Autocollants		
11	0220000	1	Instruction Label Aufkleber-Warnhinweis	Calcomanía-Indicación Autocollant avec Indication		
12	0219080	1	Labels Aufkleber	Calcomanias Autocollants		
13	5100011227	1	Label HAV 24h Aufkleber HAV 24h	Calcomania HAV 24h Autocollant HAV 24h		
14	1000184310	4	Label Aufkleber	Calcomania Autocollant		
15	0219176	3	Labels Aufkleber	Calcomanias Autocollants		
17	5100045462	1	Label Label	Label Label		



**WACKER
NEUSON**

**Engine DPU110
Motor DPU110
Motor DPU110
Moteur DPU110**

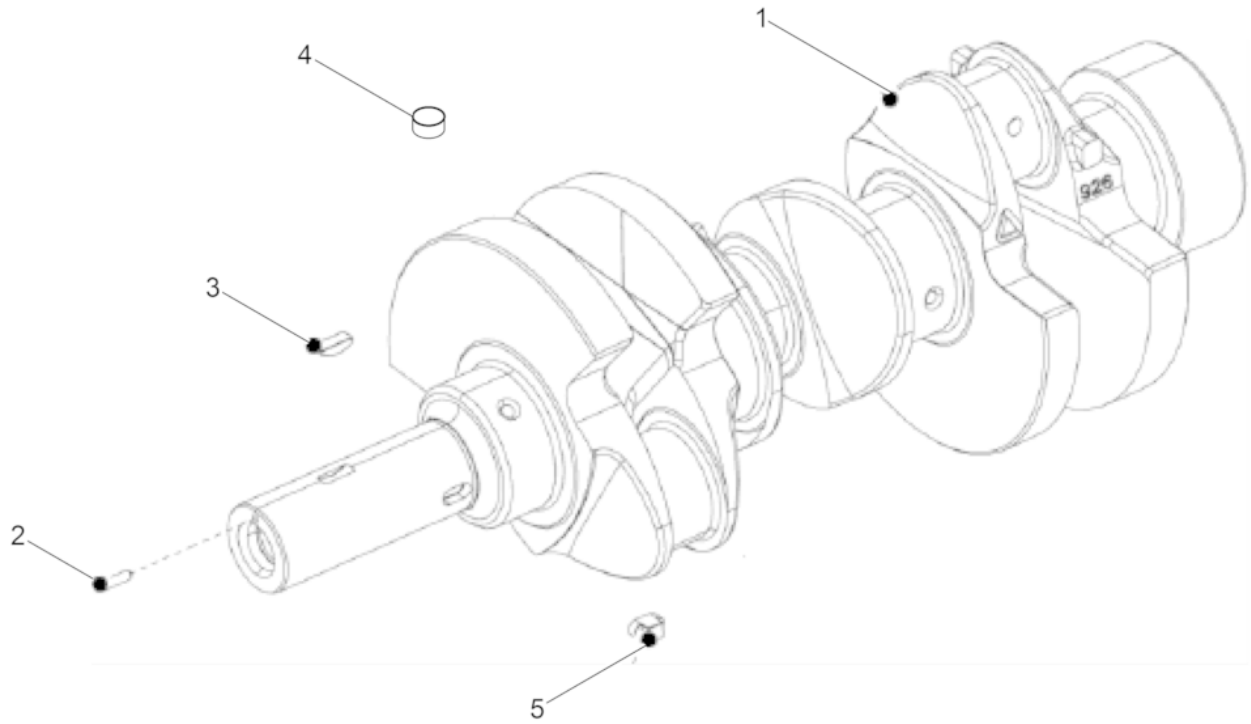

Ref. Pos.	Part No. Artikel Nr.	Qty. St.	Description Beschreibung	Descripción Description	Measurement./Abm.	Norm
					Torque/Drehm.	Sealant Schmierstoff
1	0160365	1	Crankshaft Kurbelwelle	Cigüeñal Vilebrequin		
2	0159357	1	Pin Stift	Espiga Goupille		
3	0159260	1	Woodruff key Woodruffkeil	Chaveta Woodruff Clavette Woodruff		
4	0159454	3	Plug (threaded) Schraubverschluß	Tapón roscado Bouchon		
5	0159261	1	Square key Passfeder	Chaveta Clavette		

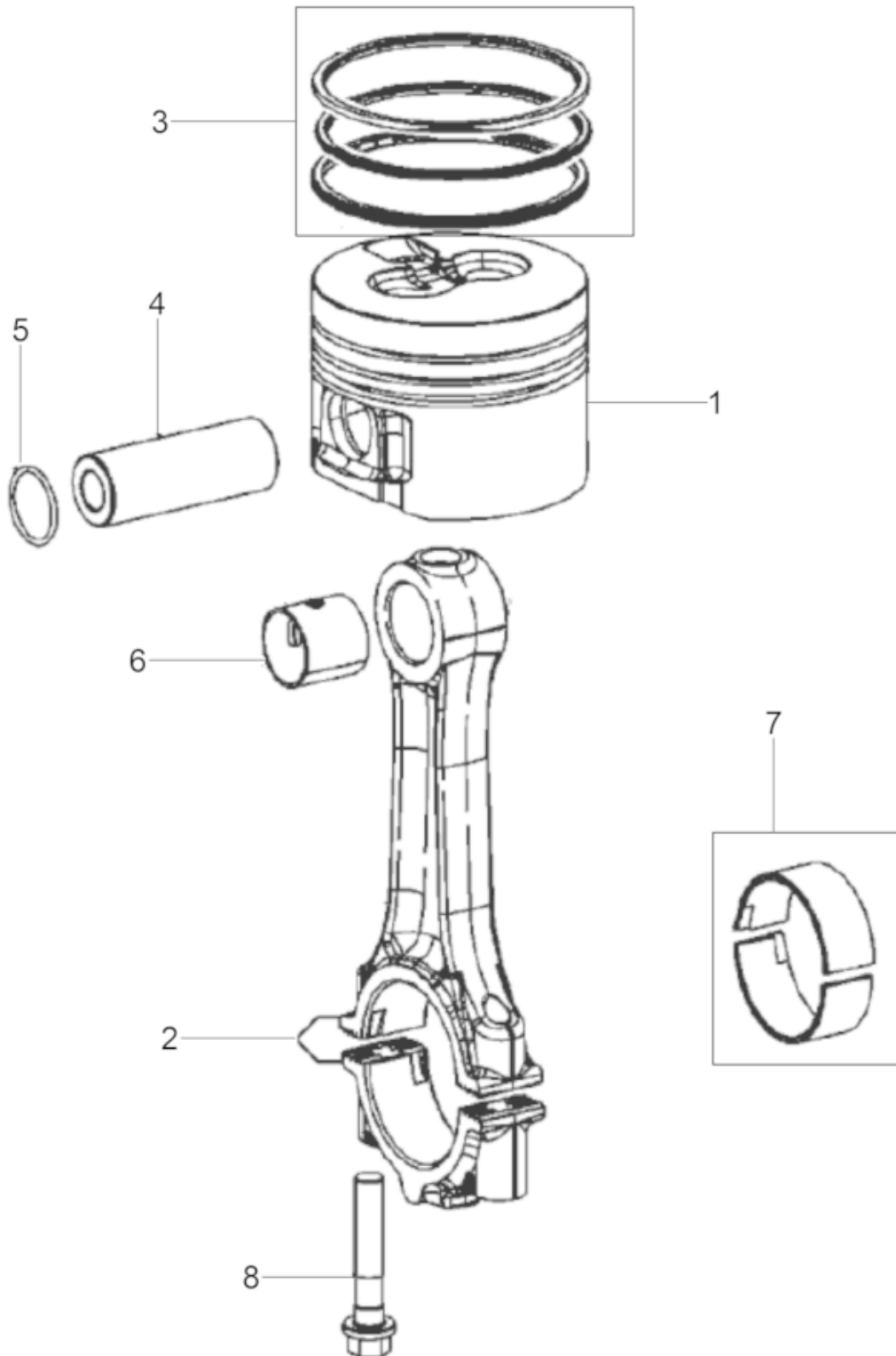

Ref. Pos.	Part No. Artikel Nr.	Qty. St.	Description Beschreibung	Descripción Description	Measurem./Abm.	Norm
					Torque/Drehm.	Sealant Schmierstoff
1	0160375	3	Set Of Piston Kolbensatz	Juego de Pistón Jeu de Piston		
1	0160376	3	Set Of Piston Kolbensatz	Juego de Pistón Jeu de Piston		
1	0160377	3	Set Of Piston Kolbensatz	Juego de Pistón Jeu de Piston		
2	0160367	3	Connecting rod Pleuel	Biela Bielle		
3	0160383	2	Piston Ring Set Kolbenringsatz	Juego de cubo levantador Jeu de moyeu de levage		
3	0160384	2	Kit-lift ring Ringsatz	Juego de cubo levantador Jeu de moyeu de levage		
3	0160385	2	Kit-lift ring Ringsatz	Juego de cubo levantador Jeu de moyeu de levage		
4	0215523	3	Piston pin Kolbenbolzen	Perno de pistón Axe de piston		
5	0215477	6	Retaining ring Sicherungsring	Anillo de retención Bague d'arrêt		
6	0160368	2	Bushing Buchse	Buje Douille		
7	0155689	2	Bearing Lagerschalen	Rodamiento Roulement		
7	0155690	2	Bearing Pleuellagerangen	Rodamiento Roulement		
7	0155691	2	Bearing Pleuellagerangen	Rodamiento Roulement		
8	0084175	4	Screw Schraube	Tornillo Vis		

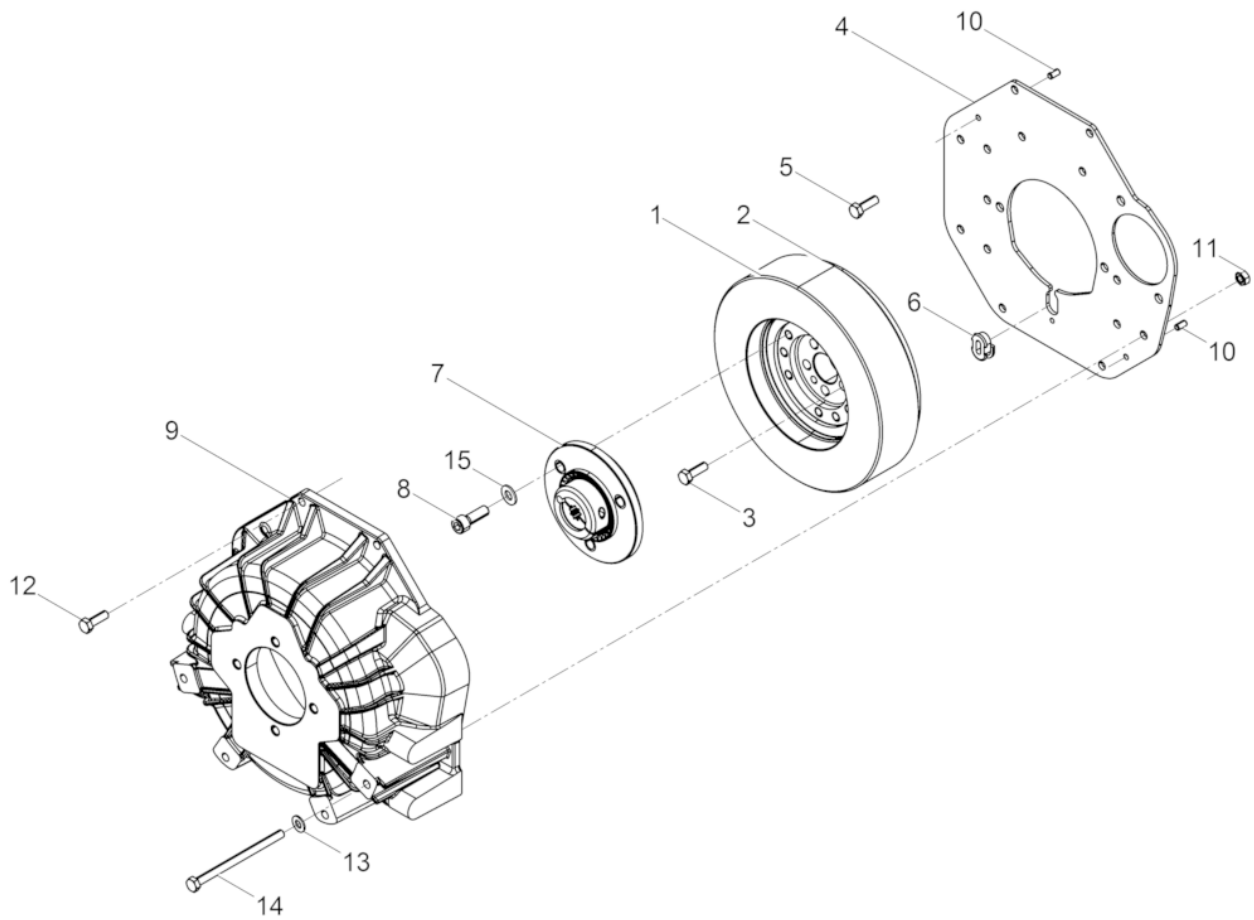

Ref. Pos.	Part No. Artikel Nr.	Qty. St.	Description Beschreibung	Descripción Description	Measurem./Abm.	Norm
					Torque/Drehm.	Sealant Schmierstoff
1	0215545	1	Flywheel Schwungrad	Volante Volant		
2	0155693	1	Gear crown Zahnkranz	Borde de engranaje Jante d'engrenage		
3	0160188	5	Bolt Bolzen	Perno Boulon		
4	0159326	1	Plate Platte	Placa Plaque		
5	0159254	9	Bolt Bolzen	Perno Boulon		
6	0215527	1	Plug Stopfen	Tapón Bouchon		
7	0211373	1	Coupling cpl. Kupplung kpl.	Embrague cpl. Embrayage cpl.		
8	0084164	3	Screw Schraube	Tornillo Vis		
9	0215567	1	Holder Halter	Soporte Attache		
10	0211370	2	Pin Stift	Espiga Goupille		
11	0082140	3	Nut Mutter	Tuerca Écrou		
12	0084123	3	Screw Schraube	Tornillo Vis		
13	0211371	4	Washer Scheibe	Disco Rondelle		
14	0211372	4	Screw Schraube	Tornillo Vis		
15	0160231	3	Washer Scheibe	Disco Rondelle		

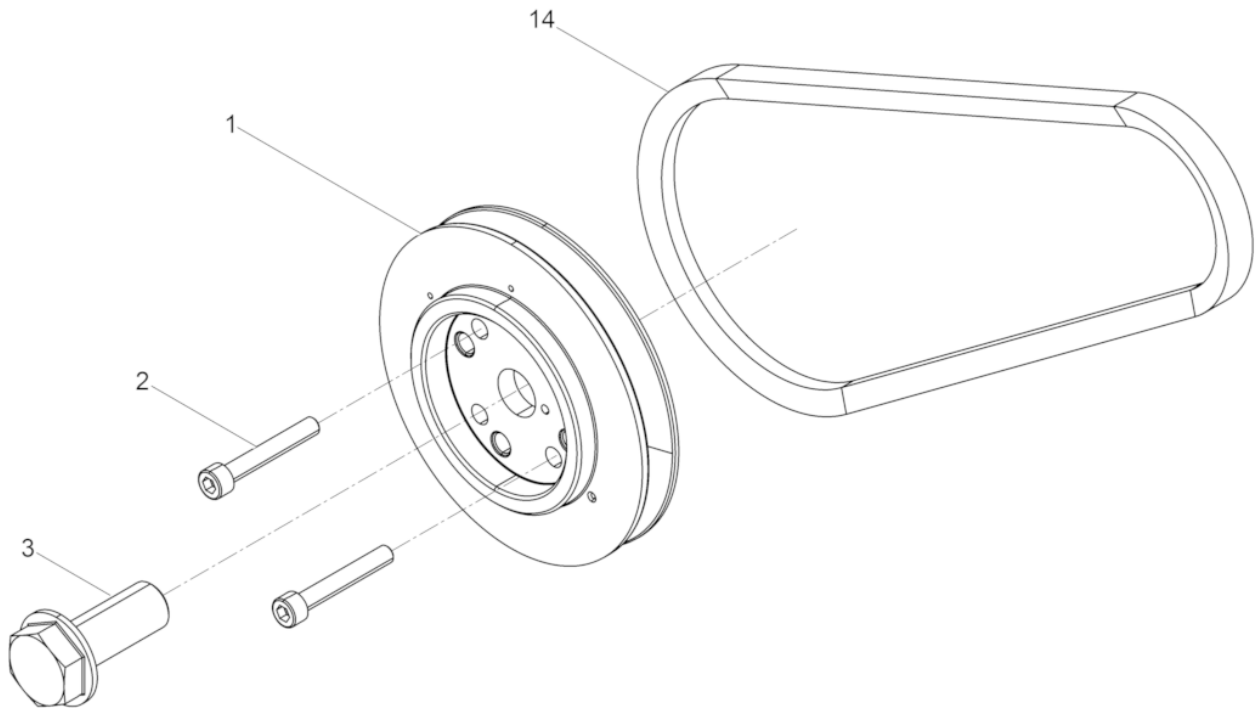

Ref. Pos.	Part No. Artikel Nr.	Qty. St.	Description Beschreibung	Descripción Description	Measurem./Abm.	Norm
					Torque/Drehm.	Sealant Schmierstoff
1	5100026267	1	V-belt pulley Riemenscheibe	Polea Poulie		
2	0159475	4	Screw Schraube	tornillo vis		
3	0126935	1	Bolt Bolzen	Perno Boulon		
14	0215485	1	Belt Zahnriemen	Correa Courroie		

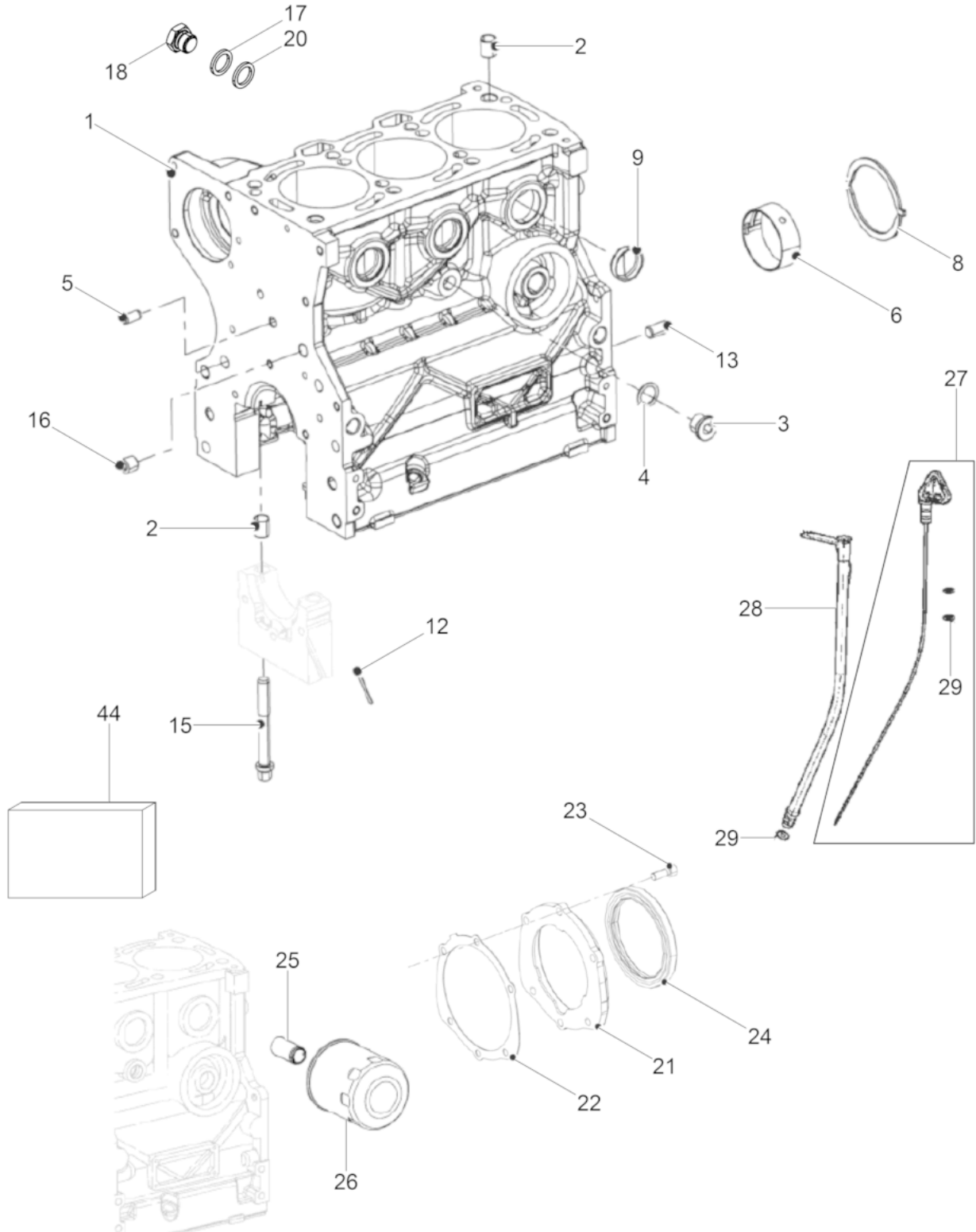

Ref. Pos.	Part No. Artikel Nr.	Qty. St.	Description Beschreibung	Descripción Description	Measurem./Abm.	Norm
					Torque/Drehm.	Sealant Schmierstoff
1	5100026422	1	Crankcase Kurbelgehäuse	Cárter Carter		
2	0159257	2	Sleeve Hülse	Collar Douille		
3	0206229	1	Screw Schraube	Tornillo Vis		
4	0082184	1	Ring seal Dichtring	Anillo sellador Rondelle à étancher		
5	0215522	1	Pin Stift	Espiga Goupille		
6	0155702	3	Bearing Lager	Cojinete Palier		
6	0155703	3	Bearing Lager	Cojinete Palier		
6	0155704	3	Bearing Lager	Cojinete Palier		
8	0159486	2	Washer Scheibe	Disco Rondelle		
8	0159487	2	Disc Scheibe	Disco Disque		
8	0159488	2	Disc Scheibe	Disco Disque		
9	0082335	4	Plug (threaded) Schraubverschluß	Tapón roscado Bouchon		
12	0159288	4	Gasket Dichtung	Junta Joint		
13	0159360	2	Dowel pin Paßstift	Espiga Cheville		
15	0159480	8	Screw Schraube	Tornillo Vis		
16	0159456	1	Plug Stopfen	Tapón Bouchon		
17	0159299	1	Washer Scheibe	Disco Rondelle		
18	0215530	1	Plug Stopfen	Enchufe Prise		
20	0082183	1	Ring seal Dichtring	Anillo sellador Rondelle à étancher		
21	0155700	1	Flange Flansch	Brida Collerette		
22	0217807	1	Gasket Dichtung	Junta de estanqueidad Garniture		
23	0159467	6	Cover Deckel	Cubierta Couvercle		
24	0155701	1	Rotary shaft seal Wellendichtring	Anillo de retén radial Bague d'étanchéité		
25	0159341	1	Fitting-oil filter Ölfilterverschraubung	Unión de filtro de aceite deaceite Raccord de filtre d'huile		
26	5100026398	1	Oil filter Ölfiltersatz	Filtro de aceite Filtre d'huile		

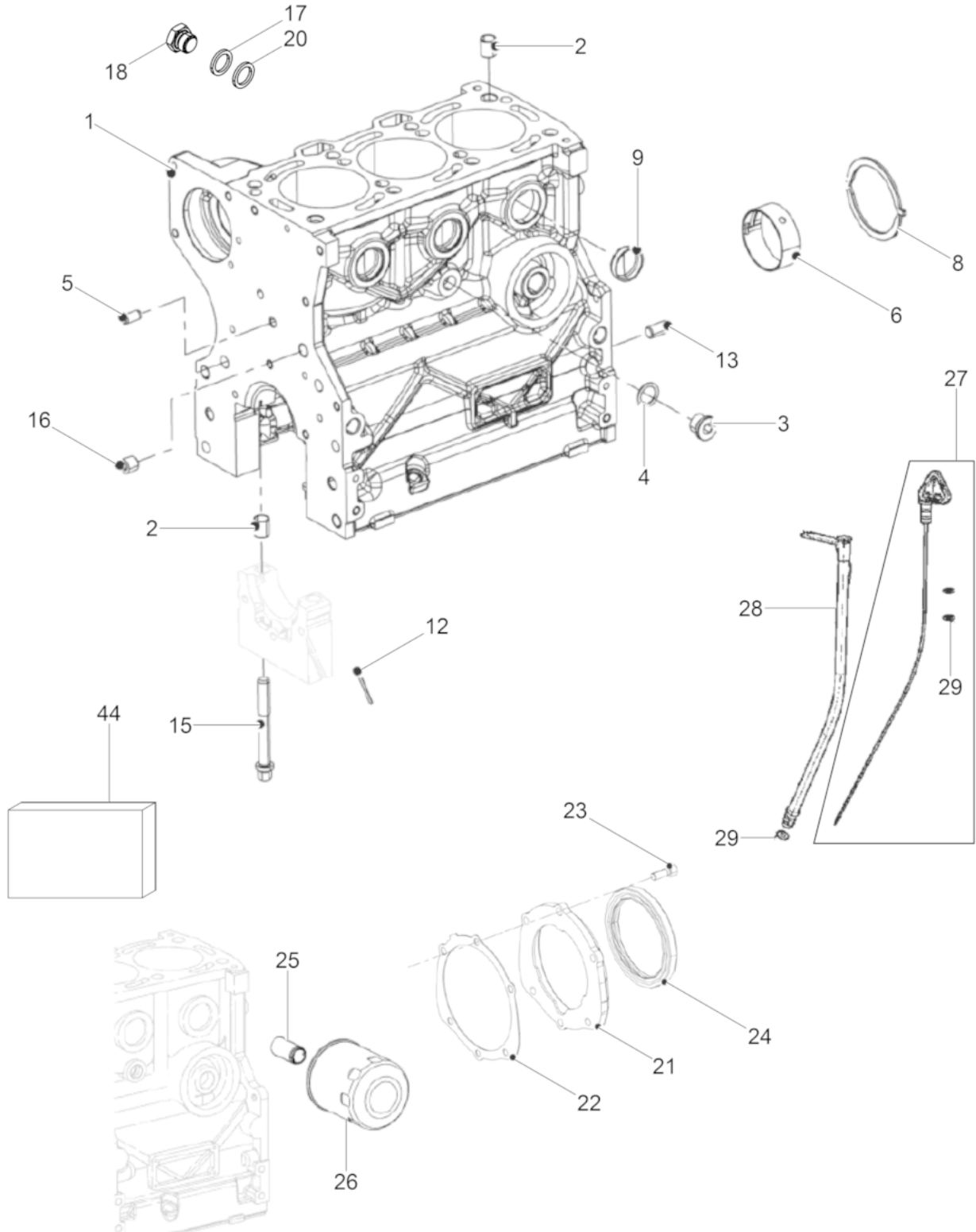

Ref. Pos.	Part No. Artikel Nr.	Qty. St.	Description Beschreibung	Descripción Description	Measurement./Abm.	Norm
					Torque/Drehm.	Sealant Schmierstoff
27	5100008859	1	Oil dip stick Ölmesstab	Varilla de sondear aceite Jauge de niveau d'huile		
28	0215533	1	Dipstick guard Schutz für Peilstab	Protector del indicador del nivel de aceite Protecteur pour réglette-jauge		
29	0063695	2	O-Ring O-Ring	Anillo-O Joint torique		
44	0159397	1	Crankcase Gasket Set Dichtungssatz, Kurbelgehäuse	Juego de juntas, cárter Jeu de joints, carter		

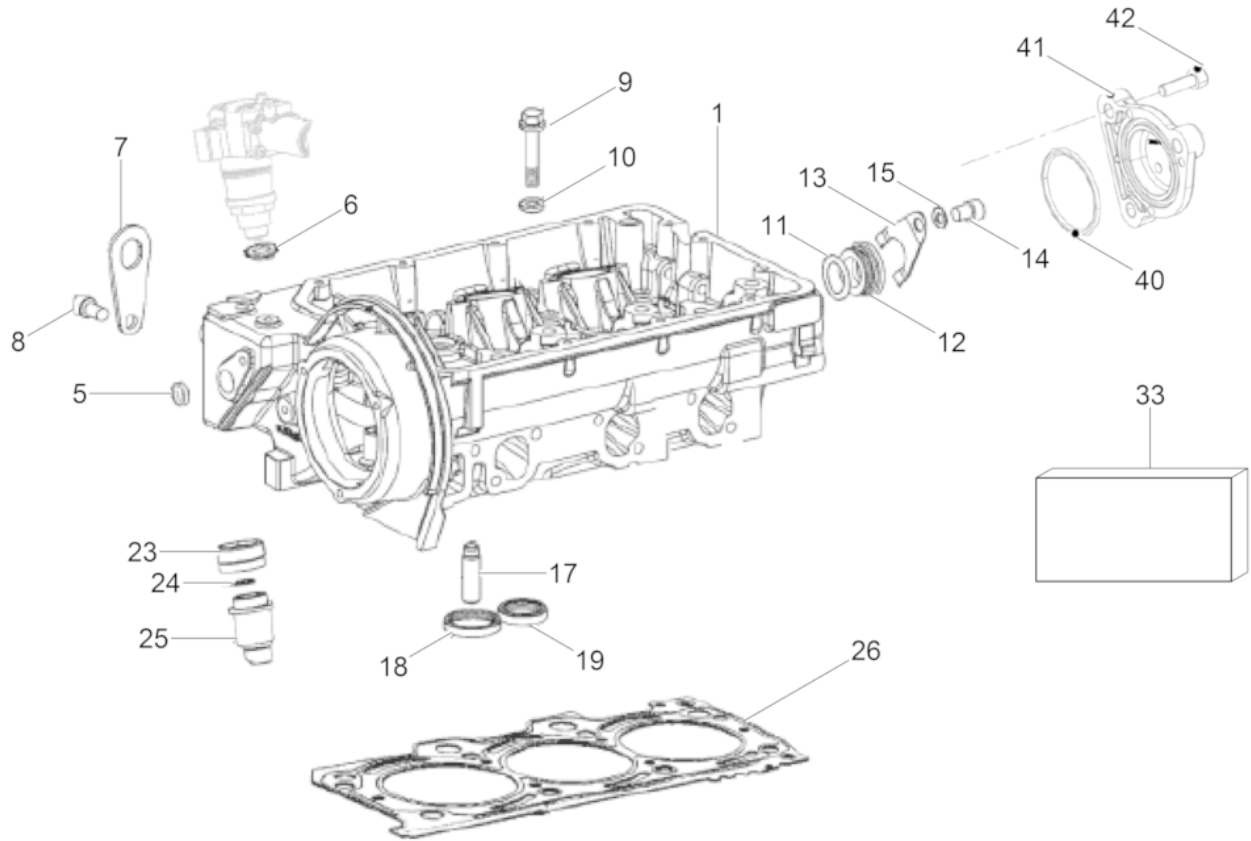

Ref. Pos.	Part No. Artikel Nr.	Qty. St.	Description Beschreibung	Descripción Description	Measurem./Abm.	Norm
					Torque/Drehm.	Sealant Schmierstoff
1	0160388	1	Cylinder head Zylinderkopf	Culata Culasse		
5	0159449	2	Plug Stopfen	Enchufe Prise		
6	0159318	3	Spark arrester Funkenfänger	Parachispas Pare-étincelles		
7	0215524	2	Lifting point Aufhängung	Punto para itar Suspension		
8	0084156	1	Screw Schraube	Tornillo Vis		
9	0217828	8	Flange screw Flanschschraube	Tornillo de brida Vis de bride		
10	0159350	8	Washer Scheibe	Arandela Rondelle		
11	0159231	1	O-ring O-ring	Anillo en forma de o Joint torique		
12	0159453	1	Plug Stopfen	Enchufe Prise		
13	0159311	1	Bracket Halter	Soporte Équerre		
14	0159254	1	Bolt Bolzen	Perno Boulon		
15	0082292	1	Washer Scheibe	Arandela Rondelle		
17	0159303	6	Valve guide Ventilführung	Guía de válvula Guide de soupape		
18	0160381	3	Seat-valve, intake Sitz des Einlassventils	Asiento de la válvula de admisión Siège de la soupape		
19	0160382	3	Seat-valve, exhaust Sitz des Auslassventils	Asiento de la válvula de escape Siège de la soupape		
23	0159285	3	Nut Mutter	Tuerca Ecrou		
24	0215494	9	Spacer Abstandsstück	Espaciador Pièce d'écartement		
25	0160380	3	Precombustion chamber Vorkammer	Cámara de precombustión Préchambre		
26	5100026423	1	Cylinder head gasket Zylinderkopfdichtung	Junta de culata del cilindro Joint de culasse de cylindre		
33	0159396	1	Cylinder Gasket Set Dichtungssatz, Zylinder	Juego de juntas, cilindro Jeu de joints, cylindre		
40	0159234	1	Oil Seal Öldichtung	Junta de Aceite Joint D'Huile		
41	0159282	1	Flange Flansch	Brida Bride		
42	0215541	3	Screw Schraube	Tornillo Vis		

Cylinder head cover
Zylinderkopfdeckel
Tapa del cilindro
Couvercle supérieur

DPU110Lec870

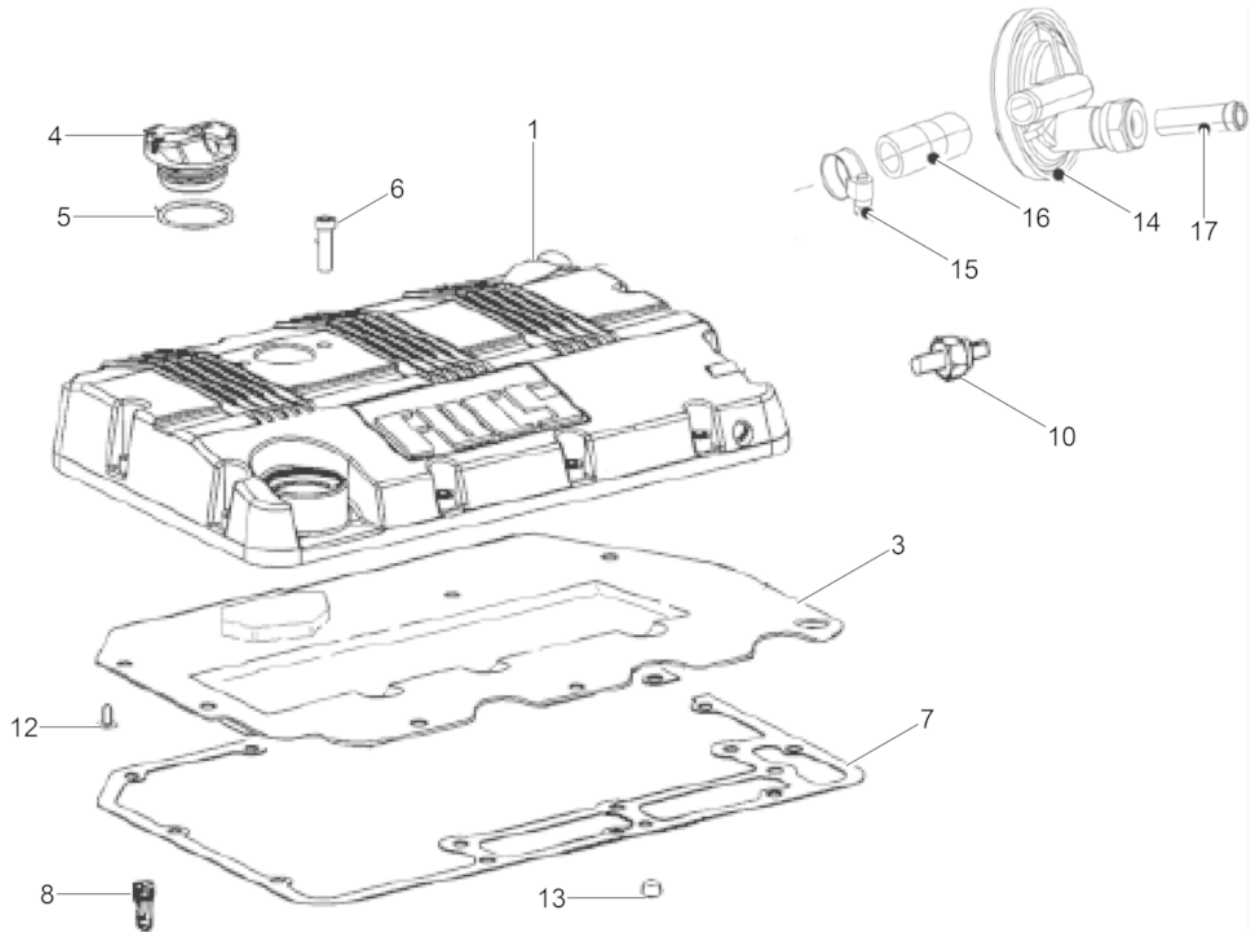

Ref. Pos.	Part No. Artikel Nr.	Qty. St.	Description Beschreibung	Descripción Description	Measurement/Abm.	Norm
					Torque/Drehm.	Sealant Schmierstoff
1	5100026424	1	Cylinder head cover Zylinderkopfdeckel	Tapa del cilindro Couvercle supérieur		
3	0159305	1	Baffle Leitblech	Deflector Déflecteur		
4	0227761	1	Cap Ölverschlußdeckel	Tapa Couvercle		
5	0206208	1	O-ring O-ring	Anillo en forma de o Joint torique		
6	0215541	12	Screw Schraube	Tornillo Vis		
7	0160205	1	Gasket Dichtung	Junta Joint		
8	0159308	1	Connector Anschlußteil	Conector Connexion		
10	5100026419	1	Oil pressure switch Öldruckschalter	Interruptor de presión de acei Interrupteur à pression d'huile		
12	5100008855	9	Rivet Nietnagel	Remache Rivet		
13	0159455	1	Push-in plug Stopfen	Tapón Bouchon		
14	0155745	1	Pressure valve Überdruckventil	Válvula de sobrepresión Soupape de surpression		
15	0160201	4	Clamp Schelle	Abrazadera Attache		
15	0160199	1	Clamp Schelle	Abrazadera Agrafe		
16	0215505	1	Connecting tube Anschlussrohr	Tubo, conexión Tube-branchement		
16	0215535	1	Connecting pipe Anschlussrohr	Tubo, conexión Tube-branchement		
17	0215536	1	Valve tube Ventilschlauch	Tubo, válvula Tube, soupape		

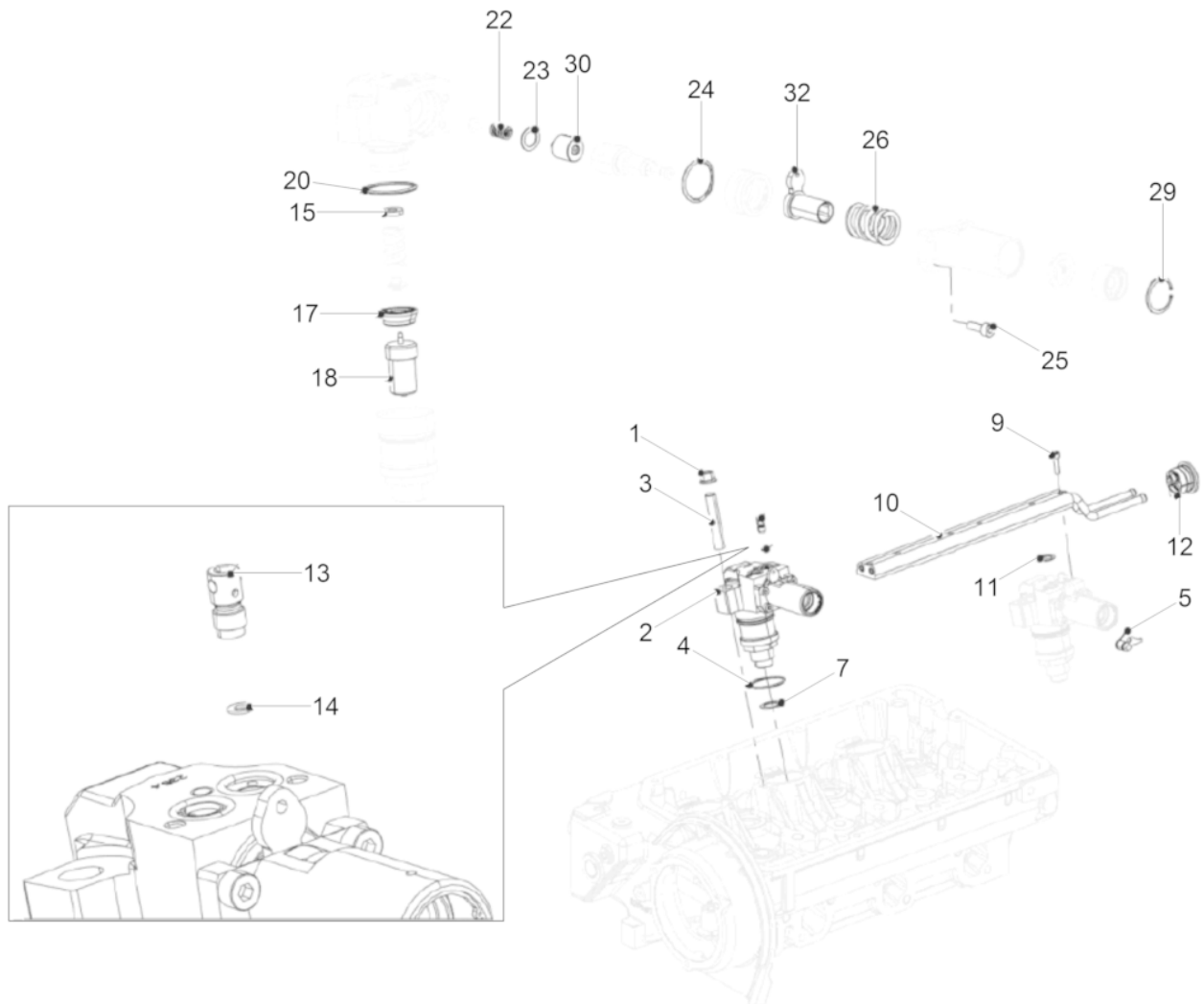

Ref. Pos.	Part No. Artikel Nr.	Qty. St.	Description Beschreibung	Descripción Description	Measurement./Abm.	Norm
					Torque/Drehm.	Sealant Schmierstoff
1	0203358	4	Nut Mutter	Tuerca Écrou		
2	0160379	3	Injection pump Einspritzpumpe	Bomba de inyección Pompe à injection		
3	5200009479	6	Stud Gewindebolzen	Perno prisionero Goujon		
4	0159233	2	O-Ring O-Ring	Anillo-O Joint torique		
5	5100026390	1	Bracket Halterung	Soporte Équerre		
7	0159300	3	Washer Scheibe	Disco Rondelle		
9	0159473	6	Screw Schraube	Tornillo Vis		
10	0159459	1	Pipe Rohr	Tubo Conduit		
11	0159237	2	Ring Ring	Anillo Anneau		
12	0160209	1	Gasket Dichtung	Junta de estanqueidad Garniture		
13	0160391	2	Back pressure valve Rückschlagventil	Válvula de retención Soupape de retenue		
14	0159302	2	Gasket Dichtung	Junta de estanqueidad Garniture		
15	0160332	1	Spacer Abstandsstück	Espaciador Pièce d'écartement		
15	0160342	1	Spacer Abstandsstück	Espaciador Pièce d'écartement		
15	0160340	1	Spacer Abstandsstück	Espaciador Pièce d'écartement		
15	0160339	1	Spacer Abstandsstück	Espaciador Pièce d'écartement		
15	0160338	1	Spacer Abstandsstück	Espaciador Pièce d'écartement		
15	0160337	1	Spacer Abstandsstück	Espaciador Pièce d'écartement		
15	0160336	1	Spacer Abstandsstück	Espaciador Pièce d'écartement		
15	0160335	1	Spacer Abstandsstück	Espaciador Pièce d'écartement		
15	0160334	1	Spacer Abstandsstück	Espaciador Pièce d'écartement		
15	0160341	1	Spacer Abstandsstück	Espaciador Pièce d'écartement		
17	0159278	2	Spacer Abstandsstück	Espaciador Pièce d'écartement		
18	0155710	2	Jet Düse	Chicler Gicleur		
20	0159238	2	O-ring O-Ring	Anillo-O Bague-O		

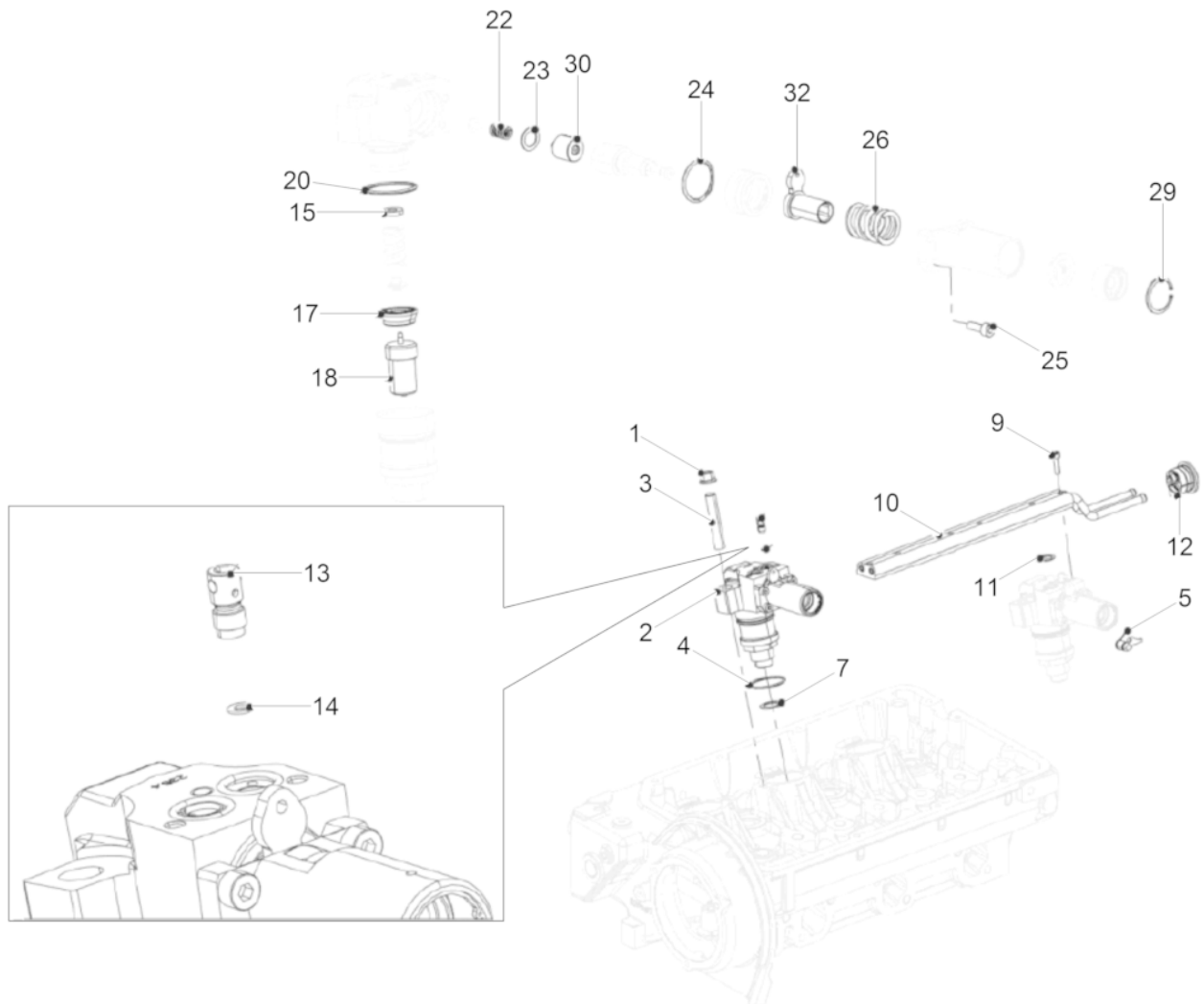

Ref. Pos.	Part No. Artikel Nr.	Qty. St.	Description Beschreibung	Descripción Description	Measurement./Abm.	Norm
					Torque/Drehm.	Sealant Schmierstoff
22	0215509	2	Spring Feder	Resorte Ressort		
23	0203718	2	Cu-Ring Cu-Ring	Cu-Anillo Cu-Anneau		
24	0159236	2	Ring Ring	Anillo Anneau		
25	0159471	4	Screw Schraube	Tornillo Vis		
26	0159317	2	Spring Feder	Resorte Ressort		
29	0159242	2	Clamp Klemme	Abrazadera Pince		
30	5200015520	2	Pressure valve Überdruckventil	Válvula de sobrepresión Soupape de surpression		
32	0159309	2	Shim Ausgleichscheibe	Laminita Cale		

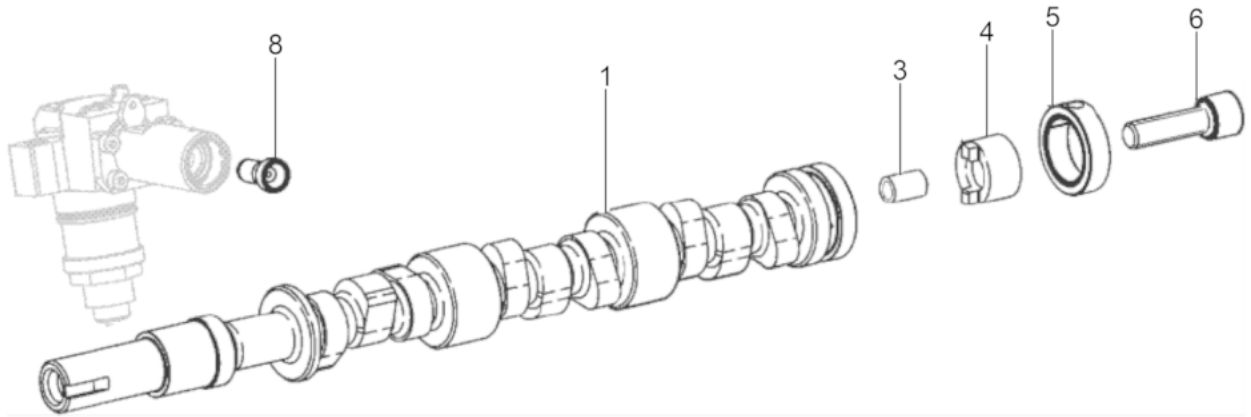

Ref. Pos.	Part No. Artikel Nr.	Qty. St.	Description Beschreibung	Descripción Description	Measurement./Abm.	Norm
					Torque/Drehm.	Sealant Schmierstoff
1	5100026425	1	Camshaft Nockenwelle	Arbol de levas Arbre à cames		
3	0215482	1	Collar Hülse	Collar Douille		
4	0215497	1	Cam Nocken	Leva Came		
5	0160753	1	Injector cam Einspritznocken	Leva inyectora Came d'injection		
6	0215540	1	Screw Schraube	Tornillo Vis		
8	0159246	3	Push rod (valve lifter) Stoßstange	Levantaválvula Poussoir de soupape		

Rocker Arms - Valves
Kipphebel - Ventile
Balancines - Válvulas
Culbuteurs - Soupapes

DPU110Lec870

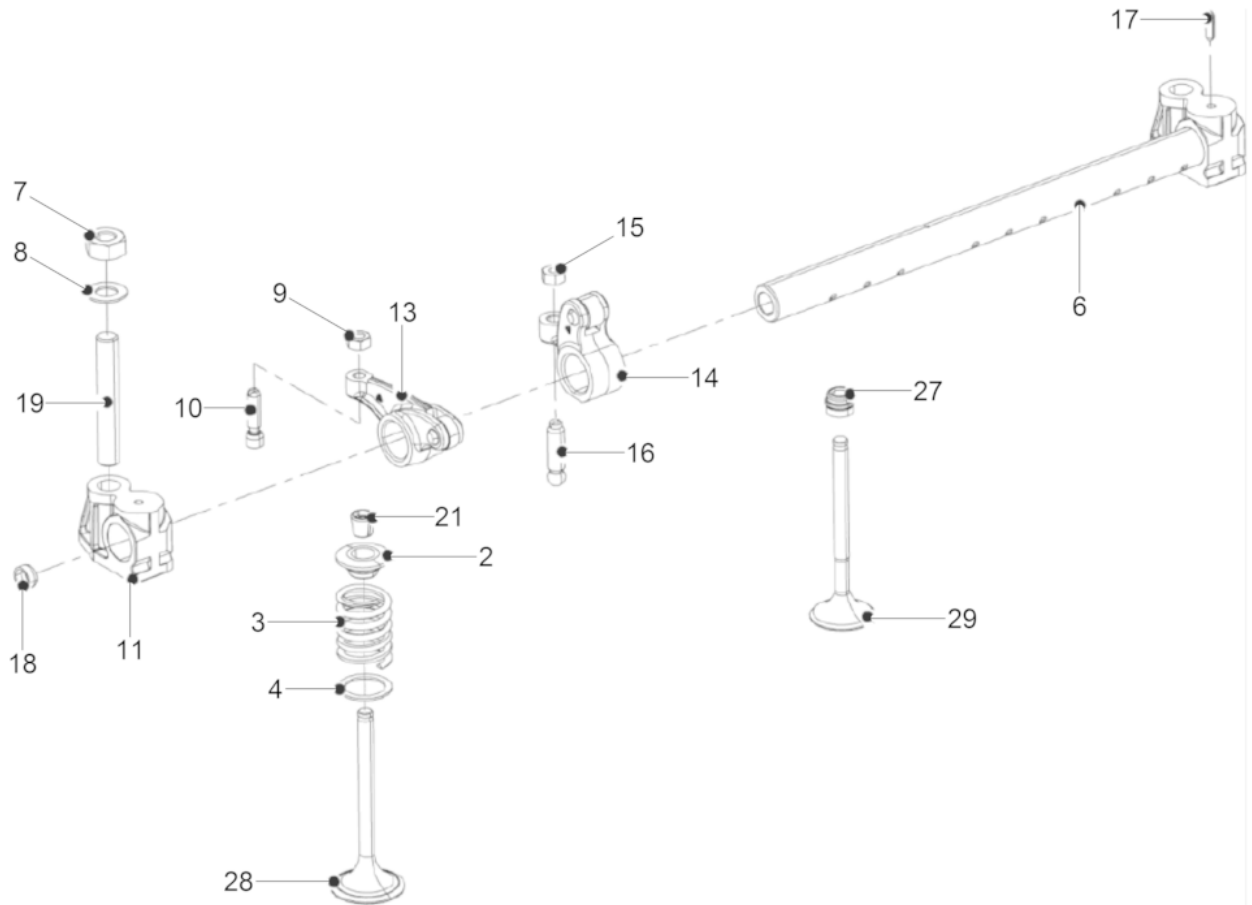

Ref. Pos.	Part No. Artikel Nr.	Qty. St.	Description Beschreibung	Descripción Description	Measurem./Abm.	Norm
					Torque/Drehm.	Sealant Schmierstoff
2	0159328	4	Spring Housing Federgehäuse	Carcasa de Resorte Logement du Ressort		
3	0160373	6	Spring Ventilfeder	Resorte Ressort		
4	0159351	6	Washer Scheibe	Disco Rondelle		
6	0160218	1	Rocker arm shaft Kipphebelwelle	Eje del balancín Arbre du culbuteur		
6	0155696	1	Rocker arm cpl. Kipphebel kpl.	Balancín compl. Culbuteur compl.		
7	0083011	4	Nut Mutter	Tuerca Ecrou		
8	0159350	4	Washer Scheibe	Arandela Rondelle		
9	0159272	1	Nut Mutter	Tuerca Écrou		
10	0159482	1	Screw Schraube	Tornillo Vis		
11	0159447	4	Shaft support Kipphebelbolzenkonsole	Soporte del eje de balancín Support de l'arbre de bascule		
13	0159248	6	Rocker arm Kipphebel	Balancín Culbuteur		
14	0159249	3	Rocker arm injector Kipphebel Einspritzdüse	Inyector de balancines L'injecteur de culbuteur		
15	0159275	1	Nut Mutter	Tuerca Ecrou		
16	0159483	1	Threaded bolt Gewindebolzen	Perno roscado Boulon fileté		
17	0159443	1	Pin Stift	Espiga Goupille		
18	0215529	2	Plug Stopfen	Enchufe Prise		
19	0159333	4	Threaded bolt Gewindebolzen	Perno roscado Boulon fileté		
21	510008856	12	Bush Buchse	Buje Boîte		
27	0159297	6	Gasket Dichtung	Junta Joint		
28	0160390	3	Intake valve Einlaßventil	Válvula de admisión Soupape d'admission		
29	0160392	3	Outlet valve Auslaßventil	Válvula de escape Soupape d'échappement		

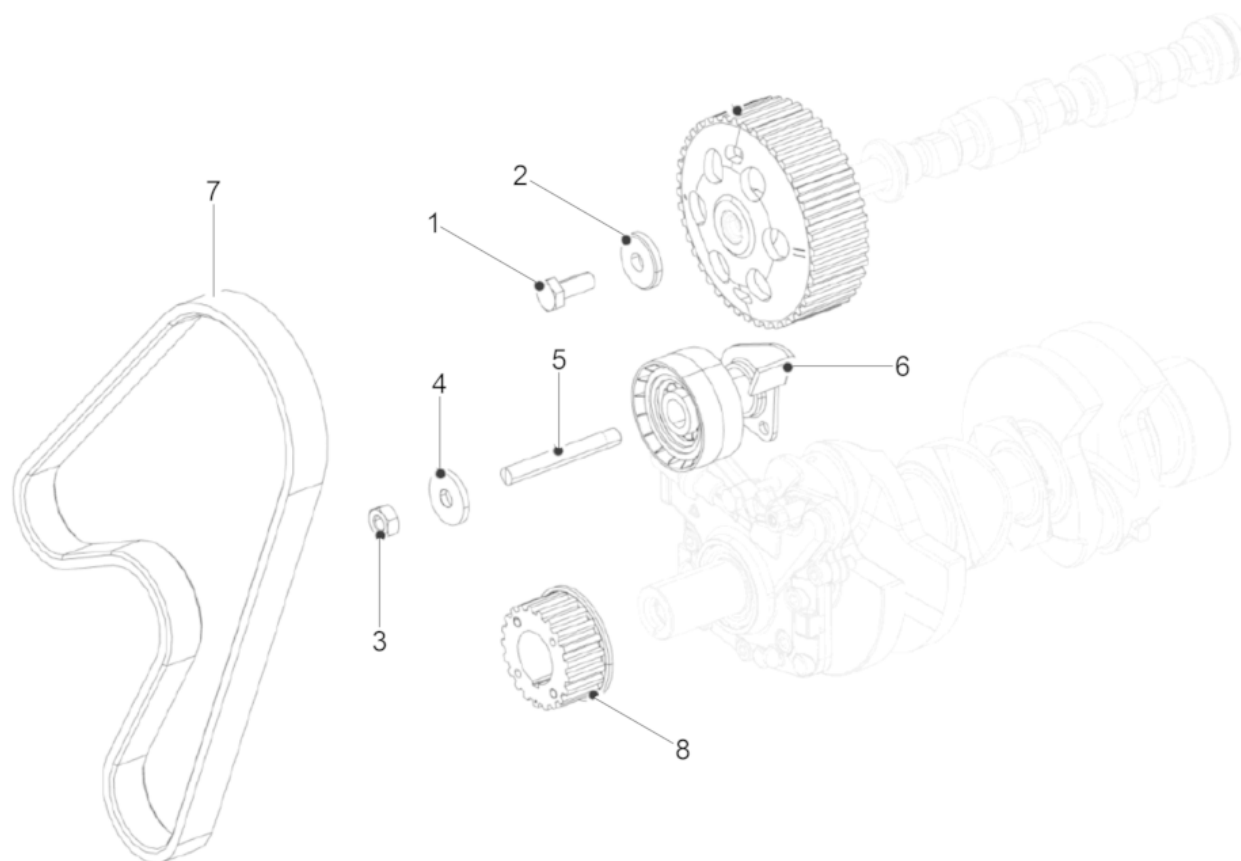

Ref. Pos.	Part No. Artikel Nr.	Qty. St.	Description Beschreibung	Descripción Description	Measurement./Abm.	Norm
					Torque/Drehm.	Sealant Schmierstoff
1	0159481	1	Screw Schraube	Tornillo Vis		
2	0159349	1	Washer Scheibe	Disco Rondelle		
3	0083011	1	Nut Mutter	Tuerca Ecrou		
4	0159344	1	Washer Scheibe	Disco Rondelle		
5	0159334	1	Threaded bolt Gewindebolzen	Perno roscado Boulon fileté		
6	0159284	1	Tensioner pulley Spannrolle	Polea tensora Poulie de tension		
7	0155697	1	Timing belt Synchronriemen	Correa de sincronización Courroie de synchronisation		
8	0159336	1	V-belt pulley Riemenscheibe	Polea Poulie		
9	0159338	1	V-belt pulley Riemenscheibe	Polea Poulie		

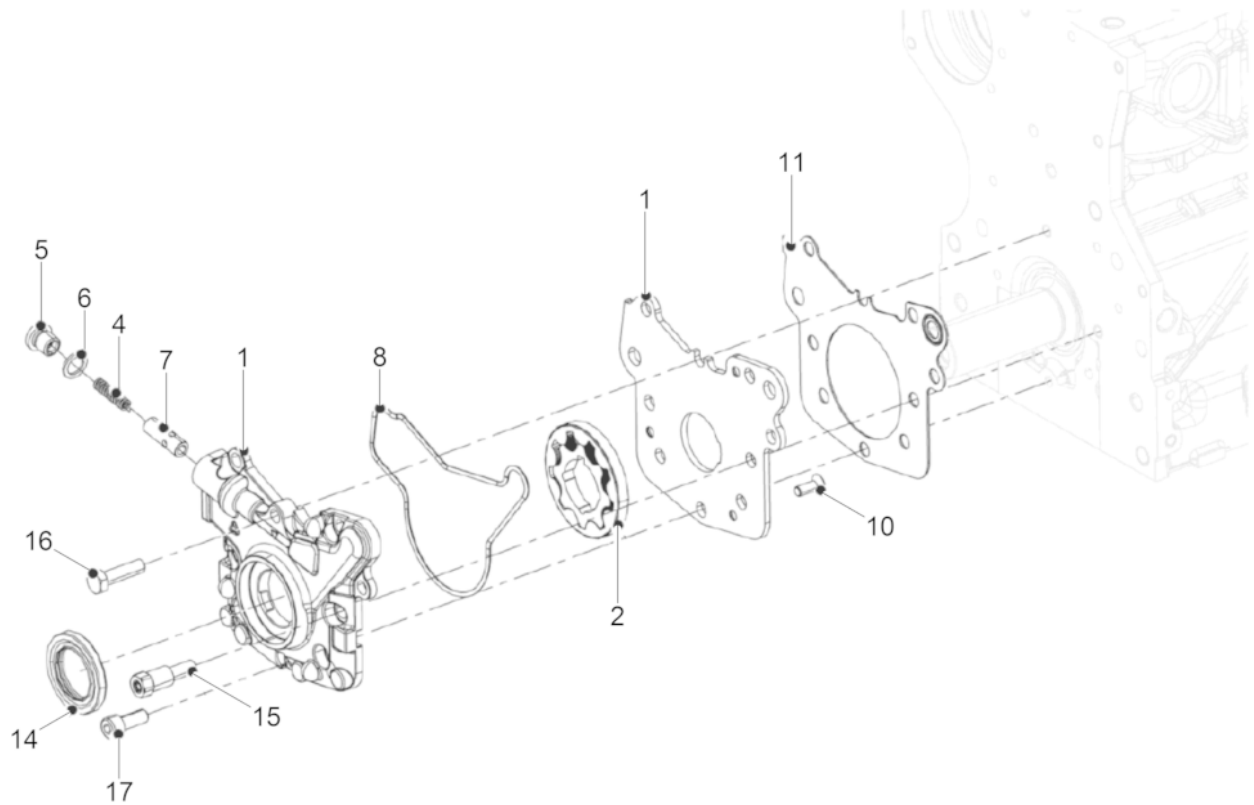

Ref. Pos.	Part No. Artikel Nr.	Qty. St.	Description Beschreibung	Descripción Description	Measurement/Abm.	Norm
					Torque/Drehm.	Sealant Schmierstoff
1	0155735	1	Oil pump cpl. Ölpumpe kpl.	Bomba de aceite compl. Pompe à huile compl.		
2	0160326	1	Rotor Rotor	Rotor Rotor		
4	0159312	1	Spring Feder	Resorte Ressort		
5	0159450	1	Screw Locking Schraubverschluß	Cierre Roscada Fermeture de Vissage		
6	0082184	1	Ring seal Dichtring	Anillo sellador Rondelle à étancher		
7	0159330	1	Rod Stange	Varilla Tige		
8	0160178	1	O-Ring O-Ring	Anillo-O Joint torique		
10	0159478	3	Screw Schraube	Tornillo Vis		
11	0215709	1	Gasket Dichtung	Junta de estanqueidad Garniture		
14	0155734	1	Ring seal Dichtungsring	Anillo sellador Rondelle à étancher		
15	0159484	2	Screw Schraube	Tornillo Vis		
16	0215479	1	Hexagonal head cap screw Sechskantschraube	Tornillo hexagonal Vis à tête hexagonale		
17	0084169	6	Screw Schraube	tornillo vis		

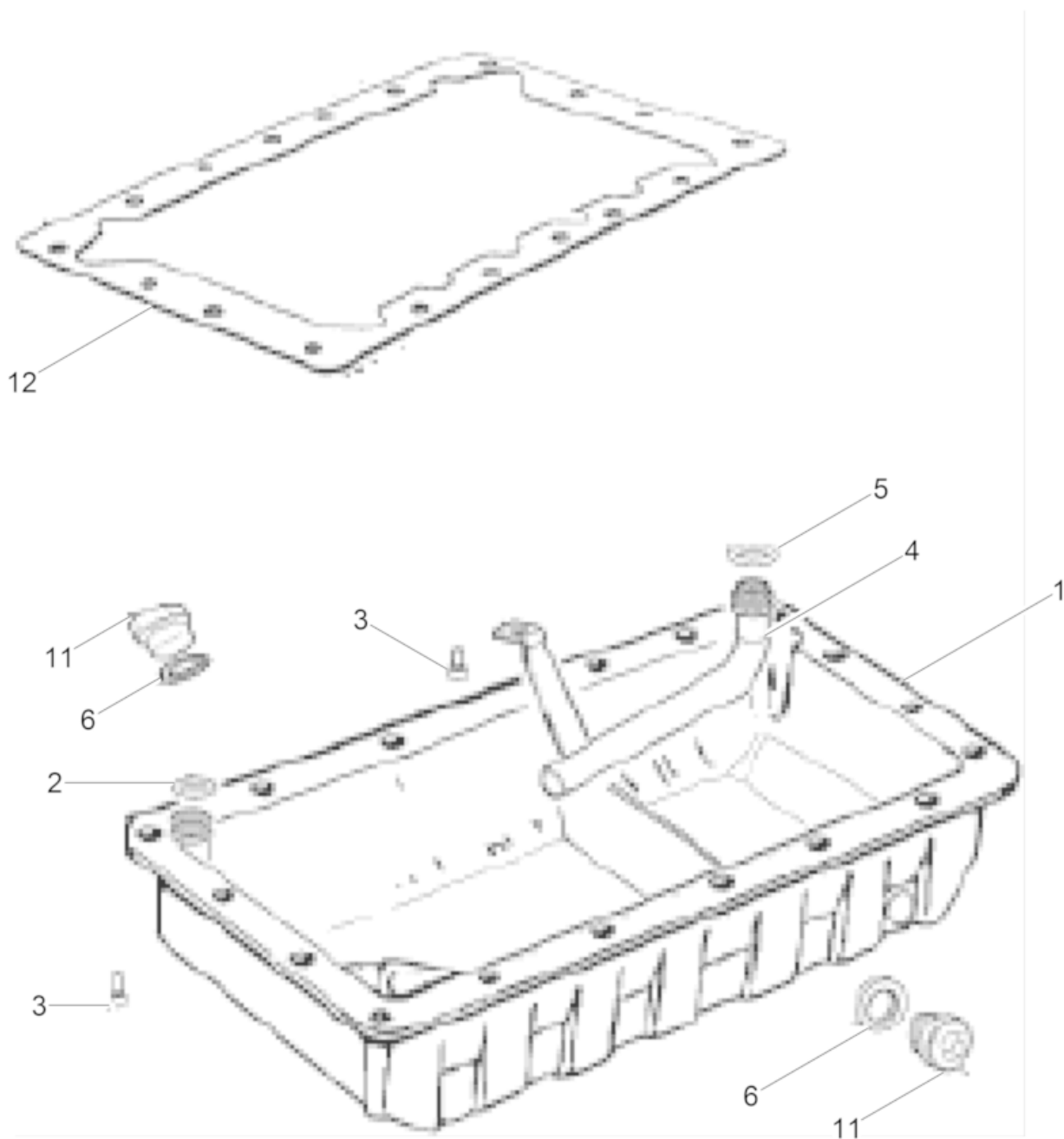

Ref. Pos.	Part No. Artikel Nr.	Qty. St.	Description Beschreibung	Descripción Description	Measurement./Abm.	Norm
					Torque/Drehm.	Sealant Schmierstoff
1	0155738	1	Oil pan Ölwanne	Colector de aceite Cuvette-carter à huile		
2	0159228	1	Oil Seal Öldichtung	Junta de Aceite Joint D'Huile		
3	0159253	19	Bolt Bolzen	Perno Boulon		
4	0155737	1	Hose Schlauch	Manguera Tuyau		
5	0159235	1	O-Ring O-Ring	Anillo-O Joint torique		
6	0159568	2	Washer Scheibe	Arandela Rondelle		
11	0211364	2	Screw Plug Verschlusschraube	Tapón Roscado Vis de Fermeture		
12	0159291	2	Gasket Dichtung	Junta Joint		

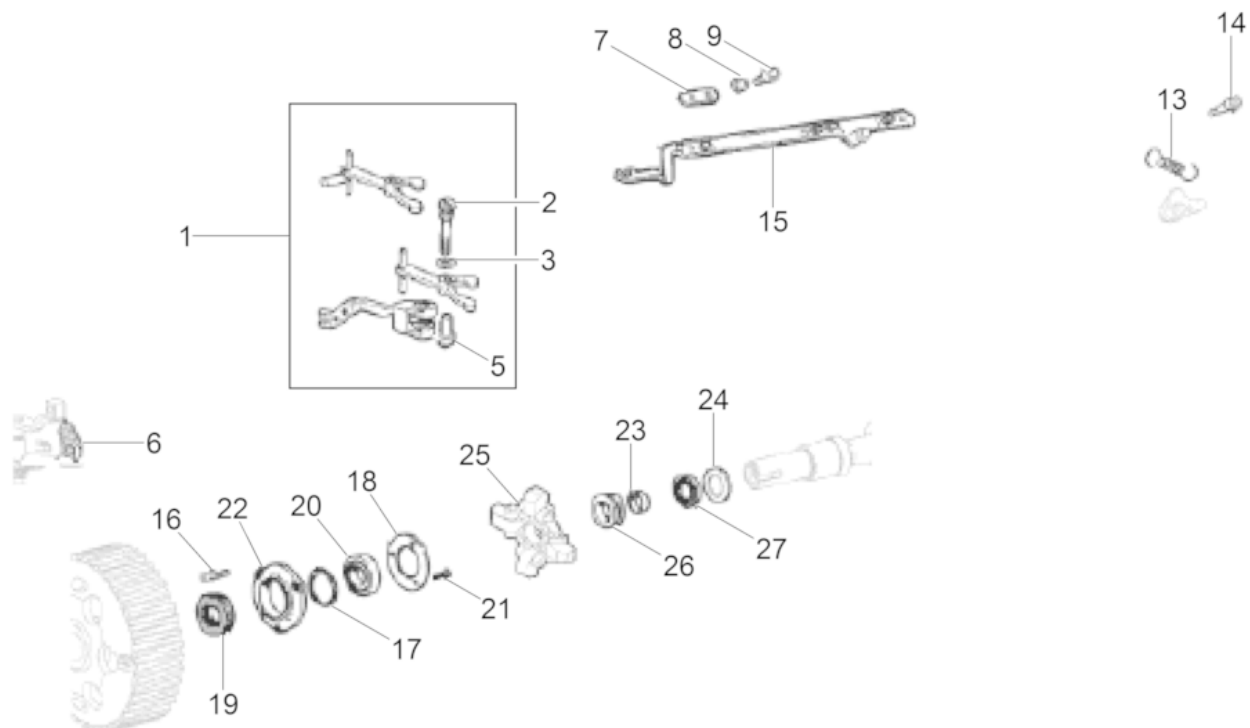

Ref. Pos.	Part No. Artikel Nr.	Qty. St.	Description Beschreibung	Descripción Description	Measur./Abm.	Norm
					Torque/Drehm.	Sealant Schmierstoff
1	0159304	1	Governor lever cpl. Reglerhebel kpl.	Palanca de regulador cpl. Levier régulateur cpl.		
2	0159321	1	Pin Stift	Espiga Goupille		
3	0159229	1	Oil Seal Öldichtung	Junta de Aceite Joint D'Huile		
5	0215480	1	Collar Hülse	Collar Douille		
6	0215507	1	Spring Feder	Resorte Ressort		
7	0217813	1	Plate Platte	Placa Plaque		
8	0215520	2	Washer Scheibe	Disco Rondelle		
9	0159477	4	Screw Schraube	Tornillo Vis		
13	0159315	1	Spring Feder	Resorte Ressort		
14	0211941	3	Screw Schraube	Tornillo Vis		
15	0159245	1	Linkage Gestänge	Varillaje Tringles		
16	0159467	3	Cover Deckel	Cubierta Couvercle		
17	0159239	1	O-Ring O-Ring	Anillo-O Joint torique		
18	0159324	1	Check disc Anlaufscheibe	Arandela tope Disque		
19	0159240	1	Lip seal Lippendichtung	Retén labial Joint à lèvres		
20	0159267	1	Collar Hülse	Collar Douille		
21	5100008841	3	Screw Schraube	Tornillo Vis		
22	0159265	1	Cover Deckel	Cubierta Couvercle		
23	0159251	1	Collar Hülse	Collar Douille		
24	0215517	1	Check disc Anlaufscheibe	Arandela tope Disque		
25	0155698	1	Speed control module Drehzahlregler	Controlador de velocidad Régulateur de vitesse		
26	0215506	1	Collar Hülse	Collar Douille		
27	0217805	1	Bearing Anlauflager	Cojinete Palier		

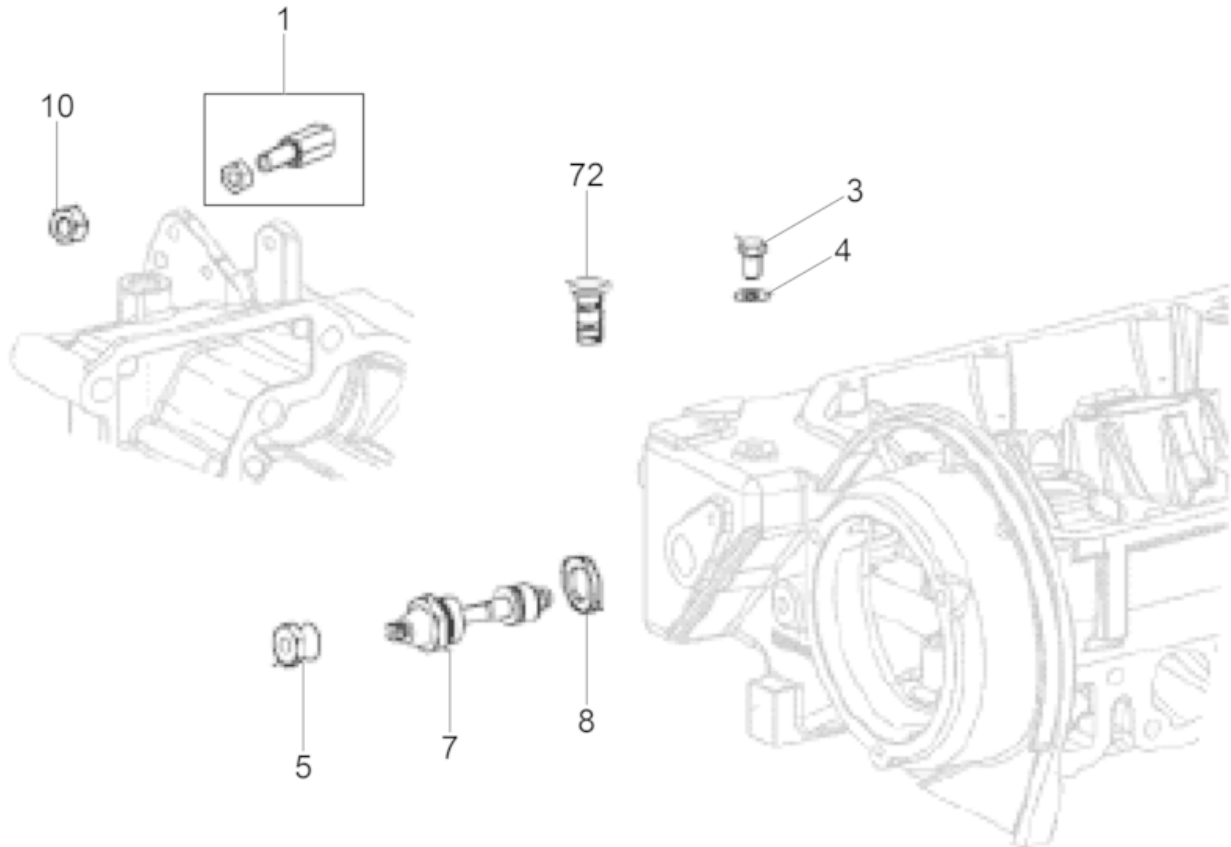

Ref. Pos.	Part No. Artikel Nr.	Qty. St.	Description Beschreibung	Descripción Description	Measurem./Abm.	Norm
					Torque/Drehm.	Sealant Schmierstoff
1	0209040	1	Screw Einstellschraube	Tornillo Vis		
3	0084131	2	Screw Schraube	Tornillo Vis		
4	0083995	2	Washer Scheibe	Arandela Rondelle		
5	0159276	1	Nut Mutter	Tuerca Écrou		
7	0215525	1	Fuel valve Kraftstoffhahn	Grifo de combustible Robinet de carburant		
8	0159292	1	Gasket Dichtung	Junta de estanqueidad Garniture		
10	0159272	1	Nut Mutter	Tuerca Écrou		
72	0215528	1	Plug Stopfen	Tapón Bouchon		

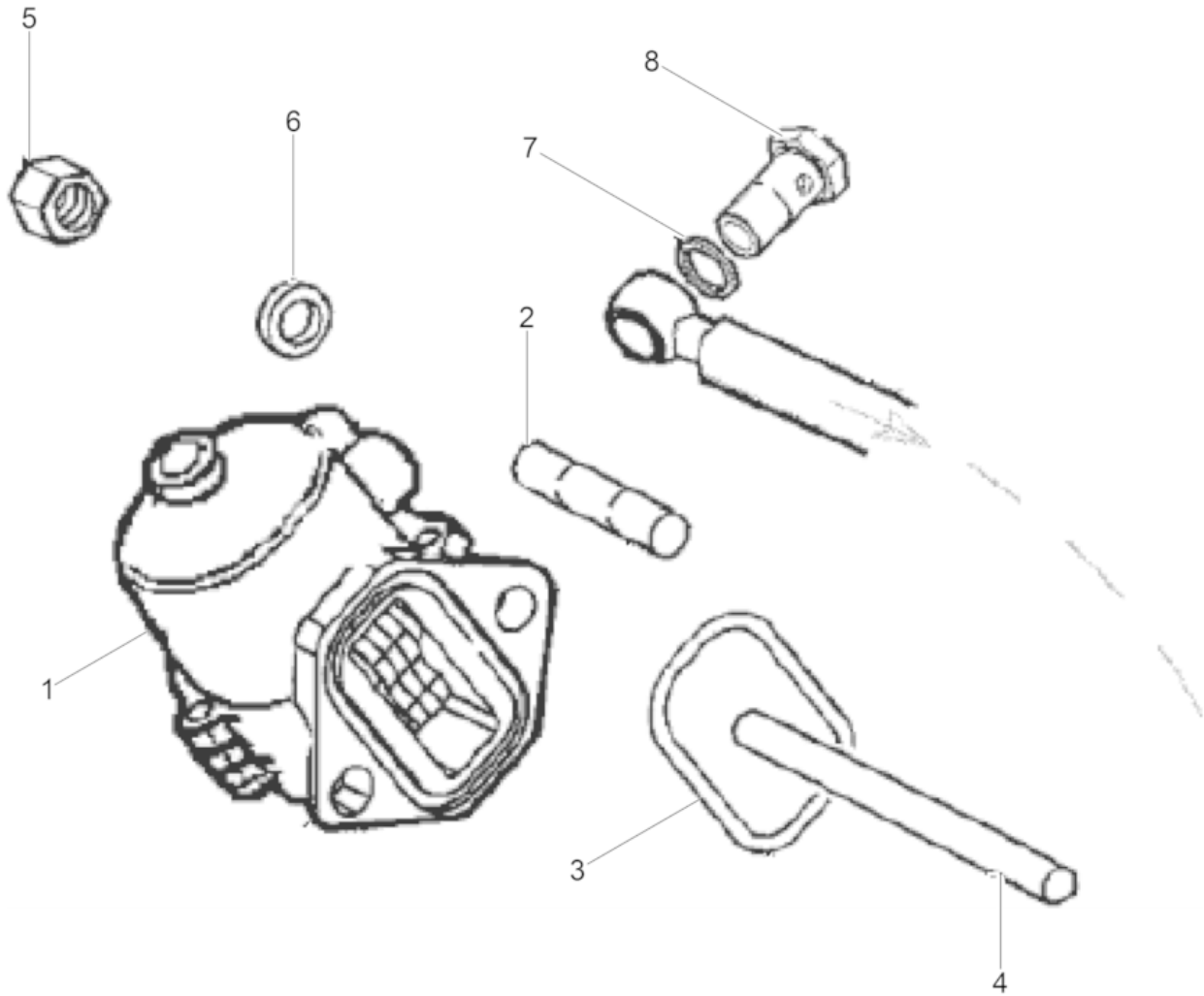

Ref. Pos.	Part No. Artikel Nr.	Qty. St.	Description Beschreibung	Descripción Description	Measurement./Abm.	Norm
					Torque/Drehm.	Sealant Schmierstoff
1	0226239	1	Fuel Pump Kraftstoffpumpe	Bomba de Combustible Pompe à Essence		
2	0082266	2	Stud Stiftschraube	Perno prisionero Boulon		
3	0110759	1	Seal Dichtung	Junta Joint		
4	0160757	1	Rod Stange	Varillae Tige		
5	0203358	2	Nut Mutter	Tuerca Écrou		
6	0082285	2	Washer Scheibe	Arandela Rondelle		
7	0082183	4	Ring seal Dichtring	Anillo sellador Rondelle à étancher		
8	0217802	2	Banjo bolt Hohlschraube	Perno hueco Boulon creux à filet femelle		

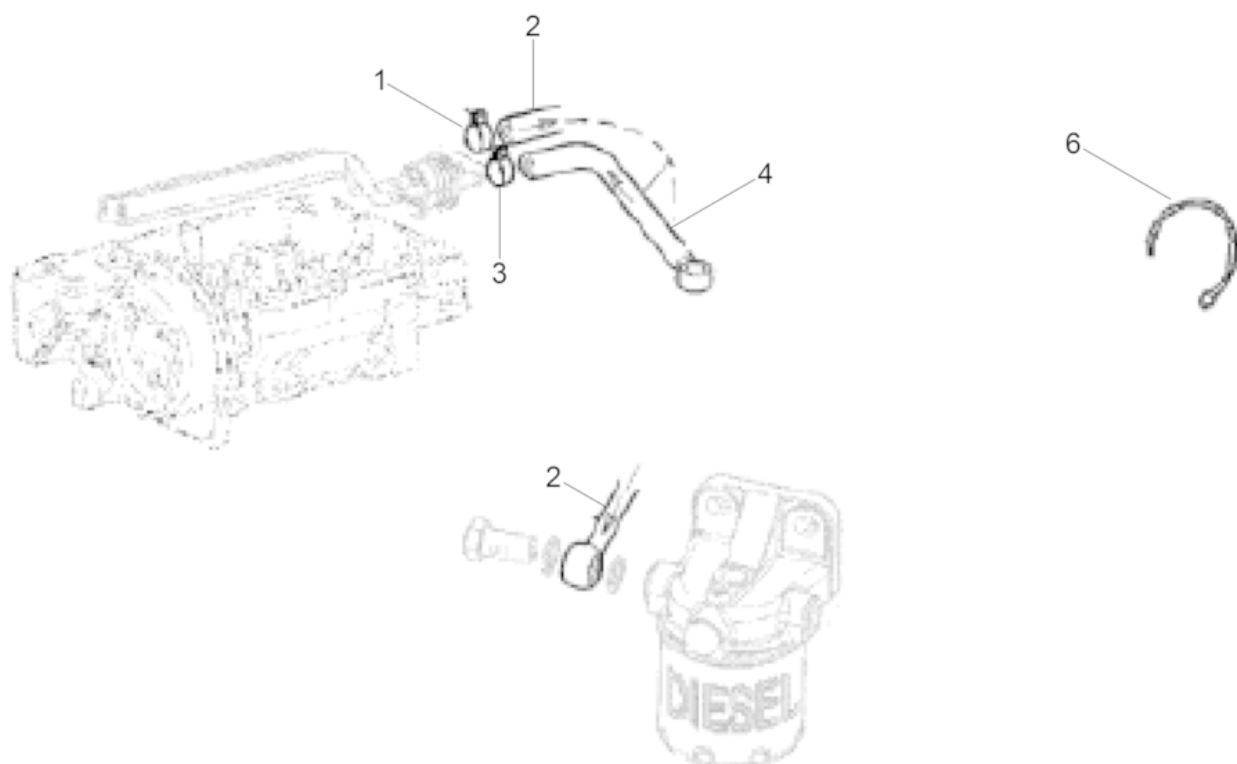

Ref. Pos.	Part No. Artikel Nr.	Qty. St.	Description Beschreibung	Descripción Description	Measurem./Abm.	Norm
					Torque/Drehm.	Sealant Schmierstoff
1	0082155	1	Clamp Schelle	Abrazadera Collier		
2	5100026403	1	Fuel hose Kraftstoffschlauch	Manguera de combustible Tuyau à essence		
3	0215704	1	Clamp Schelle	Abrazadera Attache		
4	5100026404	1	Fuel hose Kraftstoffschlauch	Manguera de combustible Tuyau à essence		
6	0215486	3	Collar Manschette	Collar Collet		

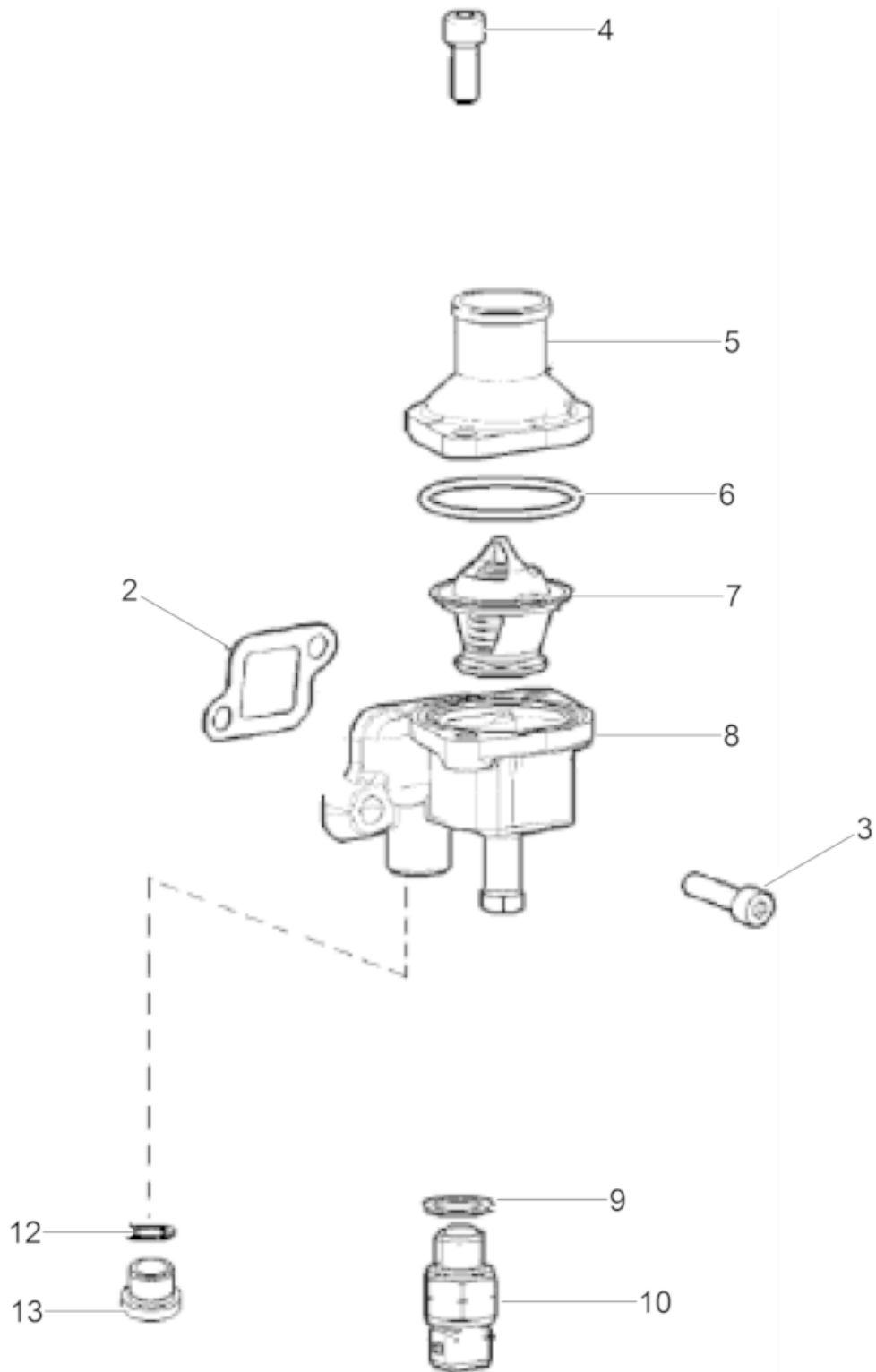

Ref. Pos.	Part No. Artikel Nr.	Qty. St.	Description Beschreibung	Descripción Description	Measurement/Abm.	Norm
					Torque/Drehm.	Sealant Schmierstoff
2	0211378	1	Gasket Dichtung	Junta de estanqueidad Garniture		
3	0159476	2	Screw Schraube	Tornillo Vis		
4	0084169	2	Screw Schraube	tornillo vis		
5	5100030694	1	Casing adaptor Anschlussstück	Pieza de conexión Pièce de raccordement		
6	0159232	1	O-Ring O-Ring	Anillo-O Joint torique		
7	0207002	1	Valve-thermostat Thermostatventil	Válvula de gobierno termostático Soupape thermostatique		
8	0215489	1	Thermostat housing Temperaturreglergehäuse	Caja del termóstato Carter du thermostat		
9	0203712	1	Cu-Ring Cu-Ring	Cu-Anillo Cu-Anneau		
10	5100005738	1	temperature sensor Temperaturfühler	elemento térmico détecteur thermique		
12	0159299	1	Washer Scheibe	Disco Rondelle		
13	0159451	1	Screw Plug Verschlusschraube	Tapón Roscado Vis de Fermeture		

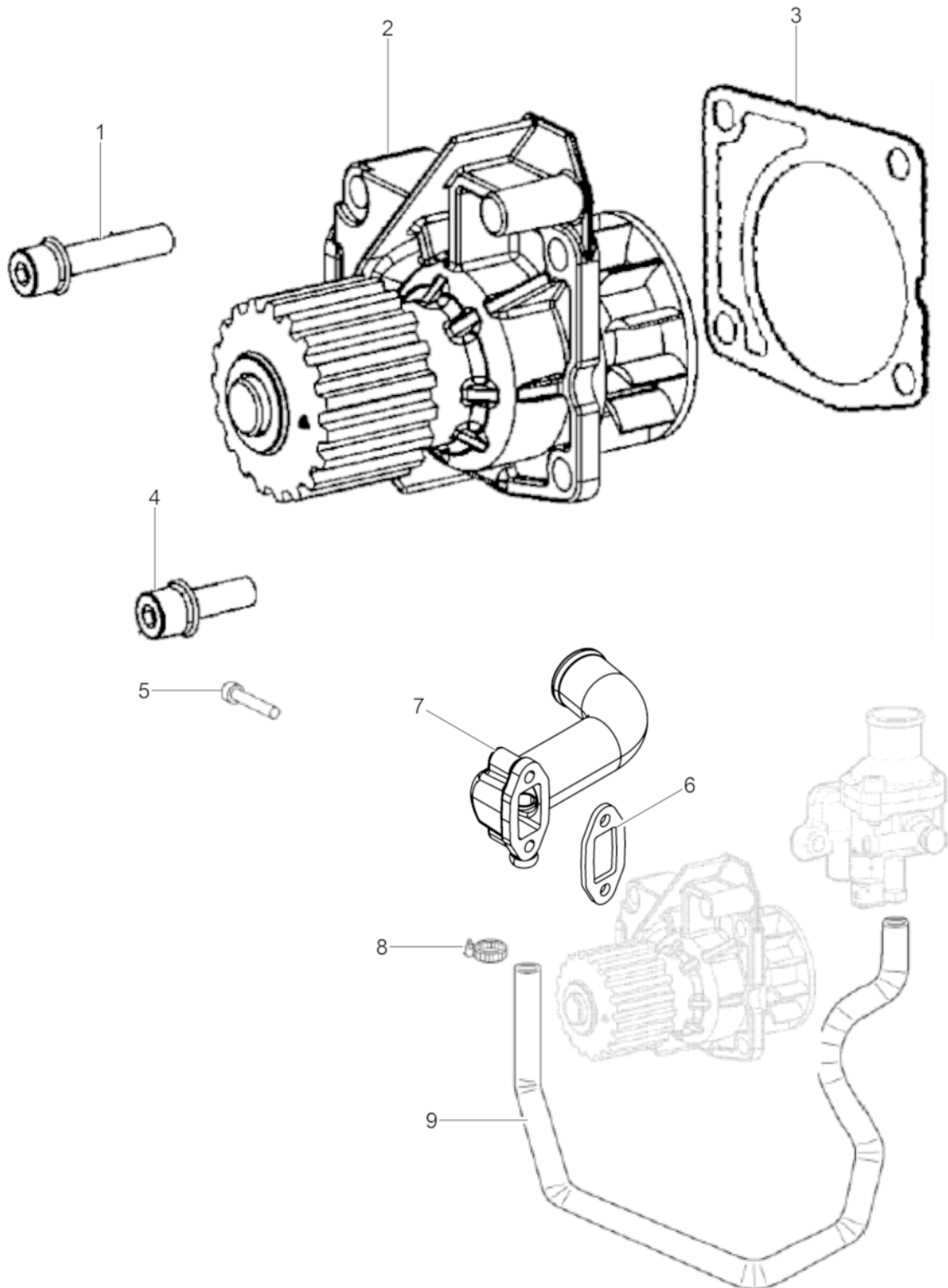

Ref. Pos.	Part No. Artikel Nr.	Qty. St.	Description Beschreibung	Descripción Description	Measurement/Abm.	Norm
					Torque/Drehm.	Sealant Schmierstoff
1	0209105	2	Hexagonal head cap screw Sechskantschraube	Tornillo hexagonal Vis à tête hexagonale		
2	5100026407	1	Water Pump Wasserpumpe	Bomba de agua Pompe d'eau		
3	0217809	1	Gasket Dichtung	Junta de estanqueidad Garniture		
4	0209107	2	Hexagonal head cap screw Sechskantschraube	Tornillo hexagonal Vis à tête hexagonale		
5	0160362	2	Screw Schraube	Tornillo Vis		
6	0217808	1	Gasket Dichtung	Junta de estanqueidad Garniture		
7	5100026405	1	Flange Flansch	Brida Bride		
8	0160201	2	Clamp Schelle	Abrazadera Attache		
9	5100026406	1	Hose Schlauch	Manguera Tuyau		

Inlet bend
Ansaugkrümmer
Codo de aspiración
Coude d'aspiration

DPU110Lec870

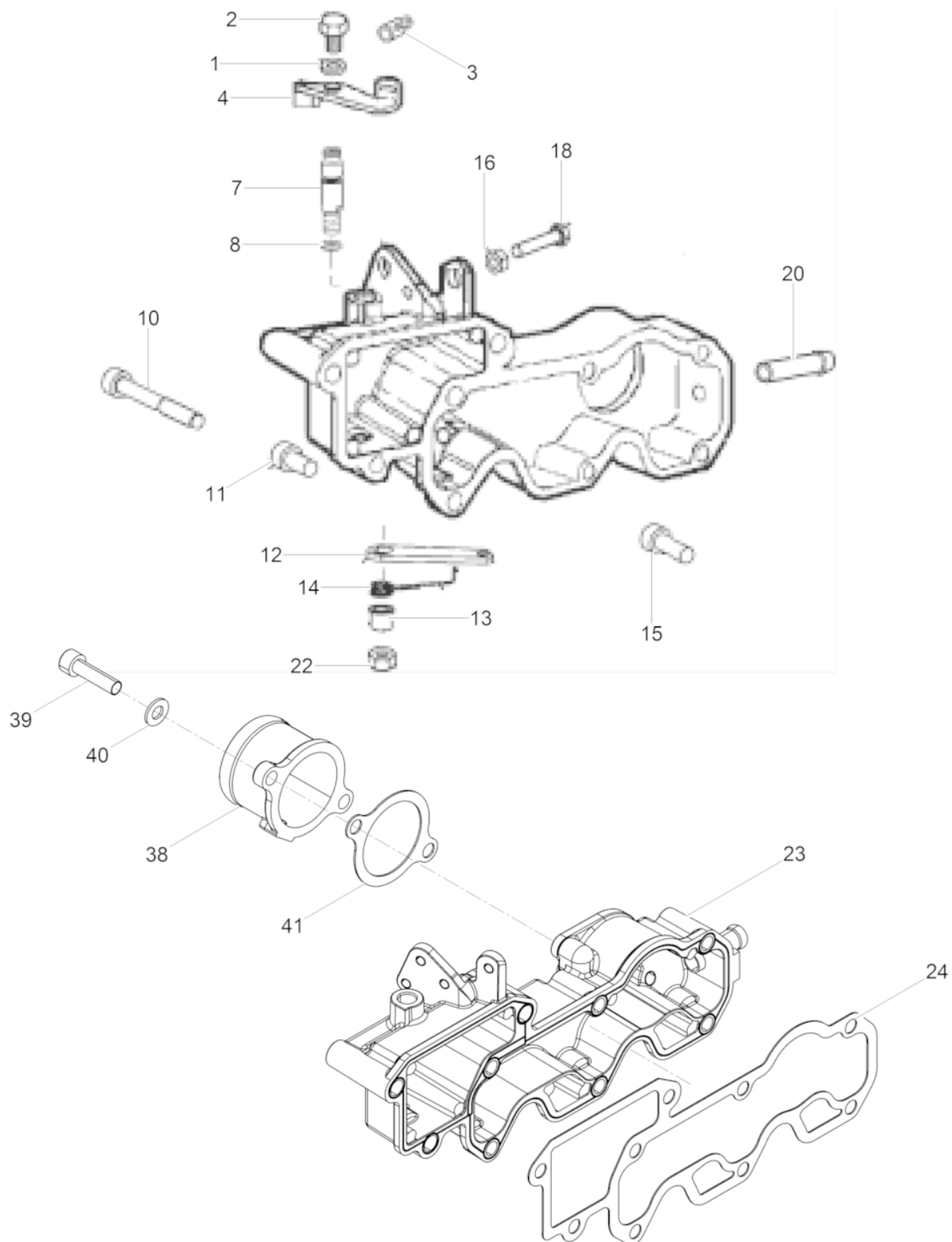

Ref. Pos.	Part No. Artikel Nr.	Qty. St.	Description Beschreibung	Descripción Description	Measurem./Abm.	Norm
					Torque/Drehm.	Sealant Schmierstoff
1	0217817	1	Washer Scheibe	Disco Rondelle		
2	0217801	1	Hexagonal head cap screw Sechskantschraube	Tornillo hexagonal Vis à tête hexagonale		
3	0203352	1	Clamping piece Klemmstück	Pieza de fijación Pièce de serrage		
4	0217810	1	Lever Hebel	Palanca Levier		
7	5100008860	1	Shaft Welle	Eje Arbre		
8	0159230	1	Oil Seal Öldichtung	Junta de Aceite Joint D'Huile		
10	0084170	1	Screw Schraube	Tornillo Vis		
11	0159476	3	Screw Schraube	Tornillo Vis		
12	0215504	1	Lever Hebel	Palanca Levier		
13	0215481	1	Collar Hülse	Collar Douille		
14	0215508	1	Spring Feder	Resorte Ressort		
15	0203346	4	Screw Schraube	tornillo vis		
16	0159272	2	Nut Mutter	Tuerca Écrou		
18	5100008861	2	Hexagonal head cap screw Sechskantschraube	Tornillo hexagonal Vis à tête hexagonale		
20	0159462	1	Hose Schlauch	Manguera Boyau		
22	0084232	1	Nut Mutter	Tuerca Ecrou		
23	0215487	1	Manifold inlet Verteiler, Einlass	Distribuidor, admisión Tubulure, admission		
24	0160186	1	Intake manifold gasket Ansaugkrümmerdichtung	Junta-distribuidor de admisión Joint-collecteur d'admission		
38	5100026411	1	Flange Flansch	Brida Bride		
39	0084169	2	Screw Schraube	tornillo vis		
40	0082285	2	Washer Scheibe	Arandela Rondelle		
41	5100026429	1	Gasket Dichtung	Junta Joint		

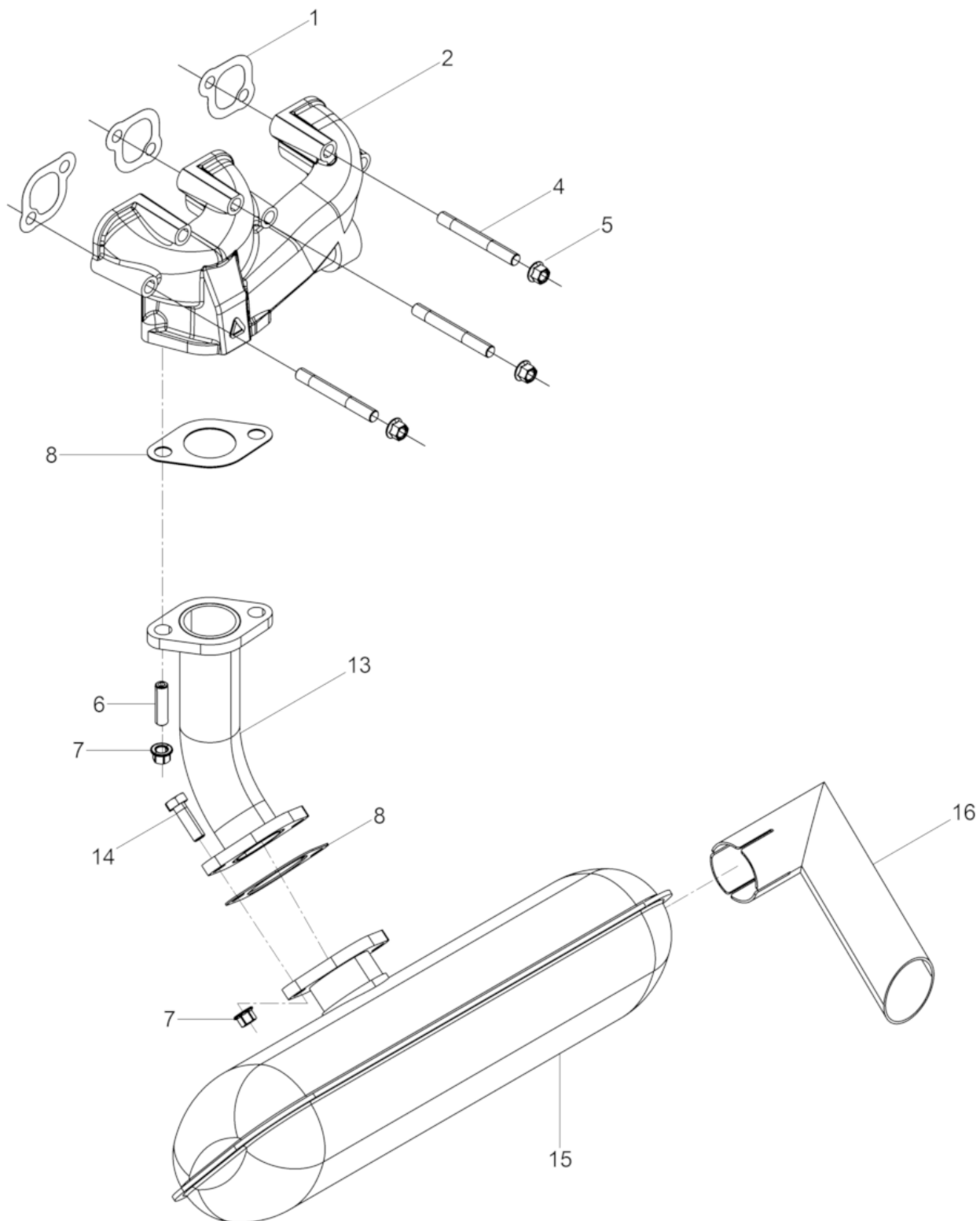

Ref. Pos.	Part No. Artikel Nr.	Qty. St.	Description Beschreibung	Descripción Description	Measurement./Abm.	Norm
					Torque/Drehm.	Sealant Schmierstoff
1	0159290	3	Gasket Dichtung	Junta de estanqueidad Garniture		
2	0159263	1	Exhaust manifold Auspuffkrümmer	Distribuidor de escape Collecteur d'échappement		
4	0082267	6	Stud Gewindebolzen	Perno prisionero Boulon		
5	0086331	6	Nut Mutter	Tuerca Écrou		
6	0160228	2	Threaded bolt Gewindebolzen	Perno roscado Boulon fileté	M8x22	
7	0086331	4	Nut Mutter	Tuerca Écrou		
8	0159295	2	Gasket Dichtung	Junta de estanqueidad Garniture		
13	5100005701	1	Exhaust pipe Auspuffrohr	Tubo de escape Tube d'échappement		
14	0215479	2	Hexagonal head cap screw Sechskantschraube	Tornillo hexagonal Vis à tête hexagonale		
15	5100005522	1	Muffler Schalldämpfer	Silenciador Silencieux		
16	5100005702	1	Exhaust-Pipe End Auspuffendrohr	Extremo de la Extractor-Pipa Extrémité de Échappement-Pipe		

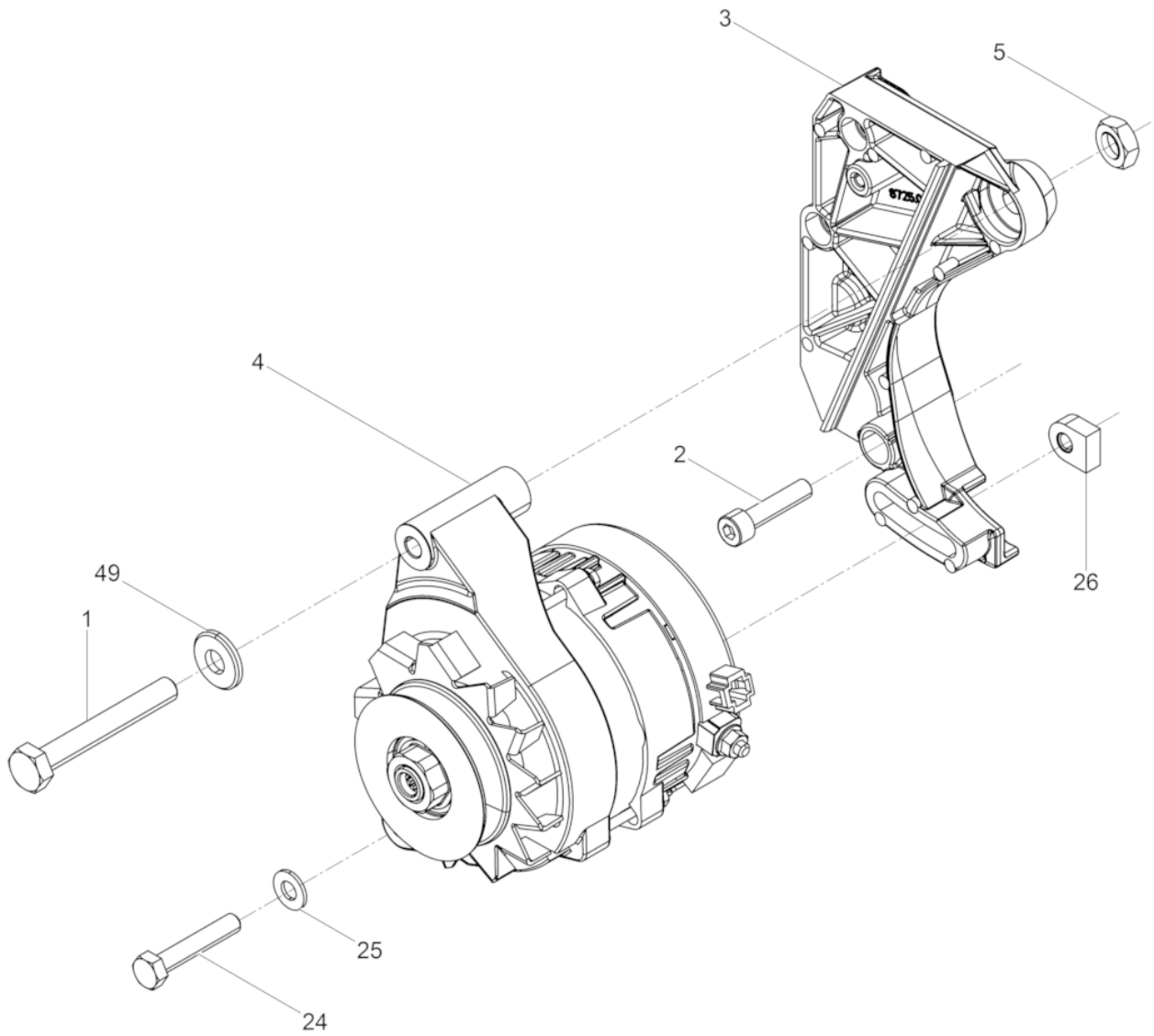

Ref. Pos.	Part No. Artikel Nr.	Qty. St.	Description Beschreibung	Descripción Description	Measurement./Abm.	Norm
					Torque/Drehm.	Sealant Schmierstoff
1	5100026414	1	Hexagonal head cap screw Sechskantschraube	Tornillo hexagonal Vis à tête hexagonale		
2	0159476	3	Screw Schraube	Tornillo Vis		
3	5100026415	1	Bracket Halterung	Soporte Équerre		
4	5100026416	1	Alternator Lichtmaschine	Alternador Alternateur		
5	0083011	1	Nut Mutter	Tuerca Ecrou		
24	0208993	1	Hexagonal head cap screw Sechskantschraube	Tornillo hexagonal Vis à tête hexagonale		
25	0082293	1	Washer Scheibe	Arandela Rondelle		
26	5100026417	1	Clamp Klemme	Abrazadera Pince		
49	5100026418	1	Disc Scheibe	Disco Disque		

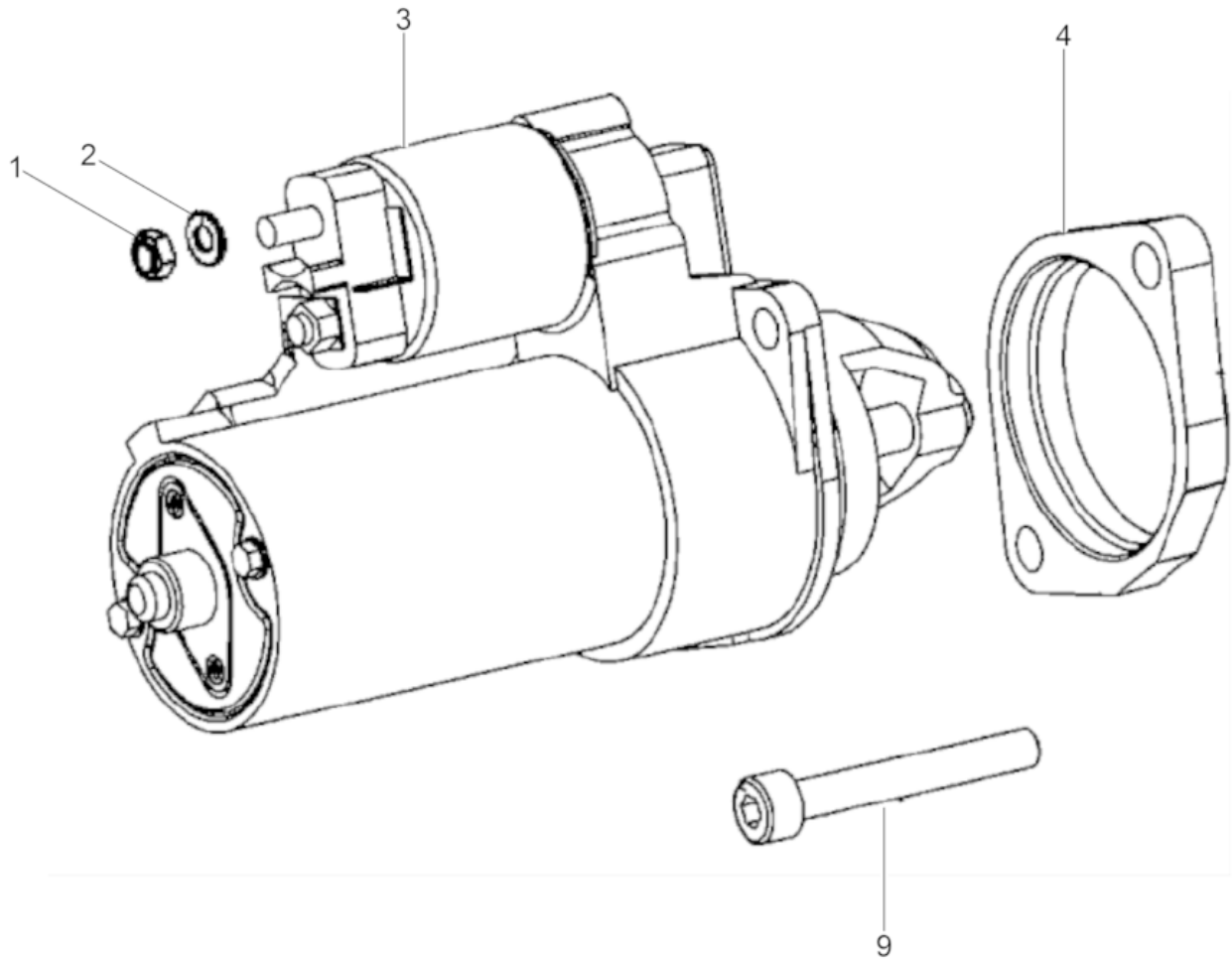

Ref. Pos.	Part No. Artikel Nr.	Qty. St.	Description Beschreibung	Descripción Description	Measurement./Abm.	Norm
					Torque/Drehm.	Sealant Schmierstoff
1	0215493	1	Hexagon nut Sechskantmutter	Tuerca hexagonal Écrou hexagonal		
2	0082288	1	Washer Scheibe	Arandela Rondelle		
3	0211380	1	Starter Anlasser	Arrancador Démarrreur		
4	0206968	1	Flange Flansch	Brida Bride		
9	0083027	2	Screw Schraube	Tornillo Vis		

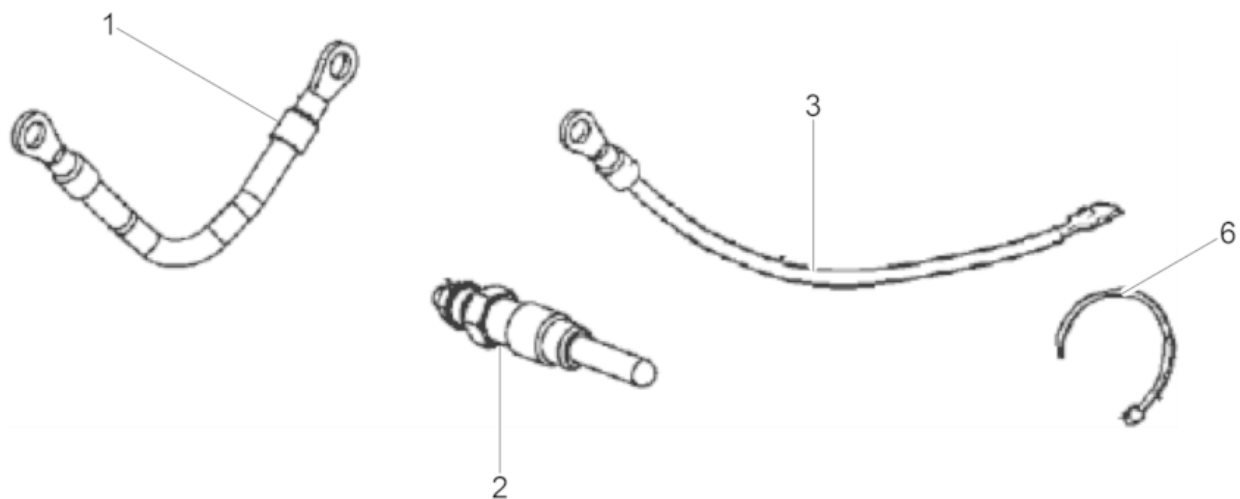

Ref. Pos.	Part No. Artikel Nr.	Qty. St.	Description Beschreibung	Descripción Description	Measurement./Abm.	Norm
					Torque/Drehm.	Sealant Schmierstoff
1	0159259	2	Cable Kabel	Cable Câble		
2	0155748	3	Glow plug Glühkerze	Tapón luminoso Bougie de préchauffage		
3	5100026470	1	Wire, Glow plug Kabel, Glühkerze	Cable, Tapón luminoso Cable, Bougie de préchauffage		
6	0209062	1	Tie cable Kabelbinder	Fijación Attache		

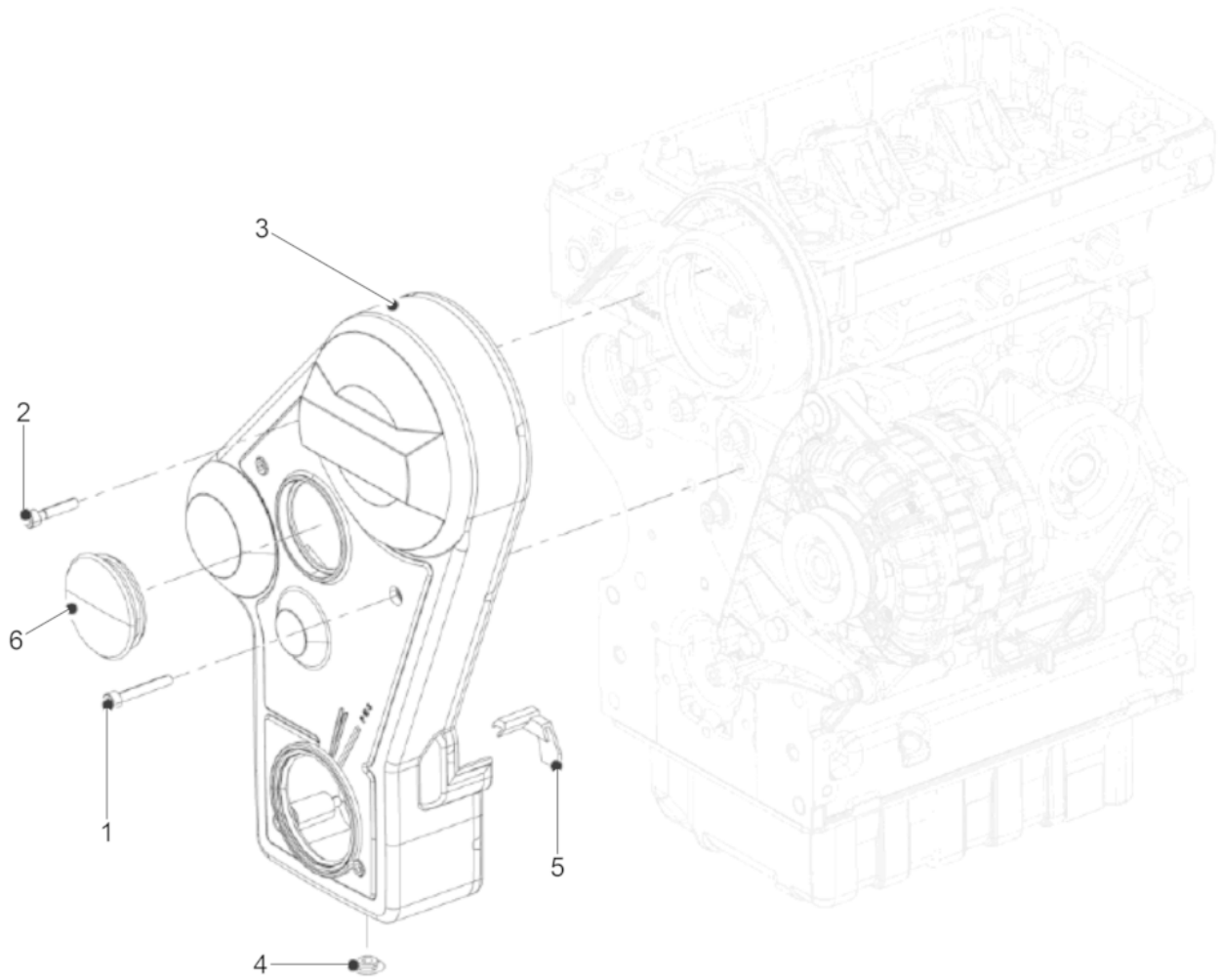

Ref. Pos.	Part No. Artikel Nr.	Qty. St.	Description Beschreibung	Descripción Description	Measurement./Abm.	Norm
					Torque/Drehm.	Sealant Schmierstoff
1	0159564	1	Screw Schraube	Tornillo Vis		
2	0159475	4	Screw Schraube	tornillo vis		
3	5100026420	1	Belt guard Keilriemenschutz	Protección de la polea Protection de courroie		
4	0159268	1	Plug Stopfen	Enchufe Prise		
5	0215499	1	Gasket Dichtung	Junta de estanqueidad Garniture		
6	5100026421	1	Protective cover Schutzdeckel	Tapa de protección Couverture de protection		



**WACKER
NEUSON**