



**WACKER
NEUSON**

5100018327	101
12.2016	

**Single Direction Plates
Vorwärtslaufende Platten
Planchas Vibradoras Unidirecc
Plaques Vibrantes à sens de ma**

WP1540Aw US

**Parts Book
Ersatzteile
Lista de Repuestos
Liste de Pièces de Rechange**

www.wackerneuson.com

A nameplate listing the Model Number, Item Number, Revision, and Serial Number is attached to each unit. Please record the information found on this plate so it will be available should the nameplate become lost or damaged. When ordering parts or requesting service information, you will always be asked to specify the model, item number, revision number, and serial number of the unit.

Ein Typenschild mit Typ, Artikelnummer, Version und Maschinen-Nummer ist an jedem Gerät angebracht. Die Daten von diesem Schild bitte notieren, damit sie auch bei Verlust oder Beschädigung des Schildes noch vorhanden sind. Der Typ, die Artikel-Nummer, die Versions- Nummer und die Maschinen-Nummer sind bei der Ersatzteilbestellung oder Nachfragen bezüglich Service-Informationen stets erforderlich.

Una placa de identificación con el modelo, número de referencia, nivel de revisión y número de serie ha sido añadida en cada máquina. Favor de anotar los datos en la placa en caso de que la placa de identificación sea destruida o perdida. En todos los pedidos para repuestos necesita siempre el modelo, el número de referencia, el nivel de revisión y el número de serie de la máquina en cuestión.

Une plaque signalétique mentionnant le modèle, le numéro de référence, le niveau de révision et le numéro de série est fixée sur chaque machine. Veuillez noter les informations relevées sur cette plaque de façon à ce qu'elles soient toujours disponibles si la plaque signalétique venait à être perdue ou endommagée. Lorsque vous commandez des pièces détachées ou vous sollicitez des informations après-vente, on vous demandera toujours de préciser le modèle, le numéro de référence, le niveau de révision et le numéro de série de la machine.

***My machine's numbers are / Die Nummern meines Gerätes sind /
Los números de mi máquina son / Les numéros de ma machine son :***

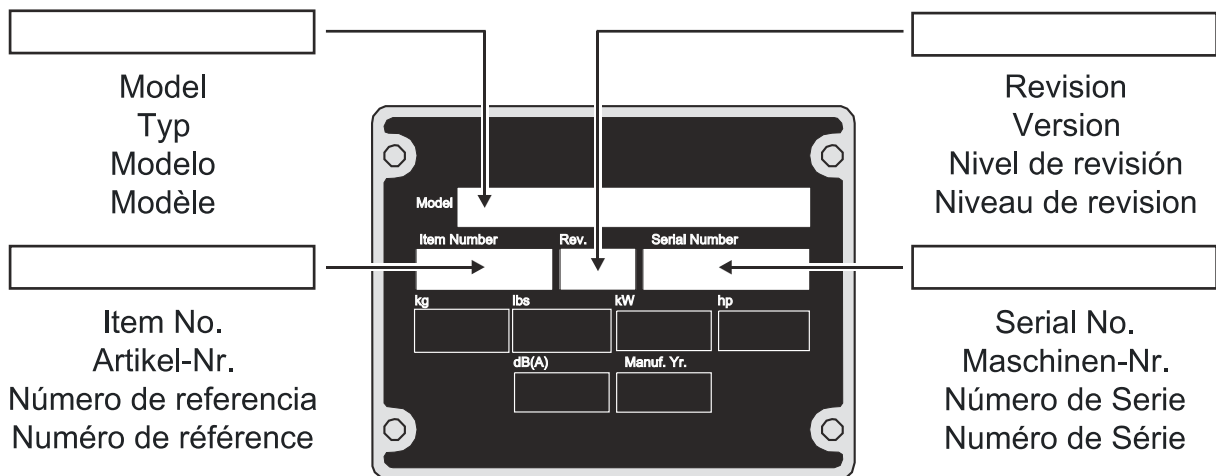

Part Numbers appearing in boldface type are recommended spare parts. This means that these parts are subject to wear under normal operating conditions and may require periodic service or replacement. It is recommended that these items be stocked to meet the expected service requirements of this model. Actual stocking quantities of these and other parts used in more extensive repairs will depend on the service practices of each customer.

Bei den in den Ersatzteillisten fettgedruckten Nummern handelt es sich um empfohlene Ersatzteile. Dies bedeutet, daß diese Teile bei normalen Anwendungsbedingungen natürlicher Abnutzung ausgesetzt sind und gelegentlich ersetzt oder überarbeitet werden müssen. Es wird geraten, diese Teile auf Lager bereit zu haben, um für Service-Arbeiten an diesem Gerät vorbereitet zu sein. Lagerbestände für diese und andere Teile, welche für ausgiebigere Reparaturarbeiten benötigt werden, können je nach Service-Gewohnheiten der einzelnen Kunden variieren.

Los números de partes en negritas en las Listas Ilustradas de Partes son los repuestos recomendados, ésto quiere decir que estas partes se desgastarán bajo circunstancias de funcionamiento normales y pueden requerir servicio periódico o su reemplazo. Se recomienda que el cliente mantenga un abastecimiento adecuado de estas partes para poder satisfacer la demanda requerida por el servicio a la máquina. La cantidad de repuestos que el cliente necesitará para reparaciones dependerá de la póliza de servicio de cada cliente.

Les numéros de pièces imprimés en caractères gras dans les Listes des Pièces Détachées de ce manuel sont les pièces détachées recommandées par la Wacker. Cela veut dire que ces pièces sont sujettes à usure dans des conditions de travail normales et peuvent nécessiter de l'entretien ou leur remplacement. Nous recommandons que vous disposez d'un stock de ces pièces pour pouvoir satisfaire la demande d'entretien de cette machine. Le client doit décider lui-même de la quantité exacte de pièces de rechange qu'il disposera dans ses stocks.

Vibratory Plate cpl. Vibrationsplatte kpl. Plancha Vibradora cpl. Plaque Vibrante cpl.	8
Vibratory Plate cpl. Vibrationsplatte kpl. Plancha Vibradora cpl. Plaque Vibrante cpl.	10
Shackle cpl. Bügel kpl. Estribo cpl. Étrier cpl.	12
Exciter cpl. Erreger kpl. Excitador cpl. Excitateur cpl.	14
Spinkler System cpl. Berieselungsanlage kpl. Systema de Riego cpl. Installation d'Arrosage cpl.	16
Labels Aufkleber Calcomanías Autocollants	18
Engine Motor Motor Moteur	21
Starter Seilzugstarter Arrancador Démarreur	22
Fan hood Gebläseabdeckung Tapa de ventilador Couvercle du sys. de vent.	24
Carburetor Vergaser Carburador Carburateur	26
Air Cleaner Luffilter Filtro del Aire Filtre à Air	30
Muffler Schalldämpfer Silenciador Silencieux	32
Fuel Tank Kraftstofftank Depósito de Combustible Réservoir à Essence	34
Fly wheel Schwungrad Volante Volant	36

Indice**Table des matières**

Cylinder head Zylinderkopf Culata Culasse	38
Ignition coil Zündspule Bobina de encendido Bobine d'allumage	40
Governor Regler Regulador Régulateur	42
Cylinder housing Zylindergehäuse Carcasa de cilindro Carter cylindre	44
Crankcase cover Kurbelgehäuseabdeckung Cubierta da la caja de manivel Couvercle carter de manivelle	46
Crankshaft Kurbelwelle Cigüeñal Vilebrequin	48
Piston Kolben Pistón Piston	50
Camshaft Nockenwelle Arbol de levas Arbre à cames	52
Labels Aufkleber Calcomanias Autocollants	54
Accessories Zubehör Accesorios Accessoires	57
Urethane Pad Kit Gleitvorrichtung Placa de Deslizamiento Jeu de Tapis en Polyuréthane	58
Trolley cpl. Fahrgestell kpl. Dispositivo de Transporte cpl. Chassis cpl.	60
Spinkler System cpl. Berieselungsanlage kpl. Systema de Riego cpl. Installation d'Arrosage cpl.	62
Service Service Servico Service	65

Baseplate Belt guard Kit WP1540
Untermasse Riemenschutz Satz WP1540
Masa inferior Protección de la polea Juego WP1540
Masse inferieure Protection de

66

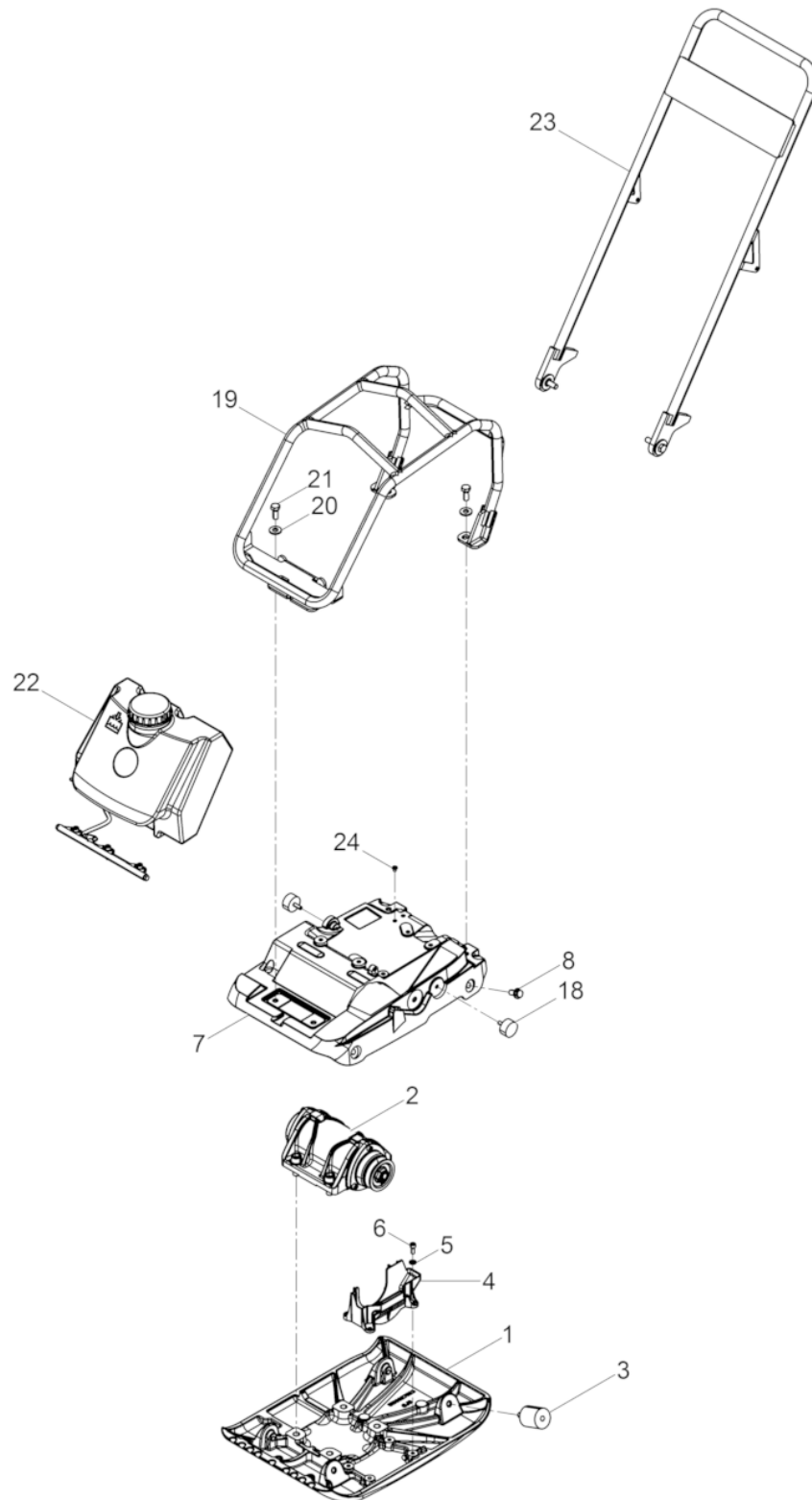

Ref. Pos.	Part No. Artikel Nr.	Qty. St.	Description Beschreibung	Descripción Description	Measurem./Abm.	Norm
					Torque/Drehm.	Sealant Schmierstoff
1	5100027524	1	Baseplate Untermasse	Masa inferior Masse inferieure		
2	5100016322	1	Exciter cpl. Erreger kpl.	Excitador cpl. Excitateur cpl.		
3	5100016316	4	Shockmount Gummi-Metall-Puffer	Tope caucho-metal Tampon metallique oscillant	50x55 40Nm/30ft.lbs	
4	5100018341	1	Belt Guard above Riemenschutz oben	Protección de la Polea Abajo Protection de Courroie Au-dess		
5	0010622	4	Flat washer Scheibe	Arandela Rondelle		
6	0011543	4	Socket head screw Zylinderschraube	Tornillo hueco Vis à six-pans creux	M8 x 20 24Nm/18ft.lbs	ISO4762
7	5100016622	1	Console Konsole	Consola Console		
8	5100018059	4	corrugated-head screw Sicherheitsschraube	tornillo de seguridad vis de sécurité	38Nm/28ft.lbs	
18	5100017108	2	Shockmount Gummi-Metall-Puffer	Tope caucho-metal Tampon metallique oscillant	40x20 11Nm/8ft.lbs	
19	5100016403	1	Protective frame Schutzrahmen	Armazón de protección Cadre protection		
20	0031565	4	Lockwasher Spannscheibe	Arandela elástica Rondelle de ressort	12	DIN6796
21	0011423	4	Hexagonal head cap screw Sechskantschraube	Tornillo hexagonal Vis à tête hexagonale	M12 x 30 86Nm/63ft.lbs	DIN933
22	5100026164	1	Spinkler system cpl. Berieselung kpl.	Systema de riego cpl. Installation d'arrosage cpl.		
23	5100018336	1	Shackle cpl. Bügel kpl.	Estribo cpl. Étrier cpl.		
24	2006531	4	Push-in plug Verschlußstopfen	Tapón Bouchon	0,285in	

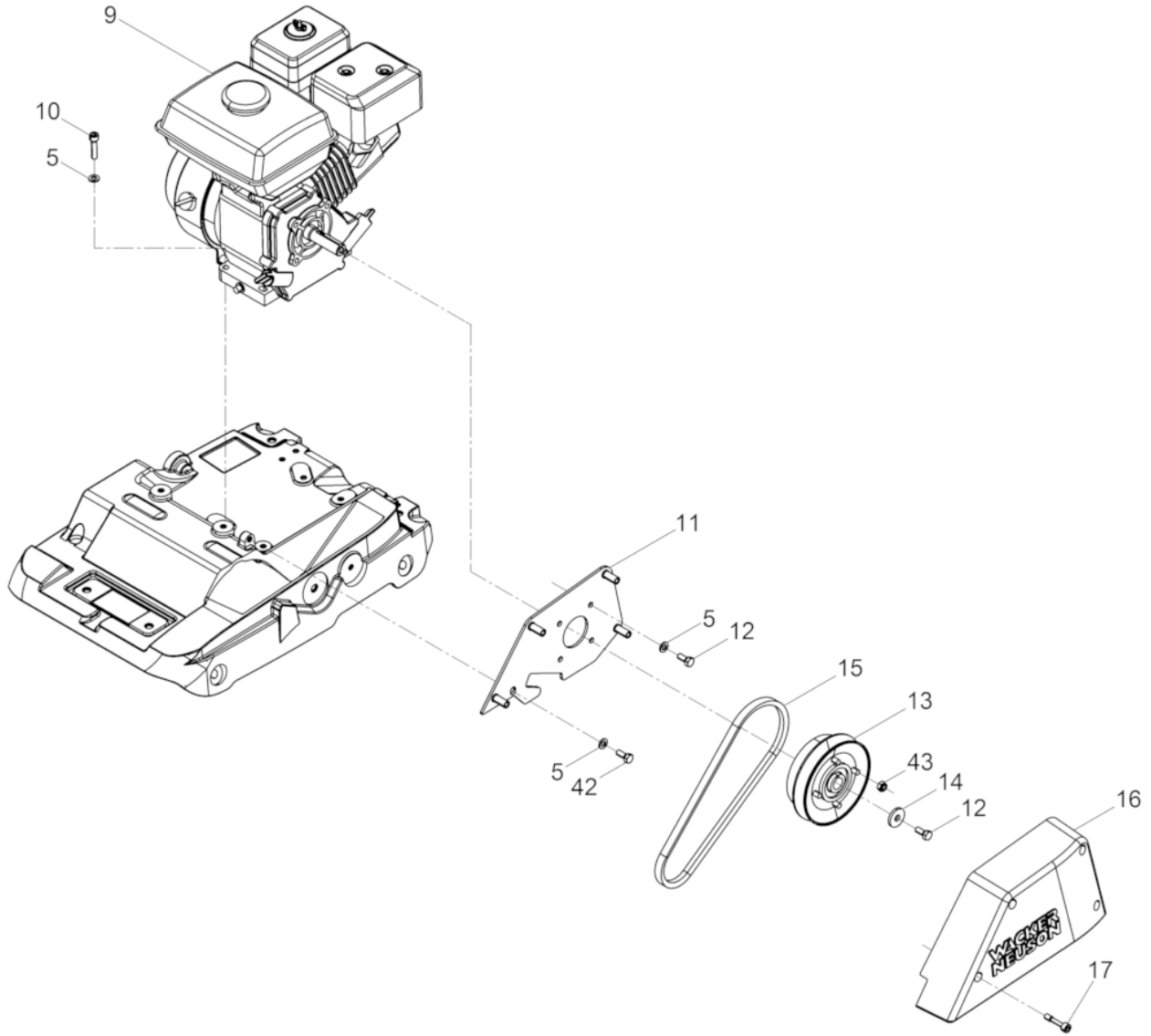

Ref. Pos.	Part No. Artikel Nr.	Qty. St.	Description Beschreibung	Descripción Description	Measurem./Abm.	Norm
					Torque/Drehm.	Sealant Schmierstoff
5	0010622	9	Flat washer Scheibe	Arandela Rondelle		
9	5100018834	1	Gas Engine Benzinmotor	Motor a Gasolina Moteur à Essence		
10	0011539	4	Cheese head screw Zylinderschraube	Tornillo cilíndrico Vis à tête cylindrique	M8 x 40 25Nm/18ft.lbs	ISO4762
11	5100016434	1	V-Belt guard plate Keilriemenschutzblech	Placa de protección Plaque de protection		
12	0026169	5	Hexagonal head cap screw Sechskantschraube	Tornillo hexagonal Vis à tête hexagonale	5/16in-24UNF-2Ak3/4in 18Nm/13ft.lbs	
13	5100016313	1	Centrifugal clutch Fliehkraftkupplung	Embrague centrífugo Embrayage centrifuge		
14	5100016321	1	Washer Scheibe	Arandela Rondelle		
15	5100016461	1	Belt Keilriemen	Correa Courroie		
16	5100025502	1	Belt guard Riemenschutz	Protección de la polea Protection de courroie		
17	0216658	4	Screw Dünnschaftschraube	Tornillo Vis	M 8x 38	
42	0012362	1	Hexagonal head cap screw Sechskantschraube	Tornillo hexagonal Vis à tête hexagonale	25Nm/18ft.lbs	
43	0033356	4	Hexagon nut Sechskantmutter	Tuerca hexagonal Écrou hexagonal		

Shackle cpl.
Bügel kpl.
Estribo cpl.
Étrier cpl.

WP1540Aw US

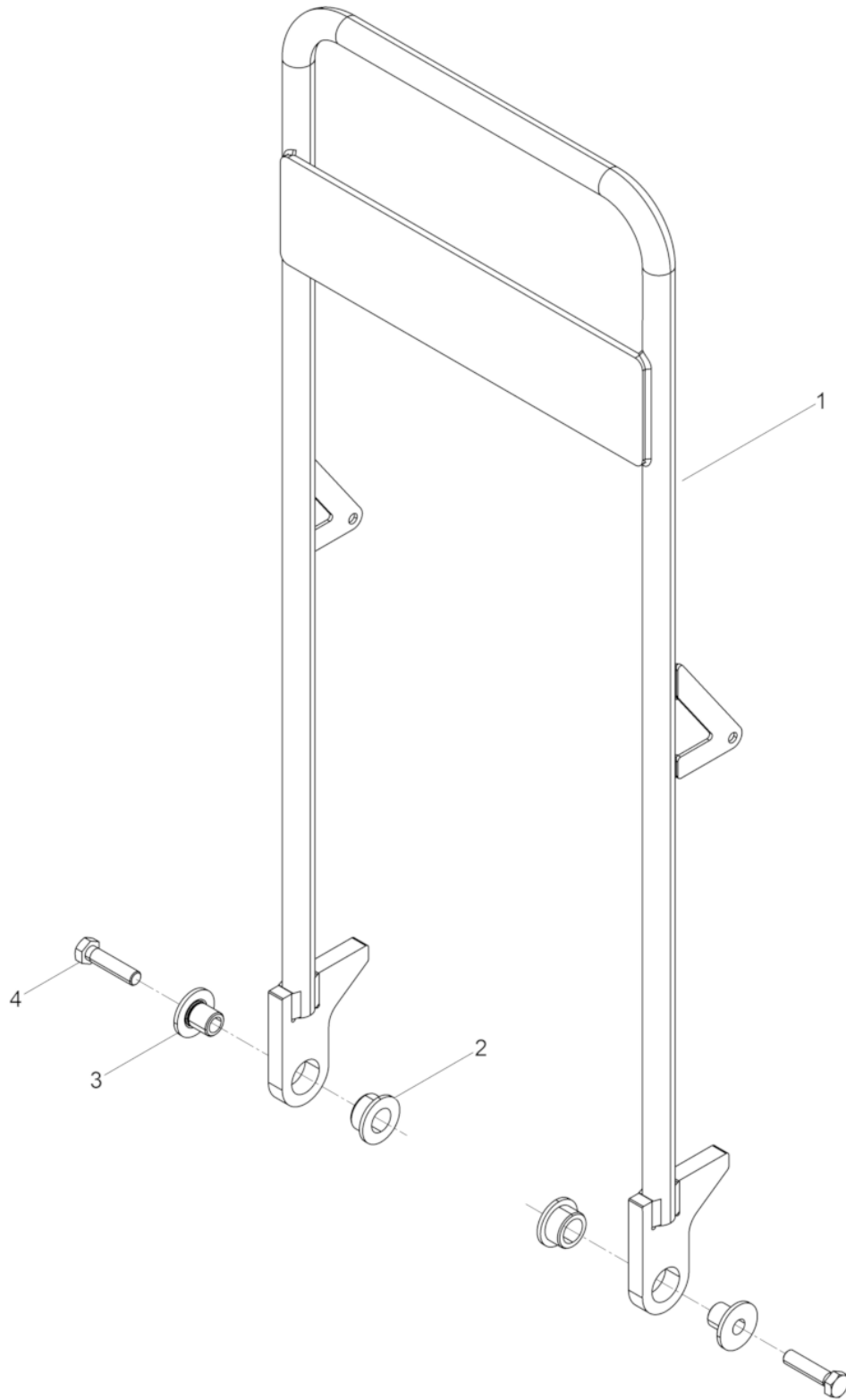

Ref. Pos.	Part No. Artikel Nr.	Qty. St.	Description Beschreibung	Descripción Description	Measurem./Abm.	Norm
					Torque/Drehm.	Sealant Schmierstoff
1	5100018337	1	Shackle Bügel	Estribo Étrier		
2	5100004367	2	Bush Buchse	Buje Boîte		
3	5100018340	2	Bush Buchse	Buje Boîte		
4	0220523	2	Hexagonal head cap screw Sechskantschraube	Tornillo hexagonal Vis à tête hexagonale	M12x 50 120Nm/89ft.lbs	DIN933

Exciter cpl.
Erreger kpl.
Excitador cpl.
Excitateur cpl.

WP1540Aw US

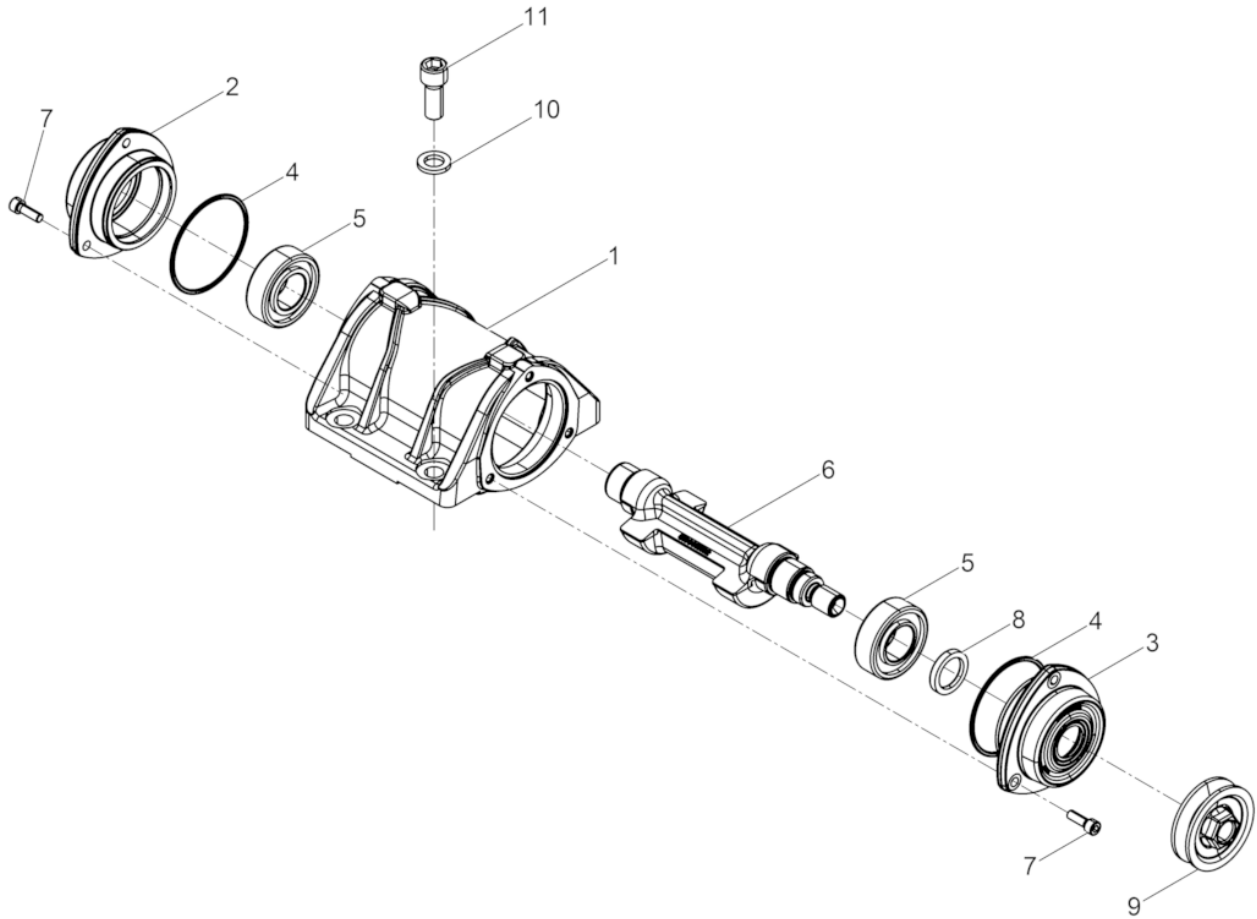

Ref. Pos.	Part No. Artikel Nr.	Qty. St.	Description Beschreibung	Descripción Description	Measurem./Abm.	Norm
					Torque/Drehm.	Sealant Schmierstoff
1	5100016247	1	Exciter housing Erregergehäuse	Carcasa del excitador Carter exciteur		
2	5100022486	1	Bearing bracket Lagerschild	Placa de cojinete Bride palier		
3	5100022485	1	Bearing bracket Lagerschild	Placa de cojinete Bride palier		
4	5100016445	2	O-ring O-Ring	Anillo-O Bague-O	88,49 x 3,53	
5	5100018326	2	Cylindrical roller bearing Zylinderrollenlager	Rodamiento cilíndricos Roulement à rouleaux		
6	5100018133	1	Eccentric shaft Unwuchtwelle	Eje de la masa excéntrica Arbre portant l'excentrique		
7	0011542	6	Cheese head screw Zylinderschraube	Tornillo cilíndrico Vis à tête cylindrique	22Nm/16ft.lbs	
8	5100016446	1	Rotary shaft seal Wellendichtring	Anillo de retén radial Bague d'étanchéité	B 30 x 42 x 7	
9	5100022460	1	V-belt pulley Keilriemenscheibe	Polea en V Poulie à courroie		
10	0010663	4	Flat washer Scheibe	Arandela Rondelle	18	DIN1440
11	0018224	4	Cheese head screw Zylinderschraube	Tornillo cilíndrico Vis à tête cylindrique	M16 x 40 210Nm/155ft.lbs	ISO4762

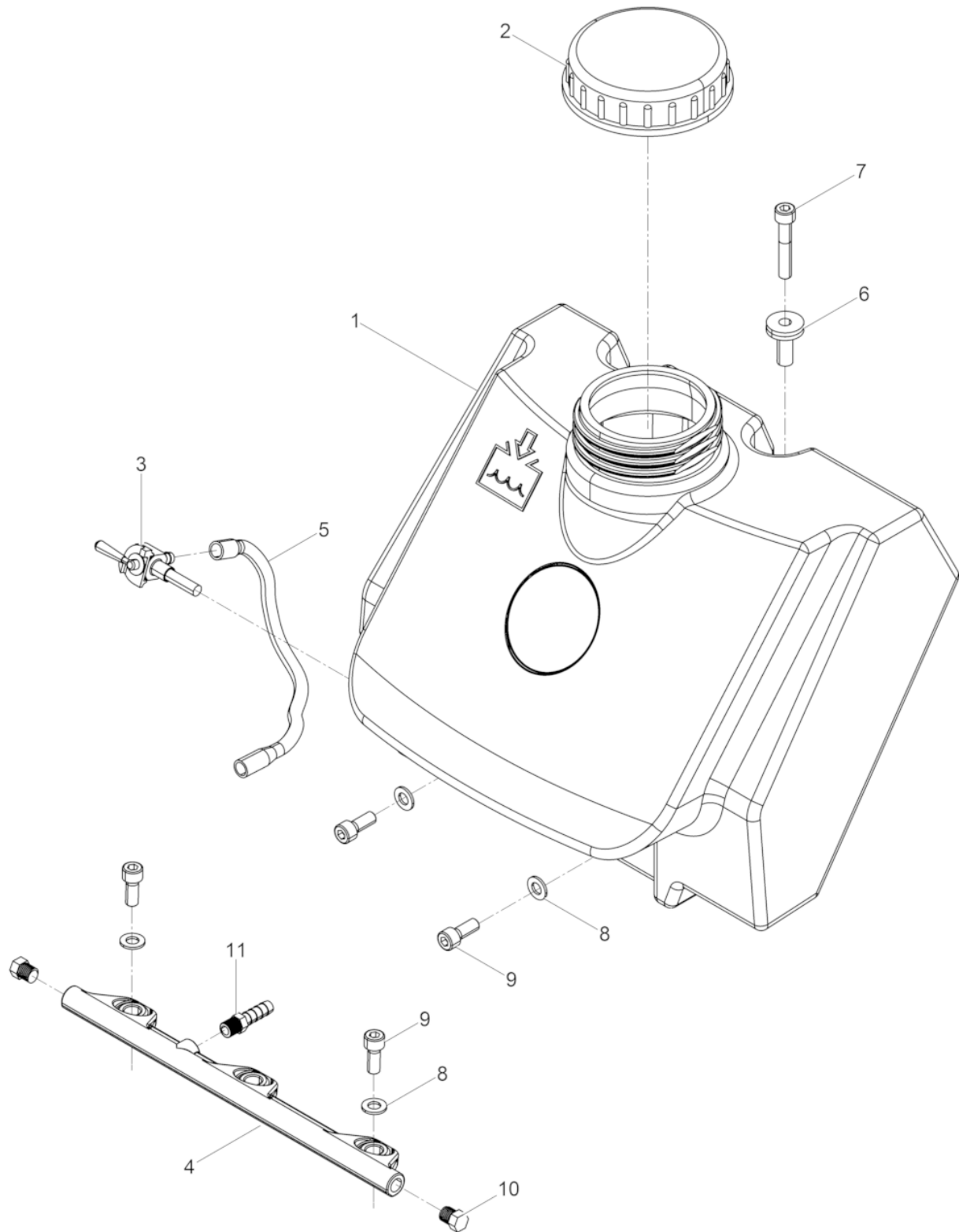

Ref. Pos.	Part No. Artikel Nr.	Qty. St.	Description Beschreibung	Descripción Description	Measurement/Abm.	Norm
					Torque/Drehm.	Sealant Schmierstoff
1	5100016315	1	Water tank Wassertank	Tanque de agua Reservoir à eau		
2	0068351	1	Screwed cover Schraubdeckel	Tapa roscable Couvercle fileté		
3	5100016618	1	Shutoff valve Wasserhahn	Grifo Robinet		
4	5100018335	1	Spinkler System Berieselung	Systema de Riego Installation d'Arrosage		
5	5100018315	1	Water Hose Wasserschlauch	Manguera de agua Tuyau d'eau	6x1,5x266 mm	
6	5100016451	2	Spacer sleeve Distanzhülse	Manguito distanciador Douille d'écartement		
7	0011538	2	Cheese head screw Zylinderschraube	Tornillo cilíndrico Vis à tête cylindrique	M8 x 45 25Nm/18ft.lbs	ISO4762
8	0010622	5	Flat washer Scheibe	Arandela Rondelle		
9	0011543	5	Socket head screw Zylinderschraube	Tornillo hueco Vis à six-pans creux	M8 x 20 24Nm/18ft.lbs	ISO4762
10	5100027000	2	Plug (threaded) Einschraubstopfen	Tapón Bouchon		
11	5100021610	1	Hose fitting Winkeleinschraubstutzen	Atornilladura angulara Manchon visse	No. 6 x 1/8in NPT x 90	
12	5100026164	1	Spinkler system cpl. Berieselung kpl.	Systema de riego cpl. Installation d'arrosage cpl.		

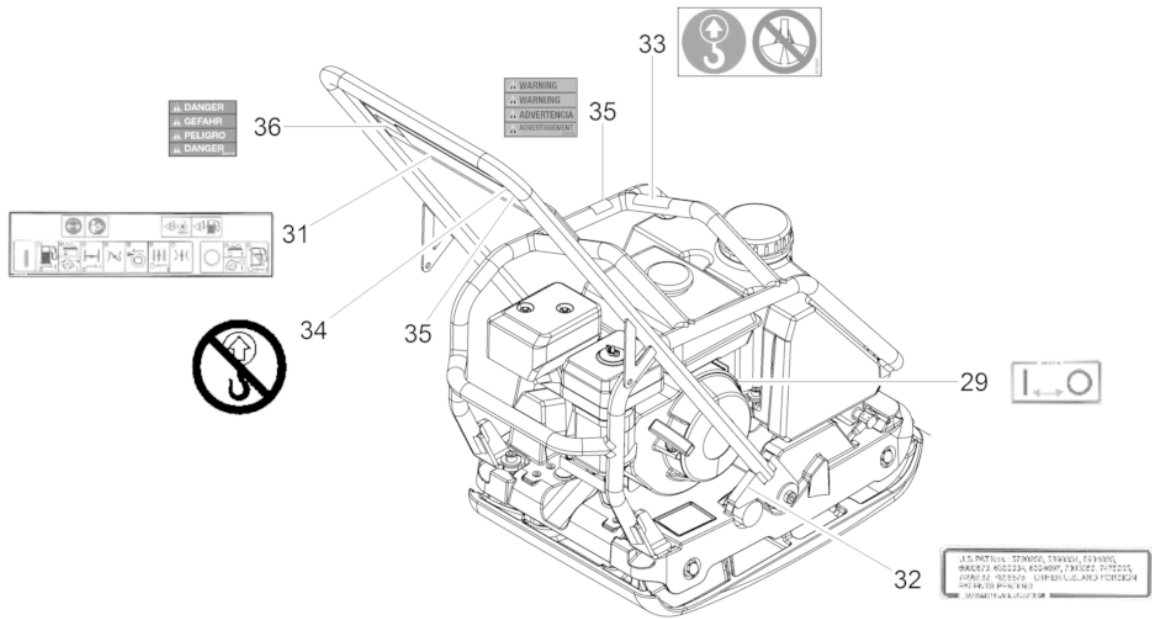
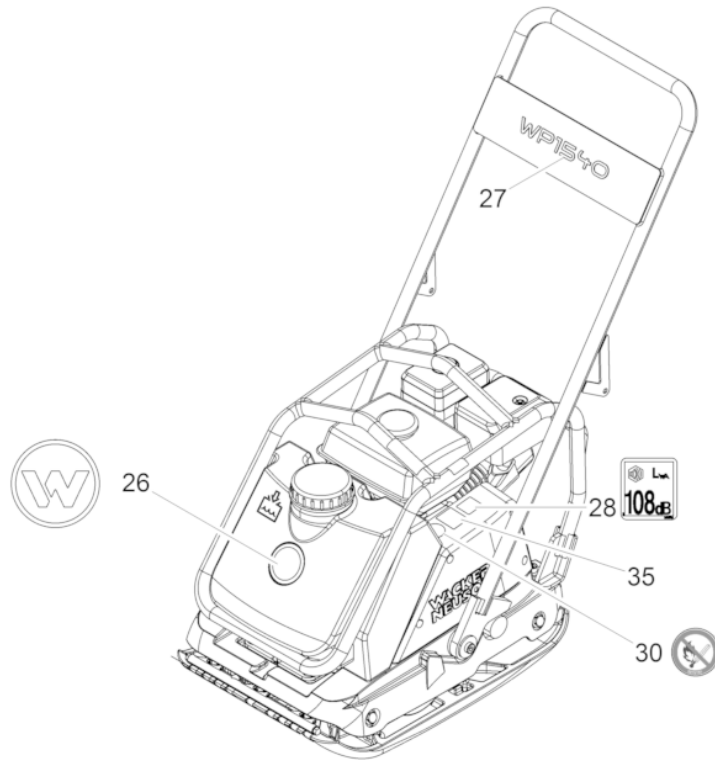

Ref. Pos.	Part No. Artikel Nr.	Qty. St.	Description Beschreibung	Descripción Description	Measurement./Abm.	Norm
					Torque/Drehm.	Sealant Schmierstoff
26	0222085	1	Label Symbol Aufkleber Symbol	Calcomania Símbolo Autocollant Symbole		
27	5100016449	1	Type Label Aufkleber-Typ	Tipo etiqueta autoadhesiva Autocollant de type		
28	0129784	1	Decal-Sound Power Level Aufkleber-Schalleistungspegel	Etiqueta autoadhesiva-nivel de potencia acúëística Autocollante-niveau sonore		
29	5100016455	1	Label (ON-OFF) Aufkleber (ON-OFF)	Calcomania (ON-OFF) Autocollant (ON-OFF)		
30	0219181	1	Labels Aufkleber	Calcomanias Autocollants		
31	5100016619	1	Label Aufkleber	Calcomania Autocollant		
32	5100018423	1	Label Aufkleber	Calcomania Autocollant		
33	0219260	1	Labels Aufkleber	Calcomanias Autocollants		
34	0220000	1	Instruction Label Aufkleber-Warnhinweis	Calcomanía-Indicación Autocollant avec Indication		
35	0219176	3	Labels Aufkleber	Calcomanias Autocollants		
36	0219178	1	Labels Aufkleber	Calcomanias Autocollants		



**WACKER
NEUSON**

**Engine
Motor
Motor
Moteur**

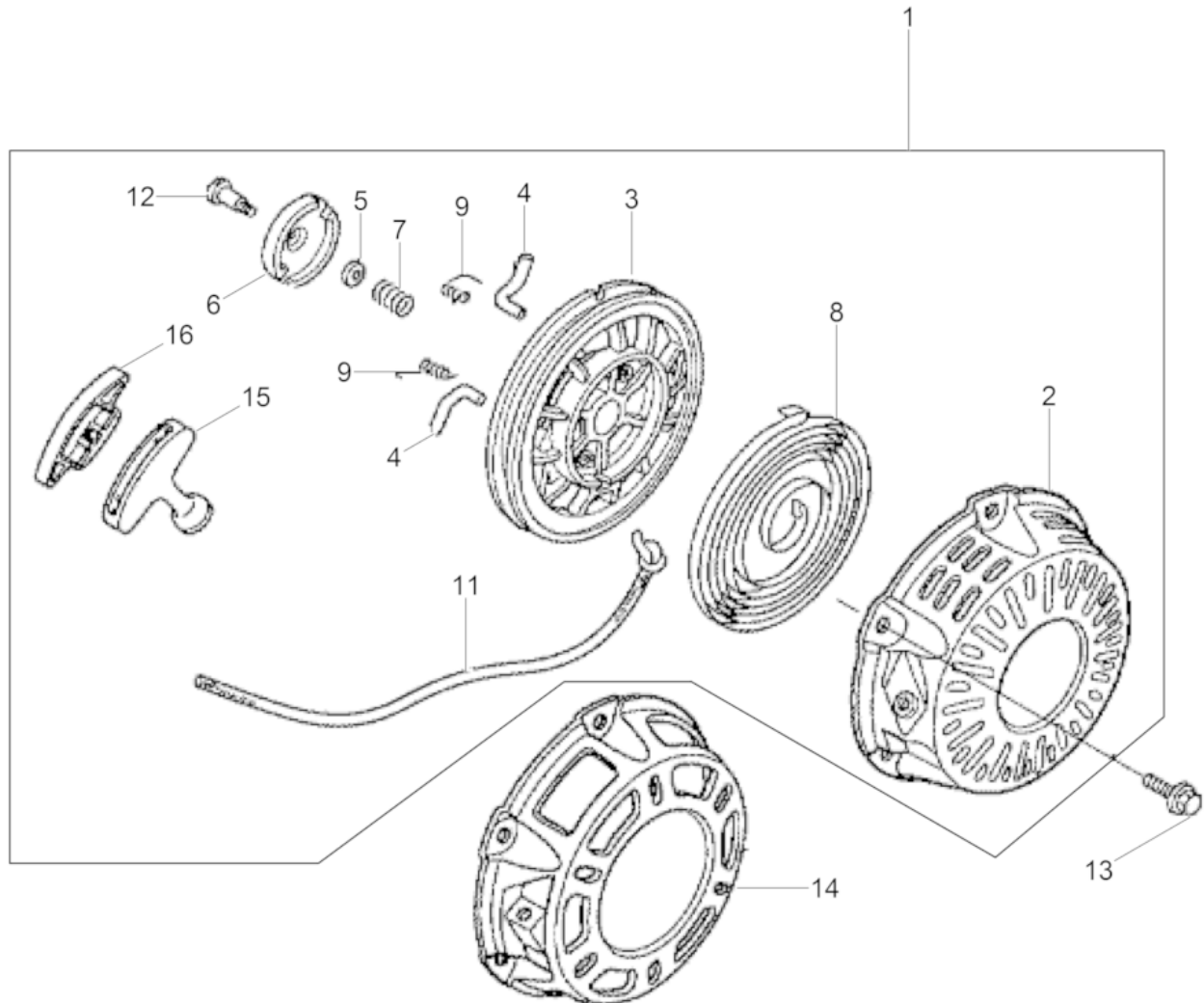

Ref. Pos.	Part No. Artikel Nr.	Qty. St.	Description Beschreibung	Descripción Description	Measurem./Abm.	Norm
					Torque/Drehm.	Sealant Schmierstoff
1	5100005366	1	Starter cpl. (red) Seilzugstarter kpl. (rot)	Arrancador cpl. (rojo) Démarrreur cpl. (rouge)		
1	5100005368	1	Starter cpl. US (red) Seilzugstarter kpl. US (rot)	Arrancador cpl. US (rojo) Démarrreur cpl. US (rouge)		
1	5100005305	1	Starter cpl. US (black) Seilzugstarter kpl. US(schwarz)	Arrancador cpl. US (negro) Démarrreur cpl. US (noir)		
1	5100005367	1	Starter cpl. (black) Seilzugstarter kpl. (schwarz)	Arrancador cpl. (negro) Démarrreur cpl. (noir)		
2	5100005369	1	Housing cpl. (red) Gehäuse kpl. (rot)	Carcasa cpl. (rojo) Enveloppe cpl. (rouge)		
2	5100005307	1	Housing cpl. (black) Gehäuse kpl. (schwarz)	Carcasa cpl. (negro) Carter cpl. (noir)		
3	5100005308	1	Rope disc Seilscheibe	Polea para cuerda Poulie de démarrage		
4	0160527	2	Ratchet Ratsche	Trinquete Cliquet		
5	0160748	1	Friction Plate Reibplatte	Placa de Fricción Plaque à Friction		
6	0160745	1	Guide Führung	Guía Guide		
7	0160747	1	Friction spring Reibfeder	Resorte de Fricción Ressort à Friction		
8	0081777	1	Spring Feder	Resorte Ressort		
9	0207990	2	Spring Schenkelfeder	Resorte Ressort		
11	0081781	1	Rope Starterseil	Cuerda Corde		
12	0207991	1	Screw Schraube	Tornillo Vis		
13	0158458	3	Flange Bolt Flanschbolzen	Tornillo de Perno Vis de Boulon	6 x 10	
15	5100005309	1	Starter handle US Startergriff US	Empuñadura del starter US Poignée du lanceur US		
15	5100005413	1	Starter handle Startergriff	Empuñadura del starter Poignée du lanceur		
16	5100005310	1	Covering Abdeckung	Cubierta Couverture		

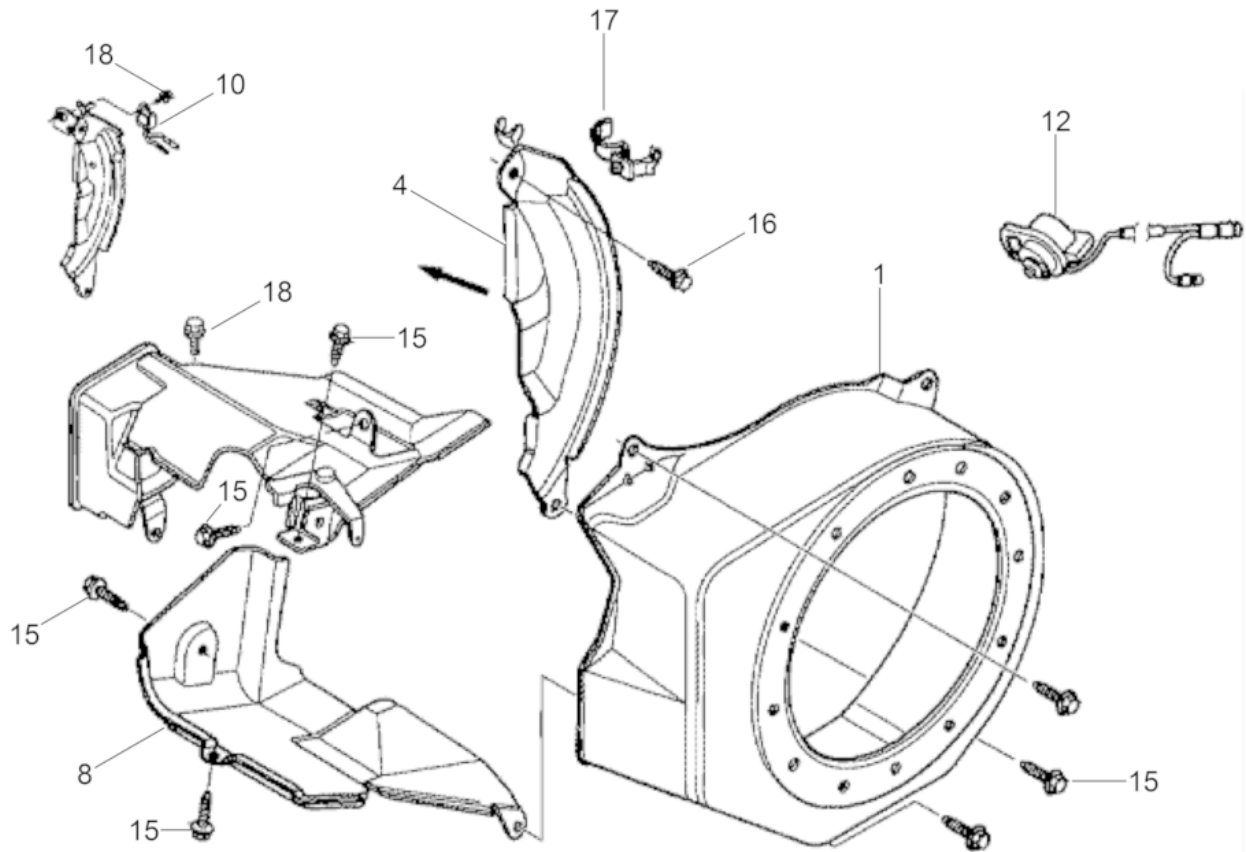

Ref. Pos.	Part No. Artikel Nr.	Qty. St.	Description Beschreibung	Descripción Description	Measurement/Abm.	Norm
					Torque/Drehm.	Sealant Schmierstoff
1	5100005354	1	Fan hood cpl. Gebläseabdeckung kpl.	Tapa de ventilador cpl. Couvercle du sys. de vent. cpl		
1	5100005311	1	Fan hood cpl. (black) Gebläseabdeckung kpl. (schwarz)	Tapa de ventilador cpl. (negro) Couvercle du sys. de vent. cpl		
4	5100005312	1	Covering Abdeckung	Cubierta Couverture		
8	5100005414	1	Bracket cpl. Halterung kpl.	Soporte cpl. Équerre cpl.		
10	5100003471	1	Oil Sensor Ölsensor	Alerta de Aceite Alerte d'Huile		
12	0162682	1	Switch assembly Schalter kpl.	Interruptor compl. Interrupteur compl.		
15	0053990	6	Screw Schraube	Tornillo Vis	M6 x 12 10Nm/7ft.lbs	
16	0071055	1	Screw Schraube	Tornillo Vis	M6 x 20 10Nm/7ft.lbs	
17	0153138	1	Clamp Schelle	Abrazadera Collier		
18	0162077	1	Flange screw Flanschschraube	Tornillo de brida Vis de bride		

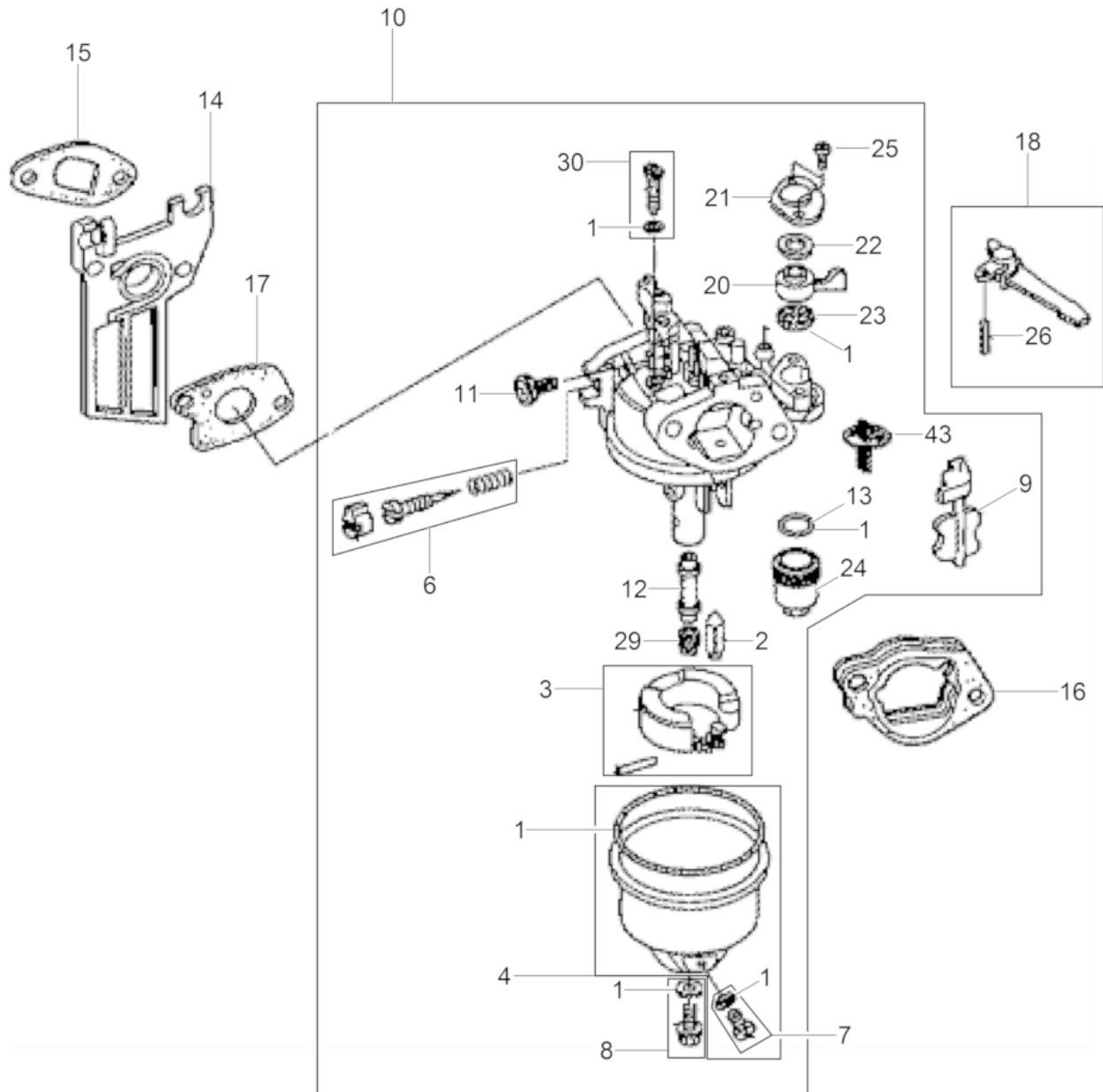

Ref. Pos.	Part No. Artikel Nr.	Qty. St.	Description Beschreibung	Descripción Description	Measurement/Abm.	Norm
					Torque/Drehm.	Sealant Schmierstoff
1	0072781	1	Set-gaskets Dichtungssatz	Juego de juntas Jeu de joints		
2	0071022	1	Set-float valve Schwimmernadel kpl.	Válvula de flotador Pointeau du carburateur		
3	0209764	1	Set-carburetor float Schwimmer kpl.	Juego de flotador Jeu de flotteur		
4	5100005314	1	Float housing Schwimmergehäuse	Cámara de flotador Cuve à niveau constant		
6	0089286	1	Setscrew Gewindestift	Tornillo Vis		
7	5200000430	1	Screw w/washer Schraube mit Scheibe	Tornillo con arandela Vis avec rondelle		
8	5200000431	1	Screw w/washer Schraube mit Scheibe	Tornillo con arandela Vis avec rondelle		
9	5100005415	1	Starter flap Staterklappe	Válvula de mariposa Volet de démarrage		
10	0406637	1	Carburetor cpl. Vergaser kpl.	Carburador compl. Carburateur compl.		
11	0071018	1	Throttle stop screw Anschlagschraube	Tornillo de tope Vis		
12	5100009310	1	Main jet Hauptdüse	Chicler principal Gicleur principal		
13	0125839	1	O-Ring O-Ring	Anillo-O Joint torique		
14	5100005416	1	Isolator Isolator	Aislador Isolateur		
15	0082009	1	Gasket Dichtung	Junta Joint		
16	0071015	1	Spacer Distanzstück	Espaciador Pièce d'écartement		
17	0081762	1	Gasket Dichtung	Junta Joint		
18	0071013	1	Choke control lever Chokehebel	Palanca estranguladora Levier d'étrangleur		
20	0150266	1	Fuel valve lever Kraftstoffhahn	Palanca Levier		
21	0073269	1	Plate Platte	Placa Plaque		
22	0073270	1	Spring washer Federscheibe	Arandela elástica Rondelle à ressort		
23	0073272	1	Gasket Dichtung	Junta Joint		
24	0071023	1	Fuel filter Kraftstofffilter	Filtro de combustible Filtre à carburant		
25	5100005317	2	Screw Kegelkopfschraube 3x6	Tornillo Vis	3x6	
26	0071014	1	Pin Stift	Pasador Goupille	2 x 12	
29	0207672	1	Main jet Hauptdüse	Chicler principal Gicleur principal	62	

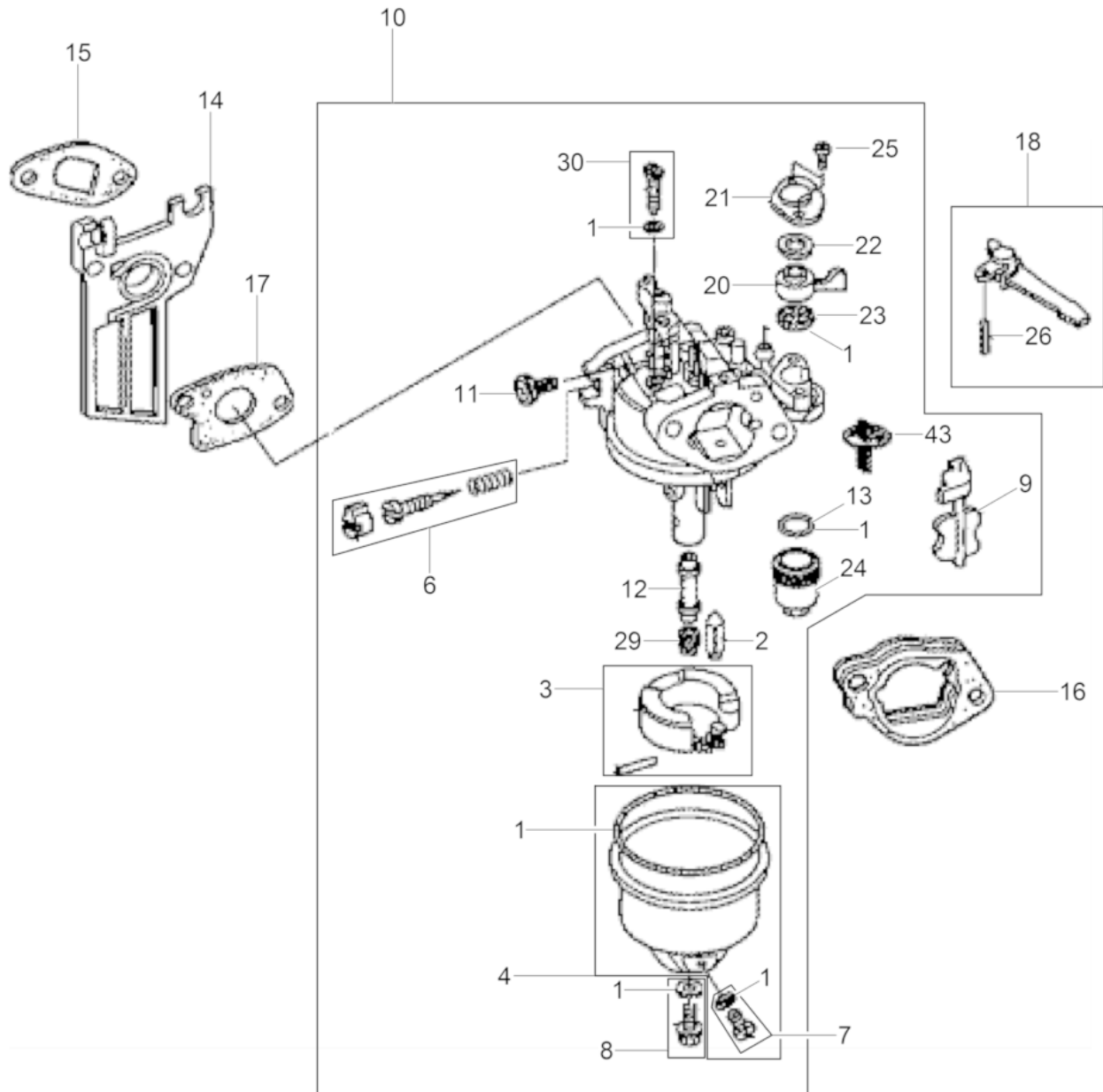

Ref. Pos.	Part No. Artikel Nr.	Qty. St.	Description Beschreibung	Descripción Description	Measurem./Abm.	Norm
					Torque/Drehm.	Sealant Schmierstoff
29	5100005417	1	Main jet Hauptdüse	Chicler principal Gicleur prinzipal	65	
30	0071016	1	Pilot jet Leerlaufdüse	Chicler ralenti Gicleur de ralenti	35	
43	5100000396	1	Filter Filter	Filtro Filtre		

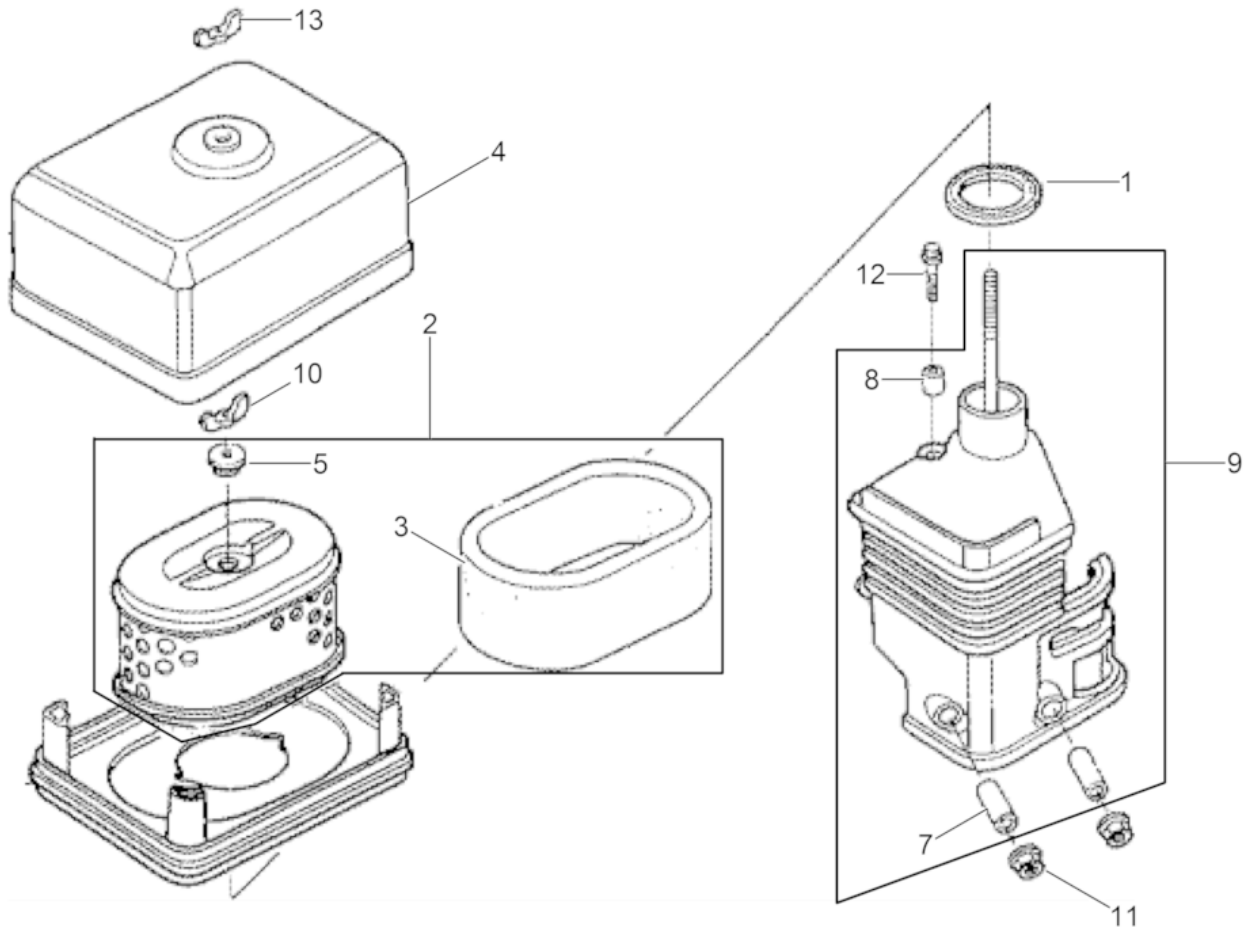

Ref. Pos.	Part No. Artikel Nr.	Qty. St.	Description Beschreibung	Descripción Description	Measurem./Abm.	Norm
					Torque/Drehm.	Sealant Schmierstoff
1	0071032	1	Gasket Dichtung	Junta Joint		
2	5100005319	1	Air cleaner element Luftfiltereinsatz	Elemento-filtro Élément filtrant		
3	0217459	1	Air filter insert Luftfiltereinsatz	Inserto para filtro de aire Garniture filtre à air		
4	5100005419	1	Filter cover Filterdeckel	Tapa de filtro Couvercle du filtre		
4	5100019660	1	Air cleaner cover Luftfilterdeckel	Tapa-filtro del aire Couvercle-filtre à air		
5	0072343	1	Grommet Tülle	Ojal Passe-fil		
7	0081746	2	Sleeve Hülse	Collar Douille		
8	0071035	1	Sleeve Hülse	Manguito Douille		
9	5100005420	1	Filter bracket Filterkonsole	Consola del filtro Console de filtre		
10	0071621	1	Wing nut Flügelmutter	Tuerca mariposa Ecrou papillon	M6	
11	0071056	2	Nut Mutter	Tuerca Ecrou	M6	
12	5100003499	1	Flange screw Flanschschraube 6X20	Tornillo de brida Vis de bride	6x20	
13	5100005421	1	Nut Mutter	Tuerca Ecrou		

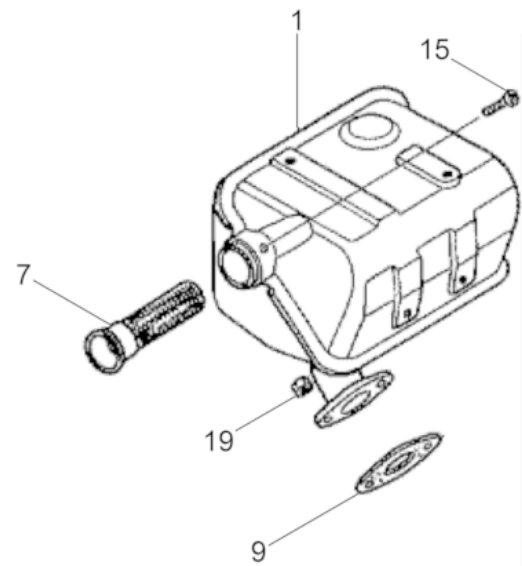
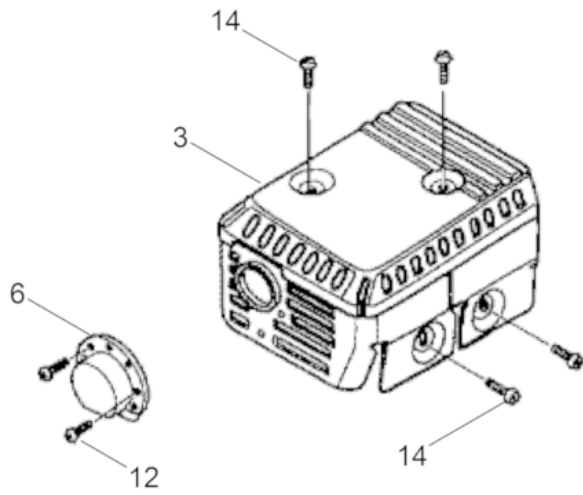

Ref. Pos.	Part No. Artikel Nr.	Qty. St.	Description Beschreibung	Descripción Description	Measurem./Abm.	Norm
					Torque/Drehm.	Sealant Schmierstoff
1	5100005364	1	Muffler cpl. Schalldämpfer kpl.	Silenciador cpl. Silencieux cpl.		
3	5000406646	1	Guard Schutz	Protector Protection		
6	0153130	1	Guide Führung	Guía Guide		
7	0071075	1	Spark arrester Funkenfänger	Parachispas Pare-étincelles		
9	0216516	1	Gasket Dichtung	Junta de estanqueidad Garniture		
12	0209783	2	Self-tapping screw Schneidschraube	Tornillo autorroscante Vis autotaraudeuse	4 x 8	
14	0071070	4	Screw Schraube	Tornillo Vis	M5 x 8	
15	0150916	1	Screw Schraube	Tornillo Vis	M4x6	
19	5100003492	2	Hexagon nut Sechskantmutter M8	Tuerca hexagonal Écrou hexagonal	M8	

Fuel Tank
Kraftstofftank
Depósito de Combustible
Réservoir à Essence

WP1540Aw US

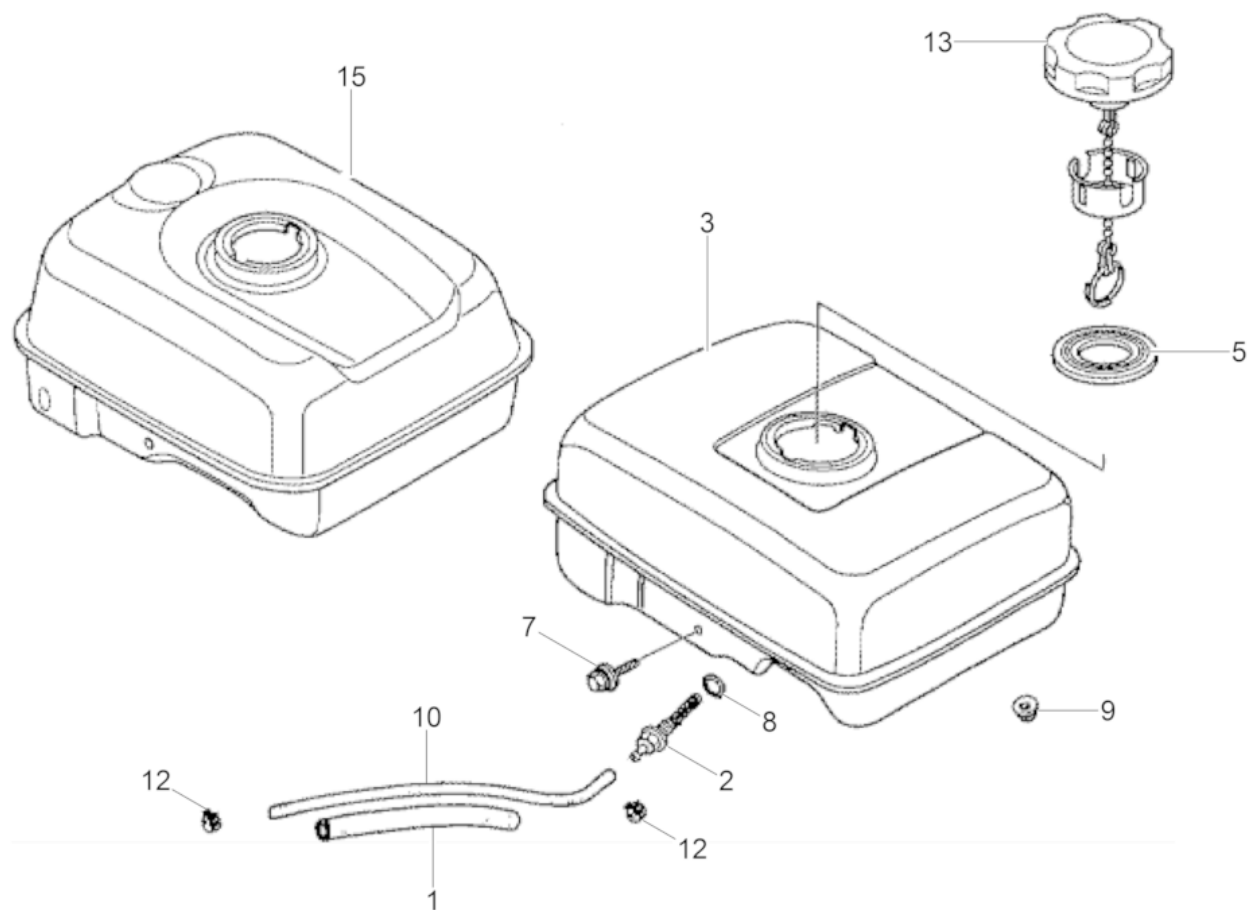

Ref. Pos.	Part No. Artikel Nr.	Qty. St.	Description Beschreibung	Descripción Description	Measurement/Abm.	Norm
					Torque/Drehm.	Sealant Schmierstoff
1	0081764	1	Protective hose Schlauchstück	Manguera Tuyau		
2	5100000395	1	Connection Verbindungsstück	Conexión Connexion		
3	0082013	1	Fuel tank Kraftstofftank	Tanque de combustible Réservoir de carburant		
3	0110765	1	Fuel Tank Kraftstofftank	Depósito de Combustible Réservoir à Essence		
5	0209770	1	Gasket Dichtung	Junta de estanqueidad Garniture		
7	0209771	1	Flange Bolt Flanschbolzen	Tornillo de Perno Vis de Boulon	6x29	
8	0208616	1	O-Ring O-Ring	Anillo-O Joint torique	14M	
9	0071056	2	Nut Mutter	Tuerca Ecrou	M6	
10	5100005325	1	Fuel hose Kraftstoffschlauch 4,5x145	Manguera de combustible Tuyau à essence	4,5x145	
12	0208617	2	Clamp Rohrschelle	Abrazadera Agrafe		
13	0213409	1	Flywheel Schwungrad	Volante Volant		
13	5100005357	1	Tank cover cpl. Tankdeckel kpl.	Tapa de tanque cpl. Couvercle du reservoir cpl.		
15	5100005323	1	Fuel Tank cpl. Kraftstofftank kpl.	Tanque de Combustible cpl. Réservoir de Carburant cpl.		

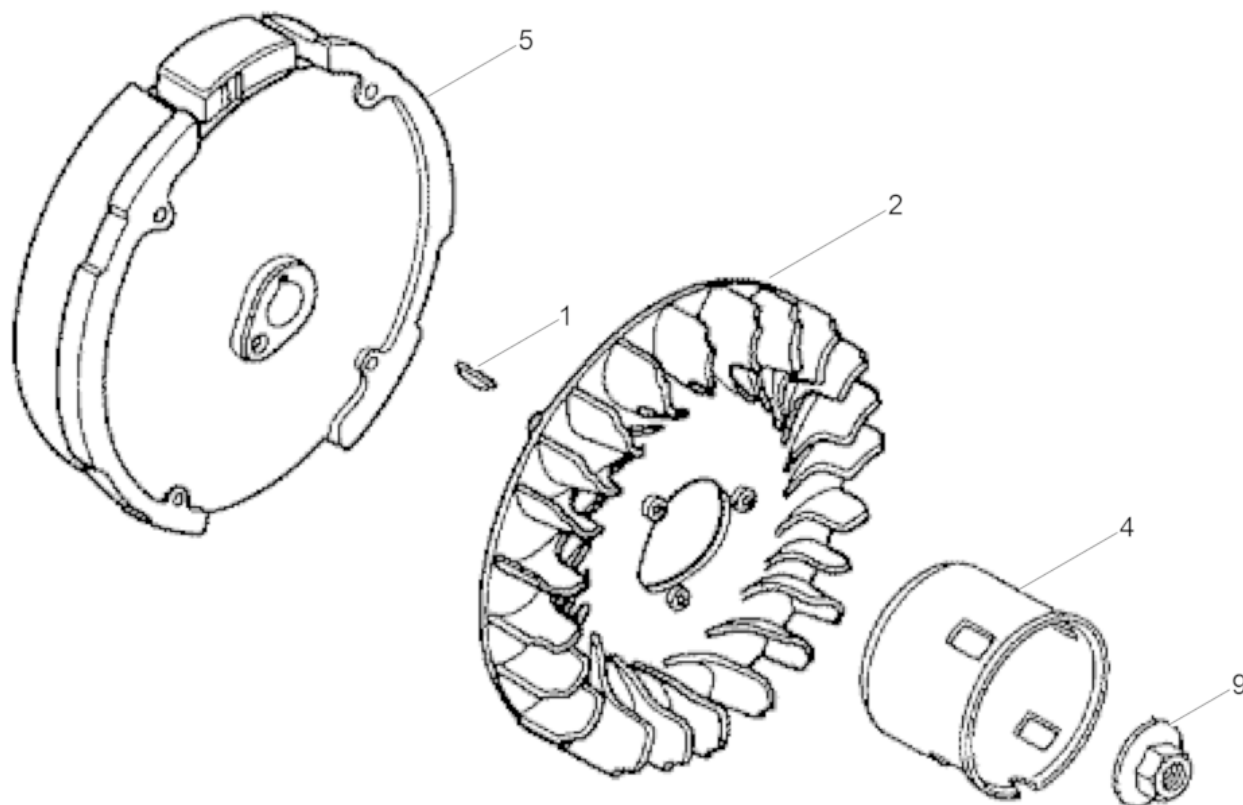

Ref. Pos.	Part No. Artikel Nr.	Qty. St.	Description Beschreibung	Descripción Description	Measurem./Abm.	Norm
					Torque/Drehm.	Sealant Schmierstoff
1	0068967	1	Woodruff key Keil	Chaveta Woodruff Clavette Woodruff	25 x 18	
2	0071652	1	Fan Lüfterrad	Ventilador Ventilateur		
4	0210396	1	Pulley Seilscheibe	Polea Poulie		
5	5100005422	1	Fly wheel cpl. Schwungrad kpl.	Volante cpl. Volant cpl.		
9	0162686	1	Nut Mutter	Tuerca Écrou	M14	

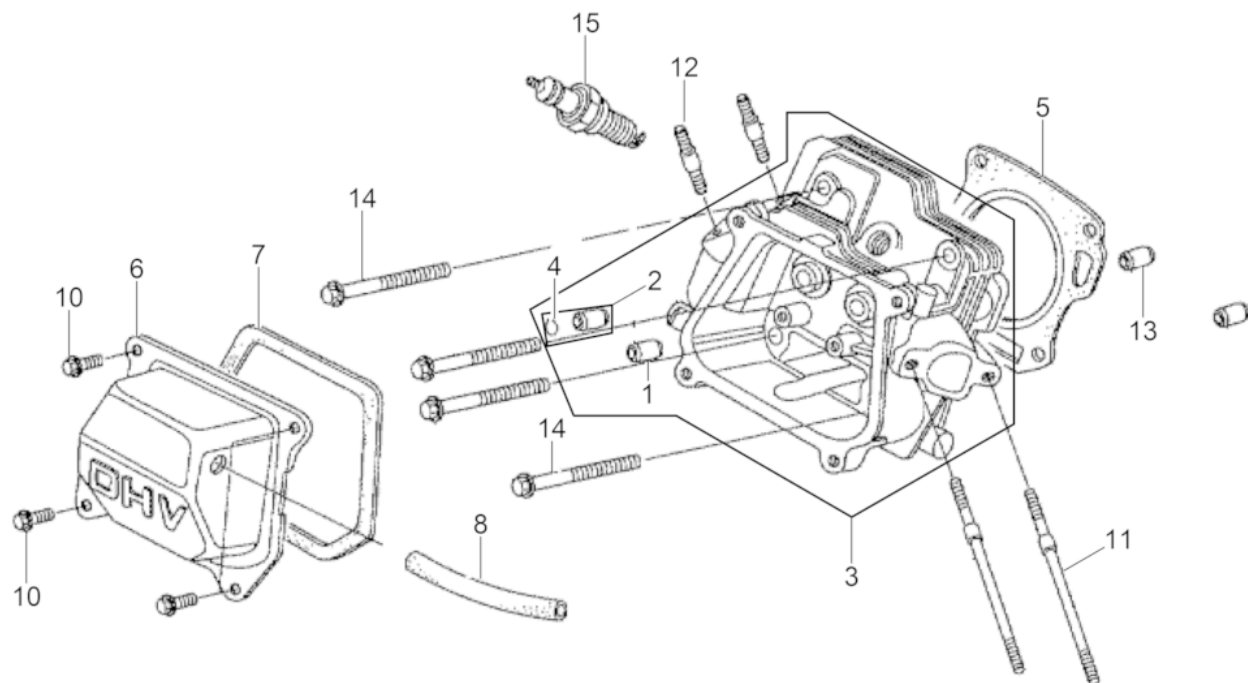

Ref. Pos.	Part No. Artikel Nr.	Qty. St.	Description Beschreibung	Descripción Description	Measurement./Abm.	Norm
					Torque/Drehm.	Sealant Schmierstoff
1	0070945	1	Valve guide Ventilführung	Guía de válvula Guide de soupape		
2	0070944	1	Valve guide Ventilführung	Guía de válvula Guide de soupape		
3	5100005423	1	Cylinder Head cpl. Zylinderkopf kpl.	Culata cpl. Culasse cpl.		
4	0081744	1	Retaining ring Sicherungsring	Anillo de retención Bague d'arrêt		
5	5100005329	1	Cylinder head gasket Zylinderkopfdichtung	Junta de culata del cilindro Joint de culasse de cylindre		
6	5100005424	1	Cover cpl. Deckel kpl.	Tapa cpl. Couvercle cpl.		
7	0070942	1	Gasket Dichtung	Junta Joint		
8	0081761	1	Breather tube Entlüftungsrohr	Tubo respiradero Tube reniflard		
10	0053990	4	Screw Schraube	Tornillo Vis	M6 x 12 10Nm/7ft.lbs	
11	0073263	2	Stud Gewindebolzen	Perno prisionero Boulon	M6 x 109	
12	0070948	2	Stud Gewindebolzen	Perno prisionero Boulon	M8 x 32	
13	0070950	2	Dowel pin Passstift	Espiga Cheville		
14	0213398	4	Flange screw Flanschschraube	Tornillo de brida Vis de bride	M 8x60	
15	0150914	1	Spark plug Zündkerze	Bujía Bougie		

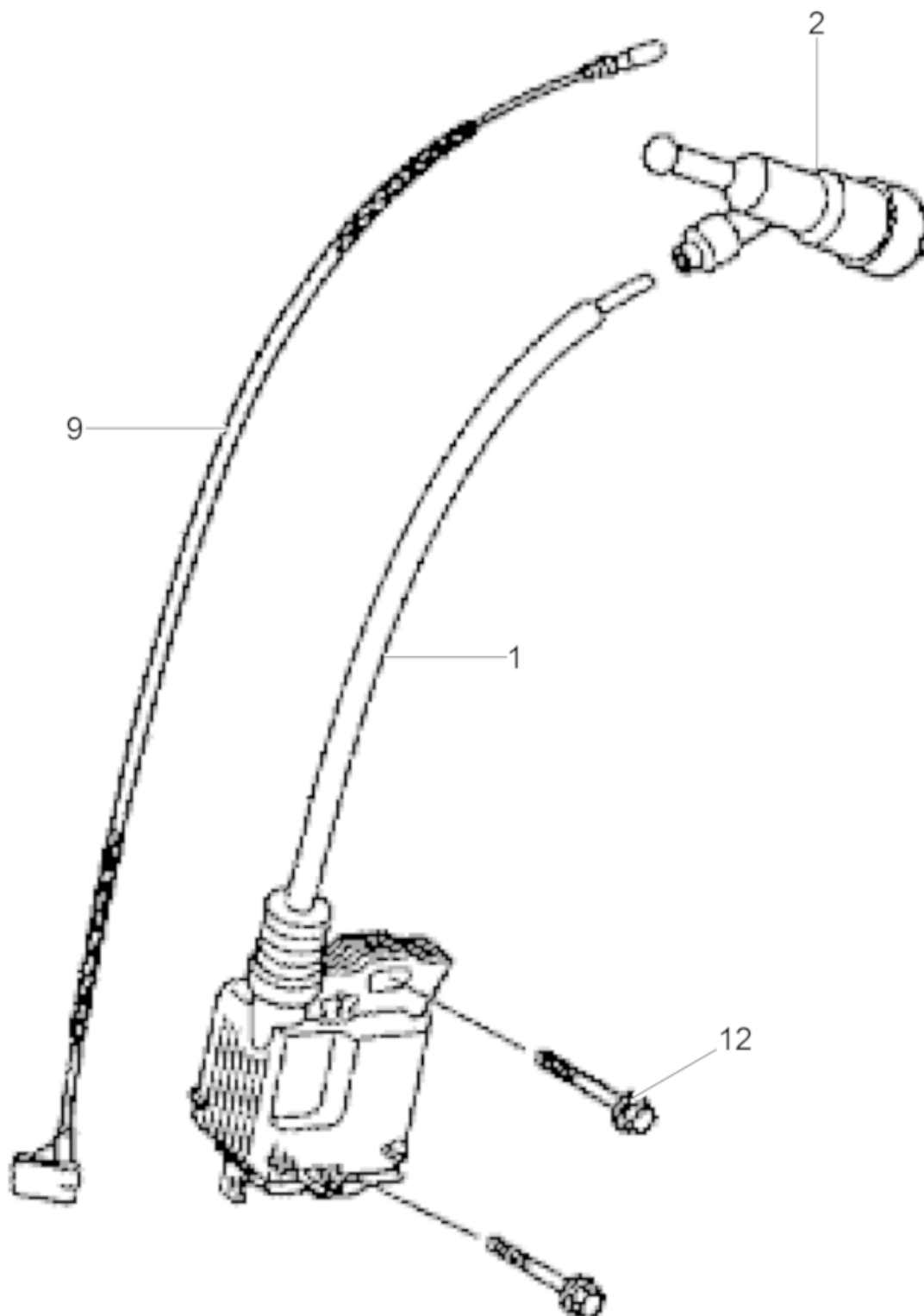

Ref. Pos.	Part No. Artikel Nr.	Qty. St.	Description Beschreibung	Descripción Description	Measurement/Abm.	Norm
					Torque/Drehm.	Sealant Schmierstoff
1	5100003455	1	Ignition Coil cpl. Zündspule kpl.	Bobina de Encendido cpl. Bobine d'Allumage cpl.		
2	0162680	1	Spark plug terminal cap Zündkerzenstecker	Enchufe de bujía Porte bougies		
9	0081663	1	Short circuit cable Kurzschlusskabel	Cable de cortocircuito Câble courti-circuit		
12	0081737	2	Screw Schraube	Tornillo Vis	M6 x 25	

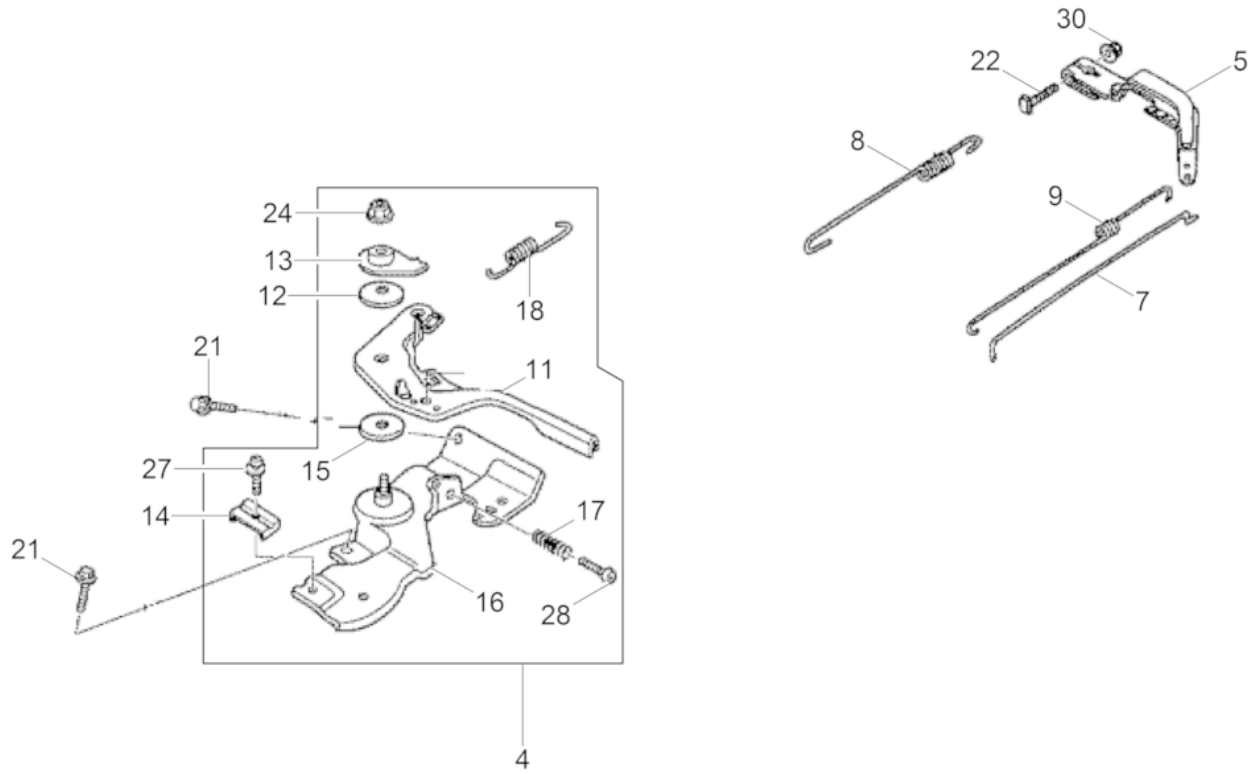

Ref. Pos.	Part No. Artikel Nr.	Qty. St.	Description Beschreibung	Descripción Description	Measurement/Abm.	Norm
					Torque/Drehm.	Sealant Schmierstoff
4	5100009311	1	Governor cpl. US Regler kpl. US	Regulador cpl. US Régulateur cpl. US		
4	5100009312	1	Governor cpl. Regler kpl.	Regulador cpl. Régulateur cpl.		
5	5100005425	1	Governor lever Regulierhebel	Palanca reguladora Levier régulateur		
7	5100005332	1	Governor rod Reglerstange	Varillaje de regulación Tige de régulateur		
8	0406658	1	Governor spring Reglerfeder	Resorte del regulador Ressort régulateur		
9	5100005427	1	Return spring Rückholfeder	Resorte de retorno Ressort de rappel		
11	5100005333	1	Governor lever Reglerhebel	Palanca de regulador Levier régulateur		
12	0071058	1	Spring Feder	Resorte Ressort		
13	0071057	1	Washer Scheibe	Arandela Rondelle		
14	0071062	1	Cable holder Klemme	Soporte cable Attache		
15	0071064	1	Spacer Distanzstück	Espaciador Pièce d'écartement		
16	5100005363	1	Bracket cpl. Halterung kpl.	Soporte cpl. Équerre cpl.		
17	0054088	1	Adjusting spring Feder	Resorte de ajuste Ressort d'ajustage		
18	0071667	1	Spring Feder	Resorte Ressort		
21	0053990	2	Screw Schraube	Tornillo Vis	M6 x 12 10Nm/7ft.lbs	
22	0068966	1	Screw Schraube	Tornillo Vis		
24	0072782	1	Locknut Sicherungsmutter	Contratuerca Contre-écrou	M6	
27	0110112	1	Screw Schraube	Tornillo Vis	5 x 16	
28	0081990	1	Screw Schraube	Tornillo Vis	M5 x 25	
30	0071056	1	Nut Mutter	Tuerca Ecrou	M6	

Cylinder housing
Zylindergehäuse
Carcasa de cilindro
Carter cylindre

WP1540Aw US

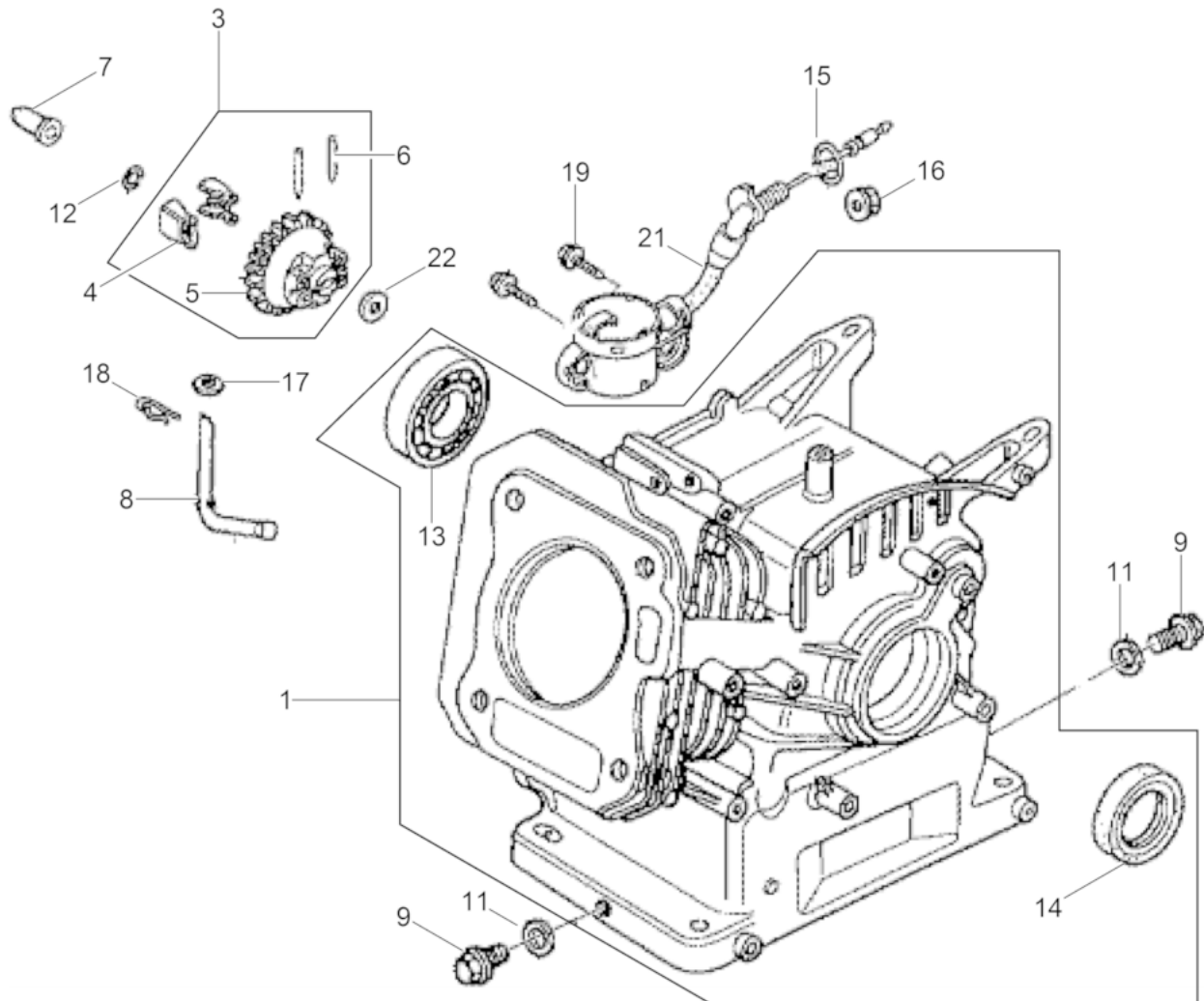

Ref. Pos.	Part No. Artikel Nr.	Qty. St.	Description Beschreibung	Descripción Description	Measurem./Abm.	Norm
					Torque/Drehm.	Sealant Schmierstoff
1	5200006492	1	Cylinder cpl. Zylinder kpl.	Cilindro compl. Cylindre compl.		
3	5100005429	1	Governor cpl. Regler kpl.	Regulador cpl. Régulateur cpl.		
4	5100005430	2	Weight Gewicht	Peso Poids		
5	5100005431	1	Bracket Halter	Soporte Équerre		
6	0156689	2	Pin Stift	Espiga Goupille		
7	5100005432	1	Governor Pin Reglerstift	Pasador Del Regulador Pointe De Regulateur		
8	5100005433	1	Governor Regler	Regulador Régulateur		
9	0070964	2	Plug (threaded) Verschlußschraube	Tapón roscado Bouchon		
11	0070963	2	Washer Scheibe	Arandela Rondelle		
12	0081615	1	Retaining ring Sicherungsring	Anillo de retención Bague d'arrêt		
13	0082018	1	Bearing Lager	Rodamiento Roulement		
14	0217464	1	Oil seal Wellendichtring	Empaque de aceite Joint d'huile	25x41x6	
15	0208616	1	O-Ring O-Ring	Anillo-O Joint torique	14M	
16	0072332	1	Flange nut Flanschmutter	Tuerca de reborde Ecrou de bride	M10	
17	0071639	1	Washer Scheibe	Arandela Rondelle	6M	
18	0054033	1	Pin Stift	Pasador Goupille		
19	5100003498	2	Flange screw Flanschschraube 6X12	Tornillo de brida Vis de bride	6x12	
21	0216513	1	Oil alert switch cpl. Ölwarnschalter	Modulo-interruptor Module-contacteur		
22	0071639	1	Washer Scheibe	Arandela Rondelle	6M	

Crankcase cover
Kurbelgehäuseabdeckung

WP1540Aw US

Cubierta da la caja de manivel
Couvercle carter de manivelle

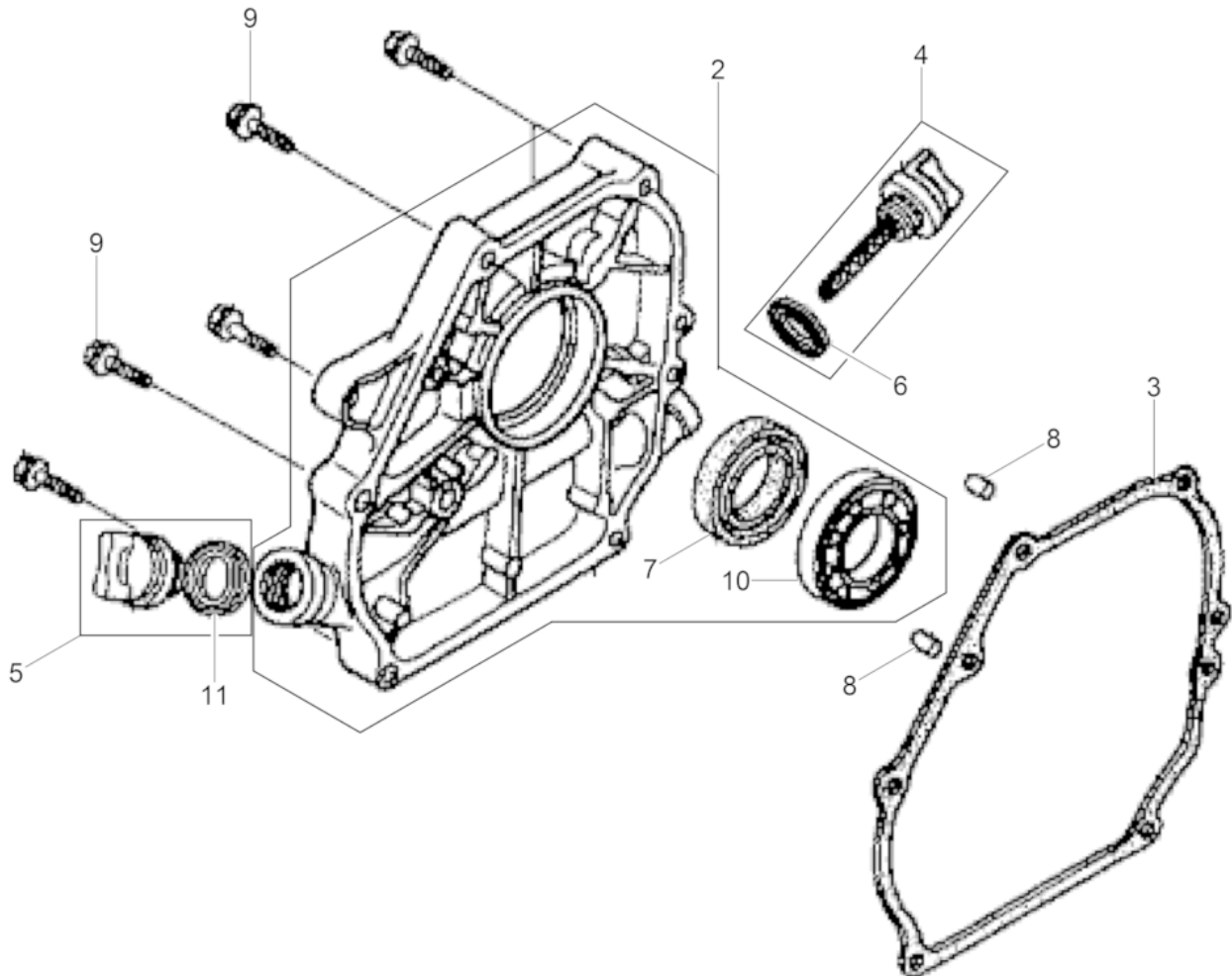

Ref. Pos.	Part No. Artikel Nr.	Qty. St.	Description Beschreibung	Descripción Description	Measurem./Abm.	Norm
					Torque/Drehm.	Sealant Schmierstoff
2	5100005434	1	Crankcase Cover cpl. Kurbelgehäusedeckel kpl.	Tapa del Carter cpl. Couvercle de Carter cpl.		
3	5100009314	1	Gasket Dichtung	Junta Joint		
4	0162645	1	Dipstick assembly Peilstab kpl.	Indicador del nivel de aceite compl. Réglette-jauge compl.		
5	0162646	1	Oil filler cap Kappe-Ölfüller	Llenador de aceite Remplisseur d'huile		
6	0162647	1	Gasket Dichtung	Junta de estanqueidad Garniture		
7	0053983	1	Shaft seal Wellendichtring	Sello del eje Bague d'étanchéité		
8	0053995	2	Dowel pin Passstift	Espiga Cheville	A8 x 14	
9	5100003504	6	Flange screw Flanschschraube 8X32	Tornillo de brida Vis de bride	8x32	
10	5100003510	1	Grooved ball bearing Radialkugellager 6205	Rodamiento de bolas Roulement à billes		
11	0162647	1	Gasket Dichtung	Junta de estanqueidad Garniture		

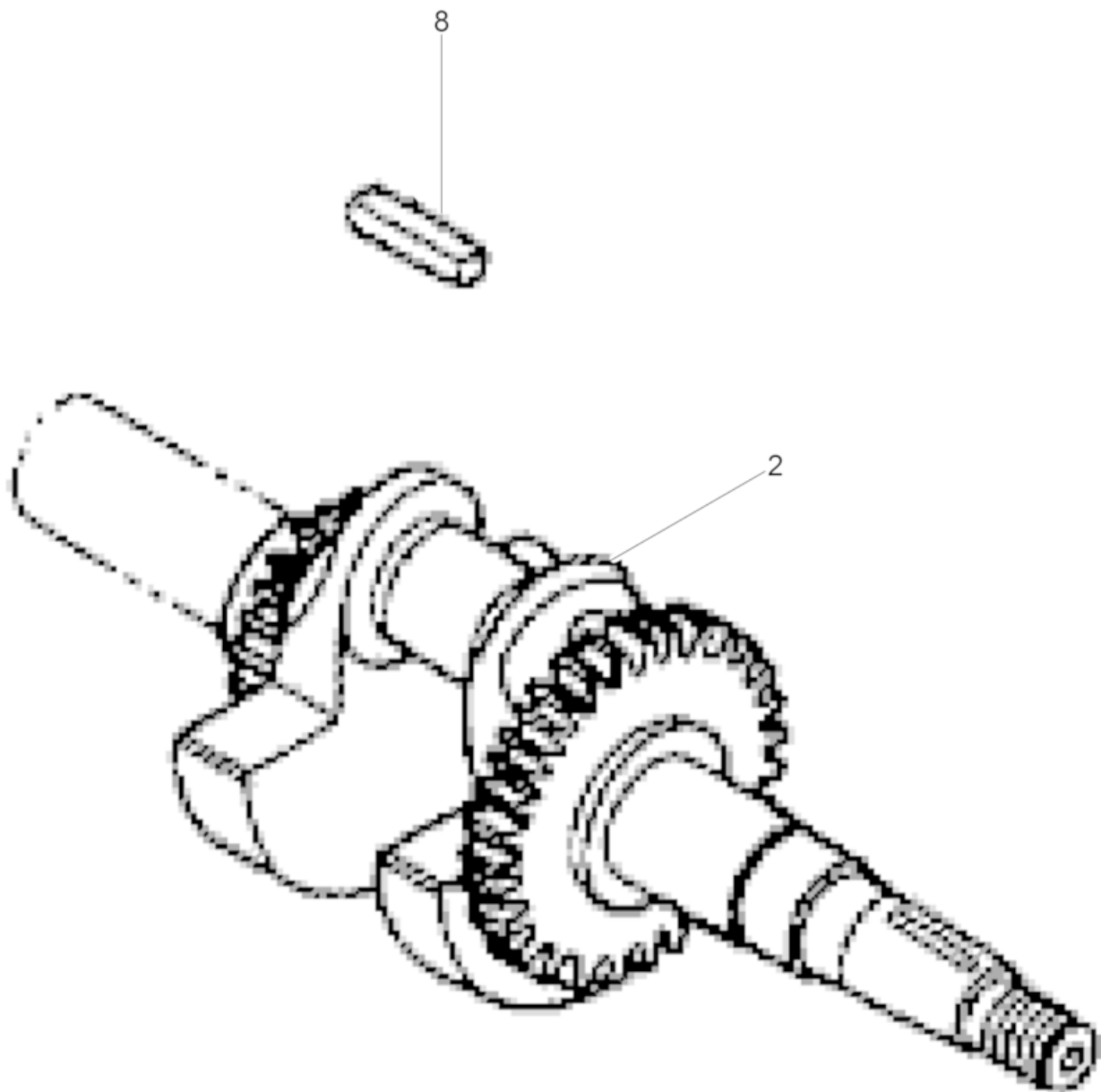

Ref. Pos.	Part No. Artikel Nr.	Qty. St.	Description Beschreibung	Descripción Description	Measurement./Abm.	Norm
					Torque/Drehm.	Sealant Schmierstoff
2	5100005359	1	Crankshaft cpl. Kurbelwelle kpl.	Cigüeñal cpl. Vilebrequin cpl.		
2	5000217529	1	Ball bearing Radialkugellager	Rodamiento a bolas Roulement à billes		
2	5100003485	1	Grooved ball bearing Radialkugellager 6205	Rodamiento de bolas Roulement à billes		
8	0070999	1	Fitting key Passfeder	Chaveta Clavette	4,78 x 38	

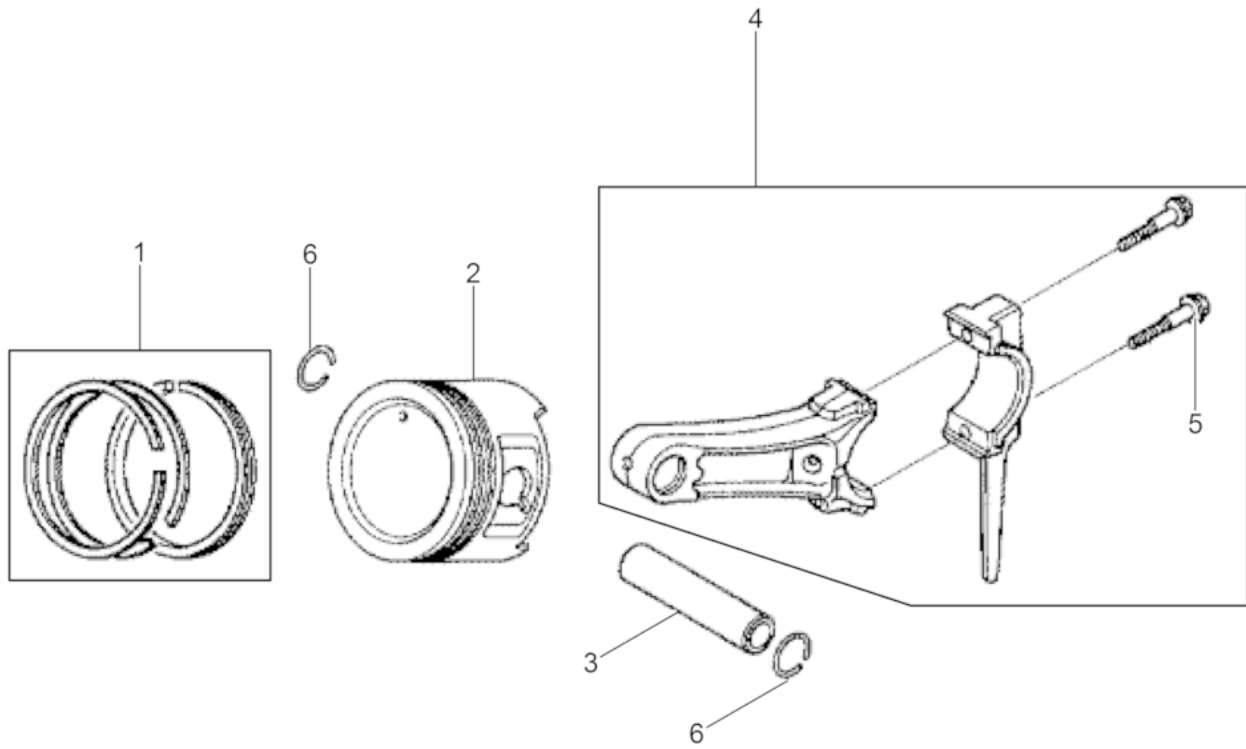

Ref. Pos.	Part No. Artikel Nr.	Qty. St.	Description Beschreibung	Descripción Description	Measurement./Abm.	Norm
					Torque/Drehm.	Sealant Schmierstoff
1	5100005355	1	Set of piston rings Kolbenringsatz	Juego de aros de pistón Jeu de bagues de piston		
1	0213334	1	Piston Ring Set Kolbenringsatz	Juego de anillos Jeu de segments	+0,25 mm	
1	0213335	1	Piston Ring Set Kolbenringsatz	Juego de anillos Jeu de segments	+0,50 mm	
1	5100005435	1	Set of piston rings Kolbenringsatz	Juego de aros de pistón Jeu de segments de piston		
2	5100005436	1	Piston Kolben	Pistón Piston		
2	5100019661	1	Piston Kolben	Pistón Piston	0,25	
2	5100019662	1	Piston Kolben	Pistón Piston	0,50	
3	5100005348	1	Piston pin Kolbenbolzen	Perno de pistón Axe de piston		
4	5200006505	1	Connecting rod cpl. Pleuel kpl.	Biela compl. Bielle compl.		
5	5100005438	2	Screw Schraube	Tornillo Vis	6x34,4	
6	0081994	2	Retaining ring Drahtsprengring	Anillo de retención Anneau de retenue		

Camshaft
Nockenwelle
Arbol de levas
Arbre à cames

WP1540Aw US

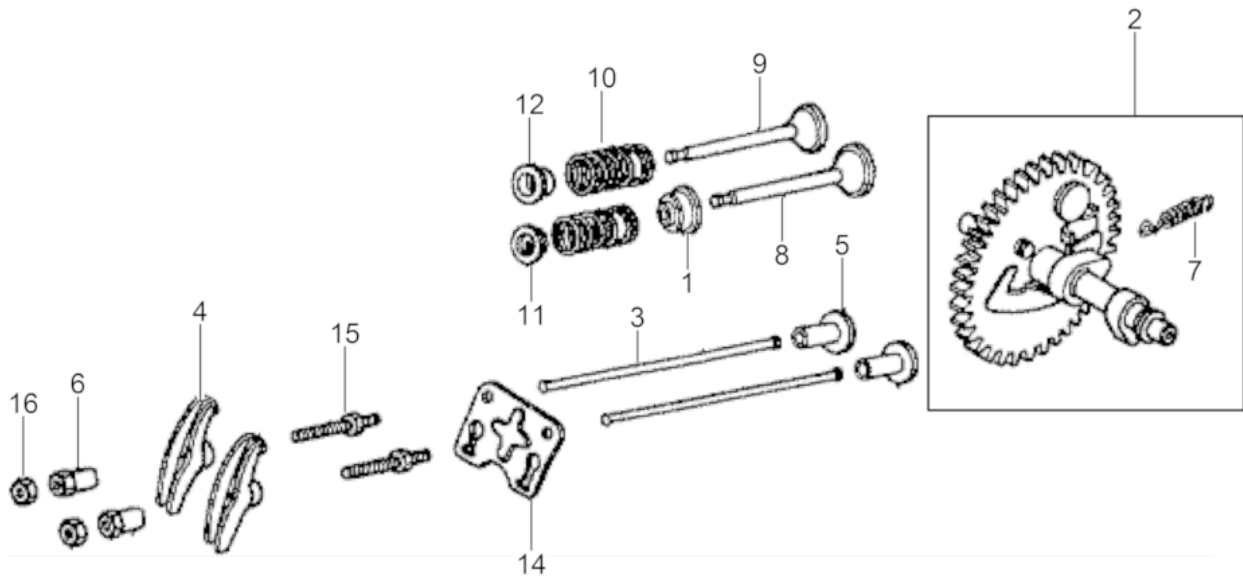

Ref. Pos.	Part No. Artikel Nr.	Qty. St.	Description Beschreibung	Descripción Description	Measurem./Abm.	Norm
					Torque/Drehm.	Sealant Schmierstoff
1	5100005349	1	Gasket Dichtung	Junta Joint		
2	5100005439	1	Camshaft cpl. Nockenwelle kpl.	Arbol de levas cpl. Arbre à cames cpl.		
3	5100005440	2	Push rod Schubstange	Varilla de empuje Pousoir		
4	0070986	2	Rocker arm Kipphebel	Balancín Culbuteur		
5	0070990	2	Valve tappet Ventilstößel	Levantaválvula Pousoir		
6	0070985	2	Rocker arm pivot Einstellmutter	Espaciador Pivot		
7	0151028	1	Spring Feder	Resorte Ressort		
8	5100005441	1	Intake valve Einlassventil	Válvula de admisión Soupape d'admission		
9	5100005442	1	Outlet valve Auslassventil	Válvula de escape Soupape d'échappement		
10	0081760	2	Spring Feder	Resorte Ressort		
11	0070996	1	Holder Halter	Soporte Attache		
12	0070996	1	Holder Halter	Soporte Attache		
14	5100005443	1	Guide plate Führungsblech	Chapa de guía Tôle de guidage		
15	0072778	2	Stud Gewindebolzen	Perno prisionero Boulon	8	
16	0070984	2	Locknut Sechskantmutter	Contratuercas Contre-écrou	1/4-28in	

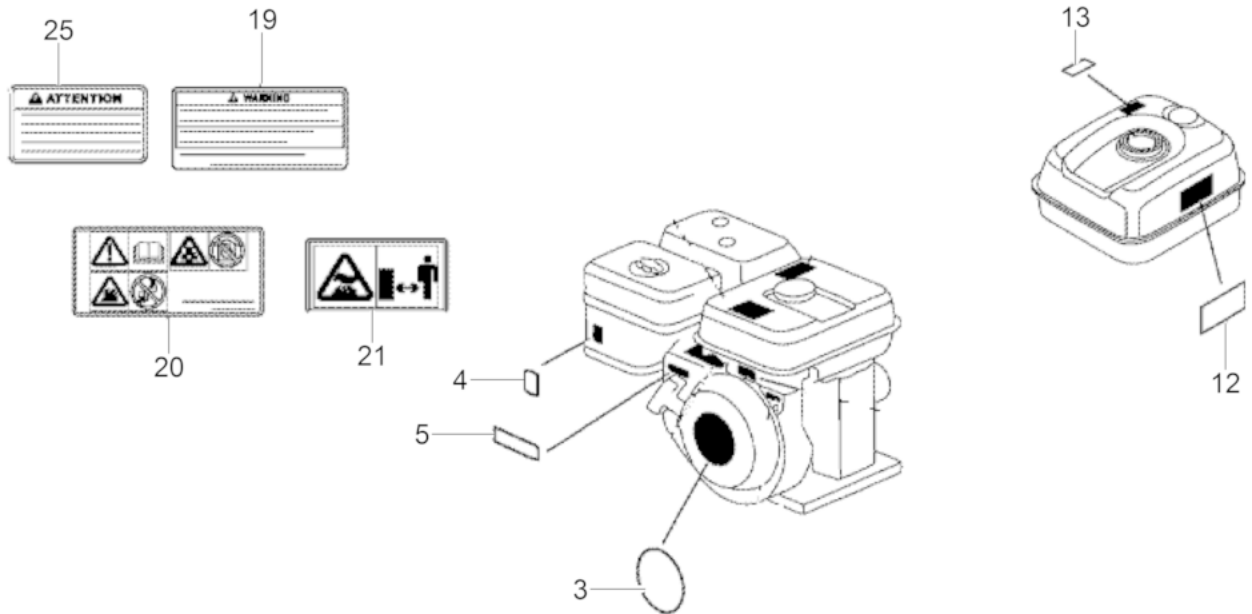

Ref. Pos.	Part No. Artikel Nr.	Qty. St.	Description Beschreibung	Descripción Description	Measurement./Abm.	Norm
					Torque/Drehm.	Sealant Schmierstoff
3	5100005352	1	Label GX160 Aufkleber GX160	Calcomanía GX160 Autocollant GX160		
4	5100005336	1	Label Aufkleber	Calcomanía Autocollant		
5	0208623	1	Labels Aufkleber	Calcomanías Autocollants		
12	5100000437	1	Warning Label Warnhinweiß	Etiqueta Amonestadora Étiquette D'avertissement		
13	5100005337	1	Label Aufkleber	Calcomanía Autocollant		
19	5100000438	1	Warning Label Warnhinweiß	Etiqueta Amonestadora Étiquette D'avertissement		
20	5100000439	1	Warning Label Warnhinweiß	Etiqueta Amonestadora Étiquette D'avertissement		
22	5100005340	1	Label Aufkleber	Calcomanía Autocollant		
25	5100005339	1	Label Aufkleber	Calcomanía Autocollant		



**WACKER
NEUSON**

**Accessories
Zubehör
Accesorios
Accessoires**

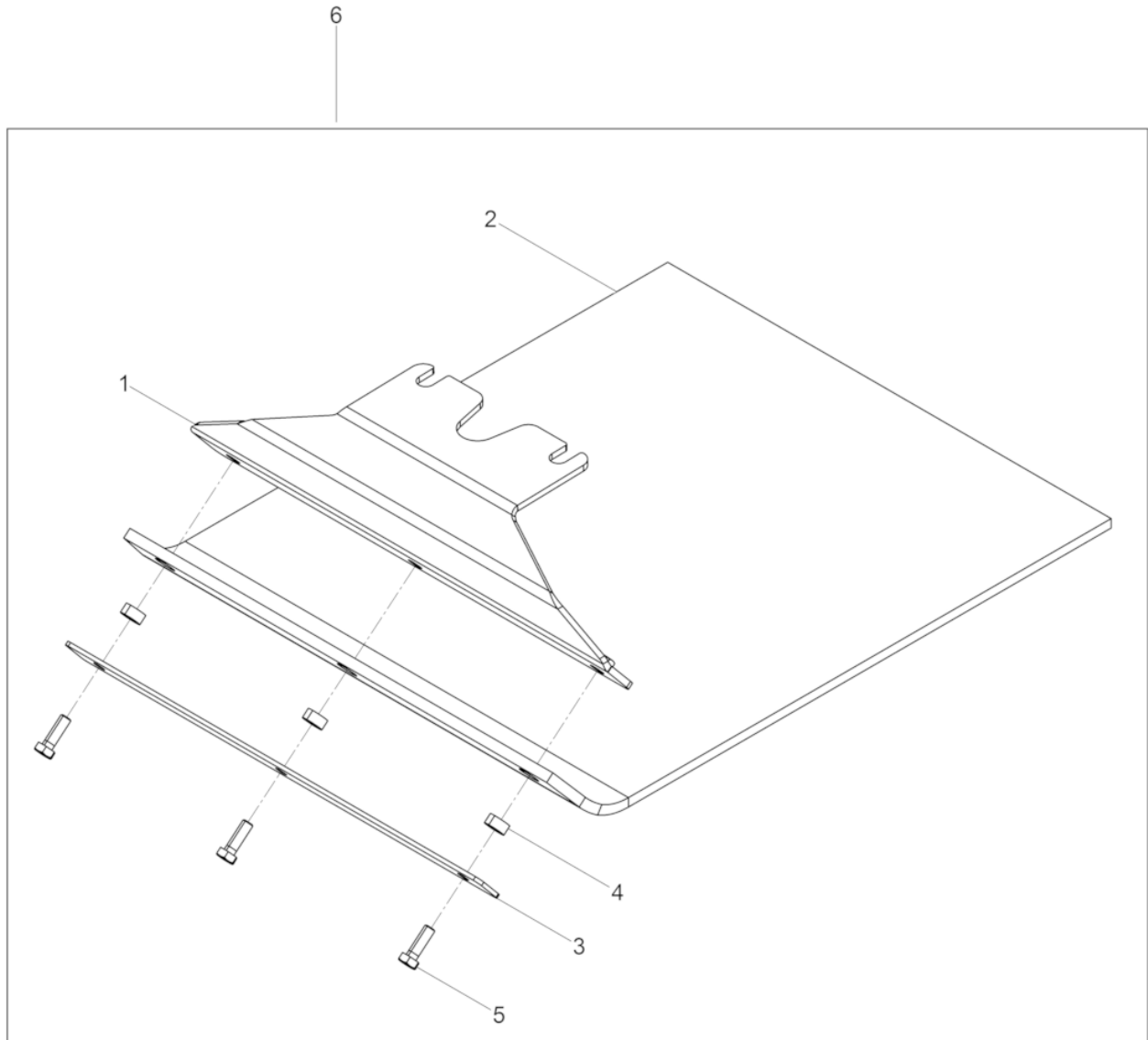

Ref. Pos.	Part No. Artikel Nr.	Qty. St.	Description Beschreibung	Descripción Description	Measurement/Abm.	Norm
					Torque/Drehm.	Sealant Schmierstoff
1	5100016464	1	Angle cpl. Winkel kpl.	Ángulo cpl. Coude cpl.		
2	5100016450	1	urethane plate Kunststoffplatte	Juego de lamina de uretano Dispositif de glissement		
3	5100016467	1	Plate Blech	Chapa Tôle		
4	5100017122	3	Bush Buchse	Buje Boîte		
5	0011457	3	Hexagonal head cap screw Sechskantschraube	Tornillo hexagonal Vis à tête hexagonale	M8 x 25 31Nm/23ft.lbs	DIN933
6	5100017107	1	Urethane Pad Kit PGV 1540 Gleitvorrichtung PGV 1540	Placa de Deslizamiento PGV 1540 Jeu de Tapis en Polyuréthane		

Trolley cpl.
Fahrgestell kpl.

WP1540Aw US

Dispositivo de Transporte cpl.
Chassis cpl.

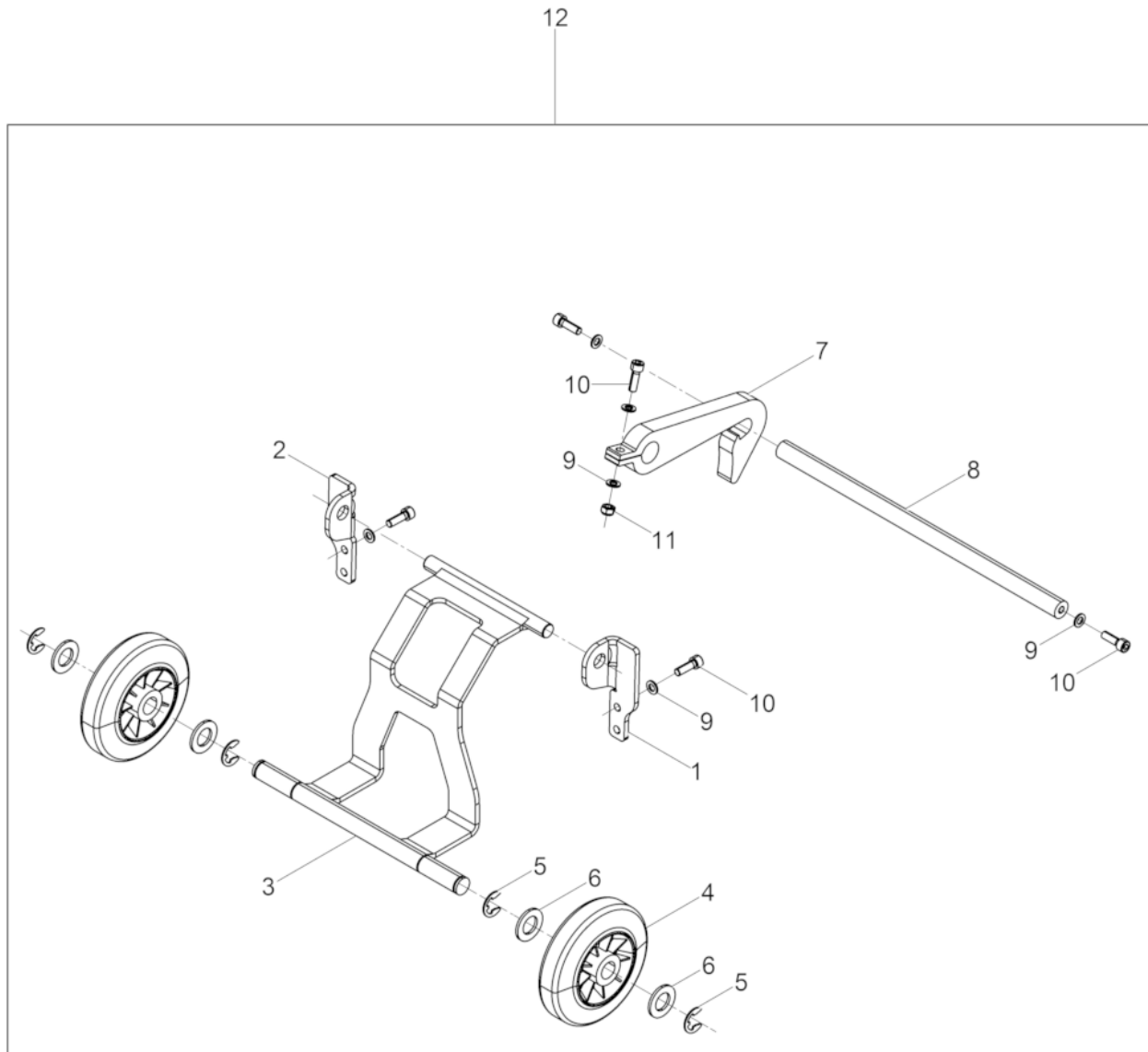

Ref. Pos.	Part No. Artikel Nr.	Qty. St.	Description Beschreibung	Descripción Description	Measurem./Abm.	Norm
					Torque/Drehm.	Sealant Schmierstoff
1	5100016472	1	Bracket Halter	Soporte Support		
2	5100016471	1	Bracket Halter	Soporte Support		
3	5100016469	1	Trolley Fahrgestell	Dispositivo de Transporte Chassis		
4	0021466	2	Tire Rad	Rueda Roue	140 x 37,5	
5	0103834	4	Lock washer Sicherungsscheibe	Arandela de seguridad Rondelle d'arrêt	15	DIN6799
6	0010616	4	Flat washer Scheibe	Arandela Rondelle		
7	5100016474	1	Hook Haken	Gancho Crochet		
8	5100018310	1	Brace Strebe	Puntual Contre-fiche		
9	0010742	8	Washer Scheibe	Arandela Rondelle		
10	0011542	7	Cheese head screw Zylinderschraube	Tornillo cilíndrico Vis à tête cylindrique	25Nm/18ft.lbs	
11	0033356	1	Hexagon nut Sechskantmutter	Tuerca hexagonal Écrou hexagonal		
12	5100016468	1	Trolley cpl. Fahrgestell kpl.	Dispositivo de Transporte cpl. Chassis cpl.		

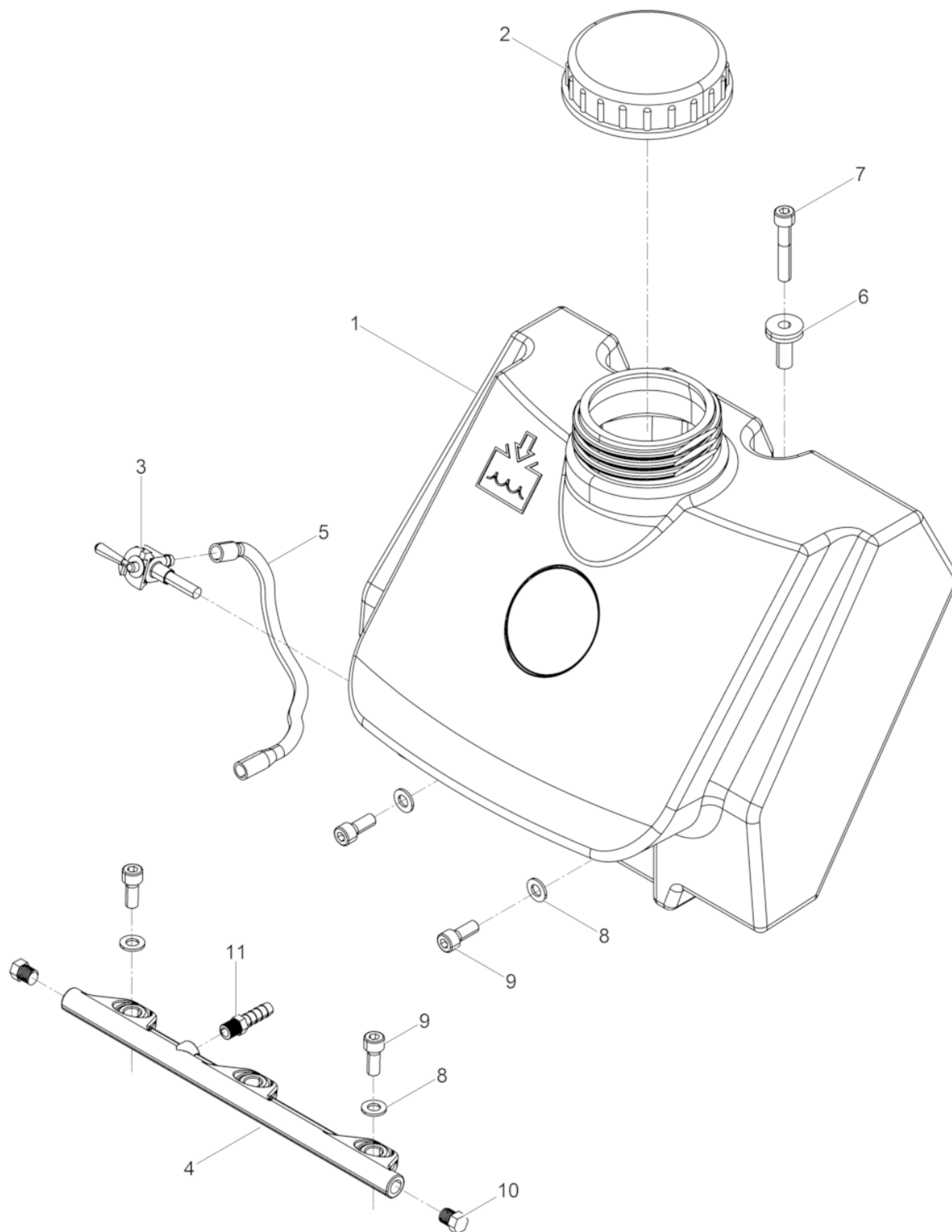

Ref. Pos.	Part No. Artikel Nr.	Qty. St.	Description Beschreibung	Descripción Description	Measurement/Abm.	Norm
					Torque/Drehm.	Sealant Schmierstoff
1	5100016315	1	Water tank Wassertank	Tanque de agua Reservoir à eau		
2	0068351	1	Screwed cover Schraubdeckel	Tapa roscable Couvercle fileté		
3	5100016618	1	Shutoff valve Wasserhahn	Grifo Robinet		
4	5100018335	1	Spinkler System Berieselung	Systema de Riego Installation d'Arrosage		
5	5100018315	1	Water Hose Wasserschlauch	Manguera de agua Tuyau d'eau	6x1,5x266 mm	
6	5100016451	2	Spacer sleeve Distanzhülse	Manguito distanciador Douille d'écartement		
7	0011538	2	Cheese head screw Zylinderschraube	Tornillo cilíndrico Vis à tête cylindrique	M8 x 45 25Nm/18ft.lbs	ISO4762
8	0010622	5	Flat washer Scheibe	Arandela Rondelle		
9	0011543	5	Socket head screw Zylinderschraube	Tornillo hueco Vis à six-pans creux	M8 x 20 24Nm/18ft.lbs	ISO4762
10	5100027000	2	Plug (threaded) Einschraubstopfen	Tapón Bouchon		
11	5100021610	1	Hose fitting Winkeleinschraubstutzen	Atornilladura angulara Manchon visse	No. 6 x 1/8in NPT x 90	
12	5100026164	1	Spinkler system cpl. Berieselung kpl.	Systema de riego cpl. Installation d'arrosage cpl.		



**WACKER
NEUSON**

**Service
Service
Servico
Service**

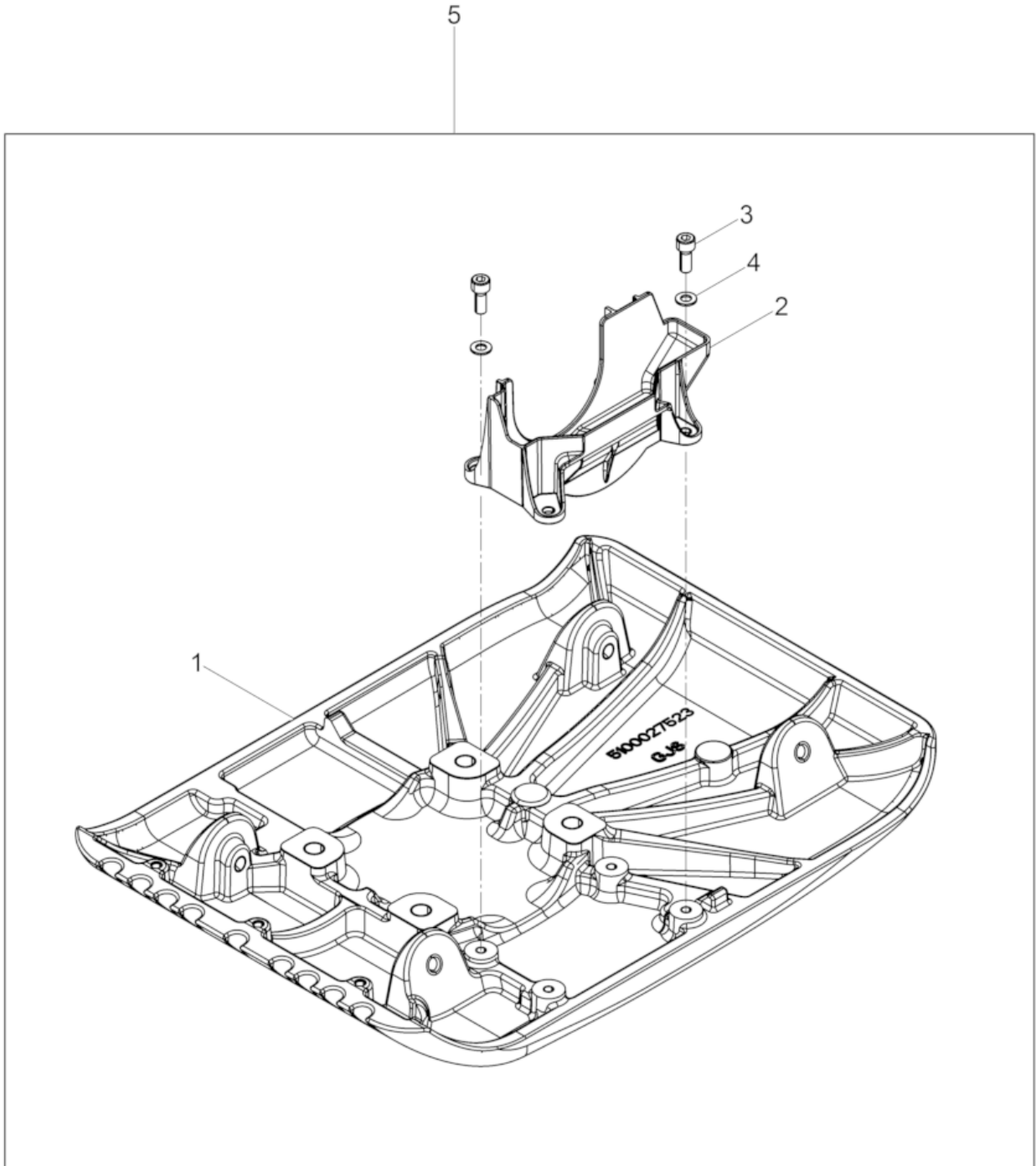

Ref. Pos.	Part No. Artikel Nr.	Qty. St.	Description Beschreibung	Descripción Description	Measurement./Abm.	Norm
					Torque/Drehm.	Sealant Schmierstoff
1	5100027524	1	Baseplate Untermasse	Masa inferior Masse inferieure		
2	5100018341	1	Belt Guard above Riemenschutz oben	Protección de la Polea Abajo Protection de Courroie Au-dess		
3	0011543	4	Socket head screw Zylinderschraube	Tornillo hueco Vis à six-pans creux	M8 x 20 25Nm/18ft.lbs	ISO4762
4	0010622	4	Flat washer Scheibe	Arandela Rondelle		
5	5100027672	1	Baseplate Belt guard Kit WP1540 Untermasse Riemenschutz Satz WP1540	Masa inferior Protección de la polea Juego WP1540 Masse inferieure Protection de		



**WACKER
NEUSON**