



**WACKER
NEUSON**

Ersatzteilkatalog
Spare parts list
Catalogo de piezas de repuesto
Catalogue des pièces détachées

**Vibrationsplatte
Vibratory plate
Plancha vibratoria
Plaque vibrante**

WP1550A



Invalid path 'S:\SAP_data_export_SP\100_5100018323_101_Q4\'

Type	WP1550A
Material Number	5100018323
Version	101
Language	de en es fr



www.wackerneuson.com

Copyright © 03.2019
Wacker Neuson Produktion GmbH & Co. KG
Printed in Germany.
All rights reserved.

Ein Typenschild mit Typ, Artikelnummer, Version und Maschinen-Nummer ist an jedem Gerät angebracht. Die Daten von diesem Schild bitte notieren, damit sie auch bei Verlust oder Beschädigung des Schildes noch vorhanden sind. Der Typ, die Artikelnummer, die Versions-Nummer und die Maschinen-Nummer sind bei der Ersatzteilbestellung oder Nachfragen bezüglich Service-Informationen stets erforderlich.

Bei den in den Ersatzteillisten fettgedruckten Nummern handelt es sich um empfohlene Ersatzteile. Dies bedeutet, daß diese Teile bei normalen Anwendungsbedingungen natürlicher Abnutzung ausgesetzt sind und gelegentlich ersetzt oder überarbeitet werden müssen. Es wird geraten, diese Teile auf Lager bereit zu haben, um für Service-Arbeiten an diesem Gerät vorbereitet zu sein. Lagerbestände für diese und andere Teile, welche für ausgiebigere Reparaturarbeiten benötigt werden, können je nach Service-Gewohnheiten der einzelnen Kunden variieren.

Die Nummern meines Gerätes sind:

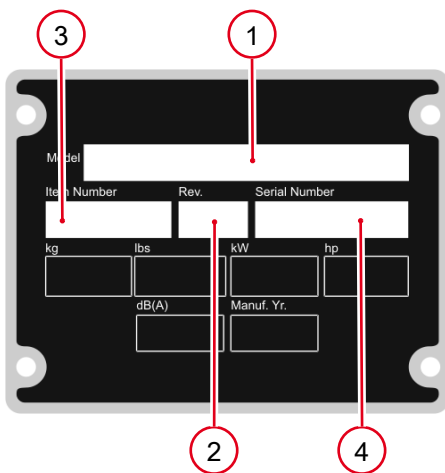

1. Typ
2. Version
3. Artikel-Nr.
4. Maschinen-Nr.

Umrechnungstabelle

Volumeneinheit	
1 ml	0.034 US fl.oz.
1 l	0.260 gal
Längeneinheit	
1 mm	0.039 in
1 m	3.280 ft
Gewicht	
1 kg	2.200 lbs
1 g	0.035 oz
Geschwindigkeit	
1 km/h	0.620 mph
Drehmoment	
1 Nm	0.740 ft.lbs

A nameplate listing the Model Number, Item Number, Revision, and Serial Number is attached to each unit. Please record the information found on this plate so it will be available should the nameplate become lost or damaged. When ordering parts or requesting service information, you will always be asked to specify the model, item number, revision number, and serial number of the unit.

Part Numbers appearing in boldface type are recommended spare parts. This means that these parts are subject to wear under normal operating conditions and may require periodic service or replacement. It is recommended that these items be stocked to meet the expected service requirements of this model. Actual stocking quantities of these and other parts used in more extensive repairs will depend on the service practices of each customer.

My machine's numbers are:



1. Model
2. Revision
3. Item No.
4. Serial No.

Conversion table

Volume unit	
1 ml	0.034 US fl.oz.
1 l	0.260 gal
Unit of length	
1 mm	0.039 in
1 m	3.280 ft
Weight	
1 kg	2.200 lbs
1 g	0.035 oz
Speed	
1 km/h	0.620 mph
Torque	
1 Nm	0.740 ft.lbs

Una placa de identificación con el modelo, número de referencia, nivel de revisión y número de serie ha sido añadida en cada máquina. Favor de anotar los datos en la placa en caso de que la placa de identificación sea destruida o perdida. En todos los pedidos para repuestos necesita siempre el modelo, el número de referencia, el nivel de revisión y el número de serie de la máquina en cuestión.

Los números de partes en negritas en las Listas Ilustradas de Partes son los repuestos recomendados, esto quiere decir que estas partes se desgastarán bajo circunstancias de funcionamiento normales y pueden requerir servicio periódico o su reemplazo. Se recomienda que el cliente mantenga un abastecimiento adecuado de estas partes para poder satisfacer la demanda requerida por el servicio a la máquina. La cantidad de repuestos que el cliente necesitará para reparaciones dependerá de la póliza de servicio de cada cliente.

Los números de mi máquina son:

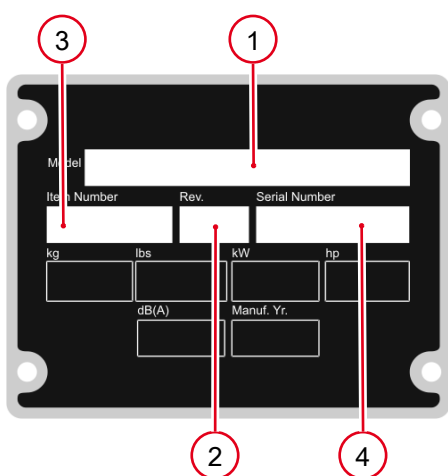

1. Modelo
2. Nivel de revisión
3. Número de referencia
4. Número de Serie

Tabla de conversión

Unidad de volumen	
1 ml	0.034 US fl.oz.
1 l	0.260 gal
Unidad de longitud	
1 mm	0.039 in
1 m	3.280 ft
Peso	
1 kg	2.200 lbs
1 g	0.035 oz
Velocidad	
1 km/h	0.620 mph
Par de apriete	
1 Nm	0.740 ft.lbs



Une plaque signalétique mentionnant le modèle, le numéro de référence, le niveau de revision et le numéro de série est fixée sur chaque machine. Veuillez noter les informations relevées sur cette plaque de façon à ce qu'elles soient toujours disponibles si la plaque signalétique venait à être perdue ou endommagée. Lorsque vous commandez des pièces détachées ou vous sollicitez des informations après-vente, on vous demandera toujours de préciser le modèle, le numéro de référence, le niveau de revision et le numéro de série de la machine.

Les numéros de pièces imprimés en caractères gras dans les Listes des Pièces Détachées de ce manuel sont les pièces détachées recommandées par la Wacker. Cela veut dire que ces pièces sont sujettes à usure dans des conditions de travail normales et peuvent nécessiter de l'entretien ou leur remplacement. Nous recommandons que vous disposez d'un stock de ces pièces pour pouvoir satisfaire la demande d'entretien de cette machine. Le client doit décider lui-même de la quantité exacte de pièces de rechange qu'il disposera dans ses stocks.

Les numéros de ma machine son :



1. Typ
2. Version
3. Artikel-Nr.
4. Maschinen-Nr.

Table de conversion

Unité de volume	
1 ml	0.034 US fl.oz.
1 l	0.260 gal
Unité de longueur	
1 mm	0.039 in
1 m	3.280 ft
Poids	
1 kg	2.200 lbs
1 g	0.035 oz
Vitesse	
1 km/h	0.620 mph
Couple de serrage	
1 Nm	0.740 ft.lbs

Vibrationplatte Kpl.
Vibratory Plate Cpl.
Plancha Vibradora Cpl.
Plaque Vibrante Cpl. 10

Vibrationplatte Kpl.
Vibratory Plate Cpl.
Plancha Vibradora Cpl.
Plaque Vibrante Cpl. 12

Bügel Kpl.
Shackle Cpl.
Estribo Cpl.
Étrier Cpl. 14

Erreger Kpl.
Exciter Cpl.
Excitador Cpl.
Excitateur Cpl. 16

Aufkleber
Labels
Calcomanias
Autocollants 18

Motor
Engine
Motor
Moteur

Seilzugarter
Starter
Arrancador
Démarreur 20

Gebläeabdeckung
Fan Hood
Tapa De Ventilador
Couvercle Du Sys. De Vent. 22

Vergaer
Carburetor
Carburador
Carburateur 24

Luftfilter
Air Cleaner
Filtro Del Aire
Filtre À Air 28

Schalldämpfer
Muffler
Silenciador
Silencieux 30

Kraftstofftank
Fuel Tank
Depósito De Combustible
Réservoir À Essence 32



Schwungrad Fly Wheel Volante Volant	34
Zylinderkopf Cylinder Head Culata Culasse	36
Zündpule Ignition Coil Bobina De Encendido Bobine D'allumage	38
Regler Governor Regulador Régulateur	40
Zylindergehäuse Cylinder Housing Carcasa De Cilindro Carter Cylindre	42
Kurbelgehäuseabdeckung Crankcase Cover Cubierta Da La Caja De Manivel Couvercle Carter De Manivelle	44
Kurbelwelle Crankshaft Cigueñal Vilebrequin	46
Kolben Piston Pistón Piston	48
Nockenwelle Camshaft Arbol De Levas Arbre À Cames	50
Aufkleber Labels Calcomanias Autocollants	52
Zubehör Accessories Accesorios Accessoires	
Gleitvorrichtung PGV 1550 Urethane Pad Kit Pgv 1550 Placa De Deslizamiento Pgv 1550 Jeu De Tapis En Polyuréthane	54



Fahrgetell Kpl. Trolley Cpl. Dispositivo De Transporte Cpl. Chassis Cpl.	56
Berieelunganlage Kpl. Water System Cpl. Sistema De Rociado Cpl. Système Diffuseur Cpl.	58
Berieelunganlage Kpl. < 101 Water System Cpl. < 101 Sistema De Rociado Cpl. <101 Système Diffuseur Cpl. <101	60

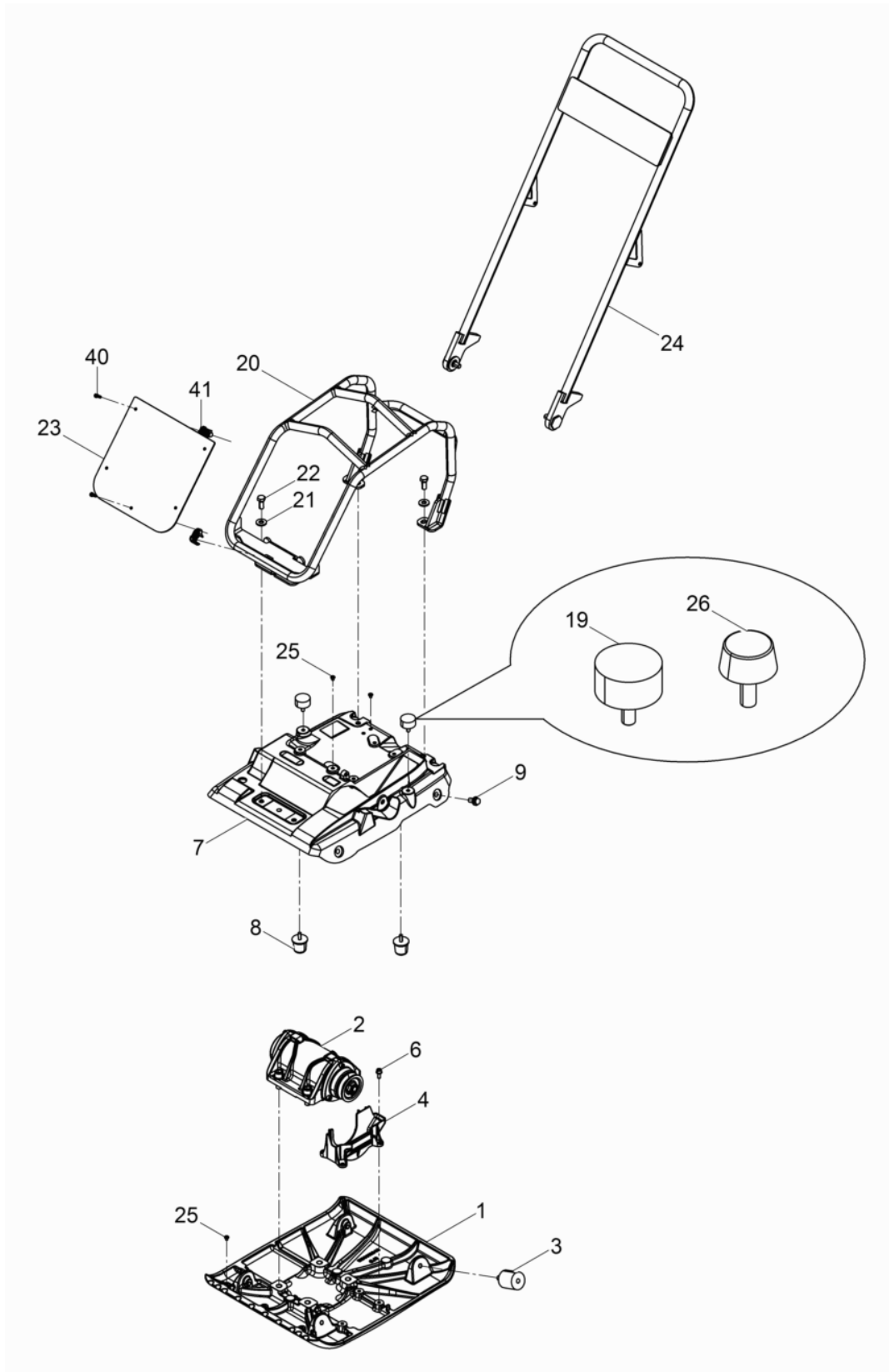

Pos. Ref.	Artikel Nr. Part No.	Qty.	Unit	Beschreibung Description	Description Description	Abm. Measur.	Norm Standard
						Drehm. Torque	Schmierstoff Sealant
1	5100016243	1	PC	Untermae Masa inferior	Baseplate Masse inferieure		
2	5100016322	1	PC	Erreger Kpl. Excitador cpl.	Exciter cpl. Excitateur cpl.		
3	5100016316	4	PC	Gummi-Metall-Puffer Tope caucho-metal	Shockmount Tampon metallique oscillant	50x55 40Nm/30ft.lbs	
4	5100018341	1	PC	Riemenchutz Unten Protección de la polea inferior	Belt guard below Protection de courroie		
6	5100042618	4	PC	Zylinderchraube Tornillo cilíndrico	Cheese head screw Vis à tête cylindrique	24Nm/18ft.lbs	
7	5100016326	1	PC	Konole Soporte	Bracket Support		
8	5100016327	2	PC	Anschlagpuffer Amortiguador	Shockmount Silentbloc	35 x 40 11Nm/8ft.lbs	
9	5100018059	4	PC	Sicherungschraube Tornillo de seguridad	Corrugated-head screw Vis de sécurité	38Nm/28ft.lbs	
19	5100017108	2	PC	Gummi-Metall-Puffer Tope caucho-metal	Shockmount Tampon métallique oscillant	40x20 11Nm/8ft.lbs	
20	5100045328	1	PC	Schutzrahmen Armazón de protección	Protective frame Cadre protection		
21	5000031565	4	PC	Spanncheibe Arandela elástica	Lockwasher Rondelle de ressort	12	DIN6796
22	5000011423	4	PC	Sechskantchraube Tornillo hexagonal	Hexagonal head cap screw Vis à tête hexagonale	M12 x 30 86Nm/63ft.lbs	DIN933
23	5100018317	1	PC	Abdeckung Cubierta	Covering Couverture		
24	5100028955	1	PC	Bügel Kpl. Estribo cpl.	Guide handle cpl. Étrier cpl.		
25	5002006531	9	PC	Verchlußstopfen Tapón	Push-in plug Bouchon	0,285in	
26	5100016317	2	PC	Anschlagpuffer Amortiguador	Shockmount Silentbloc	30 x 15	
40	5100013871	5	PC	Linenkopfchraube Tornillo gota de sebo	Oval head screw Vis noyée lentiforme	6 x 20	
41	5100018318	5	PC	Clip Presilla de retención	Clip-retaining Clé de serrage		

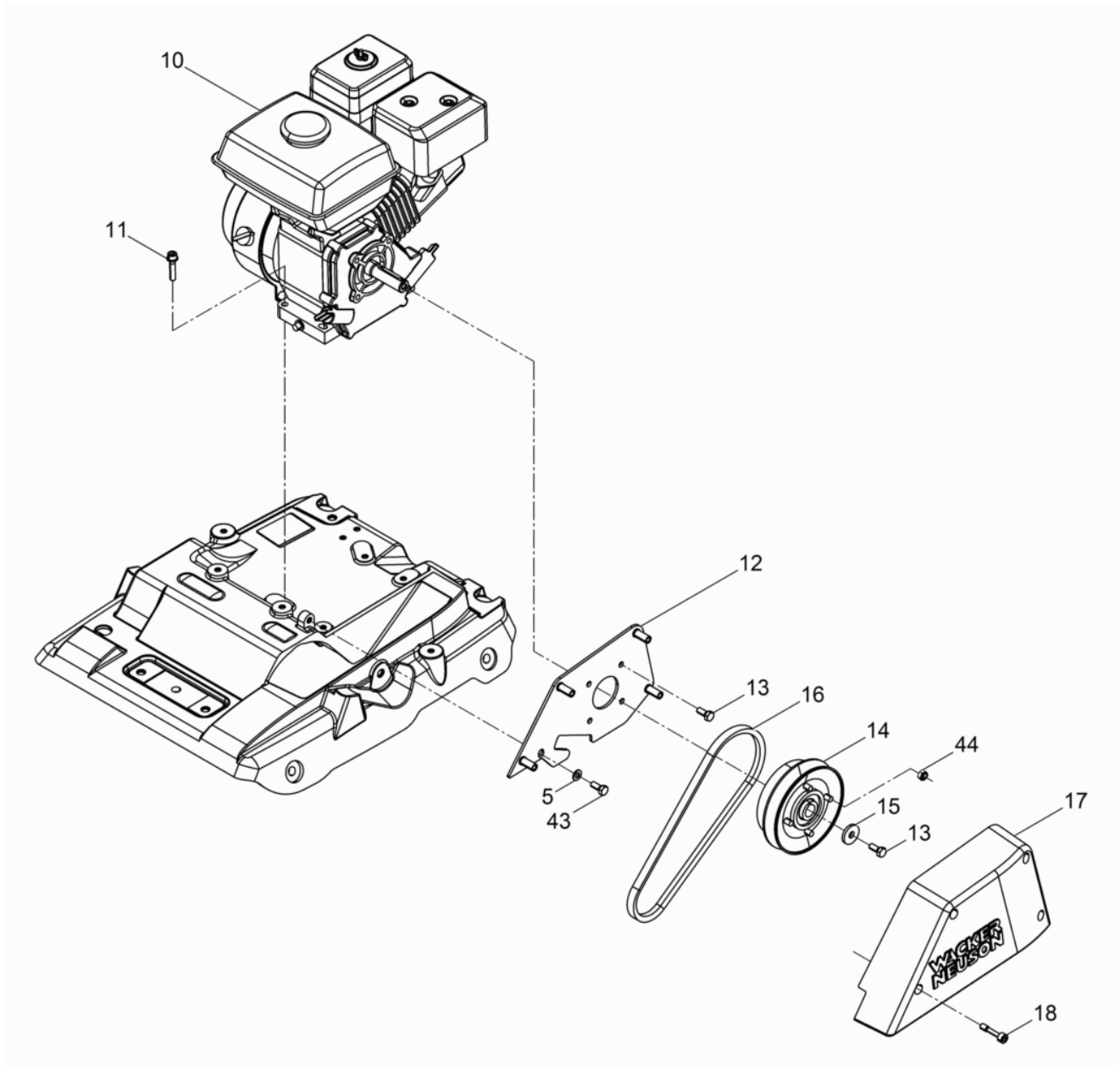

Pos. Ref.	Artikel Nr. Part No.	Qty.	Unit	Beschreibung Description	Description Description	Abm. Measur.	Norm Standard
						Drehm. Torque	Schmierstoff Sealant
5	5000010622	1	PC	Scheibe Arandela	Flat washer Rondelle		
10	5100018834	1	PC	Benzinmotor Motor a gasolina	Gas engine Moteur à essence		
11	5100036848	4	PC	Zylinderchraube Tornillo cilíndrico	Cheese head screw Vis à tête cylindrique	25Nm/18ft.lbs	
12	5100016434	1	PC	Keilriemenchutzblech Placa de protección	V-belt guard plate Plaque de protection		
13	5000026169	5	PC	Sechskantchraube Tornillo hexagonal	Hexagonal head cap screw Vis à tête hexagonale	5/16in-24UNF-2Ax 3/4in 18Nm/13ft.lbs	
14	5100016313	1	PC	Fliehkraftkupplung Embrague centrifugo	Centrifugal clutch Embrayage centrifuge		
15	5100016321	1	PC	Scheibe Arandela	Washer Rondelle		
16	5100044733	1	PC	Keilriemen Correa en v	V-belt Courroie		
17	5100025502	1	PC	Riemenchutz Protección de la polea	Belt guard Protection de courroie		
18	5000216658	4	PC	Dünnchaftchraube Tornillo	Screw Vis	M 8x 38	
43	5000012362	1	PC	Sechskantchraube Tornillo hexagonal	Hexagonal head cap screw Vis à tête hexagonale	25Nm/18ft.lbs	
44	5000033356	4	PC	Sechskantmutter Tuerca hexagonal	Hexagon nut Écrou hexagonal		

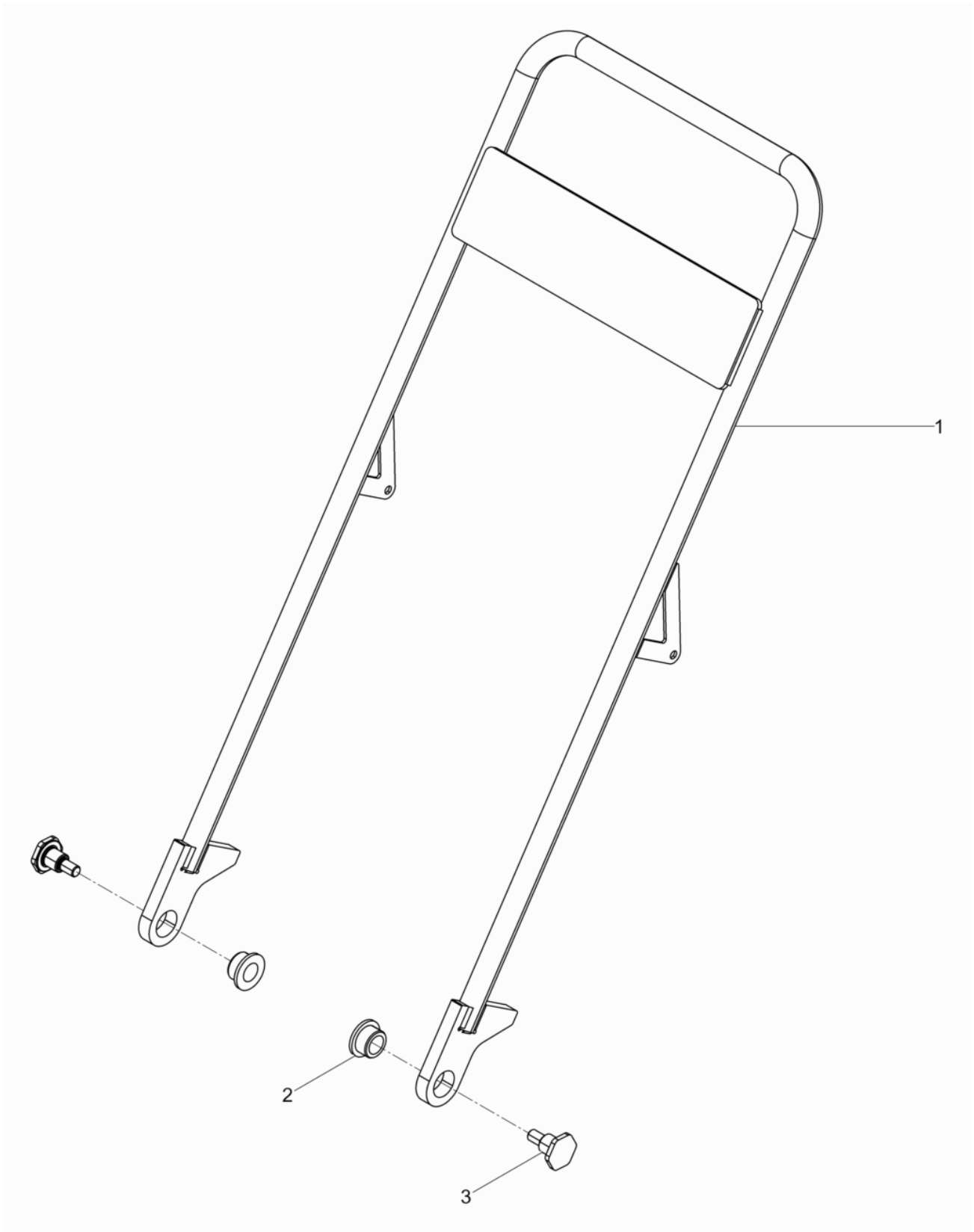

Pos. Ref.	Artikel Nr. Part No.	Qty.	Unit	Beschreibung Descripcion	Description Description	Abm. Measuram.	Norm Standard
						Drehm. Torque	Schmierstoff Sealant
1	5100028954	1	PC	Bügel Estribo	Shackle Étrier		
2	5100004367	2	PC	Buche Buje	Bush Boîte		
3	5100028928	2	PC	Buche Buje	Bush Boîte		

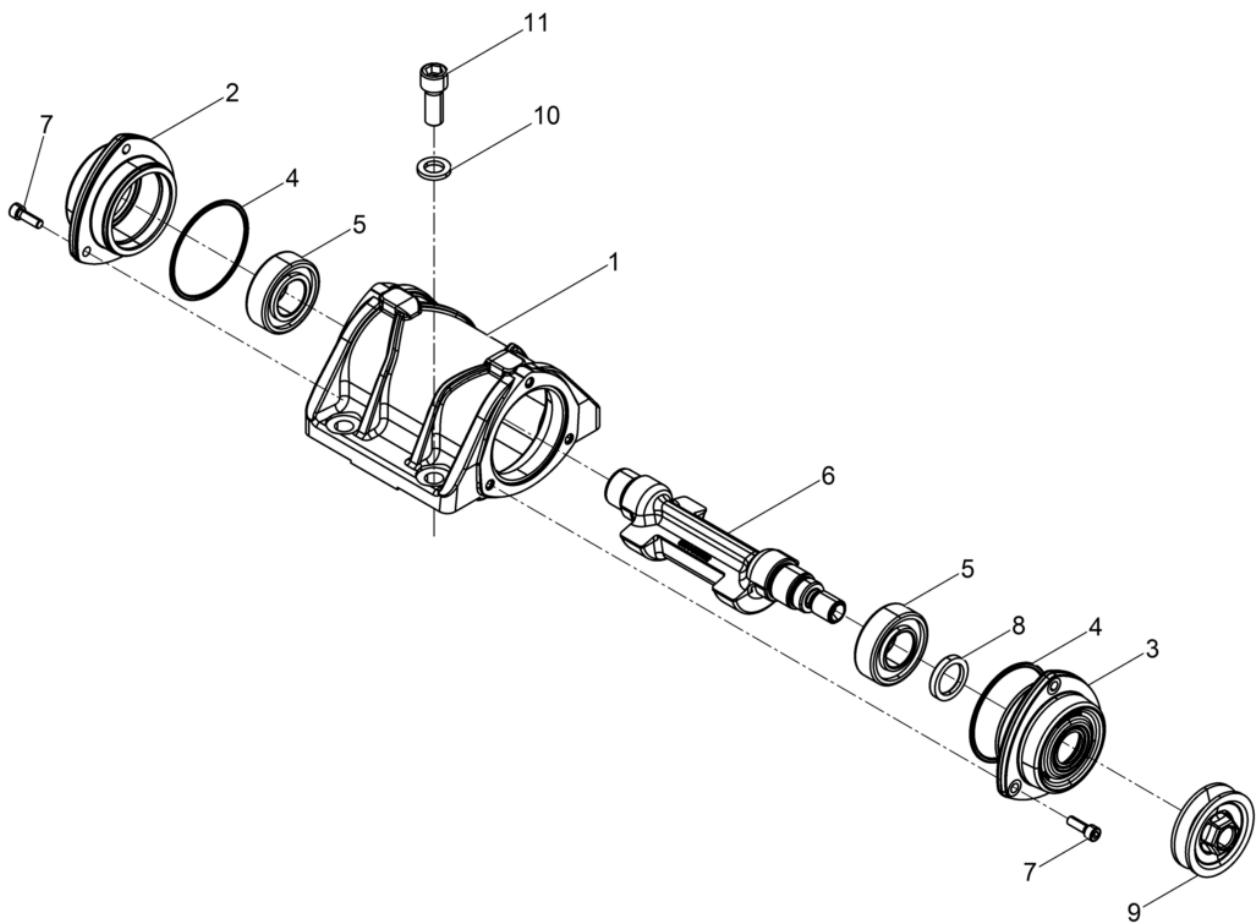

Pos. Ref.	Artikel Nr. Part No.	Qty.	Unit	Beschreibung Descripcion	Description Description	Abm. Measuram.	Norm Standard
						Drehm. Torque	Schmierstoff Sealant
1	5100016247	1	PC	Erregergehäuse Carcasa del excitador	Exciter housing Carter excitateur		
2	5100022486	1	PC	Lagerchild Placa de cojinete	Bearing bracket Bride palier		
3	5100022485	1	PC	Lagerchild Placa de cojinete	Bearing bracket Bride palier		
4	5100016445	2	PC	O-Ring Anillo-o	O-ring Bague-o	88,49 x 3,53	
5	5100018326	2	PC	Zylinderrollenlager Rodamiento cilíndricos	Cylindrical roller bearing Roulement à rouleaux		
6	5100018133	1	PC	Unwuchtwelle Eje de la masa excéntrica	Eccentric shaft Arbre portant l'excentrique		
7	5100029787	6	PC	Zylinderchraube Tornillo cilíndrico	Cheese head screw Vis à tête cylindrique	22Nm/16ft.lbs	
8	5100016446	1	PC	Wellendichtring Anillo de retén radial	Rotary shaft seal Bague d'étanchéité	B 30 x 42 x 7	
9	5100022460	1	PC	Keilriemencheibe Polea en v	V-belt pulley Poulie à courroie		
10	5100034545	4	PC	Scheibe Arandela	Washer Rondelle		
11	5100034546	4	PC	Zylinderchraube Tornillo cilíndrico	Cheese head screw Vis à tête cylindrique	210Nm/155ft.lbs	

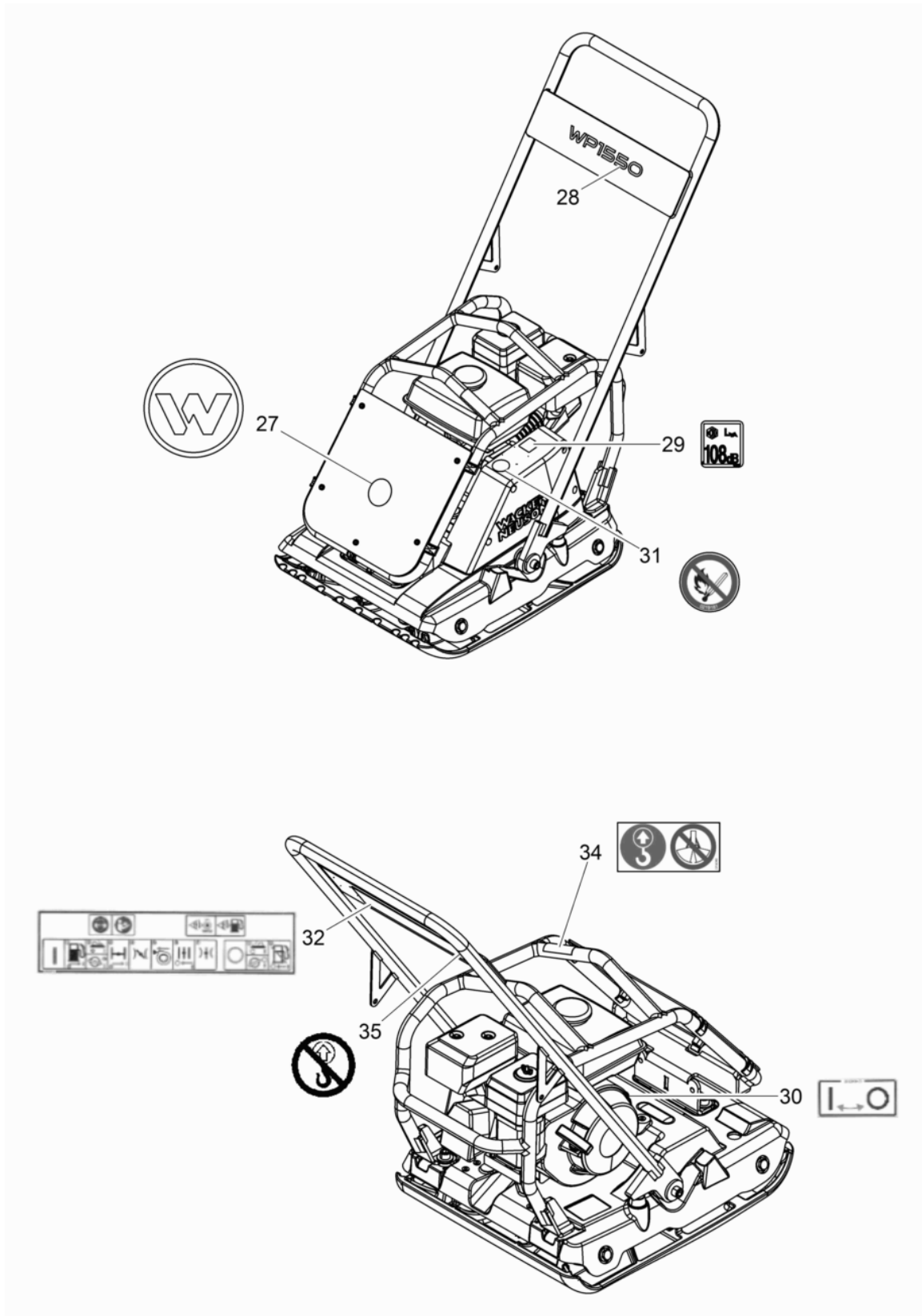

Pos. Ref.	Artikel Nr. Part No.	Qty.	Unit	Beschreibung Description	Description Description	Abm. Measur.	Norm Standard
						Drehm. Torque	Schmierstoff Sealant
27	5000222085	1	PC	Aufkleber Symbol Calcomania simbolo	Label symbol Autocollant symbole		
28	5100016454	1	PC	Aufkleber-Typ Tipo etiqueta autoadhesiva	Type label Autocollant de type		
29	5000129784	1	PC	Aufkleber-Schalleitungspegel Etiqueta autoadhesiva-nivel de potencia acúëstica	Decal-sound power level Autocollante-niveau sonore		
30	5100016455	1	PC	Aufkleber (ON-OFF) Calcomania (on-off)	Label (on-off) Autocollant (on-off)		
31	5000219181	1	PC	Aufkleber Calcomanias	Labels Autocollants		
32	5100018423	1	PC	Aufkleber Calcomania	Label Autocollant		
34	5000219260	1	PC	Aufkleber Calcomanias	Labels Autocollants		
35	5000220000	1	PC	Aufkleber-Warnhinwei Calcomanía-indicación	Instruction label Autocollant avec indication		

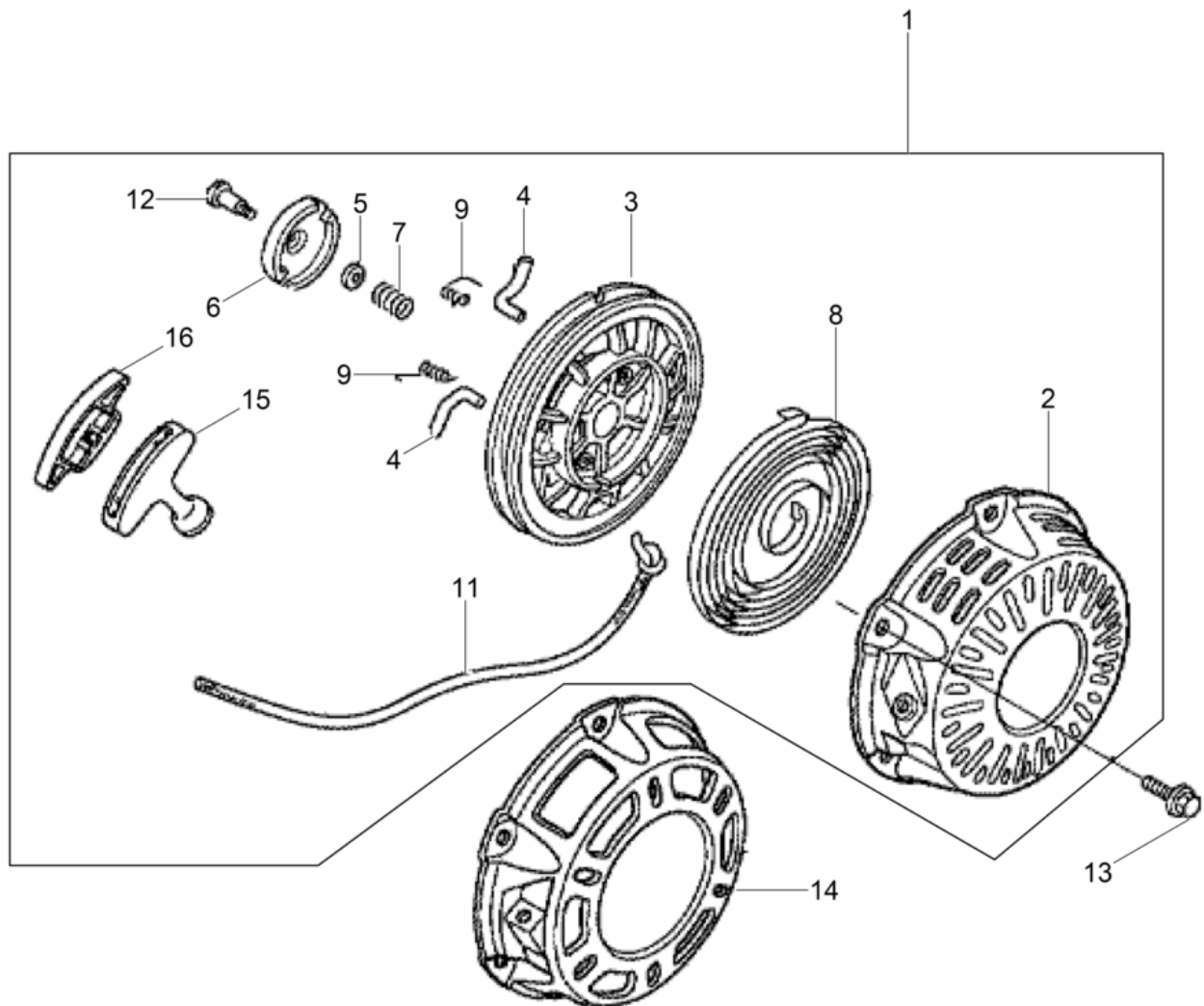

Pos. Ref.	Artikel Nr. Part No.	Qty.	Unit	Beschreibung Descripcion	Description Description	Abm. Measuram.	Norm Standard
						Drehm. Torque	Schmierstoff Sealant
1	5100005305	1	PC	Seilzugtarter Kpl. US(Chwarz) Arrancador cpl. us (negro)	Starter cpl. us (black) Démarrreur cpl. us (noir)		
1	5100005366	1	PC	Seilzugtarter Kpl. (Rot) Arrancador cpl. (rojo)	Starter cpl. (red) Démarrreur cpl. (rouge)		
1	5100005367	1	PC	Seilzugtarter Kpl. (Chwarz) Arrancador cpl. (negro)	Starter cpl. (black) Démarrreur cpl. (noir)		
1	5100005368	1	PC	Seilzugtarter Kpl. US (Rot) Arrancador cpl. us (rojo)	Starter cpl. us (red) Démarrreur cpl. us (rouge)		
2	5100005307	1	PC	Gehäuse Kpl. (Chwarz) Carcasa cpl. (negro)	Housing cpl. (black) Carter cpl. (noir)		
2	5100005369	1	PC	Gehäuse Kpl. (Rot) Carcasa cpl. (rojo)	Housing cpl. (red) Enveloppe cpl. (rouge)		
3	5100005308	1	PC	Seilcheibe Polea para cuerda	Rope disc Poulie de démarrage		
4	5000160527	2	PC	Ratche Trinquete	Ratchet Cliquet		
5	5000160748	1	PC	Reibplatte Placa de fricción	Friction plate Plaque à friction		
6	5000160745	1	PC	Führung Guía	Guide Guide		
7	5000160747	1	PC	Reibfeder Resorte de fricción	Friction spring Ressort à friction		
8	5000081777	1	PC	Feder Resorte	Spring Ressort		
9	5000207990	2	PC	Schenkelfeder Resorte	Spring Ressort		
11	5000081781	1	PC	Startereil Cuerda	Rope Corde		
12	5000207991	1	PC	Schraube Tornillo	Screw Vis		
13	5000158458	3	PC	Flanchbolzen Tornillo de perno	Flange bolt Vis de boulon	6 x 10	
15	5100005309	1	PC	Startergriff US Empuñadura del starter us	Starter handle us Poignée du lanceur us		
15	5100005413	1	PC	Startergriff Empuñadura del starter	Starter handle Poignée du lanceur		
16	5100005310	1	PC	Abdeckung Cubierta	Covering Couverture		

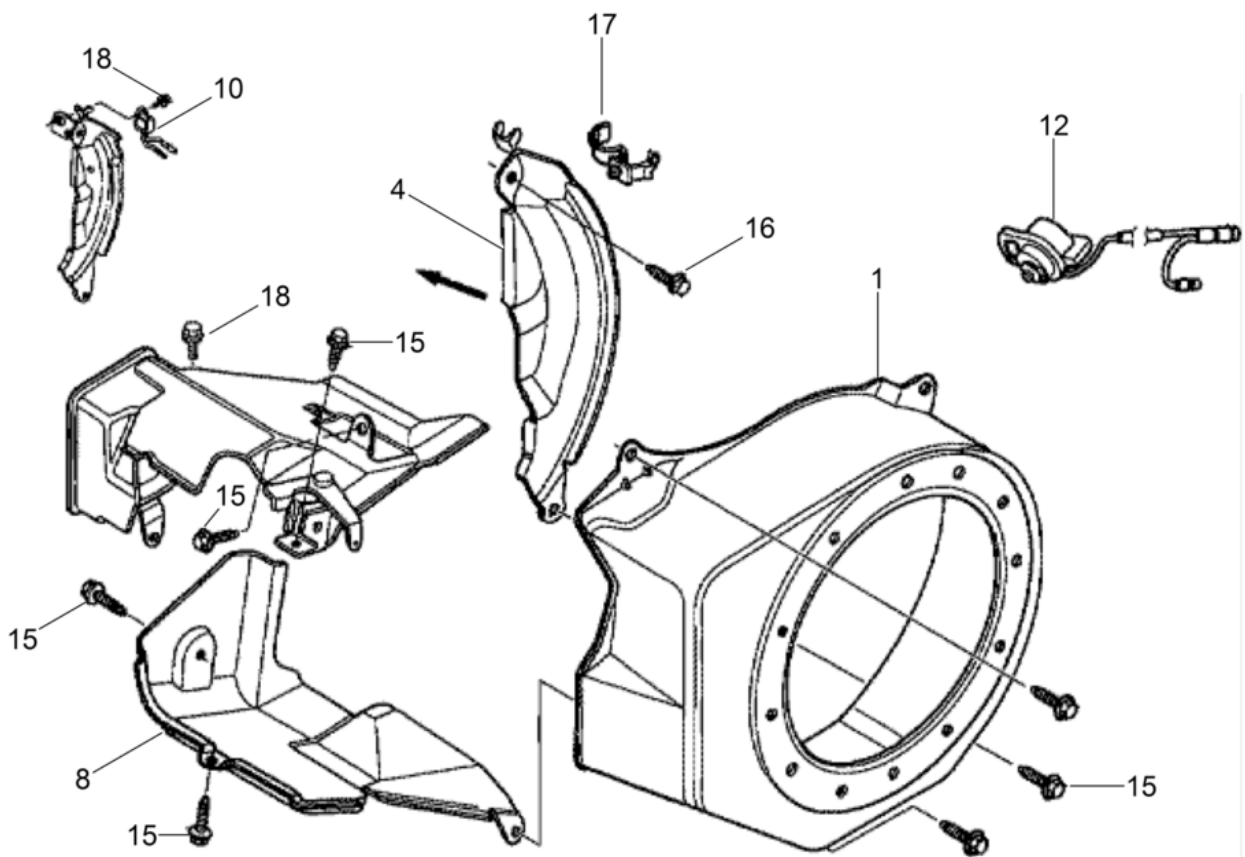

Pos. Ref.	Artikel Nr. Part No.	Qty.	Unit	Beschreibung Descripcion	Description Description	Abm. Measur.	Norm Standard
						Drehm. Torque	Schmierstoff Sealant
1	5100005311	1	PC	Gebeläeabdeckung Kpl. (Chwarz) Tapa de ventilador cpl. (negro)	Fan hood cpl. (black) Couvercle du sys. de vent. cpl		
1	5100005354	1	PC	Gebeläeabdeckung Kpl. Tapa de ventilador cpl.	Fan hood cpl. Couvercle du sys. de vent. cpl		
4	5100005312	1	PC	Abdeckung Cubierta	Covering Couverture		
8	5100005414	1	PC	Halterung Kpl. Soporte cpl.	Bracket cpl. Équerre cpl.		
10	5100003471	1	PC	Ölenor Alerta de aceite	Oil sensor Alerte d'huile		
12	5000162682	1	PC	Schalter Kpl. Interruptor compl.	Switch assembly Interrupteur compl.		
15	5000053990	6	PC	Schraube Tornillo	Screw Vis	M6 x 12 10Nm/7ft.lbs	
16	5000071055	1	PC	Schraube Tornillo	Screw Vis	M6 x 20 10Nm/7ft.lbs	
17	5000153138	1	PC	Schelle Abrazadera	Clamp Collier		
18	5000162077	1	PC	Flanchschraube Tornillo de brida	Flange screw Vis de bride		

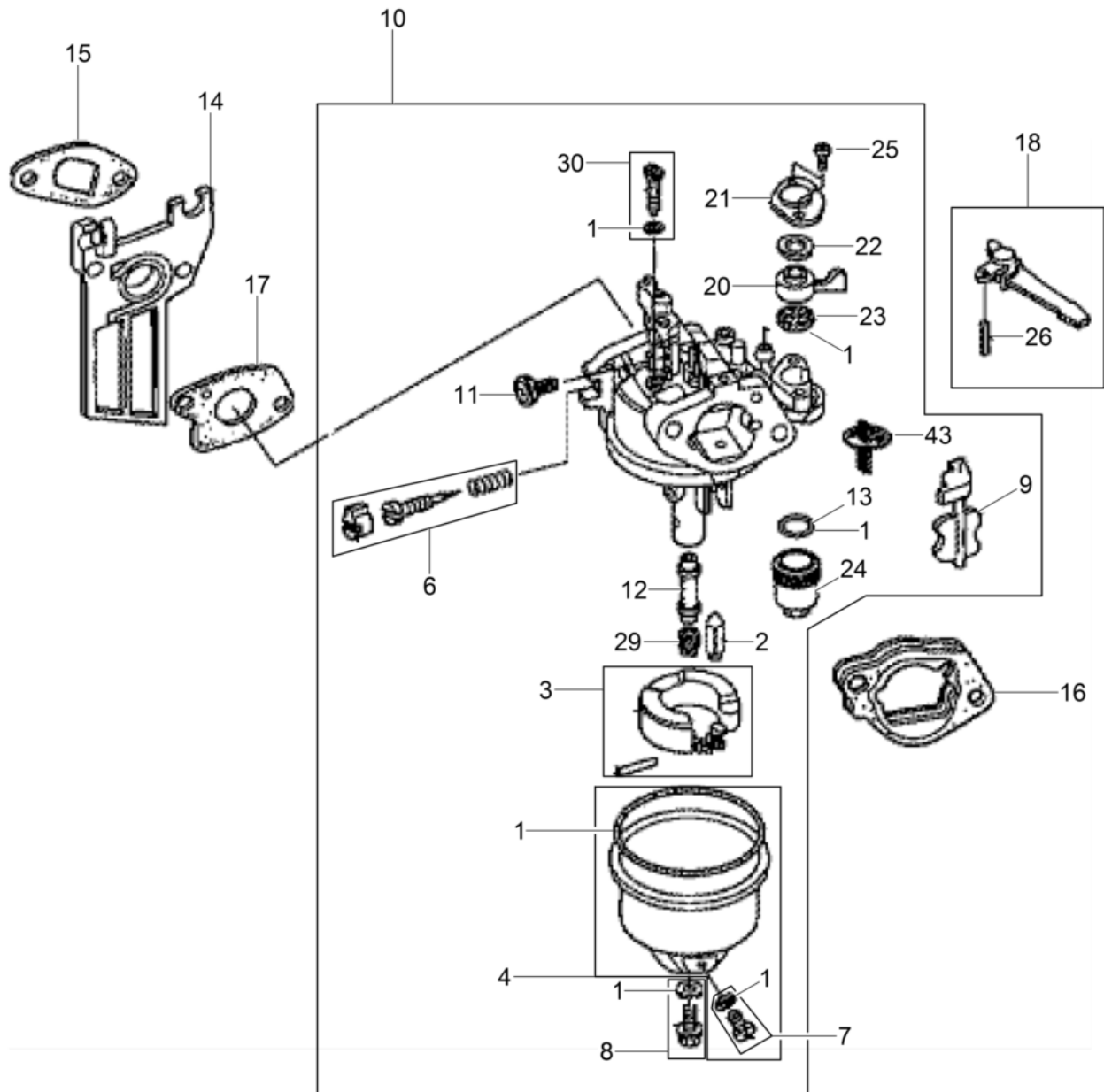

Pos. Ref.	Artikel Nr. Part No.	Qty.	Unit	Beschreibung Descripcion	Description Description	Abm. Measur.	Norm Standard
						Drehm. Torque	Schmierstoff Sealant
1	5000072781	1	PC	Dichtungatz Juego de juntas	Set-gaskets Jeu de joints		
2	5000071022	1	PC	Schwimmernadel Kpl. Válvula de flotador	Set-float valve Pointeau du carburateur		
3	5000209764	1	PC	Schwimmer Kpl. Juego de flotador	Set-carburetor float Jeu de flotteur		
4	5100005314	1	PC	Schwimmergehäuse Cámara de flotador	Float housing Cuve à niveau constant		
6	5000089286	1	PC	Gewindetift Tornillo	Setscrew Vis		
7	5200000430	1	PC	Schraube Mit Scheibe Tornillo con arandela	Screw w/washer Vis avec rondelle		
8	5200000431	1	PC	Schraube Mit Scheibe Tornillo con arandela	Screw w/washer Vis avec rondelle		
9	5100005415	1	PC	Staterklappe Válvula de mariposa	Starter flap Volet de démarrage		
10	5000406637	1	PC	Vergaer Kpl. Carburador compl.	Carburetor cpl. Carburateur compl.		
11	5000071018	1	PC	Anschlagchraube Tornillo de tope	Throttle stop screw Vis		
12	5100009310	1	PC	Hauptdüse Chicler principal	Main jet Gicleur principal		
13	5000125839	1	PC	O-Ring Anillo-o	O-ring Joint torique		
14	5100005416	1	PC	Isolator Aislador	Isolator Isolateur		
15	5000082009	1	PC	Dichtung Junta	Gasket Joint		
16	5000071015	1	PC	Distanztück Espaciador	Spacer Pièce d'écartement		
17	5000081762	1	PC	Dichtung Junta	Gasket Joint		
18	5000071013	1	PC	Chokehebel Palanca estranguladora	Choke control lever Levier d'étrangleur		
20	5000150266	1	PC	Kraftoffhahn Palanca	Fuel valve lever Levier		
21	5000073269	1	PC	Platte Placa	Plate Plaque		
22	5000073270	1	PC	Federcheibe Arandela elástica	Spring washer Rondelle à ressort		
23	5000073272	1	PC	Dichtung Junta	Gasket Joint		
24	5000071023	1	PC	Kraftofffilter Filtro de combustible	Fuel filter Filtre à carburant		
25	5100005317	2	PC	Kegelkopfchraube 3X6 Tornillo	Screw Vis	3x6	
26	5000071014	1	PC	Stift Pasador	Pin Goupille	2 x 12	
29	5000207672	1	PC	Hauptdüse Chicler principal	Main jet Gicleur principal	62	
29	5100005417	1	PC	Hauptdüse Chicler principal	Main jet Gicleur prinzipal	65	
29	5100005417	1	PC	Hauptdüse Chicler principal	Main jet Gicleur prinzipal	65	
30	5000071016	1	PC	Leerlaufdüse Chicler ralenti	Pilot jet Gicleur de ralenti	35	

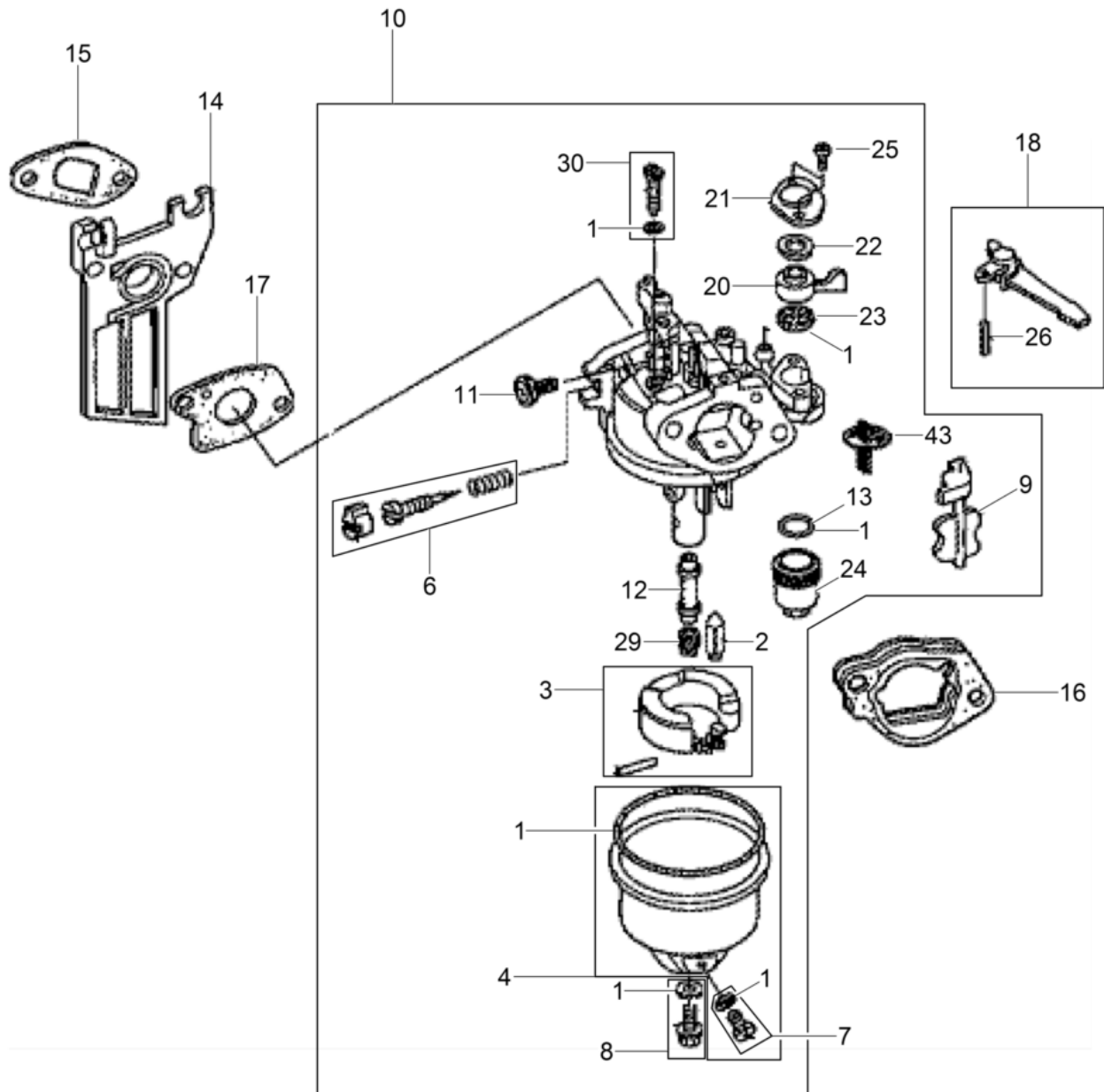

Pos. Ref.	Artikel Nr. Part No.	Qty.	Unit	Beschreibung Descripcion	Description Description	Abm. Measuram.	Norm Standard
						Drehm. Torque	Schmierstoff Sealant
43	5100000396	1	PC	Filter Filtro	Filter Filtre		

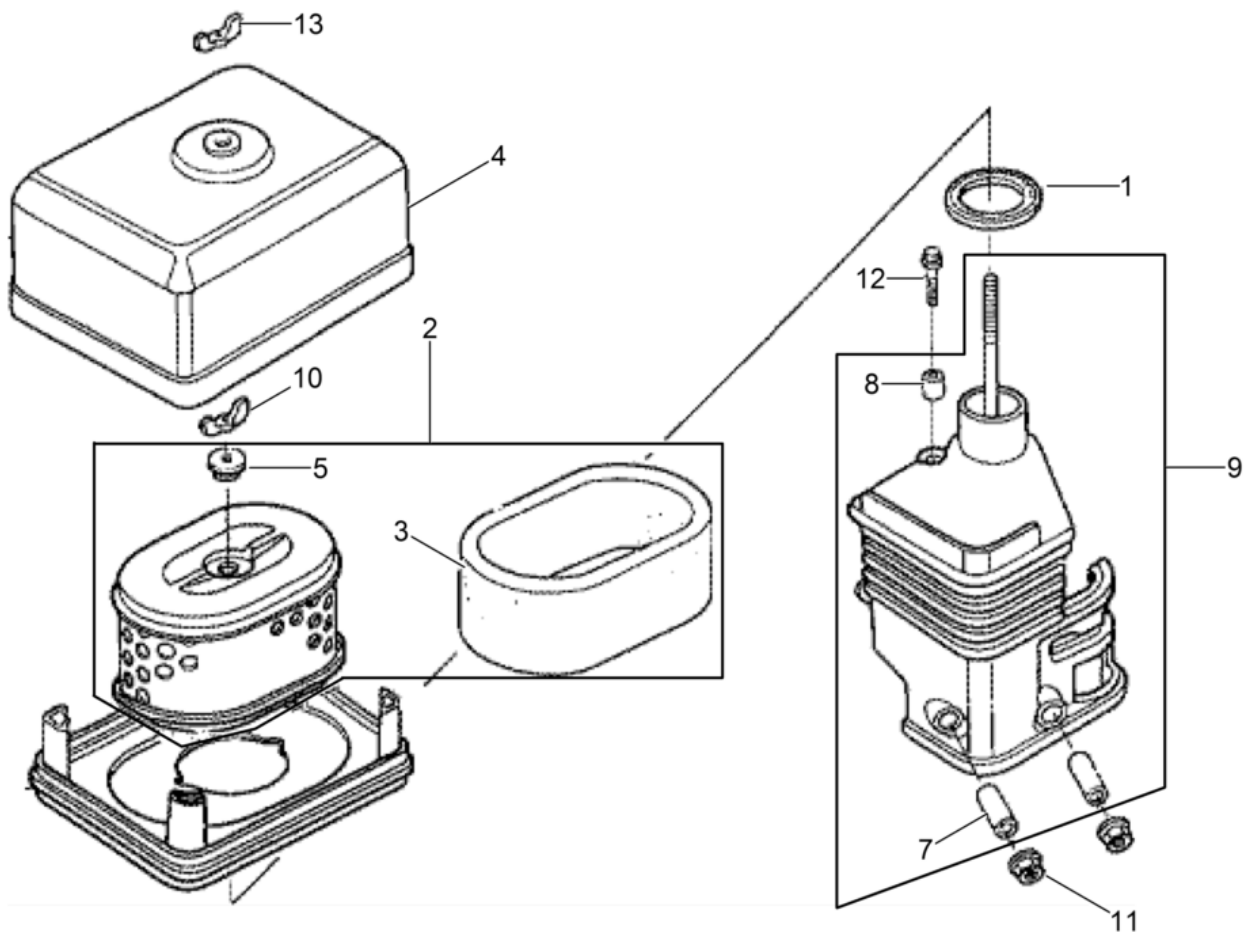

Pos. Ref.	Artikel Nr. Part No.	Qty.	Unit	Beschreibung Descripcion	Description Description	Abm. Measur.	Norm Standard
						Drehm. Torque	Schmierstoff Sealant
1	5000071032	1	PC	Dichtung Junta	Gasket Joint		
2	5100005319	1	PC	Luftfiltereinatz Elemento-filtro	Air cleaner element Elément filtrant		
3	5000217459	1	PC	Luftfiltereinatz Inserto para filtro de aire	Air filter insert Garniture filtre à air		
4	5100005419	1	PC	Filterdeckel Tapa de filtro	Filter cover Couvercle du filtre		
4	5100019660	1	PC	Luftfilterdeckel Tapa-filtro del aire	Air cleaner cover Couvercle-filtre à air		
5	5000072343	1	PC	Tülle Ojal	Grommet Passe-fil		
7	5000081746	2	PC	Hüle Collar	Sleeve Douille		
8	5000071035	1	PC	Hüle Manguito	Sleeve Douille		
9	5100005420	1	PC	Filterkonole Consola del filtro	Filter bracket Console de filtre		
10	5000071621	1	PC	Flügelmutter Tuerca mariposa	Wing nut Ecrou papillon	M6	
11	5000071056	2	PC	Mutter Tuerca	Nut Ecrou	M6	
12	5100003499	1	PC	Flanchschraube 6X20 Tornillo de brida	Flange screw Vis de bride	6x20	
13	5100005421	1	PC	Mutter Tuerca	Nut Ecrou		

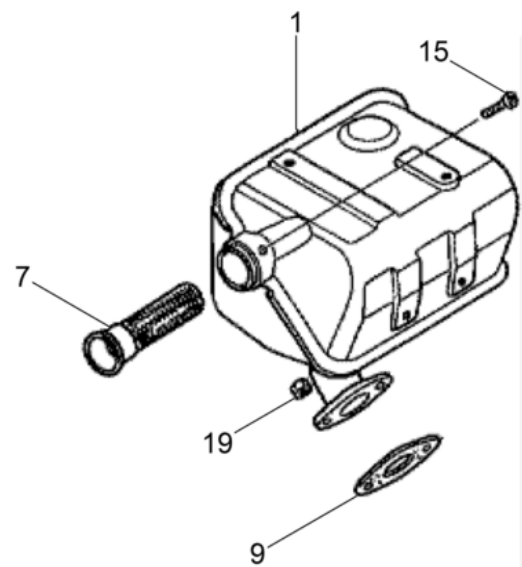
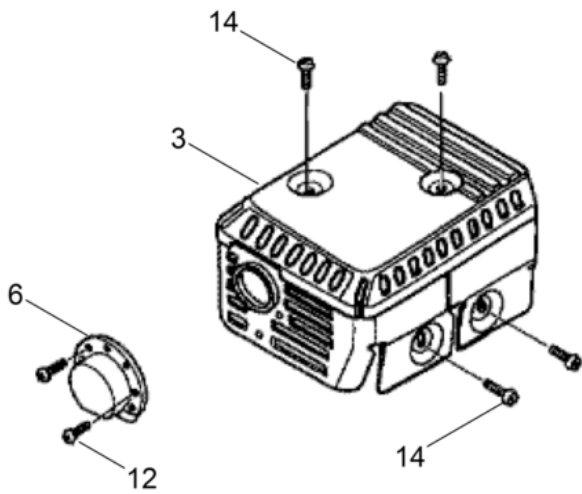

Pos. Ref.	Artikel Nr. Part No.	Qty.	Unit	Beschreibung Descripcion	Description Description	Abm. Measur.	Norm Standard
						Drehm. Torque	Schmierstoff Sealant
1	5100005364	1	PC	Schalldämpfer Kpl. Silenciador cpl.	Muffler cpl. Silencieux cpl.		
3	5000406646	1	PC	Schutz Protector	Guard Protection		
6	5000153130	1	PC	Führung Guía	Guide Guide		
7	5000071075	1	PC	Funkenfänger Parachispas	Spark arrester Pare-étincelles		
9	5000216516	1	PC	Dichtung Junta de estanqueidad	Gasket Garniture		
12	5000209783	2	PC	Schneidchraube Tornillo autorroscante	Self-tapping screw Vis autotaraudeuse	4 x 8	
14	5000071070	4	PC	Schraube Tornillo	Screw Vis	M5 x 8	
15	5000150916	1	PC	Schraube Tornillo	Screw Vis	M4x6	
19	5100003492	2	PC	Sechskantmutter M8 Tuerca hexagonal	Hexagon nut Écrou hexagonal	M8	

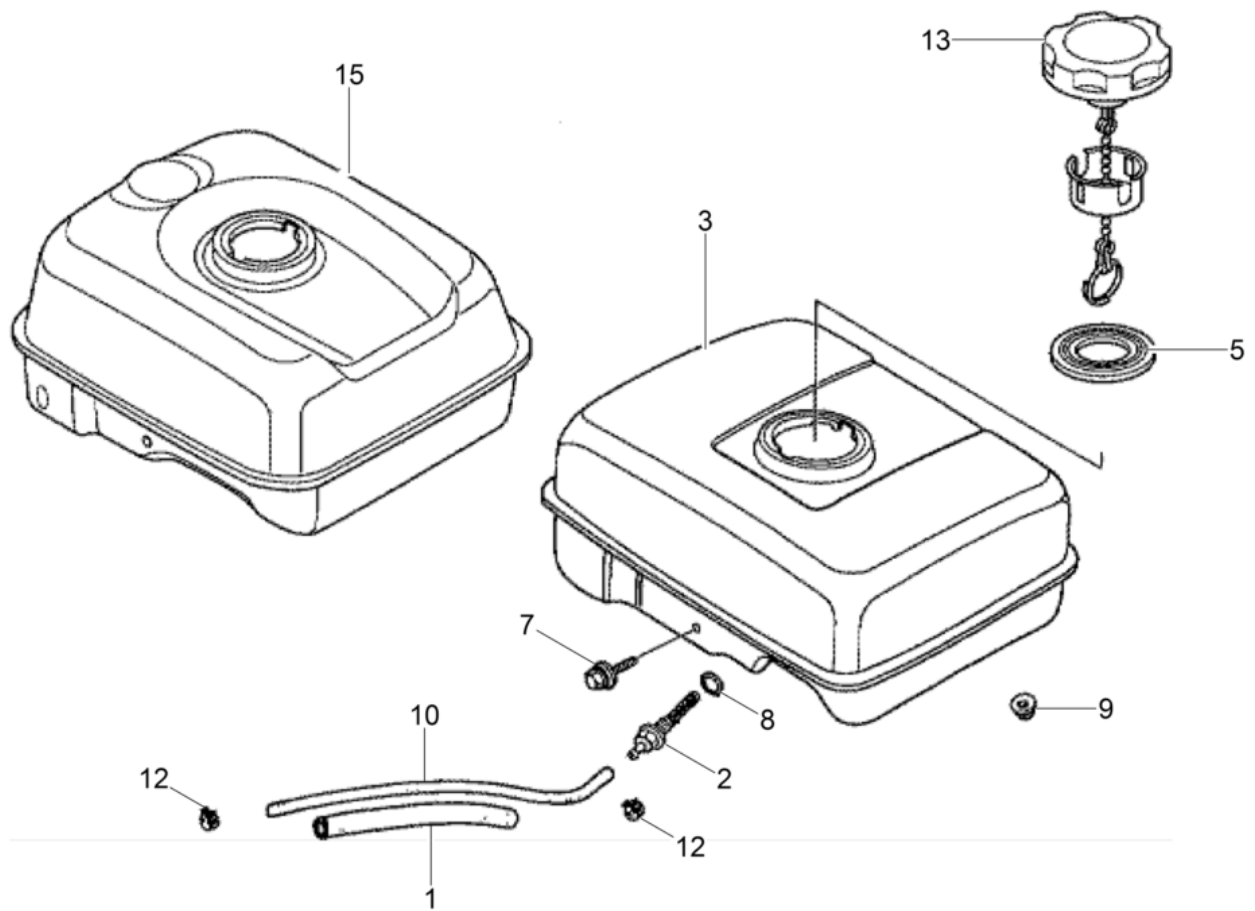

Pos. Ref.	Artikel Nr. Part No.	Qty.	Unit	Beschreibung Descripción	Description Description	Abm. Measur.	Norm Standard
						Drehm. Torque	Schmierstoff Sealant
1	5000081764	1	PC	Schlauchstück Manguera	Protective hose Tuyau		
2	5100000395	1	PC	Verbindungstück Conexión	Connection Connexion		
3	5000082013	1	PC	Kraftstofftank Tanque de combustible	Fuel tank Réservoir de carburant		
3	5000110765	1	PC	Kraftstofftank Depósito de combustible	Fuel tank Réservoir à essence		
5	5000209770	1	PC	Dichtung Junta de estanqueidad	Gasket Garniture		
7	5000209771	1	PC	Flanchbolzen Tornillo de perno	Flange bolt Vis de boulon	6x29	
8	5000208616	1	PC	O-Ring Anillo-o	O-ring Joint torique	14M	
9	5000071056	2	PC	Mutter Tuerca	Nut Ecrou	M6	
10	5100005325	1	PC	Kraftstoffschlauch 4,5X145 Manguera de combustible	Fuel hose Tuyau à essence	4,5x145	
12	5000208617	2	PC	Rohrschelle Abrazadera	Clamp Agrafe		
13	5000213409	1	PC	Schwungrad Volante	Flywheel Volant		
13	5100005357	1	PC	Tankdeckel Kpl. Tapa de tanque cpl.	Tank cover cpl. Couvercle du reservoir cpl.		
15	5100005323	1	PC	Kraftstofftank Kpl. Tanque de combustible cpl.	Fuel tank cpl. Réservoir de carburant cpl.		

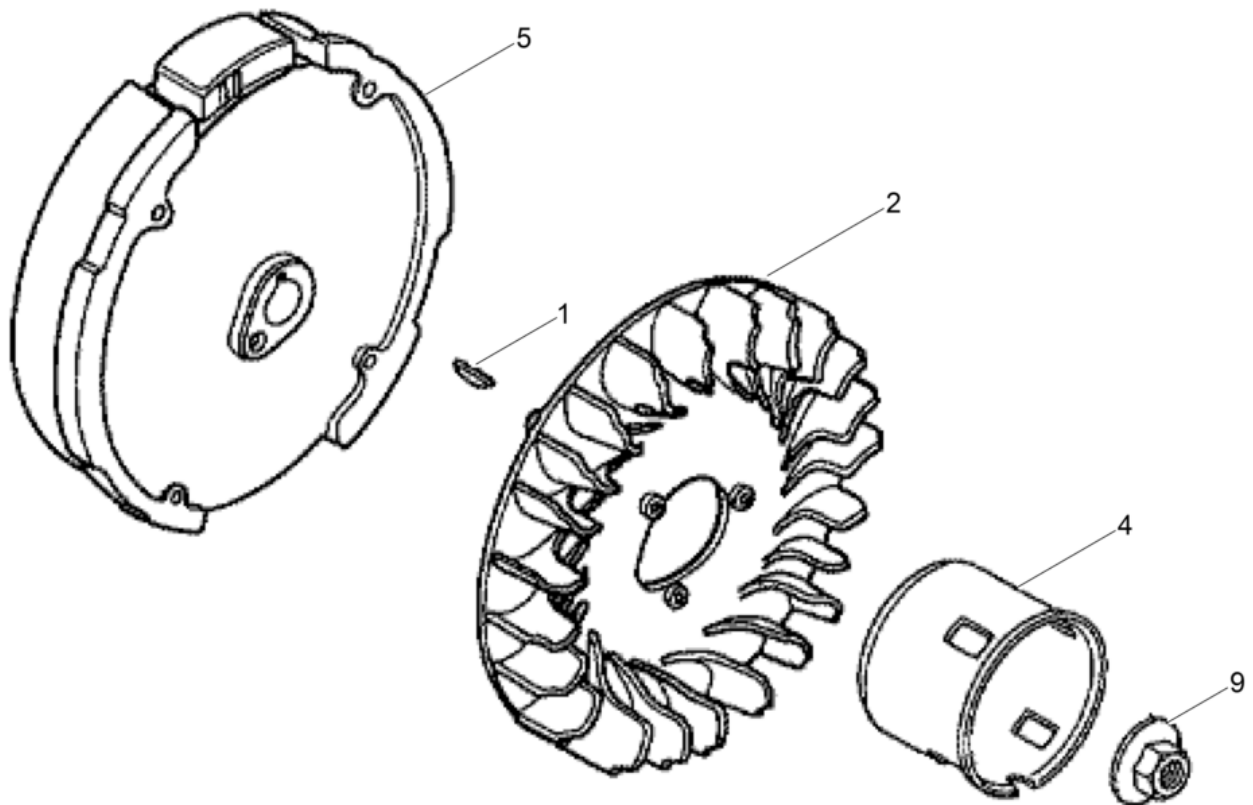

Pos. Ref.	Artikel Nr. Part No.	Qty.	Unit	Beschreibung Description	Description Description	Abm. Measur.	Norm Standard
						Drehm. Torque	Schmierstoff Sealant
1	5000068967	1	PC	Keil Chaveta woodruff	Woodruff key Clavette woodruff	25 x 18	
2	5000071652	1	PC	Lüfterrad Ventilador	Fan Ventilateur		
4	5000210396	1	PC	Seilcheibe Polea	Pulley Poulie		
5	5100005422	1	PC	Schwungrad Kpl. Volante cpl.	Fly wheel cpl. Volant cpl.		
9	5000162686	1	PC	Mutter Tuerca	Nut Écrou	M14	

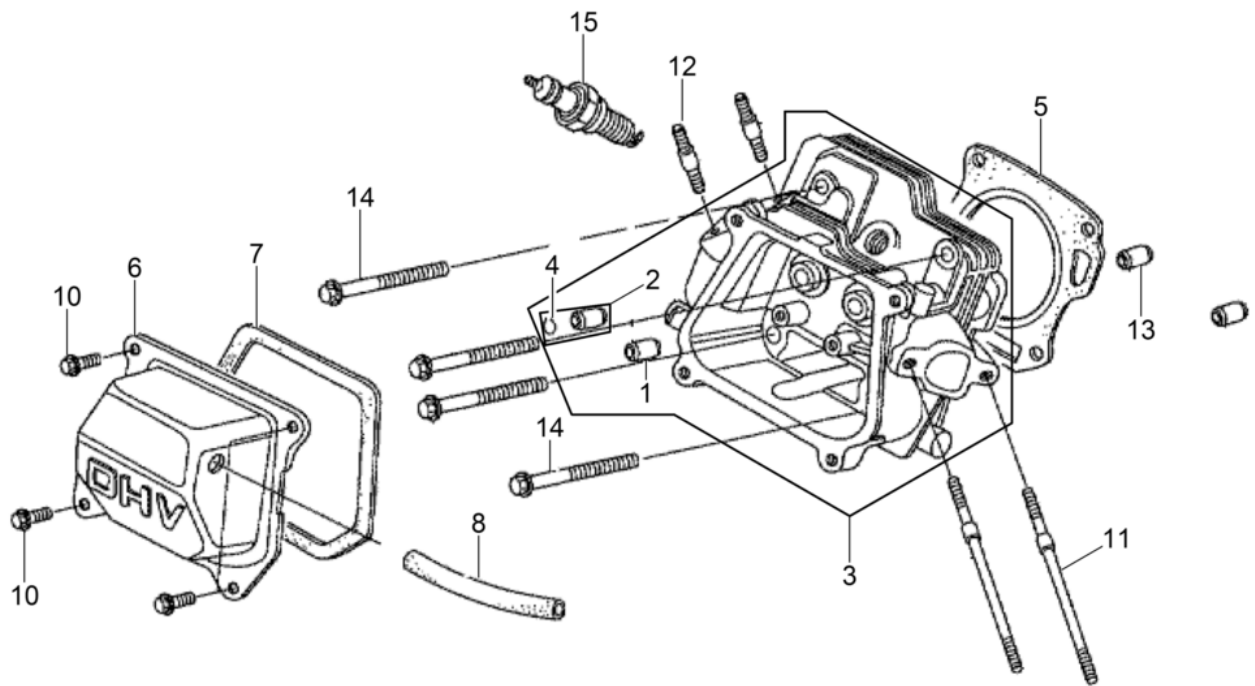

Pos. Ref.	Artikel Nr. Part No.	Qty.	Unit	Beschreibung Descripción	Description Description	Abm. Measur.	Norm Standard
						Drehm. Torque	Schmierstoff Sealant
1	5000070945	1	PC	Ventilführung Guía de válvula	Valve guide Guide de soupape		
2	5000070944	1	PC	Ventilführung Guía de válvula	Valve guide Guide de soupape		
3	5100005423	1	PC	Zylinderkopf Kpl. Culata cpl.	Cylinder head cpl. Culasse cpl.		
4	5000081744	1	PC	Sicherungring Anillo de retención	Retaining ring Bague d'arrêt		
5	5100005329	1	PC	Zylinderkopfdichtung Junta de culata del cilindro	Cylinder head gasket Joint de culasse de cylindre		
6	5100005424	1	PC	Deckel Kpl. Tapa cpl.	Cover cpl. Couvercle cpl.		
7	5000070942	1	PC	Dichtung Junta	Gasket Joint		
8	5000081761	1	PC	Entlüftungrohr Tubo respiradero	Breather tube Tube reniflard		
10	5000053990	4	PC	Schraube Tornillo	Screw Vis	M6 x 12 10Nm/7ft.lbs	
11	5000073263	2	PC	Gewindebolzen Perno prisionero	Stud Boulon	M6 x 109	
12	5000070948	2	PC	Gewindebolzen Perno prisionero	Stud Boulon	M8 x 32	
13	5000070950	2	PC	Patift Espiga	Dowel pin Cheville		
14	5000213398	4	PC	Flanchschraube Tornillo de brida	Flange screw Vis de bride	M 8x60	
15	5000150914	1	PC	Zündkerze Bujía	Spark plug Bougie		

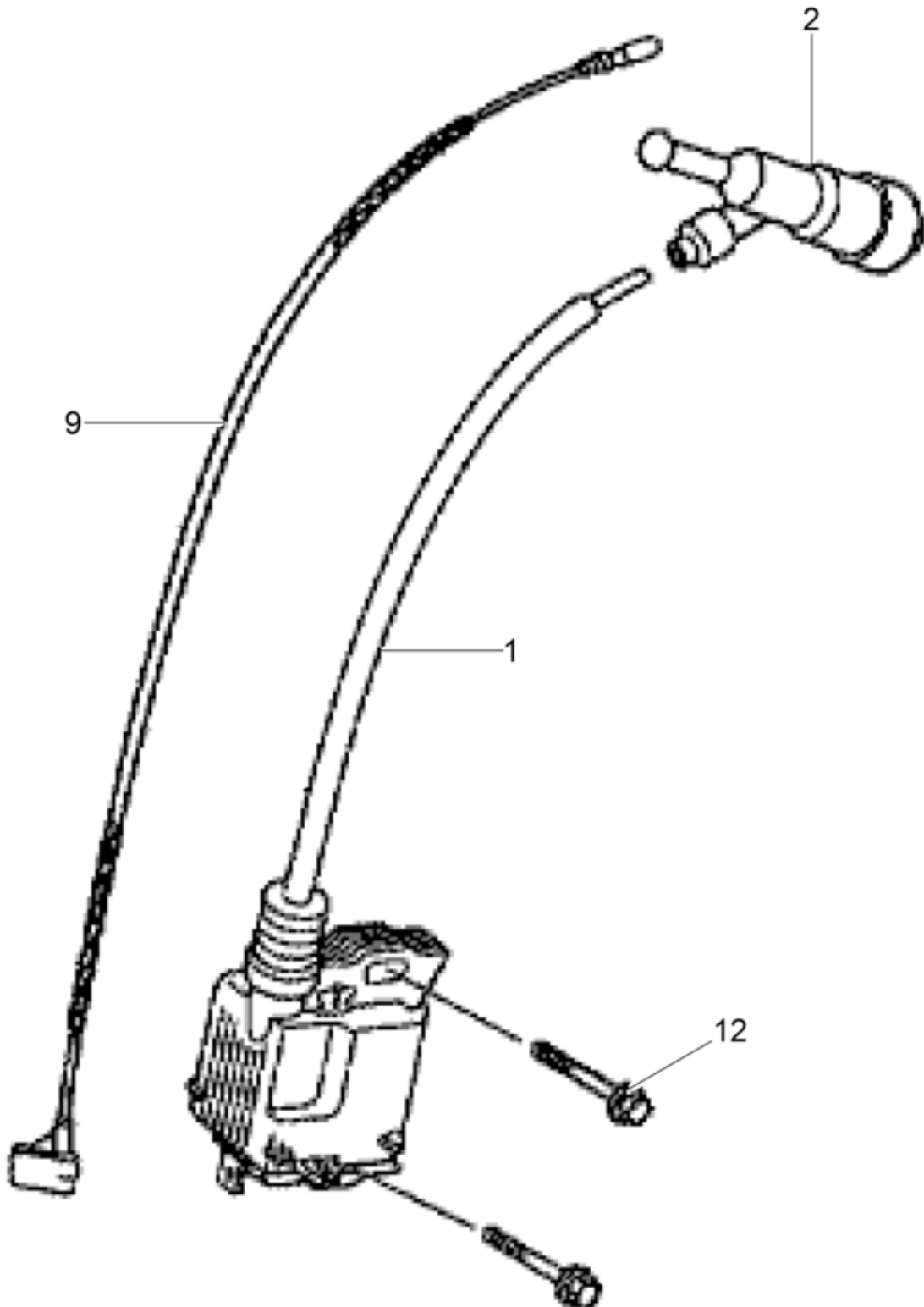

Pos. Ref.	Artikel Nr. Part No.	Qty.	Unit	Beschreibung Descripcion	Description Description	Abm. Measur.	Norm Standard
						Drehm. Torque	Schmierstoff Sealant
1	5100003455	1	PC	Zündpule Kpl. Bobina de encendido cpl.	Ignition coil cpl. Bobine d'allumage cpl.		
2	5000162680	1	PC	Zündkerzentecker Enchufe de bujía	Spark plug terminal cap Porte bougies		
9	5000081663	1	PC	Kurzschlusskabel Cable de cortocircuito	Short circuit cable Câble courti-circuit		
12	5000081737	2	PC	Schraube Tornillo	Screw Vis	M6 x 25	

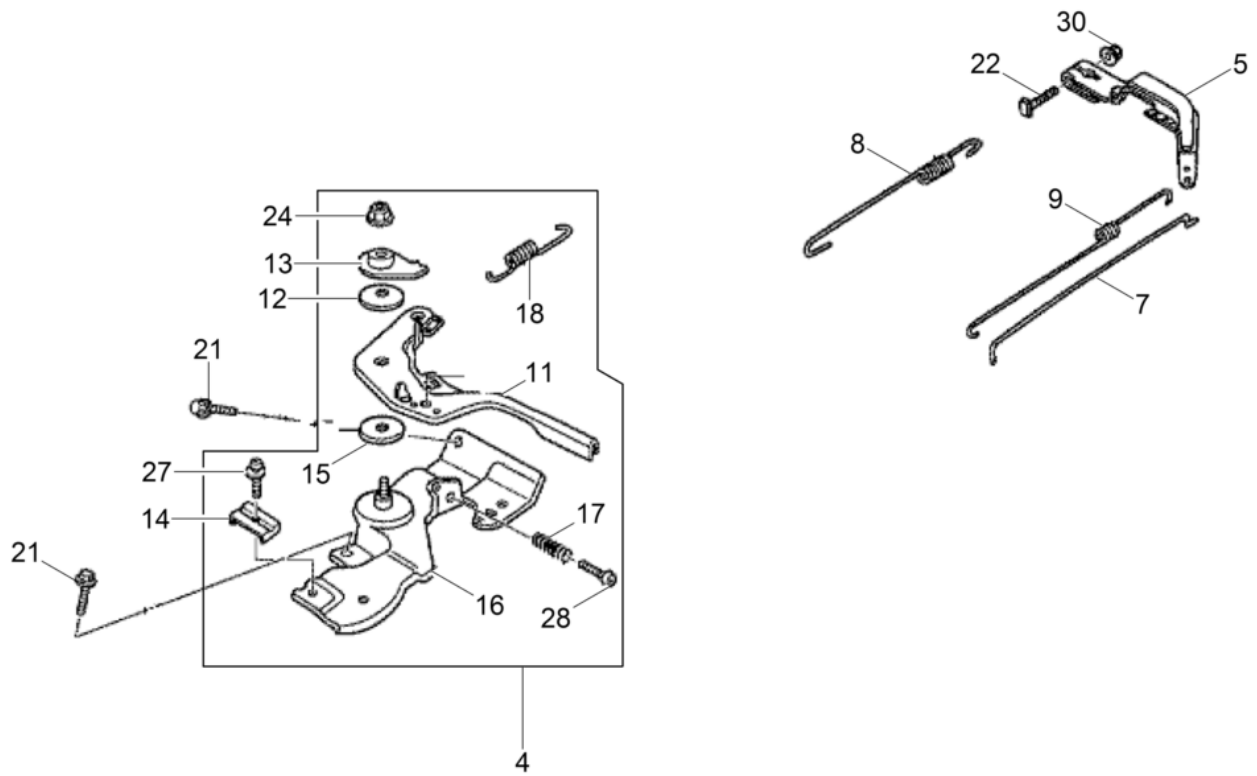

Pos. Ref.	Artikel Nr. Part No.	Qty.	Unit	Beschreibung Descripción	Description Description	Abm. Measur.	Norm Standard
						Drehm. Torque	Schmierstoff Sealant
4	5100009311	1	PC	Regler Kpl. US Regulador cpl. us	Governor cpl. us Régulateur cpl. us		
4	5100009312	1	PC	Regler Kpl. Regulador cpl.	Governor cpl. Régulateur cpl.		
5	5100005425	1	PC	Regulierhebel Palanca reguladora	Governor lever Levier régulateur		
7	5100005332	1	PC	Reglertange Varillaje de regulación	Governor rod Tige de régulateur		
8	5000406658	1	PC	Reglerfeder Resorte del regulador	Governor spring Ressort régulateur		
9	5100005427	1	PC	Rückholfeder Resorte de retorno	Return spring Ressort de rappel		
11	5100005333	1	PC	Reglerhebel Palanca de regulador	Governor lever Levier régulateur		
12	5000071058	1	PC	Feder Resorte	Spring Ressort		
13	5000071057	1	PC	Scheibe Arandela	Washer Rondelle		
14	5000071062	1	PC	Klemme Soporte cable	Cable holder Attache		
15	5000071064	1	PC	Ditanzstück Espaciador	Spacer Pièce d'écartement		
16	5100005363	1	PC	Halterung Kpl. Soporte cpl.	Bracket cpl. Équerre cpl.		
17	5000054088	1	PC	Feder Resorte de ajuste	Adjusting spring Ressort d'ajustage		
18	5000071667	1	PC	Feder Resorte	Spring Ressort		
21	5000053990	2	PC	Schraube Tornillo	Screw Vis	M6 x 12 10Nm/7ft.lbs	
22	5000068966	1	PC	Schraube Tornillo	Screw Vis		
24	5000072782	1	PC	Sicherungsmutter Contratuerca	Locknut Contre-écrou	M6	
27	5000110112	1	PC	Schraube Tornillo	Screw Vis	5 x 16	
28	5000081990	1	PC	Schraube Tornillo	Screw Vis	M5 x 25	
30	5000071056	1	PC	Mutter Tuerca	Nut Ecrou	M6	

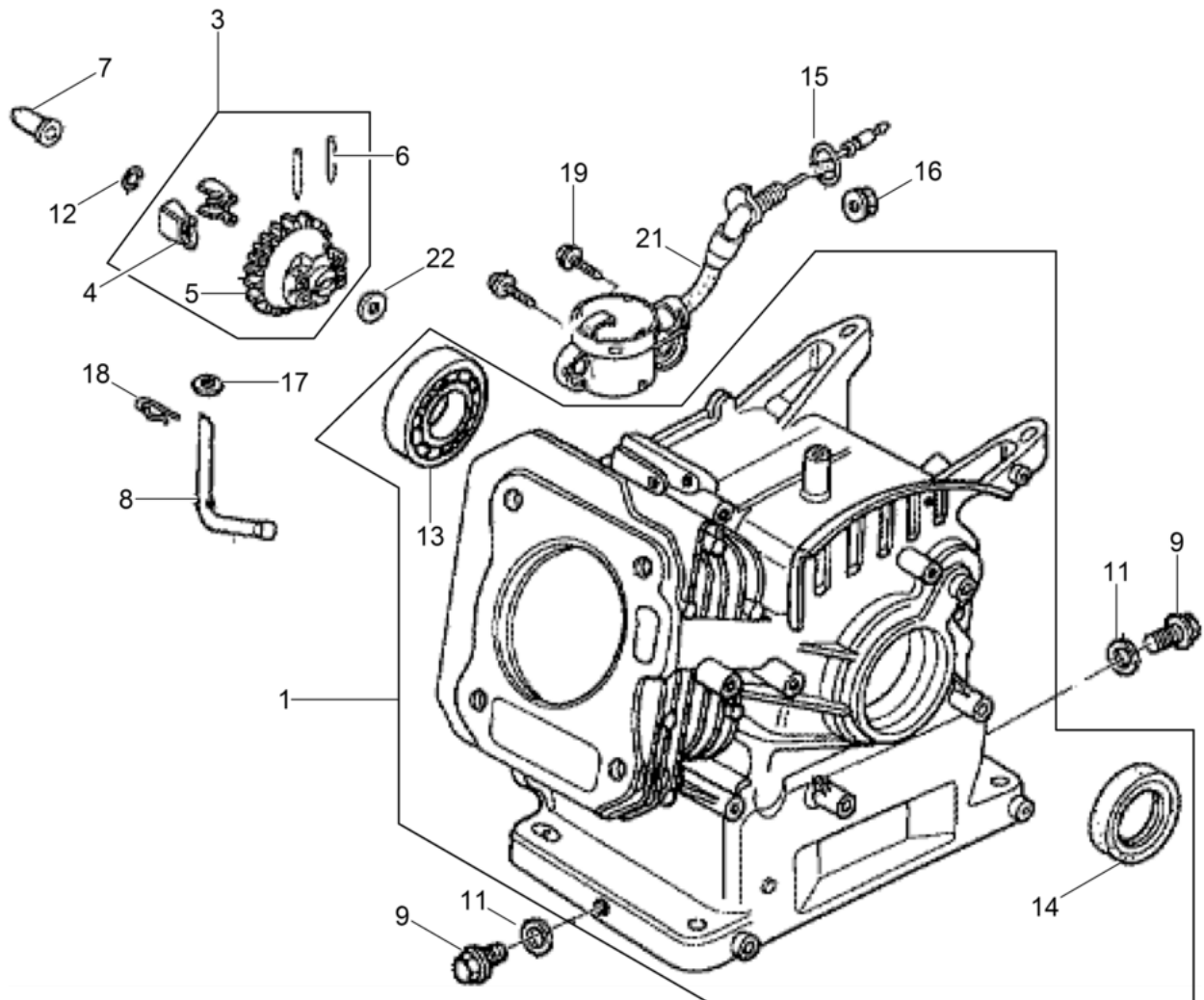

Pos. Ref.	Artikel Nr. Part No.	Qty.	Unit	Beschreibung Descripción	Description Description	Abm. Measur.	Norm Standard
						Drehm. Torque	Schmierstoff Sealant
1	5200006492	1	PC	Zylinder Kpl. Cilindro compl.	Cylinder cpl. Cylindre compl.		
3	5100005429	1	PC	Regler Kpl. Regulador cpl.	Governor cpl. Régulateur cpl.		
4	5100005430	2	PC	Gewicht Peso	Weight Poids		
5	5100005431	1	PC	Halter Soporte	Bracket Équerre		
6	5000156689	2	PC	Stift Espiga	Pin Goupille		
7	5100005432	1	PC	Reglertift Pasador del regulador	Governor pin Pointe de regulateur		
8	5100005433	1	PC	Regler Regulador	Governor Régulateur		
9	5000070964	2	PC	Verchlußschraube Tapón roscado	Plug (threaded) Bouchon		
11	5000070963	2	PC	Scheibe Arandela	Washer Rondelle		
12	5000081615	1	PC	Sicherungring Anillo de retención	Retaining ring Bague d'arrêt		
13	5000082018	1	PC	Lager Rodamiento	Bearing Roulement		
14	5000217464	1	PC	Wellendichtring Empaque de aceite	Oil seal Joint d'huile	25x41x6	
15	5000208616	1	PC	O-Ring Anillo-o	O-ring Joint torique	14M	
16	5000072332	1	PC	Flanchmutter Tuerca de reborde	Flange nut Ecrou de bride	M10	
17	5000071639	1	PC	Scheibe Arandela	Washer Rondelle	6M	
18	5000054033	1	PC	Stift Pasador	Pin Goupille		
19	5100003498	2	PC	Flanchschraube 6X12 Tornillo de brida	Flange screw Vis de bride	6x12	
21	5000216513	1	PC	Ölwarnhalter Modulo-interruptor	Oil alert switch cpl. Module-contacteur		
22	5000071639	1	PC	Scheibe Arandela	Washer Rondelle	6M	

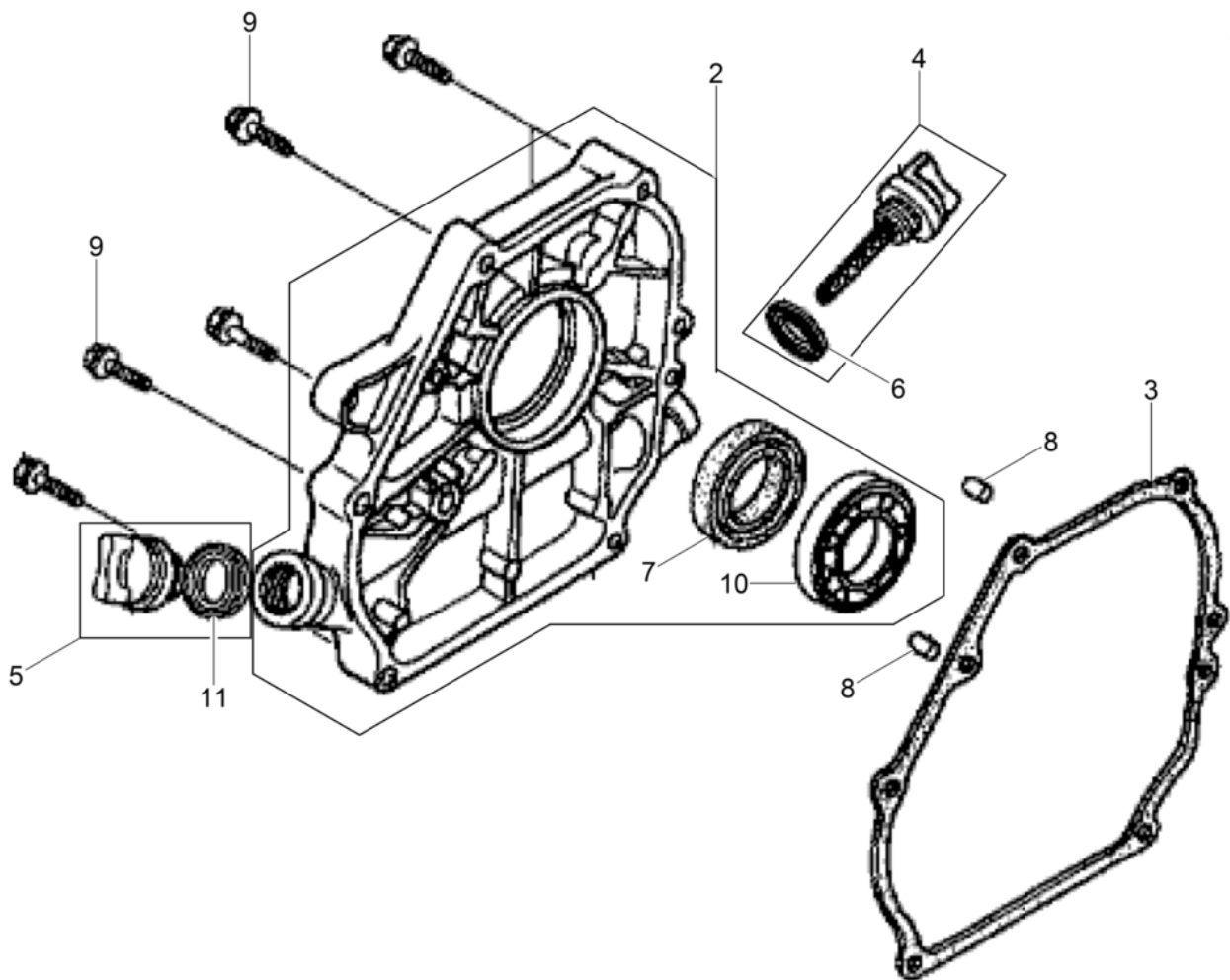

Pos. Ref.	Artikel Nr. Part No.	Qty.	Unit	Beschreibung Description	Description Description	Abm. Measur.	Norm Standard
						Drehm. Torque	Schmierstoff Sealant
2	5100005434	1	PC	Kurbelgehäusedeckel Kpl. Tapa del cárter cpl.	Crankcase cover cpl. Couvercle de carter cpl.		
3	5100009314	1	PC	Dichtung Junta	Gasket Joint		
4	5000162645	1	PC	Peiltab Kpl. Indicador del nivel de aceite compl.	Dipstick assembly Réglette-jauge compl.		
5	5000162646	1	PC	Kappe-Ölfüller Llenador de aceite	Oil filler cap Remplisseur d'huile		
6	5000162647	1	PC	Dichtung Junta de estanqueidad	Gasket Garniture		
7	5000053983	1	PC	Wellendichtring Sello del eje	Shaft seal Bague d'étanchéité		
8	5000053995	2	PC	Patift Espiga	Dowel pin Cheville	A8 x 14	
9	5100003504	6	PC	Flanchschraube 8X32 Tornillo de brida	Flange screw Vis de bride	8x32	
10	5100003510	1	PC	Radialkugellager 6205 Rodamiento de bolas	Grooved ball bearing Roulement à billes		
11	5000162647	1	PC	Dichtung Junta de estanqueidad	Gasket Garniture		

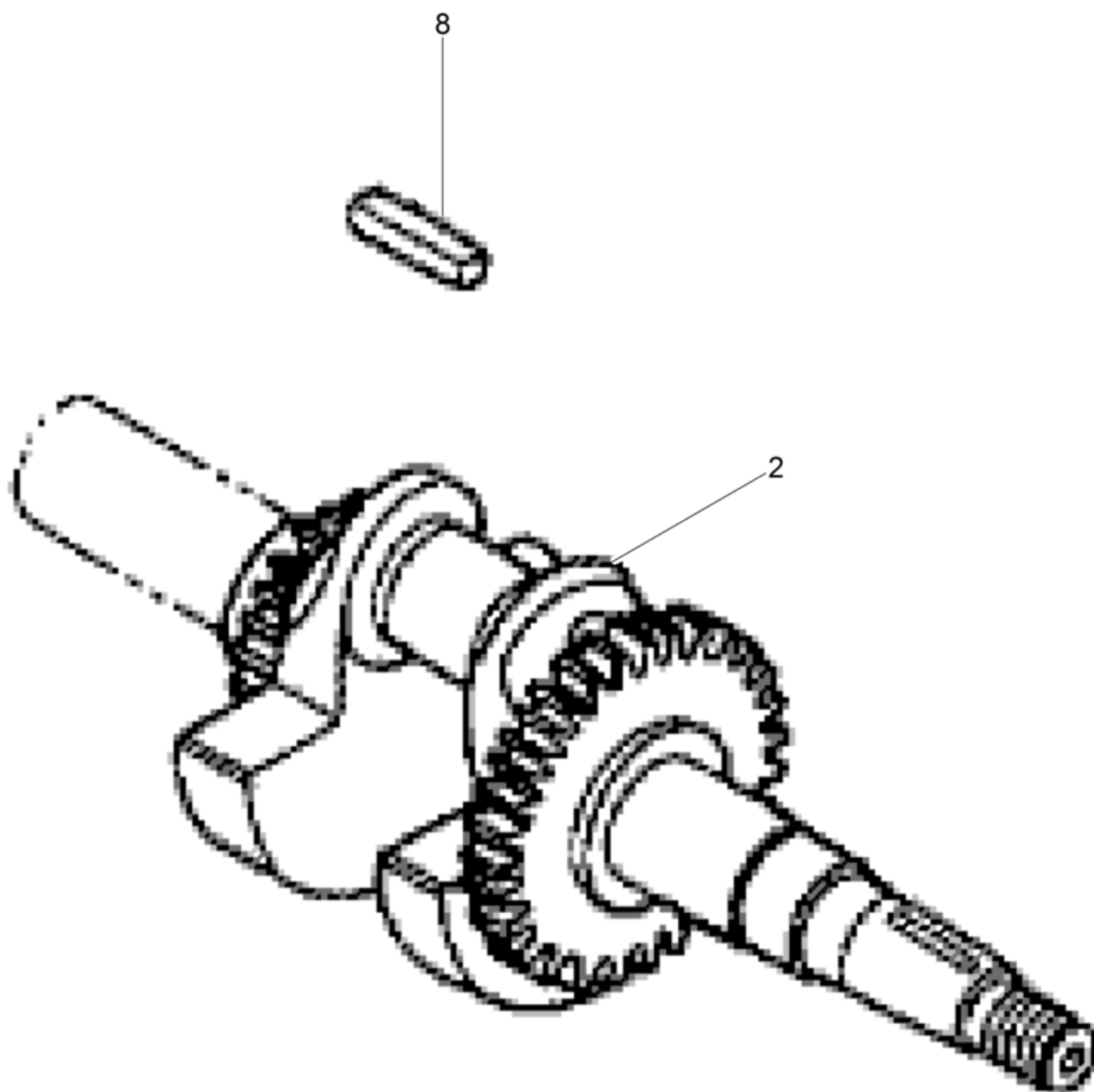

Pos. Ref.	Artikel Nr. Part No.	Qty.	Unit	Beschreibung Descripcion	Description Description	Abm. Measuram.	Norm Standard
						Drehm. Torque	Schmierstoff Sealant
2	5100005359	1	PC	Kurbelwelle Kpl. Cigueñal cpl.	Crankshaft cpl. Vilebrequin cpl.		
2	5000217529	1	PC	Radialkugellager Rodamiento a bolas	Ball bearing Roulement à billes		
2	5100003485	1	PC	Radialkugellager 6205 Rodamiento de bolas	Grooved ball bearing Roulement à billes		
8	5000070999	1	PC	Pafeder Chaveta	Fitting key Clavette	4,78 x 38	

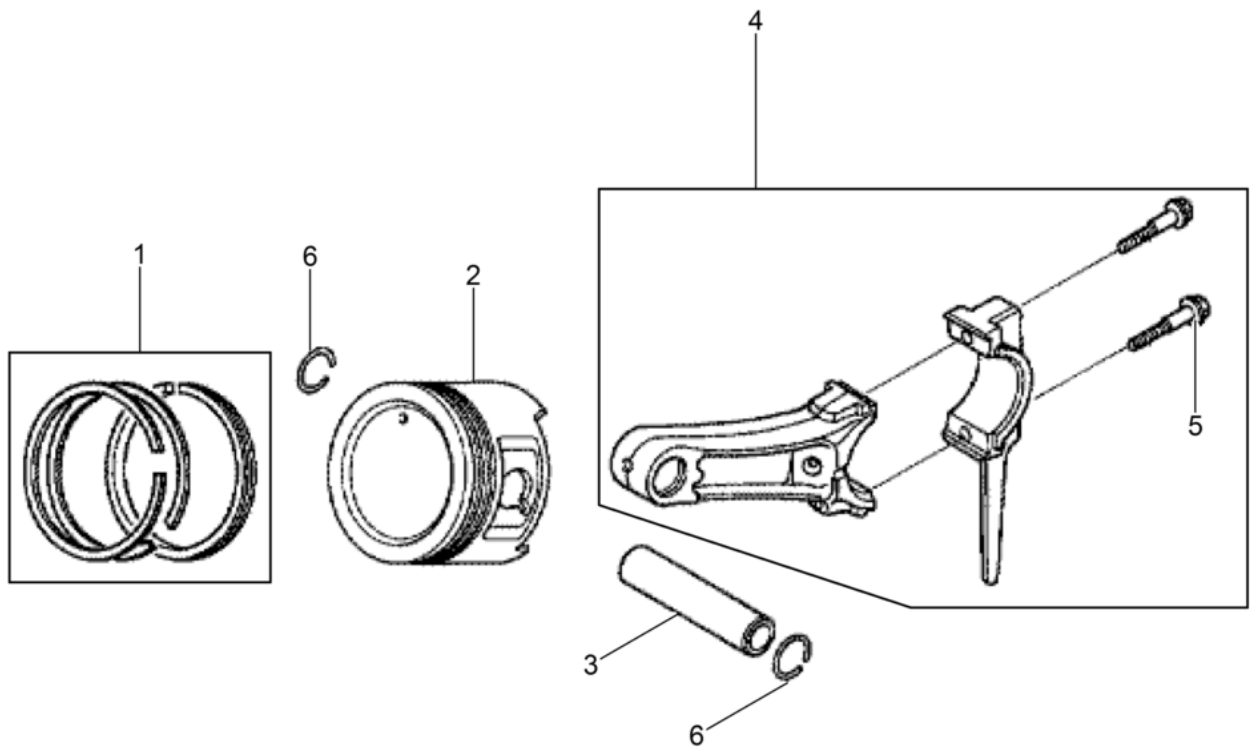

Pos. Ref.	Artikel Nr. Part No.	Qty.	Unit	Beschreibung Descripción	Description Description	Abm. Measur.	Norm Standard
						Drehm. Torque	Schmierstoff Sealant
1	5100005355	1	PC	Kolbenringatz Juego de aros de pistón	Set of piston rings Jeu de bagues de piston		
1	5100005435	1	PC	Kolbenringatz Juego de aros de pistón	Set of piston rings Jeu de segments de piston		
1	5000213334	1	PC	Kolbenringatz Juego de anillos	Piston ring set Jeu de segments	+0,25 mm	
1	5000213335	1	PC	Kolbenringatz Juego de anillos	Piston ring set Jeu de segments	+0,50 mm	
2	5100005436	1	PC	Kolben Pistón	Piston Piston		
2	5100019661	1	PC	Kolben Pistón	Piston Piston	0,25	
2	5100019662	1	PC	Kolben Pistón	Piston Piston	0,50	
3	5100005348	1	PC	Kolbenbolzen Perno de pistón	Piston pin Axe de piston		
4	5200006505	1	PC	Pleuel Kpl. Biela compl.	Connecting rod cpl. Bielle compl.		
5	5100005438	2	PC	Schraube Tornillo	Screw Vis	6x34,4	
6	5000081994	2	PC	Drahtprengring Anillo de retención	Retaining ring Anneau de retenue		

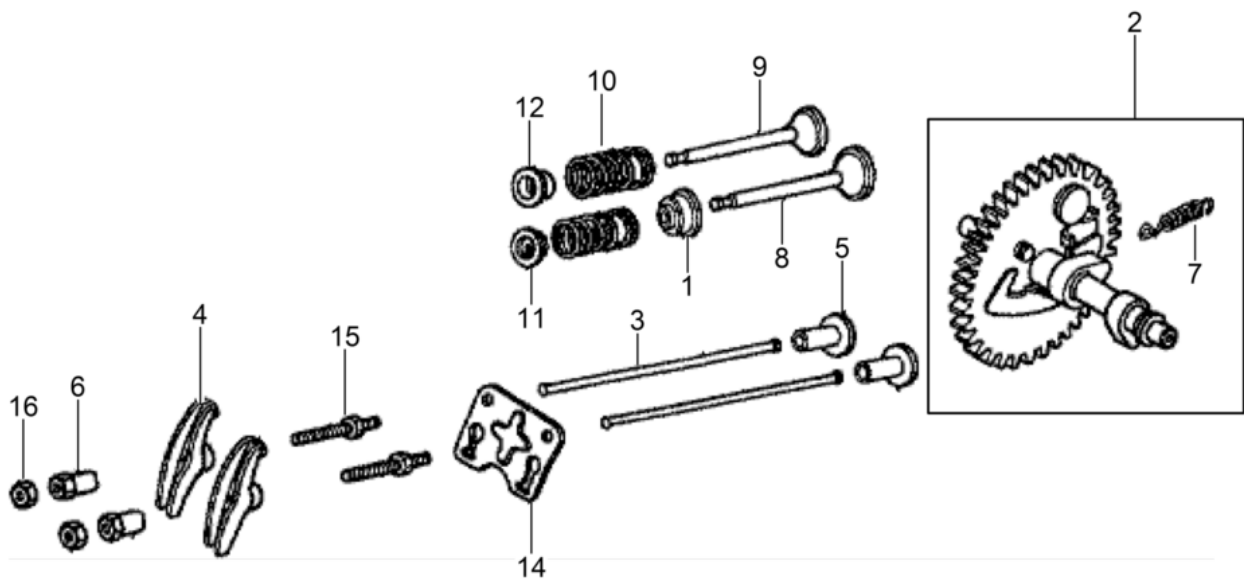

Pos. Ref.	Artikel Nr. Part No.	Qty.	Unit	Beschreibung Descripción	Description Description	Abm. Measur.	Norm Standard
						Drehm. Torque	Schmierstoff Sealant
1	5100005349	1	PC	Dichtung Junta	Gasket Joint		
2	5100005439	1	PC	Nockenwelle Kpl. Arbol de levas cpl.	Camshaft cpl. Arbre à cames cpl.		
3	5100005440	2	PC	Schubtange Varilla de empuje	Push rod Pousoir		
4	5000070986	2	PC	Kipphebel Balancín	Rocker arm Culbuteur		
5	5000070990	2	PC	Ventiltößel Levantaválvula	Valve tappet Pousoir		
6	5000070985	2	PC	Einstellmutter Espaciador	Rocker arm pivot Pivot		
7	5000151028	1	PC	Feder Resorte	Spring Ressort		
8	5100005441	1	PC	Einlaiventil Válvula de admisión	Intake valve Soupape d'admission		
9	5100005442	1	PC	Aulaiventil Válvula de escape	Outlet valve Soupape d'échappement		
10	5000081760	2	PC	Feder Resorte	Spring Ressort		
11	5000070996	1	PC	Halte Soporte	Holder Attache		
12	5000070996	1	PC	Halte Soporte	Holder Attache		
14	5100005443	1	PC	Führungblech Chapa de guía	Guide plate Tôle de guidage		
15	5000072778	2	PC	Gewindebolzen Perno prisionero	Stud Boulon	8	
16	5000070984	2	PC	Sechskantmutter Contratuerca	Locknut Contre-écrou	1/4-28in	



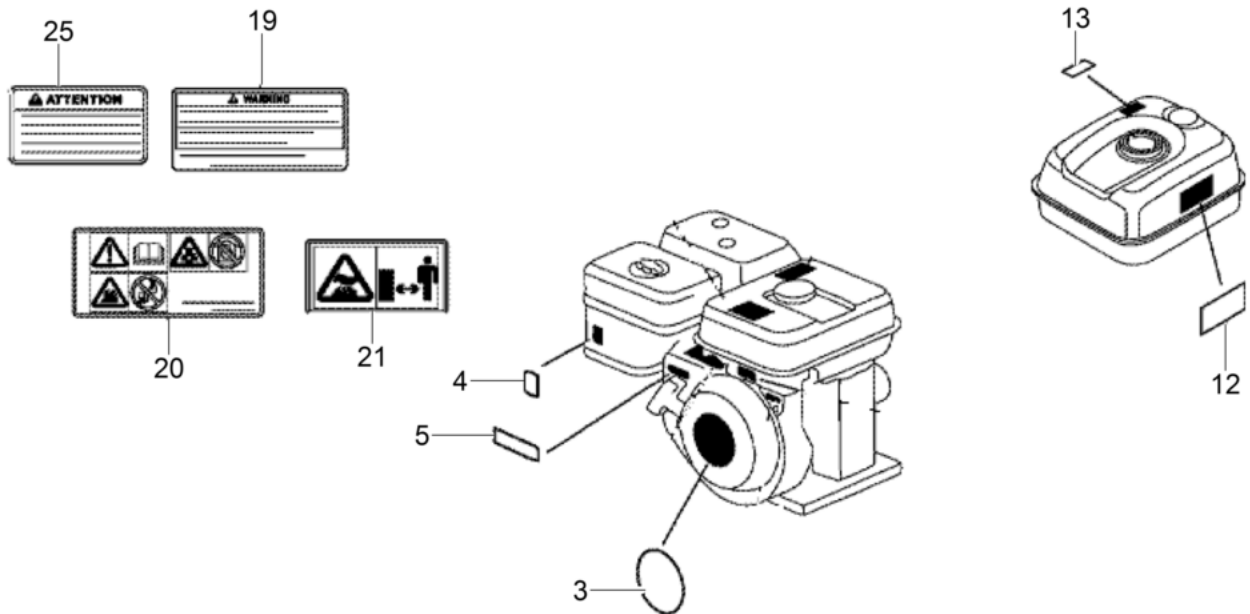

Pos. Ref.	Artikel Nr. Part No.	Qty.	Unit	Beschreibung Descripcion	Description Description	Abm. Measur.	Norm Standard
						Drehm. Torque	Schmierstoff Sealant
3	5100005352	1	PC	Aufkleber GX160 Calcomanía gx160	Label gx160 Autocollant gx160		
4	5100005336	1	PC	Aufkleber Calcomanía	Label Autocollant		
5	5000208623	1	PC	Aufkleber Calcomanias	Labels Autocollants		
12	5100000437	1	PC	Warnhinweiß Etiqueta amonestadora	Warning label Étiquette d'avertissement		
13	5100005337	1	PC	Aufkleber Calcomanía	Label Autocollant		
19	5100000438	1	PC	Warnhinweiß Etiqueta amonestadora	Warning label Étiquette d'avertissement		
20	5100000439	1	PC	Warnhinweiß Etiqueta amonestadora	Warning label Étiquette d'avertissement		
22	5100005340	1	PC	Aufkleber Calcomanía	Label Autocollant		
25	5100005339	1	PC	Aufkleber Calcomanía	Label Autocollant		

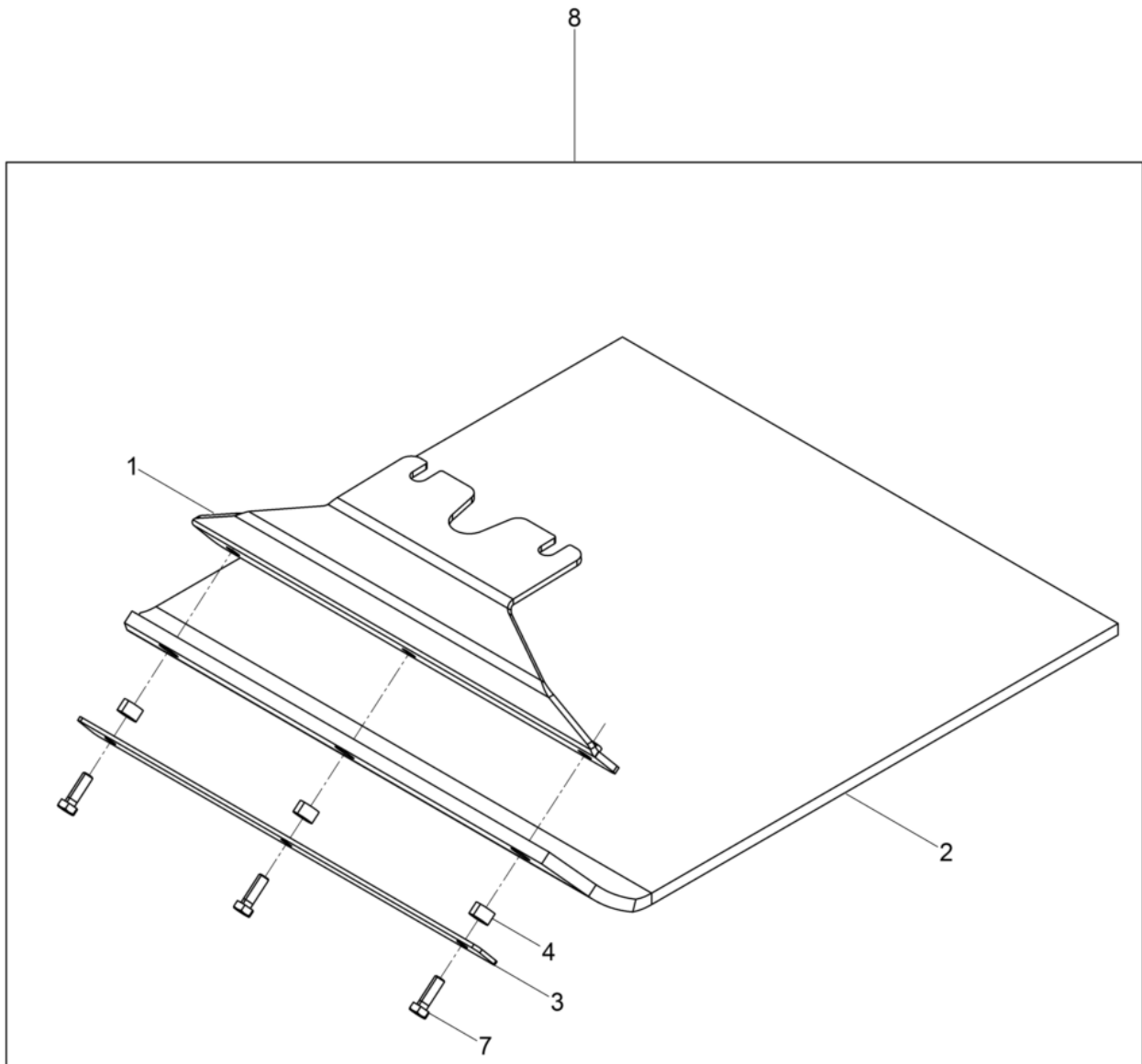

Pos. Ref.	Artikel Nr. Part No.	Qty.	Unit	Beschreibung Descripcion	Description Description	Abm. Measuram.	Norm Standard
						Drehm. Torque	Schmierstoff Sealant
1	5100016464	1	PC	Winkel Kpl. Ángulo cpl.	Angle cpl. Coude cpl.		
2	5100016466	1	PC	Kunttloffplatte Juego de lamina de uretano	Urethane plate Dispositif de glissement		
3	5100016467	1	PC	Blech Chapa	Plate Tôle		
4	5100017122	3	PC	Buche Buje	Bush Boîte		
7	5000011457	3	PC	Sechskantchraube Tornillo hexagonal	Hexagonal head cap screw Vis à tête hexagonale	M8 x 25 25Nm/18ft.lbs	
8	5100016463	1	PC	Gleitvorrichtung PGV 1550 Placa de deslizamiento pgv 1550	Urethane pad kit pgv 1550 Jeu de tapis en polyuréthane		



Trolley cpl.
Dispositivo de transporte cpl.
Chassis cpl.
Fahrgetell Kpl.

WP1550A

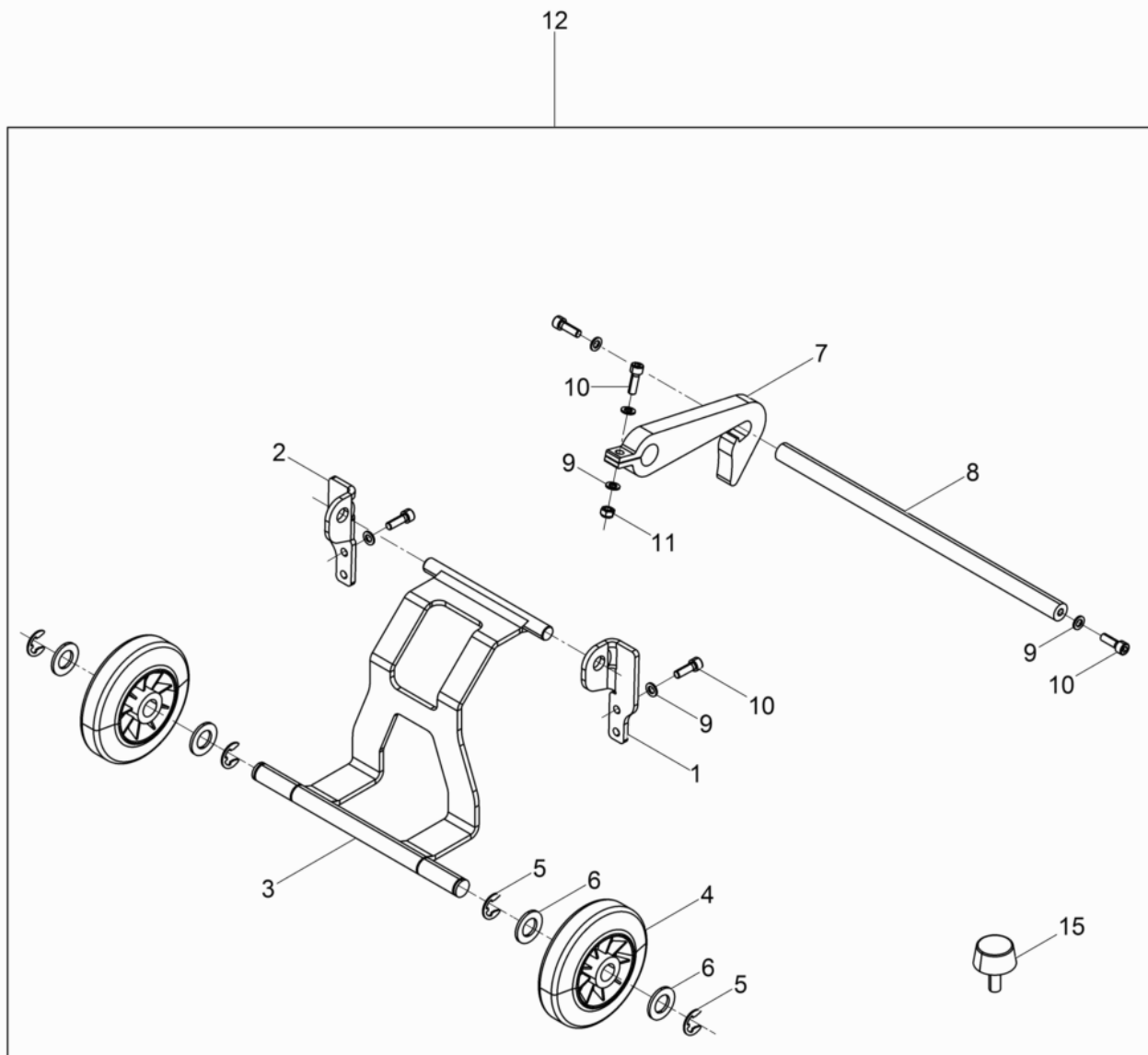

Pos. Ref.	Artikel Nr. Part No.	Qty.	Unit	Beschreibung Descripcion	Description Description	Abm. Measur.	Norm Standard
						Drehm. Torque	Schmierstoff Sealant
1	5100016472	1	PC	Halter Soporte	Bracket Support		
2	5100016471	1	PC	Halter Soporte	Bracket Support		
3	5100016469	1	PC	Fahrgetell Dispositivo de transporte	Trolley Chassis		
4	5000021466	2	PC	Rad Rueda	Tire Roue	140 x 37,5	
5	5000103834	4	PC	Sicherungscheibe Arandela de seguridad	Lock washer Rondelle d'arrêt	15	DIN6799
6	5000010616	4	PC	Scheibe Arandela	Flat washer Rondelle		
7	5100016474	1	PC	Haken Gancho	Hook Crochet		
8	5100018310	1	PC	Strebe Puntual	Brace Contre-fiche		
9	5000010742	8	PC	Scheibe Arandela	Washer Rondelle		
10	5000011542	7	PC	Zylinderchraube Tornillo cilíndrico	Cheese head screw Vis à tête cylindrique	25Nm/18ft.lbs	
11	5000033356	1	PC	Sechskantmutter Tuerca hexagonal	Hexagon nut Écrou hexagonal		
12	5100016468	1	PC	Fahrgetell Kpl. Dispositivo de transporte cpl.	Trolley cpl. Chassis cpl.		
15	5100016317	2	PC	Anschlagpuffer Amortiguador	Shockmount Silentbloc	30 x 15	

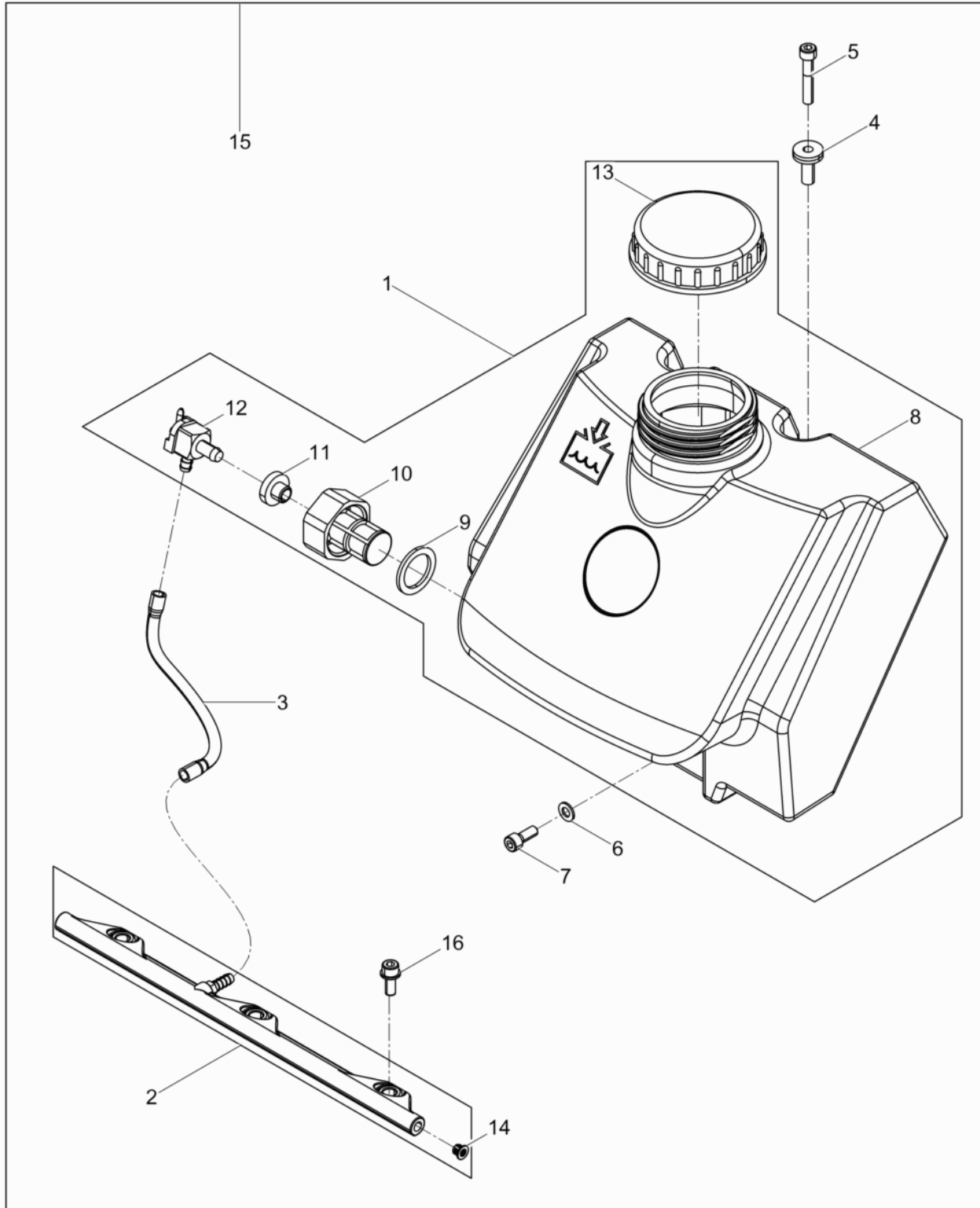

Pos. Ref.	Artikel Nr. Part No.	Qty.	Unit	Beschreibung Description	Description Description	Abm. Measur.	Norm Standard
						Drehm. Torque	Schmierstoff Sealant
1	5100028975	1	PC	Waertank Kpl. Tanque de agua cpl.	Water tank cpl. Reservoir à eau cpl.		
2	5100028977	1	PC	Berie lung Kpl. Sistema de riego cpl.	Spinkler system cpl. Installation d'arrosage cpl.		
3	5100028939	1	PC	Waerchlauch Manguera de agua	Water hose Tuyau d'eau		
4	5100016451	2	PC	Ditanzhüle Manguito distanciador	Spacer sleeve Douille d'écartement		
5	5000011538	2	PC	Zylinderchraube Tornillo cilíndrico	Cheese head screw Vis à tête cylindrique	M8 x 45 25Nm/18ft.lbs	ISO4762
6	5000010622	2	PC	Scheibe Arandela	Flat washer Rondelle		
7	5000011543	2	PC	Zylinderchraube Tornillo hueco	Socket head screw Vis à six-pans creux	M8 x 20 24Nm/18ft.lbs	ISO4762
8	5100028976	1	PC	Waertank Tanque de agua	Watertank Reservoir à eau		
9	5100028934	1	PC	Dichtungring Anillo sellador	Ring seal Rondelle à étancher		
10	5100028935	1	PC	Waerfilter Filtro de agua	Water filter Filtre à eau		
11	5000053577	1	PC	Tankbuche Buje	Tank valve bushing Douille		
12	5100028937	1	PC	Abperrventil Válvula de cierre	Shut-off valve Robinet d'arrêt		
13	5000068351	1	PC	Schraubdeckel Tapa roscable	Screwed cover Couvercle fileté		
14	5100027000	2	PC	Einraubtopfen Tapón	Plug (threaded) Bouchon		
15	5100028981	1	PC	Berie lung Kpl. Sistema de riego cpl.	Sprinkler system cpl Installation d'arrosage cpl.		
16	5100042618	3	PC	Zylinderchraube Tornillo cilíndrico	Cheese head screw Vis à tête cylindrique		

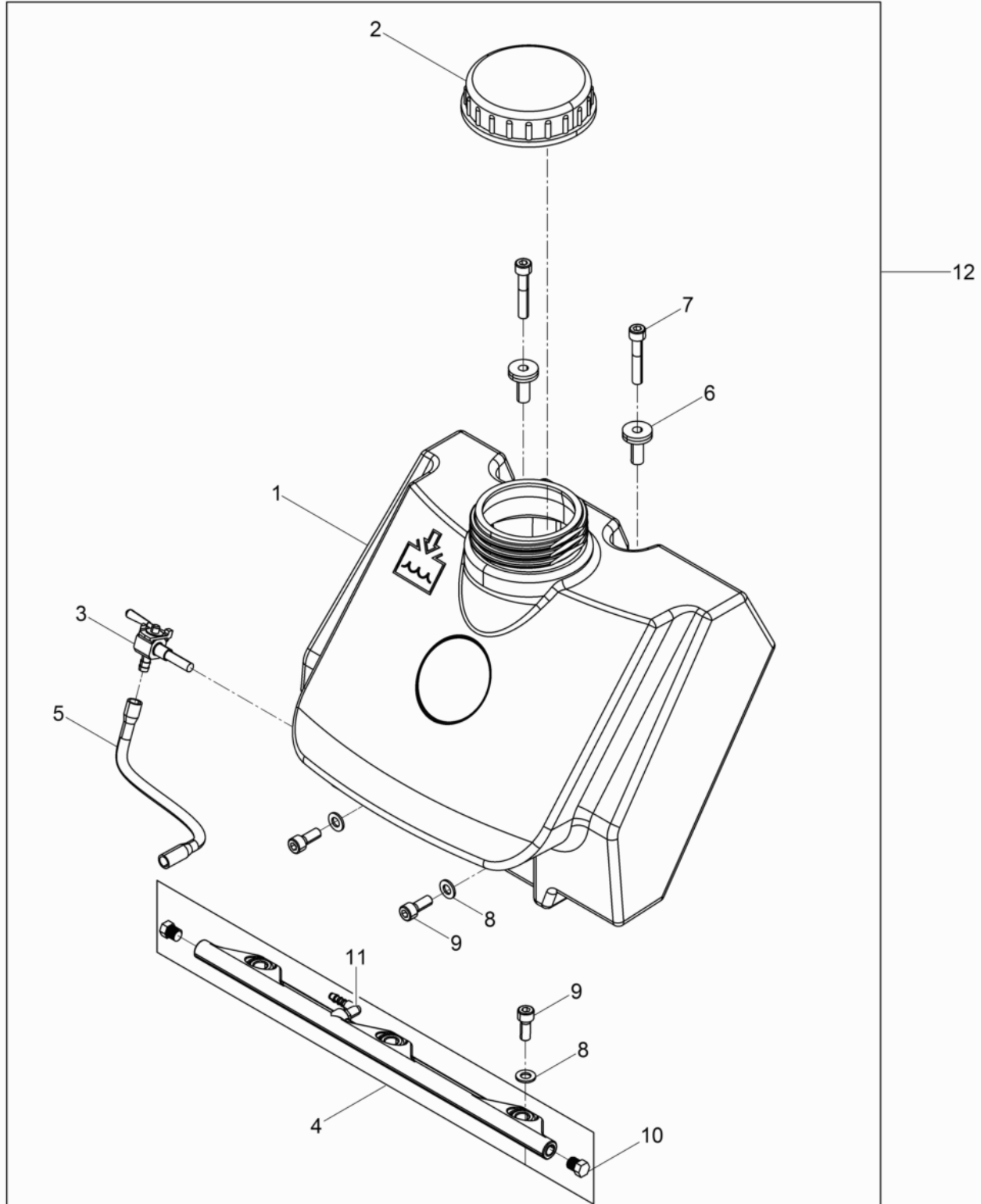

Pos. Ref.	Artikel Nr. Part No.	Qty.	Unit	Beschreibung Descripcion	Description Description	Abm. Measuram.	Norm Standard
						Drehm. Torque	Schmierstoff Sealant
1	5100016315	1	PC	Waertank Tanque de agua	Water tank Reservoir à eau		
2	5000068351	1	PC	Schraubdeckel Tapa roscable	Screwed cover Couvercle fileté		
3	5100016618	1	PC	Waerhahn Grifo	Shutoff valve Robinet		
4	5100021918	1	PC	Berieelung Kpl. Systema de riego cpl.	Spinkler system cpl. Installation d'arrosage cpl.		
5	5100018315	1	PC	Waerchlauch Manguera de agua	Water hose Tuyau d'eau	6x1,5x266 mm	
6	5100016451	2	PC	Ditanzhüle Manguito distanciador	Spacer sleeve Douille d'écartement		
7	5000011538	2	PC	Zylinderchraube Tornillo cilíndrico	Cheese head screw Vis à tête cylindrique	M8 x 45 25Nm/18ft.lbs	ISO4762
8	5000010622	5	PC	Scheibe Arandela	Flat washer Rondelle		
9	5000011543	5	PC	Zylinderchraube Tornillo hueco	Socket head screw Vis à six-pans creux	M8 x 20 24Nm/18ft.lbs	ISO4762
10	5100027000	2	PC	Einraubtopfen Tapón	Plug (threaded) Bouchon		
11	5100021610	1	PC	Winkeleinraubtutzen Atornilladura angulara	Hose fitting Manchon visse	No. 6 x 1/8in NPT x 90	
12	5100026163	1	PC	Berieelung Kpl. Systema de riego cpl.	Spinkler system cpl. Installation d'arrosage cpl.		



**WACKER
NEUSON**

