



**WACKER
NEUSON**

Ersatzteilkatalog
Spare parts list
Catalogo de piezas de repuesto
Catalogue des pièces détachées

Vibrationsplatte
Vibratory plate
Plancha vibratoria
Plaque vibrante

DPU6555HEC



Type	DPU6555HEC
Material Number	5100016944
Version	104
Language	de en es fr



www.wackerneuson.com

Copyright © 03.2019
Wacker Neuson Produktion GmbH & Co. KG
Printed in Germany.
All rights reserved.

Ein Typenschild mit Typ, Artikelnummer, Version und Maschinen-Nummer ist an jedem Gerät angebracht. Die Daten von diesem Schild bitte notieren, damit sie auch bei Verlust oder Beschädigung des Schildes noch vorhanden sind. Der Typ, die Artikelnummer, die Versions-Nummer und die Maschinen-Nummer sind bei der Ersatzteilbestellung oder Nachfragen bezüglich Service-Informationen stets erforderlich.

Bei den in den Ersatzteillisten fettgedruckten Nummern handelt es sich um empfohlene Ersatzteile. Dies bedeutet, daß diese Teile bei normalen Anwendungsbedingungen natürlicher Abnutzung ausgesetzt sind und gelegentlich ersetzt oder überarbeitet werden müssen. Es wird geraten, diese Teile auf Lager bereit zu haben, um für Service-Arbeiten an diesem Gerät vorbereitet zu sein. Lagerbestände für diese und andere Teile, welche für ausgiebigere Reparaturarbeiten benötigt werden, können je nach Service-Gewohnheiten der einzelnen Kunden variieren.

Die Nummern meines Gerätes sind:

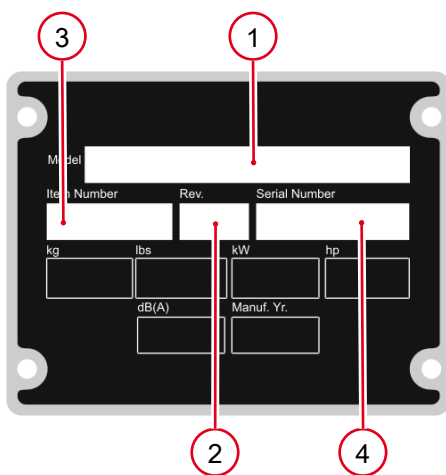

1. Typ
2. Version
3. Artikel-Nr.
4. Maschinen-Nr.

Umrechnungstabelle

Volumeneinheit	
1 ml	0.034 US fl.oz.
1 l	0.260 gal
Längeneinheit	
1 mm	0.039 in
1 m	3.280 ft
Gewicht	
1 kg	2.200 lbs
1 g	0.035 oz
Geschwindigkeit	
1 km/h	0.620 mph
Drehmoment	
1 Nm	0.740 ft.lbs

A nameplate listing the Model Number, Item Number, Revision, and Serial Number is attached to each unit. Please record the information found on this plate so it will be available should the nameplate become lost or damaged. When ordering parts or requesting service information, you will always be asked to specify the model, item number, revision number, and serial number of the unit.

Part Numbers appearing in boldface type are recommended spare parts. This means that these parts are subject to wear under normal operating conditions and may require periodic service or replacement. It is recommended that these items be stocked to meet the expected service requirements of this model. Actual stocking quantities of these and other parts used in more extensive repairs will depend on the service practices of each customer.

My machine's numbers are:

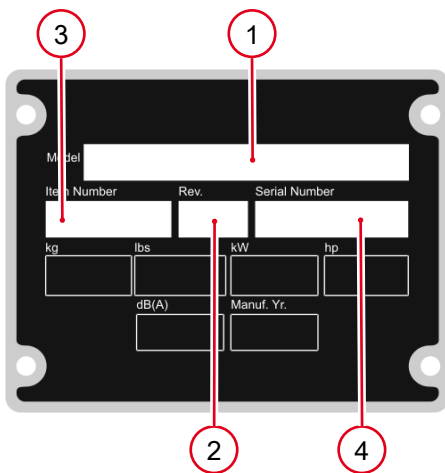

1. Model
2. Revision
3. Item No.
4. Serial No.

Conversion table

Volume unit	
1 ml	0.034 US fl.oz.
1 l	0.260 gal
Unit of length	
1 mm	0.039 in
1 m	3.280 ft
Weight	
1 kg	2.200 lbs
1 g	0.035 oz
Speed	
1 km/h	0.620 mph
Torque	
1 Nm	0.740 ft.lbs

Una placa de identificación con el modelo, número de referencia, nivel de revisión y número de serie ha sido añadida en cada máquina. Favor de anotar los datos en la placa en caso de que la placa de identificación sea destruida o perdida. En todos los pedidos para repuestos necesita siempre el modelo, el número de referencia, el nivel de revisión y el número de serie de la máquina en cuestión.

Los números de partes en negritas en las Listas Ilustradas de Partes son los repuestos recomendados, esto quiere decir que estas partes se desgastarán bajo circunstancias de funcionamiento normales y pueden requerir servicio periódico o su reemplazo. Se recomienda que el cliente mantenga un abastecimiento adecuado de estas partes para poder satisfacer la demanda requerida por el servicio a la máquina. La cantidad de repuestos que el cliente necesitará para reparaciones dependerá de la póliza de servicio de cada cliente.

Los números de mi máquina son:

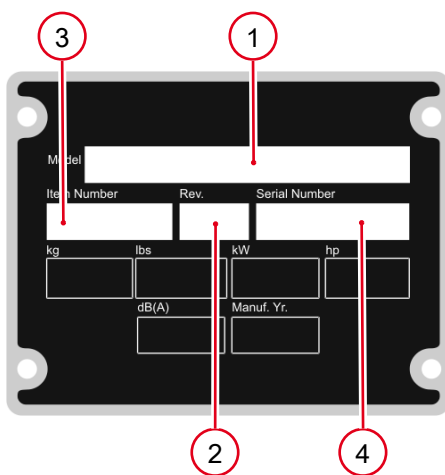

1. Modelo
2. Nivel de revisión
3. Número de referencia
4. Número de Serie

Tabla de conversión

Unidad de volumen	
1 ml	0.034 US fl.oz.
1 l	0.260 gal
Unidad de longitud	
1 mm	0.039 in
1 m	3.280 ft
Peso	
1 kg	2.200 lbs
1 g	0.035 oz
Velocidad	
1 km/h	0.620 mph
Par de apriete	
1 Nm	0.740 ft.lbs

Une plaque signalétique mentionnant le modèle, le numéro de référence, le niveau de revision et le numéro de série est fixée sur chaque machine. Veuillez noter les informations relevées sur cette plaque de façon à ce qu'elles soient toujours disponibles si la plaque signalétique venait à être perdue ou endommagée. Lorsque vous commandez des pièces détachées ou vous sollicitez des informations après-vente, on vous demandera toujours de préciser le modèle, le numéro de référence, le niveau de revision et le numéro de série de la machine.

Les numéros de pièces imprimés en caractères gras dans les Listes des Pièces Détachées de ce manuel sont les pièces détachées recommandées par la Wacker. Cela veut dire que ces pièces sont sujettes à usure dans des conditions de travail normales et peuvent nécessiter de l'entretien ou leur remplacement. Nous recommandons que vous disposiez d'un stock de ces pièces pour pouvoir satisfaire la demande d'entretien de cette machine. Le client doit décider lui-même de la quantité exacte de pièces de rechange qu'il disposera dans ses stocks.

Les numéros de ma machine sont :

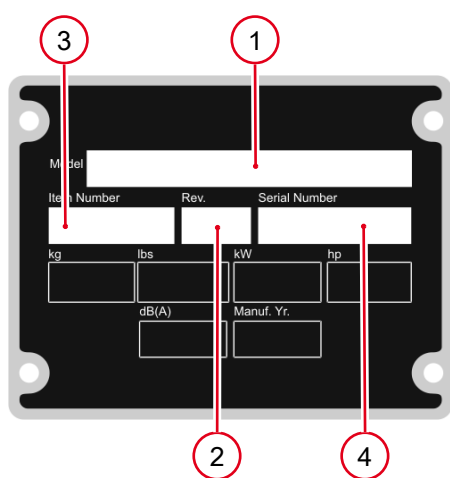

1. Typ
2. Version
3. Artikel-Nr.
4. Maschinen-Nr.

Table de conversion

Unité de volume	
1 ml	0.034 US fl.oz.
1 l	0.260 gal
Unité de longueur	
1 mm	0.039 in
1 m	3.280 ft
Poids	
1 kg	2.200 lbs
1 g	0.035 oz
Vitesse	
1 km/h	0.620 mph
Couple de serrage	
1 Nm	0.740 ft.lbs

Vibrationplatte Kpl. Vibratory Plate Cpl. Plancha Vibradora Cpl. Plaque Vibrante Cpl.	10
---	----

Vibrationplatte Kpl. Vibratory Plate Cpl. Plancha Vibradora Cpl. Plaque Vibrante Cpl.	12
---	----

Deichel Skandinavien Auführung Center Pole Scandinavia Version Barra De Mando Escandinavia Versión Timon Scandinavie Version	14
---	----

Obermae Kpl. Upper Mass Cpl. Masa Superior Cpl. Massa Superieure Cpl.	16
---	----

Batteriechutz Kpl. Battery Protection Cpl. Protección De Batería Cpl. Protection De Batterie Cpl.	20
---	----

Batteriedeckel Kpl. Battery Cover Cpl. Tapa De Batería Cpl. Couvercle De Batterie Cpl.	22
--	----

Untermae Baseplate Masa Inferior Masse Inferieure	24
--	----

Erreger Exciter Excitador Excitatrice	26
--	----

Deichel Kpl. Center Pole Cpl. Barra De Mando Cpl. Timon Cpl.	30
--	----

Deichelkopf Kpl. Center Pole Head Cpl. Cabezal De Mando Cpl. Tête De Timon Cpl.	34
---	----

Kupplung Kpl. Coupling Cpl. Embrague Cpl. Embrayage Cpl.	36
--	----

Fliehkraftkupplung Kpl. Centrifugal Clutch Cpl. Embrague Centrifugo Cpl. Embrayage Centrifuge Cpl.	38
--	----

Aufkleber Labels Calcomanías Autocollants	40
--	----

Zubehör
Accessoires
Accesorios
Accessories

Anbauplatten-Satz Extension Plate Kit Juego De Placa De Extensión Jeu De Elargisseur	42
---	----

Anbauplatten-Satz Extension Plate Kit Juego De Placa De Extensión Jeu De Elargisseur	44
---	----

Anbauplatten-Satz Extension Plate Kit Juego De Placa De Extensión Jeu De Elargisseur	46
---	----

Schraubenatz Set Of Screws Juego De Tornillos Jeu De Vis	48
---	----

Gleitvorrichtung PGV DPU 6555 Urethane Pad Pgv Dpu 6555 Placa De Deslizamientopgv Dpu 6555 Jeu De Tapis En Polyuréthane	50
--	----

Andrehkurbel Rückschlagicher Starting Crank Manivela De Arranque Manivelle De Démarrage	52
--	----

Anbauatz Andrehkurbel Kit-Mounting-Starting Crank Juego-Instalación-Manivela De Arranque Jeu De Montage-Manivelle De	54
---	----

Nachrütatz Riemenberuhiger Kit-Retrofit Belt Guide Juego De Modificaciónguía De Correa Lot De Rattrapage	56
---	----

Nachrütatz Rental DPU6555 Kit-Retrofit Rental Dpu6555 Juego De Modificación Rental Dpu6555 Lot De Rattrapage	58
---	----



Vibratory plate cpl.
Plancha vibradora cpl.
Plaque vibrante cpl.
Vibrationplatte Kpl.

DPU6555HEC

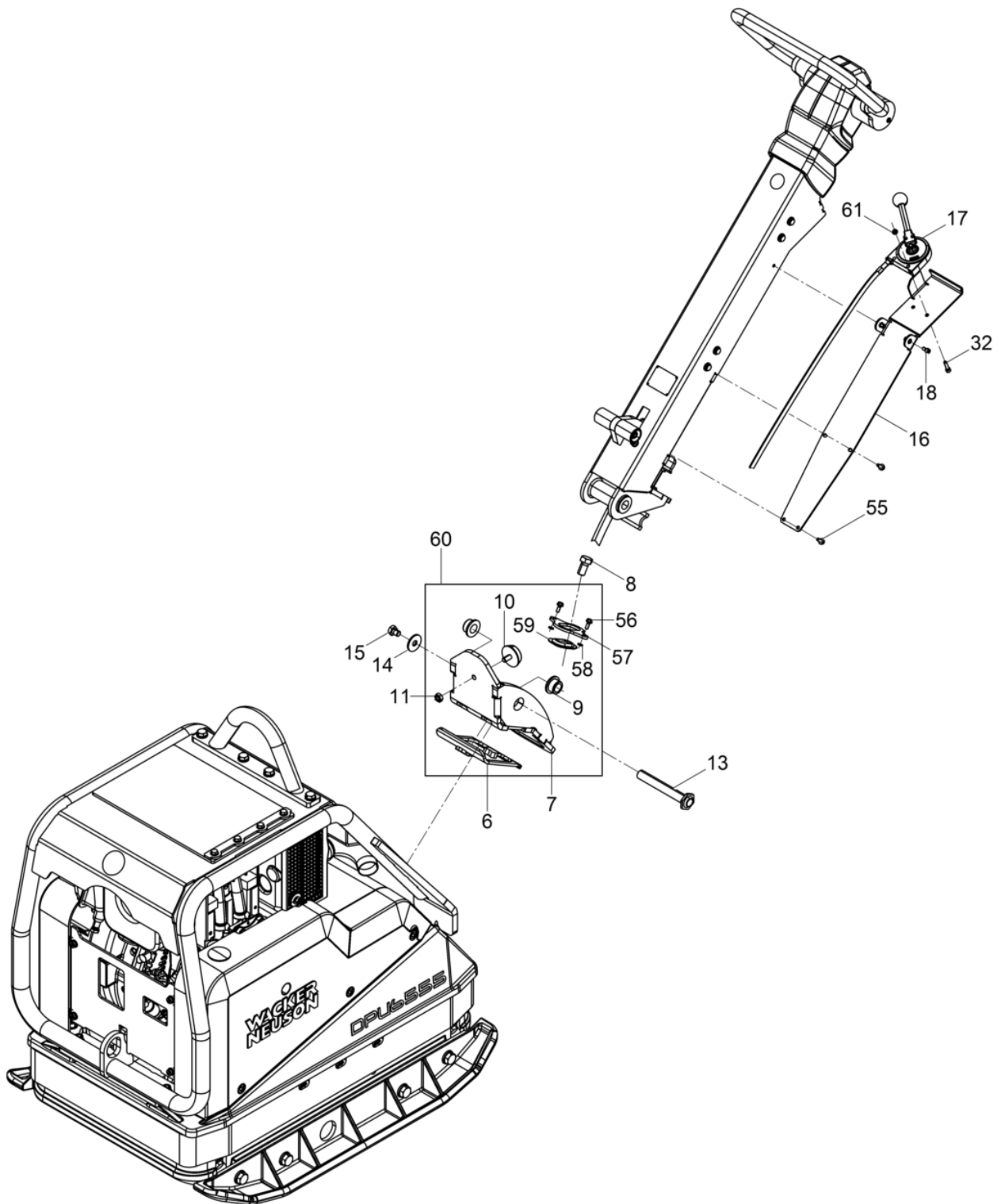

Pos. Ref.	Artikel Nr. Part No.	Qty.	Unit	Beschreibung Description	Description Description	Abm. Measur.	Norm Standard
						Drehm. Torque	Schmierstoff Sealant
6	5100010503	1	PC	Dichtungprofil Junta	Profiled joint Joint d'étanchéité profilé		
7	5100003725	1	PC	Deichelbock Caballete de apoyo	Support Support		
8	5000011523	4	PC	Sechskantchraube Tornillo hexagonal	Hexagonal head cap screw Vis à tête hexagonale	M16 x 30 210Nm/155ft.lbs	DIN933
9	5100004367	2	PC	Buche Buje	Bush Boîte		
10	5100005558	1	PC	Anchlagpuffer Amortiguador	Shockmount Silentbloc	50 x 18 M10 x 20	
11	5000010883	1	PC	Sechskantmutter Tuerca hexagonal	Hexagon nut Écrou hexagonal		
13	5100009632	1	PC	Ache Eje	Axle Axe		
14	5000010376	1	PC	Scheibe Arandela	Flat washer Rondelle	A13	DIN9021
15	5000014316	1	PC	Sechskantchraube Tornillo hexagonal	Hexagonal head cap screw Vis à tête hexagonale	M12 x 16 86Nm/63ft.lbs	DIN933
16	5100009950	1	PC	Deckblech Kpl. Cubierta de chapa cpl.	Cover plate cpl. Coife cpl.		
17	5100036296	1	PC	Betätigung Regulador	Control Commande		
18	5000011553	2	PC	Zylinderchraube Tornillo cilíndrico	Cheese head screw Vis à tête cylindrique	10Nm/7ft.lbs	
32	5000011550	2	PC	Zylinderchraube Tornillo cilíndrico	Cheese head screw Vis à tête cylindrique	M6 x 25 10Nm/7ft.lbs	ISO4762
55	5000204408	4	PC	Schraube Tornillo	Screw Vis	DE M 6x 16	DIN7500
56	5000204408	2	PC	Schraube Tornillo	Screw Vis	DE M 6x 16	DIN7500
57	5100010505	1	PC	Blech Chapa	Plate Tôle		
58	5000010744	2	PC	Scheibe Arandela	Washer Rondelle	6,4	DIN433
59	5100010504	1	PC	Dichtung Junta	Gasket Joint		
60	5100010938	1	PC	Deichelbock Kpl. Caballete de apoyo cpl.	Support cpl. Support cpl.		
61	5000010880	2	PC	Sechskantmutter Tuerca hexagonal	Hexagon nut Écrou hexagonal		

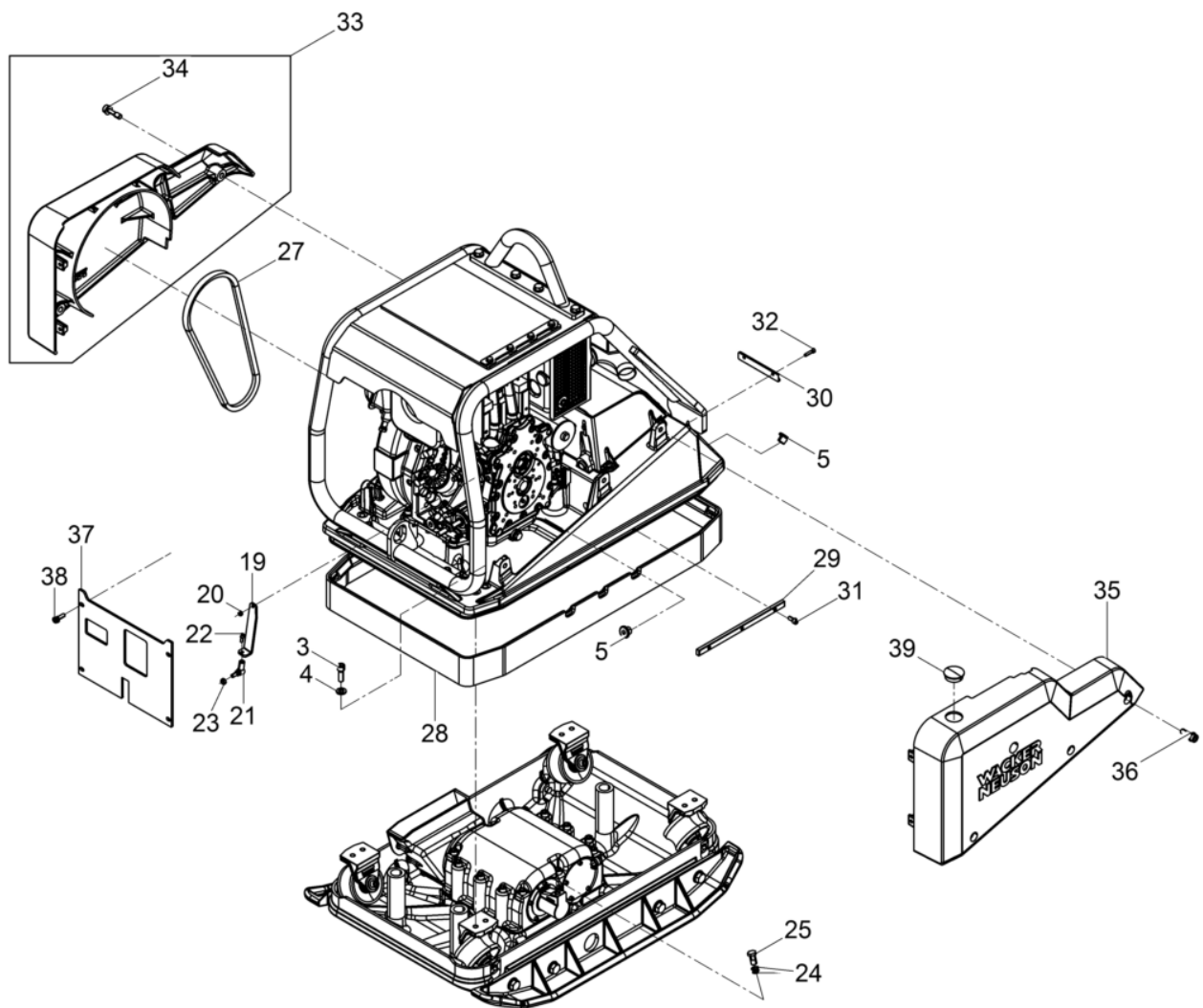

Pos. Ref.	Artikel Nr. Part No.	Qty.	Unit	Beschreibung Description	Description Description	Abm. Measur.	Norm Standard
						Drehm. Torque	Schmierstoff Sealant
3	5000011528	8	PC	Zylinderchraube Tornillo cilíndrico	Cheese head screw Vis à tête cylindrique	M12 x 35 86Nm/63ft.lbs	ISO4762
4	5000021465	8	PC	Sicherungscheibe Arandela de seguridad	Lock washer Rondelle d'arrêt	HS12	
5	5000103880	2	PC	Rohrdurchführung Tubo de guía	Pipe guide Passage de tuyau		
19	5000103971	1	PC	Hebel Palanca	Lever Levier		
20	5000021679	1	PC	Sechskantmutter Tuerca hexagonal	Hexagon nut Écrou hexagonal	M6	DIN980
21	5000038403	1	PC	Winkelgelenk Articulación angular	Angular joint Jointure engulaire	AS13	DIN71802
22	5000011553	1	PC	Zylinderchraube Tornillo cilíndrico	Cheese head screw Vis à tête cylindrique	10Nm/7ft.lbs	
23	5000010882	1	PC	Sechskantmutter Tuerca hexagonal	Hexagon nut Écrou hexagonal		
24	5000012624	2	PC	Dichtring Anillo de junta	Gasket Bague d'étanchéité	A14 x 18	DIN7603
25	5000043201	1	PC	Hohlchraube Perno hueco	Banjo bolt Boulon creux à filet femelle	10-3	DIN7643
27	5000094072	1	PC	Keilriemen Correa en v	V-belt Courroie	17 x 1080	
28	5100009633	1	PC	Schürze Protección	Apron Tablier		
29	5000097110	2	PC	Leite Listón	Bar Listeau		
30	5100009635	1	PC	Leite Listón	Bar Listeau		
31	5000103962	6	PC	Zylinderchraube Tornillo cilíndrico	Cheese head screw Vis à tête cylindrique	M8 x 18 25Nm/18ft.lbs	ISO4762
32	5000011550	2	PC	Zylinderchraube Tornillo cilíndrico	Cheese head screw Vis à tête cylindrique	M6 x 25 10Nm/7ft.lbs	ISO4762
33	5100002778	1	PC	Riemenchutz Protección de la polea	Belt guard Protection de courroie		
34	5000220202	3	PC	Dünnchaftchraube Tornillo	Screw Vis	M12x 40	
35	5000220365	1	PC	Schutzhaube Cubierta de protección	Protective hood Capot de protection		
36	5000220325	3	PC	Sicherungschraube Tornillo	Screw Vis	M 12x 35	
37	5000220190	1	PC	Schutzblech Chapa protectora	Guard plate Tôle de protection		
38	5000129420	4	PC	Zylindericherungschraube Tornillo de seguridad	Socket head cap screw Poignée supplémentaire		
39	5000126654	1	PC	Verchlußstopfen Tapón de cierre	Locking plug Bouchon de fermeture	M26 x 1,5	

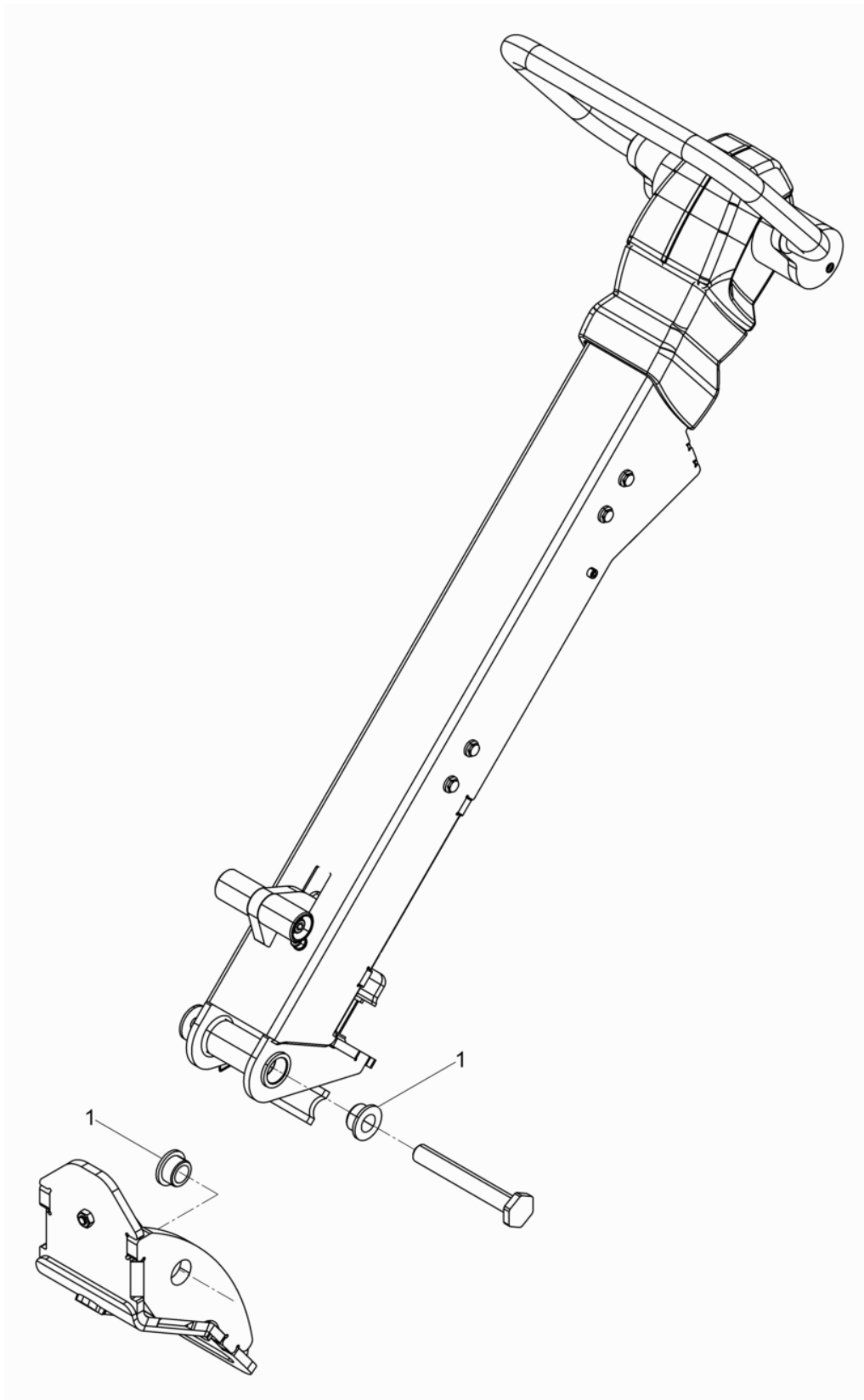

DPU6555HEC**DeichEl Skandinavien AuFührung
Center pole scandinavia version
Barra de mando escandinavia versión
Timon scandinavie version**

Pos. Ref.	Artikel Nr. Part No.	Qty.	Unit	Beschreibung Descripción	Description Description	Abm. Measur.	Norm Standard
						Drehm. Torque	Schmierstoff Sealant
1	5100042458	4	PC	Meingbuche Buje de latón	Brass bush Boîte en laiton		



Upper mass cpl.
Masa superior cpl.
Masa superieure cpl.
Obermae Kpl.

DPU6555HEC

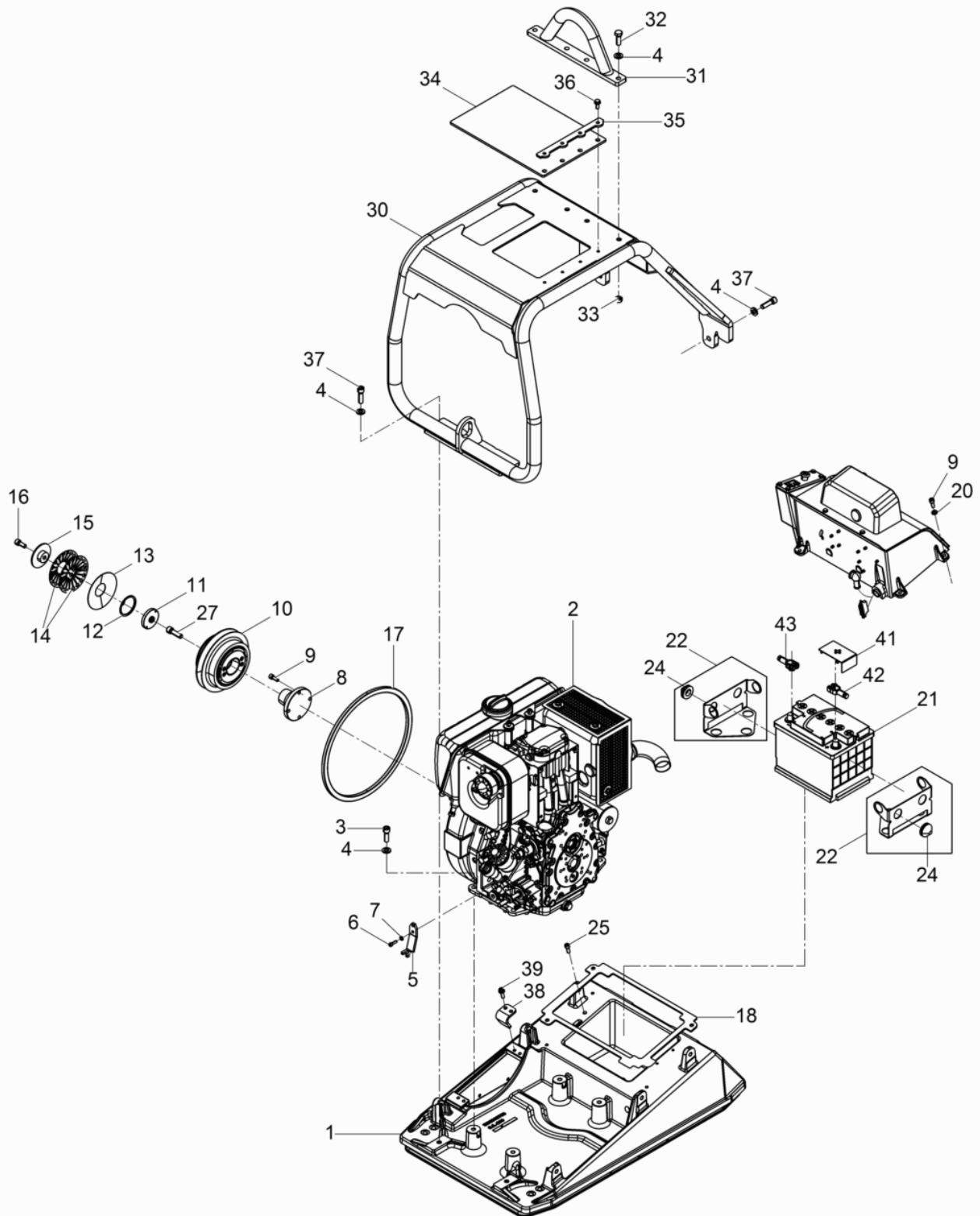

Pos. Ref.	Artikel Nr. Part No.	Qty.	Unit	Beschreibung Description	Description Description	Abm. Measur.	Norm Standard
						Drehm. Torque	Schmierstoff Sealant
1	5100003737	1	PC	Obermae Masa superior	Upper mass Masse superieure		
2	5100043177	1	PC	Dieelmotor Motor diesel	Diesel engine Moteur diesel		
3	5000011528	4	PC	Zylinderchraube Tornillo cilíndrico	Cheese head screw Vis à tête cylindrique	M12 x 35 86Nm/63ft.lbs	ISO4762
4	5000021465	12	PC	Sicherungcheibe Arandela de seguridad	Lock washer Rondelle d'arrêt	HS12	
5	5000103893	1	PC	Winkel Ángulo	Angle Coude		
6	5000011551	2	PC	Zylinderchraube Tornillo cilíndrico	Cheese head screw Vis à tête cylindrique	10Nm/7ft.lbs	
7	5000010624	2	PC	Scheibe Arandela	Flat washer Rondelle		
8	5000069900	1	PC	Flanch Brida	Flange Bride		
9	5000012629	8	PC	Zylinderchraube Tornillo cilíndrico	Cheese head screw Vis à tête cylindrique	25Nm/18ft.lbs	
10	5000102208	1	PC	Kupplung Kpl. Embrague cpl.	Coupling cpl. Embrayage cpl.		
11	5000058546	1	PC	Scheibe Disco	Disc Disque		
12	5000021147	1	PC	Sicherungring Anillo de retención	Retaining ring Bague d'arrêt	60 x 2	DIN472
13	5000048273	1	PC	Dichtung Junta	Seal Joint		
14	5000048374	2	PC	Tellerfeder Resorte de platillo	Cup spring Ressort belleville		
15	5000058547	1	PC	Pilz Fungiforme	Button Butée		
16	5000011534	1	PC	Zylinderchraube Tornillo cilíndrico	Cheese head screw Vis à tête cylindrique	M10 x 30 49Nm/36ft.lbs	ISO4762
17	5000048539	1	PC	Dichtung Junta	Seal Joint		
18	5000220183	1	PC	Dichtung Junta de estanqueidad	Gasket Garniture		
20	5000010742	4	PC	Scheibe Arandela	Washer Rondelle		
21	5100021329	1	PC	Batterie Batería	Battery Batterie		
22	5100011287	2	PC	Batterieprotector Kpl. Protección de batería cpl.	Battery protection cpl. Protection de batterie cpl.		
24	5000124255	19	PC	Batteriepuffer Tope	Shockmount Tampon		
25	5000013574	1	PC	Zylinderchraube Tornillo cilíndrico	Cheese head screw Vis à tête cylindrique	25Nm/18ft.lbs	
27	5100010091	1	PC	Zylinderchraube Tornillo cilíndrico	Cheese head screw Vis à tête cylindrique	M12x 40 86Nm/63ft.lbs	
30	5000220379	1	PC	Schutzrahmen Armazón de protección	Protective frame Cadre protection		
31	5000099055	1	PC	ÖE Punto de izaje	Hook Crochet		
32	5000011422	4	PC	Sechskantchraube Tornillo hexagonal	Hexagonal head cap screw Vis à tête hexagonale	M12 x 35 86Nm/63ft.lbs	DIN933
33	5000010366	4	PC	Sechskantmutter Tuerca hexagonal	Hexagon nut Écrou hexagonal	M12X1.75	DIN985

Upper mass cpl.
Masa superior cpl.
Masa superieure cpl.
Obermae Kpl.

DPU6555HEC

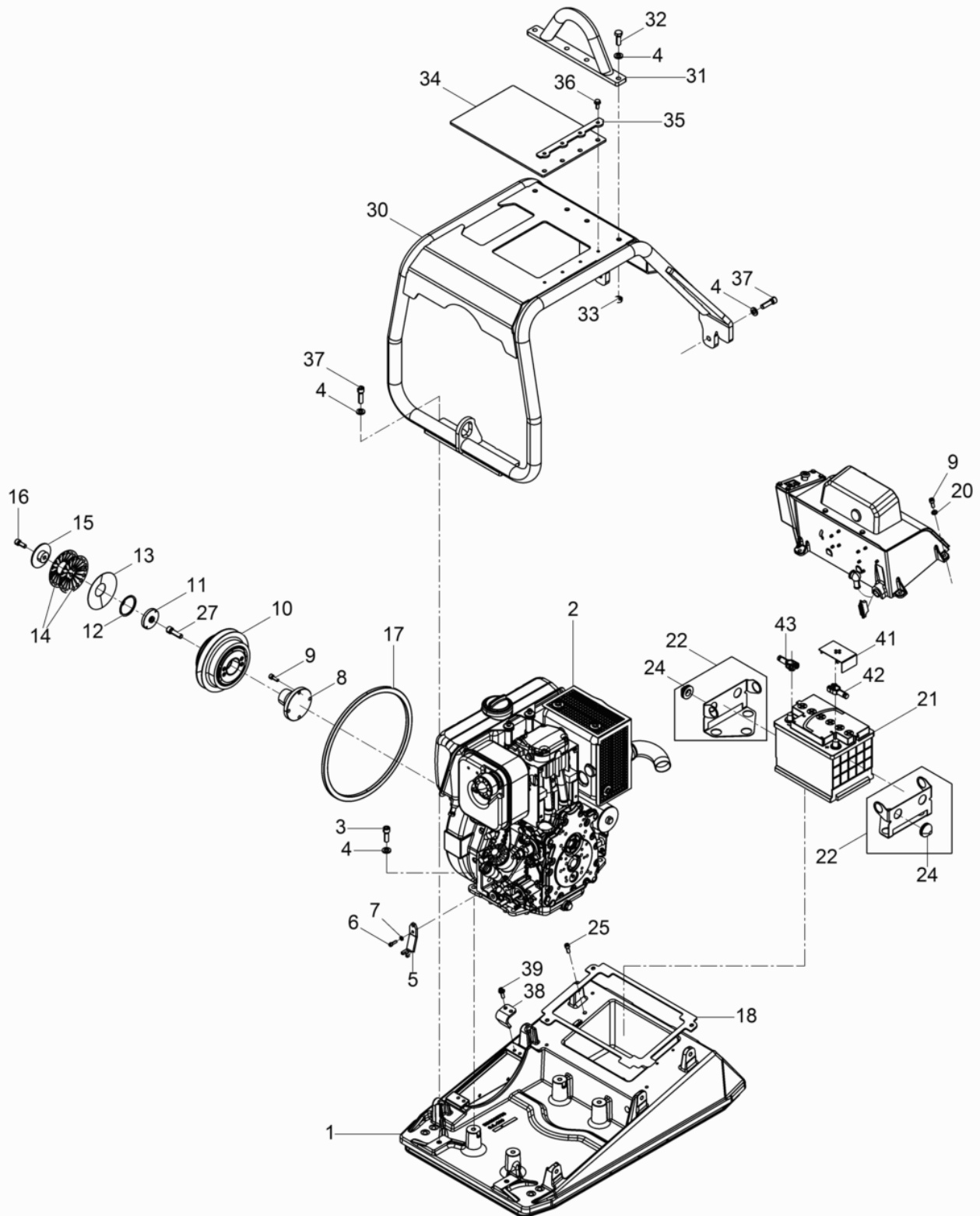

Pos. Ref.	Artikel Nr. Part No.	Qty.	Unit	Beschreibung Descripcion	Description Description	Abm. Measuram.	Norm Standard
						Drehm. Torque	Schmierstoff Sealant
34	5000099535	1	PC	Platte Placa	Plate Plaque		
35	5000099047	1	PC	Leite Listón	Bar Listeau		
36	5000105944	4	PC	Schraube Tornillo	Screw Vis	DE M8 x 20	DIN7500
37	5000201094	4	PC	Zylinderchraube Tornillo cilíndrico	Cheese head screw Vis à tête cylindrique	M12 x 50 120Nm/89ft.lbs	ISO4762
38	5000220334	2	PC	Winkel Angulo	Angle Angle		
39	5000129420	4	PC	Zylindericherungschraube Tornillo de seguridad	Socket head cap screw Poignée supplémentaire		
41	5100011307	1	PC	Plupol-Abdeckung Cubierta	Positive pol cover Couverture		
42	5100015202	1	PC	Polklemme Plupol Terminal de polo positivo	Pole terminal positive Borne polaire positive		
43	5100015203	1	PC	Polklemme Minupol Terminal de polo negativo	Pole terminal negative Borne polaire negative		

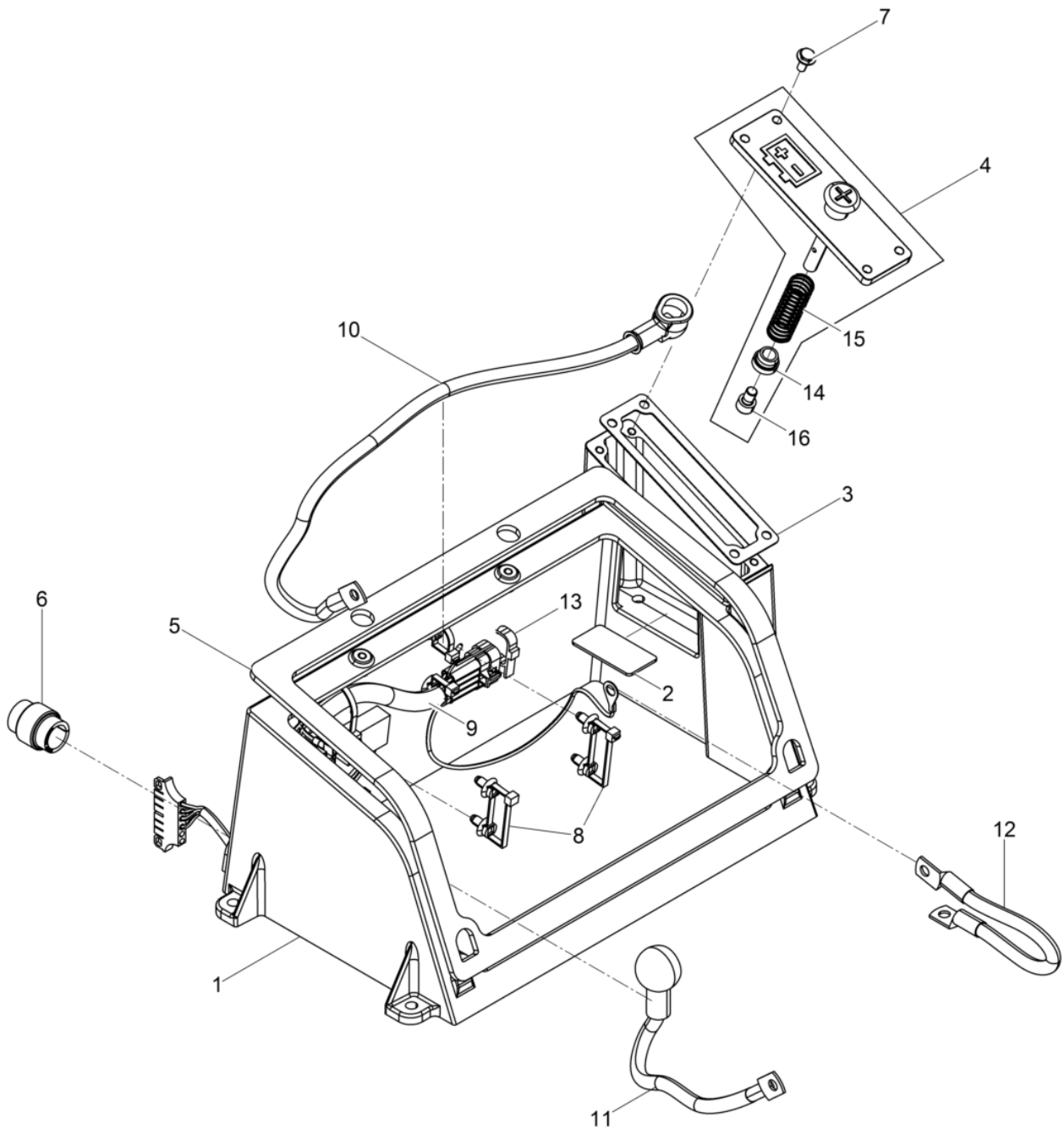

Pos. Ref.	Artikel Nr. Part No.	Qty.	Unit	Beschreibung Descripción	Description Description	Abm. Measur.	Norm Standard
						Drehm. Torque	Schmierstoff Sealant
1	5100011288	1	PC	Batteriechutz Protección de batería	Battery protection Protection de batterie		
2	5100010149	1	PC	Pad Cojín	Pad Coussin		
3	5000216678	1	PC	Dichtung Junta de estanqueidad	Gasket Garniture		
4	5100011304	1	PC	Starthilfe Kpl. Embolo buzo cpl.	Starting device cpl. Fouloir plongeur cpl.		
5	5000220173	1	PC	Dichtung Junta de estanqueidad	Gasket Garniture		
6	5000220432	1	PC	Einatz Inserto	Insert Insertion		
7	5000210194	4	PC	Sicherungschraube Tornillo	Corrugated-head screw Vis		
8	5100011341	9	PC	Kabelbinder Fijación	Tie cable Attache		
9	5100009683	1	PC	Kabelbaum Mazo de cables	Cable harness Harnais de câbles		
10	5100010865	1	PC	Fremdtarterkabel Cable	Battery boost cable Câble		
11	5100025321	1	PC	Plu-Pol-Leitung Cable polo positivo	Positive pole strap Ligne borne positive		
12	5100010866	1	PC	Minu-Pol-Leitung Cable polo negativo	Negative pole strap Ligne borne négative		
13	5000047388	1	PC	Kabelbinder Fijación de cables	Cable yarn Attache de câble		
14	5100009601	1	PC	Buche Buje	Bush Boîte		
15	5100011308	1	PC	Druckfeder Resorte de compresión	Compression spring Ressort de pression	1x17,5x100x8,5	
16	5000013574	1	PC	Zylinderchraube Tornillo cilíndrico	Cheese head screw Vis à tête cylindrique	25Nm/18ft.lbs	

Battery cover cpl.
Tapa de batería cpl.
Couvercle de batterie cpl.
Batteriedeckel Kpl.

DPU6555HEC

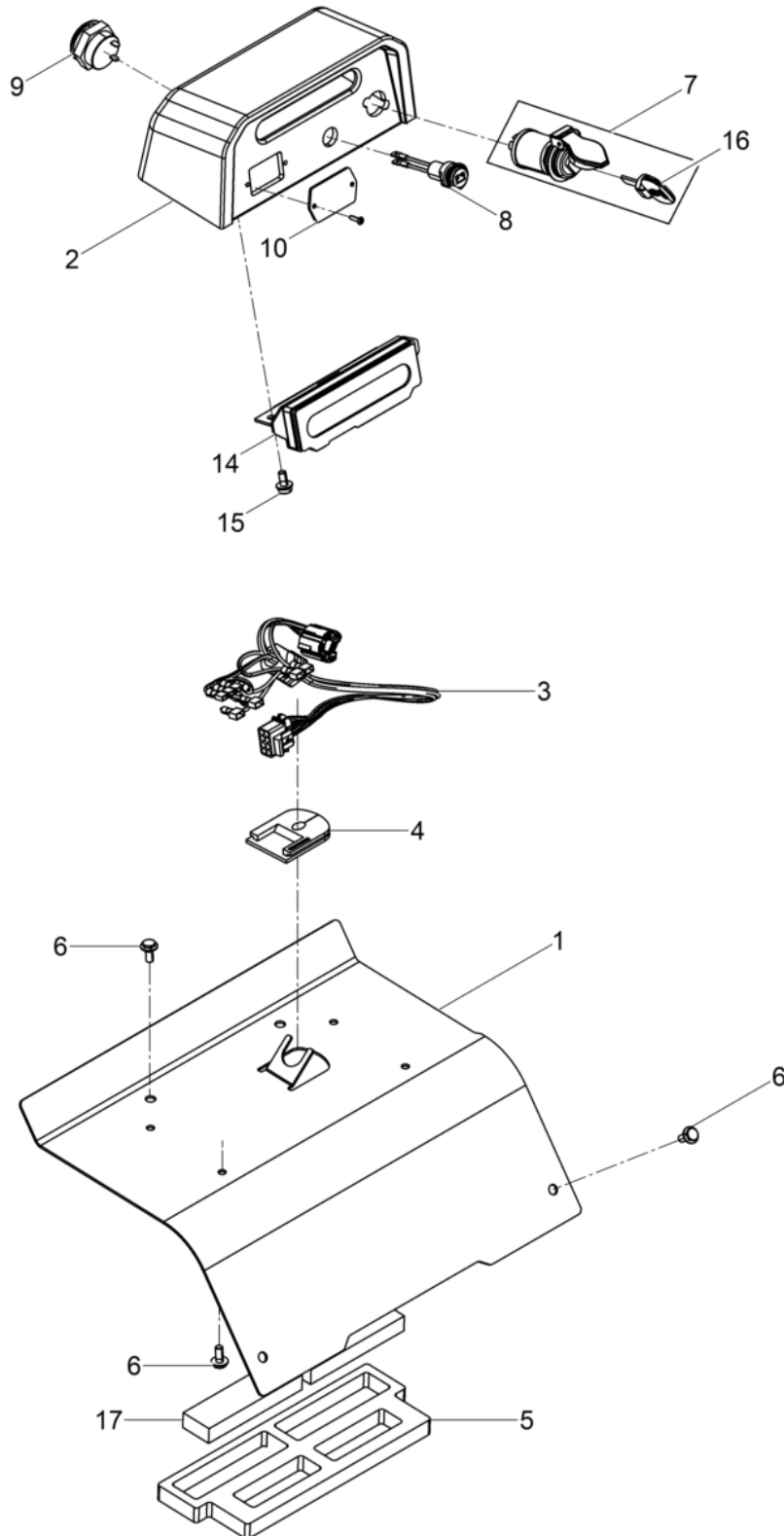

Pos. Ref.	Artikel Nr. Part No.	Qty.	Unit	Beschreibung Descripción	Description Description	Abm. Measur.	Norm Standard
						Drehm. Torque	Schmierstoff Sealant
1	5100020821	1	PC	Batteriedeckel Protección de batería	Battery cover Couvercle de batterie		
2	5100005886	1	PC	Gehäuse Carcasa	Housing Carter		
3	5100009620	1	PC	Spiralkabel Cable espiral	Helix cable Câble spirale		
4	5100009911	1	PC	Dichtung Junta	Gasket Joint		
5	5100020556	1	PC	Kien Für Batterie Almohadilla	Insulating cushion Coussin		
6	5000210194	8	PC	Sicherungschraube Tornillo	Corrugated-head screw Vis		
7	5100011296	1	PC	Zündanlchalter Interruptor de arranque	Ignition starter switch Interrupteur démarreur		
8	5000129797	1	PC	LED Leuchte Diodo	Led Diode luminescente		
9	5000220234	1	PC	Signalgeber Señal acústica	Acoustic signal Signal acoustique		
10	5100016734	1	PC	Abdeckung Cubierta	Covering Couverture		
14	5100009673	1	PC	Anzeigeinheit Kpl. Consola de visualización cpl.	Display cpl. Console de visualisation cpl.		
15	5100010512	2	PC	Sicherungschraube Tornillo	Corrugated-head screw Vis		
16	5000220118	1	PC	Schlüssel Llave	Key Clé		
17	5100020618	2	PC	Filtermatte Esteras filtrante	Filter mat Élément filtrant		

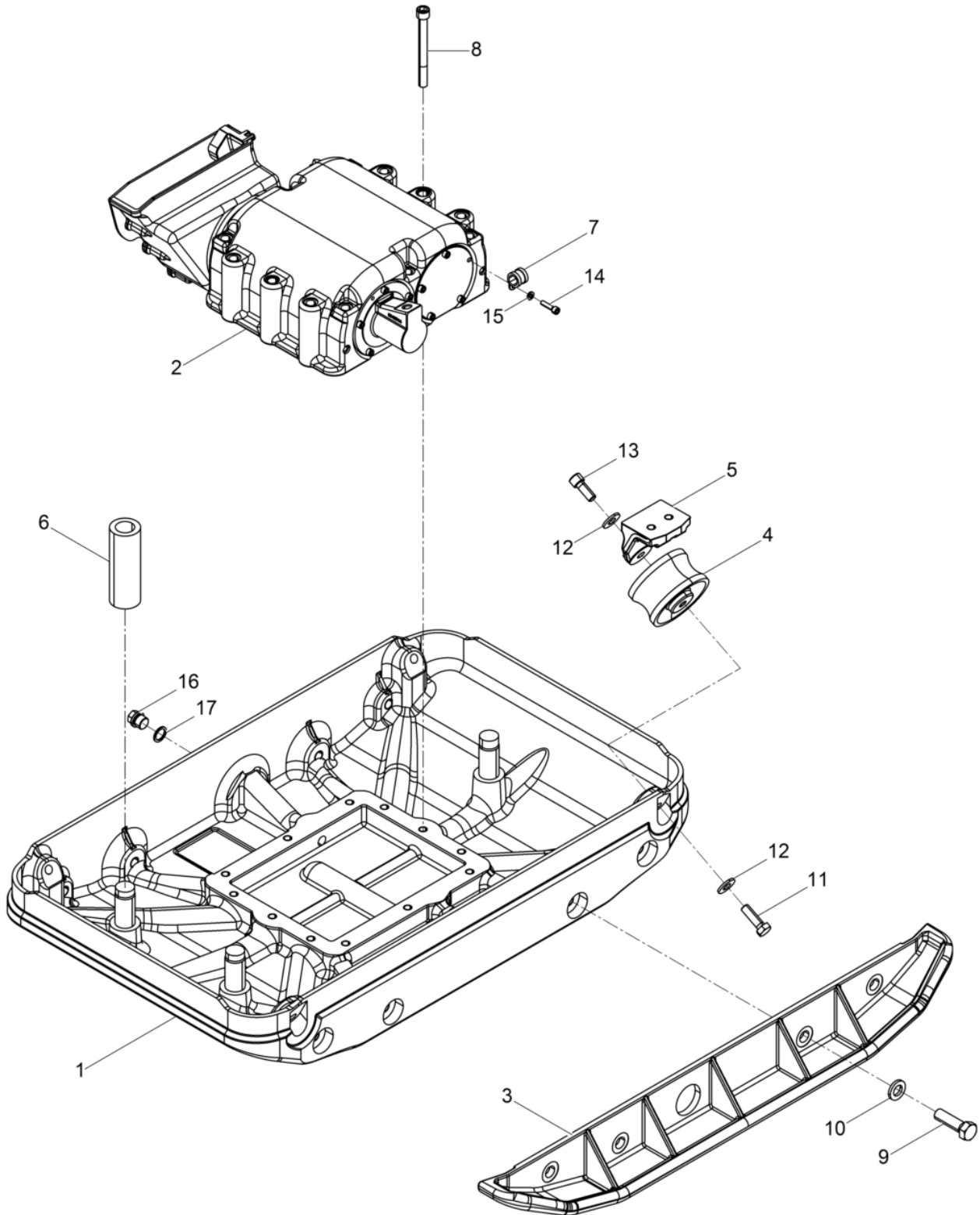

Pos. Ref.	Artikel Nr. Part No.	Qty.	Unit	Beschreibung Description	Description Description	Abm. Measur.	Norm Standard
						Drehm. Torque	Schmierstoff Sealant
1	5000102083	1	PC	UntermaE Masa inferior	Baseplate Masse inferieure		
2	5000220084	1	PC	Erreger Kpl. Excitador cpl.	Exciter cpl. Excitateur cpl.		
3	5000044442	2	PC	Anbauplatte Placa de extensión	Extension plate Elargisseur	8 cm	
4	5002004814	4	PC	Gimmetall-Kerblager Mit Bund Amortiguador	Shockmount Silentbloc	100 x 58	
5	5000102105	4	PC	Pufferbock Soporte tope	Support Support d'amortisseur		
6	5000034442	3	PC	Dämpfungsbuche Buje	Bushing Douille		
7	5000017123	1	PC	Rohrchelle Abrazadera	Pipe clamp Collier pour tuyau		
8	5000094518	12	PC	Zylinderchraube Tornillo cilíndrico	Cheese head screw Vis à tête cylindrique	M12 x 120 120Nm/89ft.lbs	ISO4762
9	5000039191	8	PC	Sechskantchraube Tornillo hexagonal	Hexagonal head cap screw Vis à tête hexagonale	M16 x 1,5 x 55 210Nm/155ft.lbs	DIN961
10	5000021988	8	PC	Sicherungsheibe Arandela de seguridad	Lock washer Rondelle d'arrêt	HS16	
11	5000011421	4	PC	Sechskantchraube Tornillo hexagonal	Hexagonal head cap screw Vis à tête hexagonale	M12 x 40 86Nm/63ft.lbs	DIN933
12	5000031565	8	PC	Spannheibe Arandela elástica	Lockwasher Rondelle de ressort	12	DIN6796
13	5000011529	4	PC	Zylinderchraube Tornillo cilíndrico	Cheese head screw Vis à tête cylindrique	M12 x 30 86Nm/63ft.lbs	ISO4762
14	5000011550	1	PC	Zylinderchraube Tornillo cilíndrico	Cheese head screw Vis à tête cylindrique	M6 x 25 10Nm/7ft.lbs	ISO4762
15	5000010624	1	PC	Scheibe Arandela	Flat washer Rondelle		
16	5000068222	1	PC	Verchlußschraube Tapón roscado	Plug (threaded) Bouchon		
17	5000019156	1	PC	Dichtring Anillo de junta	Gasket Bague d'étanchéité		
19	5000219702	1	PC	Flanch Brida	Flange Bride		

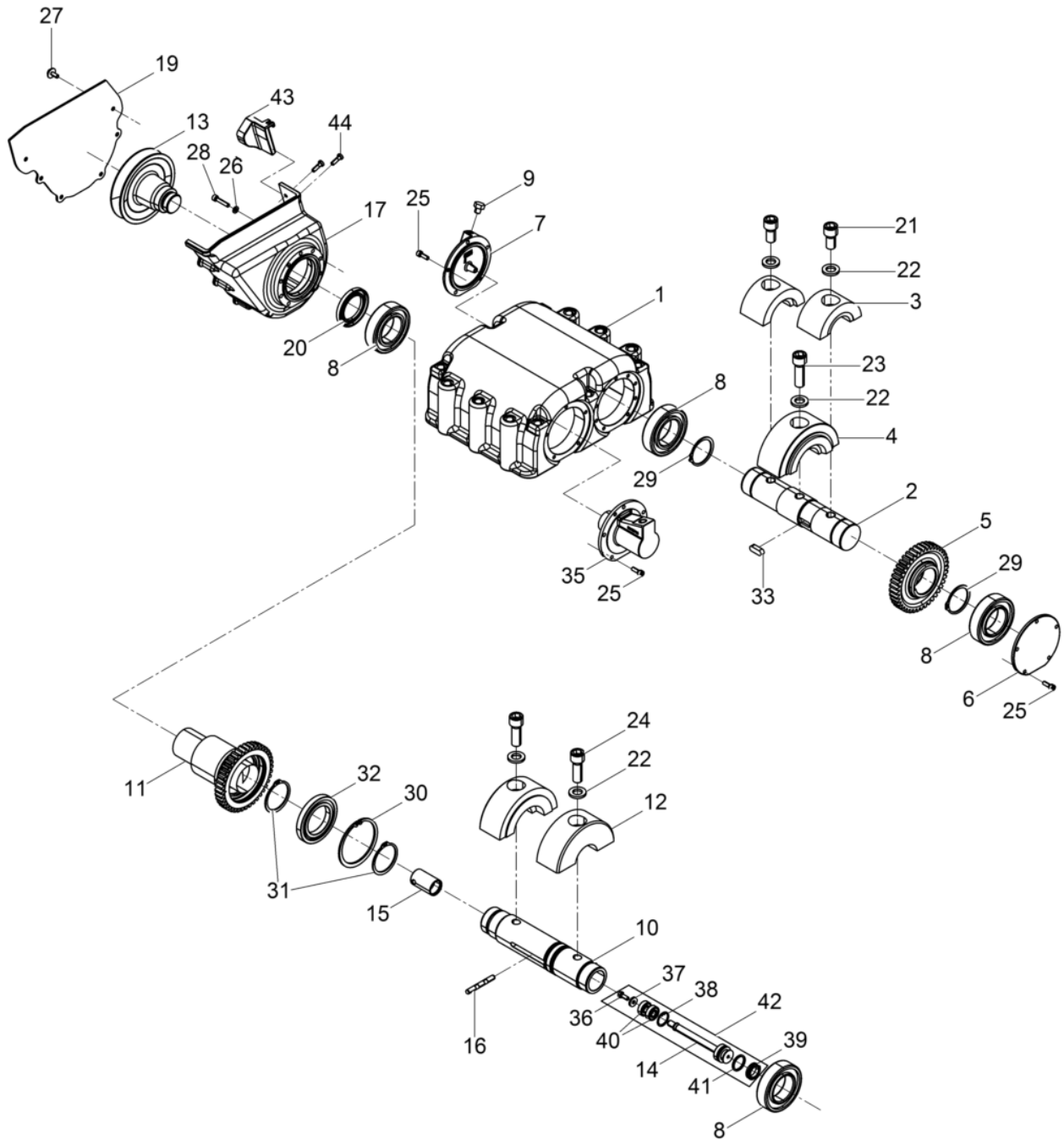

Pos. Ref.	Artikel Nr. Part No.	Qty.	Unit	Beschreibung Description	Description Description	Abm. Measur.	Norm Standard
						Drehm. Torque	Schmierstoff Sealant
1	5000099059	1	PC	Erregergehäuse Carcasa del excitador	Exciter housing Carter excitateur		
2	5000220059	1	PC	Welle Árbol	Shaft Arbre		
3	5000220082	2	PC	Unwucht Masa excéntrica	Eccentric weight Balourd		
4	5000220110	1	PC	Unwucht Masa excéntrica	Eccentric weight Balourd		
5	5000039116	1	PC	Zahnrad Engranaje	Gear wheel Roue dentée		
6	5000039110	1	PC	Deckel Tapa	Cover Couvercle		
7	5000102144	1	PC	Belüftungdeckel Tapa de ventilación	Vent cover Couvercle d'aeration		
8	5000103469	4	PC	Zylinderrollenlager Rodamiento cilíndricos	Cylindrical roller bearing Roulement à rouleaux		
9	5001103030	1	PC	Entlüftungschraube Tornillo de purga	Vent screw Vis d'évacuation d'air		
10	5000220077	1	PC	Welle Árbol	Shaft Arbre		
11	5000220053	1	PC	Vertelhüle Husillo de regulación	Adjusting sleeve Douille de réglage		
12	5000220083	2	PC	Unwucht Masa excéntrica	Eccentric weight Balourd		
13	5000129859	1	PC	Keilriemencheibe Polea en v	V-belt pulley Poulie à courroie		
14	5000220079	1	PC	Bolzen Perno	Bolt Boulon		
15	5000220106	1	PC	Schaltbolzen Perno fijador	Indexing bolt Boulon		
16	5000043382	1	PC	Schalttift Espiga de mando	Tripping pin Broche de manoeuvre		
17	5000201522	1	PC	Schutzkatzen Caja de protección	Protective box Boitier de protection		
19	5000104124	1	PC	Blech Chapa	Plate Tôle		
20	5000048854	1	PC	Wellendichtring Anillo de retén radial	Rotary shaft seal Bague d'étanchéité	48 x 72 x 7,4	
21	5000044634	2	PC	Zylinderchraube Tornillo cilíndrico	Cheese head screw Vis à tête cylindrique	M16 x 30 295Nm/218ft.lbs	ISO4762
22	5000021988	5	PC	Sicherungscheibe Arandela de seguridad	Lock washer Rondelle d'arrêt	HS16	
23	5000043812	1	PC	Zylinderchraube Tornillo cilíndrico	Cheese head screw Vis à tête cylindrique	M16 x 50 295Nm/218ft.lbs	ISO4762
24	5000126300	2	PC	Zylinderchraube Tornillo cilíndrico	Cheese head screw Vis à tête cylindrique	M16 x 45 295Nm/218ft.lbs	ISO4762
25	5000011552	14	PC	Zylinderchraube Tornillo cilíndrico	Cheese head screw Vis à tête cylindrique	M6 x 18 10Nm/7ft.lbs	ISO4762
26	5000010624	9	PC	Scheibe Arandela	Flat washer Rondelle		
27	5100009501	6	PC	Kombi-Schraube Tornillo	Screw Vis	M6 x 16 10Nm/7ft.lbs	
28	5000011549	9	PC	Zylinderchraube Tornillo cilíndrico	Cheese head screw Vis à tête cylindrique	M6 x 30 10Nm/7ft.lbs	ISO4762
29	5002006113	2	PC	Sicherungsring Anillo de retención	Retaining ring Bague d'arrêt		

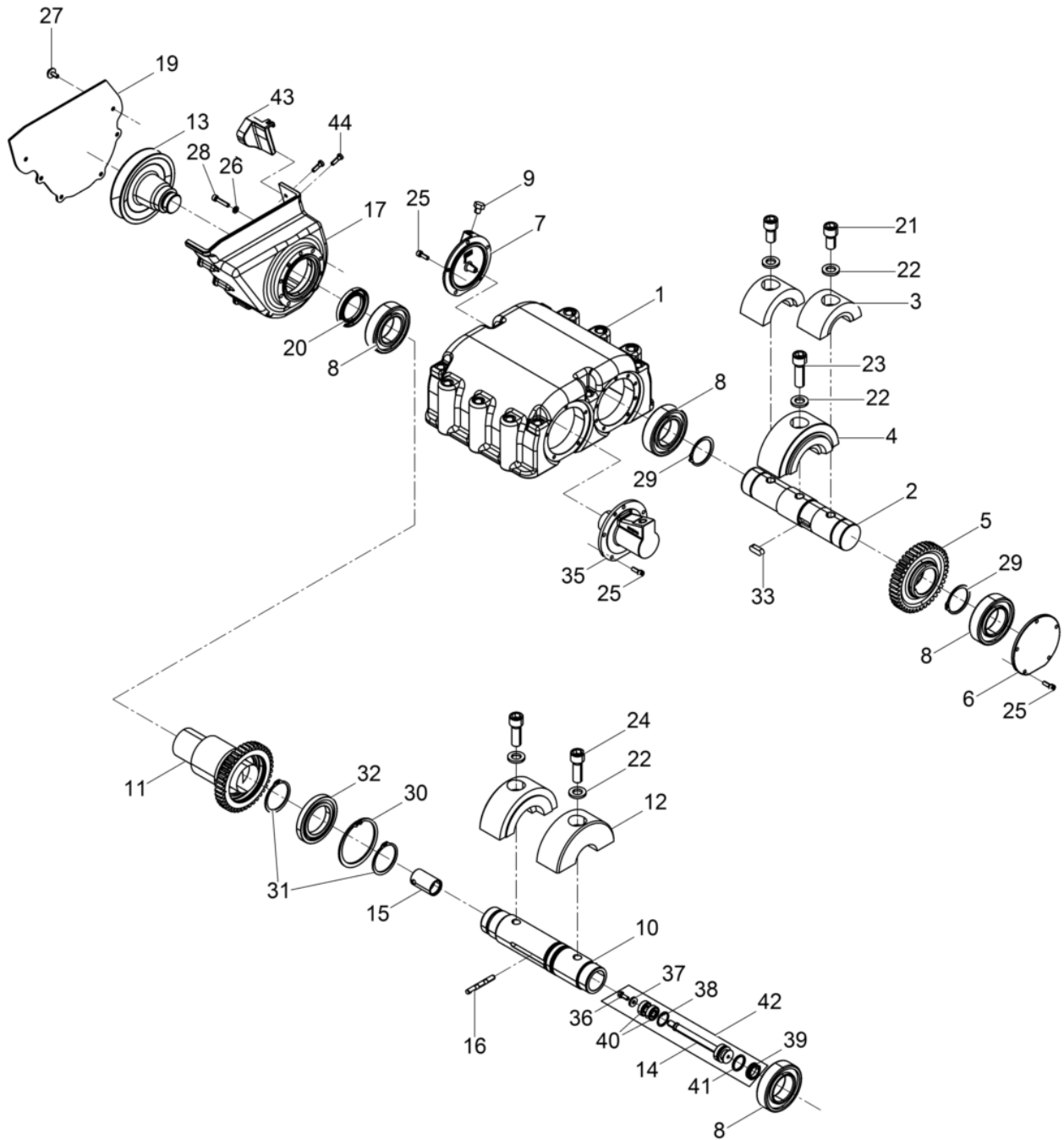

Pos. Ref.	Artikel Nr. Part No.	Qty.	Unit	Beschreibung Descripción	Description Description	Abm. Measur.	Norm Standard
						Drehm. Torque	Schmierstoff Sealant
30	5002007057	1	PC	Sicherungring Anillo de retención	Retaining ring Bague d'arrêt	90 x 3	DIN472
31	5002004822	2	PC	Sicherungring Anillo de retención	Retaining ring Bague d'arrêt	55 x 2	DIN471
32	5000220133	1	PC	Rillenkugellager Rodamiento a bolas	Grooved ball bearing Roulement rainuré à billes		DIN625
33	5002001399	1	PC	Pafeder Chaveta	Fitting key Clavette	A10 x 8 x 28	DIN6885
35	5000048604	1	PC	Zylinderdeckel Tapa del cilindro	Cylinder cover Couvercle de cylindre		
36	5000124717	1	PC	Scheibe Arandela	Washer Rondelle		
37	5000014663	1	PC	Sechskantchraube Tornillo hexagonal	Hexagonal head cap screw Vis à tête hexagonale	M6 x 16 10Nm/7ft.lbs	DIN933
38	5000220384	1	PC	Sicherungring Anillo de retención	Retaining ring Bague d'arrêt	26x 1,20	DIN472
39	5000043203	1	PC	Gummilippenring Reten labial de goma	Lip seal ring Bague en caoutchouc	30 x 20 x 6	
40	5000220383	2	PC	Rillenkugellager Rodamiento a bolas	Grooved ball bearing Roulement rainuré à billes		DIN625
41	5002006991	1	PC	O-Ring Anillo-o	O-ring Bague-o	24 x 3	
42	5000220081	1	PC	Bolzen Kpl. Perno cpl.	Bolt cpl. Boulon cpl.		
43	5100003656	1	PC	Riemenberuhiger Guía de correa	Belt guide Guide-courroie		
44	5100013871	2	PC	Linenkopfchraube Tornillo gota de sebo	Oval head screw Vis noyée lentiforme	6 x 20	

Center pole cpl.
Barra de mando cpl.
Timon cpl.
Deichel Kpl.

DPU6555HEC

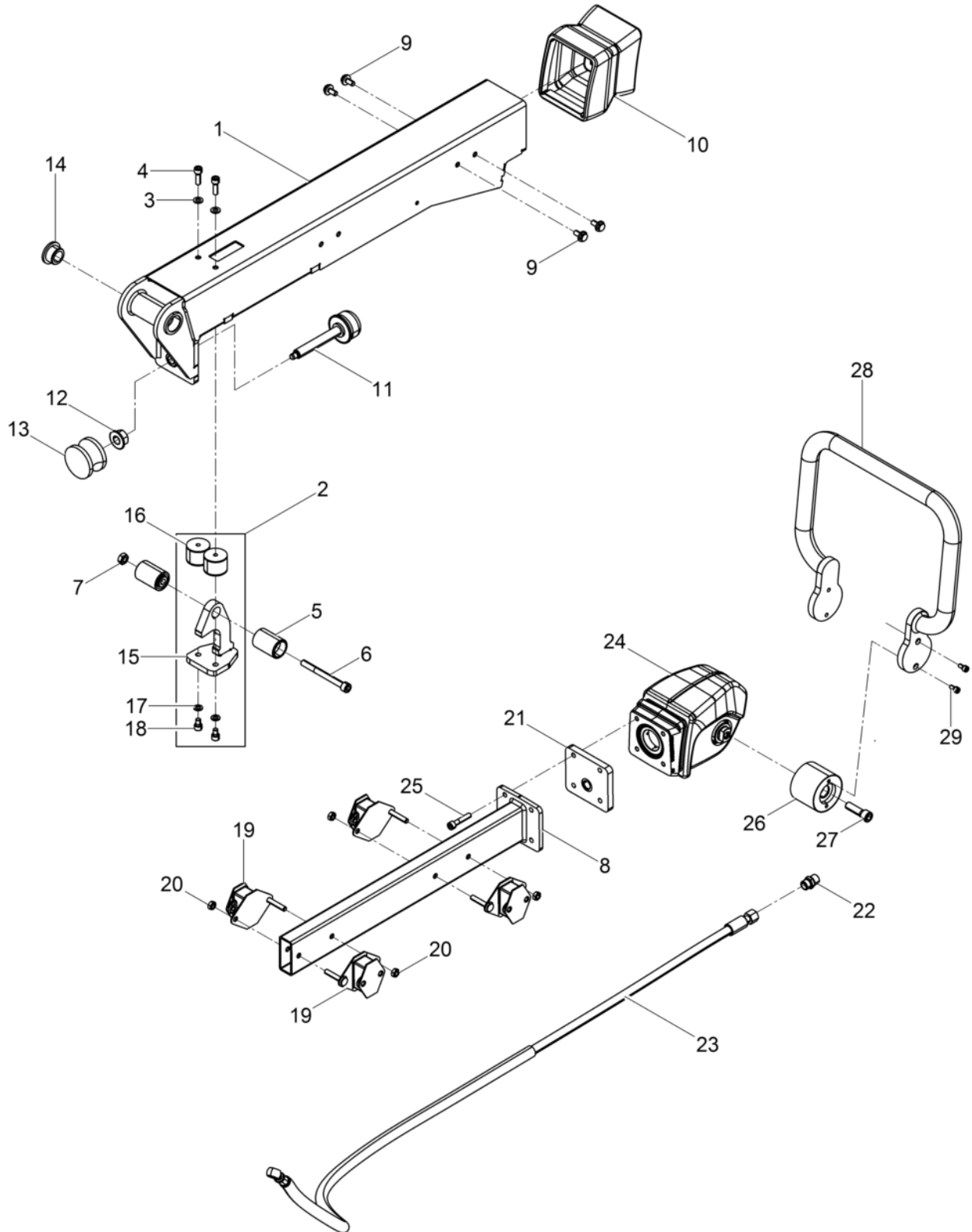

Pos. Ref.	Artikel Nr. Part No.	Qty.	Unit	Beschreibung Descripción	Description Description	Abm. Measur.	Norm Standard
						Drehm. Torque	Schmierstoff Sealant
1	5100009952	1	PC	Deichelrohr Barra de mando tubo	Center pole tube Timon tube		
2	5100005543	1	PC	Arretierung Dispositivo de retención	Lock Dispositif d'arrêt		
3	5000010622	2	PC	Scheibe Arandela	Flat washer Rondelle		
4	5000013574	2	PC	Zylinderchraube Tornillo cilíndrico	Cheese head screw Vis à tête cylindrique		
5	5100002007	2	PC	Arretierungsgriff Empuñadura de retención	Retaining handle Poignée d'arrêt		
6	5000037090	1	PC	Zylinderchraube Tornillo cilíndrico	Cheese head screw Vis à tête cylindrique	M10 x 100 49Nm/36ft.lbs	ISO4762
7	5000010883	1	PC	Sechskantmutter Tuerca hexagonal	Hexagon nut Écrou hexagonal		
8	5100005106	1	PC	Vierkantrohr Kpl. Tubo cuadrado cpl.	Square tube cpl. Tube carré cpl.		
9	5000211795	8	PC	Sicherungschraube Tornillo	Corrugated-head screw Vis		
10	5100005538	1	PC	Faltenbalg Fuelle acordeón	Bellows Soufflet		
11	5000043928	1	PC	Gewindestift Kpl. Husillo roscado cpl.	Threaded spindle cpl. Tige fileté cpl.		
12	5000202866	1	PC	Sechskantmutter Contratuerca	Locknut Contre-écrou	M16	EN1661
13	5000043233	1	PC	Gummi-Metall-Kerbpuffer Tope caucho-metal	Shockmount Tampon métallique oscillant	60 x 40	
14	5100004367	2	PC	Buche Buje	Bush Boîte		
15	5100005541	1	PC	Arretierung Dispositivo de retención	Lock Dispositif d'arrêt		
16	5000129818	2	PC	Gummi-Metall-Puffer Tope caucho-metal	Shockmount Tampon métallique oscillant		
17	5000010742	2	PC	Scheibe Arandela	Washer Rondelle		
18	5000011543	2	PC	Zylinderchraube Tornillo hueco	Socket head screw Vis à six-pans creux	M8 x 20 24Nm/18ft.lbs	ISO4762
19	5100010497	4	PC	Gummipuffer Tope caucho-metal	Shockmount Tampon oscillant		
20	5000010882	4	PC	Sechskantmutter Tuerca hexagonal	Hexagon nut Écrou hexagonal		
21	5100005526	1	PC	Flanch Brida	Flange Bride		
22	5000069225	1	PC	Einraubtutzen Empalme roscado	Screwed socket Manchon visse		
23	5100005553	1	PC	Schlauchleitung Conducto flexible	Hose pipe Conduite flexible		
24	5100027083	1	PC	Deichkopf Kpl. Cabezal de mando cpl.	Center pole head cpl. Tête de timon cpl.		
25	5000011539	4	PC	Zylinderchraube Tornillo cilíndrico	Cheese head screw Vis à tête cylindrique	M8 x 40 25Nm/18ft.lbs	ISO4762
26	5000215035	2	PC	Gummi-Metall-Puffer Tope caucho-metal	Shockmount Tampon métallique oscillant		
27	5000011527	2	PC	Zylinderchraube Tornillo cilíndrico	Cheese head screw Vis à tête cylindrique		
28	5100005124	1	PC	Bügel Abrazadera	Clamp Attache		

Center pole cpl.
Barra de mando cpl.
Timon cpl.
Deichel Kpl.

DPU6555HEC

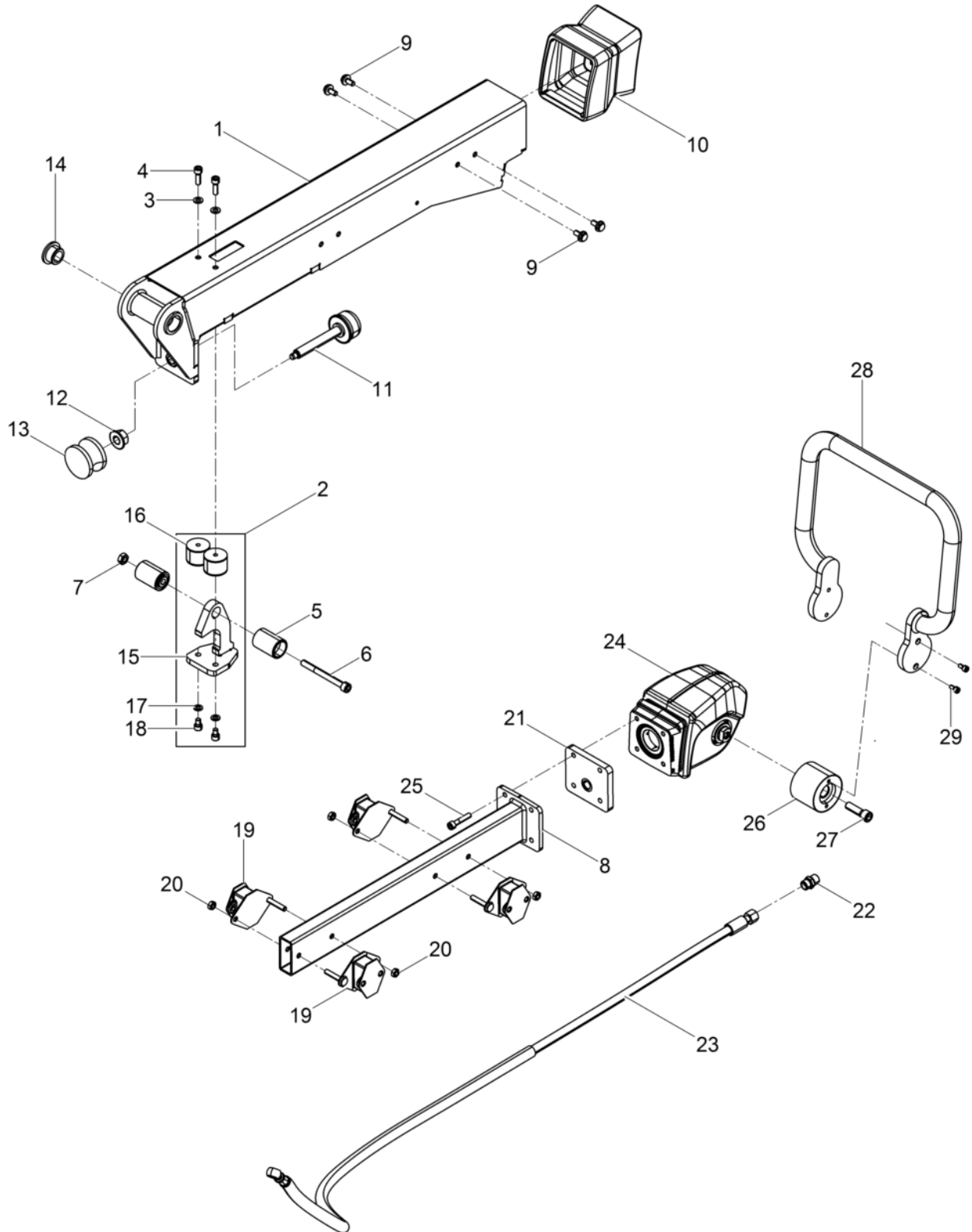

Pos. Ref.	Artikel Nr. Part No.	Qty.	Unit	Beschreibung Descripcion	Description Description	Abm. Measuram.	Norm Standard
						Drehm. Torque	Schmierstoff Sealant
29	5000011554	4	PC	Zylinderchraube Tornillo cilíndrico	Cheese head screw Vis à tête cylindrique		

Center pole head cpl.
Cabezal de mando cpl.
Tête de timon cpl.
Deichelkopf Kpl.

DPU6555HEC

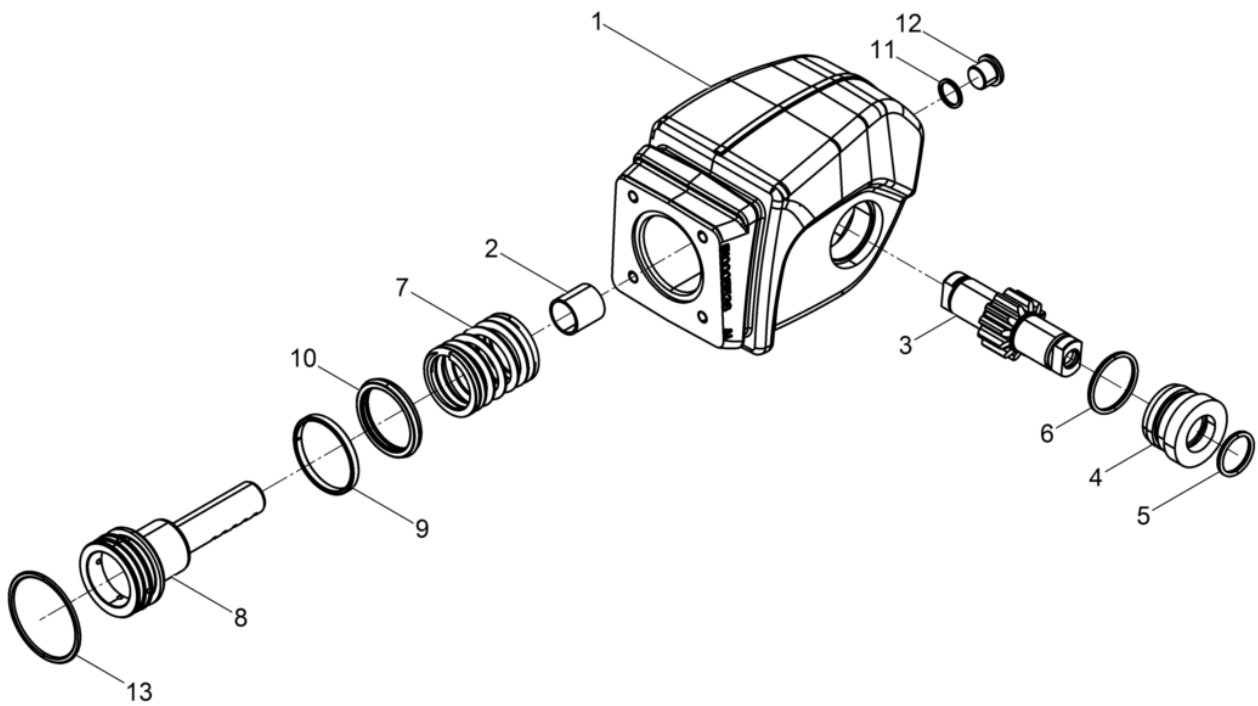

Pos. Ref.	Artikel Nr. Part No.	Qty.	Unit	Beschreibung Descripción	Description Description	Abm. Measur.	Norm Standard
						Drehm. Torque	Schmierstoff Sealant
1	5100005537	1	PC	Deichelkopf Cabezal de barra	Center pole head Tête de timon		
2	5000126164	1	PC	Gleitbuche Buje deslizante	Slide bush Bôte de glissement		
3	5000069726	1	PC	Zahnradwelle Eje de rueda dentada	Long face pinion Arbre formant pignon		
4	5000125926	2	PC	Distanztück Pieza distanciadora	Spacer Pièce d'écartement		
5	5000018194	2	PC	O-Ring Anillo-o	O-ring Bague-o		
6	5000068752	2	PC	O-Ring Anillo-o	O-ring Bague-o		
7	5100005559	1	PC	Druckfeder Resorte de compresión	Compression spring Ressort de pression		
8	5100005138	1	PC	Steuerkolben Pistón de mando	Control piston Piston de commande		
9	5100005532	1	PC	Führungring Anillo guía	Guide ring Bague de guidage	KB 55x50x5,5 HG517	
10	5100005533	1	PC	Dichtung Junta	Gasket Joint		
11	5000012082	1	PC	Dichtungring Anillo sellador	Seal ring Rondelle à étancher	A16 x 20	DIN7603
12	5000011050	1	PC	Verchlußschraube Tapón roscado	Plug (threaded) Bouchon	M16 x 1,5	DIN908
13	5000039235	1	PC	O-Ring Anillo-o	O-ring Bague-o	58 x 3	

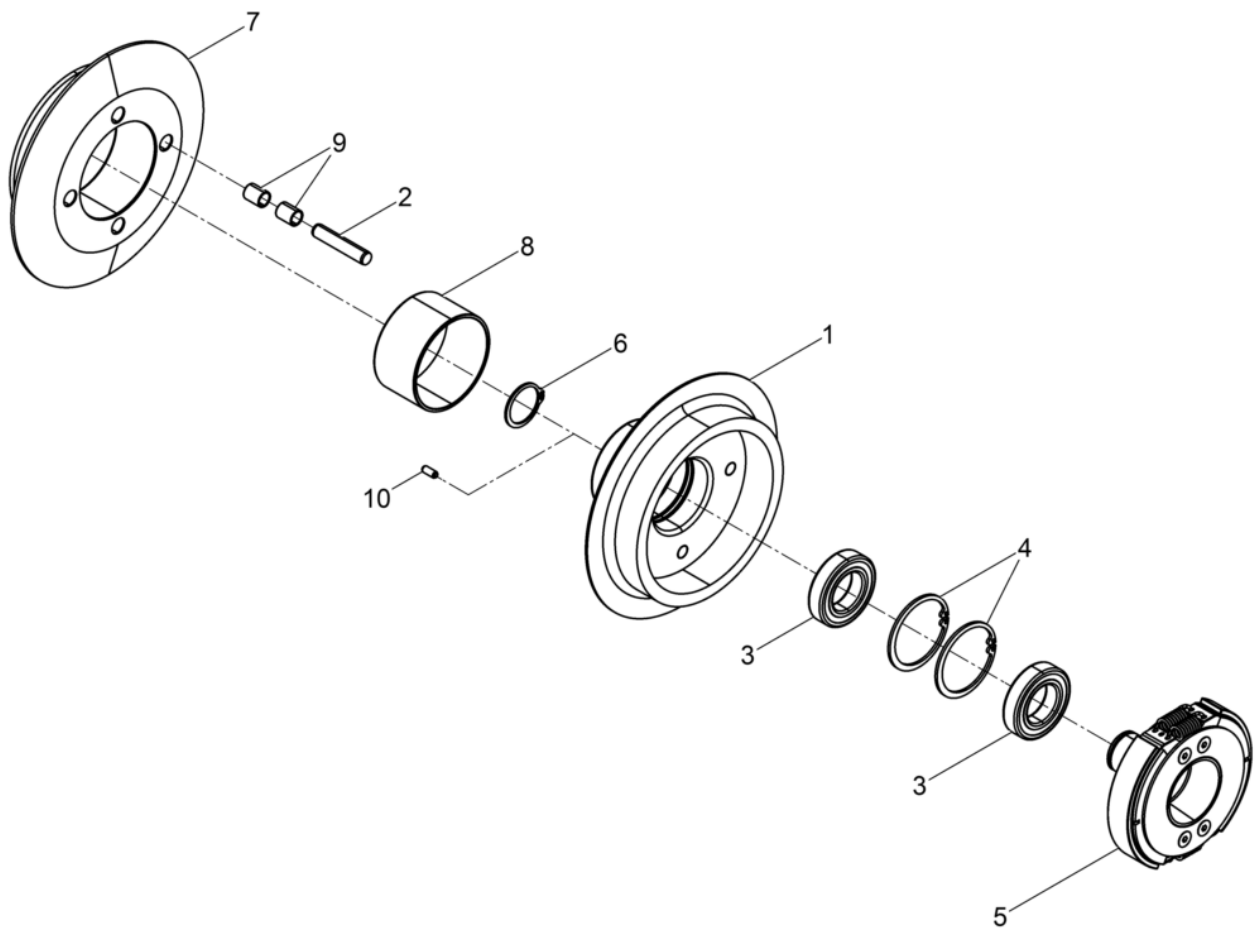

Pos. Ref.	Artikel Nr. Part No.	Qty.	Unit	Beschreibung Description	Description Description	Abm. Measur.	Norm Standard
						Drehm. Torque	Schmierstoff Sealant
1	5000058541	1	PC	Kupplungsglocke Campana del embrague	Clutch drum Cloche de rentrée	49Nm/36ft.lbs	
2	5000058539	4	PC	Stift Espiga	Pin Goupille		
3	5000039999	2	PC	Rillenkugellager Rodamiento a bolas	Grooved ball bearing Roulement rainuré à billes		
4	5002003826	2	PC	Sicherungring Anillo de retención	Retaining ring Bague d'arrêt	55 x 2	DIN472
5	5000201992	1	PC	Fliehkraftkupplung Embrague	Centrifugal clutch Embrayage		
6	5002001815	1	PC	Sicherungring Anillo de retención	Retaining ring Bague d'arrêt	30 x 1,5	DIN471
7	5000058540	1	PC	Keilriemencheibe Polea en v	V-belt pulley Poulie à courroie		
8	5000058536	1	PC	Buche Buje	Bushing Boîte	70 ID	
9	5000058551	8	PC	Buche Casquillo	Bush Bôte	10 ID	
10	5000013591	2	PC	Spanntift Pasador de sujeción	Spring pin Goupille élastique	5 x 12	DIN1481

Centrifugal clutch cpl.
Embrague centrifugo cpl.
Embrayage centrifuge cpl.
Fliehkraftkupplung Kpl.

DPU6555HEC

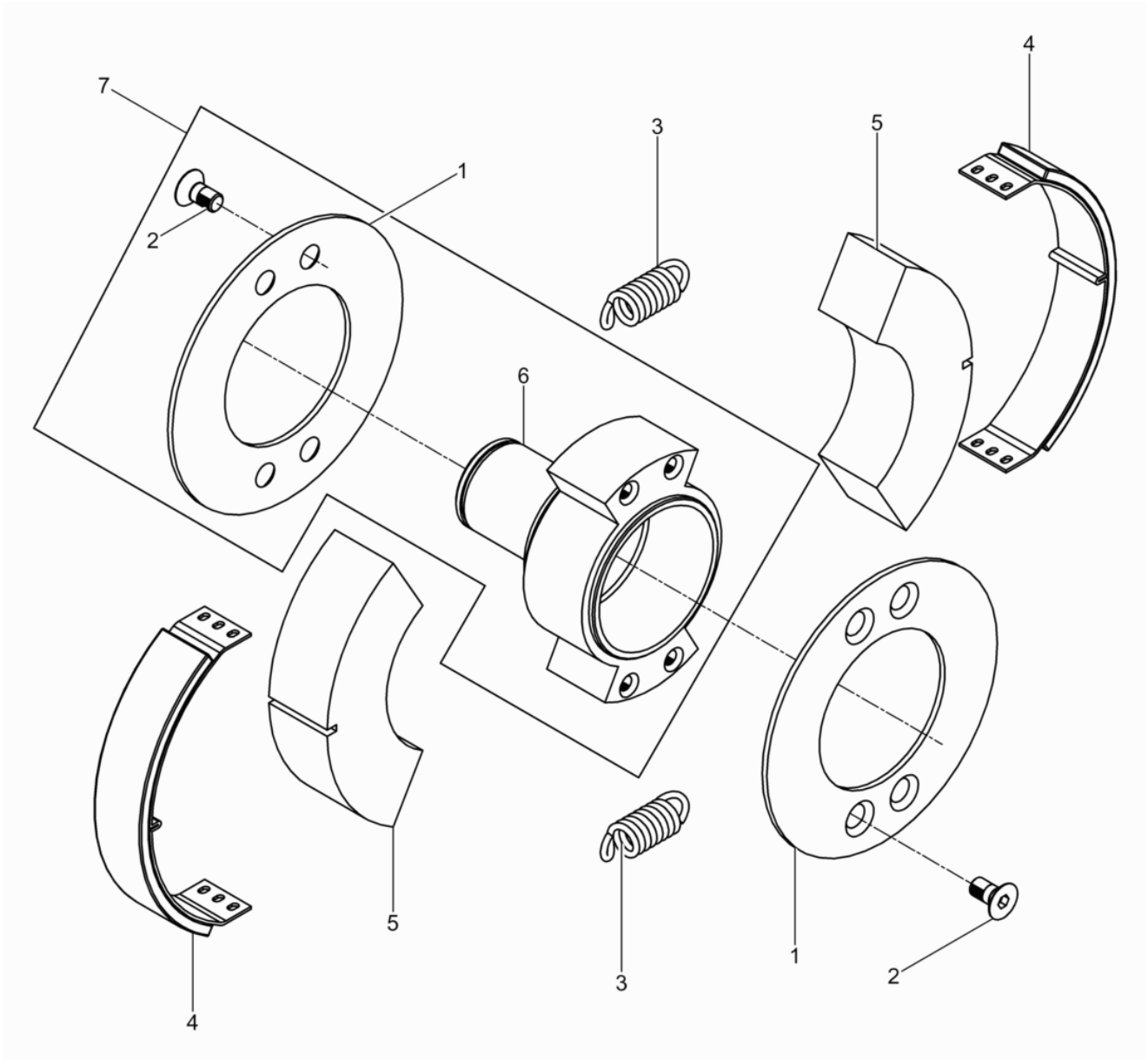

Pos. Ref.	Artikel Nr. Part No.	Qty.	Unit	Beschreibung Descripción	Description Description	Abm. Measur.	Norm Standard
						Drehm. Torque	Schmierstoff Sealant
1	5000201994	2	PC	Fixiercheibe Arandela de retención	Fixing disc Rondelle de fixation		
2	5000024338	8	PC	Senkchraube Tornillo avellanado	Countersunk screw Vis noyée	M6 x 10	DIN963
3	5000045979	4	PC	Zugfeder Resorte de tracción	Tension spring Ressort de traction		
4	5002006075	2	PC	Belagträger Zapata	Lining Garniture d'embrayage		
5	5000049506	2	PC	Fliehgewicht Peso centrifugo	Centrifugal weight Poids centrifuge		
6	5000201993	1	PC	Nabe Cubo	Hub Moyeu		
7	5000203003	1	PC	Nabenatz Juego de cubo	Hub kit Jeu de moyeu		

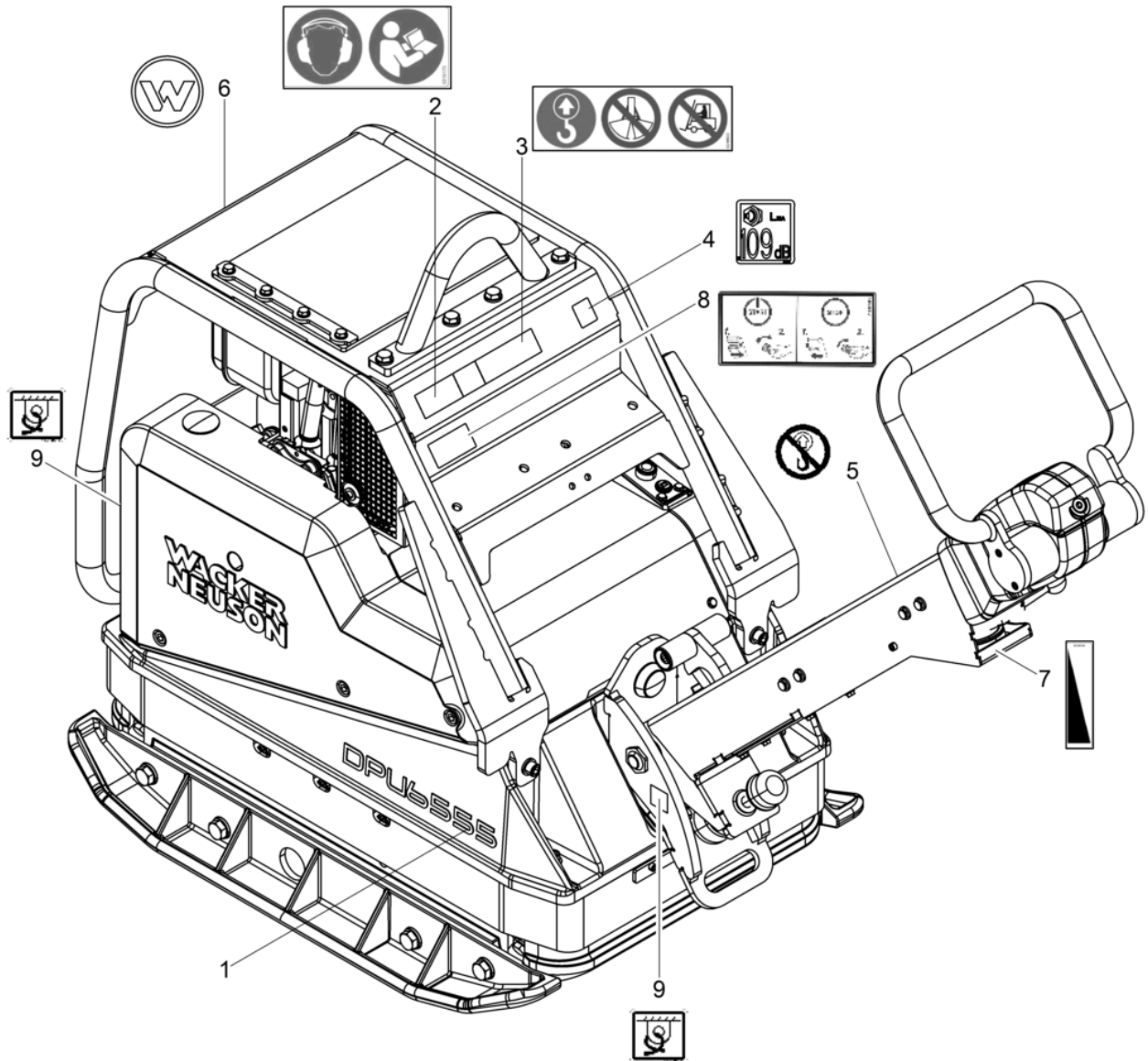

Pos. Ref.	Artikel Nr. Part No.	Qty.	Unit	Beschreibung Descripción	Description Description	Abm. Measur.	Norm Standard
						Drehm. Torque	Schmierstoff Sealant
1	5000220386	2	PC	Aufkleber-Typ Tipo etiqueta autoadhesiva	Type label Autocollant de type		
2	5000219175	1	PC	Aufkleber Calcomanías	Labels Autocollants		
3	5000216633	1	PC	Aufkleber-Hinwei Calcomanía-indicación	Instruction label Autocollant avec indication		
4	5000064925	1	PC	Aufkleber-Schalleitungpegel Etiqueta autoadhesiva-nivel de potencia acúëstica	Decal-sound power level Autocollante-niveau sonore		
5	5000220000	1	PC	Aufkleber-Warnhinwei Calcomanía-indicación	Instruction label Autocollant avec indication		
6	5000222085	1	PC	Aufkleber Symbol Calcomanía símbolo	Label symbol Autocollant symbole		
7	5000219259	1	PC	Aufkleber Calcomanías	Labels Autocollants		
8	5100026807	1	PC	Aufkleber (Start Stop) Calcomanías (start stop)	Labels (start stop) Autocollants (start stop)		
9	1000184310	3	PC	Aufkleber Calcomanía	Label Autocollant		

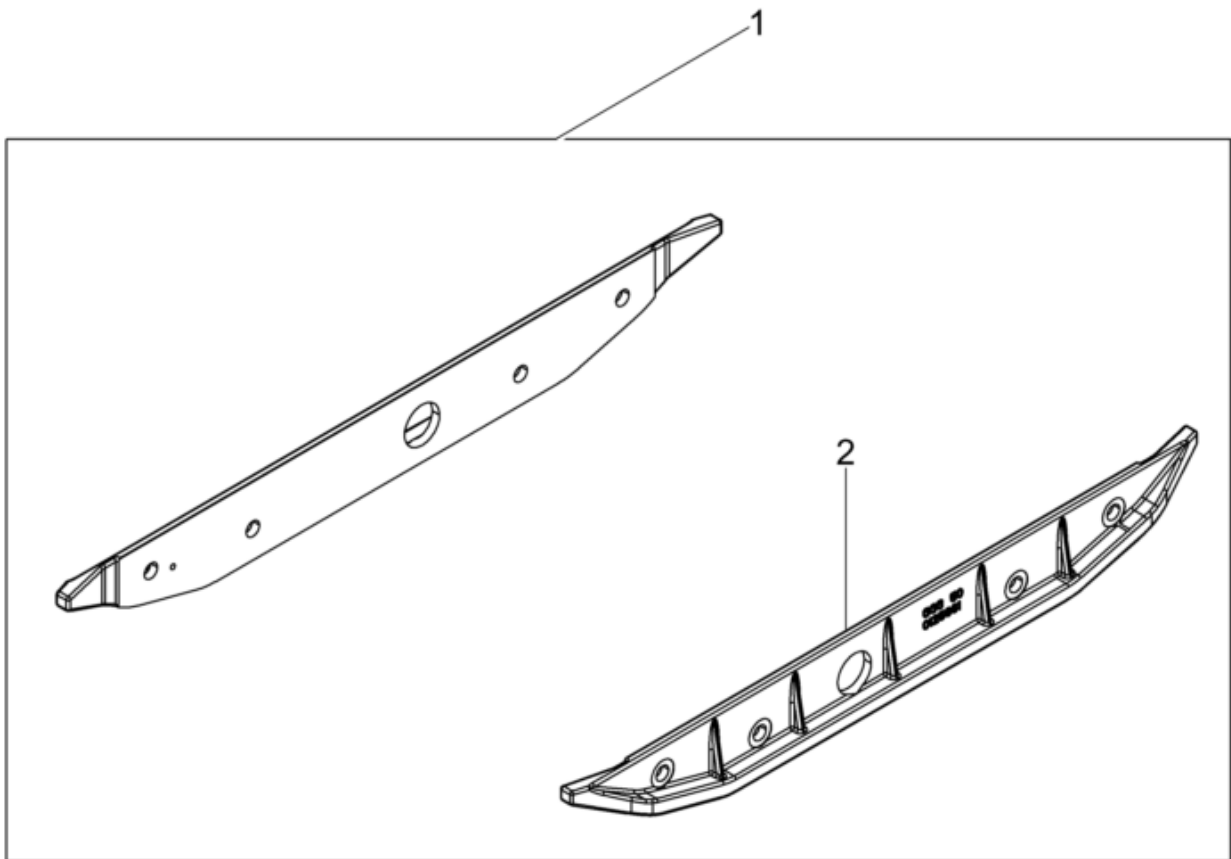

Pos. Ref.	Artikel Nr. Part No.	Qty.	Unit	Beschreibung Descripción	Description Description	Abm. Measur.	Norm Standard
						Drehm. Torque	Schmierstoff Sealant
1	5000126290	1	PC	Anbauplattenatz Juego de placa de extensión	Extension plate kit Jeu de elargisseur	3	
2	5000125662	2	PC	Anbauplatte Placa de extensión	Extension plate Elargisseur	3 cm	

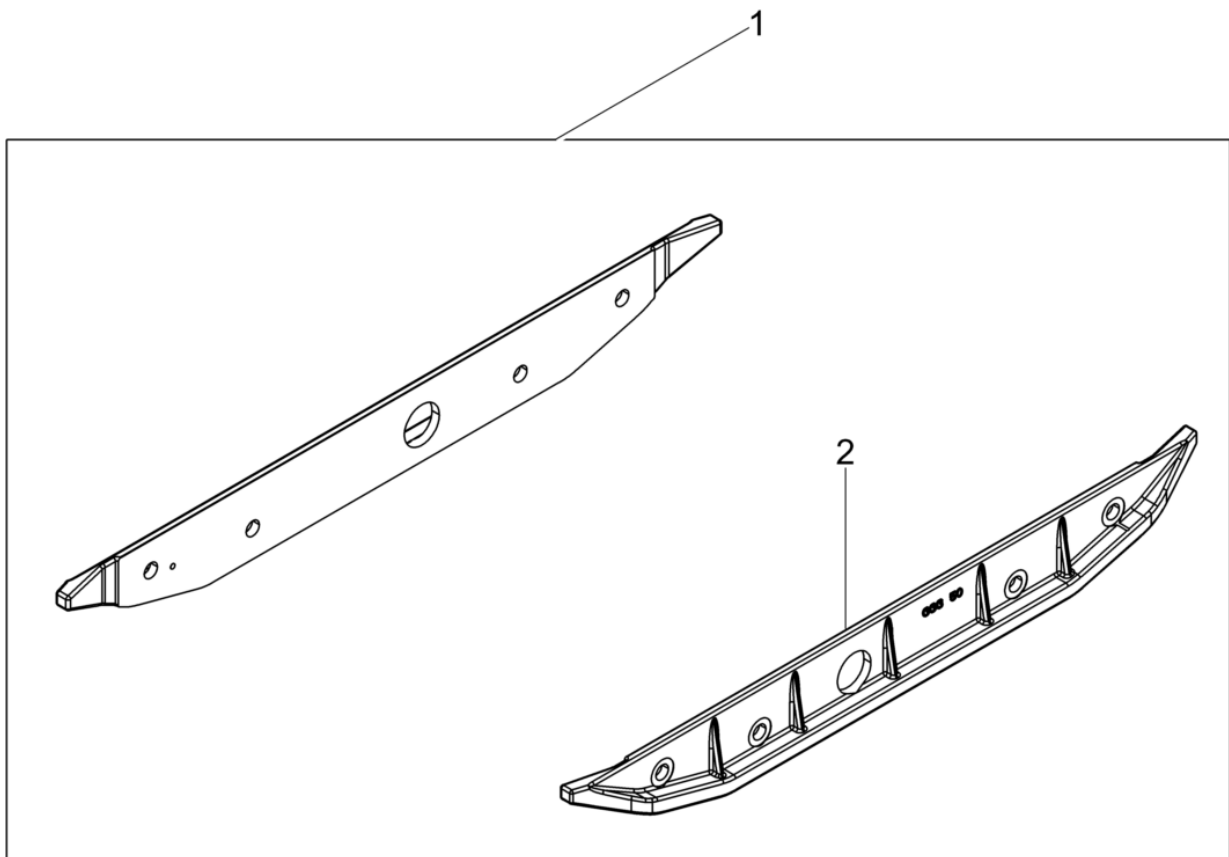

Pos. Ref.	Artikel Nr. Part No.	Qty.	Unit	Beschreibung Descripción	Description Description	Abm. Measur.	Norm Standard
						Drehm. Torque	Schmierstoff Sealant
1	5000045201	1	PC	Anbauplattenatz Juego de placa de extensión	Extension plate kit Jeu de elargisseur	3in	
2	5000044442	2	PC	Anbauplatte Placa de extensión	Extension plate Elargisseur	8 cm	

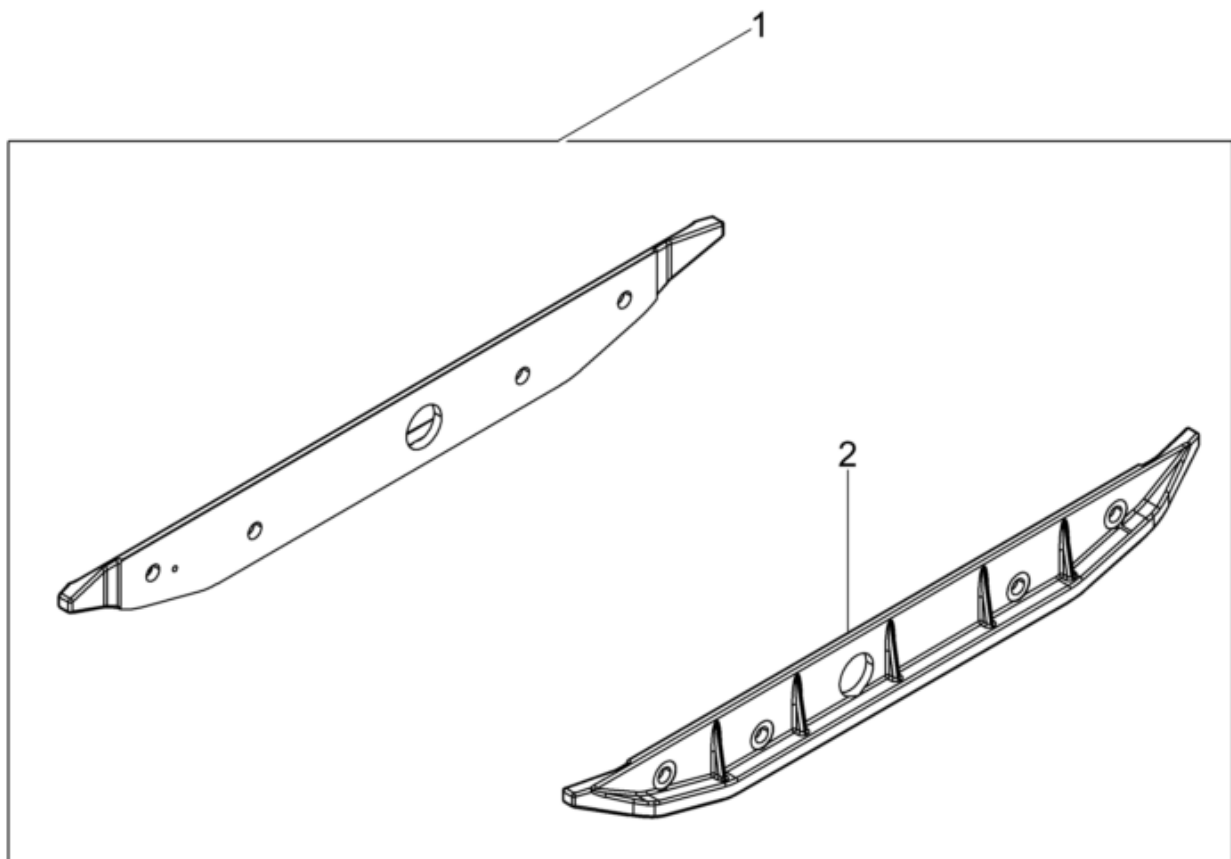

Pos. Ref.	Artikel Nr. Part No.	Qty.	Unit	Beschreibung Descripción	Description Description	Abm. Measur.	Norm Standard
						Drehm. Torque	Schmierstoff Sealant
1	5000043246	1	PC	Anbauplattenatz Juego de placa de extensión	Extension plate kit Jeu de elargisseur	15	
2	5000043245	1	PC	Anbauplatte Placa de extensión	Extension plate Elargisseur	860mm	

1

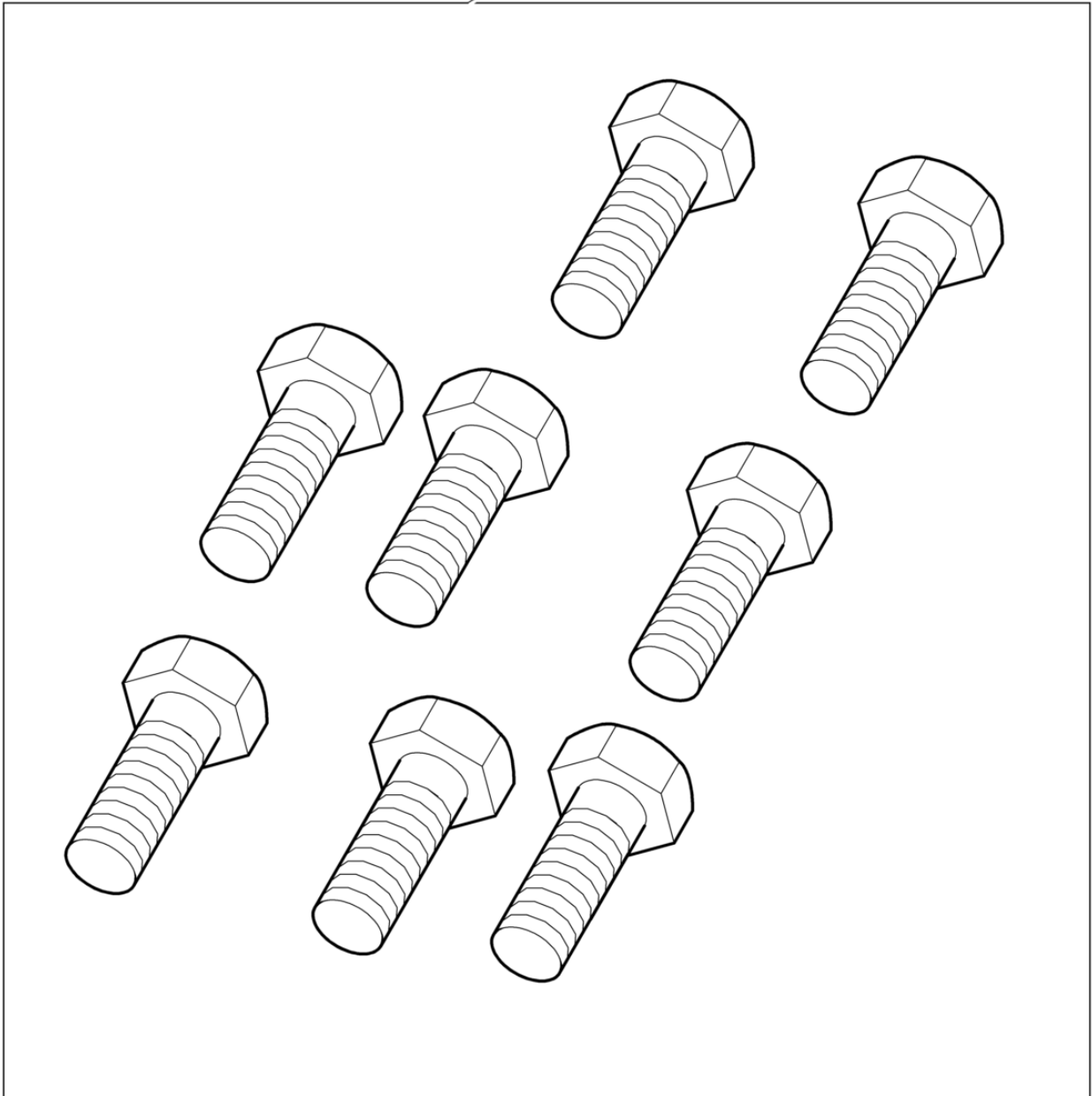

DPU6555HEC**Schraubenatz
Set of screws
Juego de tornillos
Jeu de vis**

Pos. Ref.	Artikel Nr. Part No.	Qty.	Unit	Beschreibung Descripcion	Description Description	Abm. Measuram.	Norm Standard
						Drehm. Torque	Schmierstoff Sealant
1	5000067519	1	PC	Schraubenatz Juego de tornillos	Set of screws Jeu de vis		



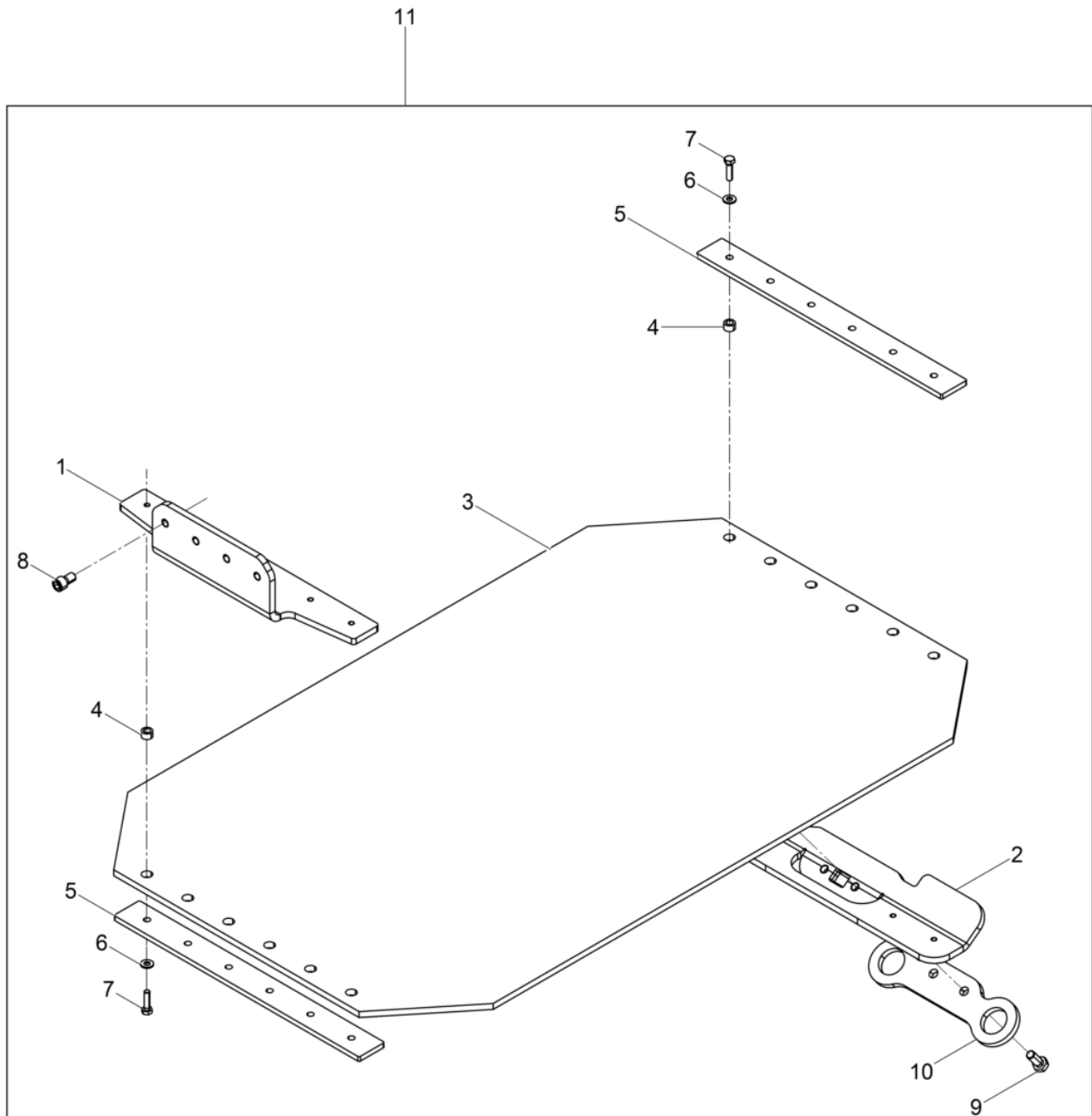

Pos. Ref.	Artikel Nr. Part No.	Qty.	Unit	Beschreibung Descripción	Description Description	Abm. Measur.	Norm Standard
						Drehm. Torque	Schmierstoff Sealant
1	5000205208	1	PC	Winkel Angulo delantera	Front angle Angle de front		
2	5100010936	1	PC	Winkel Hinten Angulo atrás	Angle rear Angle arrière		
3	5000205209	1	PC	Kunstoffplatte Juego de lamina de uretano	Urethane plate Dispositif de glissement		
4	5000047577	10	PC	Buche Buje	Bushing Douille		
5	5000058358	2	PC	Leite Listón	Bar Listeau		
6	5000033198	10	PC	Spanncheibe Arandela elástica	Lockwasher Rondelle de ressort	8	DIN6796
7	5000011456	10	PC	Sechskantchraube Tornillo hexagonal	Hexagonal head cap screw Vis à tête hexagonale		
8	5000011531	4	PC	Zylinderchraube Tornillo cilíndrico	Cheese head screw Vis à tête cylindrique	M12 x 20 86Nm/63ft.lbs	ISO4762
9	5000011423	2	PC	Sechskantchraube Tornillo hexagonal	Hexagonal head cap screw Vis à tête hexagonale	M12 x 30 210Nm/155ft.lbs	DIN933
10	5100010935	1	PC	Blech Chapa	Plate Tôle		
11	5100009998	1	PC	Gleitvorrichtung Placa de deslizamiento pgv dpu 6555	Urethane pad kit pgv dpu 6555 Jeu de tapis en polyuréthane		

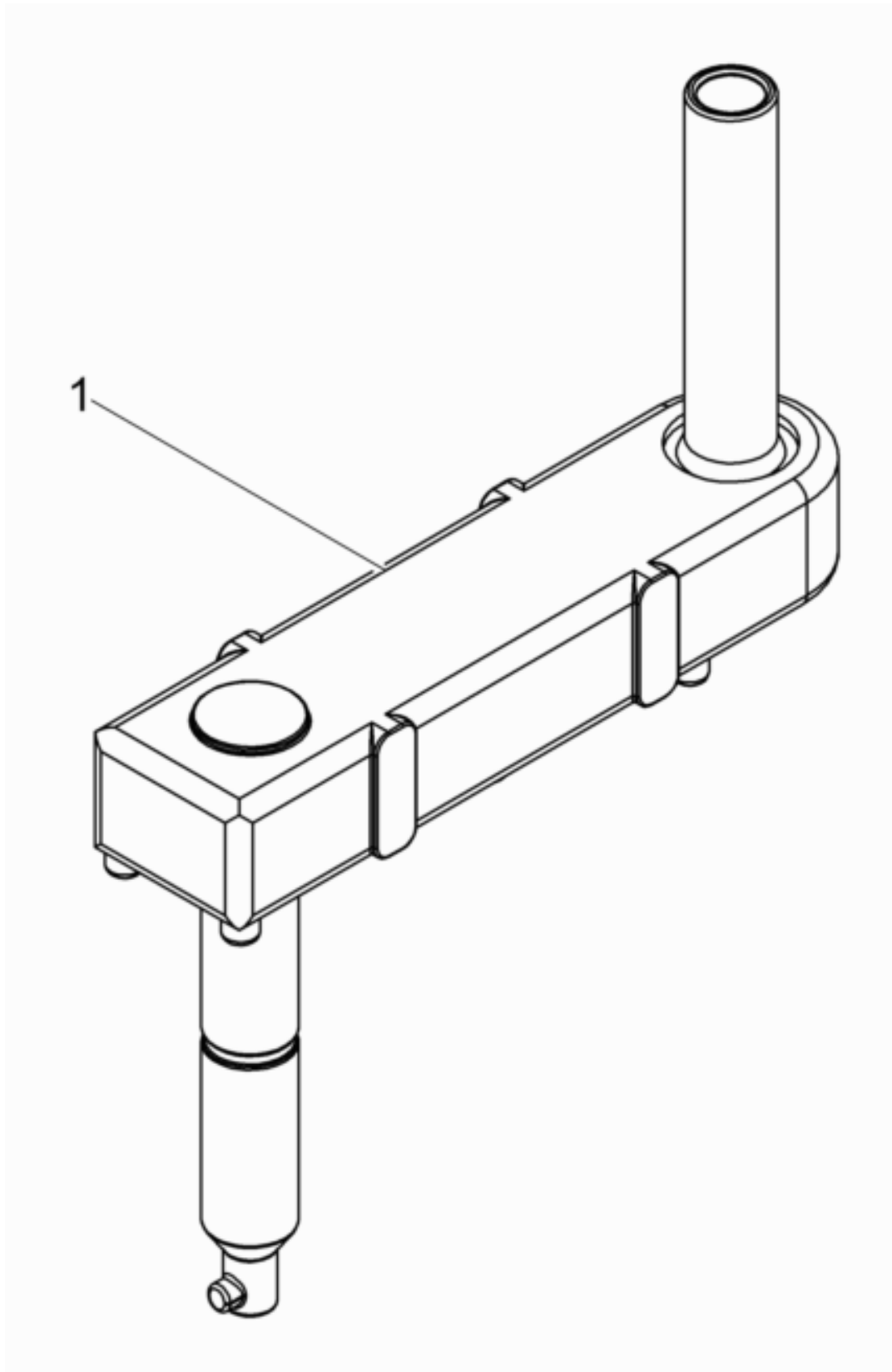

Pos. Ref.	Artikel Nr. Part No.	Qty.	Unit	Beschreibung Descripcion	Description Description	Abm. Measuram.	Norm Standard
						Drehm. Torque	Schmierstoff Sealant
1	5000095187	1	PC	Andrehkurbel Rückchlaglicher Manivela de arranque	Starting crank Manivelle de démarrage		

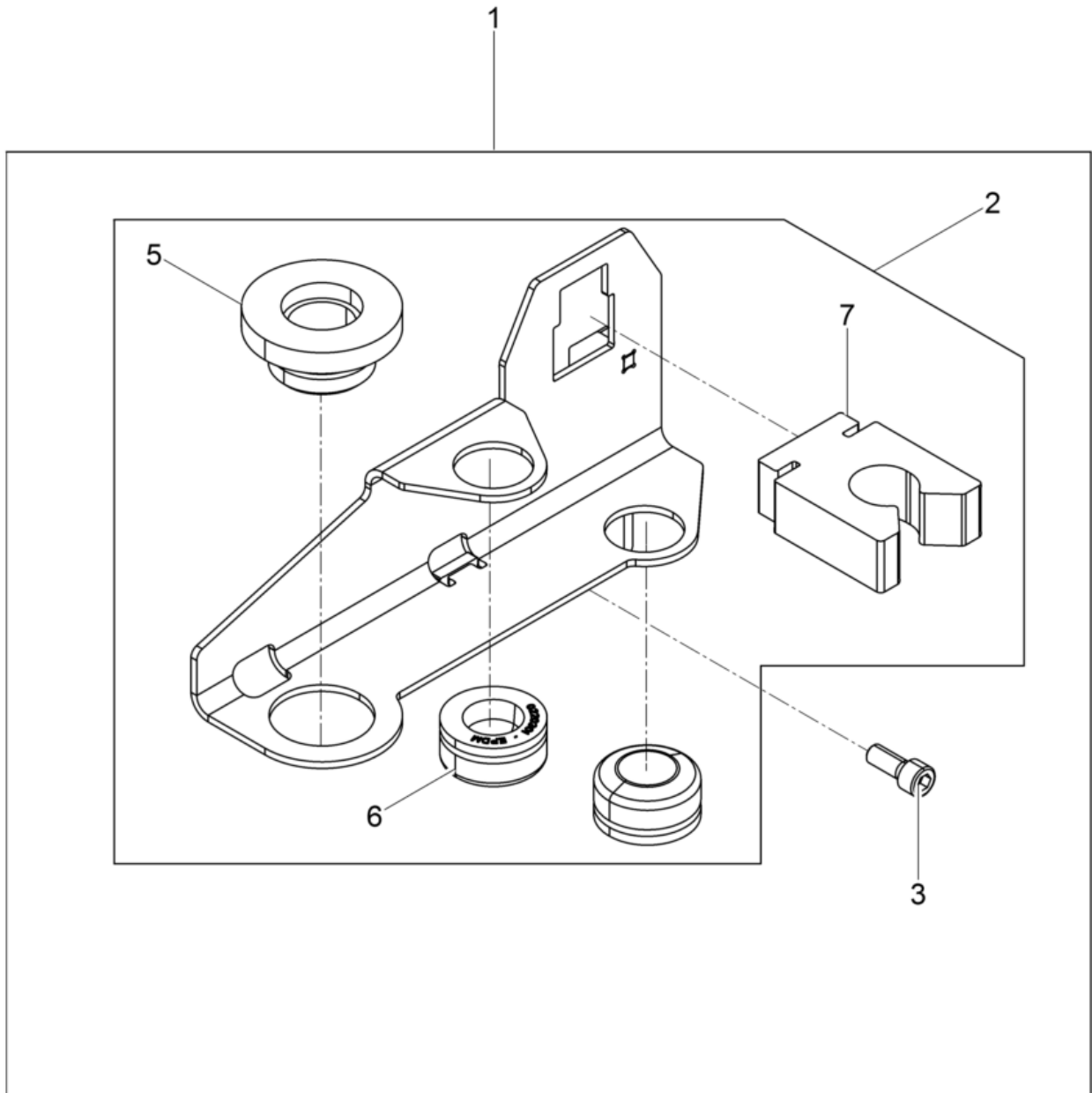

Pos. Ref.	Artikel Nr. Part No.	Qty.	Unit	Beschreibung Descripción	Description Description	Abm. Measur.	Norm Standard
						Drehm. Torque	Schmierstoff Sealant
1	5000220473	1	PC	Anbauatz Juego-instalación-manivela de arranque	Kit-mounting-starting crank Jeu de montage-manivelle de		
2	5100003970	1	PC	Kurbelhalter Kpl. Porta-manivela cpl.	Crank holder cpl. Support manivelle cpl.		
3	5000011535	2	PC	Zylinderchraube Tornillo cilíndrico	Cheese head screw Vis à tête cylindrique		
5	5000220300	1	PC	Gummibuche Buje	Bush Boîte		
6	5000220301	2	PC	Puffer Amortiguador	Shockmount Silentbloc		
7	5000220239	1	PC	Halterung Soporte	Bracket Équerre		

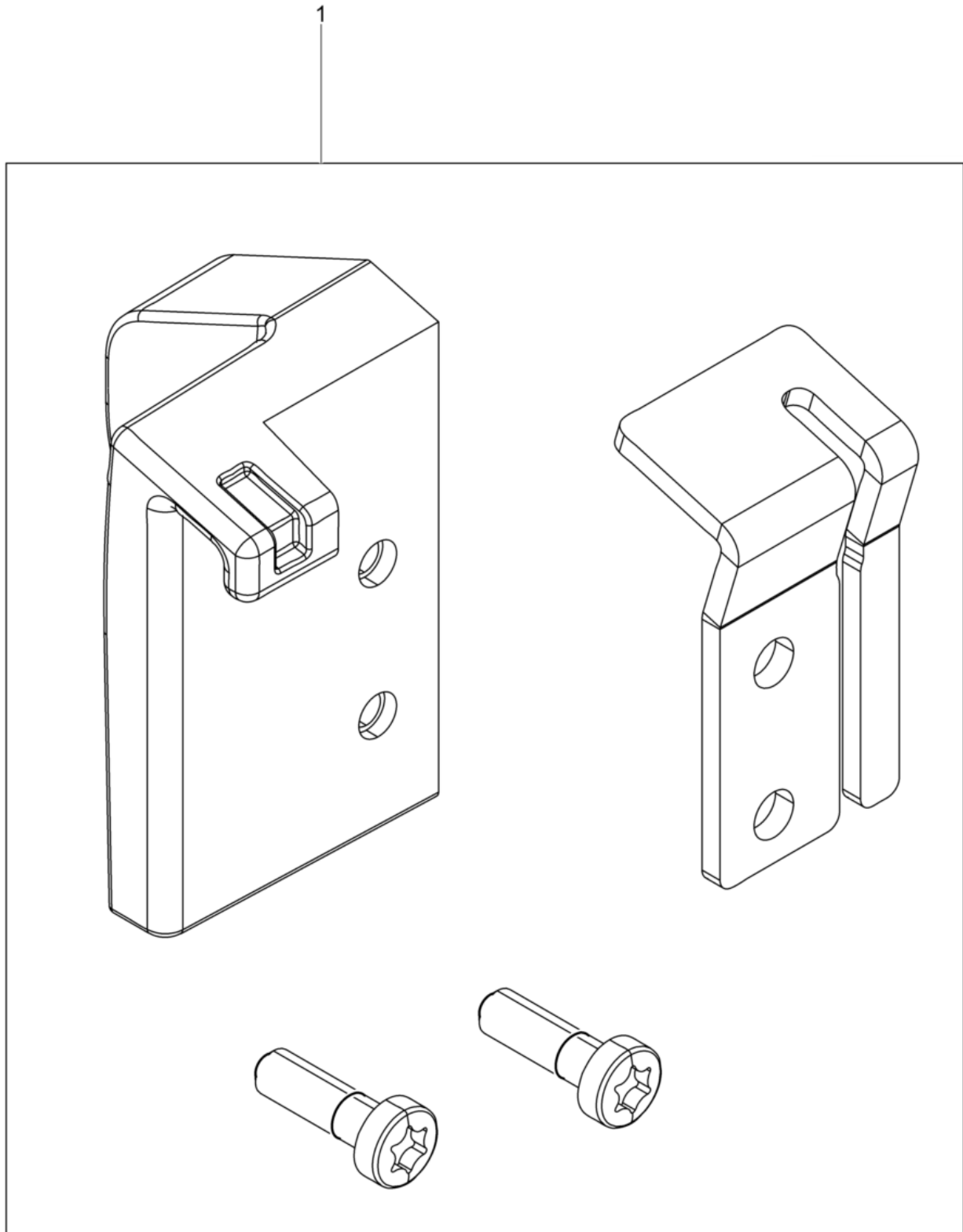

Pos. Ref.	Artikel Nr. Part No.	Qty.	Unit	Beschreibung Descripción	Description Description	Abm. Measur.	Norm Standard
						Drehm. Torque	Schmierstoff Sealant
1	5100005821	1	PC	NachrüTatz Riemenberuhiger Juego de modificguía de correa	Kit-retrofit belt guide Lot de rattrapag		

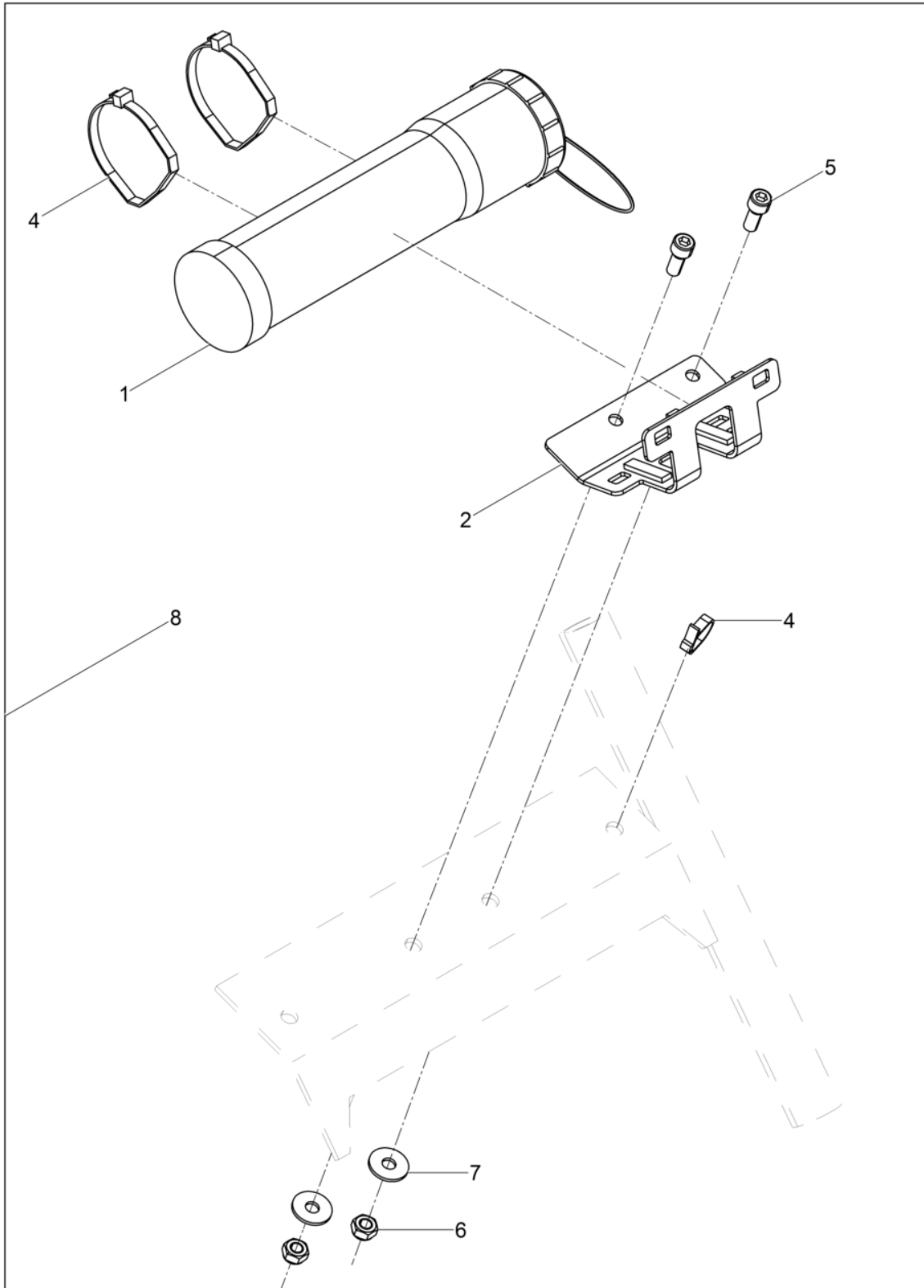

Pos. Ref.	Artikel Nr. Part No.	Qty.	Unit	Beschreibung Descripcion	Description Description	Abm. Measur.	Norm Standard
						Drehm. Torque	Schmierstoff Sealant
1	5100026895	1	PC	Dokumentenbehälter Saporte posa documentos	Document-box Receptable de documents		
2	5100027192	1	PC	Halterung Soporte	Bracket Équerre		
4	5000047388	3	PC	Kabelbinder Fijación de cables	Cable yarn Attache de câble		
5	5000011535	2	PC	Zylinderchraube Tornillo cilíndrico	Cheese head screw Vis à tête cylindrique	49Nm/36ft.lbs	
6	5000017313	2	PC	Sechskantmutter Tuerca hexagonal	Hexagon nut Écrou hexagonal		
7	5000010375	2	PC	Scheibe Arandela	Flat washer Rondelle	B10,5	DIN9021
8	5100027238	1	PC	NachrüTatz Rental DPU6555 Juego de modificación rental dpu6555	Kit-retrofit rental dpu6555 Lot de rattrapage		



**WACKER
NEUSON**

