



**WACKER
NEUSON**

5100015773	100
02.2016	

**Reversible Plates
Reversierbare Platten
Planchas Reversibles
Plaques réversible**

DPU 6555Hs

**Parts Book
Ersatzteile
Lista de Repuestos
Liste de Pièces de Rechange**

www.wackerneuson.com

A nameplate listing the Model Number, Item Number, Revision, and Serial Number is attached to each unit. Please record the information found on this plate so it will be available should the nameplate become lost or damaged. When ordering parts or requesting service information, you will always be asked to specify the model, item number, revision number, and serial number of the unit.

Ein Typenschild mit Typ, Artikelnummer, Version und Maschinen-Nummer ist an jedem Gerät angebracht. Die Daten von diesem Schild bitte notieren, damit sie auch bei Verlust oder Beschädigung des Schildes noch vorhanden sind. Der Typ, die Artikel-Nummer, die Versions- Nummer und die Maschinen-Nummer sind bei der Ersatzteilbestellung oder Nachfragen bezüglich Service-Informationen stets erforderlich.

Una placa de identificación con el modelo, número de referencia, nivel de revisión y número de serie ha sido añadida en cada máquina. Favor de anotar los datos en la placa en caso de que la placa de identificación sea destruida o perdida. En todos los pedidos para repuestos necesita siempre el modelo, el número de referencia, el nivel de revisión y el número de serie de la máquina en cuestión.

Une plaque signalétique mentionnant le modèle, le numéro de référence, le niveau de révision et le numéro de série est fixée sur chaque machine. Veuillez noter les informations relevées sur cette plaque de façon à ce qu'elles soient toujours disponibles si la plaque signalétique venait à être perdue ou endommagée. Lorsque vous commandez des pièces détachées ou vous sollicitez des informations après-vente, on vous demandera toujours de préciser le modèle, le numéro de référence, le niveau de révision et le numéro de série de la machine.

***My machine's numbers are / Die Nummern meines Gerätes sind /
Los números de mi máquina son / Les numéros de ma machine son :***

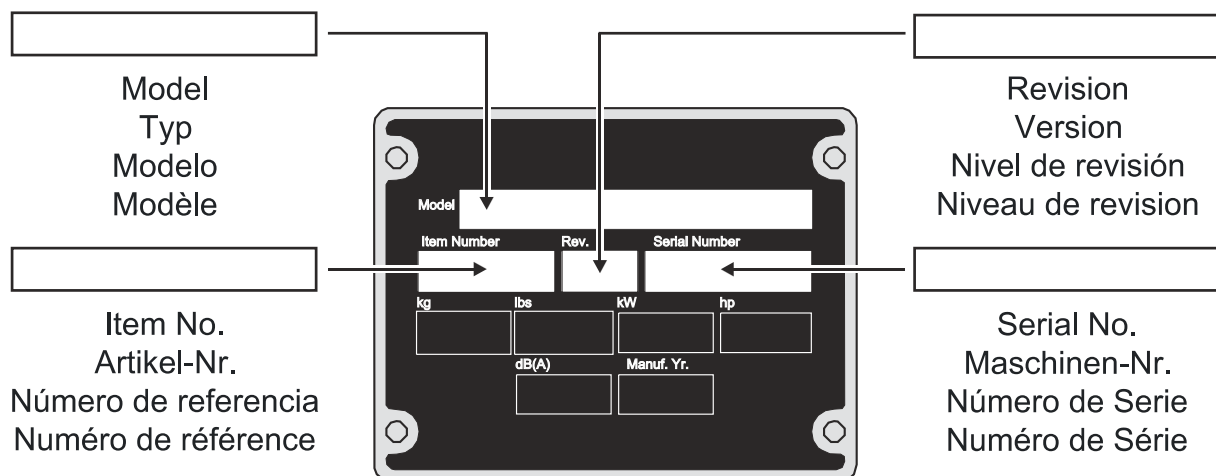

Part Numbers appearing in boldface type are recommended spare parts. This means that these parts are subject to wear under normal operating conditions and may require periodic service or replacement. It is recommended that these items be stocked to meet the expected service requirements of this model. Actual stocking quantities of these and other parts used in more extensive repairs will depend on the service practices of each customer.

Bei den in den Ersatzteillisten fettgedruckten Nummern handelt es sich um empfohlene Ersatzteile. Dies bedeutet, daß diese Teile bei normalen Anwendungsbedingungen natürlicher Abnutzung ausgesetzt sind und gelegentlich ersetzt oder überarbeitet werden müssen. Es wird geraten, diese Teile auf Lager bereit zu haben, um für Service-Arbeiten an diesem Gerät vorbereitet zu sein. Lagerbestände für diese und andere Teile, welche für ausgiebigere Reparaturarbeiten benötigt werden, können je nach Service-Gewohnheiten der einzelnen Kunden variieren.

Los números de partes en negritas en las Listas Ilustradas de Partes son los repuestos recomendados, ésto quiere decir que estas partes se desgastarán bajo circunstancias de funcionamiento normales y pueden requerir servicio periódico o su reemplazo. Se recomienda que el cliente mantenga un abastecimiento adecuado de estas partes para poder satisfacer la demanda requerida por el servicio a la máquina. La cantidad de repuestos que el cliente necesitará para reparaciones dependerá de la póliza de servicio de cada cliente.

Les numéros de pièces imprimés en caractères gras dans les Listes des Pièces Détachées de ce manuel sont les pièces détachées recommandées par la Wacker. Cela veut dire que ces pièces sont sujettes à usure dans des conditions de travail normales et peuvent nécessiter de l'entretien ou leur remplacement. Nous recommandons que vous disposez d'un stock de ces pièces pour pouvoir satisfaire la demande d'entretien de cette machine. Le client doit décider lui-même de la quantité exacte de pièces de rechange qu'il disposera dans ses stocks.

Vibration Plate Vibrationsplatte Plancha Vibradora Plaque Vibrante	8
Vibration Plate Vibrationsplatte Plancha Vibradora Plaque Vibrante	10
Upper mass Obermasse Masa Superior Masse Superieure	12
Baseplate Untermasse Masa inferior Masse inferieure	16
Exciter Erreger Excitador Excitatrice	18
Center Pole cpl. Deichsel kpl. Barra de mando cpl. Timon cpl.	22
Center Pole Head cpl. Deichselkopf kpl. Cabezal de mando cpl. Tête de timon cpl.	26
Coupling cpl. Kupplung kpl. Embrague cpl. Embrayage cpl.	28
Centrifugal Clutch cpl. Fliehkraftkupplung kpl. Embrague centrifugo cpl. Embrayage centrifuge cpl.	30
Labels Aufkleber Calcomanías Autocollants	32
Labels US Autocollants US Calcomanías US Autocollants US	34
Engine Motor Motor Moteur	37
Crankcase Kurbelgehäuse Cárter Carter	38
Crankcase Kurbelgehäuse Cárter Carter	40

Indice

Table des matières

Crankshaft - Mounting flange Kurbelwelle-Lagerflansch Cigüeñal - Brida Vilebrequin - Bourrelet	44
Camshaft Nockenwelle Árbol de Levas Arbre à Cames	46
Piston-Connecting Rod-Cylinder Kolben-Pleuel-Zylinder Pistón-Biela-Cilindro Piston-Bielle-Cylindre	48
Cylinder head Zylinderkopf Tapa del cilindro Culasse	50
Push rod-Fly wheel Stoßstange-Schwungrad Varilla de empuje-Volante Poussoir-Volant	56
Oil Pump-Governor Ölpumpe-Regler Bomba de Aceite-Regulador Pompe à Huile-Régulateur	58
Command Cover Steuerdeckel Tapa del mando Couvercle de commande	60
Extra Fuel Device - Special Equipment Startfüllung-Einspritzausrüstung Sobrealimentación-Arranque - Accesorios Surcharge - Des extra	62
Air Ducting Luftführung Conducción de Aire Carter Ventilation	66
Breather - Governor Entlüftung-Drehzahlverstellung Purgado - Regulador de Revoluciones Raccord Fileté de Purge -	68
Fuel System Kraftstoffsystem Sistema de Combustible Système d'Essence	72
Air Cleaner Luftfilter Filtro del Aire Filtre à Air	76
Exhaust Silencer Abgasdämpfer Silenciador Silencieux	80
Starting crank Andrehkurbel Manivela de arranque Manivelle de démarrage	82

Oil drain Ölablaß Drenaje de aceite Raccord vidange d'huile	84
Automatic shut-off mech. Abschaltautomatik mech. Cierre automático Interruption automatique	86
Coupling housing Anschlußgehäuse Caja de conexión Carter de branchement	88
Engine Equipment EPA Motorausrüstung EPA Equipamiento de Motor EPA Equipement Moteur EPA	90
Spare Parts Kits Ersatzteilsätze Juegos de Repuestos Jeu de Pièces de Rechange	92
Accessoires Zubehör Accesorios Accessories	95
Extension plate kit Anbauplatten-Satz Juego de placa de extensión Jeu de elargisseur	96
Extension plate kit Anbauplatten-Satz Juego de placa de extensión Jeu de elargisseur	98
Extension plate kit Anbauplatten-Satz Juego de placa de extensión Jeu de elargisseur	100
Set of screws Schraubensatz Juego de tornillos Jeu de vis	102
Urethane Pad PGV DPU 6555 Gleitvorrichtung PGV DPU 6555 Placa de DeslizamientoPGV DPU 6555 Jeu de Tapis en Polyuréthane	104
Starting crank Andrehkurbel Rückschlagsicher Manivela de arranque Manivelle de démarrage	106
Kit-mounting-Starting crank Anbausatz Andrehkurbel Juego-instalación-Manivela de arranque Jeu de montage-Manivelle de	108
Kit-retrofit belt guide Nachrüstatz Riemenberuhiger Juego de modificaciónguía de correa Lot de rattrapage	110

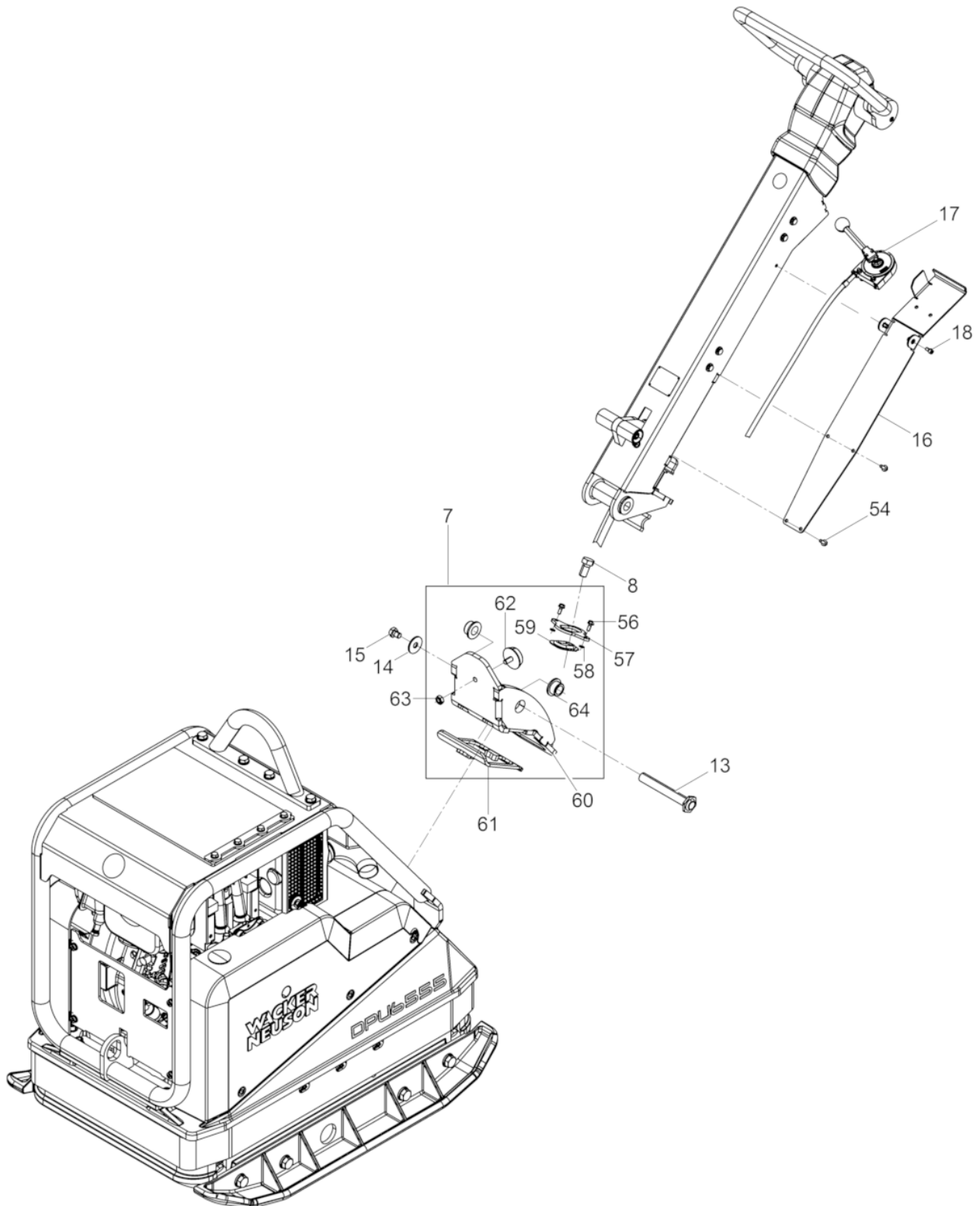

Ref. Pos.	Part No. Artikel Nr.	Qty. St.	Description Beschreibung	Descripción Description	Measurement/Abm.	Norm
					Torque/Drehm.	Sealant Schmierstoff
7	5100010938	1	Support cpl. Deichselbock kpl.	Caballote de apoyo cpl. Support cpl.		
8	0011523	4	Hexagonal head cap screw Sechskantschraube	Tornillo hexagonal Vis à tête hexagonale	M16 x 30 210Nm/155ft.lbs	DIN933
13	5100009632	1	Axle Achse	Eje Axe		
14	0010376	1	Flat washer Scheibe	Arandela Rondelle	A13	DIN9021
15	0014316	1	Hexagonal head cap screw Sechskantschraube	Tornillo hexagonal Vis à tête hexagonale	M12 x 16 86Nm/63ft.lbs	DIN933
16	5100009950	1	Cover Plate cpl. Deckblech kpl.	Cubierta de Chapa cpl. Coife cpl.		
17	5100010053	1	Operating lever cpl. Betätigung kpl.	Accionamiento cpl. Boîtier de com. avec câble		
18	0011553	2	Cheese head screw Zylinderschraube	Tornillo cilíndrico Vis à tête cylindrique	M6 x 16 10Nm/7ft.lbs	ISO4762
54	0204408	4	Screw Schraube	Tornillo Vis	DE M 6x 16	DIN7500
56	0204408	2	Screw Schraube	Tornillo Vis	DE M 6x 16	DIN7500
57	5100010505	1	Plate Blech	Chapa Tôle		
58	0010744	2	Washer Scheibe	Arandela Rondelle	6,4	DIN433
59	5100010504	1	Gasket Dichtung	Junta Joint		
60	5100003725	1	Support Deichselbock	Caballote de apoyo Support		
61	5100010503	1	Profiled joint Dichtungsprofil	Junta Joint d'étanchéité profilé		
62	5100005558	1	Shockmount Anschlagpuffer	Amortiguador Silentbloc	50 x 18 M10 x 20	
63	0010883	1	Hexagon nut Sechskantmutter	Tuerca hexagonal Écrou hexagonal	M10	DIN934
64	5100004367	2	Bush Buchse	Buje Boîte		

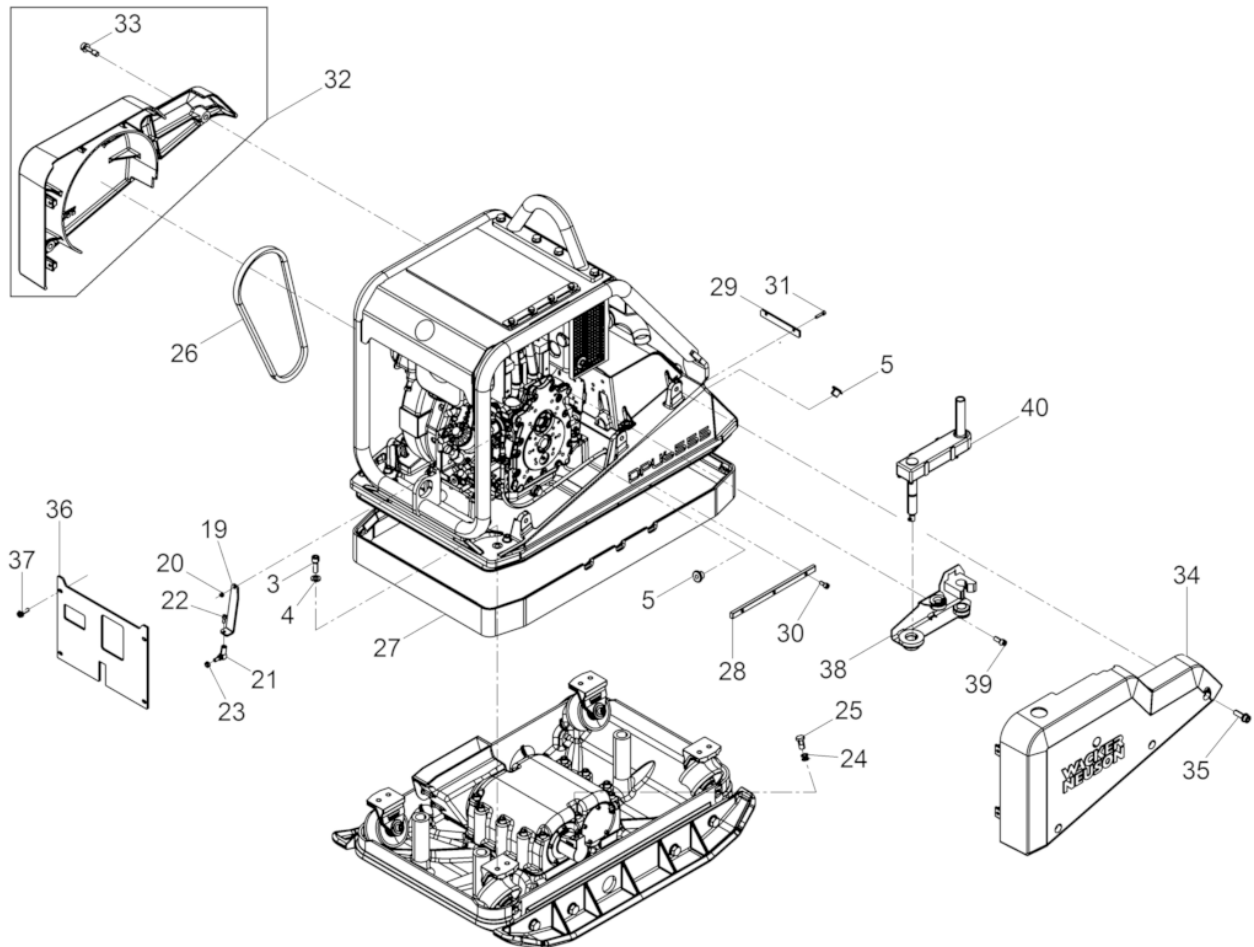

Ref. Pos.	Part No. Artikel Nr.	Qty. St.	Description Beschreibung	Descripción Description	Measurem./Abm.	Norm
					Torque/Drehm.	Sealant Schmierstoff
3	0011528	8	Cheese head screw Zylinderschraube	Tornillo cilíndrico Vis à tête cylindrique	M12 x 35 86Nm/63ft.lbs	ISO4762
4	0021465	8	Lock washer Sicherungsscheibe	Arandela de seguridad Rondelle d'arrêt	HS12	
5	0103880	2	Pipe guide Rohrdurchführung	Tubo de guía Passage de tuyau		
19	0103971	1	Lever Hebel	Palanca Levier		
20	0021679	1	Hexagon nut Sechskantmutter	Tuerca hexagonal Écrou hexagonal	M6	DIN980
21	0038403	1	Angular joint Winkelgelenk	Articulación angular Jointure engulaire	AS13	DIN71802
22	0011553	1	Cheese head screw Zylinderschraube	Tornillo cilíndrico Vis à tête cylindrique	M6 x 16 10Nm/7ft.lbs	ISO4762
23	0010882	1	Hexagon nut Sechskantmutter	Tuerca hexagonal Écrou hexagonal	M8	ISO4032
24	0012624	2	Gasket Dichtring	Anillo de junta Bague d'étanchéité	A14 x 18	DIN7603
25	0043201	1	Banjo bolt Hohlschraube	Perno hueco Boulon creux à filet femelle	10-3	DIN7643
26	0094072	1	V-belt Keilriemen	Correa en V Courroie	17 x 1080	
27	5100009633	1	Apron Schürze	Protección Tablier		
28	0097110	2	Bar Leiste	Listón Listeau		
29	5100009635	1	Bar Leiste	Listón Listeau		
30	0103962	6	Cheese head screw Zylinderschraube	Tornillo cilíndrico Vis à tête cylindrique	M8 x 18 25Nm/18ft.lbs	ISO4762
31	0011550	2	Cheese head screw Zylinderschraube	Tornillo cilíndrico Vis à tête cylindrique	M6 x 25 10Nm/7ft.lbs	ISO4762
32	5100002778	1	Belt guard Riemenschutz	Protección de la polea Protection de courroie		
33	0220202	3	Screw Dünnschaftschraube	Tornillo Vis	M12x 40	
34	0220365	1	Protective hood Schutzhaube	Cubierta de protección Capot de protection		
35	0220325	3	Screw Sicherungsschraube	Tornillo Vis	M 12x 35	
36	0220190	1	Guard plate Schutzblech	Chapa protectora Tôle de protection		
37	0129420	4	Socket head cap screw Zylindersicherungsschraube	Tornillo de seguridad Poignée supplémentaire		
38	5100003970	1	Crank holder cpl. Kurbelhalter kpl.	Porta-manivela cpl. Support manivelle cpl.		
39	0011535	2	Cheese head screw Zylinderschraube	Tornillo cilíndrico Vis à tête cylindrique	M10 x 25 49Nm/36ft.lbs	ISO4762
40	0095187	1	Starting crank Andrehkurbel rückschlagsicher	Manivela de arranque Manivelle de démarrage		

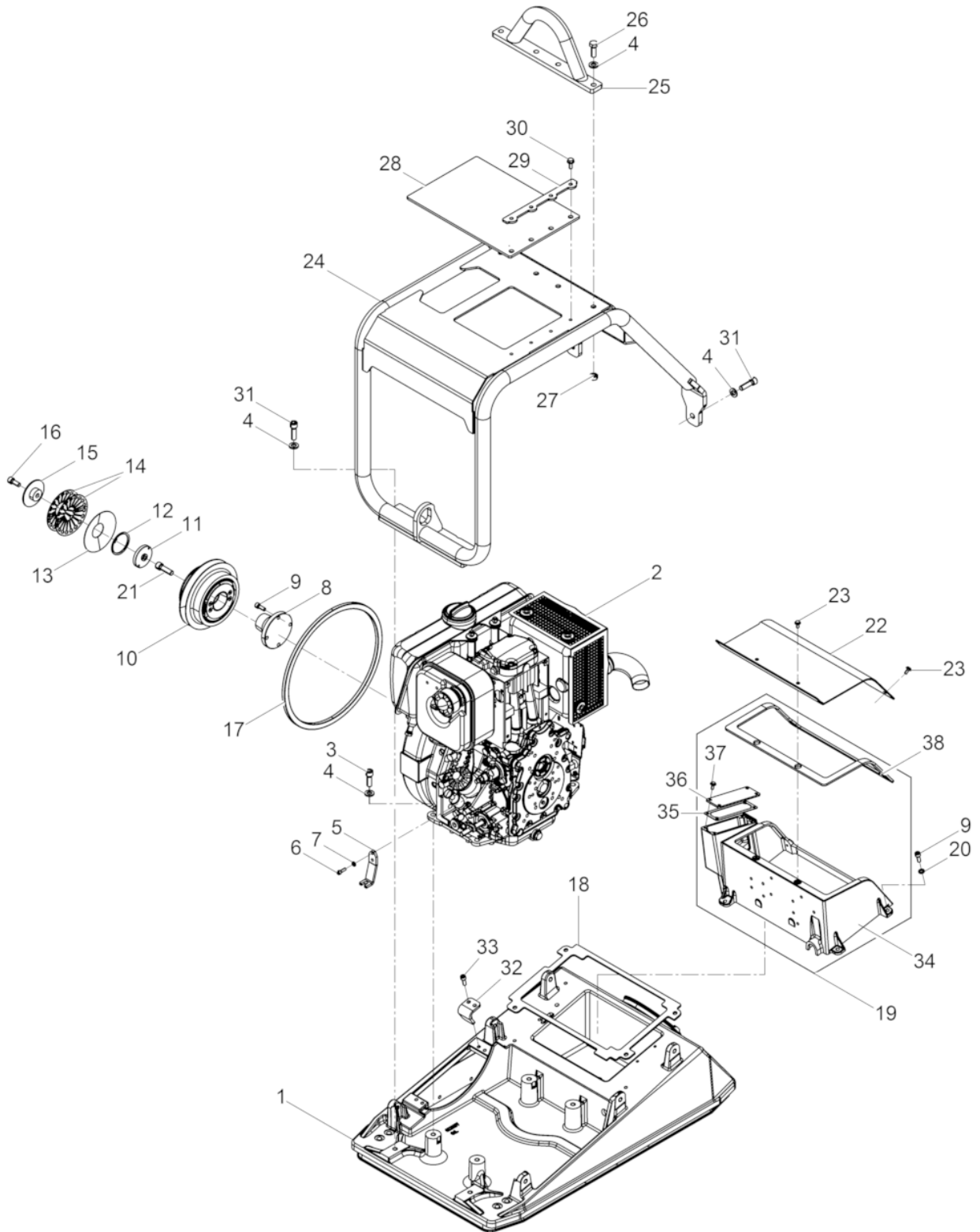

Ref. Pos.	Part No. Artikel Nr.	Qty. St.	Description Beschreibung	Descripción Description	Measurem./Abm.	Norm
					Torque/Drehm.	Sealant Schmierstoff
1	510003737	1	Upper Mass Obermasse	Masa Superior Masse Superieure		
2	0215019	1	Diesel engine Dieselmotor	Motor diesel Moteur diesel		
3	0011528	4	Cheese head screw Zylinderschraube	Tornillo cilíndrico Vis à tête cylindrique	M12 x 35 86Nm/63ft.lbs	ISO4762
4	0021465	12	Lock washer Sicherungsscheibe	Arandela de seguridad Rondelle d'arrêt	HS12	
5	0103893	1	Angle Winkel	Ángulo Coude		
6	0011551	2	Cheese head screw Zylinderschraube	Tornillo cilíndrico Vis à tête cylindrique	M6 x 20 10Nm/7ft.lbs	ISO4762
7	0010624	2	Flat washer Scheibe	Arandela Rondelle	6	ISO7090
8	0069900	1	Flange Flansch	Brida Bride		
9	0012629	8	Cheese head screw Zylinderschraube	Tornillo cilíndrico Vis à tête cylindrique	M8 x 22 25Nm/18ft.lbs	ISO4762
10	0102208	1	Coupling cpl. Kupplung kpl.	Embrague cpl. Embrayage cpl.		
11	0058546	1	Disc Scheibe	Disco Disque		
12	0021147	1	Retaining ring Sicherungsring	Anillo de retención Bague d'arrêt	60 x 2	DIN472
13	0048273	1	Seal Dichtung	Junta Joint		
14	0048374	1	Cup spring Tellerfeder	Resorte de platillo Ressort belleville		
15	0058547	2	Button Pilz	Fungiforme Butée		
16	0011534	1	Cheese head screw Zylinderschraube	Tornillo cilíndrico Vis à tête cylindrique	M10 x 30 49Nm/36ft.lbs	ISO4762
17	0048539	1	Seal Dichtung	Junta Joint		
18	0220183	1	Gasket Dichtung	Junta de estanqueidad Garniture		
19	0220345	1	Battery protection cpl. Batterieschutz kpl.	Protección de batería cpl. Protection de batterie cpl.		
20	0010742	4	Washer Scheibe	Arandela Rondelle	8,4	DIN433
21	5100010091	1	Cheese head screw Zylinderschraube	Tornillo cilíndrico Vis à tête cylindrique	M12x 40	
22	5100015058	1	Plate Blech	Chapa Tôle		
23	0210194	4	corrugated-head screw Sicherungsschraube	Tornillo Vis	M 6x 14	
24	0220339	1	Protective frame Schutzrahmen	Armazón de protección Cadre protection		
25	0099055	1	Hook Öse	Punto de izaje Crochet		

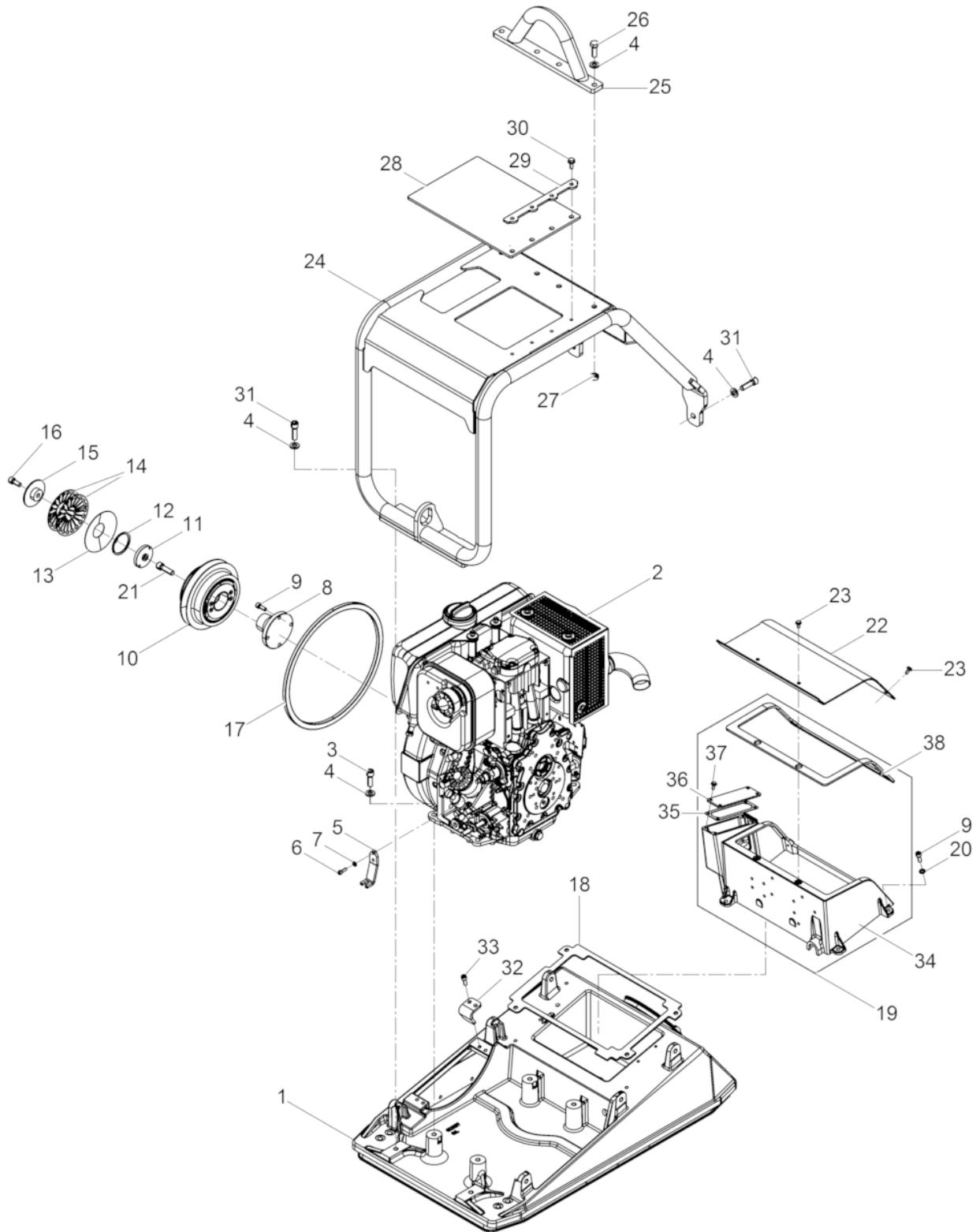

Ref. Pos.	Part No. Artikel Nr.	Qty. St.	Description Beschreibung	Descripción Description	Measurem./Abm.	Norm
					Torque/Drehm.	Sealant Schmierstoff
26	0011422	4	Hexagonal head cap screw Sechskantschraube	Tornillo hexagonal Vis à tête hexagonale	M12 x 35 86Nm/63ft.lbs	DIN933
27	0010884	4	Hexagon nut Sechskantmutter	Tuerca hexagonal Écrou hexagonal	M12	DIN934
28	0099535	1	Plate Platte	Placa Plaque		
29	0099047	1	Bar Leiste	Listón Listeau		
30	0105944	4	Screw Schraube	Tornillo Vis	DE M8 x 20	DIN7500
31	0201094	4	Cheese head screw Zylinderschraube	Tornillo cilíndrico Vis à tête cylindrique	M12 x 50 120Nm/89ft.lbs	ISO4762
32	0220334	2	Angle Winkel	Angulo Angle		
33	0129420	2	Socket head cap screw Zylindersicherungsschraube	Tornillo de seguridad Poignée supplémentaire		
34	5100011288	1	Battery protection Batterieschutz	Protección de batería Protection de batterie		
35	0216678	1	Gasket Dichtung	Junta de estanqueidad Garniture		
36	0220337	1	Plate Blech	Chapa Tôle		
37	0210194	4	corrugated-head screw Sicherungsschraube	Tornillo Vis	M 6x 14	
38	0220173	1	Gasket Dichtung	Junta de estanqueidad Garniture		

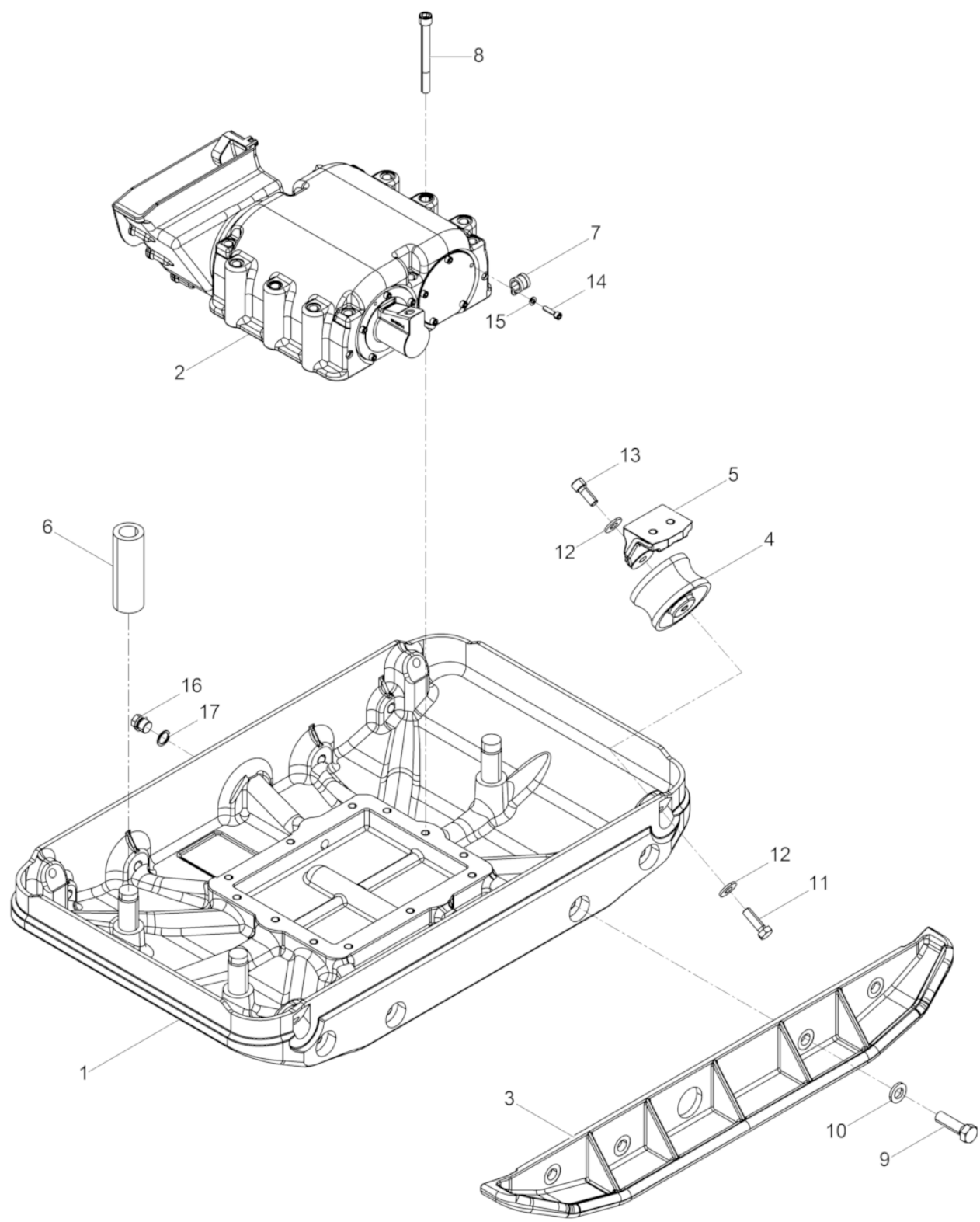

Ref. Pos.	Part No. Artikel Nr.	Qty. St.	Description Beschreibung	Descripción Description	Measurem./Abm.	Norm
					Torque/Drehm.	Sealant Schmierstoff
1	0102083	1	Baseplate Untermasse	Masa inferior Masse inferieure		
2	0220084	1	Exciter cpl. Erreger kpl.	Excitador cpl. Excitateur cpl.		
3	0044442	2	Extension plate Anbauplatte	Placa de extensión Elargisseur	8 cm	
4	2004814	4	Shockmount Gimetall-Kerblager mit Bund	Amortiguador Silentbloc	100 x 58	
5	0102105	4	Support Pufferbock	Soporte tope Support d'amortisseur		
6	0034442	3	Bushing Dämpfungsbuchse	Buje Douille		
7	0017123	1	Pipe clamp Rohrschelle	Abrazadera Collier pour tuyau		
8	0094518	12	Cheese head screw Zylinderschraube	Tornillo cilíndrico Vis à tête cylindrique	M12 x 120 120Nm/89ft.lbs	ISO4762
9	0039191	8	Hexagonal head cap screw Sechskantschraube	Tornillo hexagonal Vis à tête hexagonale	M16 x 1,5 x 55 210Nm/155ft.lbs	DIN961
10	0021988	8	Lock washer Sicherungsscheibe	Arandela de seguridad Rondelle d'arrêt	HS16	
11	0011421	4	Hexagonal head cap screw Sechskantschraube	Tornillo hexagonal Vis à tête hexagonale	M12 x 40 86Nm/63ft.lbs	DIN933
12	0031565	8	Lockwasher Spannscheibe	Arandela elástica Rondelle de ressort	12	DIN6796
13	0011529	4	Cheese head screw Zylinderschraube	Tornillo cilíndrico Vis à tête cylindrique	M12 x 30 86Nm/63ft.lbs	ISO4762
14	0011550	1	Cheese head screw Zylinderschraube	Tornillo cilíndrico Vis à tête cylindrique	M6 x 25 10Nm/7ft.lbs	ISO4762
15	0010624	1	Flat washer Scheibe	Arandela Rondelle	6	ISO7090
16	0068222	1	Plug (threaded) Verschlußschraube	Tapón roscado Bouchon	M18 x 1,5	DIN910
17	0019156	1	Gasket Dichtring	Anillo de junta Bague d'étanchéité	A18 x 24	DIN7603
19	0219702	1	Flange Flansch	Brida Bride		

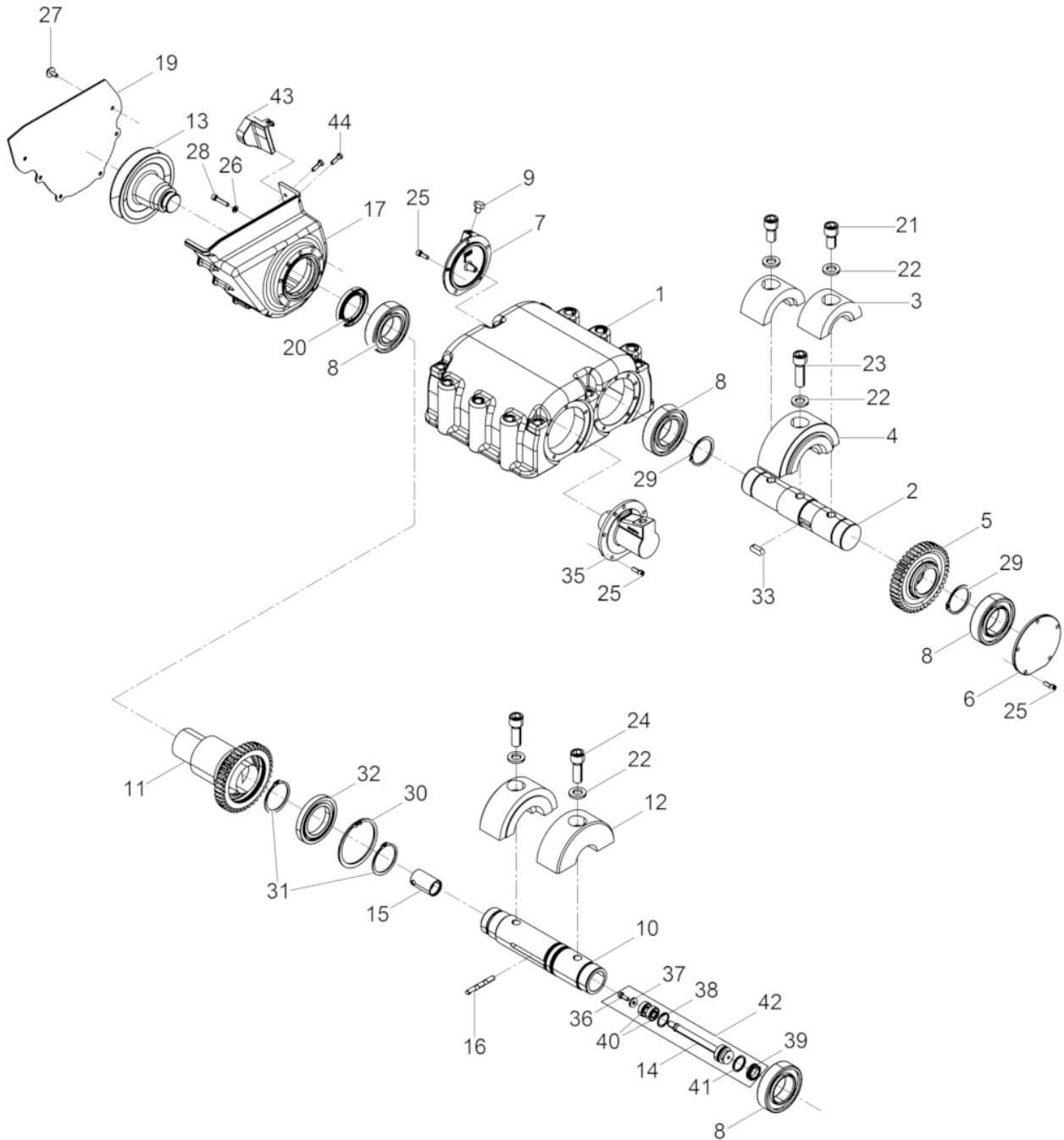

Ref. Pos.	Part No. Artikel Nr.	Qty. St.	Description Beschreibung	Descripción Description	Measurement./Abm.	Norm
					Torque/Drehm.	Sealant Schmierstoff
1	0099059	1	Exciter housing Erregergehäuse	Carcasa del excitador Carter excitateur		
2	0220059	1	Shaft Welle	Árbol Arbre		
3	0220082	2	Eccentric weight Unwucht	Masa excéntrica Balourd		
4	0220110	1	Eccentric weight Unwucht	Masa excéntrica Balourd		
5	0039116	1	Gear wheel Zahnrad	Engranaje Roue dentée		
6	0039110	1	Cover Deckel	Tapa Couvercle		
7	0102144	1	Vent cover Belüftungsdeckel	Tapa de ventilación Couvercle d'aération		
8	0103469	4	Cylindrical roller bearing Zylinderrollenlager	Rodamiento cilíndricos Roulement à rouleaux		
9	1103030	1	Vent screw Entlüftungsschraube	Tornillo de purga Vis d'évacuation d'air		
10	0220077	1	Shaft Welle	Árbol Arbre		
11	0220053	1	Adjusting sleeve Verstellhülse	Husillo de regulación Douille de réglage		
12	0220083	2	Eccentric weight Unwucht	Masa excéntrica Balourd		
13	0129859	1	V-belt pulley Keilriemenscheibe	Polea en V Poulie à courroie		
14	0220079	1	Bolt Bolzen	Perno Boulon		
15	0220106	1	Indexing bolt Schaltbolzen	Perno fijador Boulon		
16	0043382	1	Tripping pin Schaltstift	Espiga de mando Broche de manoeuvre		
17	0201522	1	Protective box Schutzkasten	Caja de protección Boitier de protection		
19	0104124	1	Plate Blech	Chapa Tôle		
20	0048854	1	Rotary shaft seal Wellendichtring	Anillo de retén radial Bague d'étanchéité	48 x 72 x 7,4	
21	0044634	2	Cheese head screw Zylinderschraube	Tornillo cilíndrico Vis à tête cylindrique	M16 x 30 295Nm/218ft.lbs	ISO4762
22	0021988	5	Lock washer Sicherungsscheibe	Arandela de seguridad Rondelle d'arrêt	HS16	
23	0043812	1	Cheese head screw Zylinderschraube	Tornillo cilíndrico Vis à tête cylindrique	M16 x 50 295Nm/218ft.lbs	ISO4762
24	0126300	2	Cheese head screw Zylinderschraube	Tornillo cilíndrico Vis à tête cylindrique	M16 x 45 295Nm/218ft.lbs	ISO4762
25	0011552	14	Cheese head screw Zylinderschraube	Tornillo cilíndrico Vis à tête cylindrique	M6 x 18 10Nm/7ft.lbs	ISO4762
26	0010624	9	Flat washer Scheibe	Arandela Rondelle	6	ISO7090

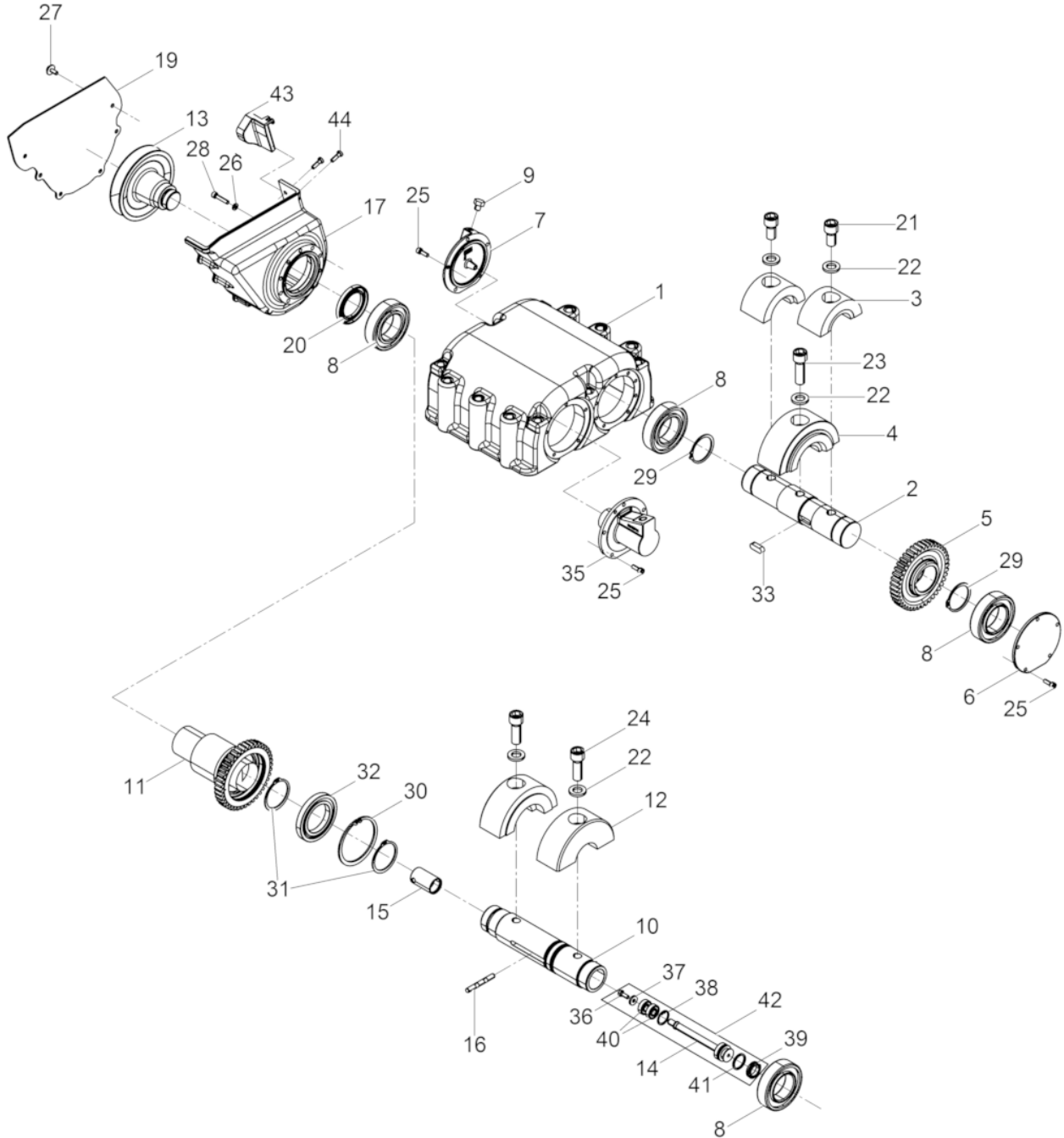

Ref. Pos.	Part No. Artikel Nr.	Qty. St.	Description Beschreibung	Descripción Description	Measurement./Abm.	Norm
					Torque/Drehm.	Sealant Schmierstoff
27	5100009501	6	Screw Kombi-Schraube	Tornillo Vis	M 6x 16 10Nm/7ft.lbs	
28	0011549	9	Cheese head screw Zylinderschraube	Tornillo cilíndrico Vis à tête cylindrique	M6 x 30 10Nm/7ft.lbs	ISO4762
29	2006113	2	Retaining ring Sicherungsring	Anillo de retención Bague d'arrêt	50 x 2	DIN471
30	2007057	1	Retaining ring Sicherungsring	Anillo de retención Bague d'arrêt	90 x 3	DIN472
31	2004822	2	Retaining ring Sicherungsring	Anillo de retención Bague d'arrêt	55 x 2	DIN471
32	0220133	1	Grooved ball bearing Rillenkugellager	Rodamiento a bolas Roulement rainuré à billes		DIN625
33	2001399	1	Fitting key Passfeder	Chaveta Clavette	A10 x 8 x 28	DIN6885
35	0048604	1	Cylinder cover Zylinderdeckel	Tapa del cilindro Couvercle de cylindre		
36	0124717	1	Washer Scheibe	Arandela Rondelle	6,4	DIN6340
37	0014663	1	Hexagonal head cap screw Sechskantschraube	Tornillo hexagonal Vis à tête hexagonale	M6 x 16 10Nm/7ft.lbs	DIN933
38	0220384	1	Retaining ring Sicherungsring	Anillo de retención Bague d'arrêt	26x 1,20	DIN472
39	0043203	1	Lip seal ring Gummilippenring	Reten labial de goma Bague en caoutchouc	30 x 20 x 6	
40	0220383	2	Grooved ball bearing Rillenkugellager	Rodamiento a bolas Roulement rainuré à billes		DIN625
41	2006991	1	O-ring O-Ring	Anillo-O Bague-O	24 x 3	
42	0220081	1	Bolt cpl. Bolzen kpl.	Perno cpl. Boulon cpl.		
43	5100003656	1	belt guide Riemenberuhiger	guía de correa guide-courroie		
44	5100013871	2	Oval head screw Linsenkopfschraube	Tornillo gota de sebo Vis noyée lentiforme	6 x 20	

Center Pole cpl.
Deichsel kpl.
Barra de mando cpl.
Timon cpl.

DPU 6555Hs

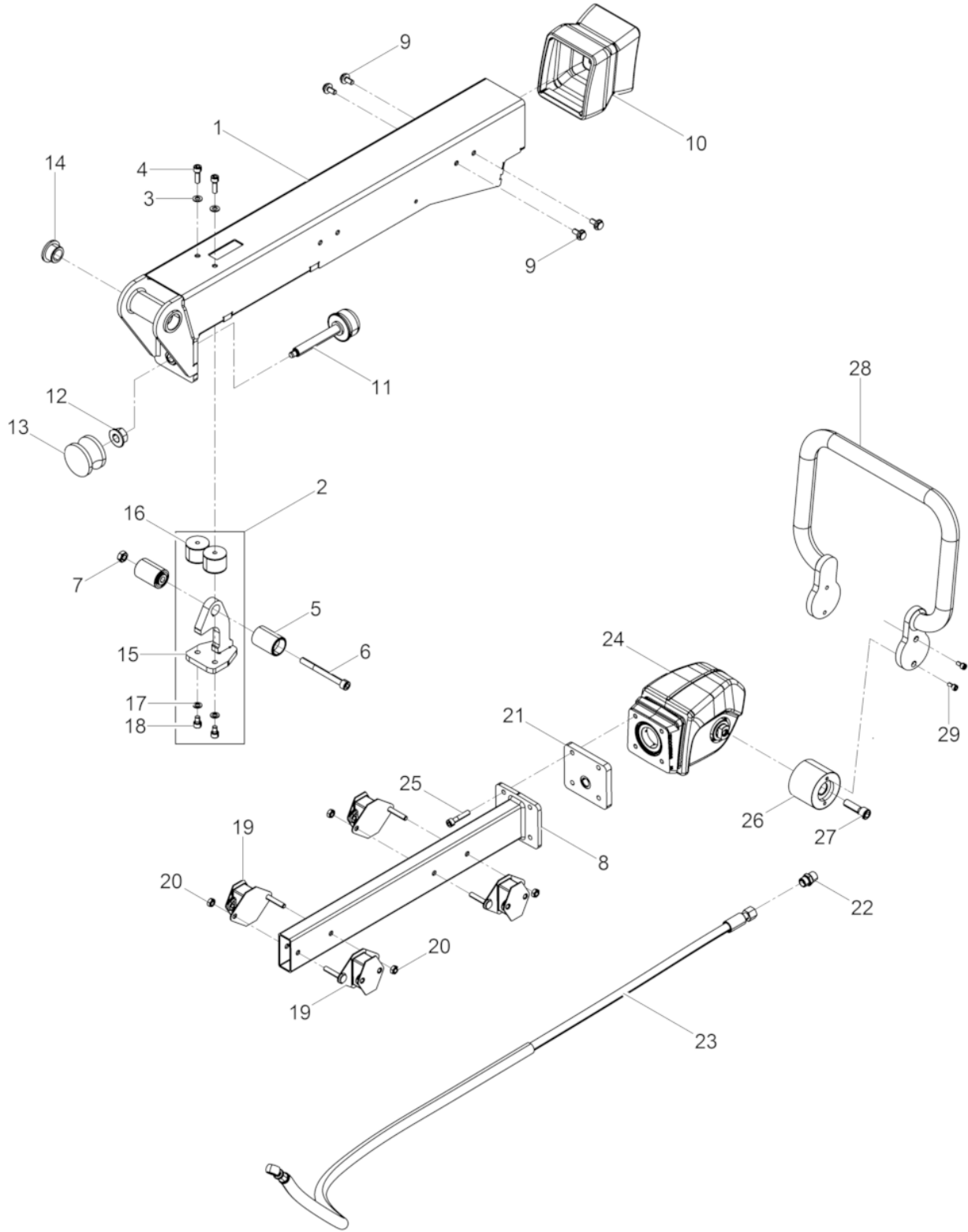

Ref. Pos.	Part No. Artikel Nr.	Qty. St.	Description Beschreibung	Descripción Description	Measurem./Abm.	Norm
					Torque/Drehm.	Sealant Schmierstoff
1	5100009952	1	Center Pole tube Deichselrohr	Barra de mando tubo Timon tube		
2	5100005543	1	Lock Arretierung	Dispositivo de retención Dispositif d'arrêt		
3	0010622	2	Flat washer Scheibe	Arandela Rondelle	8	ISO7090
4	0013574	2	Cheese head screw Zylinderschraube	Tornillo cilíndrico Vis à tête cylindrique	M8 x 12 25Nm/18ft.lbs	ISO4762
5	5100002007	2	Retaining Handle Arretierungsgriff	Empuñadura de Retención Poignée D'Arrêt		
6	0037090	1	Cheese head screw Zylinderschraube	Tornillo cilíndrico Vis à tête cylindrique	M10 x 100 49Nm/36ft.lbs	ISO4762
7	0010883	1	Hexagon nut Sechskantmutter	Tuerca hexagonal Écrou hexagonal	M10	DIN934
8	5100005106	1	square tube cpl. Vierkantrohr kpl.	tubo cuadrado cpl. Tube carré cpl.		
9	0211795	8	corrugated-head screw Sicherungsschraube	Tornillo Vis	M 8 x 16	
10	5100005538	1	Bellows Faltenbalg	Fuelle acordeón Soufflet		
11	0043928	1	Threaded spindle cpl. Gewindespindel kpl.	Husillo roscado cpl. Tige fileté cpl.		
12	0202866	1	Locknut Sechskantmutter	Contratuerca Contre-écrou	M16	EN1661
13	0043233	1	Shockmount Gummi-Metall-Kerbpuffer	Tope caucho-metal Tampon métallique oscillant	60 x 40	
14	5100004367	2	Bush Buchse	Buje Boîte		
15	5100005541	1	Lock Arretierung	Dispositivo de retención Dispositif d'arrêt		
16	0129818	2	Shockmount Gummi-Metall-Puffer	Tope caucho-metal Tampon métallique oscillant		
17	0010742	2	Washer Scheibe	Arandela Rondelle	8,4	DIN433
18	0011543	2	Cheese head screw Zylinderschraube	Tornillo cilíndrico Vis à tête cylindrique	M8 x 20 24Nm/18ft.lbs	ISO4762
19	5100010497	4	Shockmount Gummipuffer	Tope caucho-metal Tampon oscillant		
20	0010882	4	Hexagon nut Sechskantmutter	Tuerca hexagonal Écrou hexagonal	M8	ISO4032
21	5100005526	1	Flange Flansch	Brida Bride		
22	0069225	1	Screwed socket Einschraubstutzen	Empalme roscado Manchon visse	R3/8in	
23	5100005553	1	Hose pipe Schlauchleitung	Conducto flexible Conduite flexible		
24	5100027083	1	Center Pole Head cpl. Deichselkopf kpl.	Cabezal de mando cpl. Tête de timon cpl.		
25	0011539	4	Cheese head screw Zylinderschraube	Tornillo cilíndrico Vis à tête cylindrique	M8 x 40 25Nm/18ft.lbs	ISO4762

Center Pole cpl.
Deichsel kpl.
Barra de mando cpl.
Timon cpl.

DPU 6555Hs

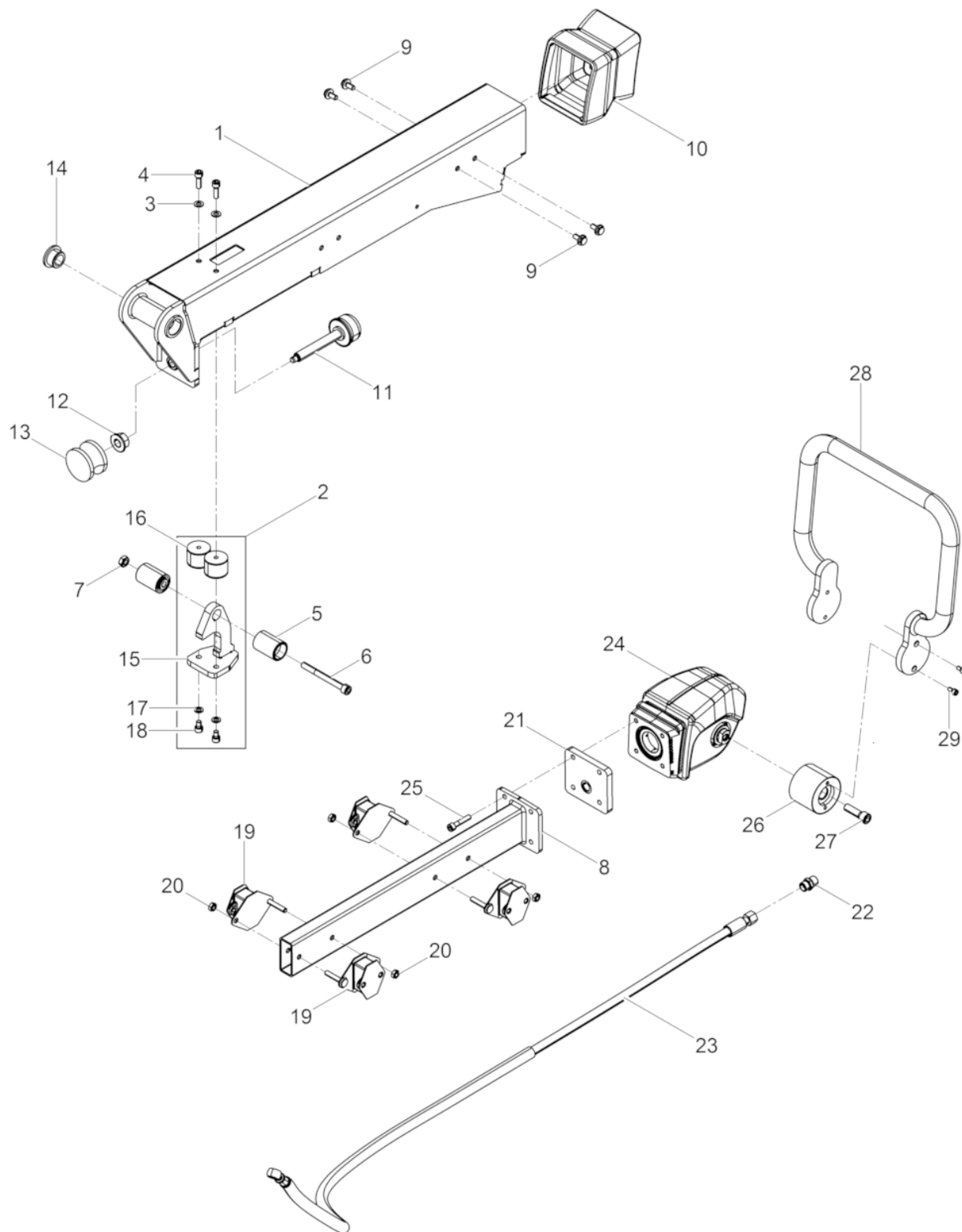

Ref. Pos.	Part No. Artikel Nr.	Qty. St.	Description Beschreibung	Descripción Description	Measurement./Abm.	Norm
					Torque/Drehm.	Sealant Schmierstoff
26	0215035	2	Shockmount Gummi-Metall-Puffer	Tope caucho-metal Tampon metallique oscillant		
27	0011527	2	Cheese head screw Zylinderschraube	Tornillo cilíndrico Vis à tête cylindrique	M12 x 40 86Nm/63ft.lbs	ISO4762
28	5100005124	1	Clamp Bügel	Abrazadera Attache		
29	0011554	4	Cheese head screw Zylinderschraube	Tornillo cilíndrico Vis à tête cylindrique	M6 x 12 10Nm/7ft.lbs	ISO4762

Center Pole Head cpl.
Deichselkopf kpl.
Cabezal de mando cpl.
Tête de timon cpl.

DPU 6555Hs

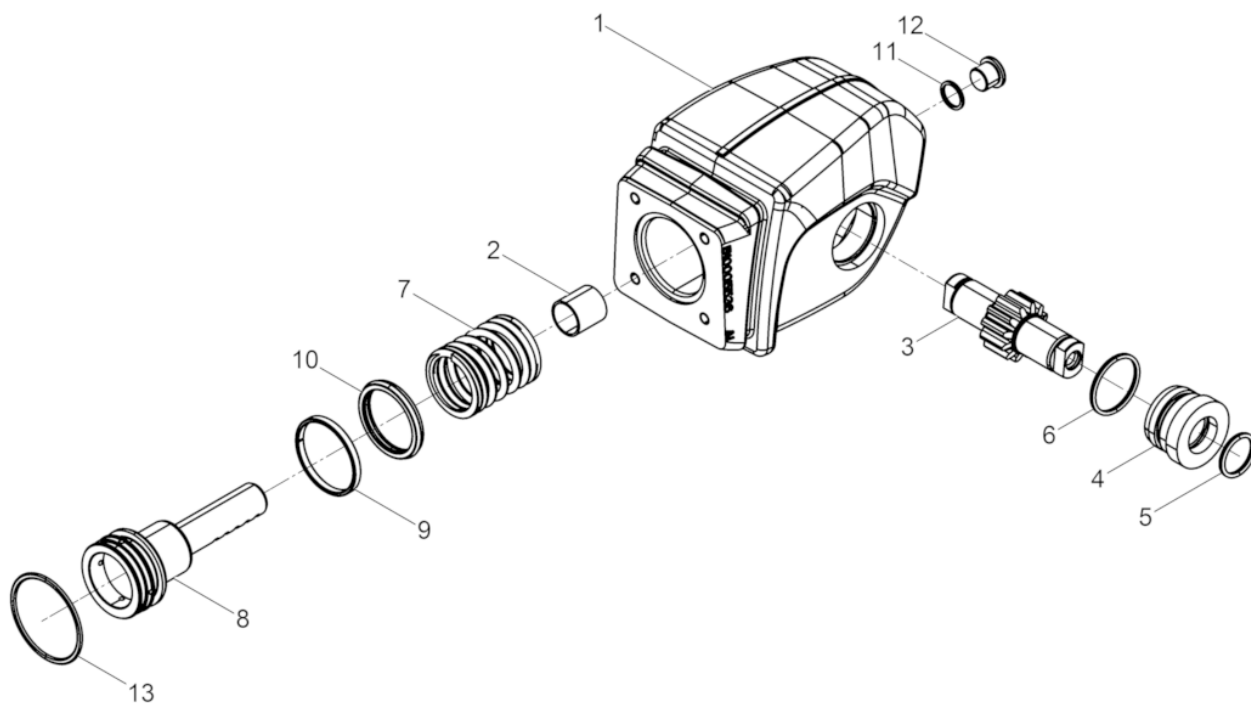

Ref. Pos.	Part No. Artikel Nr.	Qty. St.	Description Beschreibung	Descripción Description	Measurement/Abm.	Norm
					Torque/Drehm.	Sealant Schmierstoff
1	5100005537	1	Center pole head Deichselkopf	Cabezal de barra Tête de timon		
2	0126164	1	Slide bush Gleitbuchse	Buje deslizante Bôte de glissement		
3	0069726	1	Long face pinion Zahnradwelle	Eje de rueda dentada Arbre formant pignon		
4	0125926	2	Spacer Distanzstück	Pieza distanciadora Pièce d'écartement		
5	0018194	2	O-ring O-Ring	Anillo-O Bague-O	26 x 3	
6	0068752	2	O-ring O-Ring	Anillo-O Bague-O	38 x 3	
7	5100005559	1	Compression spring Druckfeder	Resorte de compresión Ressort de pression		
8	5100005138	1	Control piston Steuerkolben	Pistón de mando Piston de commande		
9	5100005532	1	Guide Ring Führungsring	Anillo Guía Bague de Guidage	KB 55x50x5,5 HG517	
10	5100005533	1	Gasket Dichtung	Junta Joint		
11	0012082	1	Gasket Dichtring	Anillo de junta Bague d'étanchéité	A16 x 20	DIN7603
12	0011050	1	Plug (threaded) Verschlußschraube	Tapón roscado Bouchon	M16 x 1,5	DIN908
13	0039235	1	O-ring O-Ring	Anillo-O Bague-O	58 x 3	

Coupling cpl.
Kupplung kpl.
Embrague cpl.
Embrayage cpl.

DPU 6555Hs

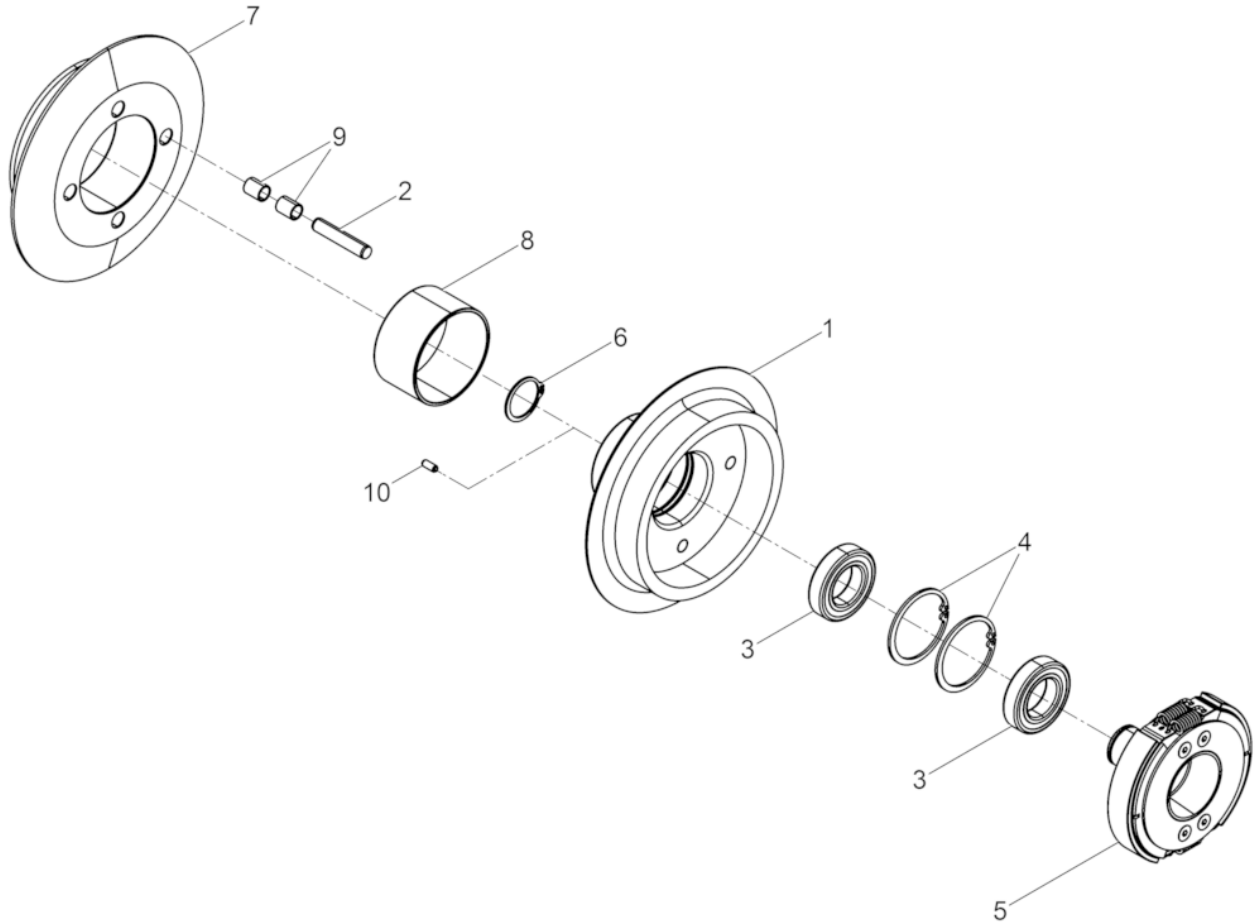

Ref. Pos.	Part No. Artikel Nr.	Qty. St.	Description Beschreibung	Descripción Description	Measurement./Abm.	Norm
					Torque/Drehm.	Sealant Schmierstoff
1	0058541	1	Clutch drum Kupplungsglocke	Campana del embrague Cloche de rentrée	49Nm/36ft.lbs	
2	0058539	4	Pin Stift	Espiga Goupille		
3	0039999	2	Grooved ball bearing Rillenkugellager	Rodamiento a bolas Roulement rainuré à billes		
4	2003826	2	Retaining ring Sicherungsring	Anillo de retención Bague d'arrêt	55 x 2	DIN472
5	0201992	1	Centrifugal Clutch Fliehkraftkupplung	Embrague Embrayage		
6	2001815	1	Retaining ring Sicherungsring	Anillo de retención Bague d'arrêt	30 x 1,5	DIN471
7	0058540	1	V-belt pulley Keilriemenscheibe	Polea en V Poulie à courroie		
8	0058536	1	Bushing Buchse	Buje Boîte	70 ID	
9	0058551	8	Bush Buchse	Casquillo Boîte	10 ID	
10	0013591	2	Spring pin Spannstift	Pasador de sujeción Goupille élastique	5 x 12	DIN1481

Centrifugal Clutch cpl.
Fliehkraftkupplung kpl.
Embrague centrifugo cpl.
Embrayage centrifuge cpl.

DPU 6555Hs

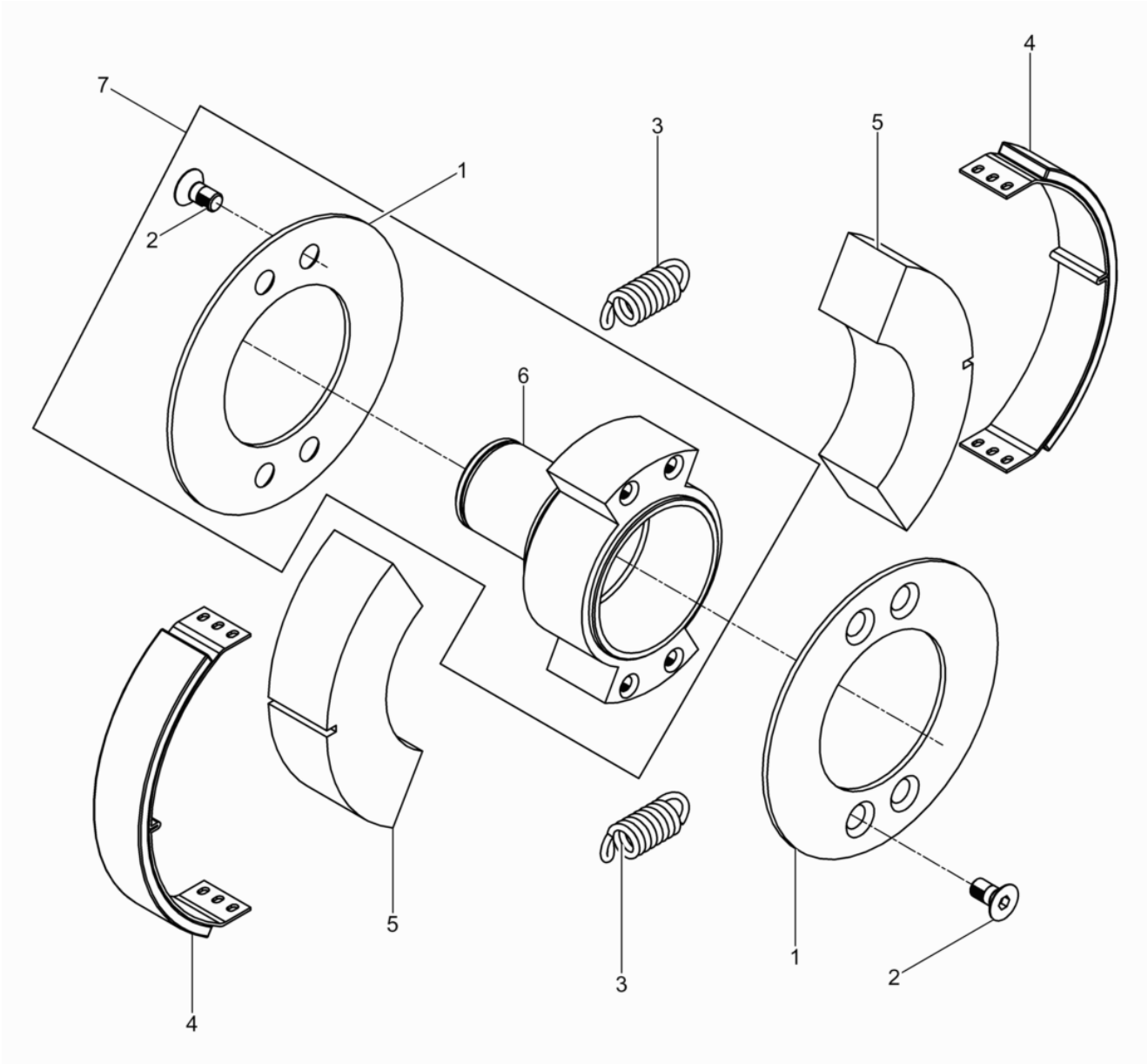

Ref. Pos.	Part No. Artikel Nr.	Qty. St.	Description Beschreibung	Descripción Description	Measurement./Abm.	Norm.
					Torque/Drehm.	Sealant Schmierstoff
1	0201994	2	Fixing disc Fixierscheibe	Arandela de retención Rondelle de fixation		
2	0024338	8	Countersunk screw Senkschraube	Tornillo avellanado Vis noyée	M6 x 10	DIN963
3	0045979	4	Tension spring Zugfeder	Resorte de tracción Ressort de traction		
4	2006075	2	Lining Belagträger	Zapata Garniture d'embrayage		
5	0049506	2	Centrifugal weight Fliehk Gewicht	Peso centrífugo Poids centrifuge		
6	0201993	1	Hub Nabe	Cubo Moyeu		
7	0203003	1	Hub kit Nabensatz	Juego de cubo Jeu de moyeu		

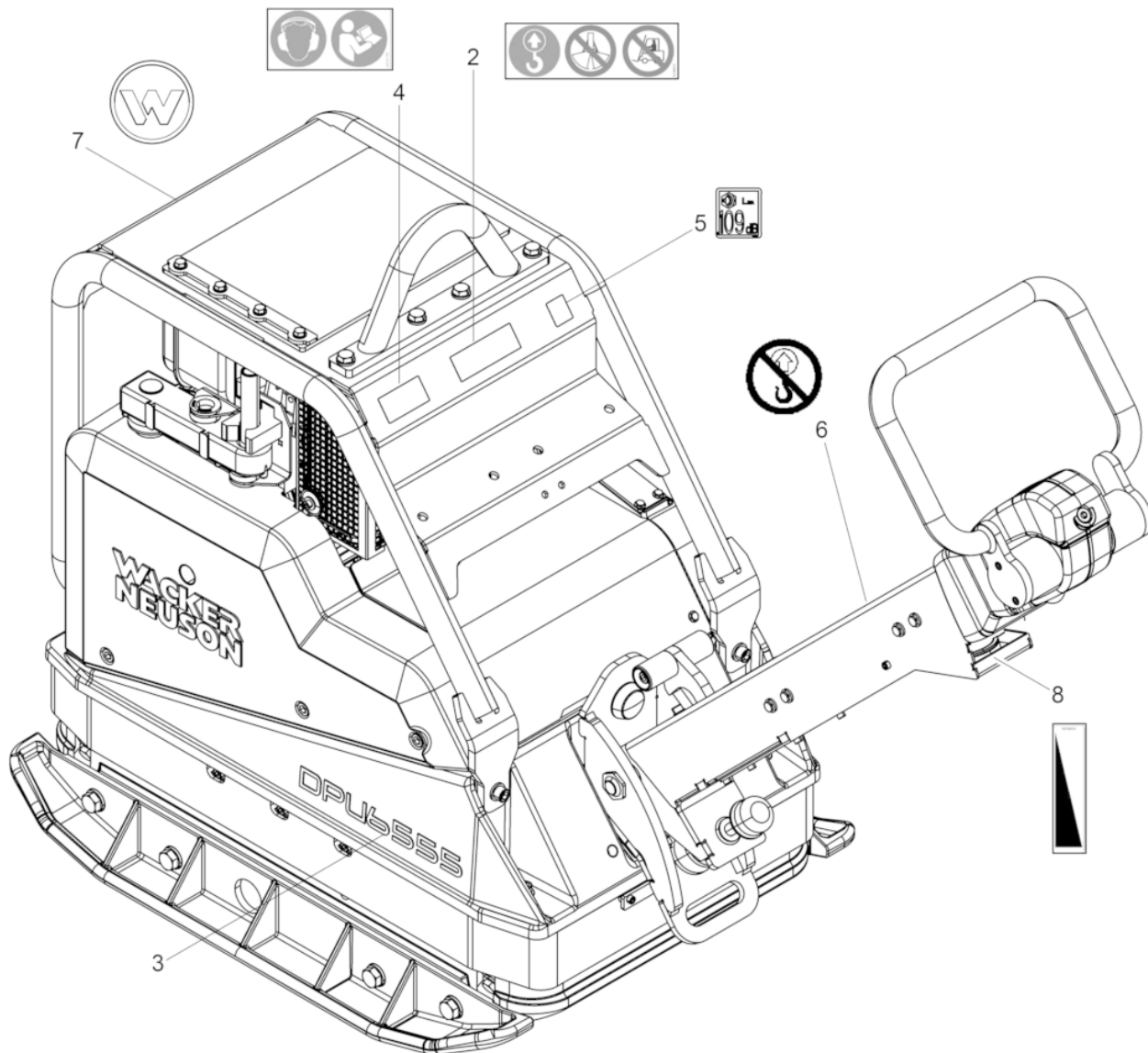

Ref. Pos.	Part No. Artikel Nr.	Qty. St.	Description Beschreibung	Descripción Description	Measurem./Abm.	Norm
					Torque/Drehm.	Sealant Schmierstoff
2	0216633	1	Instruction Label Aufkleber-Hinweis	Calcomanía-Indicación Autocollant avec Indication	100 x 35	
3	0220386	2	Type Label Aufkleber-Typ	Tipo etiqueta autoadhesiva Autocollant de type		
4	0219175	1	Labels Aufkleber	Calcomanias Autocollants		
5	0064925	1	Decal-Sound Power Level Aufkleber-Schallleistungspegel	Etiqueta autoadhesiva-nivel de potencia acúeética Autocollante-niveau sonore		
6	0220000	1	Instruction Label Aufkleber-Warnhinweis	Calcomanía-Indicación Autocollant avec Indication	ø50	
7	0222085	1	Label Symbol Aufkleber Symbol	Calcomania Símbolo Autocollant Symbole		
8	0219259	1	Labels Aufkleber	Calcomanias Autocollants		

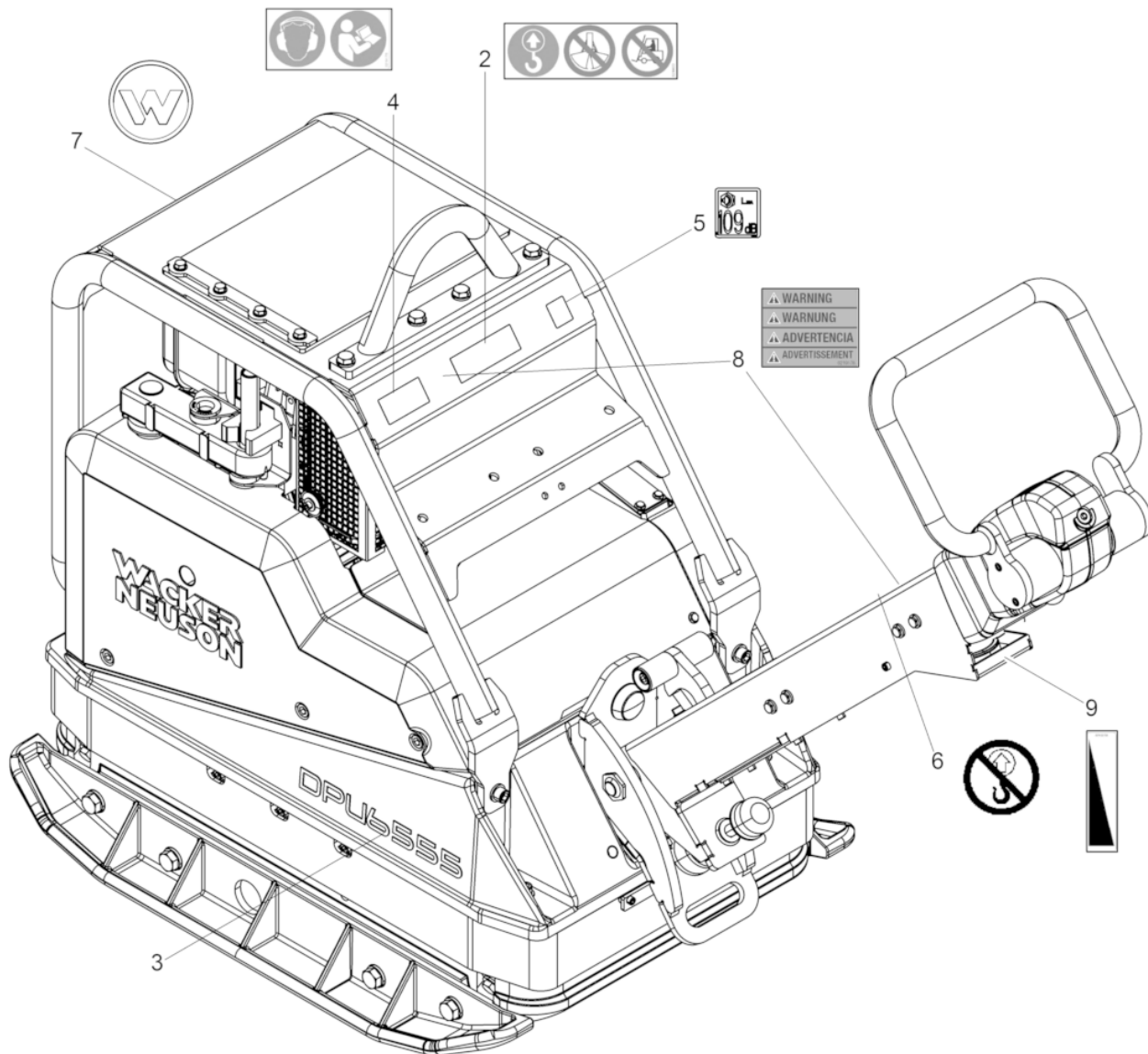

Ref. Pos.	Part No. Artikel Nr.	Qty. St.	Description Beschreibung	Descripción Description	Measurem./Abm.	Norm
					Torque/Drehm.	Sealant Schmierstoff
2	0216633	1	Instruction Label Aufkleber-Hinweis	Calcomanía-Indicación Autocollant avec Indication	100 x 35	
3	0220386	2	Type Label Aufkleber-Typ	Tipo etiqueta autoadhesiva Autocollant de type		
4	0219175	1	Labels Aufkleber	Calcomanias Autocollants		
5	0064925	1	Decal-Sound Power Level Aufkleber-Schallleistungspegel	Etiqueta autoadhesiva-nivel de potencia acúeética Autocollante-niveau sonore		
6	0220000	1	Instruction Label Aufkleber-Warnhinweis	Calcomanía-Indicación Autocollant avec Indication	ø50	
7	0222085	1	Label Symbol Aufkleber Symbol	Calcomanía Símbolo Autocollant Symbole		
8	0219176	2	Labels Aufkleber	Calcomanias Autocollants		
9	0219259	1	Labels Aufkleber	Calcomanias Autocollants		



**WACKER
NEUSON**

**Engine
Motor
Motor
Moteur**

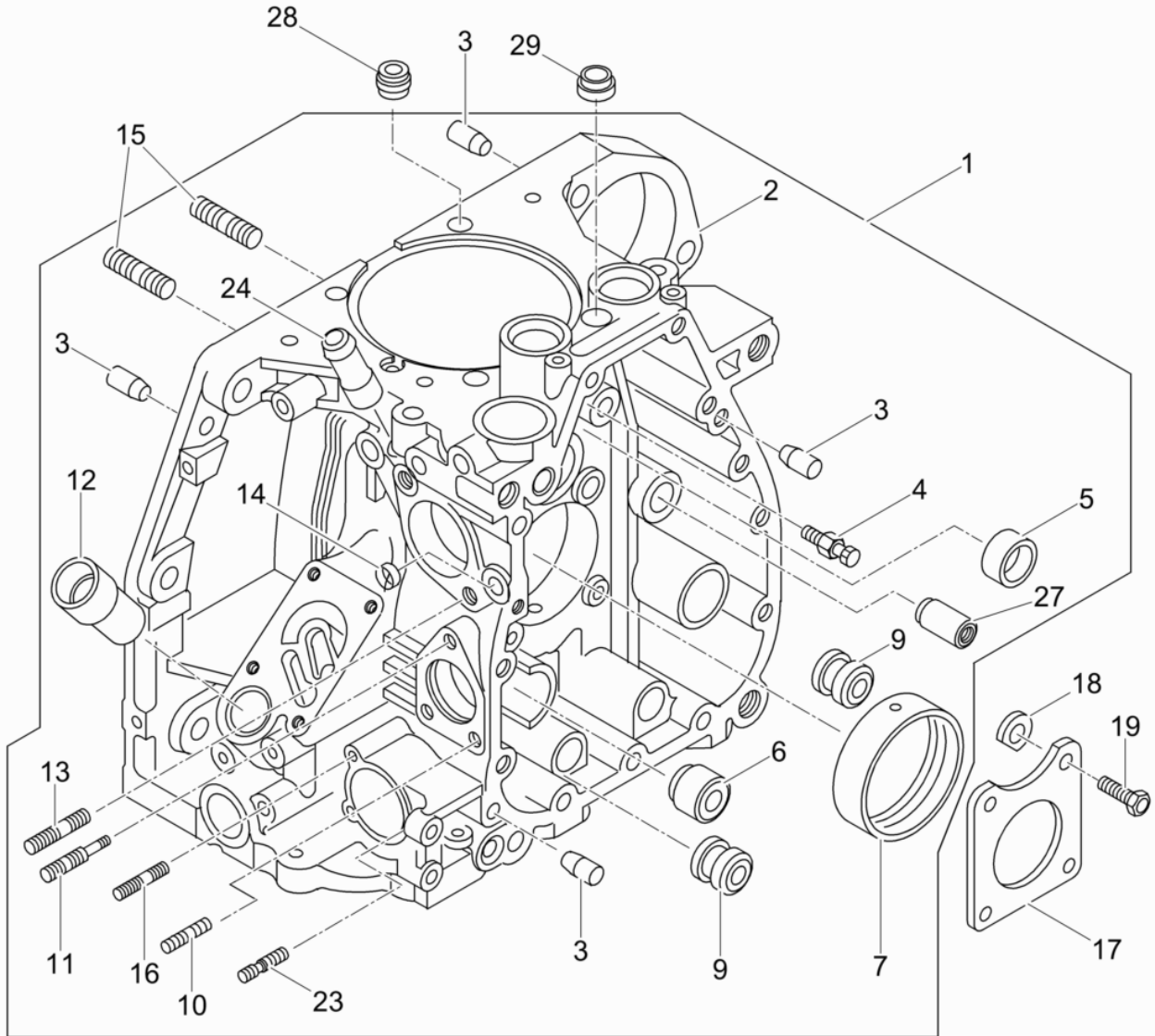

Ref. Pos.	Part No. Artikel Nr.	Qty. St.	Description Beschreibung	Descripción Description	Measurem./Abm.	Norm
					Torque/Drehm.	Sealant Schmierstoff
1	0126516	1	Crankcase Kurbelgehäuse	Cárter Carter manivelle		
3	0207615	4	Straight pin Zylinderstift	Pasador cilíndrico Goupille cylindrique	8x20	
4	0094922	1	Lubrication jet Schmiereinrichtung	Dispositivo de lubricación Dispositif de lubrification		
5	0094923	1	Bearing Gleitlager	Rodamiento Roulement		
6	0207596	1	Push-in plug Stopfen	Tapón Bouchon		
7	0094924	1	Bearing Gleitlager	Rodamiento Roulement		
8	0107228	1	Slide bearing Gleitlager	Cojinete deslizante Roulement de glissement	-0,5	
9	0207597	1	Push-in plug Stopfen	Tapón Bouchon		
10	0202433	2	Threaded bolt Gewindebolzen	Perno roscado Boulon fileté	M6 x 16	
11	0094925	1	Stud bolt Stiftschraube	Perno prisionero Boulon		
12	0099415	1	Oil fill tube Einfüllstutzen	Tubo llenador de aceite Tube-remplisseur d'huile		
13	0151526	2	Stud Stiftschraube	Perno prisionero Boulon	M8 x 25	DIN825
14	0202447	1	Washer Scheibe	Arandela Rondelle	A3C	
15	0107948	8	Stud Stiftschraube	Perno prisionero Boulon	M8 x 22	
16	0099414	2	Stud Stiftschraube	Perno prisionero Boulon	M6 x 22	
17	0098453	1	Check disc Anlaufscheibe	Arandela tope Disque		
18	0098455	1	Washer Scheibe	Arandela Rondelle	1,05	
18	0098454	1	Washer Scheibe	Arandela Rondelle	1,2	
19	0098456	4	Hexagonal head cap screw Sechskantschraube	Tornillo hexagonal Vis à tête hexagonale		
23	0099414	1	Stud Stiftschraube	Perno prisionero Boulon	M6 x 22	
27	0202406	1	Bush Buchse	Buje Boîte		
28	0126518	2	Rubber funnel Gummitülle	Casquillo de goma Passe fil en caoutchouc		
29	0097403	2	Grommet Gummitülle	Ojal Passe-fil		

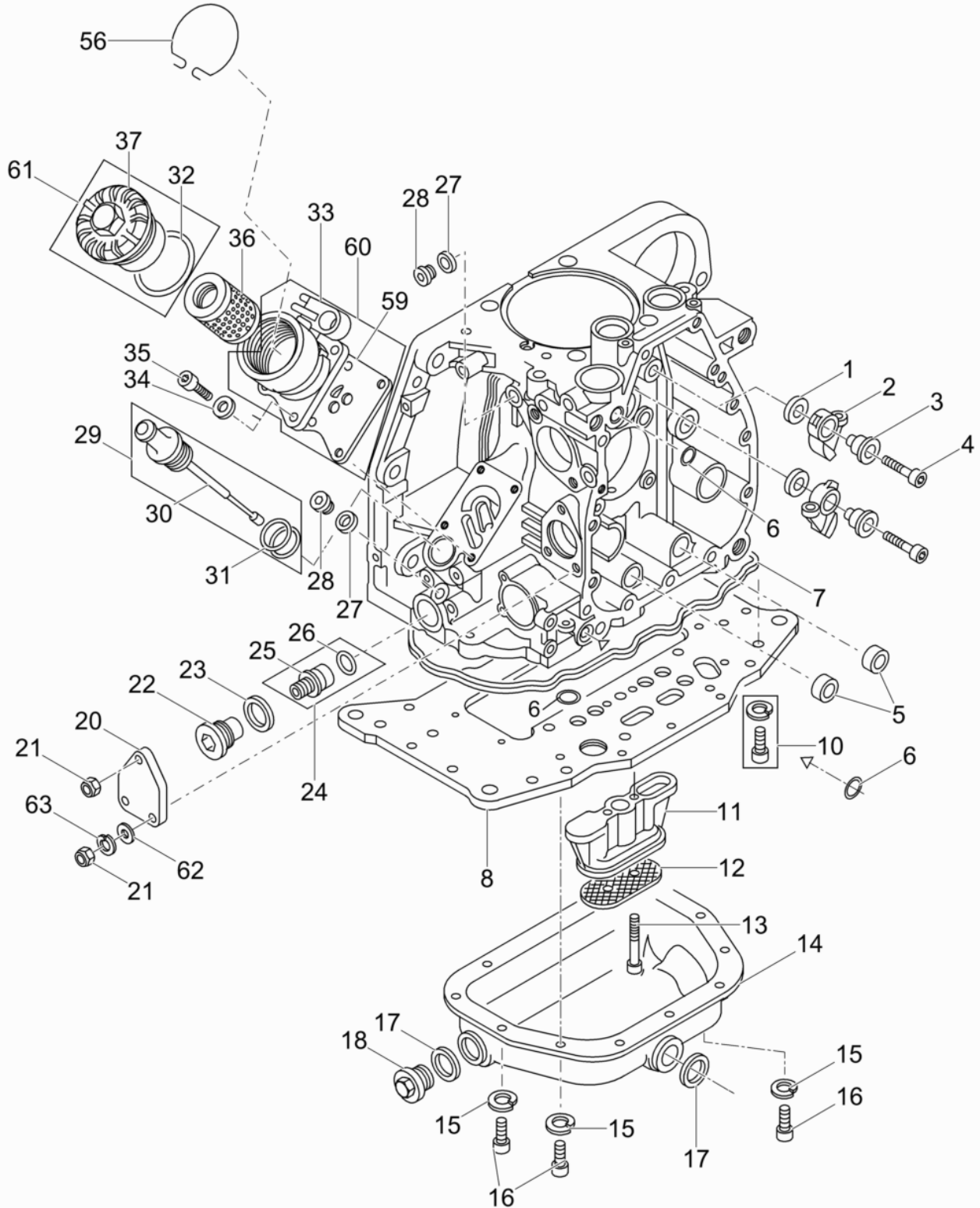

Ref. Pos.	Part No. Artikel Nr.	Qty. St.	Description Beschreibung	Descripción Description	Measurem./Abm.	Norm
					Torque/Drehm.	Sealant Schmierstoff
1	0104365	2	Washer Scheibe	Arandela Rondelle	10.1 x 22 x 3	
2	0094937	2	Sliding lever Schlepphebel	Palanca deslizante Levier glissant		
3	0094936	2	Cam follower spindle shaft Buchse	Rodillo de leva Contre-came		
4	0217112	2	Cheese head screw Zylinderschraube	Tornillo cilíndrico Vis à tête cylindrique	M6 x 30	
5	0094935	2	Washer Flachdichtring	Arandela Rondelle		
6	0094934	3	O-Ring O-Ring	Anillo-O Joint torique	9,5 x 2,5	
7	0094952	1	Gasket Dichtung	Junta Joint		
8	0094953	1	Plate Platte	Placa Plaque		
10	0202463	22	Hexagon socket head screw Innensechskantschraube	Tornillo a seis lados huecos Vis à six pans creux	M8 x 25	
11	0094954	1	Housing Sauggehäuse	Caja Carter		
12	0094955	1	Strainer Sieb	Tamizador Tamis		
13	0094956	2	Cheese head screw Zylinderschraube	Tornillo cilíndrico Vis à tête cylindrique	M6 x 50 10Nm/7ft.lbs	DIN6912
14	0094957	1	Cover Ölwanne	Tapa Couvercle		
15	0151456	12	Lock washer Federring	Arandela elástica Rondelle de ressort	6	DIN128
16	0202450	12	Hexagon socket head screw Innensechskantschraube	Tornillo a seis lados huecos Vis à six pans creux	M6 x 10	
17	0202416	2	Oil Seal Öldichtung	Junta de Aceite Joint D'Huile	52 x 80 x 10	
18	0094958	1	Plug (threaded) Verschlußschraube	Tapón roscado Bouchon	AM22 x 1,5	DIN7604
20	0207539	1	Cover Deckel	Tapa Couvercle		
21	0129021	3	Locknut Sechskantmutter	Contratuerca Contre-écrou	VM6	
22	0126921	1	Screw plug Verschlußschraube	Tornillo de cierre Vis de fermeture		
23	0094948	1	Gasket Dichtring	Anillo de junta Bague d'étanchéité	A24 x 29	DIN7603
24	0106530	1	Valve Ventil	Válvula Soupape		
26	0126922	1	O-ring O-Ring	Anillo-O Bague-O	18 x 2	
27	0071121	2	Sealing ring Dichtungsring	Anillo sellante Bague d'étanchéité	A10 x 13,5	
28	0151213	2	Screw plug Verschlußschraube	Tornillo de cierre Vis de fermeture	M10 X 1	DIN908

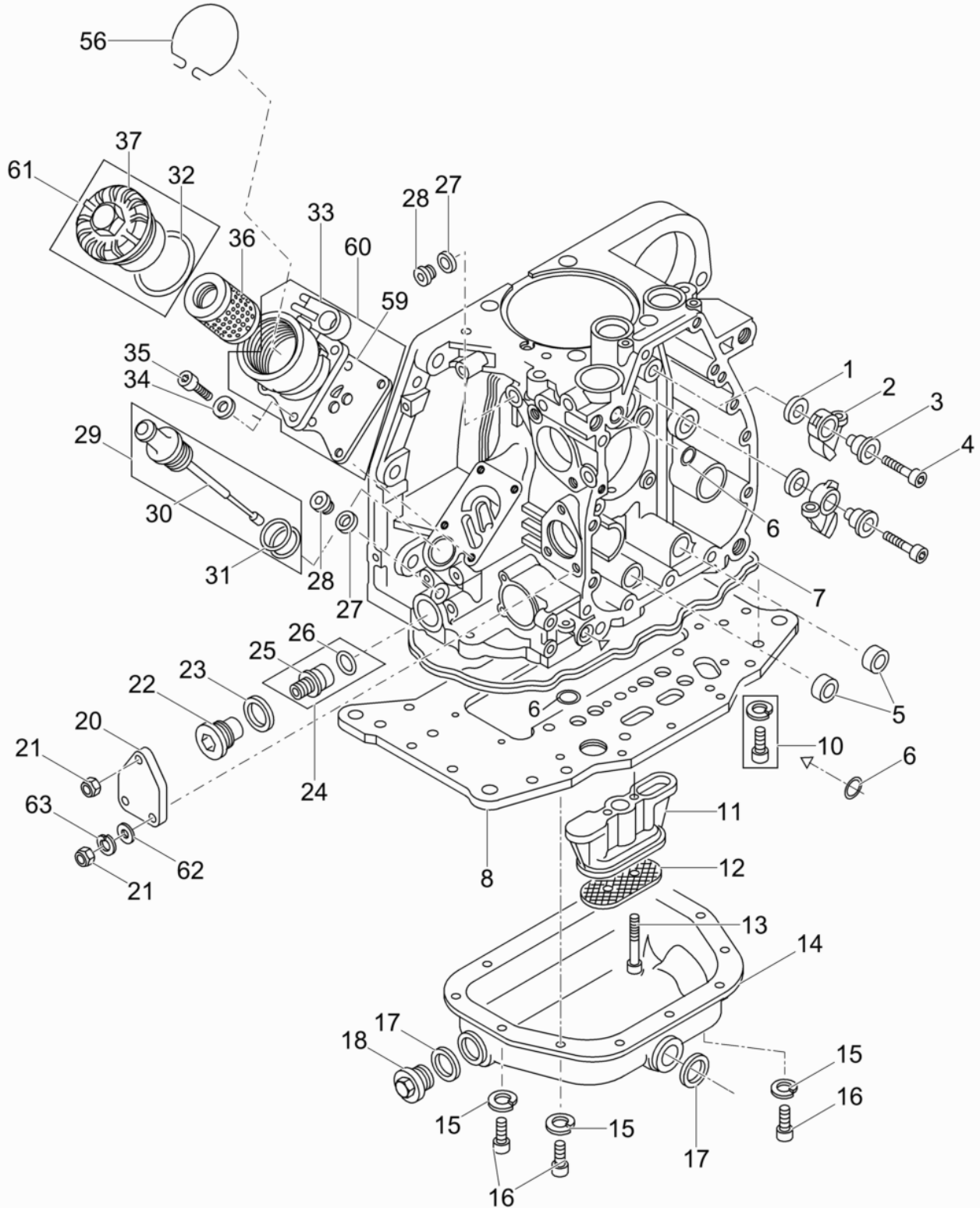

Ref. Pos.	Part No. Artikel Nr.	Qty. St.	Description Beschreibung	Descripción Description	Measurement./Abm.	Norm
					Torque/Drehm.	Sealant Schmierstoff
29	0094932	1	Dipstick Peilstab	Varilla indicadora Jauge d'huile		
31	0094933	2	O-Ring O-Ring	Anillo-O Joint torique		
32	0094928	1	Gasket Flachdichtring	Juntaaceite Joint		
34	0151290	4	Spring washer Federscheibe	Arandela elástica Rondelle à ressort	A6	DIN137
35	0202437	4	Cheese head screw Zylinderschraube	Tornillo cilíndrico Vis à tête cylindrique	M6 x 20	
36	0094930	1	Element Filterpatrone	Elemento Elément		
56	0104402	1	Spring Drahtfeder	Resorte Ressort		
59	0106559	1	Seal Dichtung	Junta Joint		
61	0094931	1	Cover Schraubdeckel	Tapa Couvercle		
62	0151324	2	Washer Scheibe	Arandela Rondelle	6.4	
63	0151456	2	Lock washer Federring	Arandela elástica Rondelle de ressort	6	DIN128

Crankshaft - Mounting flange
Kurbelwelle-Lagerflansch
Cigüeñal - Brida
Vilebrequin - Bourrelet

DPU 6555Hs

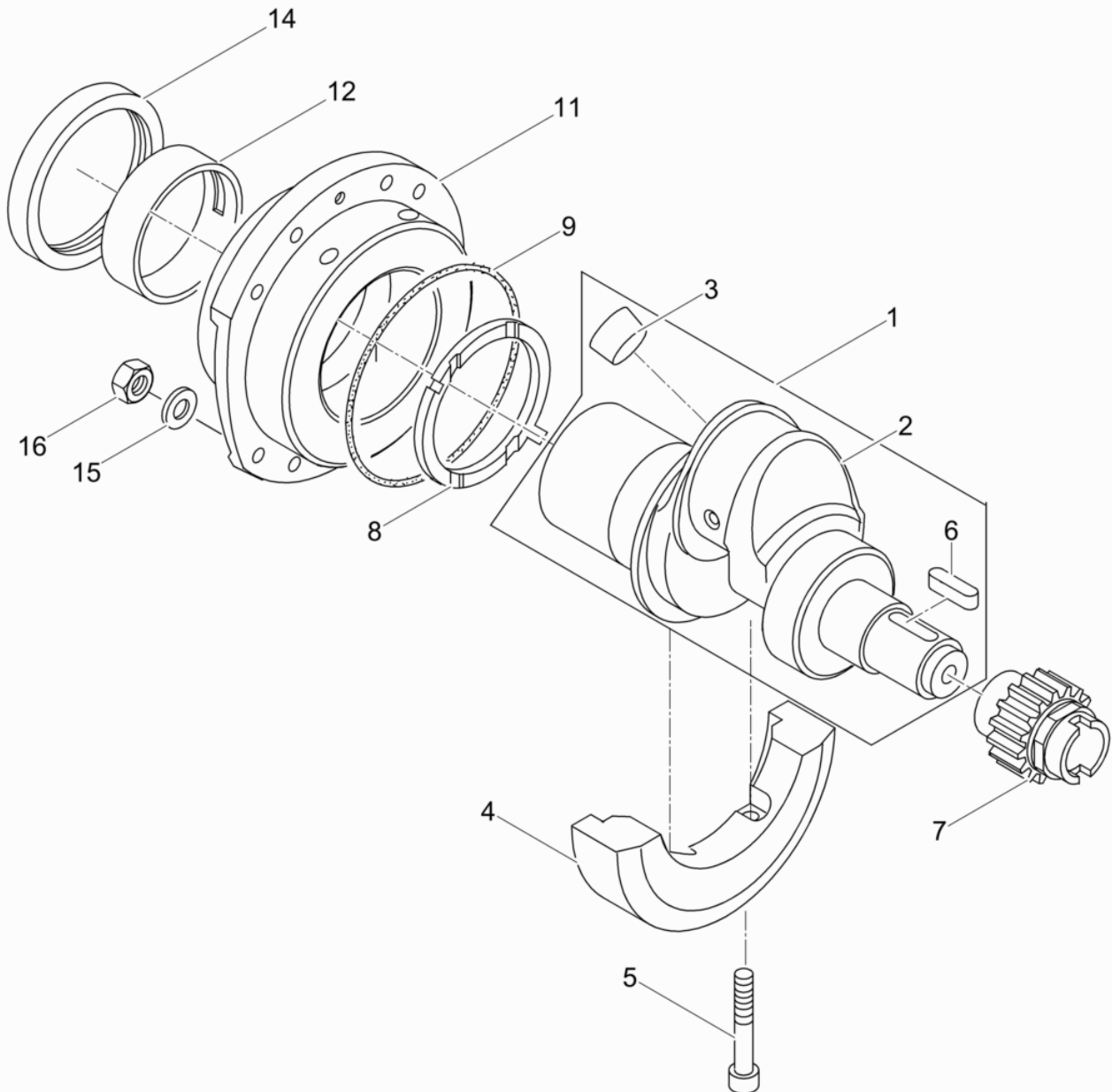

Ref. Pos.	Part No. Artikel Nr.	Qty. St.	Description Beschreibung	Descripción Description	Measurement./Abm.	Norm
					Torque/Drehm.	Sealant Schmierstoff
1	0094869	1	Crankshaft Kurbelwelle	Cigüeñal Vilebrequin		
3	0207600	1	Cover Deckel	Tapa Couvercle		
4	0094870	1	Counterweight Gegengewicht	Contrapeso Contrepoids		
5	0217110	2	Cheese head screw Zylinderschraube	Tornillo cilíndrico Vis à tête cylindrique	M10 x 50	
6	0094868	1	Fitting key Passfeder	Chaveta Clavette	A6 x 4 x 32	DIN6885
7	0106529	1	Pinion Ritzel	Piñón Pignon		
8	0094872	1	O-Ring O-Ring	Anillo-O Joint torique		
9	0094872	1	O-Ring O-Ring	Anillo-O Joint torique		
11	0128939	1	Bearing flange Lagerflansch	Brida-rodamiento Collerette-roulement		
12	0094874	1	Bearing Gleitlager	Rodamiento Roulement		
13	0107223	1	Slide bearing Gleitlager	Cojinete deslizante Roulement de glissement	-0,5	
14	0094875	1	Shaft seal Wellendichtring	Sello del eje Bague d'étanchéité		
15	0202460	8	Washer Scheibe	Arandela Rondelle	8,4	
16	0094876	8	Hexagon nut Sechskantmutter	Tuerca hexagonal Écrou hexagonal	M8	ISO4032

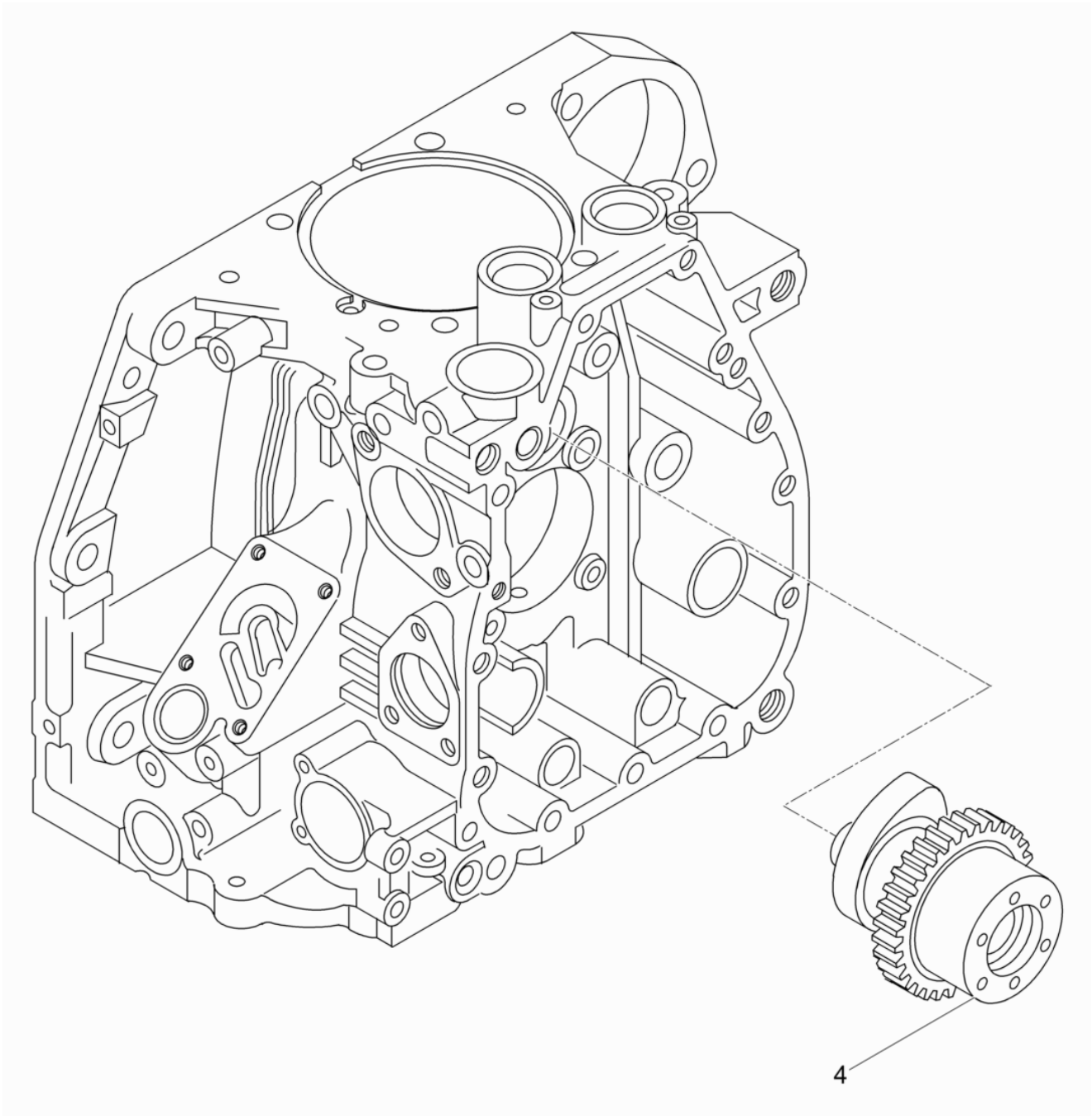

Ref. Pos.	Part No. Artikel Nr.	Qty. St.	Description Beschreibung	Descripción Description	Measurement./Abm.	Norm
					Torque/Drehm.	Sealant Schmierstoff
4	0207584	1	Camshaft Nockenwelle	Arbol de levas Arbre à cames		

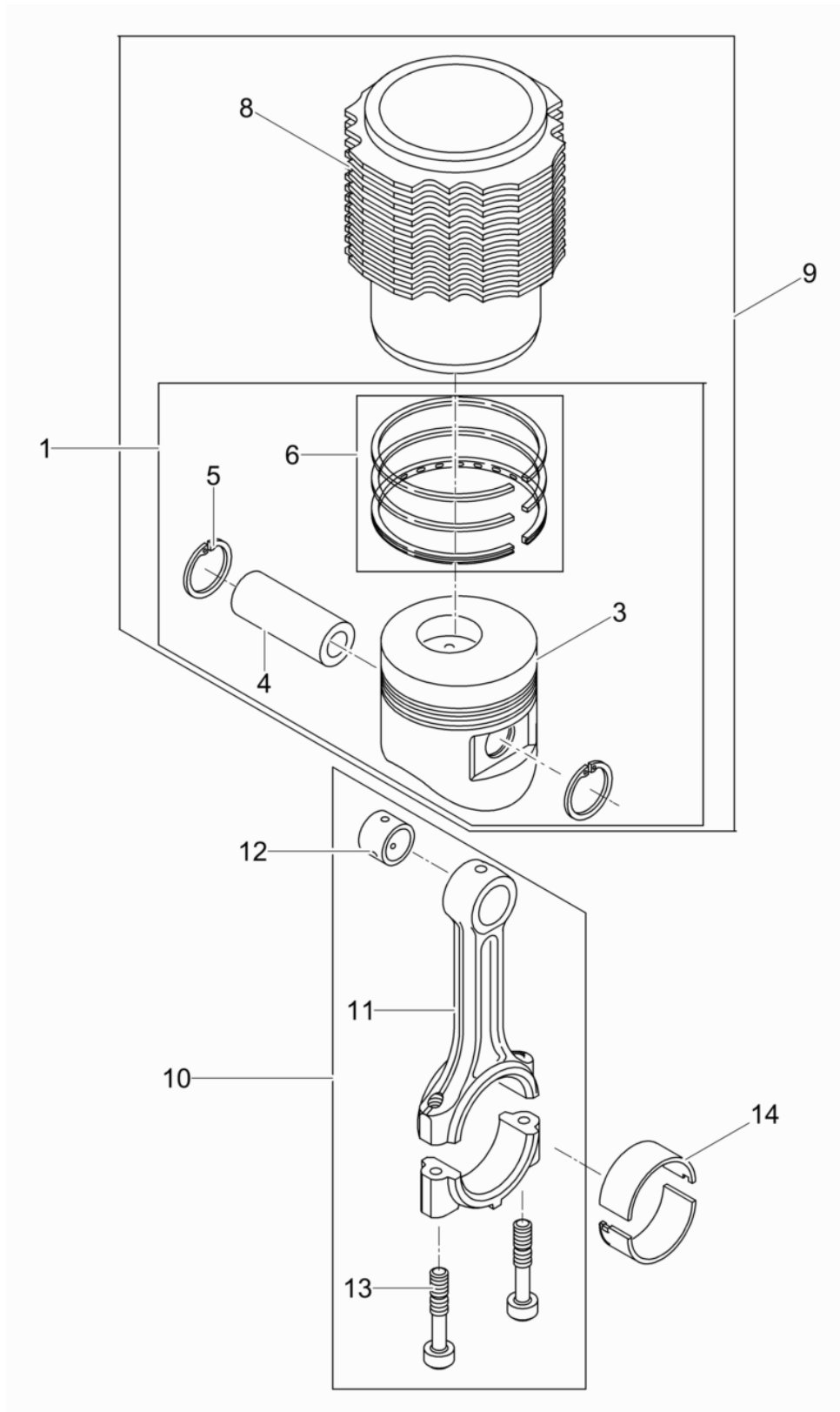

Ref. Pos.	Part No. Artikel Nr.	Qty. St.	Description Beschreibung	Descripción Description	Measurem./Abm.	Norm
					Torque/Drehm.	Sealant Schmierstoff
1	0217087	1	Piston Kolben	Pistón Piston		
4	0094862	1	Piston pin Kolbenbolzen	Pasador de pistón Axe de piston		
5	2001695	2	Retaining ring Sicherungsring	Anillo de retención Bague d'arrêt	30 x 1,2	DIN472
6	0217086	1	Set-piston rings Kolbenringsatz	Juego de anillos Jeu de segments		
9	0217089	1	Cylinder with piston Zylinder mit Kolben	Cilindro con pistón Cylindre avec piston		
10	0094863	1	Connecting rod compl Pleuel kpl.	Biela compl. Bielle compl.		
12	0094864	1	Bushing Pleuelbuchse	Buje Douille		
13	0105927	2	Connecting rod screw Pleuelschraube	Tornillo de la biela Vis de bielle		
14	0094866	1	Bearing Pleuellager	Rodamiento Roulement		
15	0107222	1	Connecting rod bearing Pleuellager	Cojinete de la biela Coussinet de bielle	-0,5	

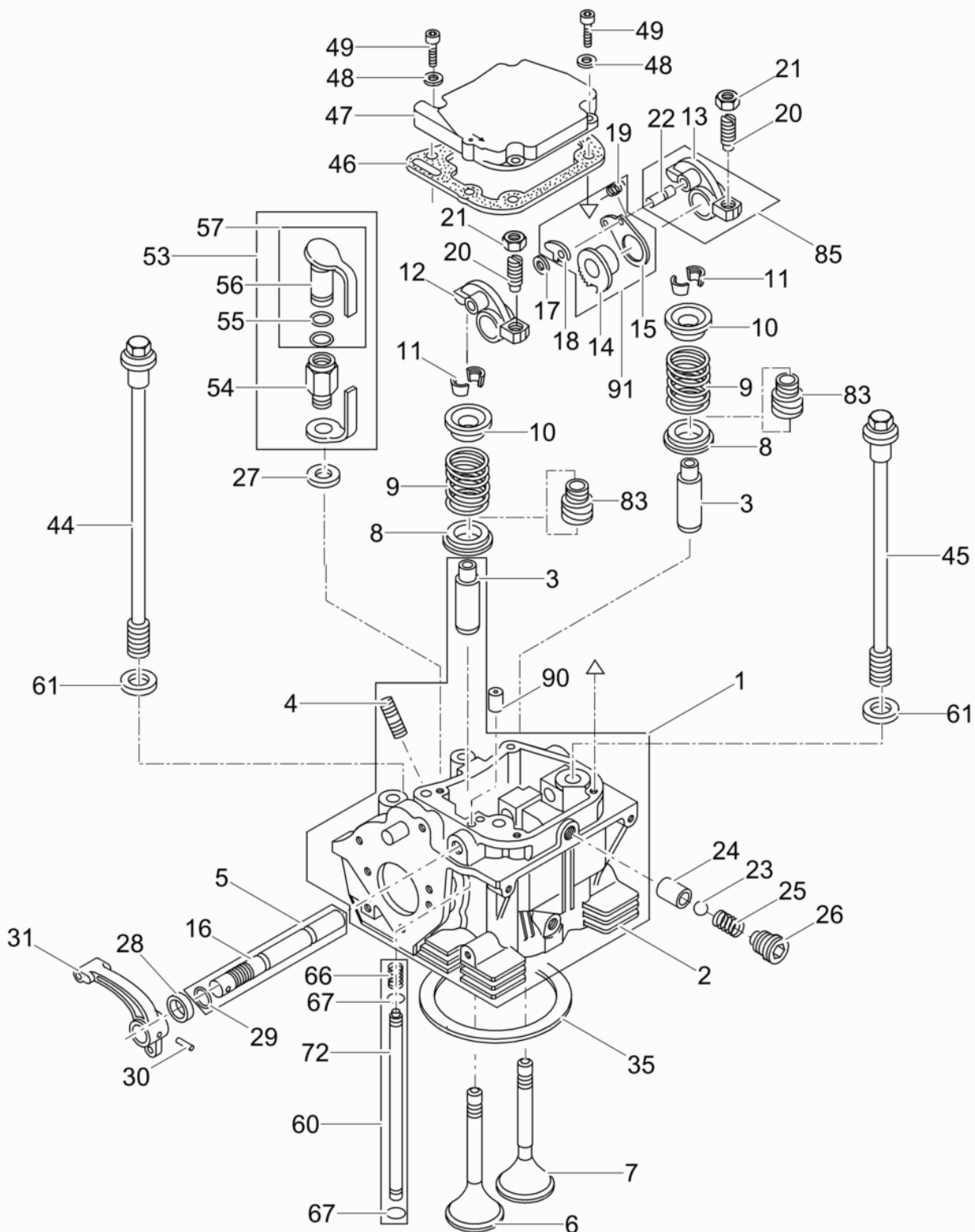

Ref. Pos.	Part No. Artikel Nr.	Qty. St.	Description Beschreibung	Descripción Description	Measurem./Abm.	Norm
					Torque/Drehm.	Sealant Schmierstoff
1	0126515	1	Cylinder head Zylinderkopf	Culata Culasse		
3	0094890	2	Valve guide Ventilführung	Guiaválvula Guide de soupape		
4	0207595	1	Stud Stiftschraube	Perno prisionero Boulon	M8 x 35	
5	0105928	1	Rocker shaft Kipphebelachse	Eje de la balancín Axe de culbuteur		
6	0105043	1	Intake valve Einlassventil	Válvula de admisión Soupape d'admission		
7	0105044	1	Exhaust valve Auslaßventil	Válvula de escape Soupape d'échappement		
8	0094902	2	Washer Scheibe	Arandela Rondelle		
9	0094901	2	Spring Ventilfeder	Resorte Ressort		
10	0094900	2	Spring holder Federteller	Soporte Support		
11	0094899	2	Set-taper cone valve Ventilkonussatz	Juego-cono de válvula Jeu-cone de soupape		
12	0098449	1	Inlet rocker arm Einlaßkippebel	Balancín de admisión Culbuteur		
15	0094895	1	Holder Halter	Soporte Attache		
17	0202427	1	Lock washer Sicherungscheibe	Arandela de seguridad Rondelle d'arrêt		
18	0094897	1	Ratchet (pawl) Mitnehmer	Trinquete Cliquet		
19	0094894	1	Spring Feder	Resorte Ressort		
20	0094891	2	Adjustment screw Einstellschraube	Tornillo de ajuste Vis d'ajustage		
21	4101500	2	Locknut Sechskantmutter	Contratuercas Contre-écrou	5/16 x 24in	
23	0066801	1	Ball Kugel	Bola Bille		
24	0094886	1	Bushing Buchse	Buje Douille		
25	0094887	1	Spring Feder	Resorte Ressort		
26	0094886	1	Bushing Buchse	Buje Douille		
27	0013186	1	Gasket Dichtring	Anillo de junta Bague d'étanchéité	A12 x 15,5	DIN7603
28	0097401	1	Seal Dichtscheibe	Empaque Joint		
29	0108801	1	O-ring O-Ring	Anillo-O Bague-O	8 x 2	
30	0013587	1	Spring pin Spannstift	Pasador de sujeción Goupille élastique	4 x 20	

Cylinder head
 Zylinderkopf
 Tapa del cilindro
 Culasse

DPU 6555Hs

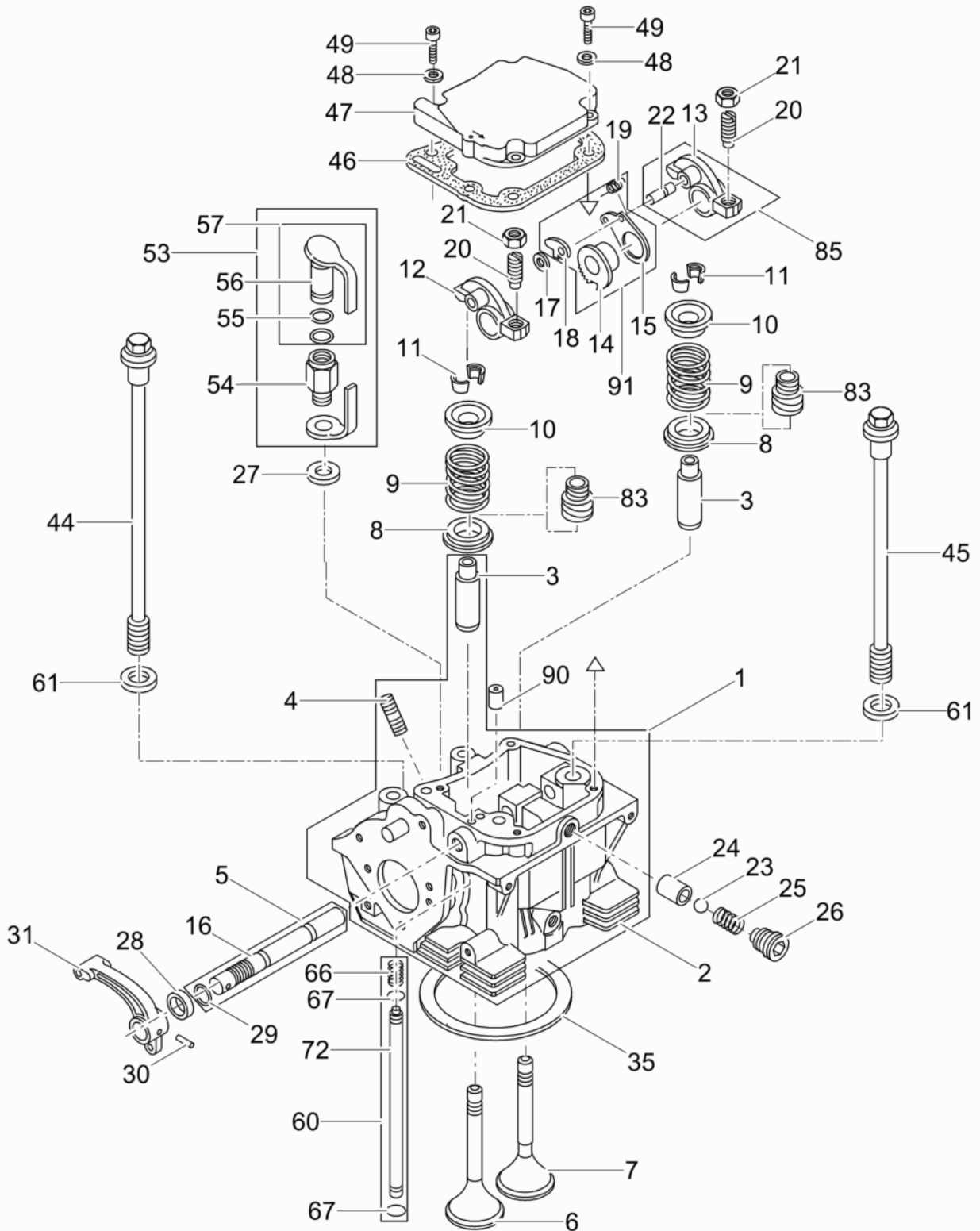

Ref. Pos.	Part No. Artikel Nr.	Qty. St.	Description Beschreibung	Descripción Description	Measurem./Abm.	Norm
					Torque/Drehm.	Sealant Schmierstoff
31	0094909	1	Decompression lever Hebel	Palanca de descompresión Manette de decompression		
35	0099413	1	Cylinder head gasket Zylinderkopfdichtung	Junta de culata del cilindro Joint de culasse de cylindre	0,5	
35	0207552	1	Cylinder head gasket Zylinderkopfdichtung	Junta de culata del cilindro Joint de culasse de cylindre	1,25	
35	0207551	1	Cylinder head gasket Zylinderkopfdichtung	Junta de culata del cilindro Joint de culasse de cylindre	1,15	
35	0207550	1	Cylinder head gasket Zylinderkopfdichtung	Junta de culata del cilindro Joint de culasse de cylindre	1,05	
35	0207549	1	Cylinder head gasket Zylinderkopfdichtung	Junta de culata del cilindro Joint de culasse de cylindre	0,95	
35	0207548	1	Cylinder head gasket Zylinderkopfdichtung	Junta de culata del cilindro Joint de culasse de cylindre	0,85	
35	0207547	1	Cylinder head gasket Zylinderkopfdichtung	Junta de culata del cilindro Joint de culasse de cylindre	0,75	
35	0207546	1	Cylinder head gasket Zylinderkopfdichtung	Junta de culata del cilindro Joint de culasse de cylindre	0,65	
35	0207545	1	Cylinder head gasket Zylinderkopfdichtung	Junta de culata del cilindro Joint de culasse de cylindre	0,55	
35	0094920	1	Cylinder head gasket Zylinderkopfdichtung	Junta de culata del cilindro Joint de culasse de cylindre	1,3	
35	0094919	1	Cylinder head gasket Zylinderkopfdichtung	Junta de culata del cilindro Joint de culasse de cylindre	1,2	
35	0094918	1	Cylinder head gasket Zylinderkopfdichtung	Junta de culata del cilindro Joint de culasse de cylindre	1,1	
35	0094917	1	Cylinder head gasket Zylinderkopfdichtung	Junta de culata del cilindro Joint de culasse de cylindre	1,0	
35	0094916	1	Cylinder head gasket Zylinderkopfdichtung	Junta de culata del cilindro Joint de culasse de cylindre	0,9	
35	0094915	1	Cylinder head gasket Zylinderkopfdichtung	Junta de culata del cilindro Joint de culasse de cylindre	0,8	
35	0094914	1	Cylinder head gasket Zylinderkopfdichtung	Junta de culata del cilindro Joint de culasse de cylindre	0,7	
35	0094913	1	Cylinder head gasket Zylinderkopfdichtung	Junta de culata del cilindro Joint de culasse de cylindre	0,6	
44	0094881	2	Screw Zylinderkopfschraube	Tornillo Vis		
45	0094882	2	Screw Zylinderkopfschraube	Tornillo Vis		
46	0098445	1	Gasket Dichtung	Junta Joint		
47	0098444	1	Cover Deckel	Tapa Couvercle		
48	0151290	4	Spring washer Federscheibe	Arandela elástica Rondelle à ressort	A6	DIN137
49	0129010	4	Cheese head screw Zylinderschraube	Tornillo cilíndrico Vis à tête cylindrique	M6 x 25	DIN912
53	0102468	1	Fuel primer Dosiereinrichtung	Imprimador Dispositif d'injection au		

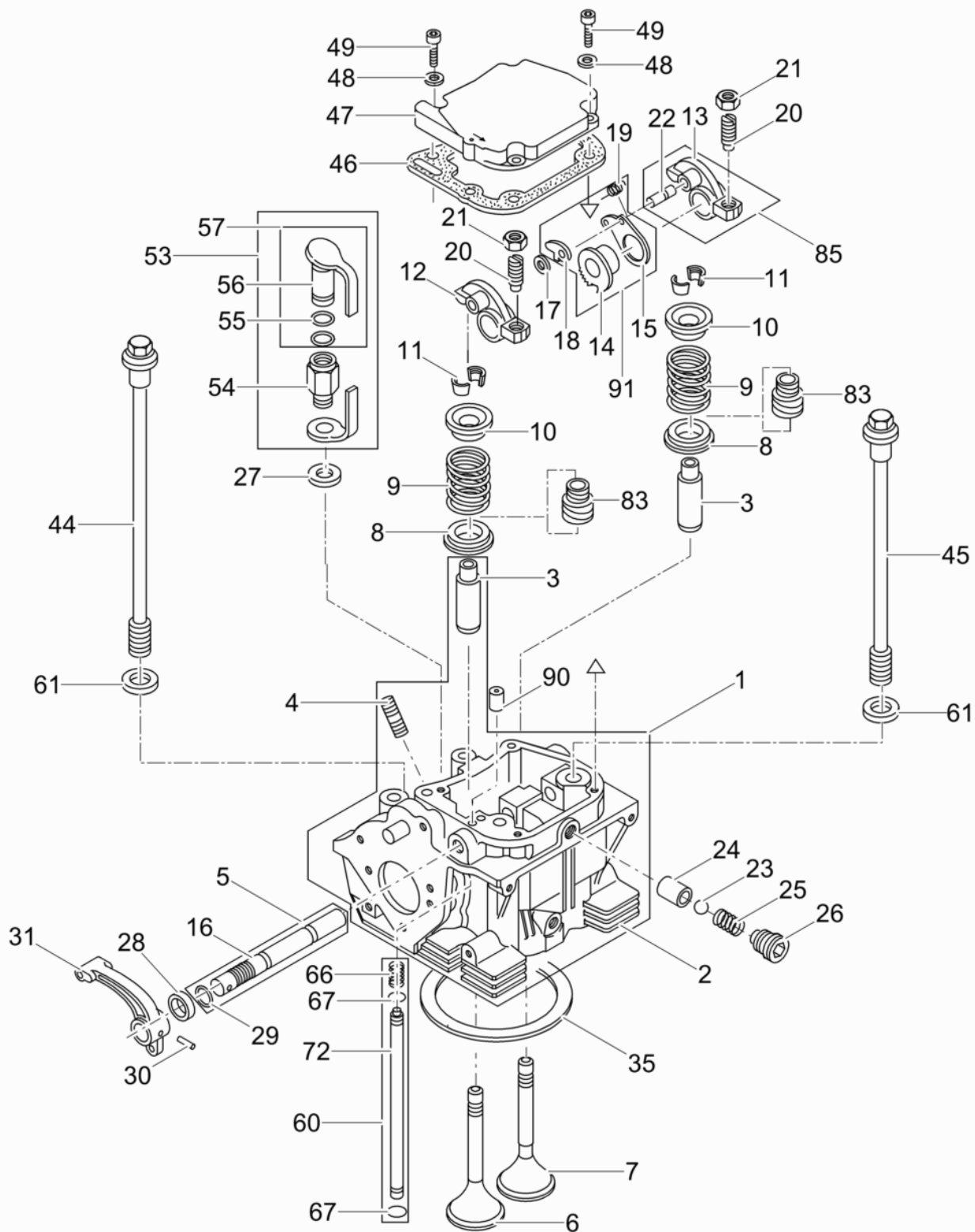

Ref. Pos.	Part No. Artikel Nr.	Qty. St.	Description Beschreibung	Descripción Description	Measurement./Abm.	Norm
					Torque/Drehm.	Sealant Schmierstoff
55	0107390	2	O-Ring O-Ring	Anillo-O Joint torique	11,3 x 2,4	
57	0102469	1	Plug (threaded) Verschlußstopfen	Tapón roscado Bouchon		
60	0094906	1	Grease tube Schmierrohr	Tubo de grasa Tube de graisse		
61	0104388	4	Washer Scheibe	Arandela Rondelle	2,5	
66	0094903	1	Spring Feder	Resorte Ressort		
67	0094905	2	O-Ring O-Ring	Anillo-O Joint torique		
83	5100010410	2	Seal Abdichtung	Junta Joint		
85	0098448	1	Exhaust rocker arm Auslaßkipphebel	Balancín de escape Culbuteur		
90	0207538	1	Jet Düse	Gicleur Gicleur		
91	0126917	1	Toothed segment cpl. Zahnsegment kpl.	Segmento dentado cpl. Secteur dentée cpl.		

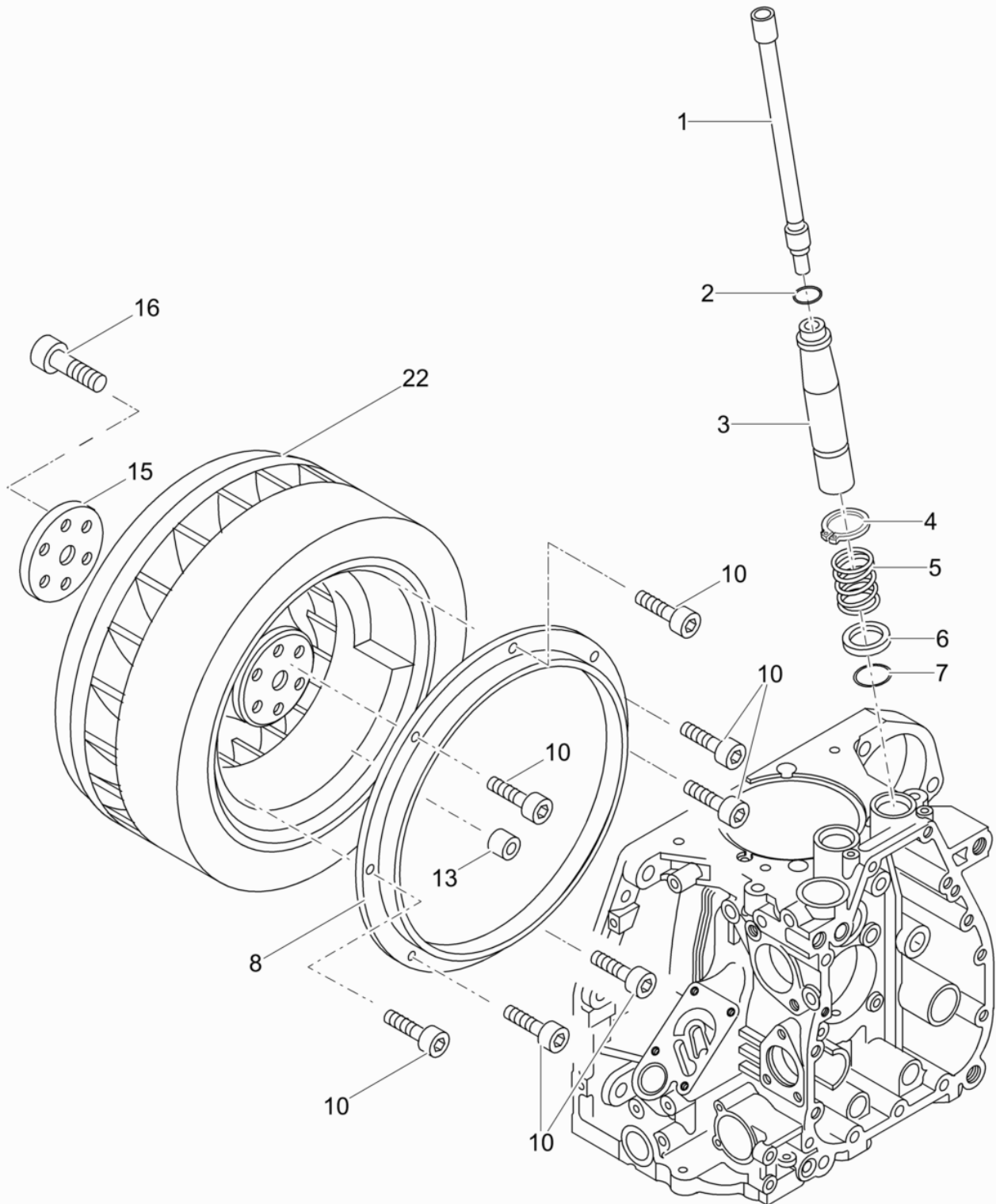

Ref. Pos.	Part No. Artikel Nr.	Qty. St.	Description Beschreibung	Descripción Description	Measurement./Abm.	Norm
					Torque/Drehm.	Sealant Schmierstoff
1	0098457	2	Push rod (valve lifter) Stoßstange	Levantaválvula Poussoir de soupape		
2	0094944	2	O-Ring O-Ring	Anillo-O Joint torique		
3	0094943	2	Pipe Rohr	Tubo Tube		
4	0094942	2	Retaining ring Sicherungsring	Anillo de retención Bague d'arrêt	24 x 1,75	DIN471
5	0094941	2	Spring Feder	Resorte Ressort		
6	0094940	2	Washer Scheibe	Arandela Rondelle		
7	0094939	2	O-Ring O-Ring	Anillo-O Joint torique		
8	0217115	1	Ring Ring	Anillo Anneau		
10	0151341	7	Cheese head screw Zylinderschraube	Tornillo cilíndrico Vis à tête cylindrique	M4 x 10	ISO4762
13	0095044	1	Sleeve Fixierhülse	Manguito Douille		
15	0095045	1	Disc holder Fixierscheibe	Disco Disque		
16	0095046	6	Cheese head screw Zylinderschraube	Tornillo cilíndrico Vis à tête cylindrique	M12 x 1,5 x 40 120Nm/89ft.lbs	ISO4762
22	0217116	1	Flywheel Schwungrad	Volante Volant		

Oil Pump-Governor
Ölpumpe-Regler
Bomba de Aceite-Regulador
Pompe à Huile-Régulateur

DPU 6555Hs

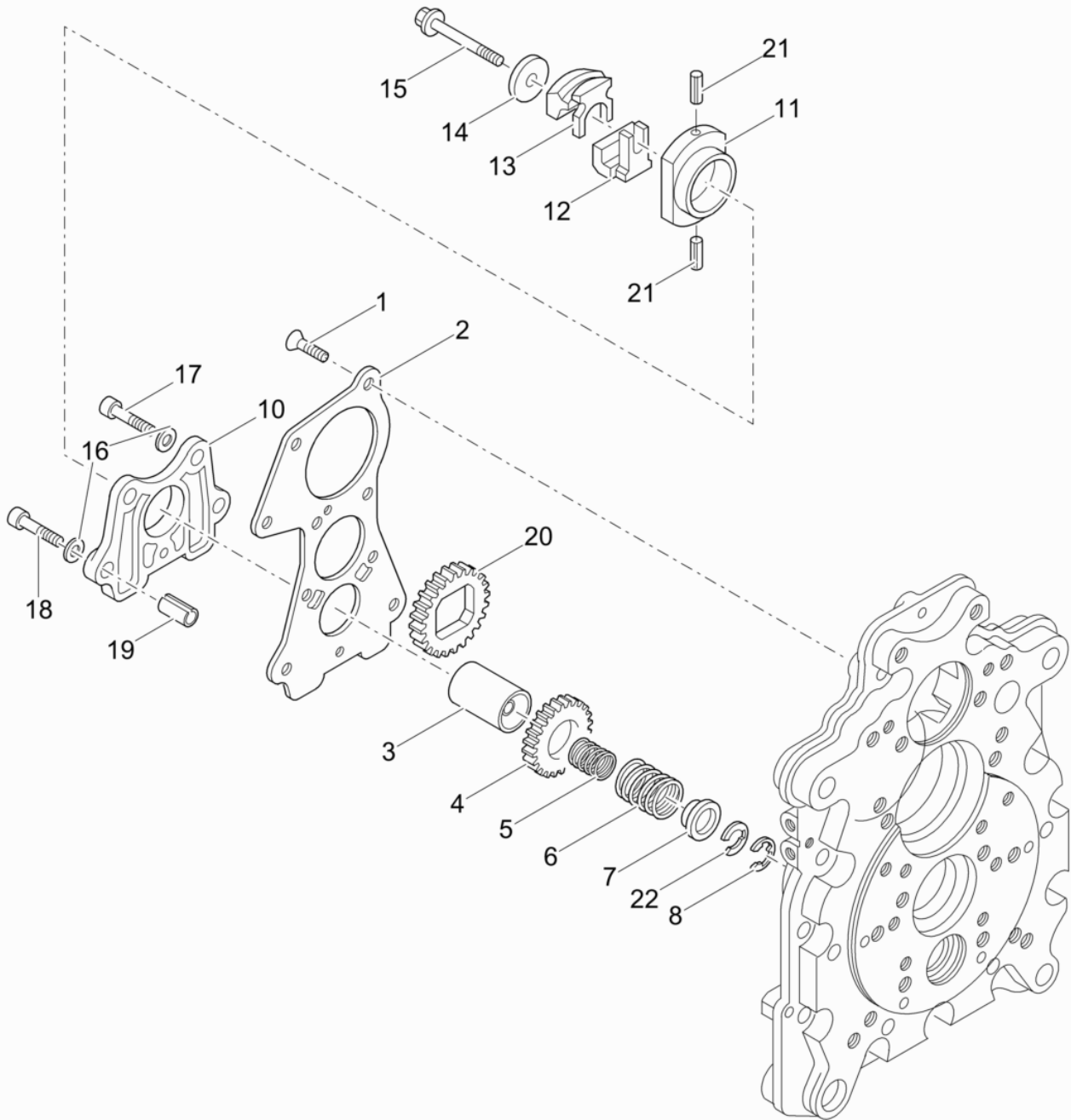

Ref. Pos.	Part No. Artikel Nr.	Qty. St.	Description Beschreibung	Descripción Description	Measurem./Abm.	Norm
					Torque/Drehm.	Sealant Schmierstoff
1	0095000	5	Screw Senkschraube	Tornillo Vis		
2	0094999	1	Cover Flanschdeckel	Tapa Couvercle		
3	0095002	1	Bushing Lagerbuchse	Buje Douille		
4	0106532	1	Gear wheel Zahnrad	Engranaje Roue dentée		
6	0095004	1	Spring Feder	Resorte Ressort		
7	0095005	1	Spring holder Federteller	Soporte Support		
8	2004956	1	Lock washer Sicherungsscheibe	Arandela de seguridad Rondelle d'arrêt	5	DIN6799
10	0217097	1	Housing Gehäuse	Carcasa Enveloppe		
11	5100002769	1	Bracket Träger	Soporte Support		
12	5100002771	2	Bolt Bolzen	Perno Boulon		
13	5100002770	2	Eccentric weight Fliehgewicht	Peso centrífugo Poids centrifuge		
14	0094991	1	Washer Scheibe	Arandela Rondelle		
15	0094990	1	Bolt Bolzen	Perno Boulon		
16	0151290	5	Spring washer Federscheibe	Arandela elástica Rondelle à ressort	A6	DIN137
17	0129010	3	Cheese head screw Zylinderschraube	Tornillo cilíndrico Vis à tête cylindrique	M6 x 25	DIN912
18	0202422	2	Hexagon socket head screw Innensechskantschraube	Tornillo a seis lados huecos Vis à six pans creux	M6 x 30	
19	0107546	2	Roll pin Spannstift	Pasador Goupille de tension	8 x 12	
20	0106531	1	Gear wheel Zahnrad	Engranaje Roue dentée		
21	5100002772	2	Lock washer Sicherungsscheibe	Arandela de seguridad Rondelle d'arrêt		
22	0099416	1	Washer Scheibe	Arandela Rondelle	0,5	
22	0217100	1	Washer Scheibe	Disco Rondelle	0,3	

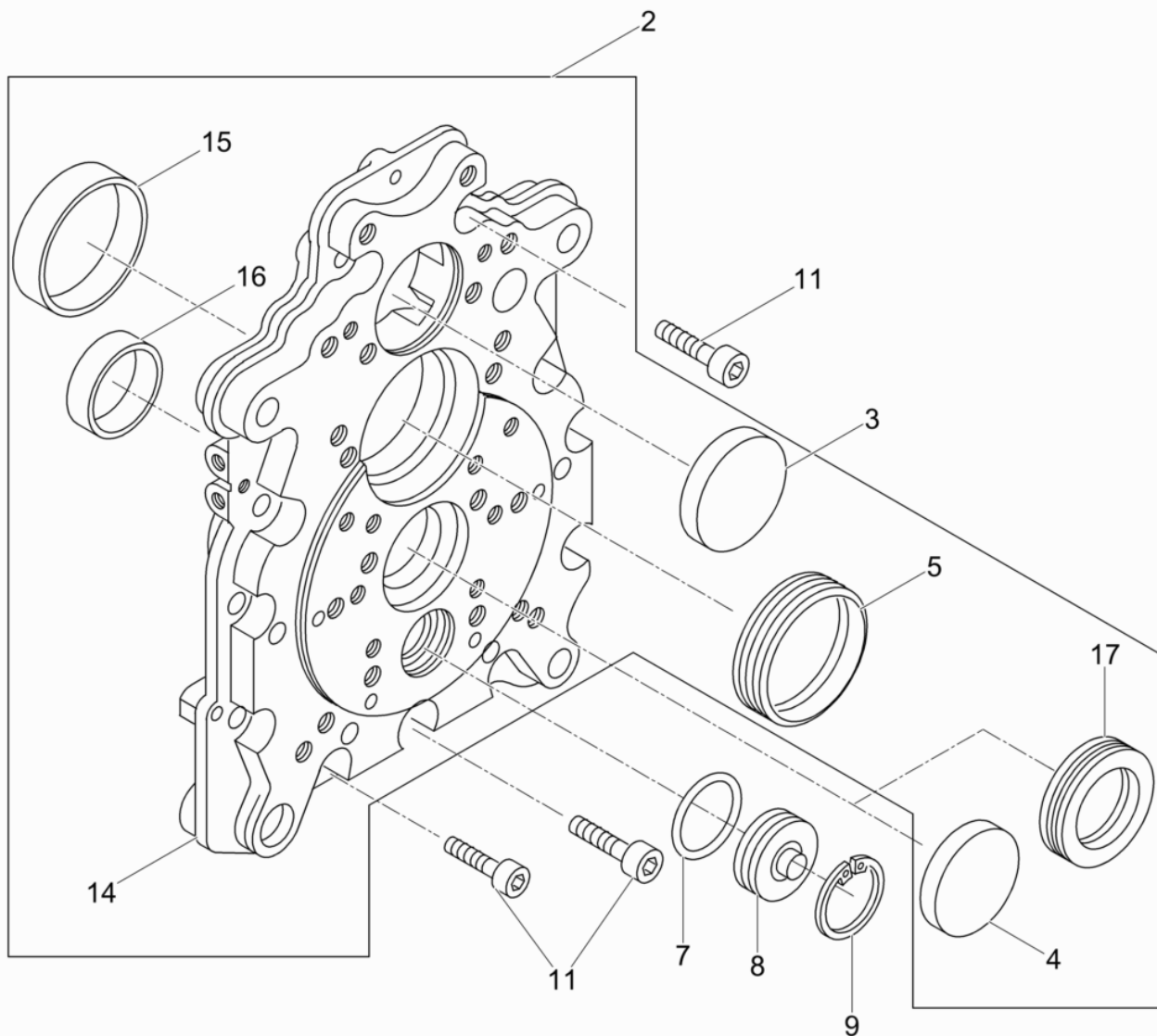

Ref. Pos.	Part No. Artikel Nr.	Qty. St.	Description Beschreibung	Descripción Description	Measurement./Abm.	Norm
					Torque/Drehm.	Sealant Schmierstoff
2	0207594	1	Command Cover Steuerdeckel	Tapa del mando Couvercle de commande		
3	0095014	1	Cover Verschlußdeckel	Tapa Couvercle		
4	0095015	1	Cover Verschlußdeckel	Tapa Couvercle		
5	0095013	1	Shaft seal Wellendichtring	Sello del eje Bague d'étanchéité		
7	0095016	1	O-Ring O-Ring	Anillo-O Joint torique		
8	0095017	1	Cover Deckel	Tapa Couvercle		
9	0202455	1	Retaining ring Sicherungsring	Anillo de retención Bague d'arrêt	32 x 1,2	
15	0202462	13	Hexagon socket head screw Innensechskantschraube	Tornillo a seis lados huecos Vis à six pans creux	M8 x 30	
16	0202385	1	Bearing bush Lagerbuchse	Casquillo del cojinete Bôte de roulement		
17	0207607	1	Rotary shaft seal Wellendichtring	Anillo de retén radial Bague d'étanchéité		

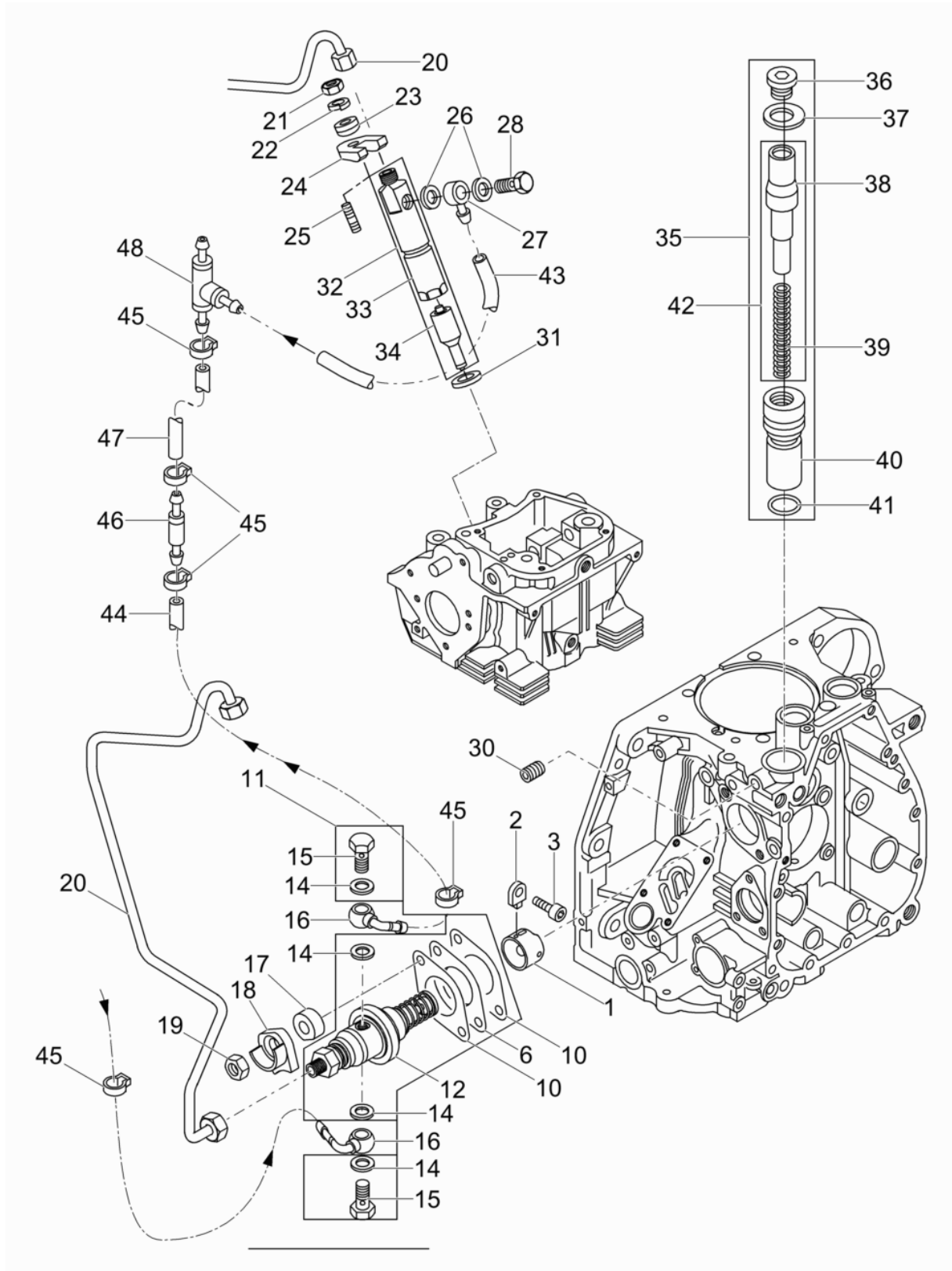

Ref. Pos.	Part No. Artikel Nr.	Qty. St.	Description Beschreibung	Descripción Description	Measurem./Abm.	Norm
					Torque/Drehm.	Sealant Schmierstoff
1	0126525	1	Tappet Stößel	Botador Poussoir		
2	0126526	1	Guide Führung	Guía Guide		
3	0207610	1	Cheese head screw Zylinderschraube	Tornillo cilíndrico Vis à tête cylindrique	M6 x 16	
6	0014482	1	Shim Ausgleichsscheibe	Laminilla Cale	0,3	
6	0207532	1	Shim Ausgleichsscheibe	Laminilla Cale	0,6	
6	0207533	1	Shim Ausgleichsscheibe	Laminilla Cale	0,9	
6	0207534	1	Shim Ausgleichsscheibe	Laminilla Cale	1,2	
10	0099419	2	Gasket Dichtung	Junta Joint	0.1	
10	0207544	2	Gasket Dichtung	Junta Joint	0.3	
10	0207543	2	Gasket Dichtung	Junta Joint	0.2	
11	0207559	1	Injection Pump Einspritzpumpe	Bomba Inyectora Pompe d'Injection		
14	0215374	4	Seal ring Dichtring	Anillo sellante Bague d'étanchéité		
15	0210452	2	Hollow screw Hohlschraube	Tornillo hueco Boulon creux à filet femelle	M 8 x 1	
16	0207809	1	Screw nipple Anschraubnippel	Boquilla roscada Raccord de vissage		
17	0207555	2	Spacer Distanzstück	Pieza distanciadora Pièce d'écartement		
18	0207592	2	Clamping clamp Spannpratze	Abrazadera de Clamping Bride de Clamping		
20	0207571	1	Pipe Kraftstoffdruckrohr	Tubo Tube		
21	0151379	1	Locknut Sechskantmutter	Contratuercas Contre-écrou	M8	ISO4032
22	0151218	1	Lock washer Federring	Arandela elástica Rondelle de ressort	8	
23	0095021	1	Disc Kugelscheibe	Disco Disque		
24	0207564	1	Flange Flansch	Brida Bride		
25	0207595	1	Stud Stiftschraube	Perno prisionero Boulon	M8 x 35	
26	0128957	2	Gasket Dichtring	Anillo de junta Bague d'étanchéité		
27	0095020	1	Fitting Nippel	Unión Raccord		
28	0095019	1	Banjo bolt Hohlschraube	Perno hueco Boulon creux à filet femelle		

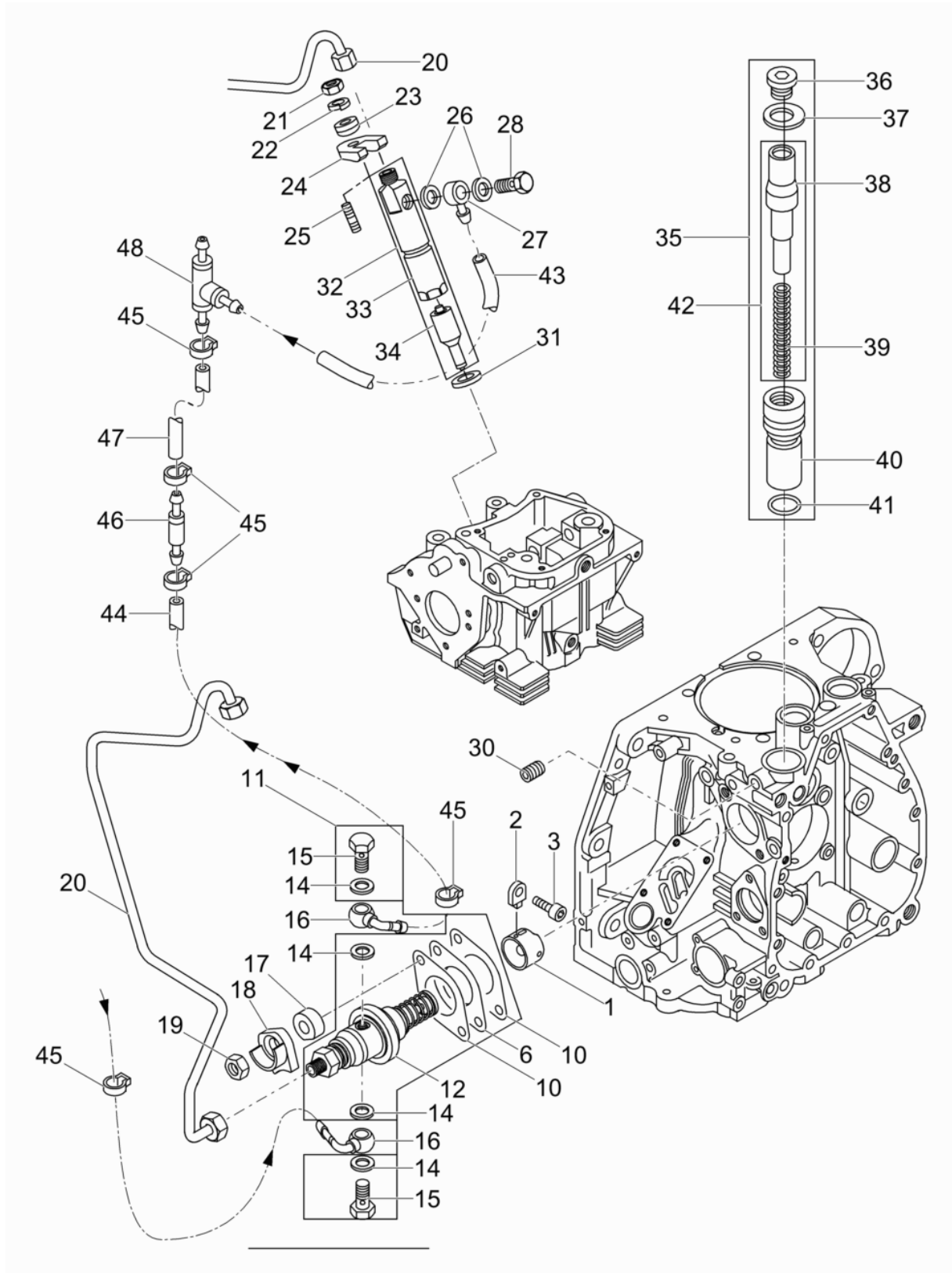

Ref. Pos.	Part No. Artikel Nr.	Qty. St.	Description Beschreibung	Descripción Description	Measurement/Abm.	Norm
					Torque/Drehm.	Sealant Schmierstoff
30	0020348	1	Threaded pin Gewindestift	Varilla roscada Goupille fileté	M8 x 16	DIN916
31	0217099	1	Seal ring Dichtring	Anillo sellante Bague d'étanchéité		
32	0217113	1	Injection Valve cpl. Einspritzventil kpl.	Válvula de Inyección cpl. Soupape de Injection cpl.		
34	0217114	1	Jet Düse	Chicler Gicleur		
35	0095007	1	Housing Gehäuse	Carcasa Carter		
36	0207601	1	Screw Plug Verschlußschraube	Tapón Roscado Vis de Fermeture		
37	0095006	1	Washer Scheibe	Arandela Rondelle		
39	0207556	1	Spring Feder	Resorte Ressort		
40	0207609	1	Housing Gehäuse	Carcasa Carter		
41	0095008	1	O-Ring O-Ring	Anillo-O Joint torique	22,0 x 1,6	
42	0095009	1	Steering part Steuerteil	Elemento de mando Régulateur		
43	0095018	1	Hose Leitung	Manguera Tuyau	160	
44	0216517	1	Fuel hose Kraftstoffleitung	Manguera de combustible Tuyau à essence	4,5x135	
45	0207586	5	Clamp Schlauchklemme	Abrazadera Collier de serrage		
46	0047977	1	Hose fitting Ventil	Unión Raccord		
47	0217101	1	Fuel hose Kraftstoffleitung	Manguera de combustible Tuyau à essence	4,5 x 170	
48	0099417	1	Tee-fitting T-Stück	Unión forma T Raccord "T"		

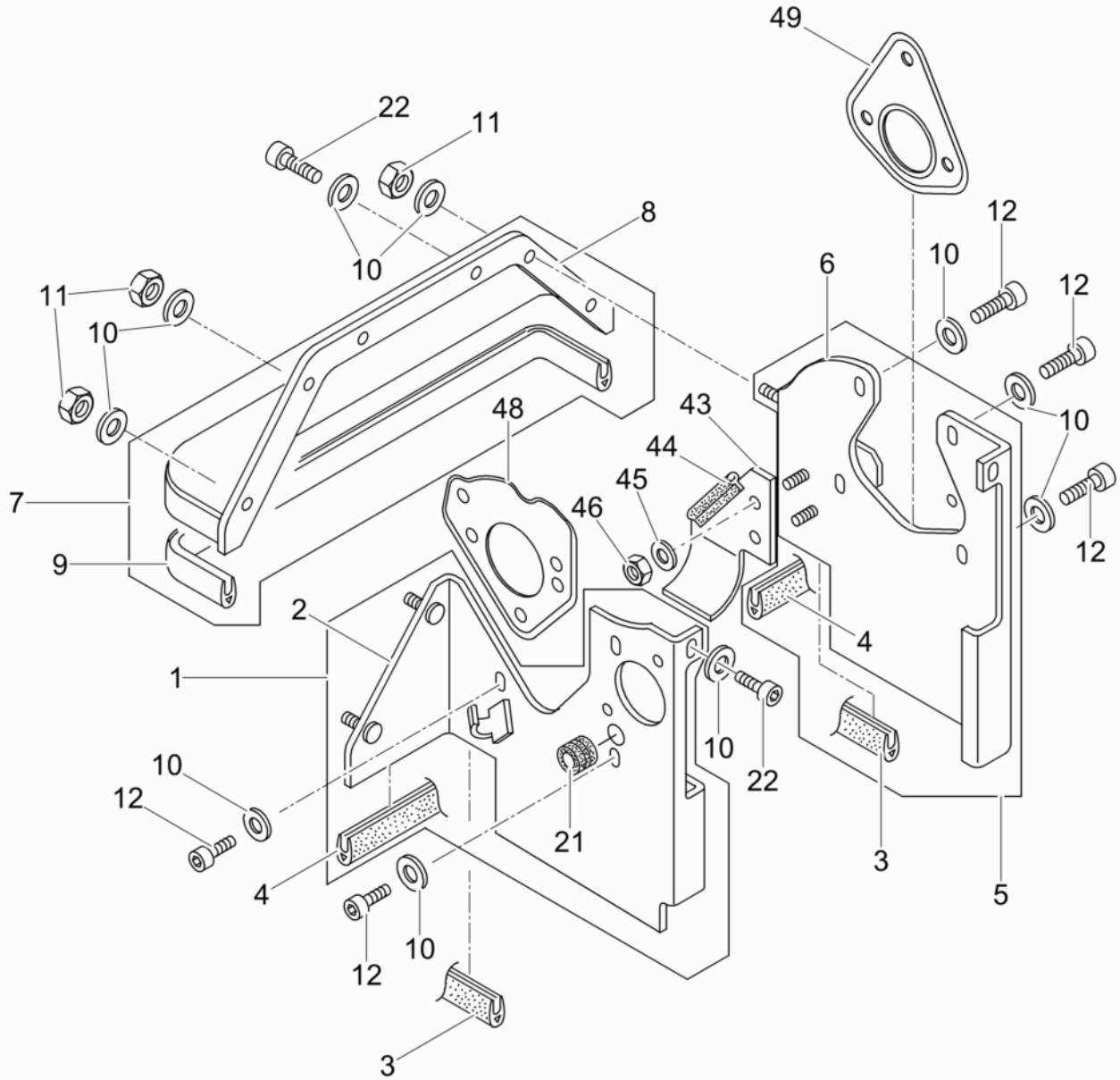

Ref. Pos.	Part No. Artikel Nr.	Qty. St.	Description Beschreibung	Descripción Description	Measurement/Abm.	Norm
					Torque/Drehm.	Sealant Schmierstoff
1	0098460	1	Left cover Verkleidung links	Tapa-izquierda Couvercle-gauche		
3	0105050	2	Profiled joint Dichtungsprofil	Junta Joint d'étanchéité profilé		
4	0105051	2	Profiled joint Dichtungsprofil	Junta Joint d'étanchéité profilé		
5	0207579	1	Baffle Luftleitblech	Deflector Déflecteur		
7	0095035	1	Cover Verkleidung	Tapa Couvercle		
9	0095036	1	Seal Dichtungsprofil	Empaque Joint		
10	0207593	15	Spring washer Spannscheibe	Arandela elástica Disque de serrage		
11	0151323	4	Locknut Sechskantmutter	Contratuercas Contre-écrou	M6	ISO4032
12	0151370	7	Cheese head screw Zylinderschraube	Tornillo cilíndrico Vis à tête cylindrique	M6 x 12	ISO4762
21	0107379	1	Grommet Gummitülle	Ojal Passe-fil		
22	0201380	4	Cheese head screw Zylinderschraube	Tornillo cilíndrico Vis à tête cylindrique	M6 x 16	
43	0207581	1	Baffle Luftleitblech	Deflector Déflecteur		
44	0207540	1	Seal Dichtleiste	Empaque Joint		
45	0151540	2	Washer Scheibe	Arandela Rondelle	A6,4	DIN9021
46	0129021	2	Locknut Sechskantmutter	Contratuercas Contre-écrou	VM6	
48	0207554	1	Gasket Dichtung	Junta Joint		
49	0217098	1	Gasket Dichtung	Junta de estanqueidad Garniture		

Breather - Governor
Entlüftung-Drehzahlverstellung

DPU 6555Hs

Purgado - Regulador de Revoluciones
Raccord Fileté de Purge -

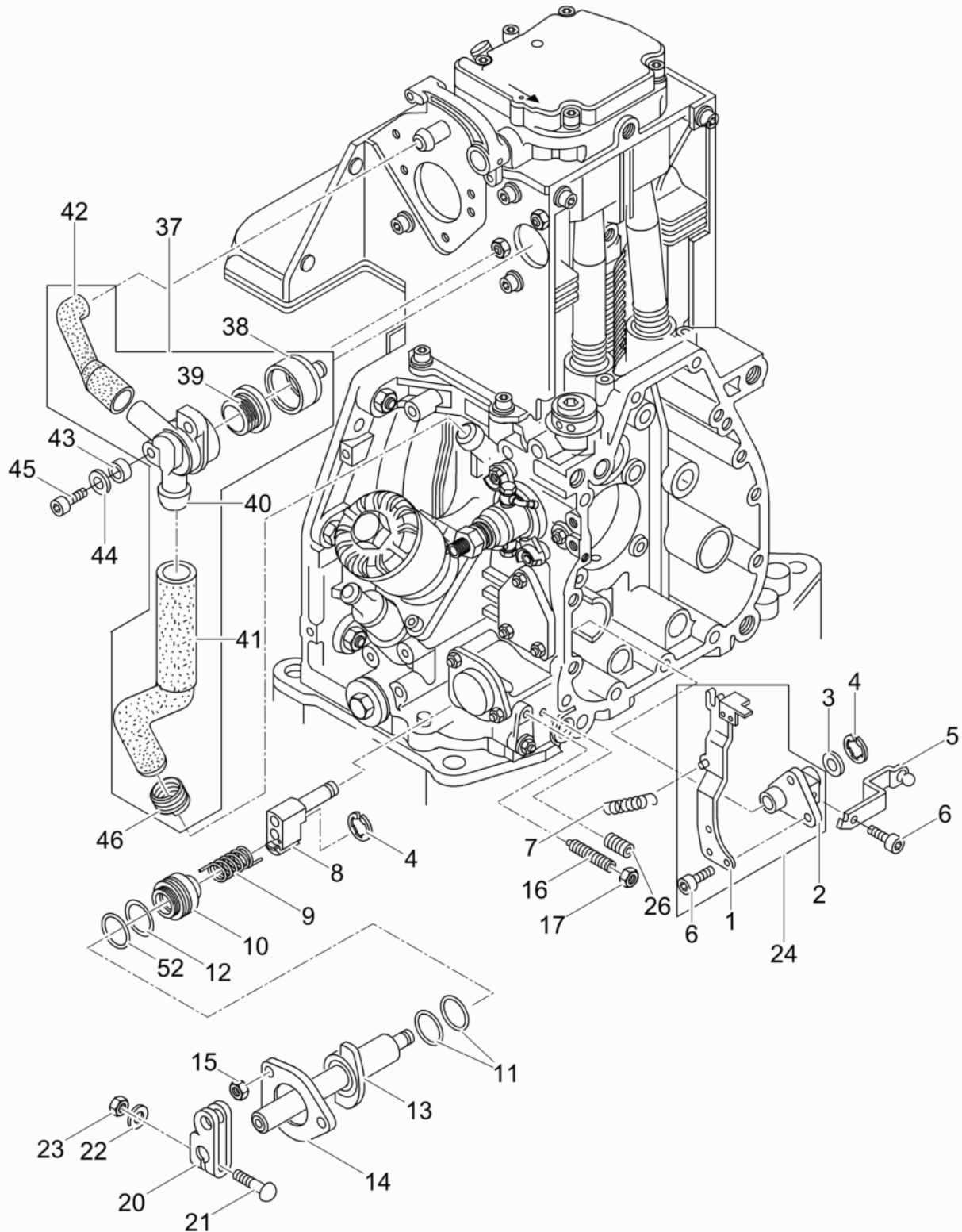

Ref. Pos.	Part No. Artikel Nr.	Qty. St.	Description Beschreibung	Descripción Description	Measurem./Abm.	Norm
					Torque/Drehm.	Sealant Schmierstoff
3	0094970	1	Washer Scheibe	Arandela Rondelle		
4	0202444	2	Lock washer Sicherungsscheibe	Arandela de Seguridad Rondelle d'arrêt	6,0	
5	0094969	1	Governor lever Reglerhebel	Palanca de regulador Levier régulateur		
6	0202449	4	Hexagon socket head screw Innensechskantschraube	Tornillo a seis lados huecos Vis à six pans creux	M5 x 8	
7	0094966	1	Spring Feder	Resorte Ressort		
8	0097417	1	Guide Führung	Guía Guide		
9	0097416	1	Torsion spring Torsionsfeder	Resorte Ressort		
10	0202395	1	Distance ring Abstandring	Anillo distanciador Bague intermediaire		
11	0202459	2	O-Ring O-Ring	Anillo-O Joint torique	18 x 2	
12	0094963	1	O-Ring O-Ring	Anillo-O Joint torique		
13	0202371	1	Shaft Welle	Eje Arbre		
14	0103080	1	Flange Flansch	Brida Bride		
15	0129021	3	Locknut Sechskantmutter	Contratuerca Contre-écrou	VM6	
16	0126909	2	Threaded pin Gewindestift	Varilla roscada Goupille fileté		
17	0151223	1	Clamp Schlauchklemme	Abrazadera Collier de serrage		
20	0104407	1	Lever Hebel	Palanca Levier		
21	0094960	1	Screw Halbrundschrabe	Tornillo Vis		
22	0151324	1	Washer Scheibe	Arandela Rondelle	6.4	
23	0207588	1	Locknut Sechskantmutter	Contratuerca Contre-écrou	M6	
24	0126519	1	Governor lever cpl. Reglerhebel kpl.	Palanca de regulador cpl. Levier régulateur cpl.		
26	0202456	1	Threaded pin Gewindestift	Varilla roscada Goupille fileté	M8 x 20	
37	0207561	1	Bleeder Valve Entlüftungsventil	Válvula Prugadora Soupape de purge de l'air		
38	0098461	1	Cap Kappe	Tapa Couvercle		
39	0094884	1	Diaphragm Membrane	Diafragma Diaphragme		
41	0098463	1	Hose Schlauch	Manguera Tuyau		

Breather - Governor
Entlüftung-Drehzahlverstellung

DPU 6555Hs

Purgado - Regulador de Revoluciones
Raccord Fileté de Purge -

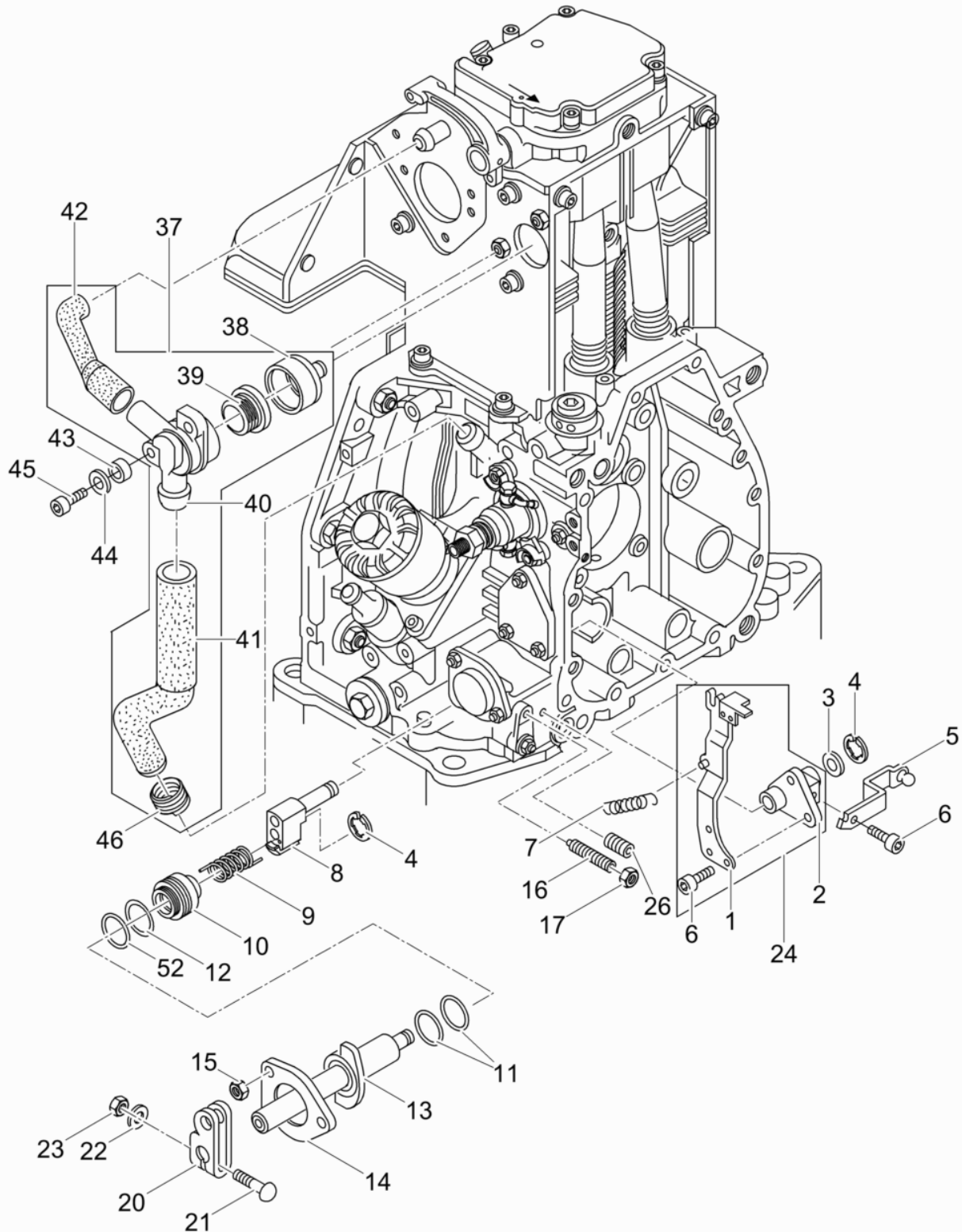

Ref. Pos.	Part No. Artikel Nr.	Qty. St.	Description Beschreibung	Descripción Description	Measurem./Abm.	Norm
					Torque/Drehm.	Sealant Schmierstoff
42	0098462	1	Breather tube Entlüftungsschlauch	Línea de purgado Tuyau d'évacuation purge		
43	0098465	2	Bushing Buchse	Buje Douille		
44	0151290	2	Spring washer Federscheibe	Arandela elástica Rondelle à ressort	A6	DIN137
45	0151231	2	Cheese head screw Zylinderschraube	Tornillo cilíndrico Vis à tête cylindrique	M6 x 16	ISO4762
46	0102470	1	Clip Federklemme	Borne de contacto elástico Pince de ressort		
52	0202466	1	Ring Ring	Anillo Bague	32 x 45 x 2.5	

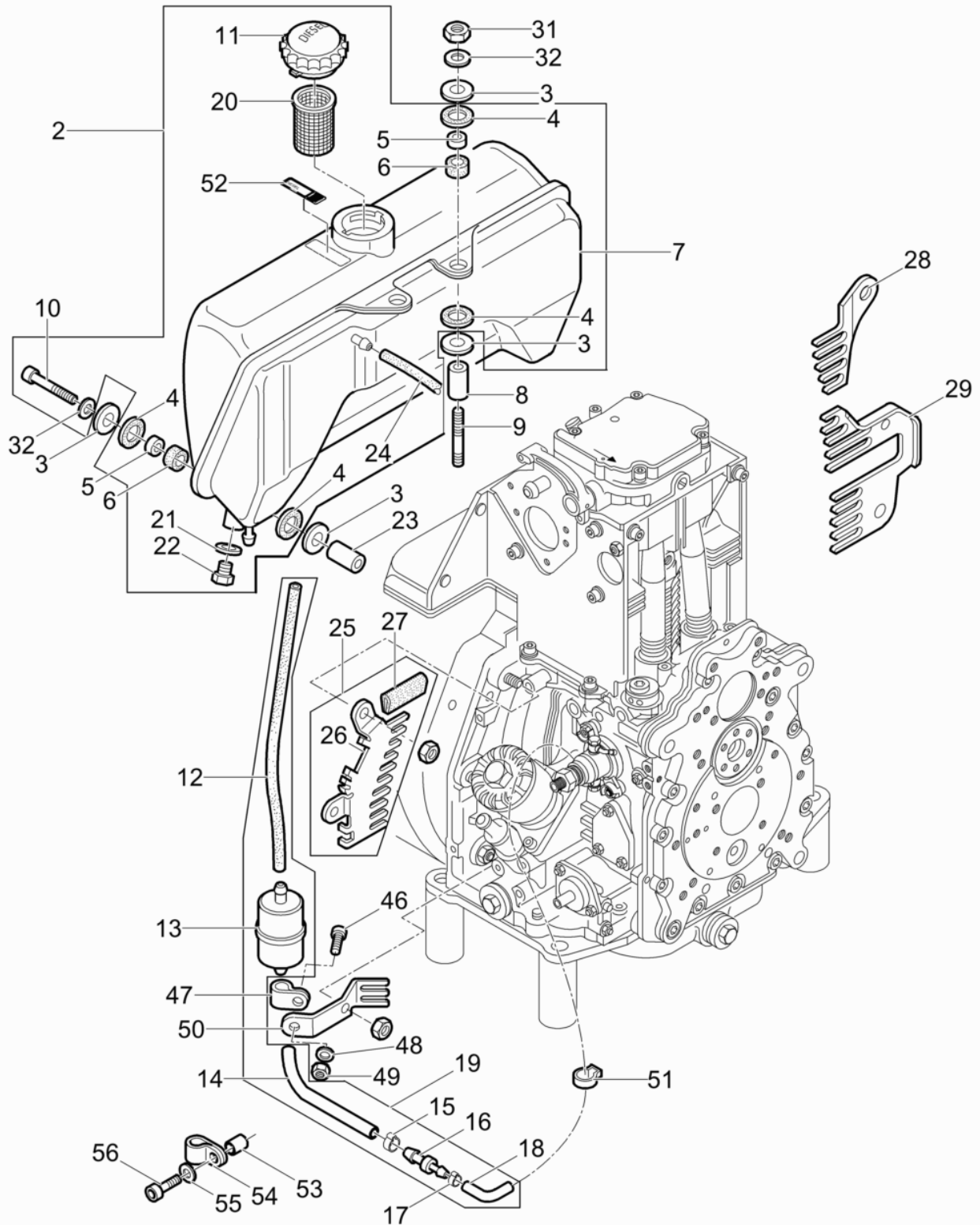

Ref. Pos.	Part No. Artikel Nr.	Qty. St.	Description Beschreibung	Descripción Description	Measurement./Abm.	Norm
					Torque/Drehm.	Sealant Schmierstoff
2	0095081	1	Fuel tank Kraftstofftank	Tanque de combustible Réservoir de carburant		
3	0151344	12	Washer Scheibe	Arandela Rondelle		
4	0095355	12	Washer Gummischeibe	Arandela Rondelle		
5	0095356	6	Bushing Buchse	Buje Douille		
6	0095357	6	Sleeve Gummihülse	Manguito Douille		
8	0095082	2	Bushing Buchse	Buje Douille		
9	0031063	2	Stud bolt Stiftschraube	Tornillo espárrago Goupille fileté	M8 x 75	DIN835
10	0207613	4	Cheese head screw Zylinderschraube	Tornillo cilíndrico Vis à tête cylindrique	M8 x 40	
11	0099523	1	Cap Tankverschluss	Tapa Couvercle	60	
12	0207576	1	Fuel Pipe Kraftstoffleitung	Tubería de Combustible Tuyau à Combustible	7 x 220in	
13	0022832	1	Fuel filter Kraftstofffilter	Filtro de combustible Filtre à carburant		
14	0207577	1	Fuel Pipe Kraftstoffleitung	Tubería de Combustible Tuyau à Combustible	7 x 250in	
15	0203655	1	Clamp Schlauchklemme	Abrazadera Collier de serrage	16,00	
16	0207583	1	Nipple Nippel	Boquilla roscada Raccord fileté		
17	0207586	1	Clamp Schlauchklemme	Abrazadera Collier de serrage		
18	0207519	1	Fuel Pipe Kraftstoffleitung	Tubería de Combustible Tuyau à Combustible	5 x 75in	
19	0207578	1	Filter-fuel cpl. Kraftstofffilter kpl.	Filtro de combustible compl.bustible Filtre à carburant compl.		
20	0095358	1	Fuel strainer Sieb	Tamizador Filtre-tamis à carburant	50	
21	0104763	1	Washer Scheibe	Arandela Rondelle		
22	0202413	1	Screw Locking Schraubverschluss	Cierre Roscada Fermeture de Vissage		
23	0099786	4	Bushing Buchse	Buje Douille		
24	0207574	1	Fuel Pipe Kraftstoffleitung	Tubería de Combustible Tuyau à Combustible	5 x 50in	
25	0207536	1	Contact safety device Berührungsschutz	Dispositivo de protección Grille de protection		
27	0104421	1	Profiled joint Dichtungsprofil	Junta Joint d'étanchéité profilé	29	
28	0107491	1	Covering Abdeckung	Cubierta Couverture		

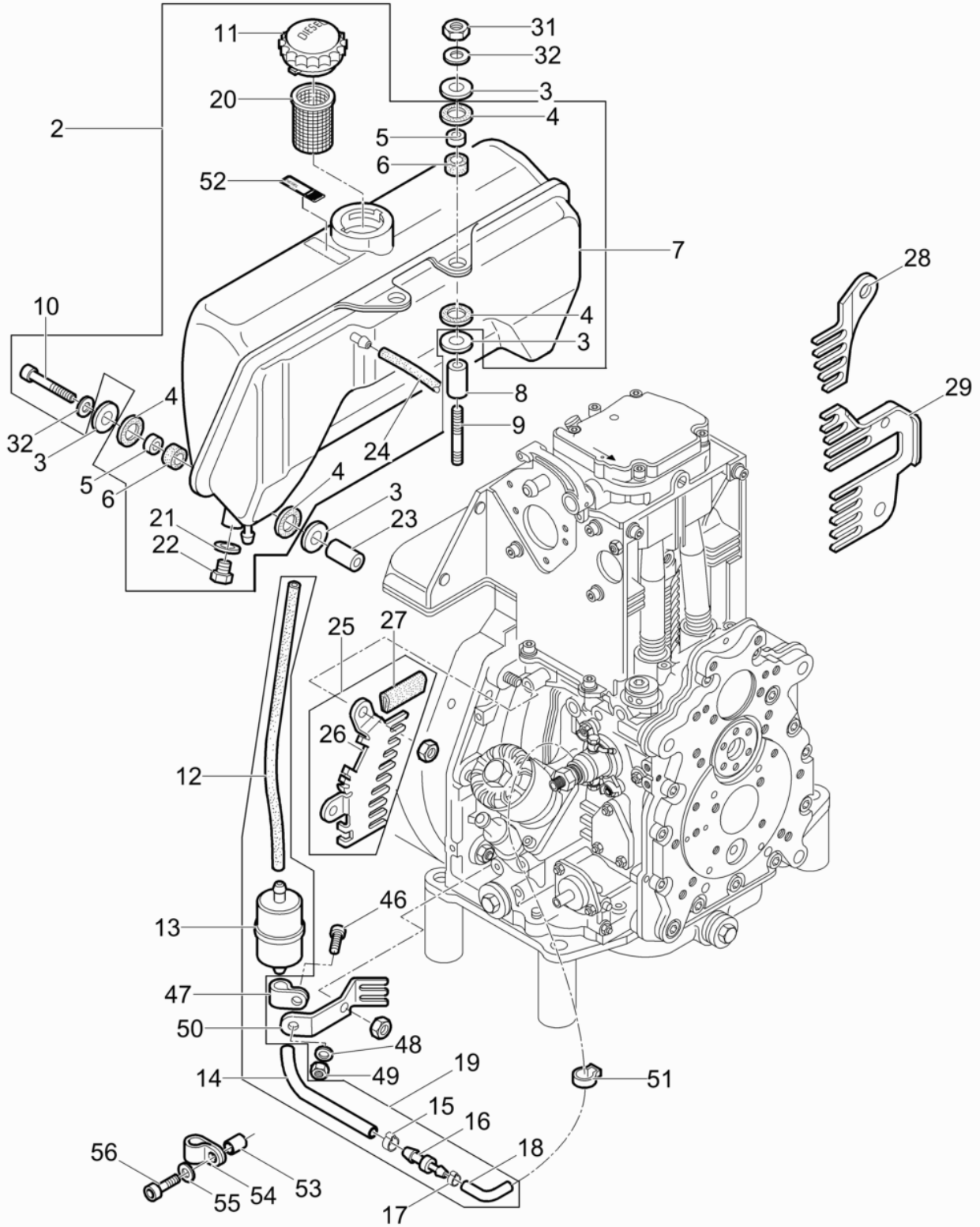

Ref. Pos.	Part No. Artikel Nr.	Qty. St.	Description Beschreibung	Descripción Description	Measurem./Abm.	Norm
					Torque/Drehm.	Sealant Schmierstoff
29	0107492	1	Covering Abdeckung	Cubierta Couverture		
31	0151379	2	Locknut Sechskantmutter	Contratuerca Contre-écrou	M8	ISO4032
32	0151218	6	Lock washer Federring	Arandela elástica Rondelle de ressort	8	
46	0151231	1	Cheese head screw Zylinderschraube	Tornillo cilíndrico Vis à tête cylindrique	M6 x 16	ISO4762
47	0107451	2	Clamp Schelle	Abrazadera Agrafe		
48	0151234	1	Stub shaft Wellenstummel	Muñón Bout d'arbre		
49	0151323	1	Locknut Sechskantmutter	Contratuerca Contre-écrou	M6	ISO4032
50	0207537	1	Contact safety device Berührungsschutz	Dispositivo de protección Grille de protection		
51	0207586	1	Clamp Schlauchklemme	Abrazadera Collier de serrage		
52	0129791	1	Decal-Diesel Aufkleber-Diesel	Calcomanía-Diesel Autocollant-Diesel		
53	0207522	1	Spacer Distanzbüchse	Caja distanciador Douille d'écartement		
54	0107451	1	Clamp Schelle	Abrazadera Agrafe		
55	0151456	1	Lock washer Federring	Arandela elástica Rondelle de ressort	6	DIN128
56	0129010	1	Cheese head screw Zylinderschraube	Tornillo cilíndrico Vis à tête cylindrique	M6 x 25	DIN912

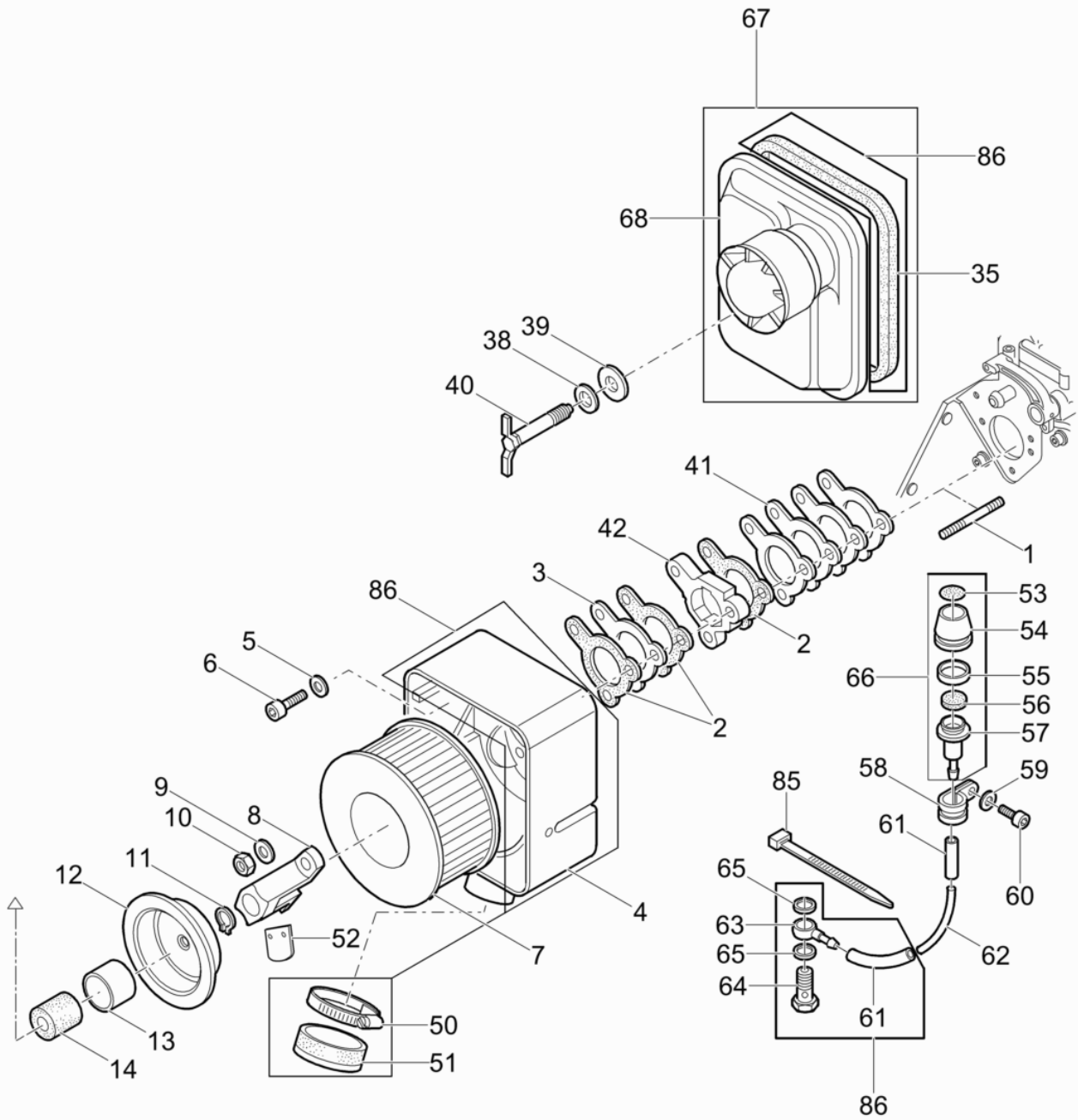

Ref. Pos.	Part No. Artikel Nr.	Qty. St.	Description Beschreibung	Descripción Description	Measurement/Abm.	Norm
					Torque/Drehm.	Sealant Schmierstoff
1	0207815	2	Stud Stiftschraube	Perno prisionero Boulon	M8 x 60	
2	0095088	3	Seal Dichtung	Empaque Joint		
3	0095089	1	Flange Isolierflansch	Brida Collerette		
5	0013601	1	Spring washer Federscheibe	Arandela elástica Rondelle à ressort	A8	DIN137
6	0207614	1	Cheese head screw Zylinderschraube	Tornillo cilíndrico Vis à tête cylindrique	M8 x 45	
7	0095091	1	Air cleaner element Luftfilter	Elemento-filtro Élément filtrant		
8	0099793	1	Holder Halter	Soporte Attache		
9	0151553	2	Washer Scheibe	Arandela Rondelle	B8,4	ISO7089
10	0129516	2	Nut Mutter	Tuerca Ecrou	M8	
12	510002774	1	Filter Cover cpl. Filterdeckel kpl.	tapa de filtro cpl. Couvercle de Filtre cpl.		
35	0097831	1	Seal Dichtung	Empaque Joint		
40	0108907	1	Wing nut Flügelmutter	Tuerca mariposa Ecrou papillon	M6	
41	0097840	1	Set-gaskets Dichtungssatz	Juego de juntas Jeu de joints		
42	0097833	1	Intermediate flange Zwischenflansch	Brida intermedia Bride intermediaire		
50	0099804	1	Clamp Schelle	Abrazadera Collier		
51	0099803	1	Cap Abdeckkappe	Tapa protectora Chape de protection		
52	0099792	1	Valve plate Ventilplatte	Placa de válvula Plaque de soupape		
53	0104463	1	Information sign Hinweisschild	Placa indicadora Plaque		
54	0099808	1	Rubber cap Gummikappe	Capuchón de goma Chape de caoutchouc		
55	0104462	1	Rubber ring Gummiring	Anillo de goma Bague en caoutchouc		
56	0109714	1	Filter disk Filterscheibe	Disco filtrante Rondelle de filtre		
57	0099949	1	Adaptor Adapter	Adaptador Adaptateur		
58	0095050	1	Pipe clamp Rohrschelle	Abrazadera Collier pour tuyau		
59	0151456	1	Lock washer Federring	Arandela elástica Rondelle de ressort	6	DIN128
60	0202437	1	Cheese head screw Zylinderschraube	Tornillo cilíndrico Vis à tête cylindrique	M6 x 20	

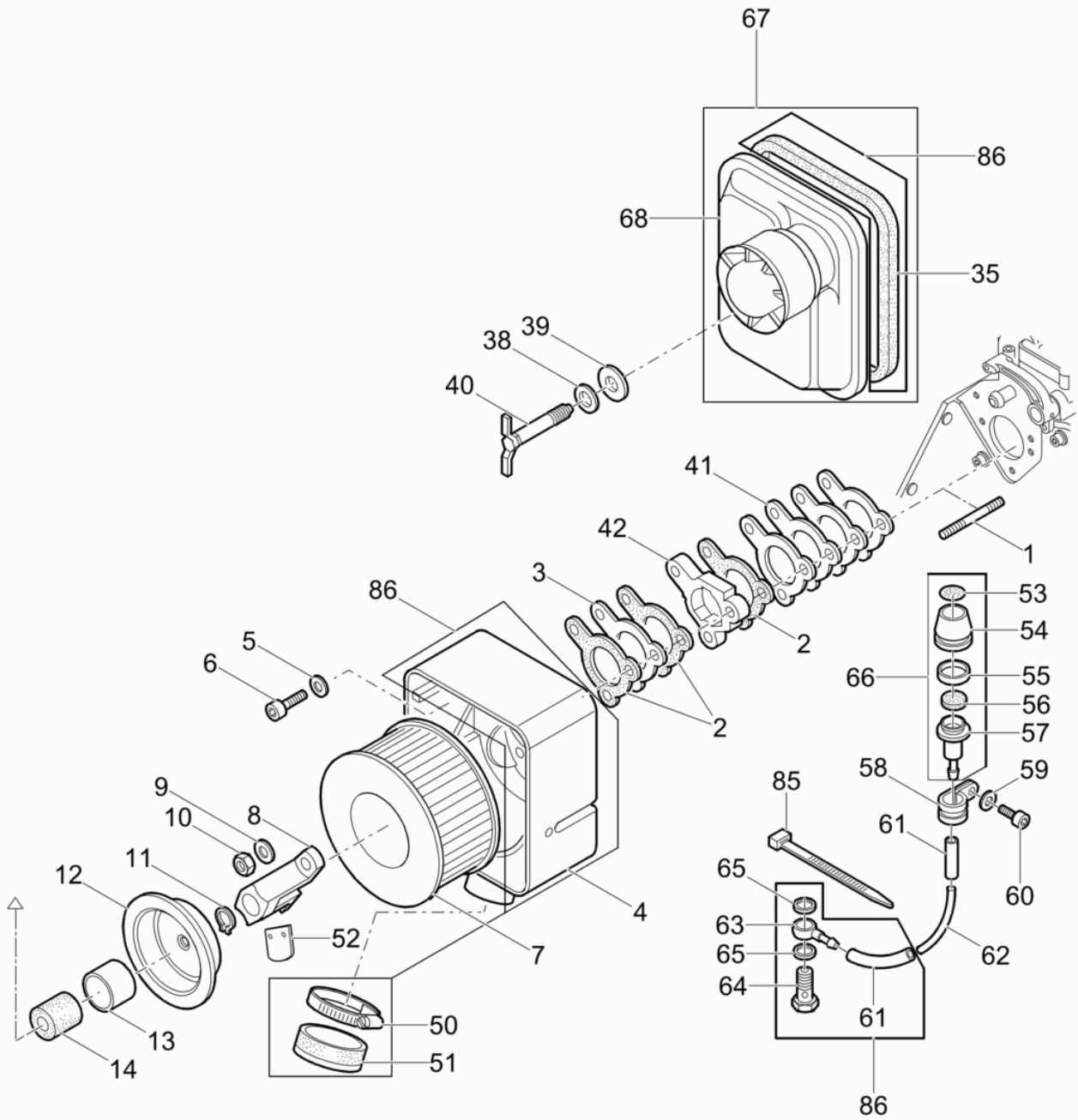

Ref. Pos.	Part No. Artikel Nr.	Qty. St.	Description Beschreibung	Descripción Description	Measurem./Abm.	Norm
					Torque/Drehm.	Sealant Schmierstoff
61	0217108	2	Fuel hose Kraftstoffleitung	Manguera de combustible Tuyau à essence	3,5 x 50	
62	0099807	1	Hose piece Schlauchstück	Tramo de manguera Pièce de tuyau		
63	0099805	1	Nipple Nippel	Boquilla roscada Nipple		
64	0207566	1	Banjo bolt Hohlschraube	Perno hueco Boulon creux à filet femelle		
65	0071121	2	Sealing ring Dichtungsring	Anillo sellante Bague d'étanchéité	A10 x 13,5	
66	0109711	1	Maintenance indicator cpl. Wartungsanzeige kpl.	Indicador de mantenimiento Indicateur dentretien		
67	5100002777	1	Cover with cyclone Deckel mit Zyklon	Tapa con ciclón Couvercle avec cyclone		
85	0109710	1	Tie cable Kabelbinder	Fijación Attache		
86	0097829	1	Housing Gehäuse	Carcasa Carter		

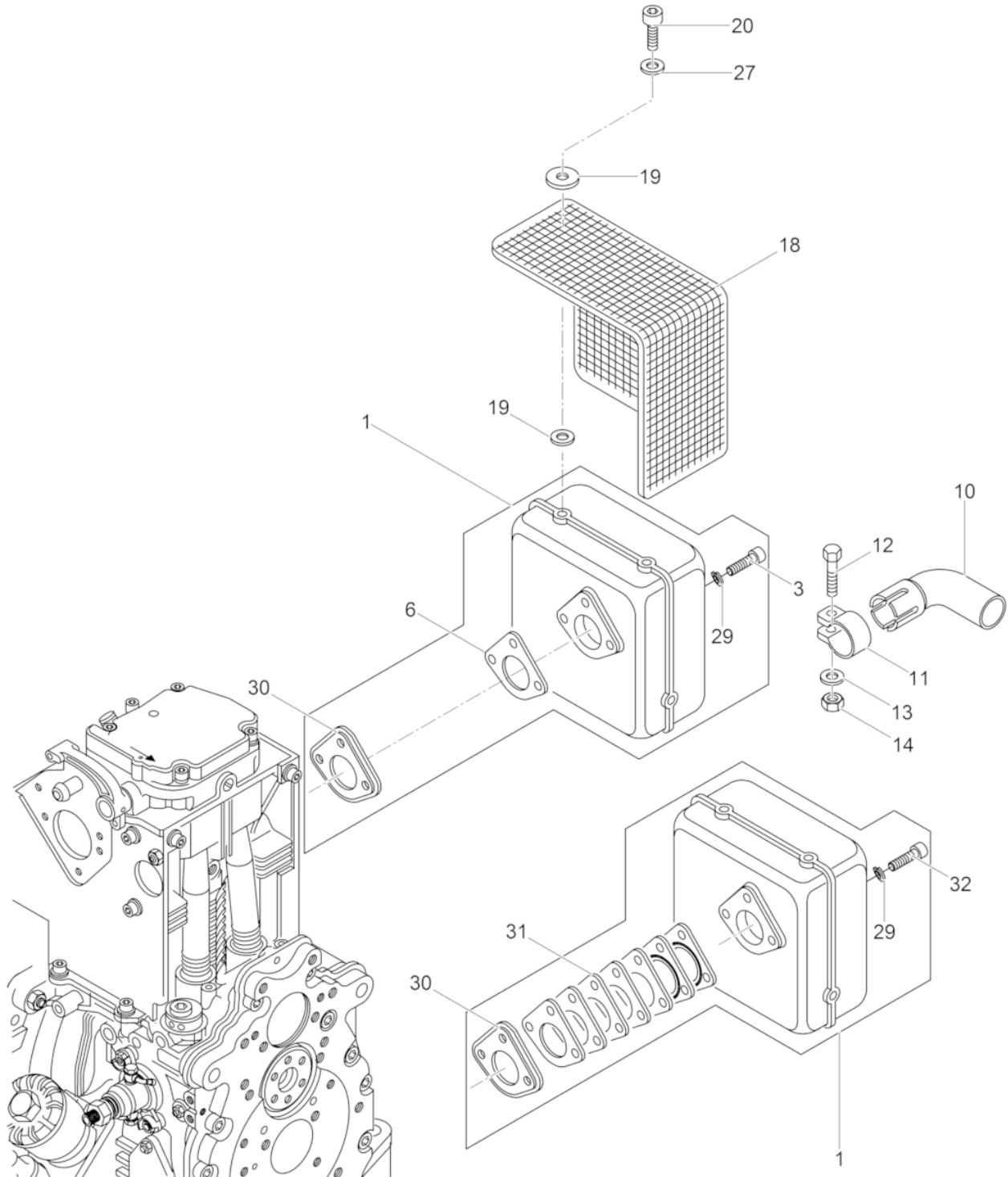

Ref. Pos.	Part No. Artikel Nr.	Qty. St.	Description Beschreibung	Descripción Description	Measurement./Abm.	Norm
					Torque/Drehm.	Sealant Schmierstoff
1	0217088	1	Exhaust Auspuff	Escape Échappement		
3	0151578	3	Cheese head screw Zylinderschraube	Tornillo cilíndrico Vis à tête cylindrique	M8 x 30	ISO4762
6	5100001033	1	Gasket Dichtung	Junta Joint		
10	0126956	1	Exhaust pipe Abgasrohr	Tubo de escape Tubulare d'evacuation		
11	0095100	1	Clamp Schelle	Abrazadera Collier		
12	0207591	1	Hexagonal head cap screw Sechskantschraube	Tornillo hexagonal Vis à tête hexagonale	M10 x 50	
13	0202434	1	Washer Scheibe	Arandela Rondelle	10,5	
14	0207589	1	Locknut Sechskantmutter	Contratuercas Contre-écrou	VM10	
18	0207535	1	Contact safety device Berührungsschutz	Dispositivo de protección Grille de protection		
19	0099525	10	Washer Scheibe	Arandela Rondelle		
20	0202443	5	Cheese head screw Zylinderschraube	Tornillo cilíndrico Vis à tête cylindrique	M6 x 20	
27	0151540	5	Washer Scheibe	Arandela Rondelle	A6,4	DIN9021
29	0151218	3	Lock washer Federring	Arandela elástica Rondelle de ressort	8	
30	0217098	1	Gasket Dichtung	Junta de estanqueidadndro Garniture		
31	0217096	1	Gasket set Dichtungssatz	Juego de juntas Jeu de joints		
32	0217111	3	Cheese head screw Zylinderschraube	Tornillo cilíndrico Vis à tête cylindrique	M8 x 35	

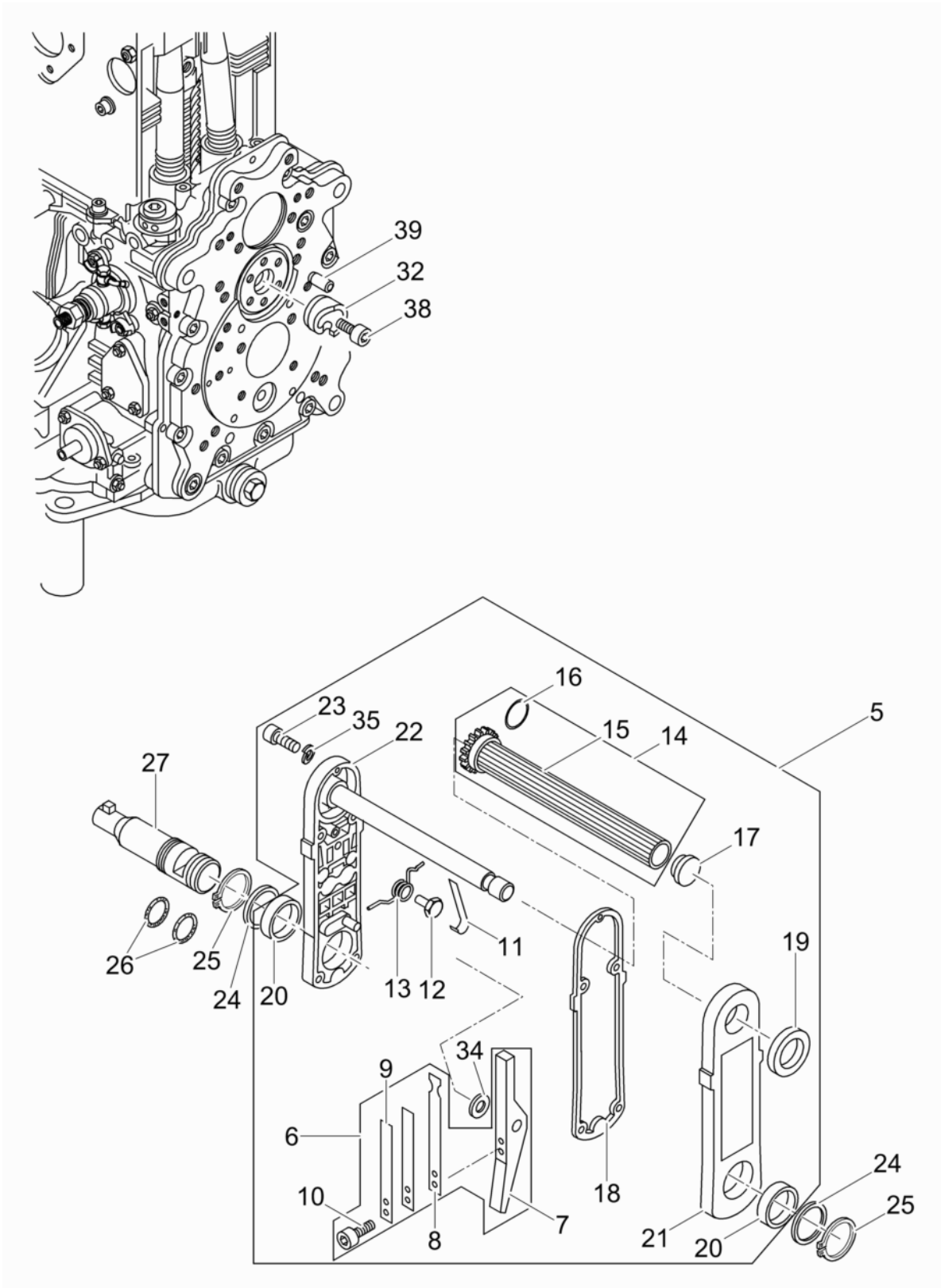

Ref. Pos.	Part No. Artikel Nr.	Qty. St.	Description Beschreibung	Descripción Description	Measurem./Abm.	Norm
					Torque/Drehm.	Sealant Schmierstoff
5	0210280	1	Starting Crank Kurbel	Manivela de Arranque Manivelle de Démarrage		
6	0064064	1	Lever Hebel	Palanca Levier		
8	0066157	1	Leaf spring Blattfeder	Resorte de láminas Ressort à lames		
9	0066158	2	Leaf spring Blattfeder	Resorte de láminas Ressort à lames		
10	0049190	2	Cheese head screw Zylinderschraube	Tornillo cilíndrico Vis à tête cylindrique	M5 x 8 10Nm/7ft.lbs	ISO4762
11	0069547	1	Leaf spring Blattfeder	Resorte de láminas Ressort à lames		
12	0069548	1	Screw Schraube	Tornillo Vis		
13	0069549	1	Leg spring Schenkelfeder	Resorte de brazo Ressort coude		
14	0069545	1	Tubular handle Griffrohr	Empuñadura Poignée tubulaire		
16	0105765	1	O-ring O-Ring	Anillo-O Bague-O		
17	0064062	1	Plug Stopfen	Tapón Bouchon		
18	0064068	1	Seal Dichtung	Junta Joint		
19	0064063	1	Rotary shaft seal Wellendichtring	Anillo de retén radial Bague d'étanchéité	28 x 35 x 4	
20	0066156	2	Bush Buchse	Buje Boîte		
23	0203133	5	Hexagon socket head screw Innensechskantschraube	Tornillo a seis lados huecos Vis à six pans creux	M6 x 25	
24	0069546	2	Shim ring Passscheibe	Arandela de ajuste Disque dajustage	30 x 38 x 0,15	DIN988
25	0202441	2	Clip-retaining Halteclip	Presilla de retención Clé de serrage	A30x1.5	
26	0064067	2	O-Ring O-Ring	Anillo-O Joint torique	26 x 1,5	
27	0107494	1	Starting shaft Andrehwelle	Garra de arranque Arbre de mise en marche		
32	0097419	1	Starting jaw Andrehklaue	Garra de arranque Griffe de mise en marche		
34	0064065	1	Shim Ring Passscheibe	Arandela de Ajuste Disque D'Ajustage	10 x 16 x 1	DIN988
35	0151456	5	Lock washer Federring	Arandela elástica Rondelle de ressort	6	DIN128
38	0201372	1	Hexagon socket head screw Innensechskantschraube	Tornillo a seis lados huecos Vis à six pans creux	M8x12	
39	0202453	1	Straight pin Zylinderstift	Pasador cilíndrico Goupille cylindrique		

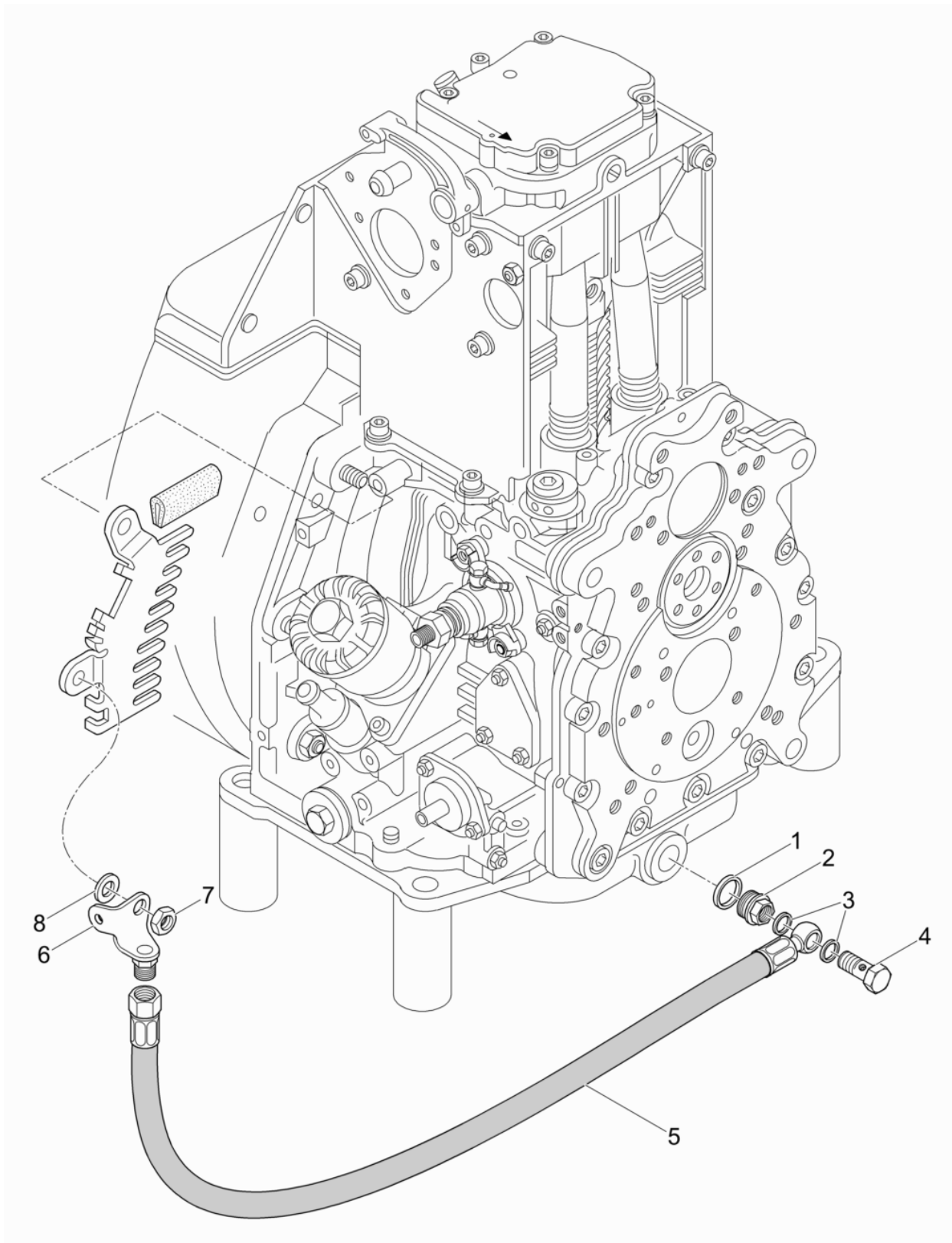

Ref. Pos.	Part No. Artikel Nr.	Qty. St.	Description Beschreibung	Descripción Description	Measurement./Abm.	Norm
					Torque/Drehm.	Sealant Schmierstoff
1	0202416	1	Oil Seal Öldichtung	Junta de Aceite Joint D'Huile	52 x 80 x 10	
2	0104406	1	Screw plug Verschlußschraube	Tornillo de cierre Vis de fermeture		
3	0012624	2	Gasket Dichtring	Anillo de junta Bague d'étanchéité	A14 x 18	DIN7603
4	0203656	1	Banjo bolt Hohlschraube	Perno hueco Boulon creux à filet femelle	10-3	
5	0217092	1	Hose pipe Oil drain Schlauchleitung m. Ölablass	Conducto flexible Drenaje de aceite Conduite flexible Raccord		
6	0126074	1	Retainer Halter	Soporte Logement		
7	0207530	1	Locknut Sechskantmutter	Contratuercas Contre-écrou	M12	
8	0203132	1	Washer Scheibe	Arandela Rondelle	A13	

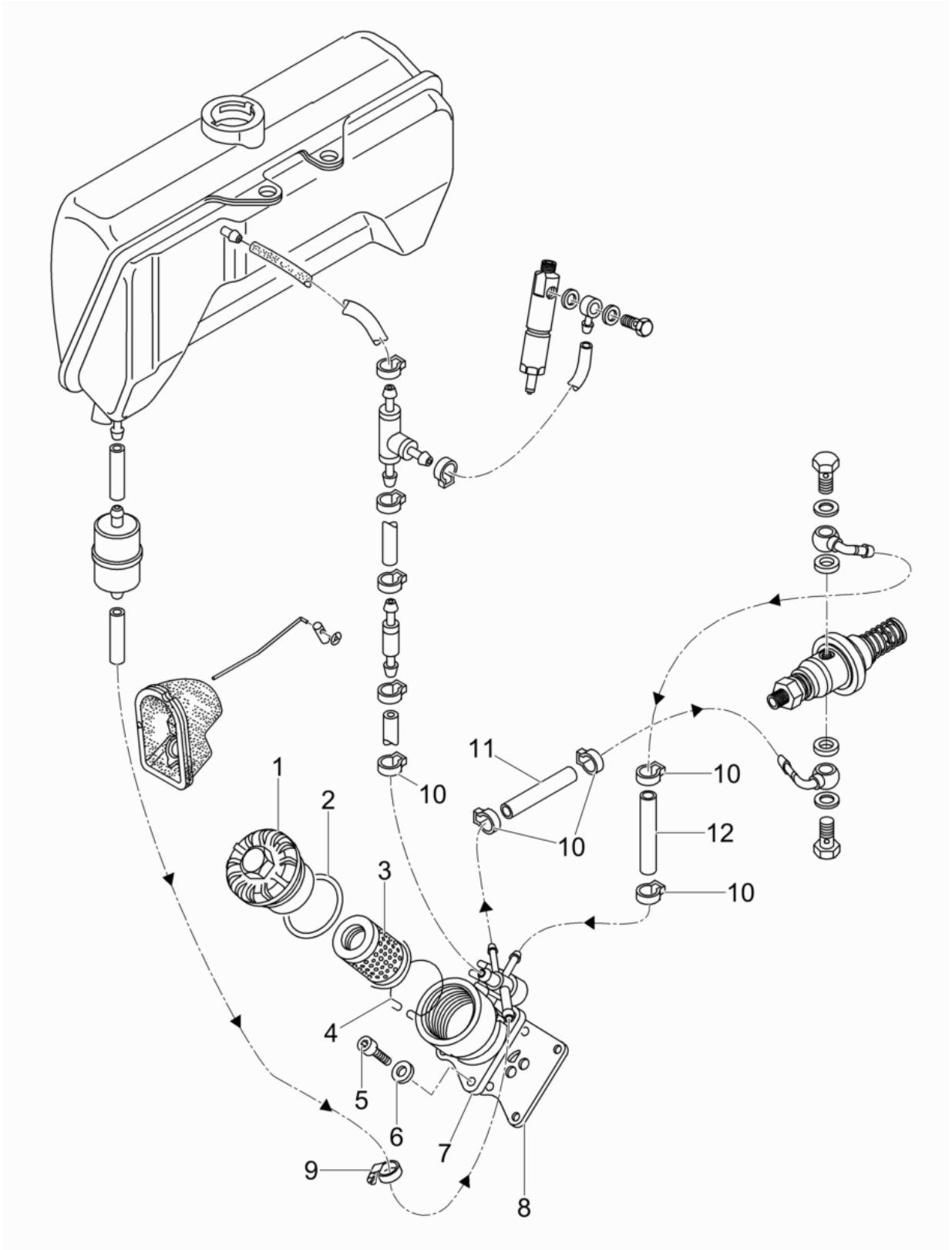

Ref. Pos.	Part No. Artikel Nr.	Qty. St.	Description Beschreibung	Descripción Description	Measurem./Abm.	Norm
					Torque/Drehm.	Sealant Schmierstoff
1	0094931	1	Cover Schraubdeckel	Tapa Couvercle		
2	0094928	1	Gasket Flachdichtring	Juntaaceite Joint		
3	0094930	1	Element Filterpatrone	Elemento Elément		
4	0104402	1	Spring Drahtfeder	Resorte Ressort		
5	0202437	4	Cheese head screw Zylinderschraube	Tornillo cilíndrico Vis à tête cylindrique	M6 x 20	
6	0151290	4	Spring washer Federscheibe	Arandela elástica Rondelle à ressort	A6	DIN137
7	0207531	1	Valve Absperrventil	Válvula de desconexión Soupape		
8	0106559	1	Seal Dichtung	Junta Joint		
9	0202469	1	Clamp Schlauchschelle	Abrazadera Agrafe		
10	0207586	5	Clamp Schlauchklemme	Abrazadera Collier de serrage		
11	0217102	1	Fuel hose Kraftstoffleitung	Manguera de combustible Tuyau à essence	4,5 x 200	
12	0217107	1	Fuel hose Kraftstoffleitung	Manguera de combustible Tuyau à essence	4,5 x 110	
17	0207810	1	T-piece T-Stück	Pieza T T-pièce		
18	0207586	7	Clamp Schlauchklemme	Abrazadera Collier de serrage		
19	0217104	1	Fuel hose Kraftstoffleitung	Manguera de combustible Tuyau à essence	4,5 x 30	
20	0207526	1	Valve Ventil	Válvula Soupape		
21	0217109	1	Fuel hose Kraftstoffleitung	Manguera de combustible Tuyau à essence	5,3 x 50	
22	0217093	1	Back pressure valve Rückschlagventil	Válvula de retención Soupape de retenue		
23	0217103	1	Fuel hose Kraftstoffleitung	Manguera de combustible Tuyau à essence	4,5 x 80	
24	0217106	1	Fuel hose Kraftstoffleitung	Manguera de combustible Tuyau à essence	4,5 x 35	
25	0106563	1	Tee-fitting T-Stück	Unión forma T Raccord "T"		
26	0217105	1	Fuel hose Kraftstoffleitung	Manguera de combustible Tuyau à essence	4,5 x 50	
27	0217095	1	Fuel pipe cpl. Kraftstoffleitung kpl.	Pipa del combustible cpl. Pipe du combustible cpl.		
28	0207525	1	Screw nipple Anschraubnippel	Boquilla roscada Raccord de vissage		

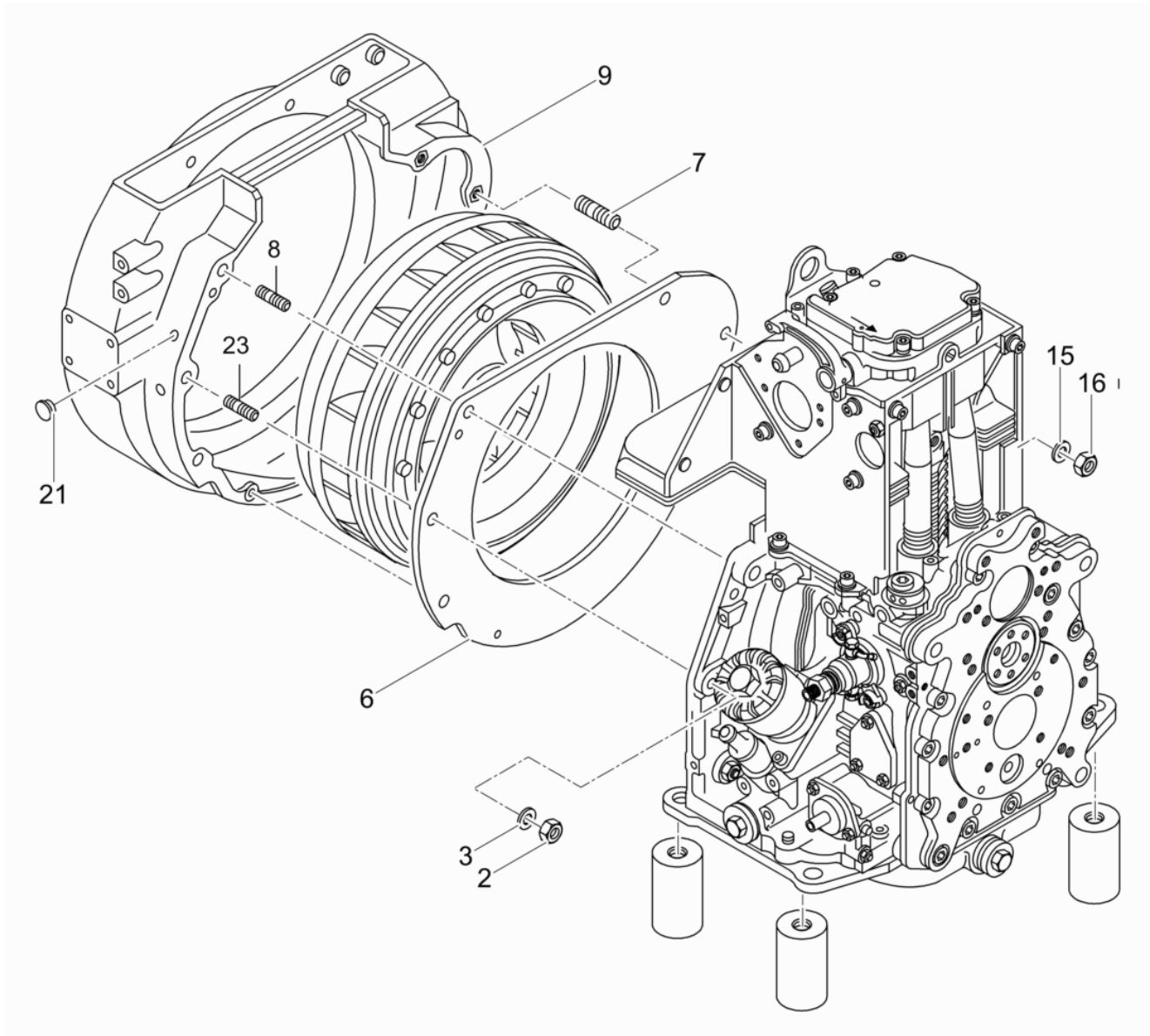

Ref. Pos.	Part No. Artikel Nr.	Qty. St.	Description Beschreibung	Descripción Description	Measurement./Abm.	Norm
					Torque/Drehm.	Sealant Schmierstoff
2	0207560	4	Injection Valve Einspritzventil	Válvula Inyectora Soupape d'Injection		
3	0203132	4	Washer Scheibe	Arandela Rondelle	A13	
4	0202338	2	Hexagonal head cap screw Sechskantschraube	Tornillo hexagonal Vis à tête hexagonale	M6 x 16	DIN933
5	0151456	2	Lock washer Federring	Arandela elástica Rondelle de ressort	6	DIN128
6	0107496	1	Baffle plate Trennblech	Placa separadora Separateur		
7	0010937	2	Stud bolt Stiftschraube	Tornillo espárrago Goupille fileté	M12 x 40	
8	0010936	3	Stud bolt Stiftschraube	Tornillo espárrago Goupille fileté	M12 x 35 86Nm/63ft.lbs	DIN835
9	0095042	1	Housing Anschlußgehäuse	Caja Carter		
15	0203132	2	Washer Scheibe	Arandela Rondelle	A13	
16	0207530	2	Locknut Sechskantmutter	Contratuerca Contre-écrou	M12	
21	0207605	2	Push-in plug Verschlußstopfen	Tapón Bouchon		
23	0010937	1	Stud bolt Stiftschraube	Tornillo espárrago Goupille fileté	M12 x 40	

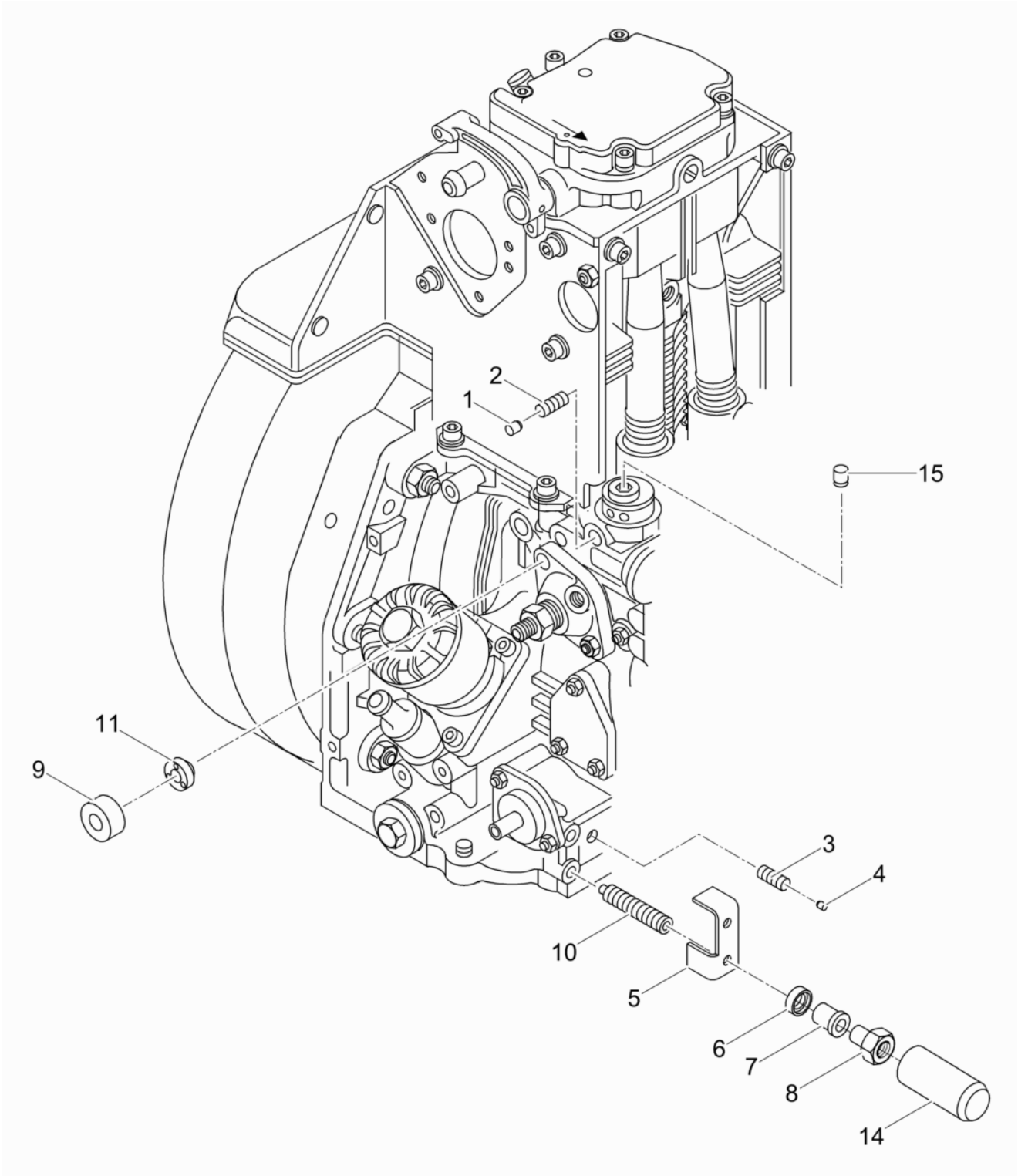

Ref. Pos.	Part No. Artikel Nr.	Qty. St.	Description Beschreibung	Descripción Description	Measurement./Abm.	Norm
					Torque/Drehm.	Sealant Schmierstoff
1	0207603	1	Push-in plug Verschlußstopfen	Tapón Bouchon		
2	0020348	1	Threaded pin Gewindestift	Varilla roscada Goupille fileté	M8 x 16	DIN916
3	0202456	1	Threaded pin Gewindestift	Varilla roscada Goupille fileté	M8 x 20	
4	0207604	1	Push-in plug Verschlußstopfen	Tapón Bouchon		
5	0126904	1	Angle Winkel	Ángulo Coude		
6	0126905	1	Washer Scheibe	Arandela Rondelle		
7	0126906	1	Bush Buchse	Buje Boîte		
8	0126907	1	Threaded bush Gewindebuchse	Casquillo roscado Boîte tarandée	M6	
9	0207567	2	Cap Kappe	Tapa Couvercle		
10	0126909	2	Threaded pin Gewindestift	Varilla roscada Goupille fileté		
11	0207587	2	Counternut Sicherheitsmutter	Tuerca de seguridad Ecrou de sécurité		
14	0126911	1	Cap Kappe	Tapa Chapeau		
15	0207602	1	Push-in plug Verschlußstopfen	Tapón Bouchon		

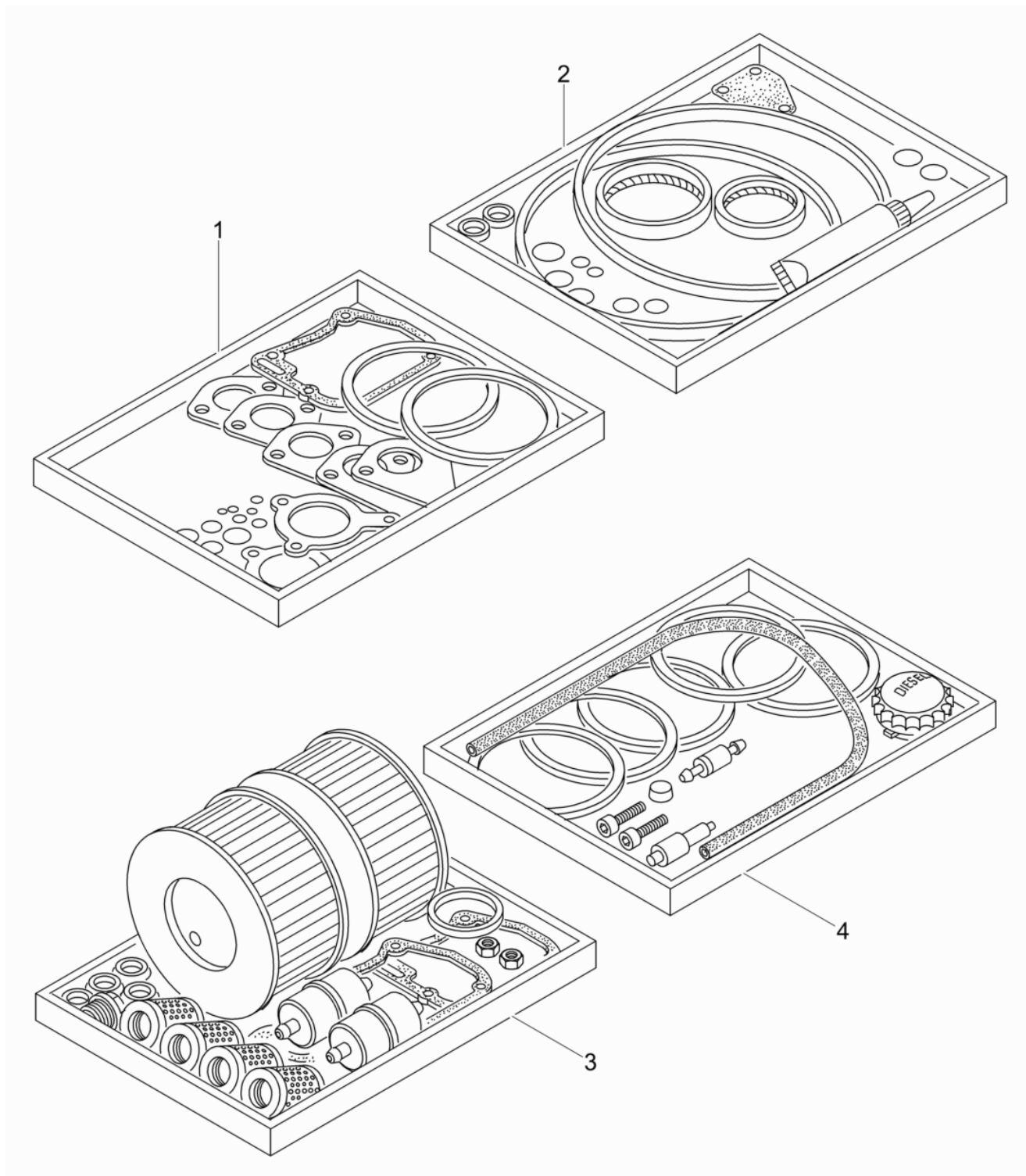

Ref. Pos.	Part No. Artikel Nr.	Qty. St.	Description Beschreibung	Descripción Description	Measurement./Abm.	Norm
					Torque/Drehm.	Sealant Schmierstoff
1	0217091	1	Set-gasket cylinder head Dichtungssatz Zylinderkopf	Juego de juntas-culata de cilindro Jeu de joints-culasse de		
2	0094878	1	Set-gasket, crankcase Dichtungssatz-Kurbelgehäuse	Juego de juntas-cárter Jeu de joints-carter		
3	0207606	1	Maintenance set Wartungssatz	Juego para mantenimiento Jeu d'entretien		
4	0217090	1	Breakdown kit Pannensatz	Sistema de la interrupción Ensemble de panne		



**WACKER
NEUSON**

**Accessoires
Zubehör
Accesorios
Accessories**

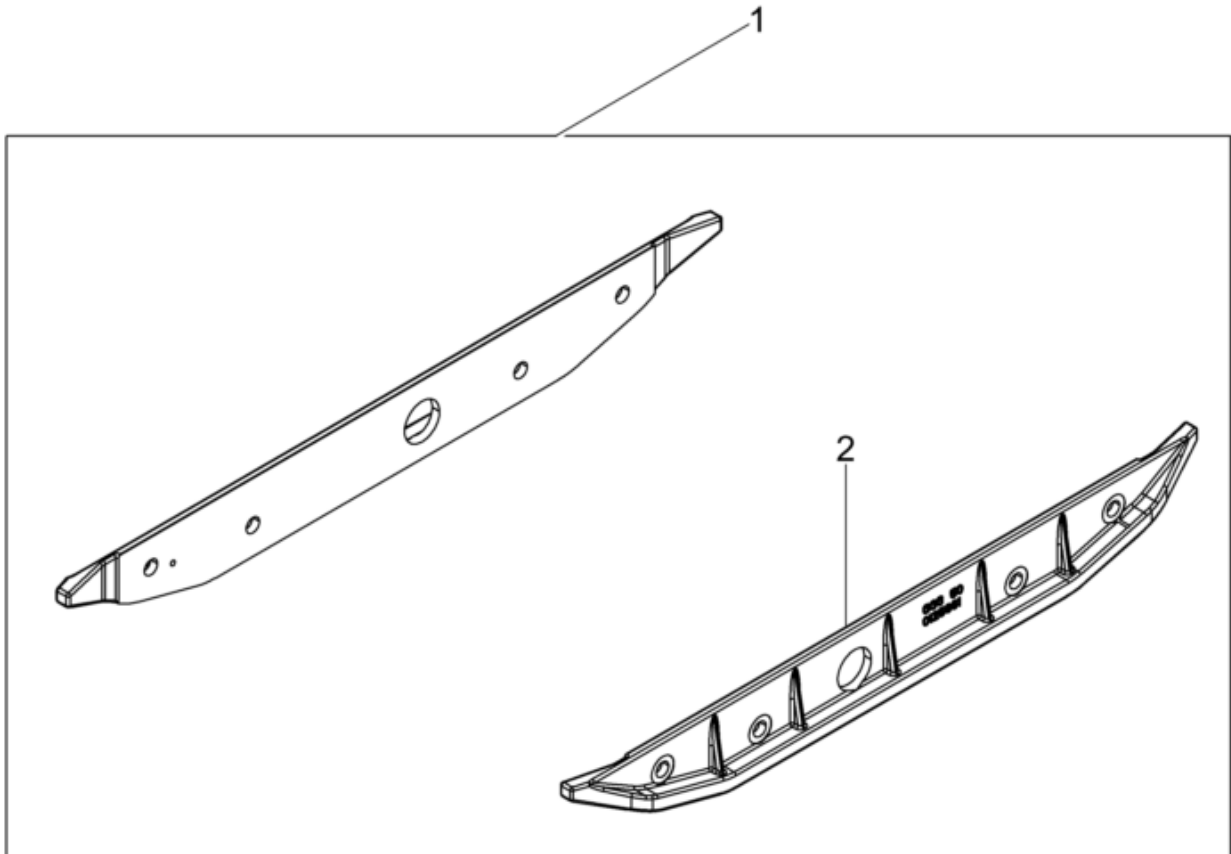

Ref. Pos.	Part No. Artikel Nr.	Qty. St.	Description Beschreibung	Descripción Description	Measur./Abm.	Norm
					Torque/Drehm.	Sealant Schmierstoff
1	0126290	1	Extension plate kit Anbauplattensatz	Juego de placa de extensión Jeu de elargisseur	3	
2	0125662	2	Extension plate Anbauplatte	Placa de extensión Elargisseur	3 cm	

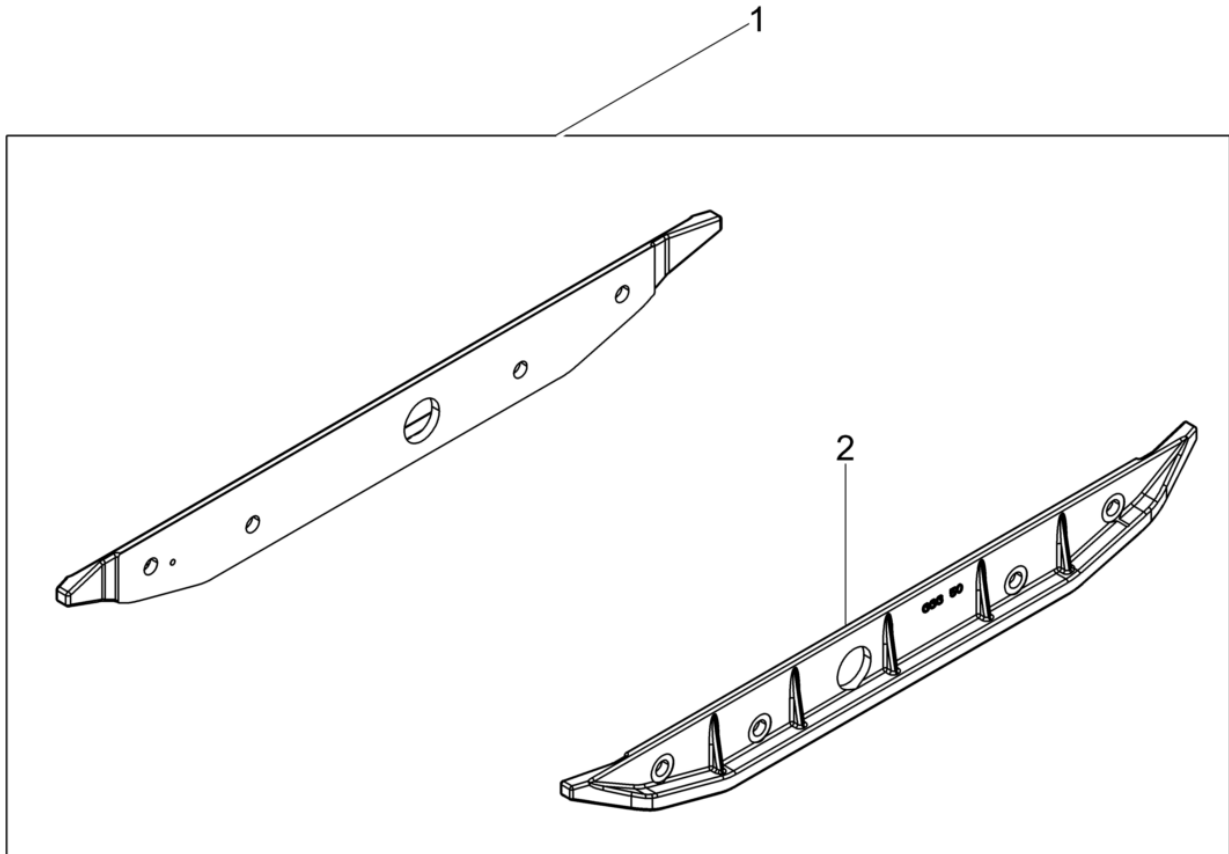

Ref. Pos.	Part No. Artikel Nr.	Qty. St.	Description Beschreibung	Descripción Description	Measur./Abm.	Norm
					Torque/Drehm.	Sealant Schmierstoff
1	0045201	1	Extension plate kit Anbauplattensatz	Juego de placa de extensión Jeu de elargisseur	3in	
2	0044442	2	Extension plate Anbauplatte	Placa de extensión Elargisseur	8 cm	

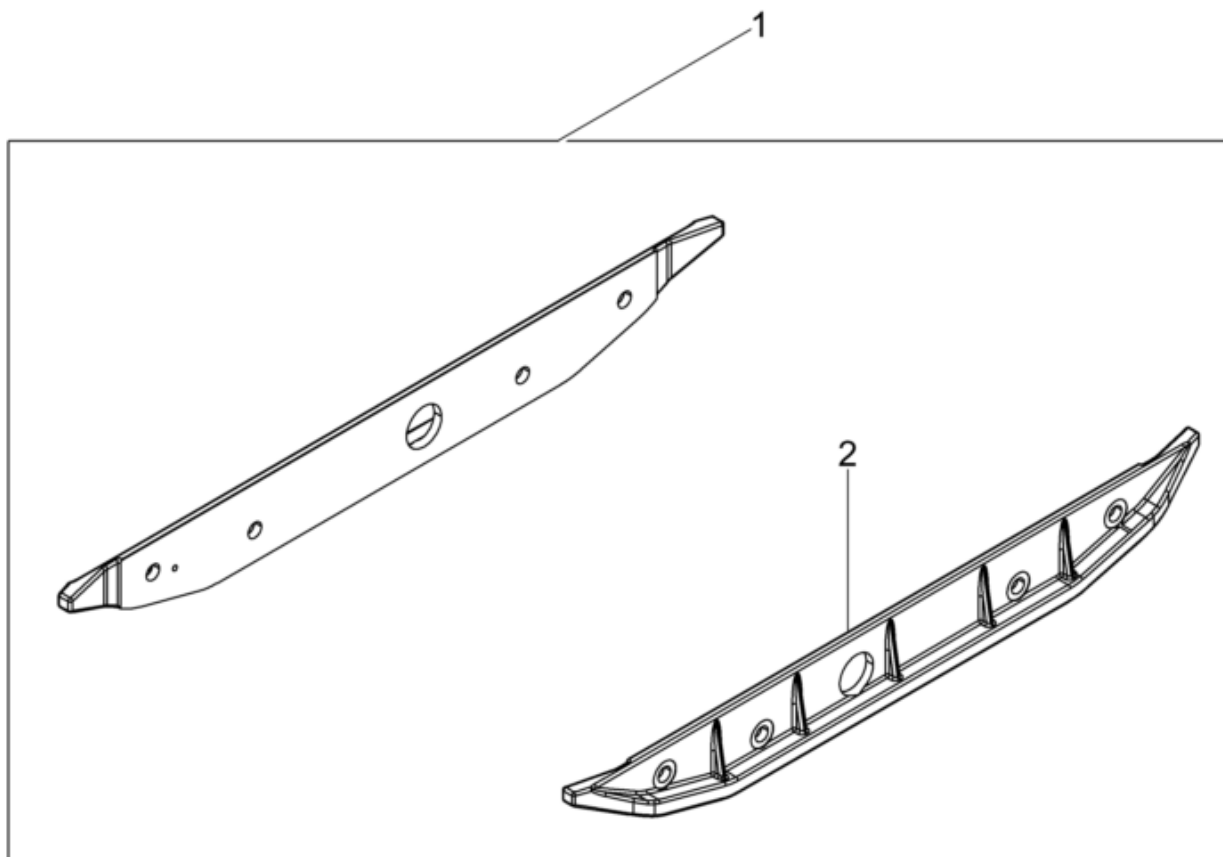

Ref. Pos.	Part No. Artikel Nr.	Qty. St.	Description Beschreibung	Descripción Description	Measur./Abm.	Norm
					Torque/Drehm.	Sealant Schmierstoff
1	0043246	1	Extension plate kit Anbauplattensatz	Juego de placa de extensión Jeu de elargisseur	15	
2	0043245	1	Extension plate Anbauplatte	Placa de extensión Elargisseur	860mm	

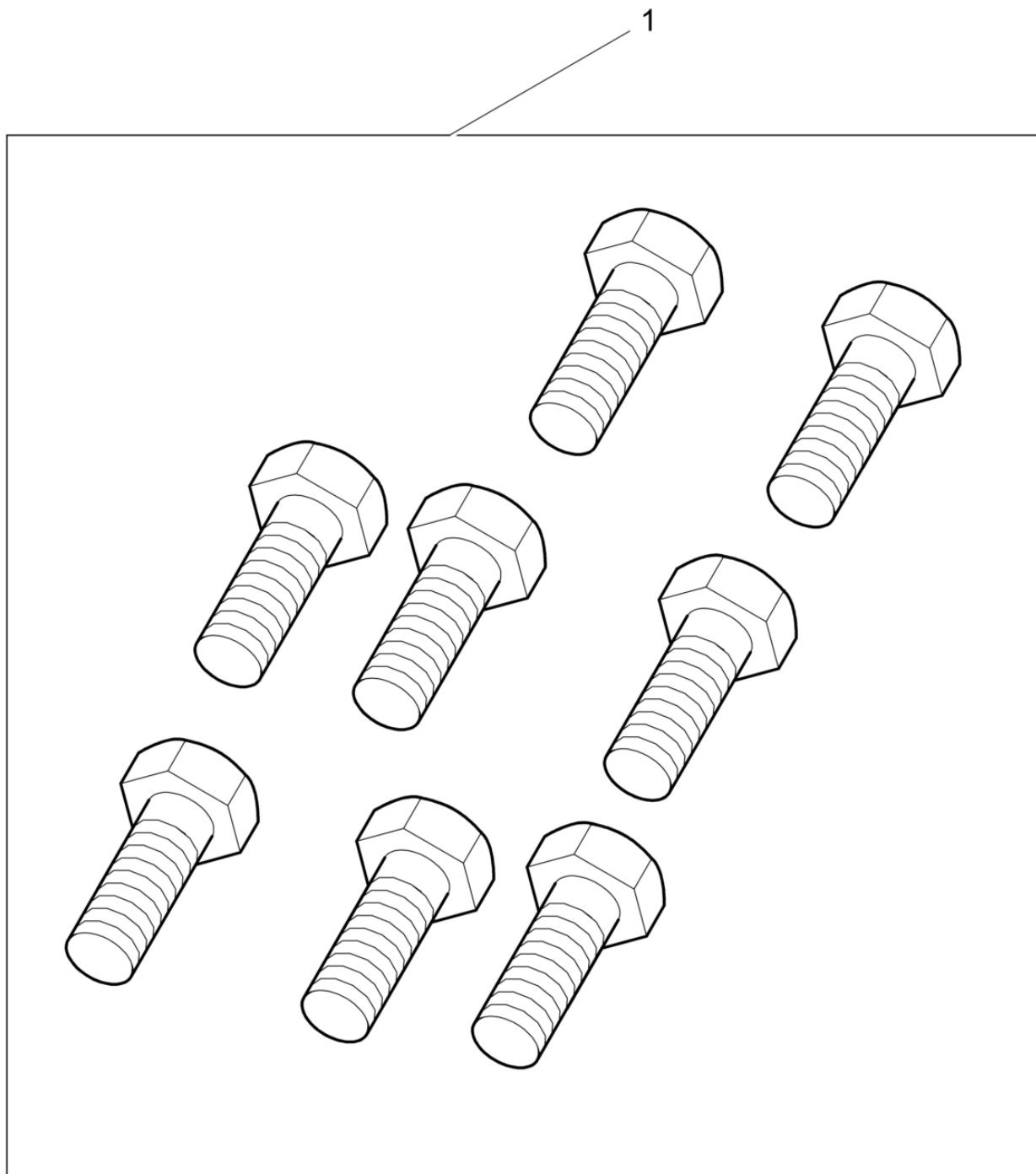

Ref. Pos.	Part No. Artikel Nr.	Qty. St.	Description Beschreibung	Descripción Description	Measurement./Abm.	Norm
					Torque/Drehm.	Sealant Schmierstoff
1	0067519	1	Set of screws Schraubensatz	Juego de tornillos Jeu de vis		

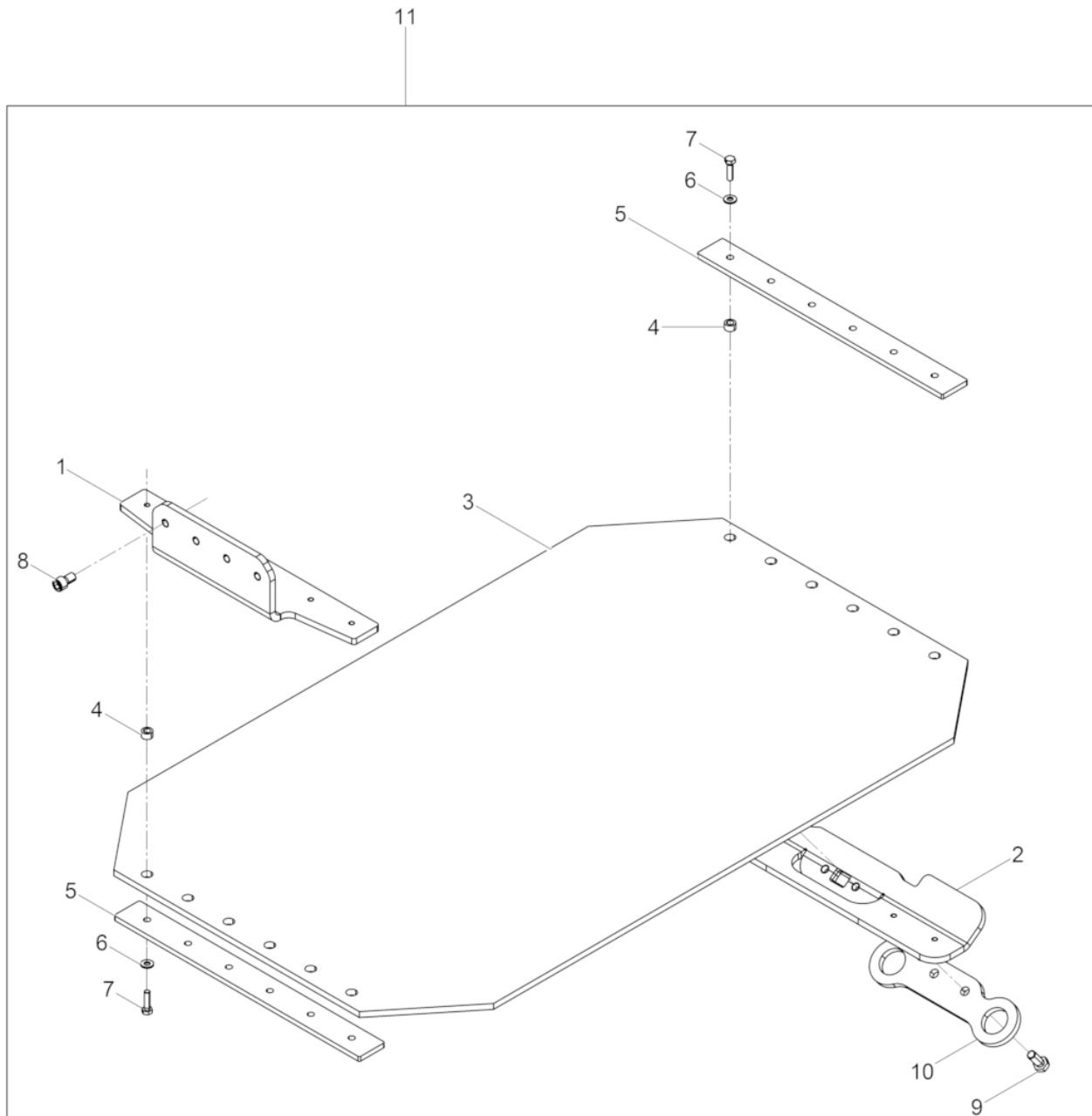

Ref. Pos.	Part No. Artikel Nr.	Qty. St.	Description Beschreibung	Descripción Description	Measurement./Abm.	Norm
					Torque/Drehm.	Sealant Schmierstoff
1	0205208	1	Front Angle Winkel	Angulo delantera Angle de front		
2	5100010936	1	Angle rear Winkel hinten	Angulo atrás Angle arrière		
3	0205209	1	urethane plate Kunststoffplatte	Juego de lamina de uretano Dispositif de glissement		
4	0047577	10	Bushing Buchse	Buje Douille		
5	0058358	2	Bar Leiste	Listón Listeau		
6	0033198	10	Lockwasher Spannscheibe	Arandela elástica Rondelle de ressort	8	DIN6796
7	0011456	10	Hexagonal head cap screw Sechskantschraube	Tornillo hexagonal Vis à tête hexagonale	M8 x 30 25Nm/18ft.lbs	DIN933
8	0011531	4	Cheese head screw Zylinderschraube	Tornillo cilíndrico Vis à tête cylindrique	M12 x 20 86Nm/63ft.lbs	ISO4762
9	0011423	2	Hexagonal head cap screw Sechskantschraube	Tornillo hexagonal Vis à tête hexagonale	M12 x 30 210Nm/155ft.lbs	DIN933
10	5100010935	1	Plate Blech	Chapa Tôle		
11	5100009998	1	Urethane Pad Kit PGV DPU 6555 Gleitvorrichtung	Placa de Deslizamiento PGV DPU 6555 Jeu de Tapis en Polyuréthane		

Starting crank
Andrehkurbel Rückschlagsicher
Manivela de arranque
Manivelle de démarrage

DPU 6555Hs

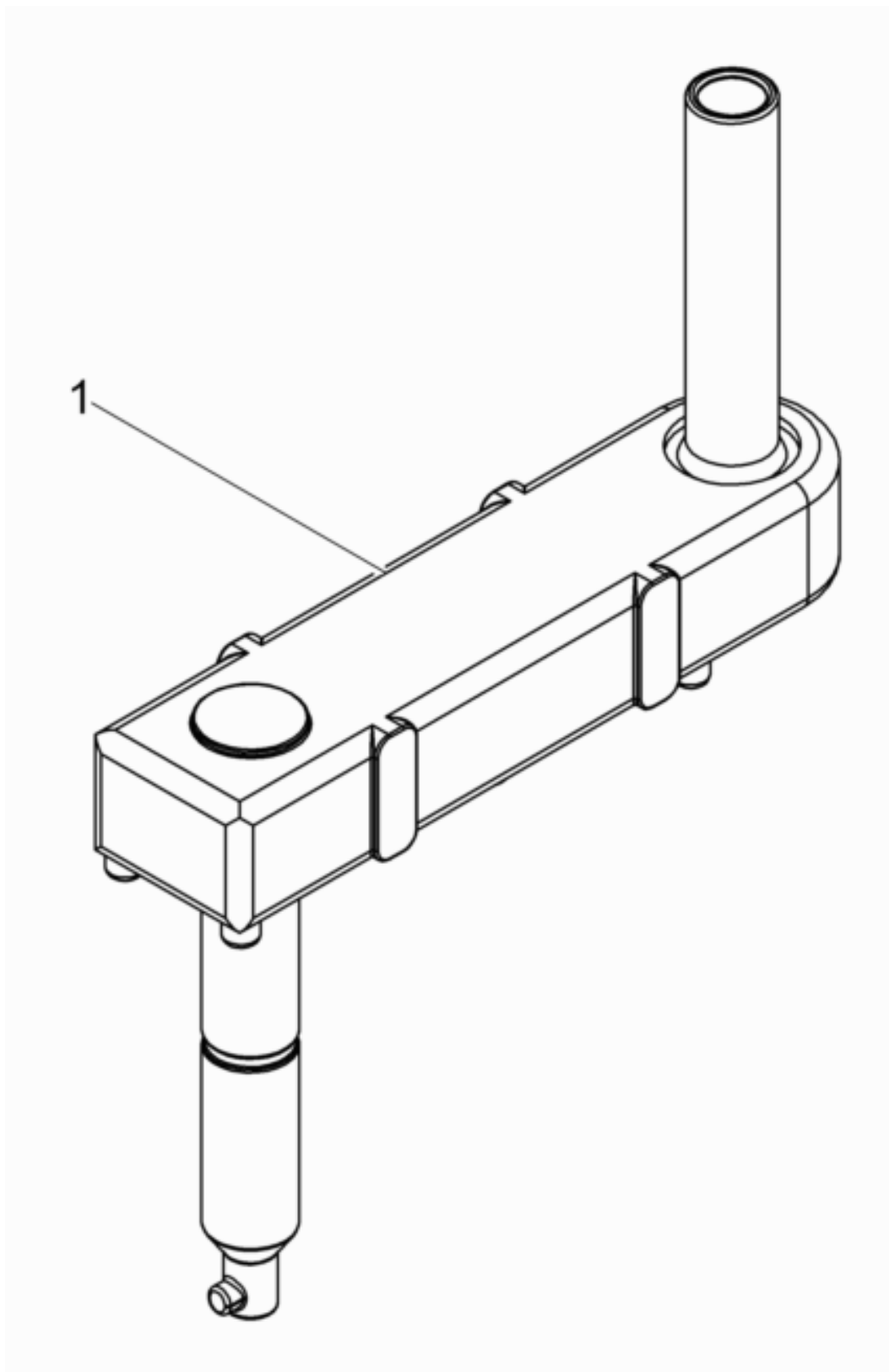

Ref. Pos.	Part No. Artikel Nr.	Qty. St.	Description Beschreibung	Descripción Description	Measurement./Abm.	Norm
					Torque/Drehm.	Sealant Schmierstoff
1	0095187	1	Starting crank Andrehkurbel rückschlagsicher	Manivela de arranque Manivelle de démarrage		

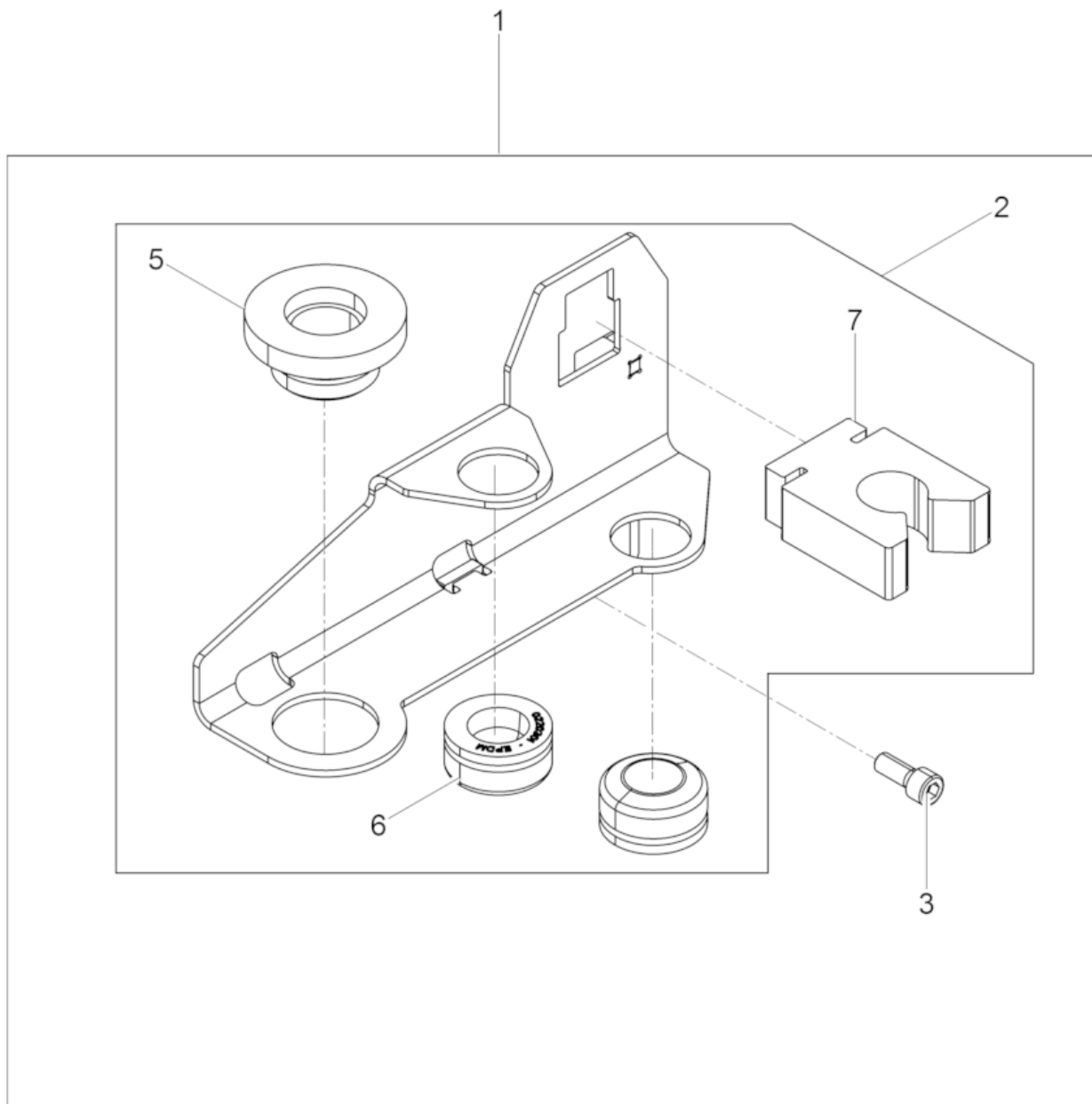

Ref. Pos.	Part No. Artikel Nr.	Qty. St.	Description Beschreibung	Descripción Description	Measurement./Abm.	Norm
					Torque/Drehm.	Sealant Schmierstoff
1	0220473	1	Kit-mounting-Starting crank Anbausatz	Juego-instalación-Manivela de arranque Jeu de montage-Manivelle de		
2	5100003970	1	Crank holder cpl. Kurbelhalter kpl.	Porta-manivela cpl. Support manivelle cpl.		
3	0011535	2	Cheese head screw Zylinderschraube	Tornillo cilíndrico Vis à tête cylindrique	M10 x 25 49Nm/36ft.lbs	ISO4762
5	0220300	1	Bush Gummibuchse	Buje Boîte		
6	0220301	2	Shockmount Puffer	Amortiguador Silentbloc		
7	0220239	1	Bracket Halterung	Soporte Équerre		

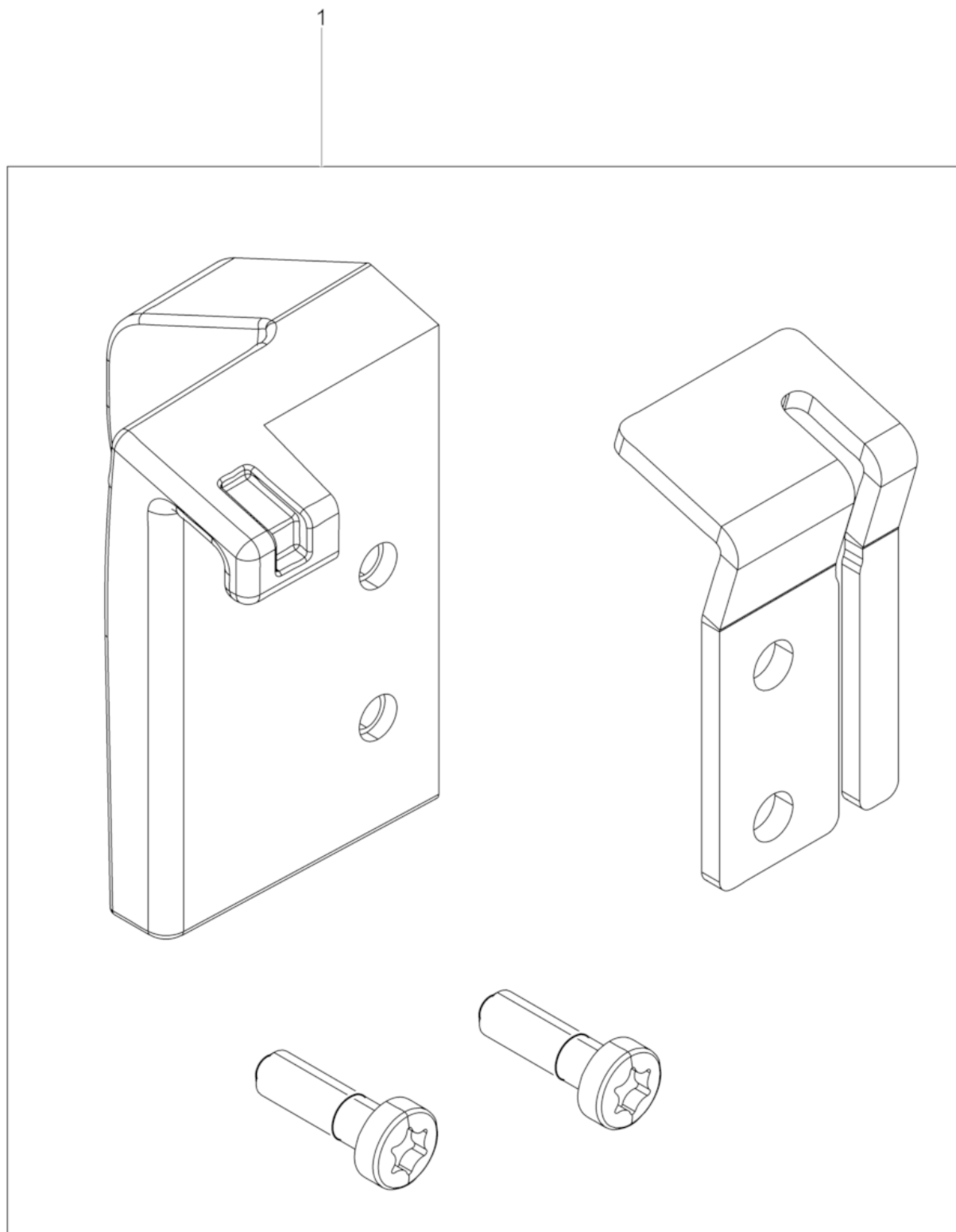

Ref. Pos.	Part No. Artikel Nr.	Qty. St.	Description Beschreibung	Descripción Description	Measurem./Abm.	Norm
					Torque/Drehm.	Sealant Schmierstoff
1	5100005821	1	Kit-retrofit belt guide Nachrüstsatz Riemenberuhiger	Juego de modificación guía de correa Lot de rattrapage		



**WACKER
NEUSON**