



**WACKER
NEUSON**

5100009652	103
04.2018	

**Reversible Plates
Reversierbare Platten
Planchas Reversibles
Plaques réversible**

DPU5545Heh

**Parts Book
Ersatzteile
Lista de Repuestos
Liste de Pièces de Rechange**

www.wackerneuson.com

A nameplate listing the Model Number, Item Number, Revision, and Serial Number is attached to each unit. Please record the information found on this plate so it will be available should the nameplate become lost or damaged. When ordering parts or requesting service information, you will always be asked to specify the model, item number, revision number, and serial number of the unit.

Ein Typenschild mit Typ, Artikelnummer, Version und Maschinen-Nummer ist an jedem Gerät angebracht. Die Daten von diesem Schild bitte notieren, damit sie auch bei Verlust oder Beschädigung des Schildes noch vorhanden sind. Der Typ, die Artikel-Nummer, die Versions- Nummer und die Maschinen-Nummer sind bei der Ersatzteilbestellung oder Nachfragen bezüglich Service-Informationen stets erforderlich.

Una placa de identificación con el modelo, número de referencia, nivel de revisión y número de serie ha sido añadida en cada máquina. Favor de anotar los datos en la placa en caso de que la placa de identificación sea destruida o perdida. En todos los pedidos para repuestos necesita siempre el modelo, el número de referencia, el nivel de revisión y el número de serie de la máquina en cuestión.

Une plaque signalétique mentionnant le modèle, le numéro de référence, le niveau de révision et le numéro de série est fixée sur chaque machine. Veuillez noter les informations relevées sur cette plaque de façon à ce qu'elles soient toujours disponibles si la plaque signalétique venait à être perdue ou endommagée. Lorsque vous commandez des pièces détachées ou vous sollicitez des informations après-vente, on vous demandera toujours de préciser le modèle, le numéro de référence, le niveau de révision et le numéro de série de la machine.

***My machine's numbers are / Die Nummern meines Gerätes sind /
Los números de mi máquina son / Les numéros de ma machine son :***



Part Numbers appearing in boldface type are recommended spare parts. This means that these parts are subject to wear under normal operating conditions and may require periodic service or replacement. It is recommended that these items be stocked to meet the expected service requirements of this model. Actual stocking quantities of these and other parts used in more extensive repairs will depend on the service practices of each customer.

Bei den in den Ersatzteillisten fettgedruckten Nummern handelt es sich um empfohlene Ersatzteile. Dies bedeutet, daß diese Teile bei normalen Anwendungsbedingungen natürlicher Abnutzung ausgesetzt sind und gelegentlich ersetzt oder überarbeitet werden müssen. Es wird geraten, diese Teile auf Lager bereit zu haben, um für Service-Arbeiten an diesem Gerät vorbereitet zu sein. Lagerbestände für diese und andere Teile, welche für ausgiebigere Reparaturarbeiten benötigt werden, können je nach Service-Gewohnheiten der einzelnen Kunden variieren.

Los números de partes en negritas en las Listas Ilustradas de Partes son los repuestos recomendados, ésto quiere decir que estas partes se desgastarán bajo circunstancias de funcionamiento normales y pueden requerir servicio periódico o su reemplazo. Se recomienda que el cliente mantenga un abastecimiento adecuado de estas partes para poder satisfacer la demanda requerida por el servicio a la máquina. La cantidad de repuestos que el cliente necesitará para reparaciones dependerá de la póliza de servicio de cada cliente.

Les numéros de pièces imprimés en caractères gras dans les Listes des Pièces Détachées de ce manuel sont les pièces détachées recommandées par la Wacker. Cela veut dire que ces pièces sont sujettes à usure dans des conditions de travail normales et peuvent nécessiter de l'entretien ou leur remplacement. Nous recommandons que vous disposez d'un stock de ces pièces pour pouvoir satisfaire la demande d'entretien de cette machine. Le client doit décider lui-même de la quantité exacte de pièces de rechange qu'il disposera dans ses stocks.

Vibration Plate Vibrationsplatte Plancha Vibradora Plaque Vibrante	10
Vibration Plate Vibrationsplatte Plancha Vibradora Plaque Vibrante	12
Center pole Scandinavia version Deichsel Skandinavien Ausführung Barra de mando Escandinavia versión Timon Scandinavie version	14
Upper mass Obermasse Masa superior Massa superieure	16
Battery cover cpl. Batteriedeckel kpl. Protección de batería Couvercle de batterie cpl.	20
Battery protection cpl. Batterieschutz kpl. Protección de batería cpl. Protection de batterie cpl.	22
Baseplate Untermasse Masa inferior Masse inferieure	24
Exciter Erreger Excitador Excitatrice	26
Center Pole cpl. Deichsel kpl. Barra de mando cpl. Timon cpl.	30
Center Pole Head cpl. Deichselkopf kpl. Cabezal de mando cpl. Tête de timon cpl.	34
Coupling cpl. Kupplung kpl. Embrague cpl. Embrayage cpl.	36
Centrifugal Clutch cpl. Fliehkraftkupplung kpl. Embrague centrifugo cpl. Embrayage centrifuge cpl.	38
Labels Aufkleber Calcomanías Autocollants	40
Vibration Plate Vibrationsplatte Plancha Vibradora Plaque Vibrante	42

Indice

Table des matières

Engine Motor Motor Moteur	45
Crankcase Kurbelgehäuse Cárter Carter	46
Crankcase cpl. Kurbelgehäuse kpl. Cárter cpl. Carter cpl.	48
Crankshaft - Mounting flange Kurbelwelle-Lagerflansch Cigüeñal - Brida Vilebrequin - Bourrelet	52
Camshaft Nockenwelle Árbol de Levas Arbre à Cames	54
Piston-Connecting Rod-Cylinder Kolben-Pleuel-Zylinder Pistón-Biela-Cilindro Piston-Bielle-Cylindre	56
Cylinder head Zylinderkopf Culata Culasse	58
Push rod-Fly wheel Stoßstange-Schwungrad Varilla de empuje-Volante Poussoir-Volant	64
Oil Pump-Governor Ölpumpe-Regler Bomba de Aceite-Regulador Pompe à Huile-Régulateur	66
Command Cover Steuerdeckel Tapa del mando Couvercle de commande	68
Injection Equipment Einspritzaurüstung Sistema Inyectora Système d'Injection	70
Air Ducting Luftführung Conducción de Aire Carter Ventilation	74
Breather - Governor Entlüftung-Drehzahlverstellung Purgado - Regulador de Revoluciones Raccord Fileté de Purge -	76
Fuel Tank Kraftstofftank Depósito de Combustible Réservoir à Essence	80

Air Cleaner Luftfilter Filtro del Aire Filtre à Air	84
Exhaust Silencer Abgasdämpfer Silenciador Silencieux	88
Starting crank Andrehkurbel Manivela de arranque Manivelle de démarrage	90
Starter-Generator Starter-Generator Arrancador-Generador Démarreur-Générateur	92
Automatic shut-off Abschaltautomatik Cierre automático Interruption automatique	96
Coupling housing Anschlußgehäuse Caja de conexión Carter de branchement	100
Engine Equipment EPA Motorausrüstung EPA Equipamiento de Motor EPA Equipement Moteur EPA	102
Spare Parts Kits Ersatzteilsätze Juegos de Repuestos Jeu de Pièces de Rechange	104
Accessoires Zubehör Accesorios Accessories	107
Extension plate kit Anbauplatten-Satz Juego de placa de extensión Jeu de elargisseur	108
Extension plate kit Anbauplatten-Satz Juego de placa de extensión Jeu de elargisseur	110
Extension plate kit Anbauplatten-Satz Juego de placa de extensión Jeu de elargisseur	112
Set of screws Schraubensatz Juego de tornillos Jeu de vis	114
Urethane Pad PGV 4045-5545 Gleitvorrichtung PGV 4045-5545 Placa de DeslizamientoPGV 4045-5545 Jeu de Tapis en Polyuréthane	116

Starting crank Andrehkurbel Manivela de arranque Manivelle de démarrage	118
Kit-mounting-Starting crank Anbausatz Andrehkurbel Juego-instalación-Manivela de arranque Jeu de montage-Manivelle de	120
Trolley cpl. Fahrgestell kpl. Dispositivo de Transporte cpl. Chassis cpl.	122
Kit-retrofit belt guide Nachrüstsatz Riemenberuhiger Juego de modificaciónguía de correa Lot de rattrapage	124
Kit-retrofit DPU40../45../55.. Nachrüstsatz Rental DPU40../45../55.. Juego de modificación DPU40../45../55.. Lot de rattrapage	126

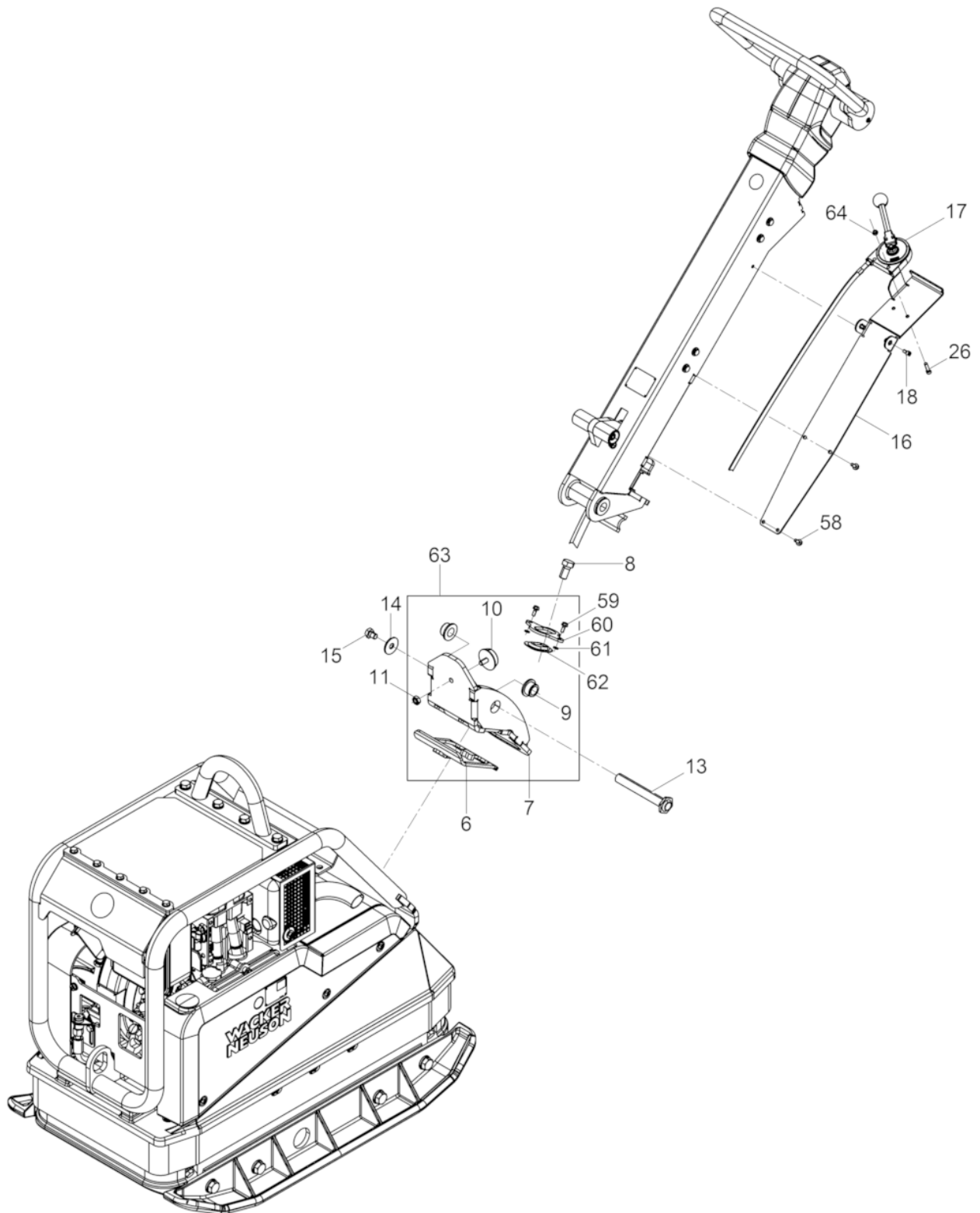

Ref. Pos.	Part No. Artikel Nr.	Qty. St.	Description Beschreibung	Descripción Description	Measurement/Abm.	Norm
					Torque/Drehm.	Sealant Schmierstoff
6	5100010503	1	Profiled joint Dichtungsprofil	Junta Joint d'étanchéité profilé		
7	5100003725	1	Support Deichselbock	Caballote de apoyo Support		
8	0011523	4	Hexagonal head cap screw Sechskantschraube	Tornillo hexagonal Vis à tête hexagonale	M16 x 30 210Nm/155ft.lbs	DIN933
9	5100004367	2	Bush Buchse	Buje Boîte		
10	5100005558	1	Shockmount Anschlagpuffer	Amortiguador Silentbloc	50 x 18 M10 x 20	
11	0010883	1	Hexagon nut Sechskantmutter	Tuerca hexagonal Écrou hexagonal		
13	5100009632	1	Axle Achse	Eje Axe		
14	0010376	1	Flat washer Scheibe	Arandela Rondelle	A13	DIN9021
15	0014316	1	Hexagonal head cap screw Sechskantschraube	Tornillo hexagonal Vis à tête hexagonale	M12 x 16 86Nm/63ft.lbs	DIN933
16	5100009950	1	Cover Plate cpl. Deckblech kpl.	Cubierta de Chapa cpl. Coife cpl.		
17	5100036296	1	Control Betätigung	Regulador Commande		
18	0011553	2	Cheese head screw Zylinderschraube	Tornillo cilíndrico Vis à tête cylindrique		
26	0011550	2	Cheese head screw Zylinderschraube	Tornillo cilíndrico Vis à tête cylindrique	M6 x 25 10Nm/7ft.lbs	ISO4762
58	0204408	4	Screw Schraube	Tornillo Vis	DE M 6x 16	DIN7500
59	0204408	2	Screw Schraube	Tornillo Vis	DE M 6x 16	DIN7500
60	5100010505	1	Plate Blech	Chapa Tôle		
61	0010744	2	Washer Scheibe	Arandela Rondelle	6,4	DIN433
62	5100010504	1	Gasket Dichtung	Junta Joint		
63	5100010938	1	Support cpl. Deichselbock kpl.	Caballote de apoyo cpl. Support cpl.		
64	0010880	2	Hexagon nut Sechskantmutter	Tuerca hexagonal Écrou hexagonal		

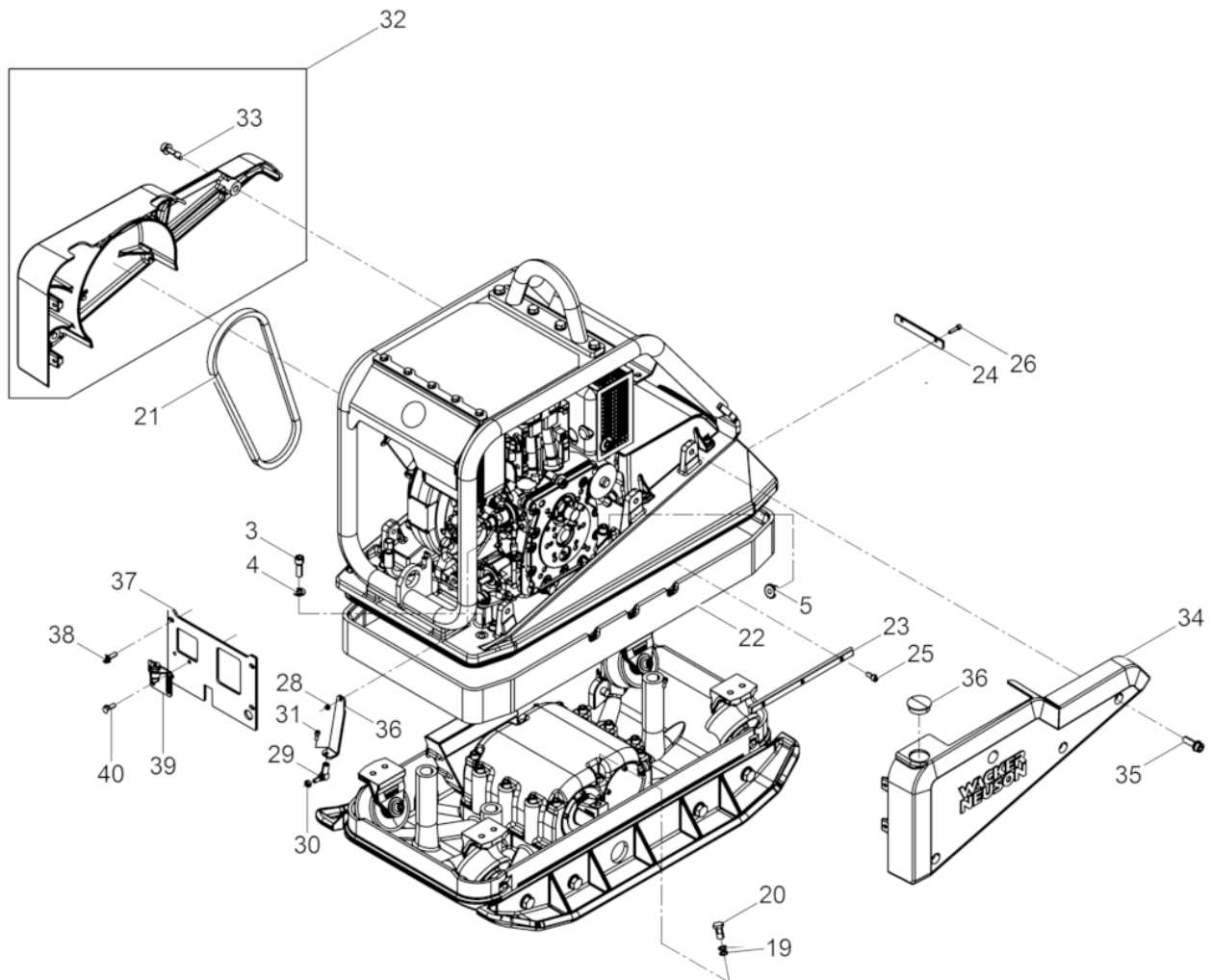

Ref. Pos.	Part No. Artikel Nr.	Qty. St.	Description Beschreibung	Descripción Description	Measurement./Abm.	Norm
					Torque/Drehm.	Sealant Schmierstoff
3	0011528	8	Cheese head screw Zylinderschraube	Tornillo cilíndrico Vis à tête cylindrique	M12 x 35 86Nm/63ft.lbs	ISO4762
4	0021465	8	Lock washer Sicherungsscheibe	Arandela de seguridad Rondelle d'arrêt	HS12	
5	0103880	1	Pipe guide Rohrdurchführung	Tubo de guía Passage de tuyau		
19	0012624	2	Gasket Dichtring	Anillo de junta Bague d'étanchéité	A14 x 18	DIN7603
20	0043201	1	Banjo bolt Hohlschraube	Perno hueco Boulon creux à filet femelle	10-3	DIN7643
21	0058889	1	V-belt Keilriemen	Correa en V Courroie		
22	5100009634	1	Apron Schürze	Protección Tablier		
23	0097110	2	Bar Leiste	Listón Listeau		
24	5100009635	1	Bar Leiste	Listón Listeau		
25	0103962	6	Cheese head screw Zylinderschraube	Tornillo cilíndrico Vis à tête cylindrique	M8 x 18 25Nm/18ft.lbs	ISO4762
26	0011550	2	Cheese head screw Zylinderschraube	Tornillo cilíndrico Vis à tête cylindrique	M6 x 25 10Nm/7ft.lbs	ISO4762
27	0103971	1	Lever Hebel	Palanca Levier		
28	0021679	1	Hexagon nut Sechskantmutter	Tuerca hexagonal Écrou hexagonal	M6	DIN980
29	0038403	1	Angular joint Winkelgelenk	Articulación angular Jointure engulaire	AS13	DIN71802
30	0010882	1	Hexagon nut Sechskantmutter	Tuerca hexagonal Écrou hexagonal		
31	0011553	1	Cheese head screw Zylinderschraube	Tornillo cilíndrico Vis à tête cylindrique	10Nm/7ft.lbs	
32	5100002779	1	Belt guard Riemenschutz	Protección de la polea Protection de courroie		
33	0220202	3	Screw Dünnschaftschraube	Tornillo Vis	M12x 40	
34	0220319	1	Protective hood Schutzhaube	Cubierta de protección Capot de protection		
35	0220325	3	Screw Sicherungsschraube	Tornillo Vis	M 12x 35	
36	0126654	1	Locking plug Verschlußstopfen	Tapón de cierre Bouchon de fermeture	M26 x 1,5	
37	0220225	1	Guard plate Schutzblech	Chapa protectora Tôle de protection		
38	0129420	4	Socket head cap screw Zylindersicherungsschraube	Tornillo de seguridad Poignée supplémentaire		
39	0097896	1	Oil drain cpl. Ölablaß kpl.	Drenaje de aceite cpl. Raccord vidange d'huile cpl.		
40	0105944	2	Screw Schraube	Tornillo Vis	DE M8 x 20	DIN7500

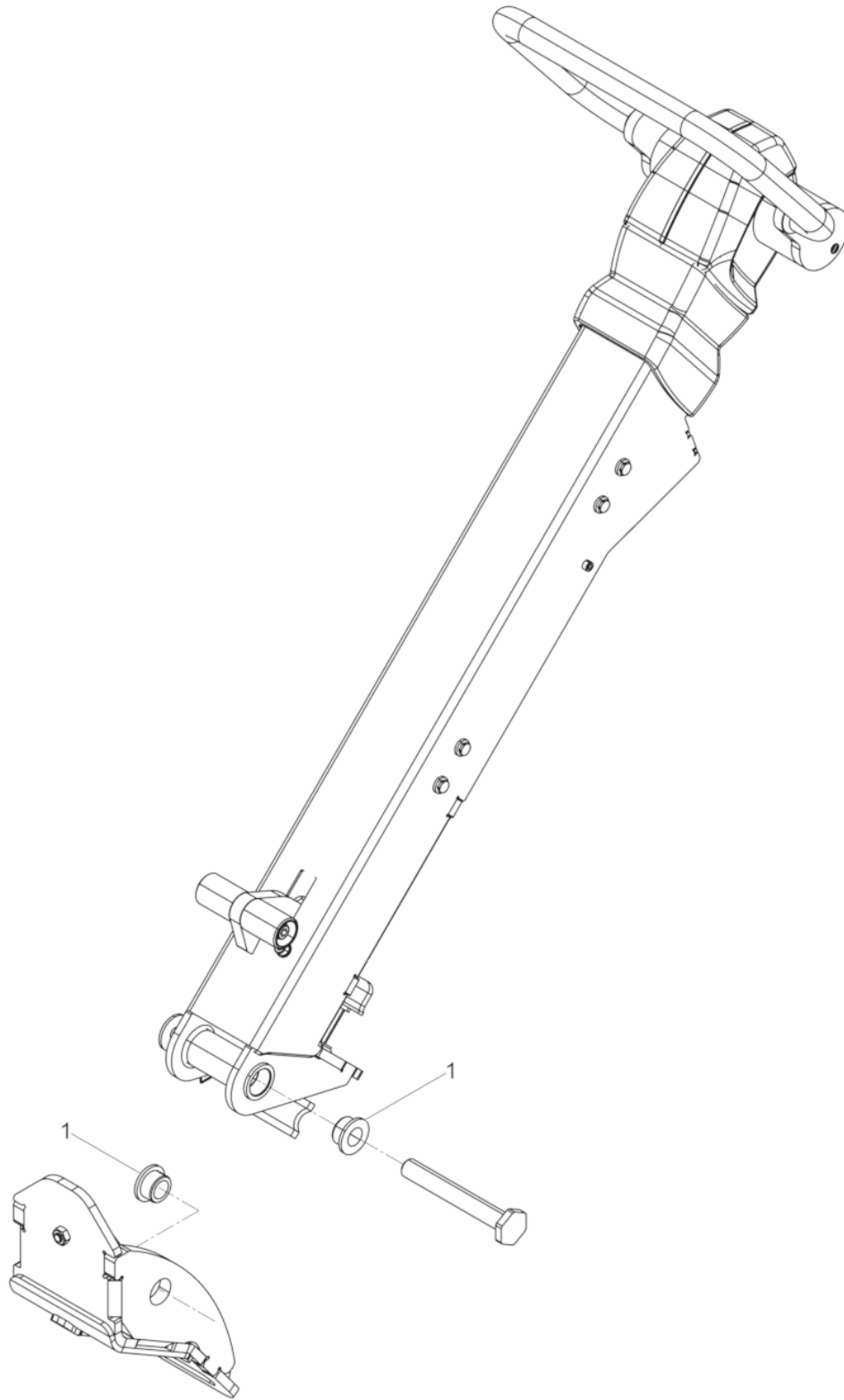

DPU5545Heh

Center pole Scandinavia version
Deichsel Skandinavien Ausführung
Barra de mando Escandinavia versión
Timon Scandinavie version

Ref. Pos.	Part No. Artikel Nr.	Qty. St.	Description Beschreibung	Descripción Description	Measurement./Abm.	Norm
					Torque/Drehm.	Sealant Schmierstoff
1	5100042458	4	brass bush Messingbuchse	Buje de latón Boîte en laiton		

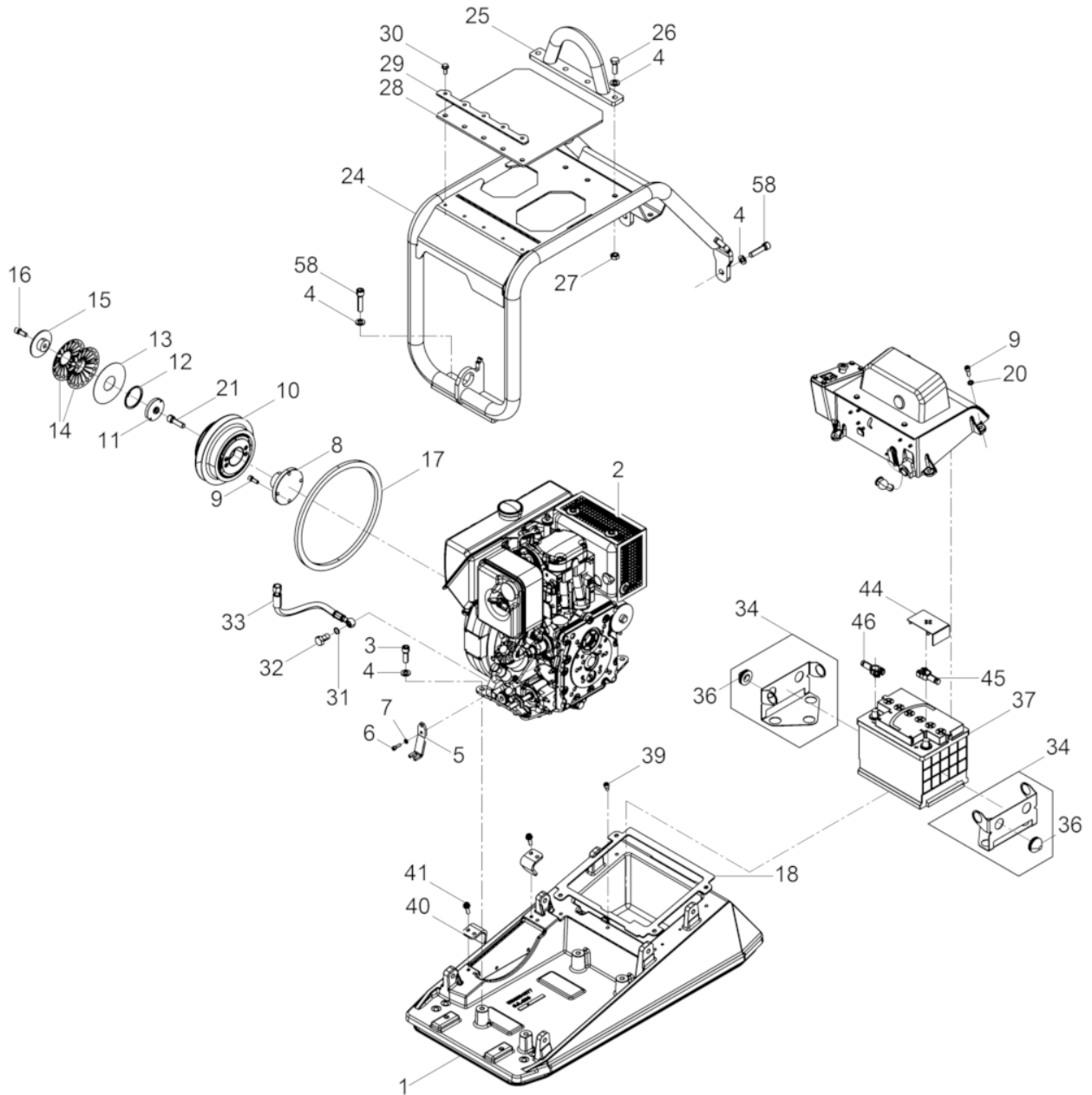

Ref. Pos.	Part No. Artikel Nr.	Qty. St.	Description Beschreibung	Descripción Description	Measurement/Abm.	Norm
					Torque/Drehm.	Sealant Schmierstoff
1	5100004978	1	Upper Mass Obermasse	Masa Superior Masse Superieure		
2	0220375	1	Diesel engine Dieselmotor	Motor diesel Moteur diesel		
3	0011528	4	Cheese head screw Zylinderschraube	Tornillo cilíndrico Vis à tête cylindrique	M12 x 35 86Nm/63ft.lbs	ISO4762
4	0021465	12	Lock washer Sicherungsscheibe	Arandela de seguridad Rondelle d'arrêt	HS12	
5	0103893	1	Angle Winkel	Ángulo Coude		
6	0011551	2	Cheese head screw Zylinderschraube	Tornillo cilíndrico Vis à tête cylindrique	10Nm/7ft.lbs	
7	0010624	2	Flat washer Scheibe	Arandela Rondelle		
8	0103129	1	Flange Flansch	Brida Bride		
9	0012629	8	Cheese head screw Zylinderschraube	Tornillo cilíndrico Vis à tête cylindrique	25Nm/18ft.lbs	
10	0102208	1	Coupling cpl. Kupplung kpl.	Embrague cpl. Embrayage cpl.		
11	0058546	1	Disc Scheibe	Disco Disque		
12	0021147	1	Retaining ring Sicherungsring	Anillo de retención Bague d'arrêt	60 x 2	DIN472
13	0048273	1	Seal Dichtung	Junta Joint		
14	0048374	2	Cup spring Tellerfeder	Resorte de platillo Ressort belleville		
15	0058547	1	Button Pilz	Fungiforme Butée		
16	0011534	1	Cheese head screw Zylinderschraube	Tornillo cilíndrico Vis à tête cylindrique	M10 x 30 49Nm/36ft.lbs	ISO4762
17	0103104	1	Four edge cord Vierkantschnur	Cordón rectangular Corde carrée		
18	0220232	1	Gasket Dichtung	Junta de estanqueidad Garniture		
20	0010742	4	Washer Scheibe	Arandela Rondelle		
21	5100010091	1	Cheese head screw Zylinderschraube	Tornillo cilíndrico Vis à tête cylindrique	M12x 40 86Nm/63ft.lbs	
24	0220235	1	Protective frame Schutzrahmen	Armazón de protección Cadre protection		
25	0103930	1	Hook Öse	Punto de izaje Crochet		
26	0011422	4	Hexagonal head cap screw Sechskantschraube	Tornillo hexagonal Vis à tête hexagonale	M12 x 35 86Nm/63ft.lbs	DIN933
27	0010366	4	Hexagon nut Sechskantmutter	Tuerca hexagonal Écrou hexagonal	M12X1.75	DIN985
28	0102442	1	Cover plate Abdeckplatte	Placa de cubierta Plaque de recouvrement		

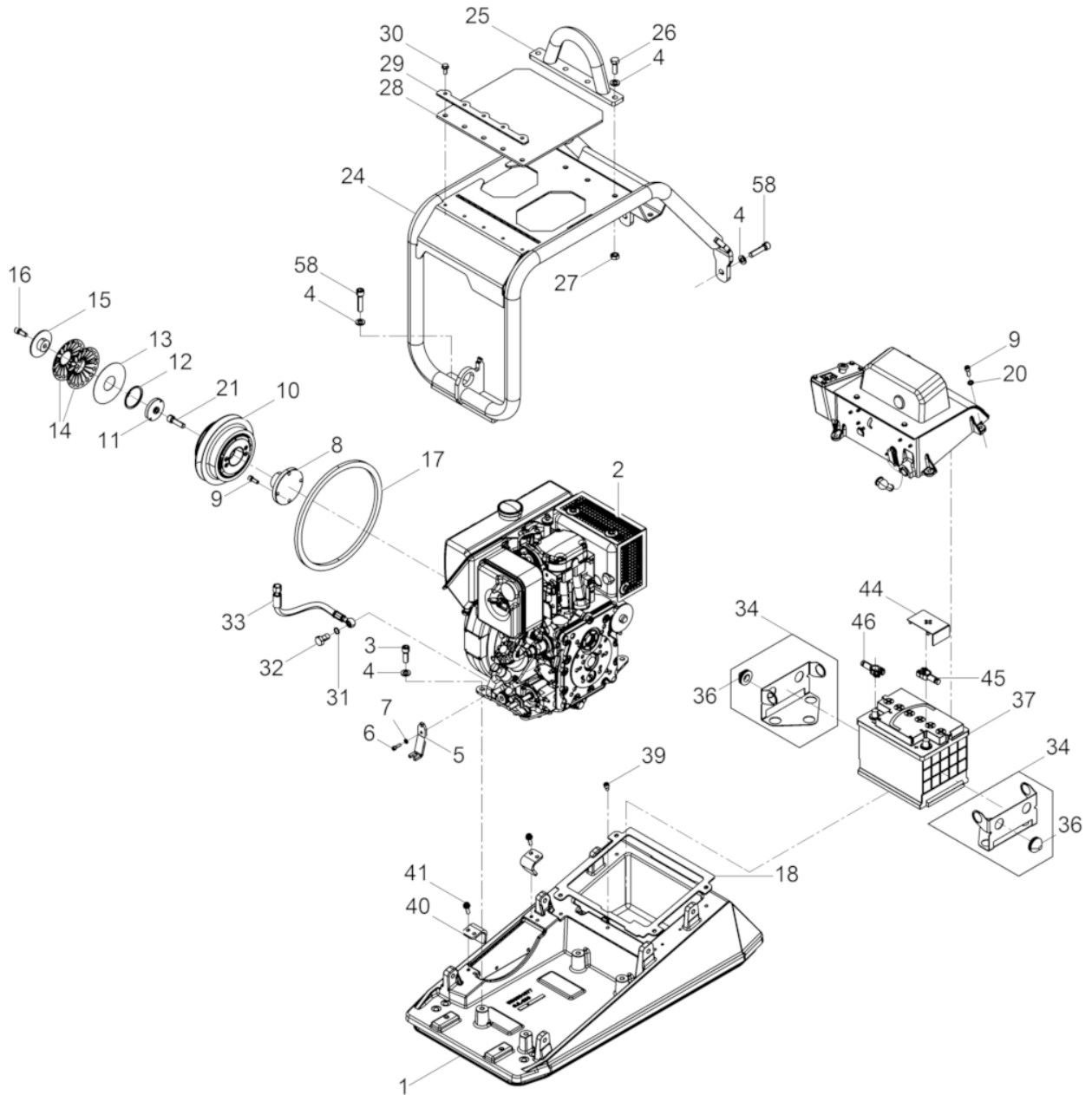

Ref. Pos.	Part No. Artikel Nr.	Qty. St.	Description Beschreibung	Descripción Description	Measurement./Abm.	Norm
					Torque/Drehm.	Sealant Schmierstoff
29	0102443	1	Bar Leiste	Listón>Listeau		
30	0105944	5	Screw Schraube	Tornillo Vis	DE M8 x 20	DIN7500
31	0012624	2	Gasket Dichtring	Anillo de junta Bague d'étanchéité	A14 x 18	DIN7603
32	0043201	1	Banjo bolt Hohlschraube	Perno hueco Boulon creux à filet femelle	10-3	DIN7643
33	0104074	1	Hose pipe Schlauchleitung	Conducto flexible Conduite flexible		
34	5100011287	2	Battery protection cpl. Batterieprotector kpl.	Protección de batería cpl. Protection de batterie cpl.		
36	0124255	16	Shockmount Batteriepuffer	Tope Tampon		
37	5100021329	1	Battery Batterie	Batería Batterie		
39	0013574	2	Cheese head screw Zylinderschraube	Tornillo cilíndrico Vis à tête cylindrique	25Nm/18ft.lbs	
40	0220334	2	Angle Winkel	Angulo Angle		
41	0129420	4	Socket head cap screw Zylindersicherungsschraube	Tornillo de seguridad Poignée supplémentaire		
44	5100011307	1	Positive pol cover Pluspol-Abdeckung	Cubierta Couverture		
45	5100015202	1	pole terminal positive Polklemme Pluspol	terminal de polo positivo borne polaire positive		
46	5100015203	1	pole terminal negative Polklemme Minuspol	terminal de polo negativo borne polaire negative		
58	0013569	4	Cheese head screw Zylinderschraube	Tornillo cilíndrico Vis à tête cylindrique	M12 x 50 86Nm/63ft.lbs	ISO4762

Battery cover cpl.
Batteriedeckel kpl.

DPU5545Heh

Protección de batería
Couvercle de batterie cpl.

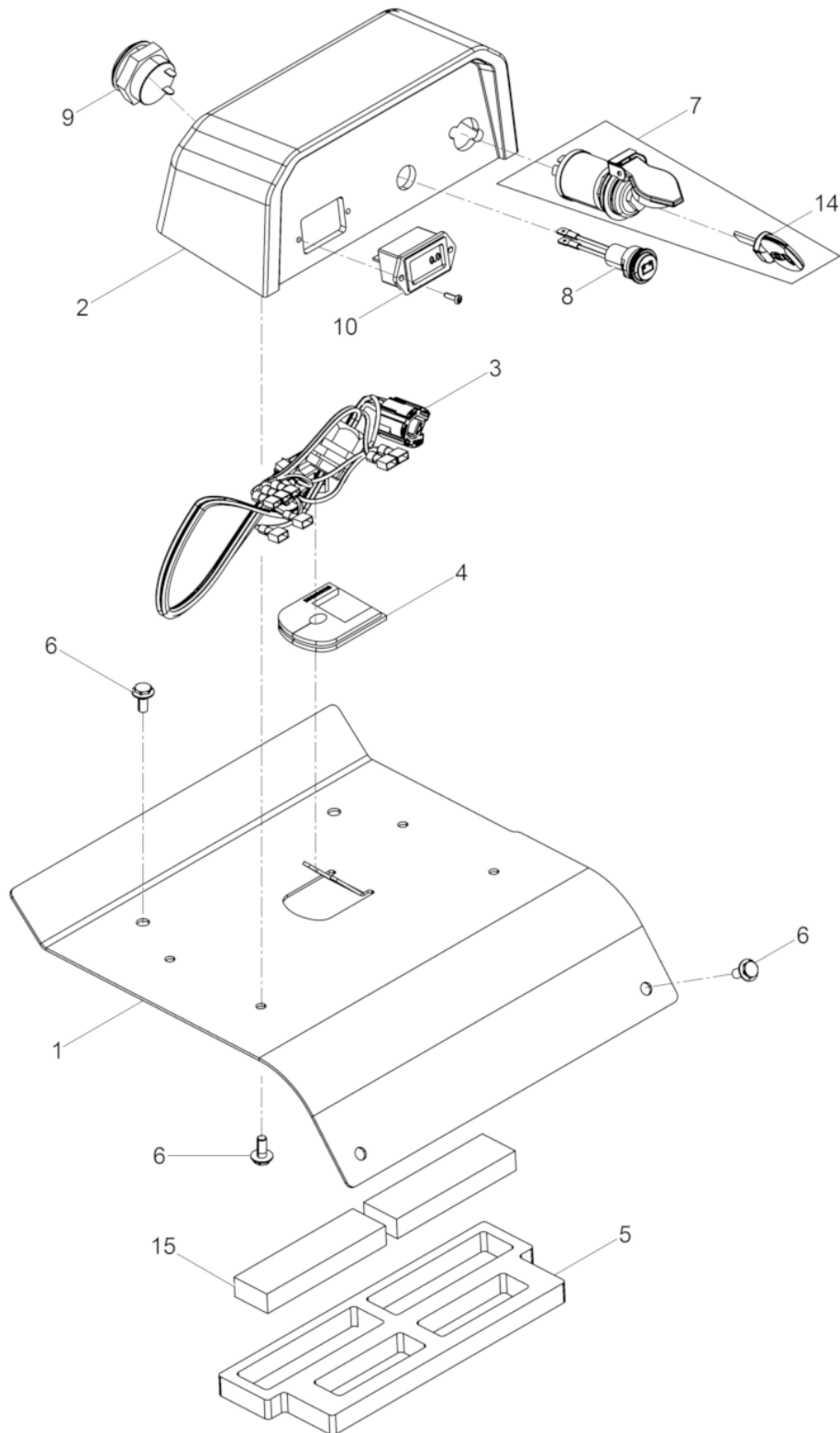

Ref. Pos.	Part No. Artikel Nr.	Qty. St.	Description Beschreibung	Descripción Description	Measurement./Abm.	Norm
					Torque/Drehm.	Sealant Schmierstoff
1	5100020823	1	Battery cover Batteriedeckel	Protección de batería Couvercle de batterie		
2	5100010085	1	Housing Gehäuse	Carcasa Carter		
3	5100009620	1	Helix cable Spiralkabel	Cable espiral Câble spirale		
4	5100009911	1	Gasket Dichtung	Junta Joint		
5	5100020556	1	Insulating cushion Kissen für Batterie	Almohadilla Coussin		
6	0210194	8	corrugated-head screw Sicherungsschraube	Tornillo Vis		
7	5100011296	1	Ignition starter switch Zündanlassschalter	Interruptor de arranque Interrupteur démarreur		
8	0129797	1	LED LED Leuchte	Diodo Diode luminescente		
9	0220234	1	Acoustic signal Signalgeber	Señal acústica Signal acoustique		
10	5100011309	1	Working hour meter Betriebsstundenzähler	Carter del motor Carter de moteur		
14	0220118	1	Key Schlüssel	Llave Clé		
15	5100020618	2	filter mat Filtermatte	estera filtrante élément filtrant		

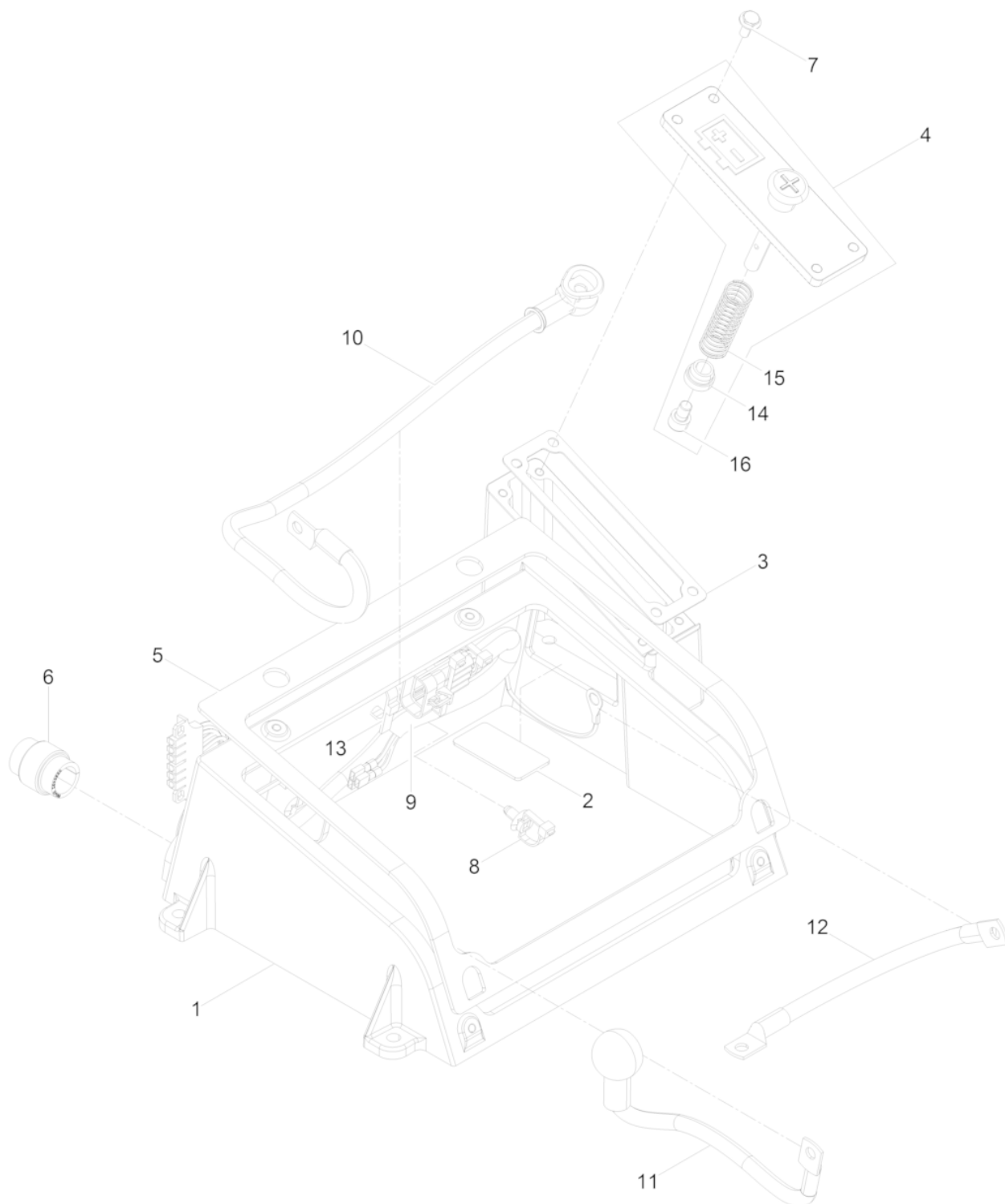

Ref. Pos.	Part No. Artikel Nr.	Qty. St.	Description Beschreibung	Descripción Description	Measurement/Abm.	Norm
					Torque/Drehm.	Sealant Schmierstoff
1	5100011289	1	Battery protection Batterieschutz	Protección de batería Protection de batterie		
2	5100010149	1	Pad Pad	Cojín Coussin		
3	0216678	1	Gasket Dichtung	Junta de estanqueidad Garniture		
4	5100011304	1	Starting device cpl. Starthilfe kpl.	Embolo buzo cpl. Fouloir plongeur cpl.		
5	0220233	1	Gasket Dichtung	Junta de estanqueidad Garniture		
6	0220432	1	Insert Einsatz	Inserto Insertion		
7	0210194	4	corrugated-head screw Sicherheitsschraube	Tornillo Vis		
8	5100011341	7	Tie cable Kabelbinder	Fijación Attache		
9	5100009683	1	Cable harness Kabelbaum	Mazo de cables Harnais de câbles		
10	5100010865	1	battery boost cable Fremdstarterkabel	Cable Câble		
11	5100025321	1	Positive pole strap Plus-Pol-Leitung	Cable polo positivo Ligne borne positive		
12	5100010866	1	Negative pole strap Minus-Pol-Leitung	Cable polo negativo Ligne borne négative		
13	0047388	1	Cable yarn Kabelbinder	Fijación de cables Attache de câble		
14	5100009601	1	Bush Buchse	Buje Boîte		
15	5100011308	1	Compression spring Druckfeder	Resorte de compresión Ressort de pression	1x17,5x100x8,5	
16	0013574	1	Cheese head screw Zylinderschraube	Tornillo cilíndrico Vis à tête cylindrique	25Nm/18ft.lbs	

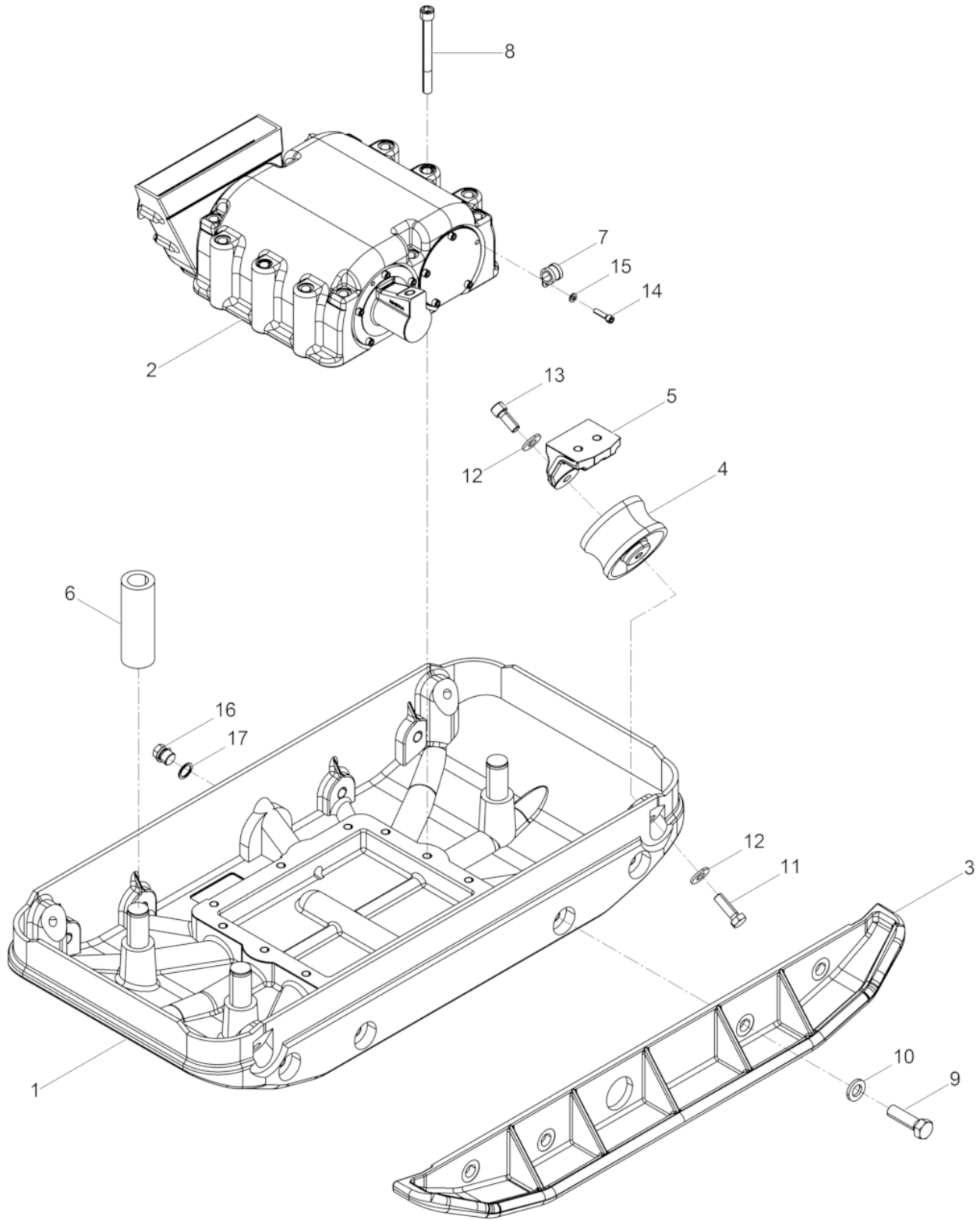

Ref. Pos.	Part No. Artikel Nr.	Qty. St.	Description Beschreibung	Descripción Description	Measurement./Abm.	Norm
					Torque/Drehm.	Sealant Schmierstoff
1	0102356	1	Baseplate Untermasse	Masa inferior Masse inferieure		
2	0220087	1	Exciter cpl. Erreger kpl.	Excitador cpl. Excitateur cpl.		
3	0044442	2	Extension plate Anbauplatte	Placa de extensión Elargisseur	8 cm	
4	2004814	4	Shockmount Gimetall-Kerblager mit Bund	Amortiguador Silentbloc	100 x 58	
5	0102105	4	Support Pufferbock	Soporte tope Support d'amortisseur		
6	0034442	3	Bushing Dämpfungsbuchse	Buje Douille		
7	0017123	1	Pipe clamp Rohrschelle	Abrazadera Collier pour tuyau		
8	0094518	12	Cheese head screw Zylinderschraube	Tornillo cilíndrico Vis à tête cylindrique	M12 x 120 120Nm/89ft.lbs	ISO4762
9	0039191	8	Hexagonal head cap screw Sechskantschraube	Tornillo hexagonal Vis à tête hexagonale	M16 x 1,5 x 55 210Nm/155ft.lbs	DIN961
10	0021988	8	Lock washer Sicherheitsscheibe	Arandela de seguridad Rondelle d'arrêt	HS16	
11	0011421	4	Hexagonal head cap screw Sechskantschraube	Tornillo hexagonal Vis à tête hexagonale	M12 x 40 86Nm/63ft.lbs	DIN933
12	0031565	8	Lockwasher Spannscheibe	Arandela elástica Rondelle de ressort	12	DIN6796
13	0011529	1	Cheese head screw Zylinderschraube	Tornillo cilíndrico Vis à tête cylindrique	M12 x 30 86Nm/63ft.lbs	ISO4762
14	0011550	1	Cheese head screw Zylinderschraube	Tornillo cilíndrico Vis à tête cylindrique	M6 x 25 10Nm/7ft.lbs	ISO4762
15	0010624	1	Flat washer Scheibe	Arandela Rondelle		
16	0068222	1	Plug (threaded) Verschlußschraube	Tapón roscado Bouchon		
17	0019156	1	Gasket Dichtring	Anillo de junta Bague d'étanchéité		

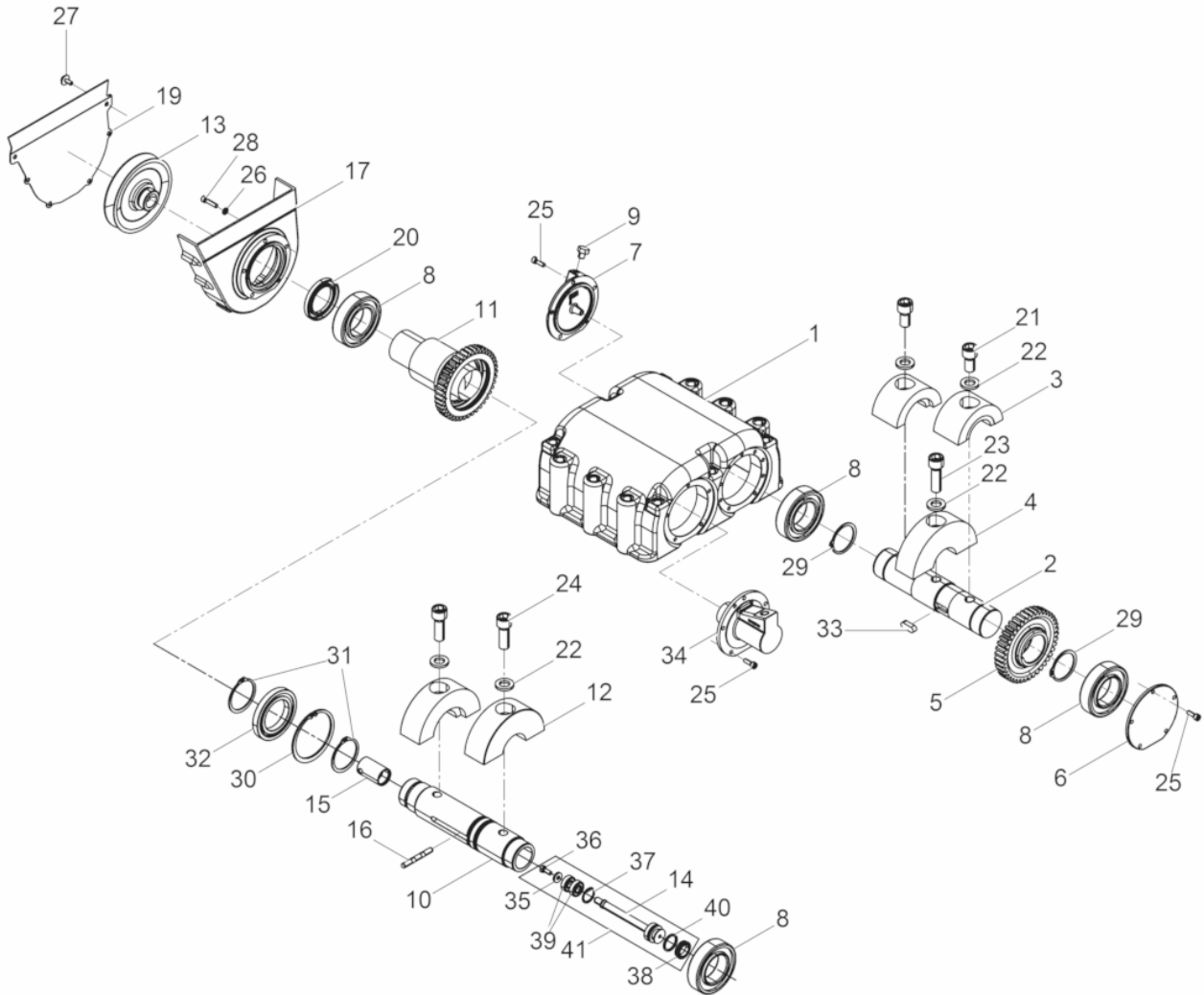

Ref. Pos.	Part No. Artikel Nr.	Qty. St.	Description Beschreibung	Descripción Description	Measurement./Abm.	Norm
					Torque/Drehm.	Sealant Schmierstoff
1	0099059	1	Exciter housing Erregergehäuse	Carcasa del excitador Carter excitateur		
2	0220059	1	Shaft Welle	Árbol Arbre		
3	0220082	2	Eccentric weight Unwucht	Masa excéntrica Balourd		
4	0220085	1	Eccentric weight Unwucht	Masa excéntrica Balourd		
5	0039116	1	Gear wheel Zahnrad	Engranaje Roue dentée		
6	0039110	1	Cover Deckel	Tapa Couvercle		
7	0102144	1	Vent cover Belüftungsdeckel	Tapa de ventilación Couvercle d'aération		
8	0103469	4	Cylindrical roller bearing Zylinderrollenlager	Rodamiento cilíndricos Roulement à rouleaux		
9	1103030	1	Vent screw Entlüftungsschraube	Tornillo de purga Vis d'évacuation d'air		
10	0220077	1	Shaft Welle	Árbol Arbre		
11	0220053	1	Adjusting sleeve Verstellhülse	Husillo de regulación Douille de réglage		
12	0220086	2	Eccentric weight Unwucht	Masa excéntrica Balourd		
13	0129844	1	V-belt pulley Keilriemenscheibe	Polea en V Poulie à courroie		
14	0220079	1	Bolt Bolzen	Perno Boulon		
15	0220106	1	Indexing bolt Schaltbolzen	Perno fijador Boulon		
16	0043382	1	Tripping pin Schaltstift	Espiga de mando Broche de manoeuvre		
17	0102724	1	Belt guard Riemenschutz	Protección de la polea Protection de courroie		
19	0102721	1	Cover plate Abdeckblech	Cubierta de chapa Tôle de recouvrement		
20	0048854	1	Rotary shaft seal Wellendichtring	Anillo de retén radial Bague d'étanchéité	48 x 72 x 7,4	
21	0044634	2	Cheese head screw Zylinderschraube	Tornillo cilíndrico Vis à tête cylindrique	M16 x 30 295Nm/218ft.lbs	ISO4762
22	0021988	5	Lock washer Sicherungsscheibe	Arandela de seguridad Rondelle d'arrêt	HS16	
23	0043812	1	Cheese head screw Zylinderschraube	Tornillo cilíndrico Vis à tête cylindrique	M16 x 50 295Nm/218ft.lbs	ISO4762
24	0126300	2	Cheese head screw Zylinderschraube	Tornillo cilíndrico Vis à tête cylindrique	M16 x 45 295Nm/218ft.lbs	ISO4762
25	0011552	14	Cheese head screw Zylinderschraube	Tornillo cilíndrico Vis à tête cylindrique	M6 x 18 10Nm/7ft.lbs	ISO4762
26	0010624	5	Flat washer Scheibe	Arandela Rondelle		

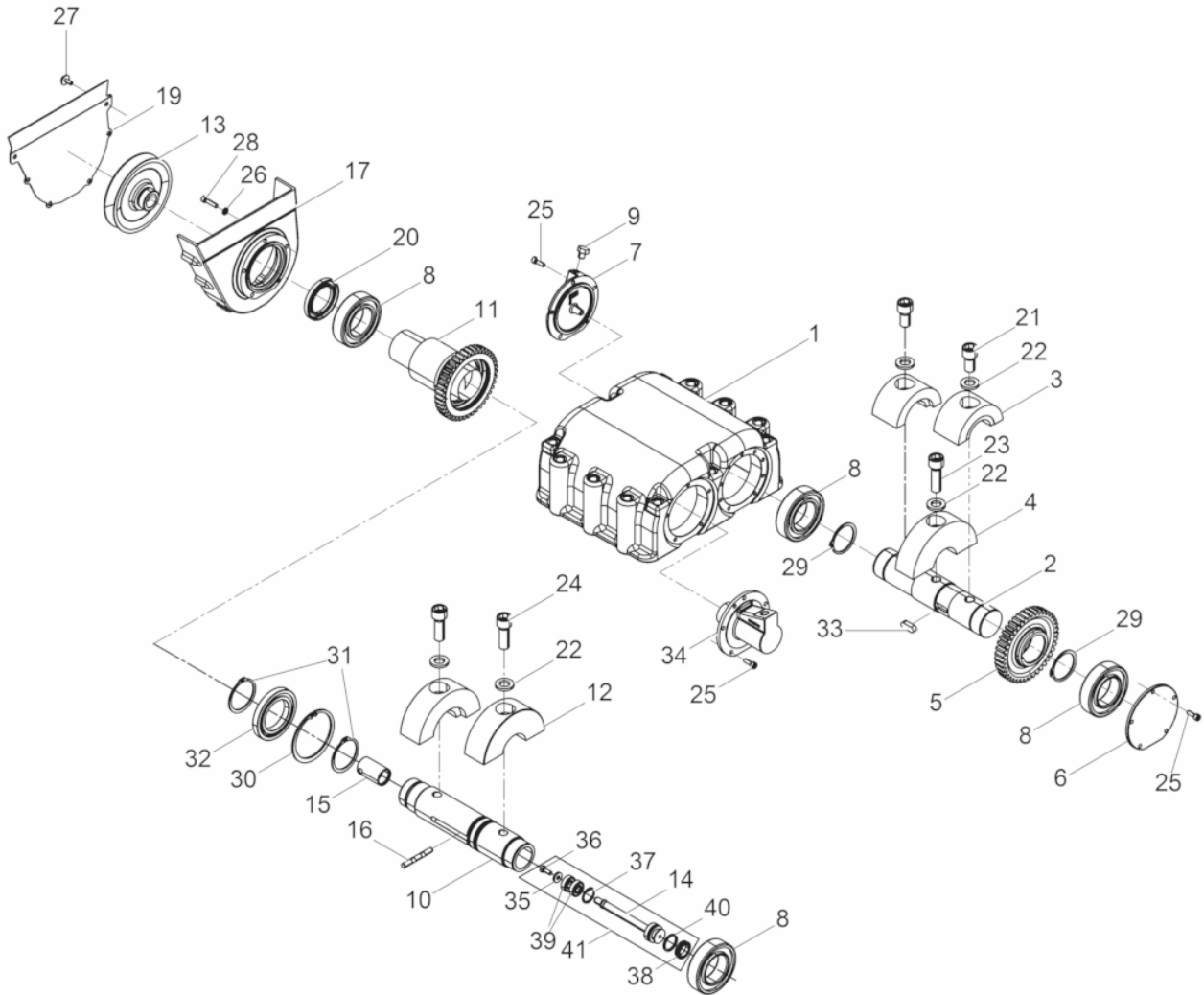

Ref. Pos.	Part No. Artikel Nr.	Qty. St.	Description Beschreibung	Descripción Description	Measurement./Abm.	Norm
					Torque/Drehm.	Sealant Schmierstoff
27	5100009501	6	Screw Kombi-Schraube	Tornillo Vis	M6 x 16 10Nm/7ft.lbs	
28	0011550	5	Cheese head screw Zylinderschraube	Tornillo cilíndrico Vis à tête cylindrique	M6 x 25 10Nm/7ft.lbs	ISO4762
29	2006113	2	Retaining ring Sicherungsring	Anillo de retención Bague d'arrêt		
30	2007057	1	Retaining ring Sicherungsring	Anillo de retención Bague d'arrêt	90 x 3	DIN472
31	2004822	2	Retaining ring Sicherungsring	Anillo de retención Bague d'arrêt	55 x 2	DIN471
32	0220133	1	Grooved ball bearing Rillenkugellager	Rodamiento a bolas Roulement rainuré à billes		DIN625
33	2001399	1	Fitting key Passfeder	Chaveta Clavette	A10 x 8 x 28	DIN6885
34	0048604	1	Cylinder cover Zylinderdeckel	Tapa del cilindro Couvercle de cylindre		
35	0124717	1	Washer Scheibe	Arandela Rondelle		
36	0014663	1	Hexagonal head cap screw Sechskantschraube	Tornillo hexagonal Vis à tête hexagonale	M6 x 16 10Nm/7ft.lbs	DIN933
37	0220384	1	Retaining ring Sicherungsring	Anillo de retención Bague d'arrêt	26x 1,20	DIN472
38	0043203	1	Lip seal ring Gummilippenring	Reten labial de goma Bague en caoutchouc	30 x 20 x 6	
39	0220383	2	Grooved ball bearing Rillenkugellager	Rodamiento a bolas Roulement rainuré à billes		DIN625
40	2006991	1	O-ring O-Ring	Anillo-O Bague-O	24 x 3	
41	0220081	1	Bolt cpl. Bolzen kpl.	Perno cpl. Boulon cpl.		

Center Pole cpl.
Deichsel kpl.
Barra de mando cpl.
Timon cpl.

DPU5545Heh

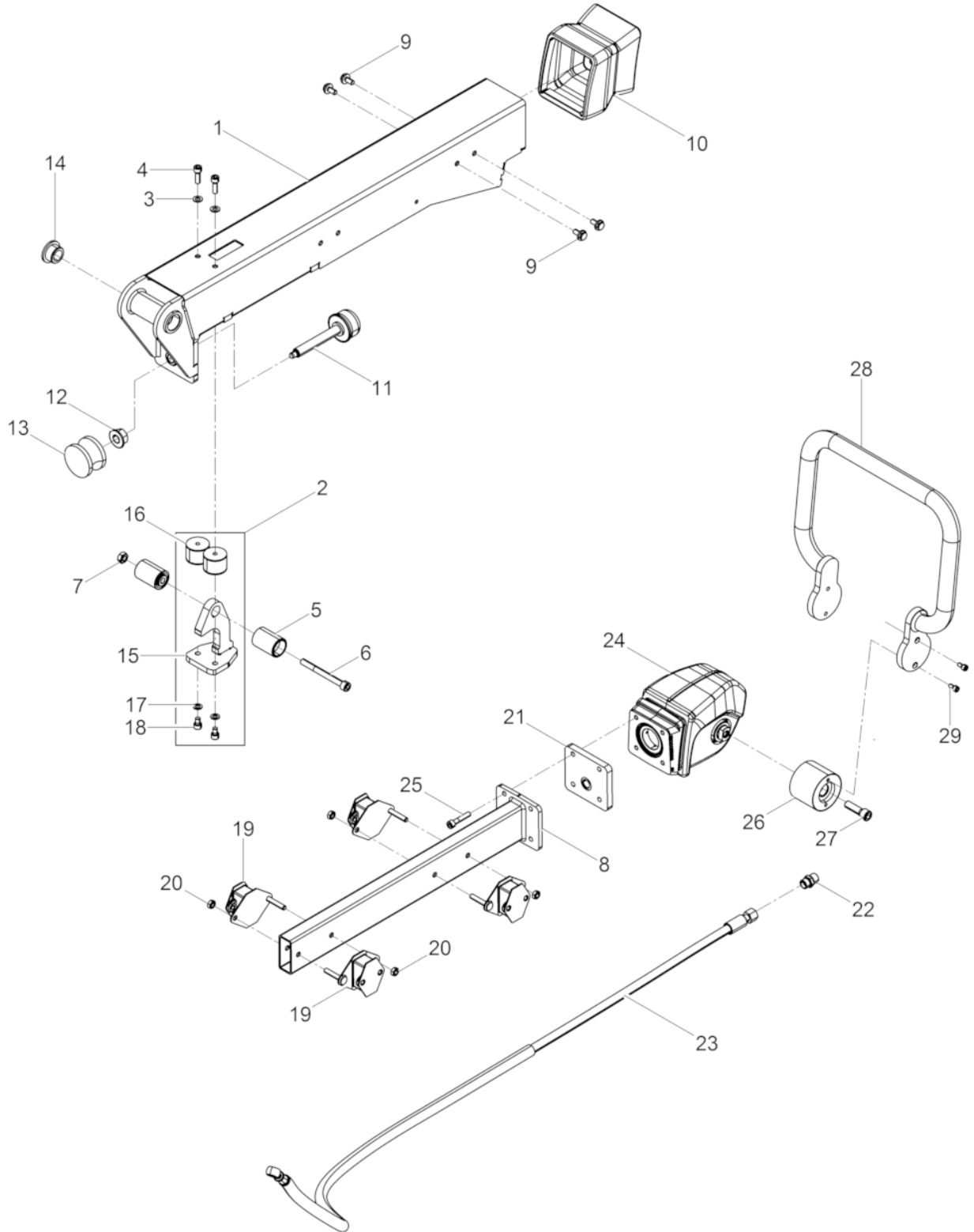

Ref. Pos.	Part No. Artikel Nr.	Qty. St.	Description Beschreibung	Descripción Description	Measurem./Abm.	Norm
					Torque/Drehm.	Sealant Schmierstoff
1	5100009952	1	Center Pole tube Deichselrohr	Barra de mando tubo Timon tube		
2	5100005543	1	Lock Arretierung	Dispositivo de retención Dispositif d'arrêt		
3	0010622	2	Flat washer Scheibe	Arandela Rondelle		
4	0013574	2	Cheese head screw Zylinderschraube	Tornillo cilíndrico Vis à tête cylindrique		
5	5100002007	2	Retaining Handle Arretierungsgriff	Empuñadura de Retención Poignée D'Arrêt		
6	0037090	1	Cheese head screw Zylinderschraube	Tornillo cilíndrico Vis à tête cylindrique	M10 x 100 49Nm/36ft.lbs	ISO4762
7	0010883	1	Hexagon nut Sechskantmutter	Tuerca hexagonal Écrou hexagonal		
8	5100005106	1	square tube cpl. Vierkantrohr kpl.	tubo cuadrado cpl. Tube carré cpl.		
9	0211795	8	corrugated-head screw Sicherheitsschraube	Tornillo Vis		
10	5100005538	1	Bellows Faltenbalg	Fuelle acordeón Soufflet		
11	0043928	1	Threaded spindle cpl. Gewindespindel kpl.	Husillo roscado cpl. Tige fileté cpl.		
12	0202866	1	Locknut Sechskantmutter	Contratuerca Contre-écrou	M16	EN1661
13	0043233	1	Shockmount Gummi-Metall-Kerbpuffer	Tope caucho-metal Tampon métallique oscillant	60 x 40	
14	5100004367	2	Bush Buchse	Buje Boîte		
15	5100005541	1	Lock Arretierung	Dispositivo de retención Dispositif d'arrêt		
16	0129818	2	Shockmount Gummi-Metall-Puffer	Tope caucho-metal Tampon métallique oscillant		
17	0010742	2	Washer Scheibe	Arandela Rondelle		
18	0011543	2	Socket head screw Zylinderschraube	Tornillo hueco Vis à six-pans creux	M8 x 20 24Nm/18ft.lbs	ISO4762
19	5100010497	4	Shockmount Gummipuffer	Tope caucho-metal Tampon oscillant		
20	0010882	4	Hexagon nut Sechskantmutter	Tuerca hexagonal Écrou hexagonal		
21	5100005526	1	Flange Flansch	Brida Bride		
22	0069225	1	Screwed socket Einschraubstutzen	Empalme roscado Manchon visse		
23	5100005553	1	Hose pipe Schlauchleitung	Conducto flexible Conduite flexible		
24	5100027083	1	Center Pole Head cpl. Deichselkopf kpl.	Cabezal de mando cpl. Tête de timon cpl.		
25	0011539	4	Cheese head screw Zylinderschraube	Tornillo cilíndrico Vis à tête cylindrique	M8 x 40 25Nm/18ft.lbs	ISO4762

Center Pole cpl.
Deichsel kpl.
Barra de mando cpl.
Timon cpl.

DPU5545Heh

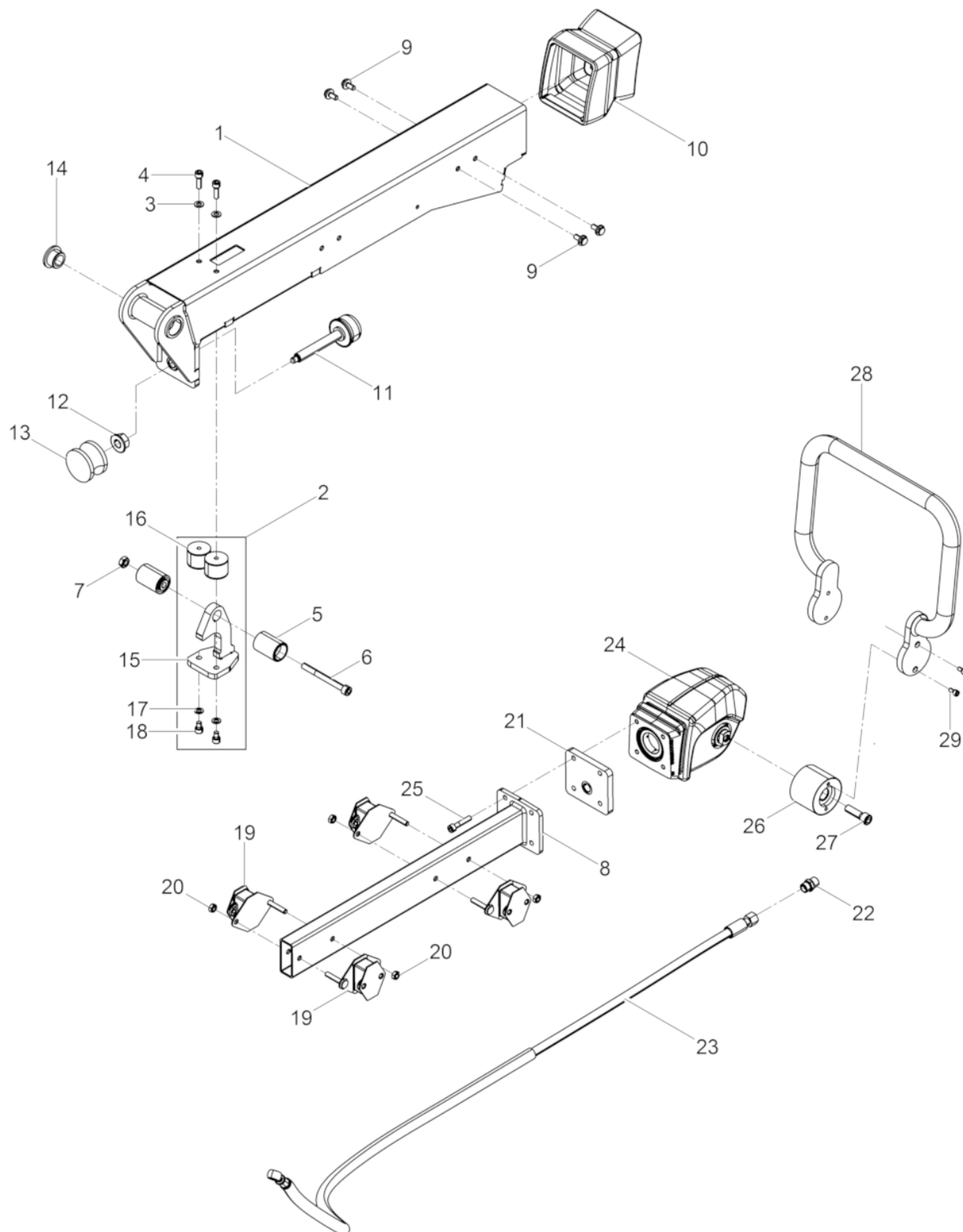

Ref. Pos.	Part No. Artikel Nr.	Qty. St.	Description Beschreibung	Descripción Description	Measurement./Abm.	Norm
					Torque/Drehm.	Sealant Schmierstoff
26	0215035	2	Shockmount Gummi-Metall-Puffer	Tope caucho-metal Tampon metallique oscillant		
27	0011527	2	Cheese head screw Zylinderschraube	Tornillo cilíndrico Vis à tête cylindrique		
28	5100005124	1	Clamp Bügel	Abrazadera Attache		
29	0011554	4	Cheese head screw Zylinderschraube	Tornillo cilíndrico Vis à tête cylindrique		

Center Pole Head cpl.
Deichselkopf kpl.
Cabezal de mando cpl.
Tête de timon cpl.

DPU5545Heh

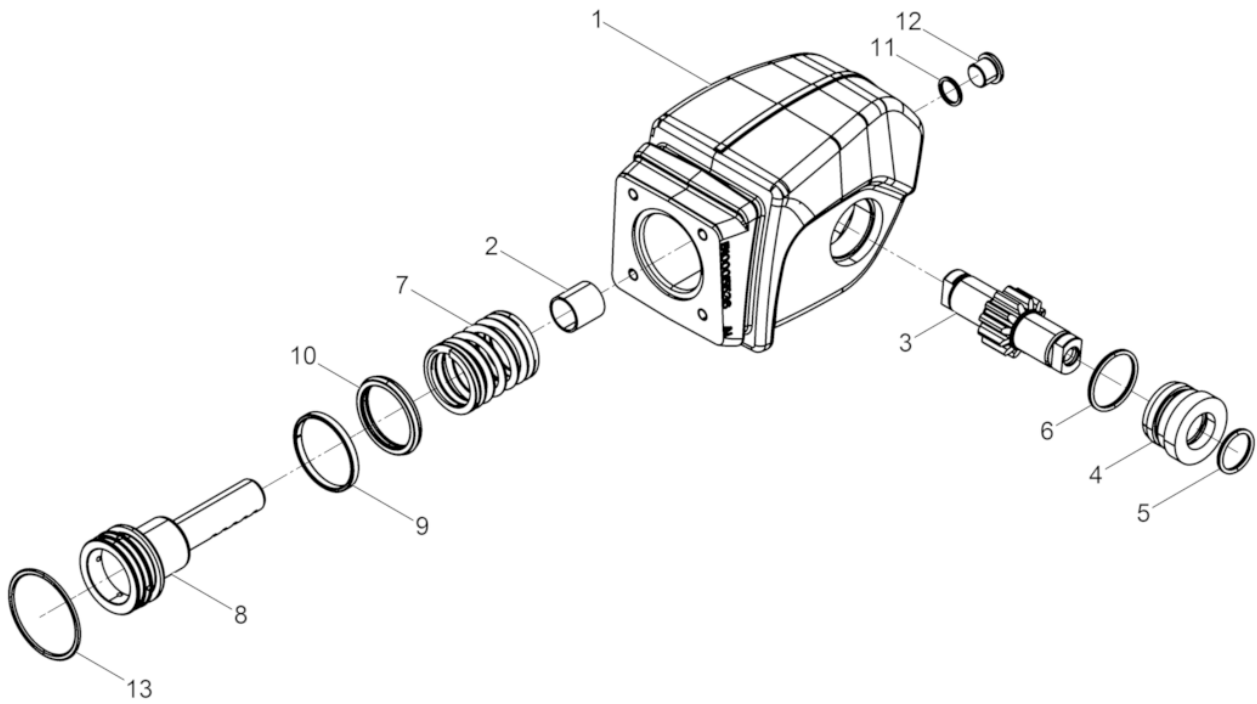

Ref. Pos.	Part No. Artikel Nr.	Qty. St.	Description Beschreibung	Descripción Description	Measurement./Abm.	Norm
					Torque/Drehm.	Sealant Schmierstoff
1	5100005537	1	Center pole head Deichselkopf	Cabezal de barra Tête de timon		
2	0126164	1	Slide bush Gleitbuchse	Buje deslizante Bôte de glissement		
3	0069726	1	Long face pinion Zahnradwelle	Eje de rueda dentada Arbre formant pignon		
4	0125926	2	Spacer Distanzstück	Pieza distanciadora Pièce d'écartement		
5	0018194	2	O-ring O-Ring	Anillo-O Bague-O		
6	0068752	2	O-ring O-Ring	Anillo-O Bague-O		
7	5100005559	1	Compression spring Druckfeder	Resorte de compresión Ressort de pression		
8	5100005138	1	Control piston Steuerkolben	Pistón de mando Piston de commande		
9	5100005532	1	Guide Ring Führungsring	Anillo Guía Bague de Guidage	KB 55x50x5,5 HG517	
10	5100005533	1	Gasket Dichtung	Junta Joint		
11	0012082	1	Seal ring Dichtungsring	Anillo sellador Rondelle à étancher	A16 x 20	DIN7603
12	0011050	1	Plug (threaded) Verschlußschraube	Tapón roscado Bouchon	M16 x 1,5	DIN908
13	0039235	1	O-ring O-Ring	Anillo-O Bague-O	58 x 3	

Coupling cpl.
Kupplung kpl.
Embrague cpl.
Embrayage cpl.

DPU5545Heh

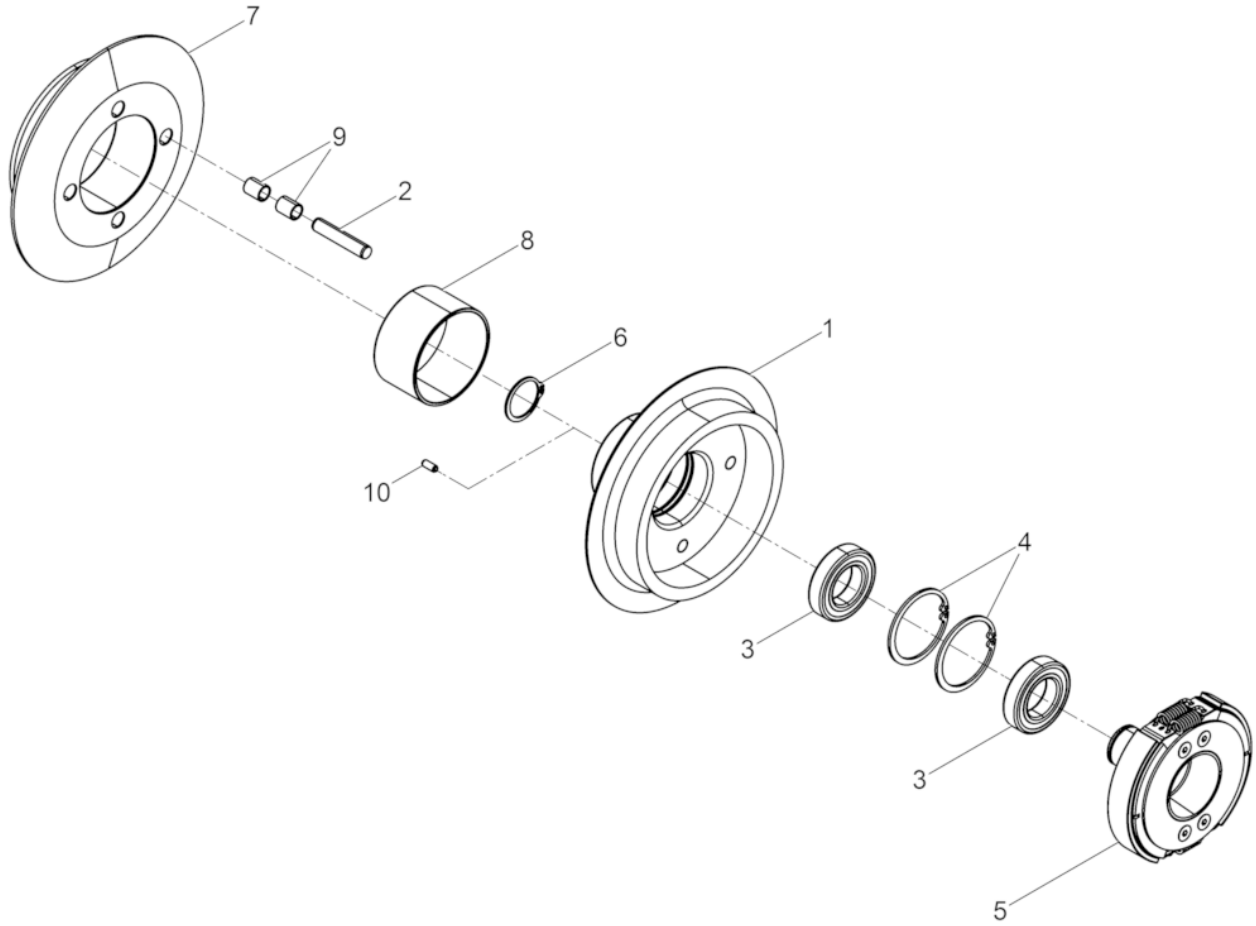

Ref. Pos.	Part No. Artikel Nr.	Qty. St.	Description Beschreibung	Descripción Description	Measurement./Abm.	Norm
					Torque/Drehm.	Sealant Schmierstoff
1	0058541	1	Clutch drum Kupplungsglocke	Campana del embrague Cloche de rentrée	49Nm/36ft.lbs	
2	0058539	4	Pin Stift	Espiga Goupille		
3	0039999	2	Grooved ball bearing Rillenkugellager	Rodamiento a bolas Roulement rainuré à billes		
4	2003826	2	Retaining ring Sicherungsring	Anillo de retención Bague d'arrêt	55 x 2	DIN472
5	0201992	1	Centrifugal Clutch Fliehkraftkupplung	Embrague Embrayage		
6	2001815	1	Retaining ring Sicherungsring	Anillo de retención Bague d'arrêt	30 x 1,5	DIN471
7	0058540	1	V-belt pulley Keilriemenscheibe	Polea en V Poulie à courroie		
8	0058536	1	Bushing Buchse	Buje Boîte	70 ID	
9	0058551	8	Bush Buchse	Casquillo Boîte	10 ID	
10	0013591	2	Spring pin Spannstift	Pasador de sujeción Goupille élastique	5 x 12	DIN1481

Centrifugal Clutch cpl.
Fliehkraftkupplung kpl.
Embrague centrifugo cpl.
Embrayage centrifuge cpl.

DPU5545Heh

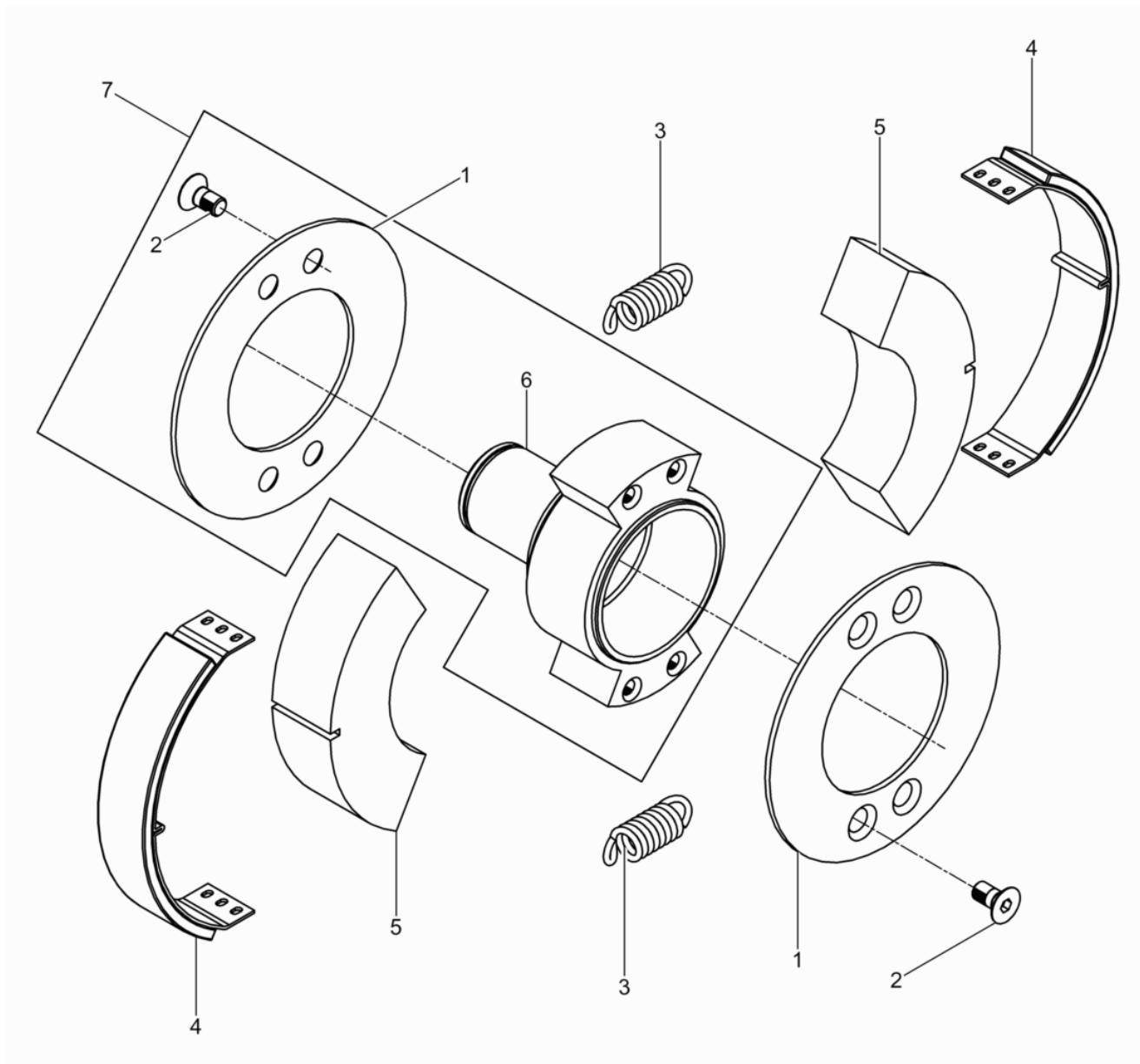

Ref. Pos.	Part No. Artikel Nr.	Qty. St.	Description Beschreibung	Descripción Description	Measurement./Abm.	Norm
					Torque/Drehm.	Sealant Schmierstoff
1	0201994	2	Fixing disc Fixierscheibe	Arandela de retención Rondelle de fixation		
2	0024338	8	Countersunk screw Senkschraube	Tornillo avellanado Vis noyée	M6 x 10	DIN963
3	0045979	4	Tension spring Zugfeder	Resorte de tracción Ressort de traction		
4	2006075	2	Lining Belagträger	Zapata Garniture d'embrayage		
5	0049506	2	Centrifugal weight Fliehkewicht	Peso centrifugo Poids centrifuge		
6	0201993	1	Hub Nabe	Cubo Moyeu		
7	0203003	1	Hub kit Nabensatz	Juego de cubo Jeu de moyeu		

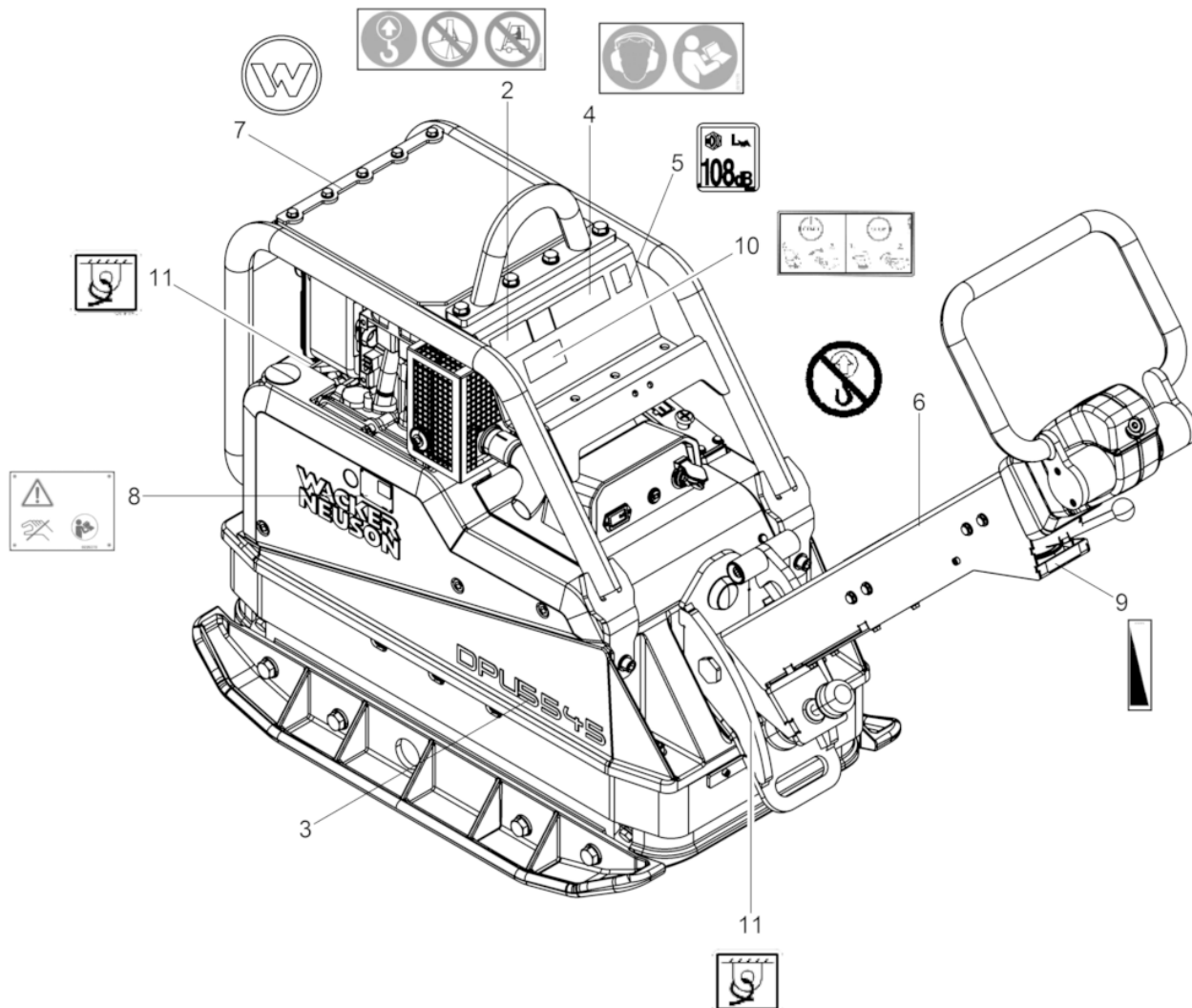

Ref. Pos.	Part No. Artikel Nr.	Qty. St.	Description Beschreibung	Descripción Description	Measurement./Abm.	Norm
					Torque/Drehm.	Sealant Schmierstoff
2	0216633	1	Instruction Label Aufkleber-Hinweis	Calcomanía-Indicación Autocollant avec Indication		
3	0220391	2	Type Label Aufkleber-Typ	Tipo etiqueta autoadhesiva Autocollant de type		
4	0219175	1	Labels Aufkleber	Calcomanias Autocollants		
5	0129784	1	Decal-sound power level Aufkleber-Schallleistungspegel	Etiqueta autoadhesiva-nivel de potencia acústica Autocollante-niveau sonore		
6	0220000	1	Instruction Label Aufkleber-Warnhinweis	Calcomanía-Indicación Autocollant avec Indication		
7	0222085	1	Label Symbol Aufkleber Symbol	Calcomanía Símbolo Autocollant Symbole		
8	0226378	1	Information sign Hinweisschild	Placa indicadora Plaque		
11	0219259	1	Labels Aufkleber	Calcomanias Autocollants		
12	5100026807	1	Labels (Start Stop) Aufkleber (Start Stop)	Calcomanias (Start Stop) Autocollants (Start Stop)		
13	1000184310	3	Label Aufkleber	Calcomanía Autocollant		

Vibration Plate
 Vibrationsplatte
 Plancha Vibradora
 Plaque Vibrante

DPU5545Heh

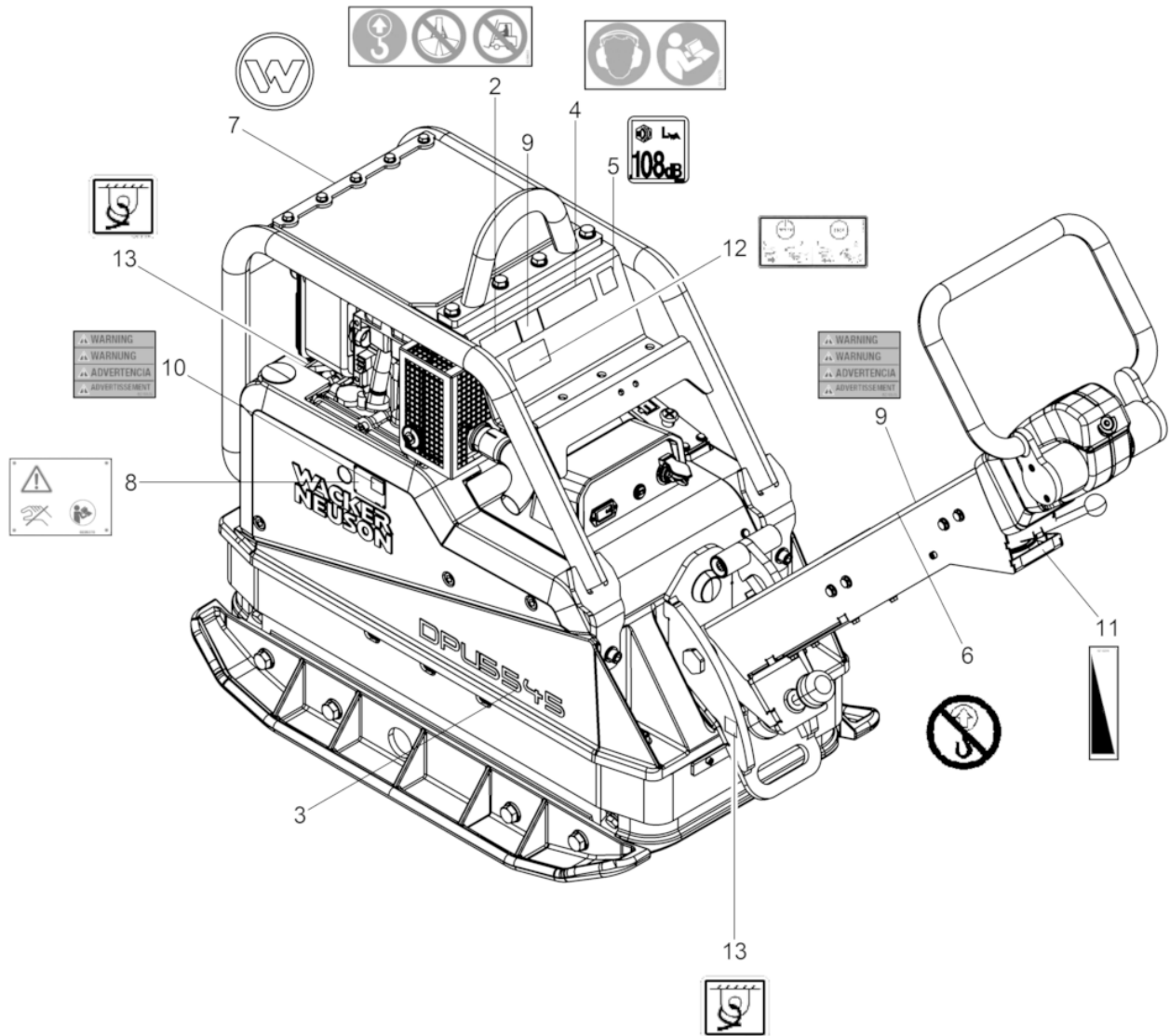

Ref. Pos.	Part No. Artikel Nr.	Qty. St.	Description Beschreibung	Descripción Description	Measurement./Abm.	Norm
					Torque/Drehm.	Sealant Schmierstoff
2	0216633	1	Instruction Label Aufkleber-Hinweis	Calcomanía-Indicación Autocollant avec Indication		
3	0220391	2	Type Label Aufkleber-Typ	Tipo etiqueta autoadhesiva Autocollant de type		
4	0219175	1	Labels Aufkleber	Calcomanías Autocollants		
5	0129784	1	Decal-sound power level Aufkleber-Schalleistungspegel	Etiqueta autoadhesiva-nivel de potencia acústica Autocollante-niveau sonore		
6	0220000	1	Instruction Label Aufkleber-Warnhinweis	Calcomanía-Indicación Autocollant avec Indication		
7	0222085	1	Label Symbol Aufkleber Symbol	Calcomanía Símbolo Autocollant Symbole		
8	0226378	1	Information sign Hinweisschild	Placa indicadora Plaque		
9	0219176	2	Labels Aufkleber	Calcomanías Autocollants		
10	0219081	1	Labels Aufkleber	Calcomanías Autocollants		
11	0219259	1	Labels Aufkleber	Calcomanías Autocollants		
12	5100026807	1	Labels (Start Stop) Aufkleber (Start Stop)	Calcomanías (Start Stop) Autocollants (Start Stop)		
13	1000184310	3	Label Aufkleber	Calcomanía Autocollant		



**WACKER
NEUSON**

**Engine
Motor
Motor
Moteur**

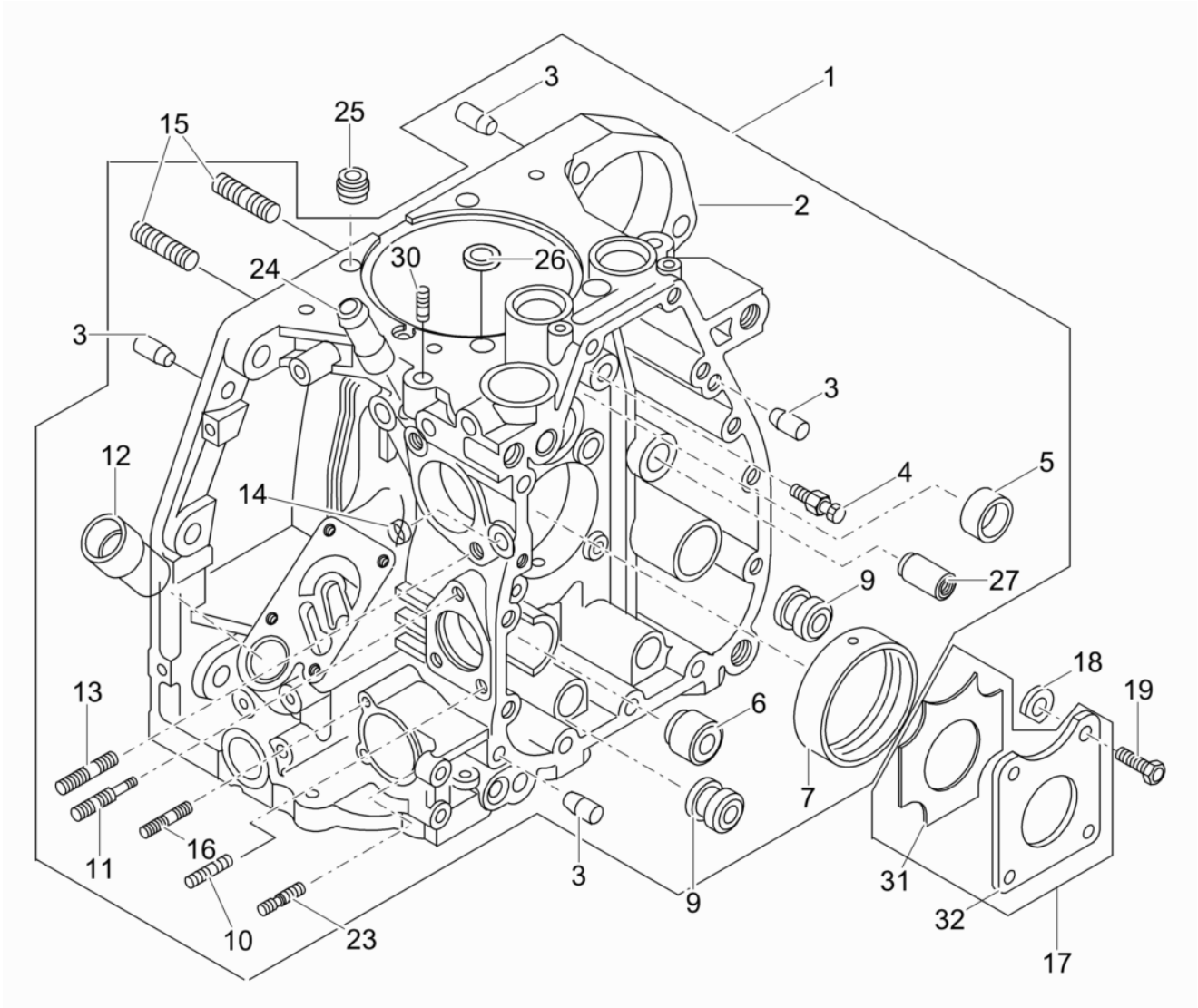

Ref. Pos.	Part No. Artikel Nr.	Qty. St.	Description Beschreibung	Descripción Description	Measurem./Abm.	Norm
					Torque/Drehm.	Sealant Schmierstoff
1	0207773	1	Crankcase Kurbelgehäuse	Cárter Carter		
3	0207615	4	Straight pin Zylinderstift	Pasador cilíndrico Goupille cylindrique	8x20	
4	0104392	1	Grease jet Schmierdüse	Gicleur de lubricación Gicleur graisseur		
5	0226589	1	Bearing bush Lagerbuchse	Casquillo del cojinete Boîte de roulement		
6	0202384	1	Push-in plug Stopfen	Tapón Bouchon		
7	0104393	1	Slide bearing Gleitlager	Cojinete deslizante Roulement de glissement		
8	0106637	1	Slide bearing Gleitlager	Cojinete deslizante Roulement de glissement	-0,5	
9	0202386	2	Push-in plug Stopfen	Tapón Bouchon		
10	0202433	2	Threaded bolt Gewindebolzen	Perno roscado Boulon fileté	M6 x 16	
11	0094925	1	Stud bolt Stiftschraube	Perno prisionero Boulon		
12	0099415	1	Oil fill tube Einfüllstutzen	Tubo llenador de aceite Tube-remplisseur d'huile		
13	0226600	2	Stud Stiftschraube	Perno prisionero Boulon	M8x25	
14	0202447	1	Washer Scheibe	Arandela Rondelle	A3C	
15	0226601	8	Stud Stiftschraube	Perno prisionero Boulon	M8x22	
16	0099414	2	Stud Stiftschraube	Perno prisionero Boulon	M6 x 22	
17	0098453	1	Check disc Anlaufscheibe	Arandela tope Disque		
18	0098455	4	Washer Scheibe	Arandela Rondelle	1,05	
18	0098454	4	Washer Scheibe	Arandela Rondelle	1,2	
19	0098456	4	Hexagonal head cap screw Sechskantschraube	Tornillo hexagonal Vis à tête hexagonale		
23	0099414	1	Stud Stiftschraube	Perno prisionero Boulon	M6 x 22	
25	0126919	2	Rubber ring Gummiring	Anillo de goma Bague en caoutchouc		
26	0104397	2	Rubber ring Gummiring	Anillo de goma Bague en caoutchouc		
27	0202406	1	Bush Buchse	Buje Boîte		
30	0107775	1	Bushing Buchse	Buje Douille		

Crankcase cpl.
Kurbelgehäuse kpl.
Cárter cpl.
Carter cpl.

DPU5545Heh

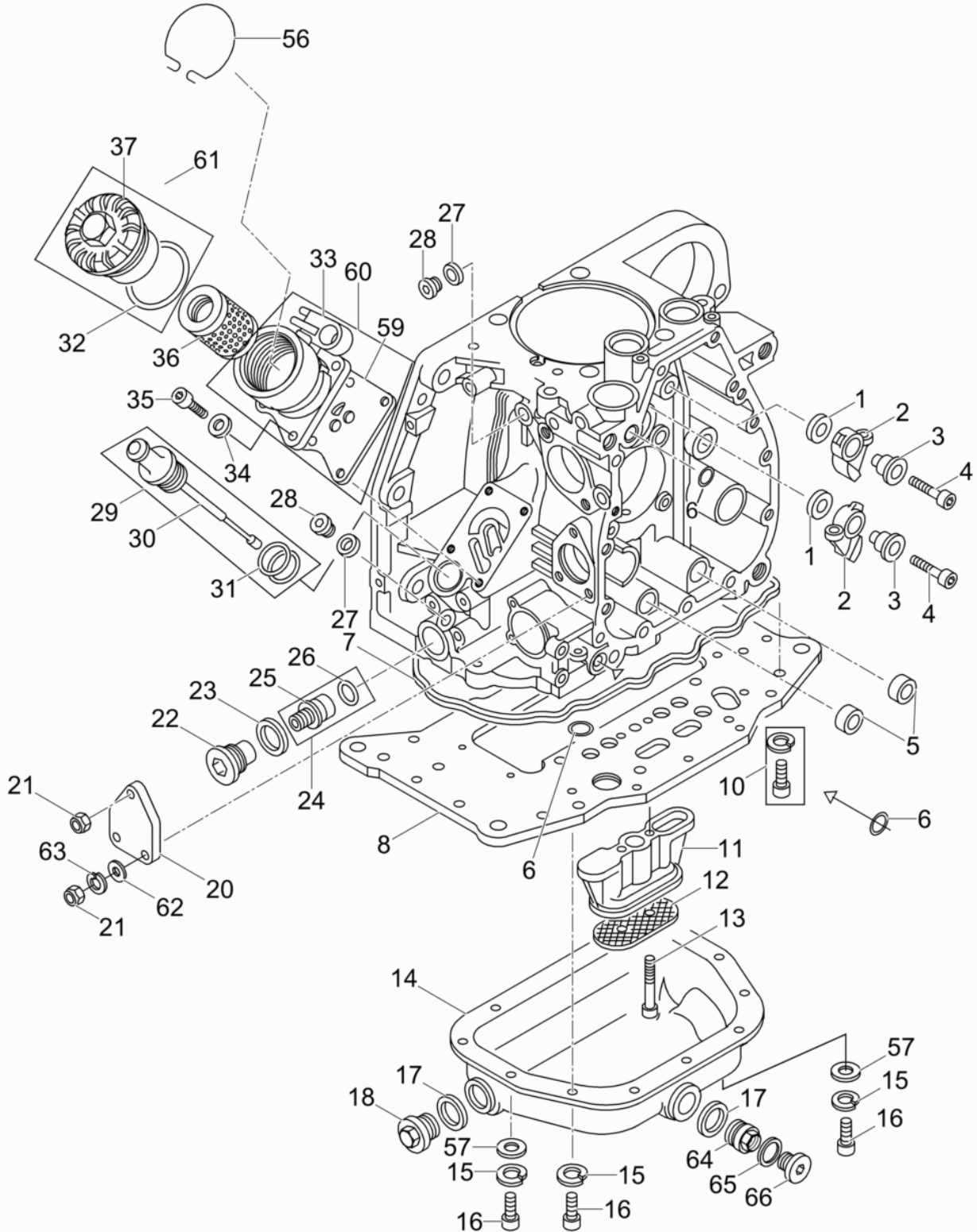

Ref. Pos.	Part No. Artikel Nr.	Qty. St.	Description Beschreibung	Descripción Description	Measur./Abm.	Norm
					Torque/Drehm.	Sealant Schmierstoff
1	0104365	2	Washer Scheibe	Arandela Rondelle	10.1 x 22 x 3	
2	0094937	2	Sliding lever Schlepphebel	Palanca deslizante Levier glissant		
3	0094936	2	Cam follower spindle shaft Buchse	Rodillo de leva Contre-came		
4	0217112	2	Cheese head screw Zylinderschraube	Tornillo cilíndrico Vis à tête cylindrique	M6 x 30	
5	0094935	2	Washer Flachdichtring	Arandela Rondelle		
6	0094934	3	O-Ring O-Ring	Anillo-O Joint torique	9,5 x 2,5	
7	0094952	1	Gasket Dichtung	Junta Joint		
8	0104403	1	Plate Platte	Placa Plaque		
10	0202463	22	Hexagon socket head screw Innensechskantschraube	Tornillo a seis lados huecos Vis à six pans creux	M8 x 25	
11	0104404	1	Suction housing Sauggehäuse	Carcasa de aspiración Carter d'aspiration		
12	0094955	1	Strainer Sieb	Tamizador Tamis		
13	0202423	2	Screw Schraube	Tornillo Vis	M6 x 30	
14	0104405	1	Oil pan Ölwanne	Carter de aceite Cuvette carter à huile		
15	0151456	12	Lock washer Federring	Arandela elástica Rondelle de ressort	6	DIN128
16	0202450	12	Hexagon socket head screw Innensechskantschraube	Tornillo a seis lados huecos Vis à six pans creux	M6 x 10	
17	0202416	2	Oil Seal Öldichtung	Junta de Aceite Joint D'Huile	52 x 80 x 10	
18	0094958	1	Plug (threaded) Verschlußschraube	Tapón roscado Bouchon	AM22 x 1,5	DIN7604
20	0207539	1	Cover Deckel	Tapa Couvercle		
21	0129021	3	Locknut Sechskantmutter	Contratuerca Contre-écrou	VM6	
22	0126921	1	Screw plug Verschlußschraube	Tornillo de cierre Vis de fermeture		
23	0094948	1	Gasket Dichtring	Anillo de junta Bague d'étanchéité	A24 x 29	DIN7603
24	0226586	1	Valve Ventil	Válvula Valve		
26	0126922	1	O-ring O-Ring	Anillo-O Bague-O	18 x 2	
27	0071121	2	Sealing ring Dichtungsring	Anillo sellante Bague d'étanchéité	A10 x 13,5	
28	0151213	2	Screw plug Verschlußschraube	Tornillo de cierre Vis de fermeture	M10 X 1	DIN908

Crankcase cpl.
Kurbelgehäuse kpl.
Cárter cpl.
Carter cpl.

DPU5545Heh

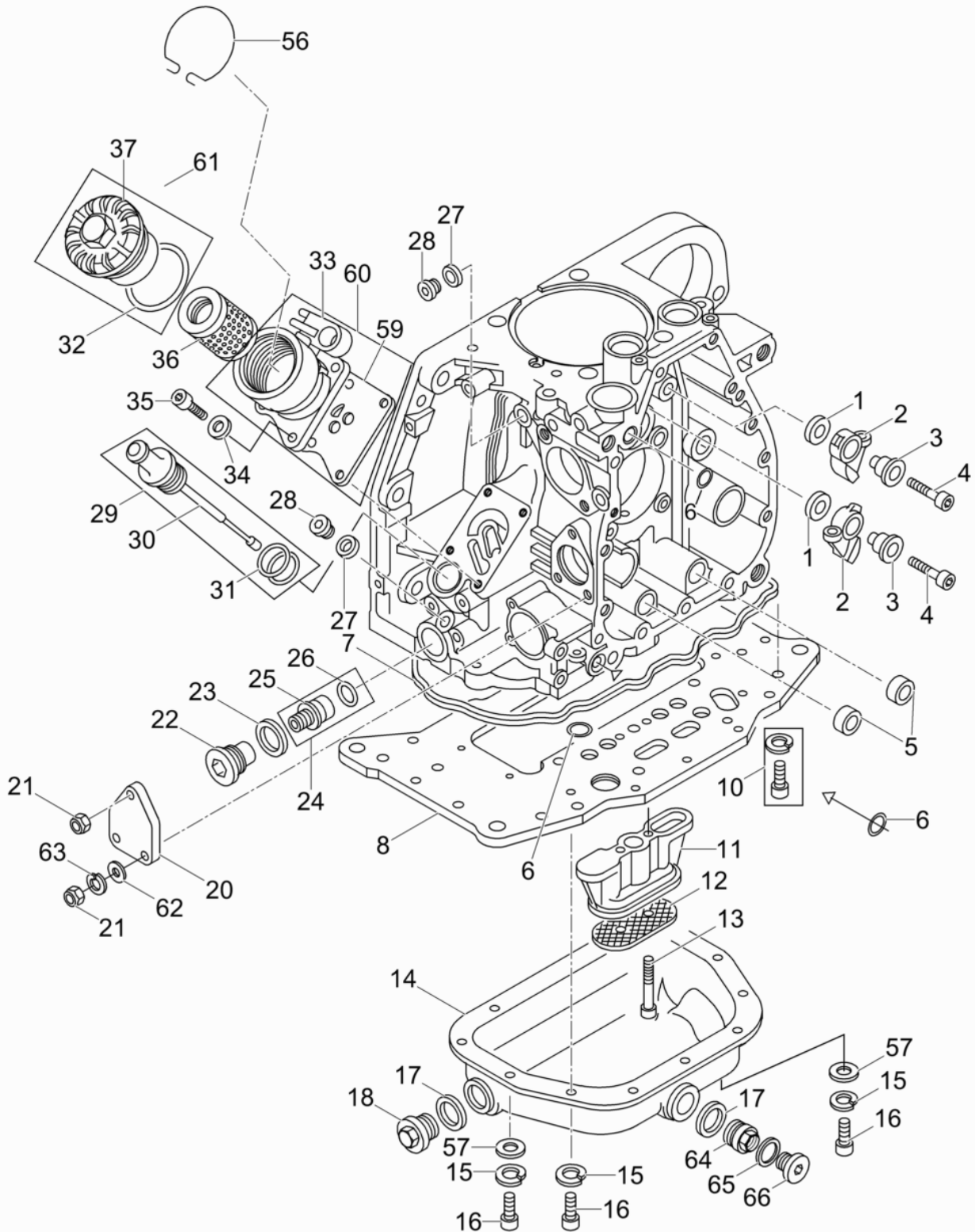

Ref. Pos.	Part No. Artikel Nr.	Qty. St.	Description Beschreibung	Descripción Description	Measurement./Abm.	Norm
					Torque/Drehm.	Sealant Schmierstoff
29	0104398	1	Dipstick Tauchstab	Varilla de inmersión Jauge		
31	0094933	2	O-Ring O-Ring	Anillo-O Joint torique		
32	0094928	1	Gasket Flachdichtring	Juntaaceite Joint		
34	0151290	4	Spring washer Federscheibe	Arandela elástica Rondelle à ressort	A6	DIN137
35	0202437	4	Cheese head screw Zylinderschraube	Tornillo cilíndrico Vis à tête cylindrique	M6 x 20	
36	0094930	1	Element Filterpatrone	Elemento Elément		
56	0104402	1	Spring Drahtfeder	Resorte Ressort		
57	0151324	2	Washer Scheibe	Arandela Rondelle	6.4	
59	0106559	1	Seal Dichtung	Junta Joint		
61	0094931	1	Cover Schraubdeckel	Tapa Couvercle		
62	0151324	2	Washer Scheibe	Arandela Rondelle	6.4	
63	0151456	2	Lock washer Federring	Arandela elástica Rondelle de ressort	6	DIN128
64	0104406	1	Screw plug Verschlusschraube	Tornillo de cierre Vis de fermeture		
65	0012624	1	Gasket Dichtring	Anillo de junta Bague d'étanchéité	A14 x 18	DIN7603
66	0207818	1	Screw Plug Verschlusschraube	Tapón Roscado Vis de Fermeture		

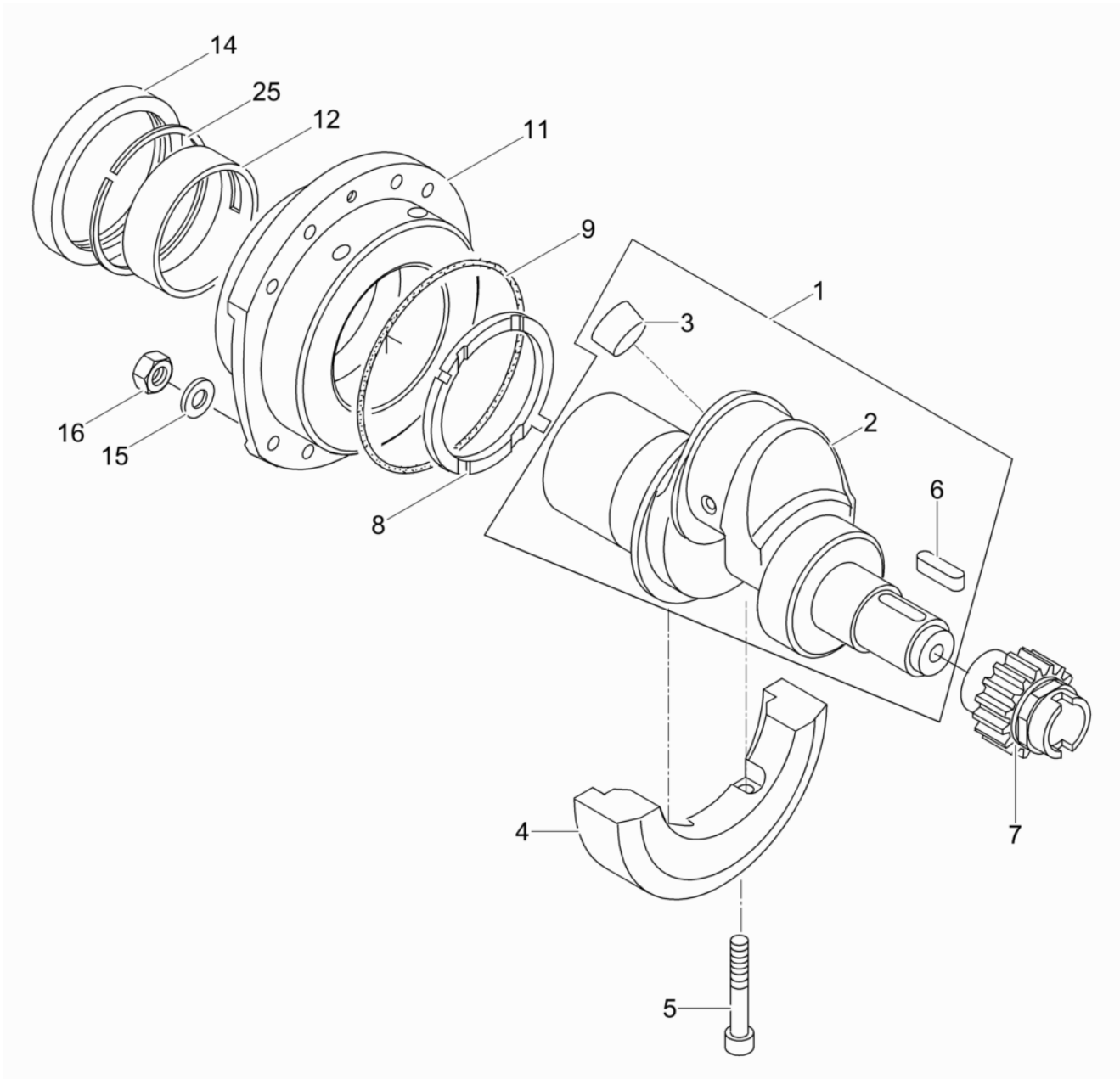

Ref. Pos.	Part No. Artikel Nr.	Qty. St.	Description Beschreibung	Descripción Description	Measurem./Abm.	Norm
					Torque/Drehm.	Sealant Schmierstoff
1	0226580	1	Crankshaft Kurbelwelle	Cigüeñal Vilebrequin		
3	0202451	1	Push-in plug Stopfen	Tapón Bouchon	22	
4	0207789	1	Counterweight Gegengewicht	Contrapeso Contre-poids		
5	0226596	2	Cheese head screw Zylinderschraube	Tornillo cilíndrico Vis à tête cylindrique	M8x40	
6	0094868	1	Fitting key Passfeder	Chaveta Clavette	A6 x 4 x 32	DIN6885
7	0106529	1	Pinion Ritzel	Piñón Pignon		
8	0104356	1	Protective plate Schleuderblech	Placa Plaque		
9	0104357	1	O-ring O-Ring	Anillo-O Bague-O		
11	0126914	1	Bearing flange cpl. Lagerflansch kpl.	Brida de cojinete cpl. Bride de roulement cpl.		
12	0104359	1	Slide bearing Gleitlager	Cojinete deslizante Roulement de glissement		
13	0106636	1	Slide bearing Gleitlager	Cojinete deslizante Roulement de glissement	-0,5	
14	0104360	1	Rotary shaft seal Wellendichtring	Anillo de retén radial Bague d'étanchéité		
15	0202460	8	Washer Scheibe	Arandela Rondelle	8,4	
16	0094876	8	Hexagon nut Sechskantmutter	Tuerca hexagonal Écrou hexagonal	M8	ISO4032
25	0125884	1	Retaining ring Sicherungsring	Anillo de retención Bague d'arrêt		

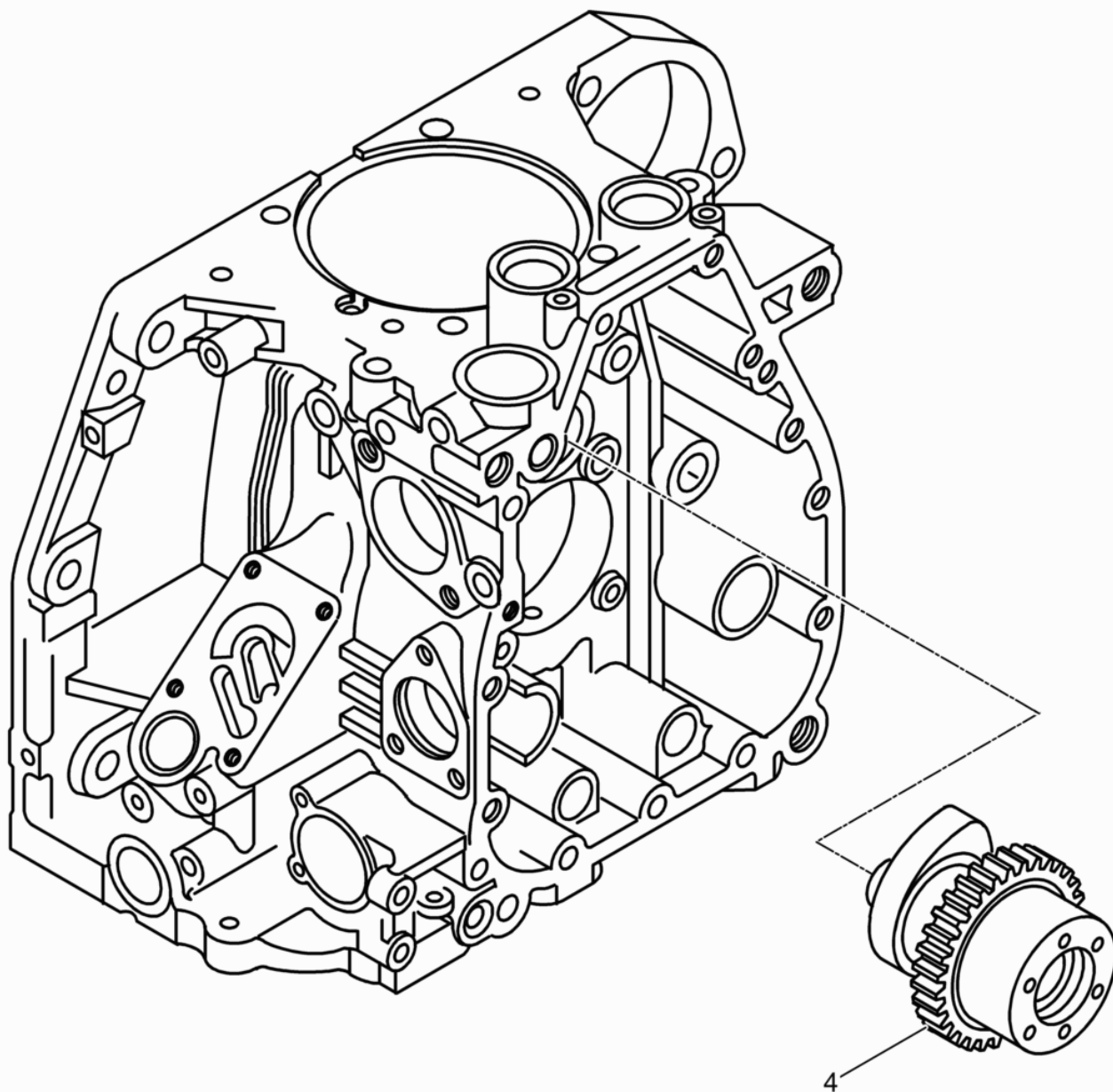

Ref. Pos.	Part No. Artikel Nr.	Qty. St.	Description Beschreibung	Descripción Description	Measurem./Abm.	Norm
					Torque/Drehm.	Sealant Schmierstoff
4	0226594	1	Camshaft Nockenwelle	Árbol de Levas Arbre à Cames		

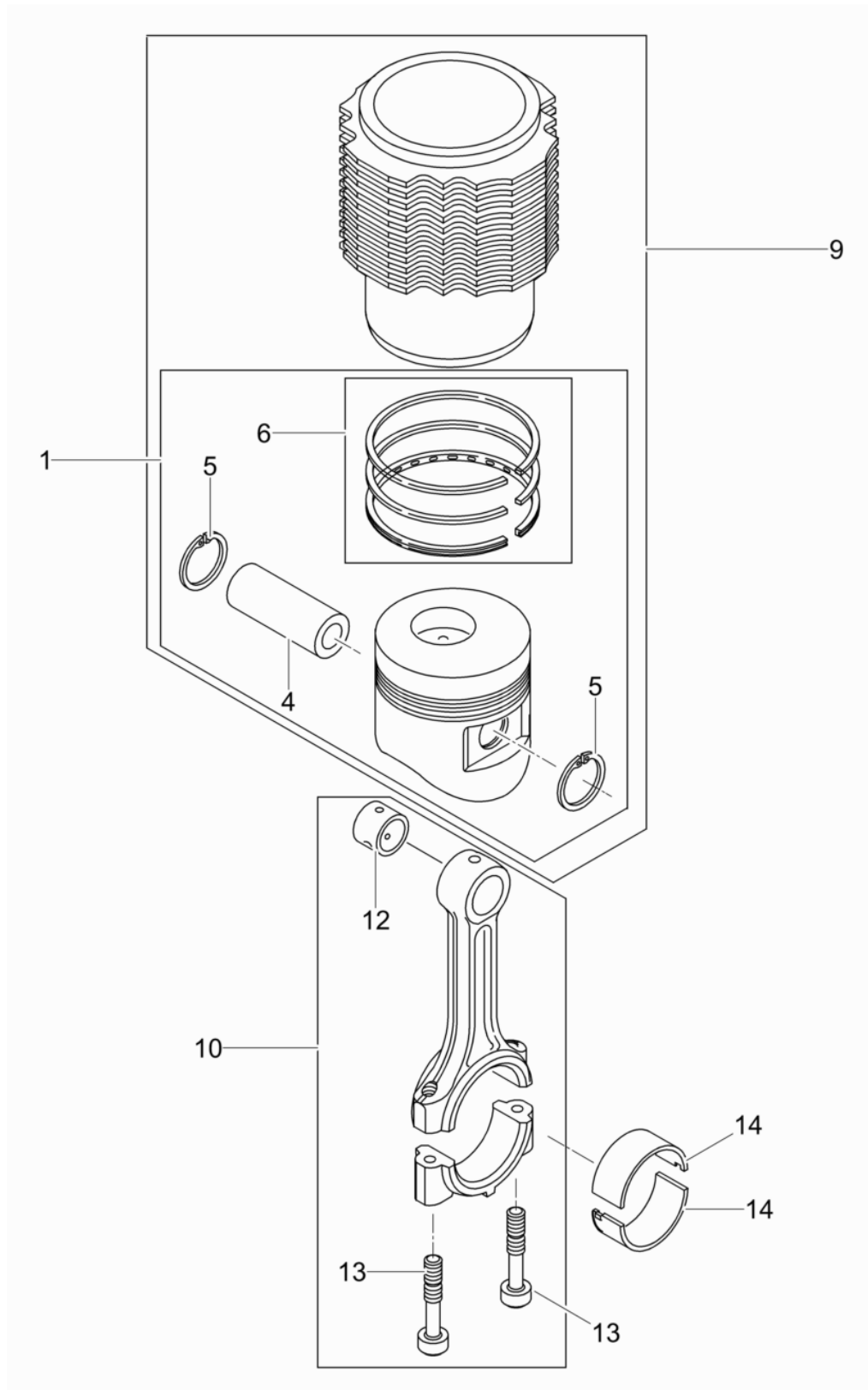

Ref. Pos.	Part No. Artikel Nr.	Qty. St.	Description Beschreibung	Descripción Description	Measurem./Abm.	Norm
					Torque/Drehm.	Sealant Schmierstoff
1	0226583	1	Piston Kolben	Pistón Piston		
1	0226584	1	Piston Kolben	Pistón Piston	+0,5	
1	0226585	1	Piston Kolben	Pistón Piston	+1	
4	0104347	1	Piston pin Kolbenbolzen	Perno de pistón Axe de piston		
5	0104348	2	Retaining ring Sicherungsring	Anillo de retención Bague d'arrêt		
6	0104346	1	Set of piston rings Kolbenringsatz	Juego de aros de pistón Jeu de segments de piston	90	
6	0106634	1	Set-piston rings Kolbenringsatz	Juego de anillos Jeu de segments	+1,0	
6	0207165	1	Set-piston rings Kolbenringsatz	Juego de anillos Jeu de segments	+0,5	
9	0226587	1	Cylinder with piston Zylinder mit Kolben	Cilindro con pistón Cylindre avec piston		
10	0104349	1	Connecting rod cpl. Pleuel kpl.	Biela cpl. Bielle cpl.		
12	0104350	1	Connecting rod bush Pleuelbuchse	Casquillo de biela Bôte de bielle		
13	0108022	2	Connecting rod screw Pleuelschraube	Tornillo de la biela Vis de bielle		
14	0104352	1	Connecting rod bearing Pleuellager	Cojinete de la biela Coussinet de bielle		
14	0106635	1	Connecting rod bearing Pleuellager	Cojinete de la biela Coussinet de bielle	-0,5	

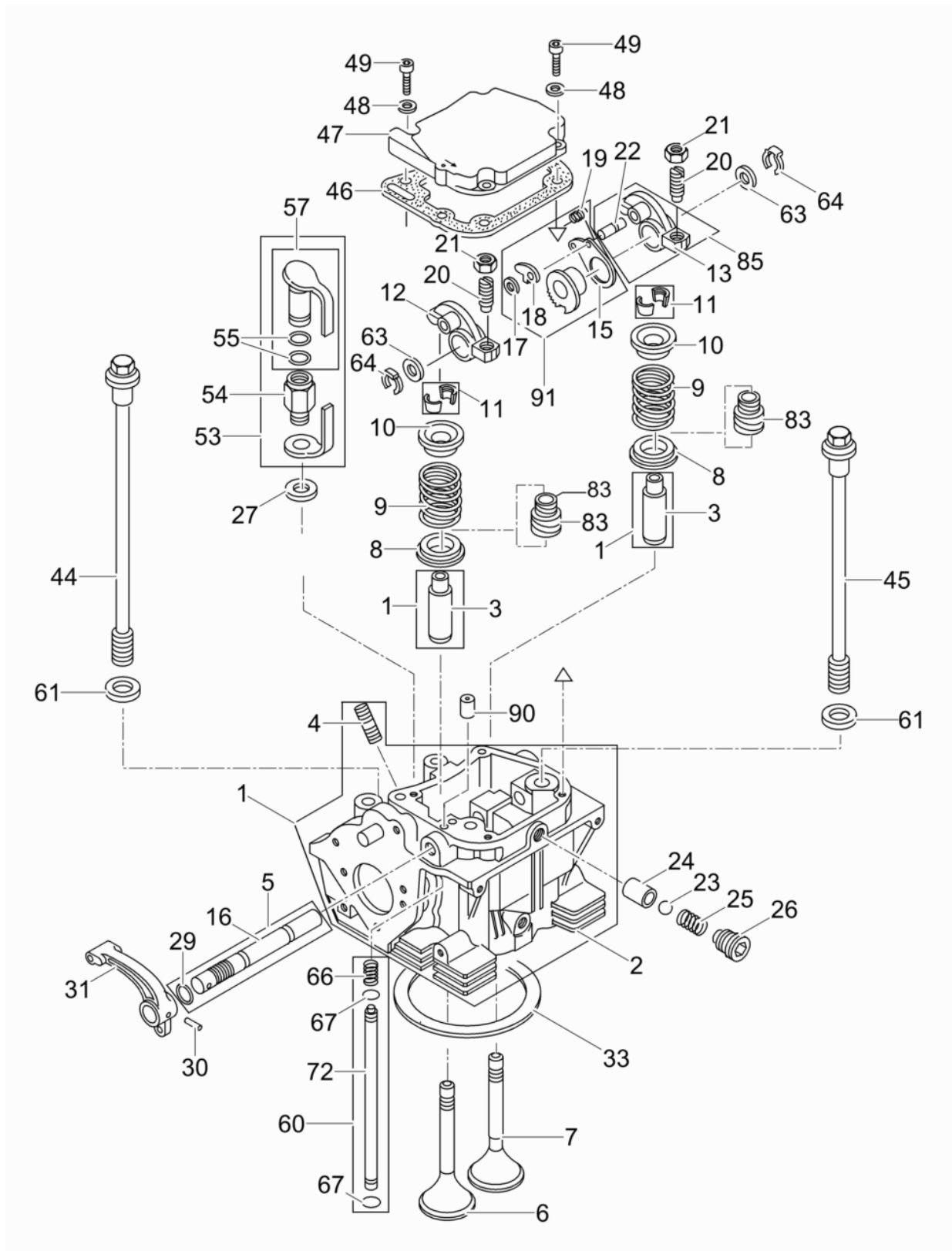

Ref. Pos.	Part No. Artikel Nr.	Qty. St.	Description Beschreibung	Descripción Description	Measurem./Abm.	Norm
					Torque/Drehm.	Sealant Schmierstoff
1	0226582	1	Cylinder head Zylinderkopf	Culata Culasse		
3	0126916	2	Valve guide Ventilführung	Guía de válvula Guide de soupape		
4	0201378	1	Threaded bolt Gewindebolzen	Perno roscado Boulon fileté	M8 x 40	
5	0106565	1	Rocker shaft Kipphebelachse	Eje de la balancín Axe de culbuteur		
6	0207806	1	Intake valve Einlassventil	Válvula de admisión Soupape d'admission		
7	0207807	1	Outlet valve Auslassventil	Válvula de escape Soupape d'échappement		
8	0094902	2	Washer Scheibe	Arandela Rondelle		
9	0104370	2	Valve spring Ventilfeder	Resorte de válvula Ressort de soupape		
10	0104369	2	Spring plate Federteller	Platillo de resorte Cuvette à ressort		
11	0047964	2	Set-valve cones Ventilkonussatz	Juego de conos de válvula Jeu de cônes de soupape		
12	0098449	1	Inlet rocker arm Einlaßkipphebel	Balancín de admisión Culbuteur		
15	0094895	1	Holder Halter	Soporte Attache		
17	0202427	1	Lock washer Sicherungscheibe	Arandela de seguridad Rondelle d'arrêt		
18	0094897	1	Ratchet (pawl) Mitnehmer	Trinquete Cliquet		
19	0094894	1	Spring Feder	Resorte Ressort		
20	0094891	2	Adjustment screw Einstellschraube	Tornillo de ajuste Vis d'ajustage		
21	4101500	2	Locknut Sechskantmutter	Contratuercas Contre-écrou	5/16 x 24in	
23	0066801	1	Ball Kugel	Bola Bille		
24	0094886	1	Bushing Buchse	Buje Douille		
25	0094887	1	Spring Feder	Resorte Ressort		
26	0094888	1	Screw Schraube	Tornillo Vis		
27	0013186	1	Gasket Dichtring	Anillo de junta Bague d'étanchéité	A12 x 15,5	DIN7603
29	0108801	1	O-ring O-Ring	Anillo-O Bague-O	8 x 2	
30	0020183	1	Spring pin Spannstift	Pasador de sujeción Goupille élastique	4 x 22	DIN1481
31	0094909	1	Decompression lever Hebel	Palanca de descompresión Manette de descompression		

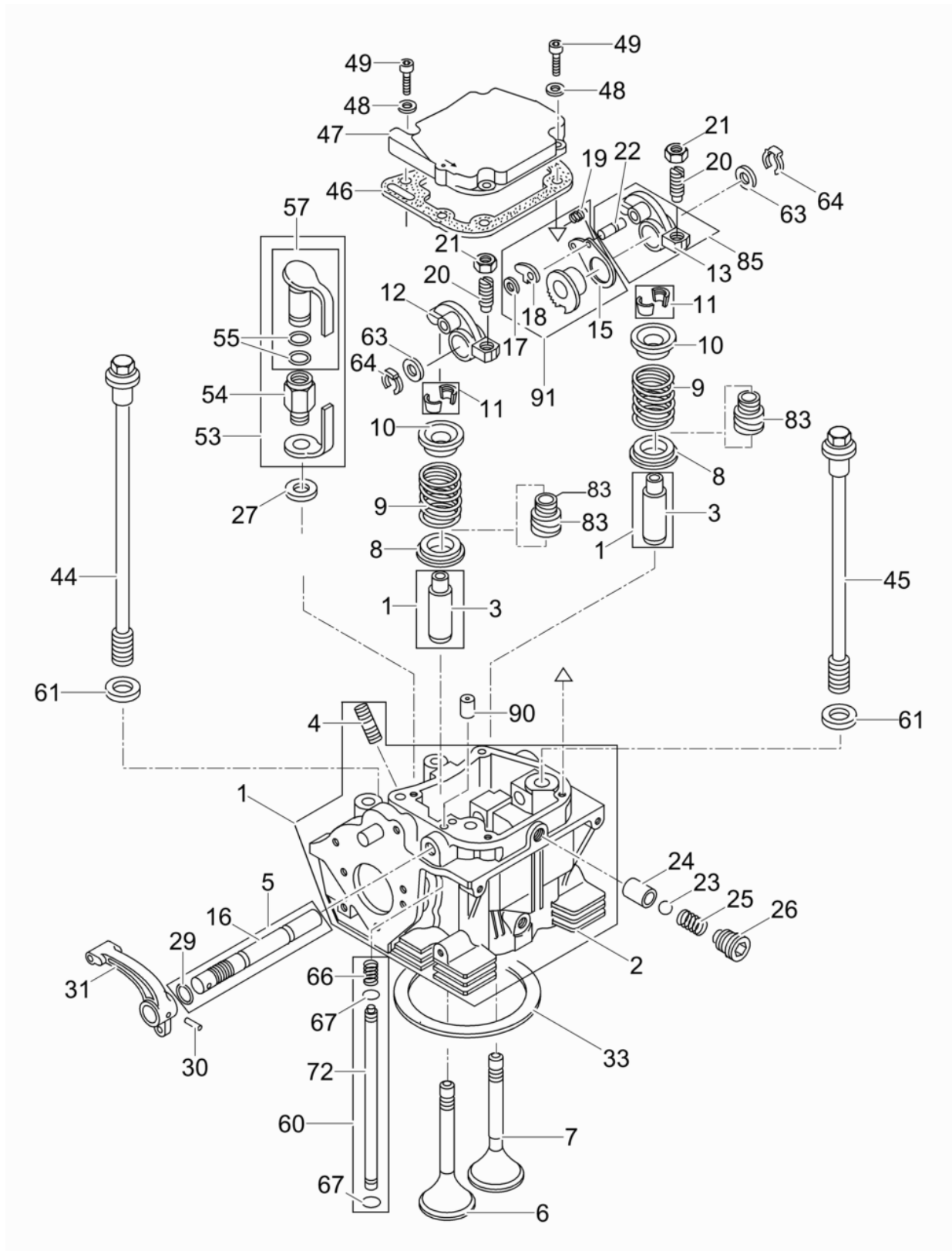

Ref. Pos.	Part No. Artikel Nr.	Qty. St.	Description Beschreibung	Descripción Description	Measurem./Abm.	Norm
					Torque/Drehm.	Sealant Schmierstoff
33	0104377	1	Gasket Dichtung	Junta Joint	0,30	
33	0207803	1	Gasket Dichtung	Junta Joint	1,25	
33	0207802	1	Gasket Dichtung	Junta Joint	1,15	
33	0207801	1	Gasket Dichtung	Junta Joint	1,05	
33	0207800	1	Gasket Dichtung	Junta Joint	0,95	
33	0207799	1	Gasket Dichtung	Junta Joint	0,85	
33	0207798	1	Gasket Dichtung	Junta Joint	0,75	
33	0207797	1	Gasket Dichtung	Junta Joint	0,65	
33	0207796	1	Gasket Dichtung	Junta Joint	0,55	
33	0207795	1	Gasket Dichtung	Junta Joint	0,45	
33	0207794	1	Gasket Dichtung	Junta Joint	0,35	
33	0104387	1	Gasket Dichtung	Junta Joint	1,30	
33	0104386	1	Gasket Dichtung	Junta Joint	1,20	
33	0104385	1	Gasket Dichtung	Junta Joint	1,10	
33	0104384	1	Gasket Dichtung	Junta Joint	1,00	
33	0104383	1	Gasket Dichtung	Junta Joint	0,90	
33	0104382	1	Gasket Dichtung	Junta Joint	0,80	
33	0104381	1	Gasket Dichtung	Junta Joint	0,70	
33	0104380	1	Gasket Dichtung	Junta Joint	0,60	
33	0104379	1	Gasket Dichtung	Junta Joint	0,50	
33	0104378	1	Gasket Dichtung	Junta Joint	0,40	
44	0104363	2	Cylinder head bolt Zylinderkopfschraube	Tornillo de cabeza cilíndrica Vis de culasse		
45	0104364	2	Cylinder head bolt Zylinderkopfschraube	Tornillo de cabeza cilíndrica Vis de culasse		
46	0098445	1	Gasket Dichtung	Junta Joint		
47	0098444	1	Cover Deckel	Tapa Couvercle		

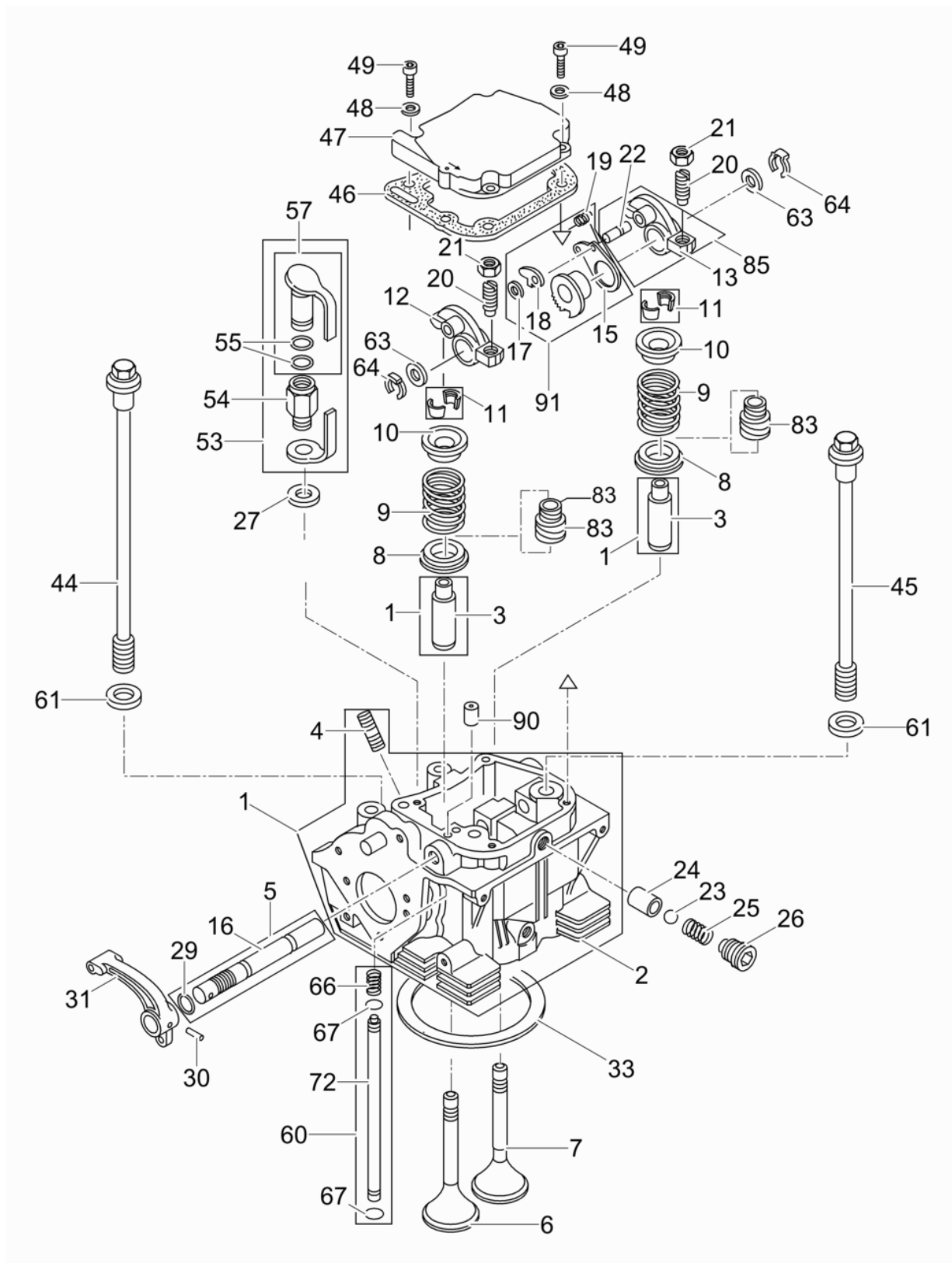

Ref. Pos.	Part No. Artikel Nr.	Qty. St.	Description Beschreibung	Descripción Description	Measurem./Abm.	Norm
					Torque/Drehm.	Sealant Schmierstoff
48	0151290	4	Spring washer Federscheibe	Arandela elástica Rondelle à ressort	A6	DIN137
49	0129010	4	Cheese head screw Zylinderschraube	Tornillo cilíndrico Vis à tête cylindrique	M6 x 25	DIN912
53	0102468	1	Fuel primer Dosiereinrichtung	Imprimador Dispositif d'injection au		
55	0107390	2	O-Ring O-Ring	Anillo-O Joint torique	11,3 x 2,4	
57	0102469	1	Plug (threaded) Verschlußstopfen	Tapón roscado Bouchon		
60	0104373	1	Grease pipe Schmierrohr	Tubo de lubricación Tube graisseur		
61	0104365	4	Washer Scheibe	Arandela Rondelle	10.1 x 22 x 3	
63	0104388	2	Washer Scheibe	Arandela Rondelle	2,5	
64	0104389	2	Retaining ring Sicherungsring	Anillo de retención Bague d'arrêt		
66	0094903	1	Spring Feder	Resorte Ressort		
67	0094905	2	O-Ring O-Ring	Anillo-O Joint torique		
83	0104371	2	Seal Abdichtung	Junta Joint		
85	0098448	1	Exhaust rocker arm Auslaßkipphebel	Balancín de escape Culbuteur		
90	0202405	1	Pin Stift	Espiga Goupille		
91	0126917	1	Toothed segment cpl. Zahnsegment kpl.	Segmento dentado cpl. Secteur dentée cpl.		
93	0128851	1	Nose cap cpl. Verschlußkappe kpl.	Caperuza de cierre cpl. Chape de fermeture cpl.		
95	0151217	2	Gasket Wellendichtring	Anillo de sellado Anneau d'étanchéité	26x35x3	
96	0047969	1	Oil fill tube Unterteil	Tubo llenador de aceite Tube-remplisseur d'huile		
97	0204567	1	Cover Zylinderkopfdeckel	Tapa Couvercle		

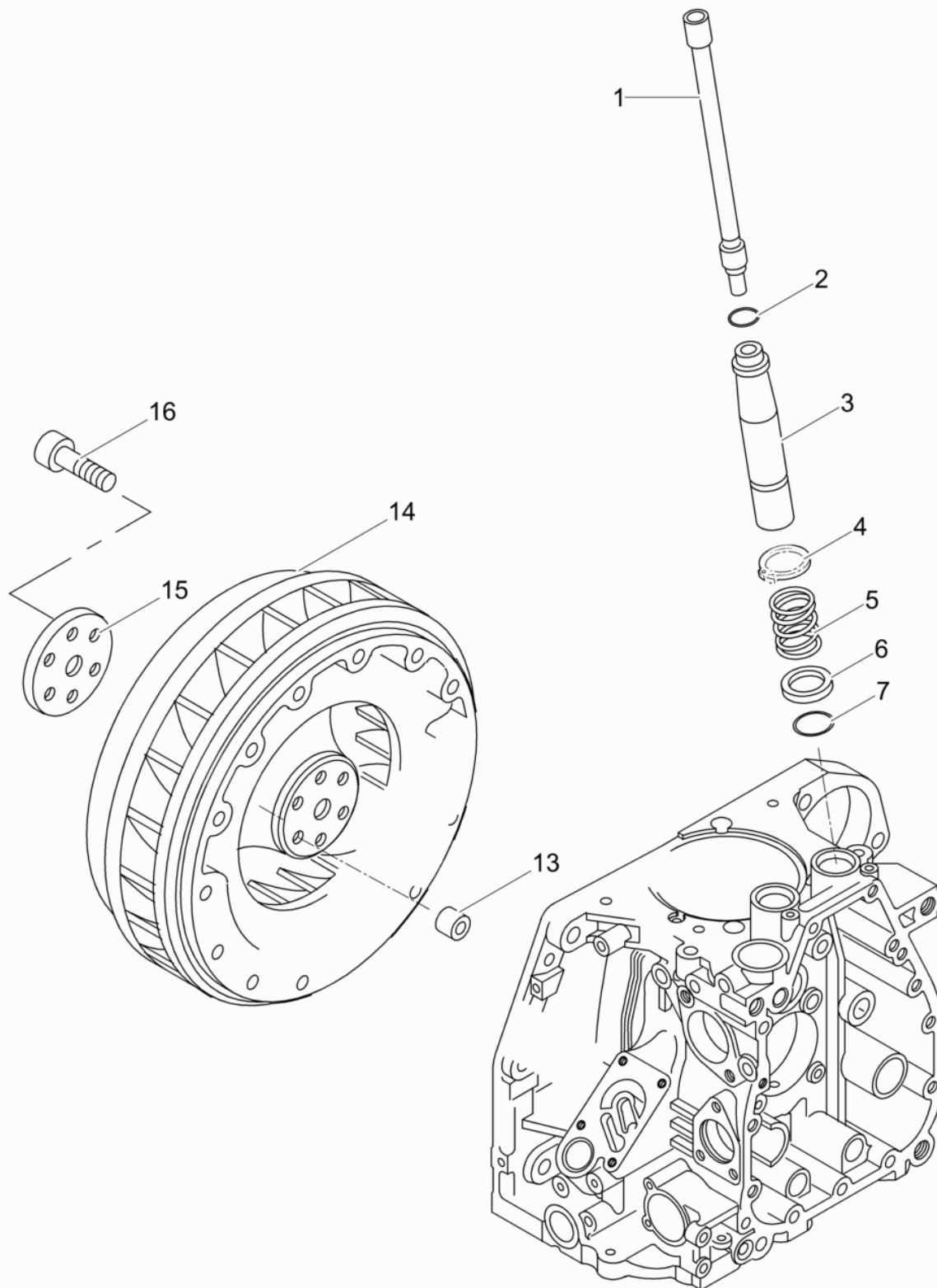

Ref. Pos.	Part No. Artikel Nr.	Qty. St.	Description Beschreibung	Descripción Description	Measurement./Abm.	Norm
					Torque/Drehm.	Sealant Schmierstoff
1	0104401	2	Push rod Stoßstange	Varilla de empuje Poussoir		
2	0094944	2	O-Ring O-Ring	Anillo-O Joint torique		
3	0104400	2	Pipe Rohr	Tubo Tube		
4	0094942	2	Retaining ring Sicherungsring	Anillo de retención Bague d'arrêt	24 x 1,75	DIN471
5	0094941	2	Spring Feder	Resorte Ressort		
6	0094940	2	Washer Scheibe	Arandela Rondelle		
7	0104399	2	O-ring O-Ring	Anillo-O Bague-O		
13	0104427	1	Fixing sleeve Fixierhülse	Casquillo de fijación Douille de fixation		
14	0226590	1	Fly wheel Schwungrad	Volante Volant		
15	0104429	1	Fixing disc Fixierscheibe	Arandela de retención Rondelle de fixation		
16	0202429	6	Hexagon socket head screw Innensechskantschraube	Tornillo a seis lados huecos Vis à six pans creux	M10 x 40	

Oil Pump-Governor
Ölpumpe-Regler
Bomba de Aceite-Regulador
Pompe à Huile-Régulateur

DPU5545Heh

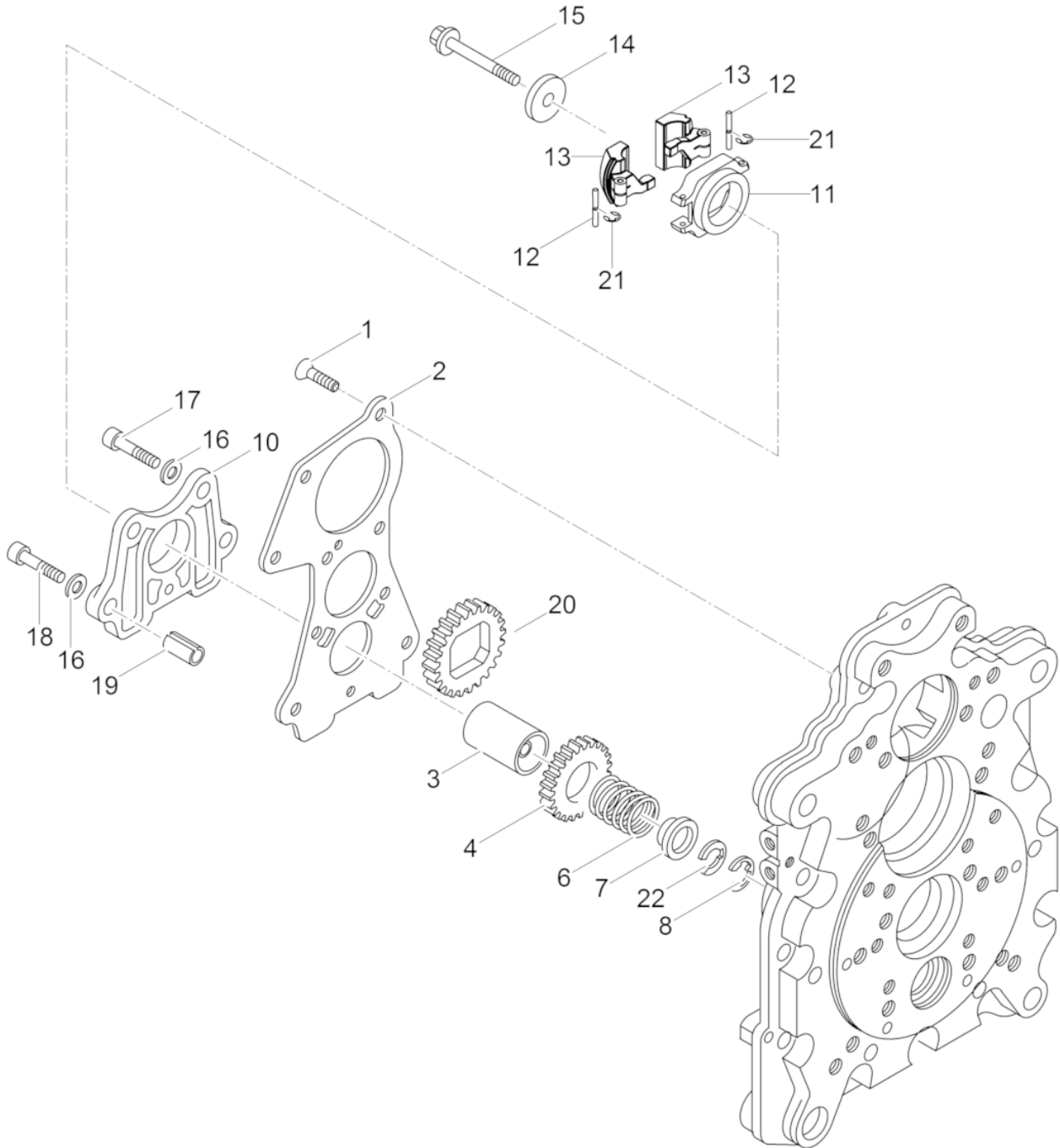

Ref. Pos.	Part No. Artikel Nr.	Qty. St.	Description Beschreibung	Descripción Description	Measurem./Abm.	Norm
					Torque/Drehm.	Sealant Schmierstoff
1	0095000	5	Screw Senkschraube	Tornillo Vis		
2	0094999	1	Cover Flanschdeckel	Tapa Couvercle		
3	0095002	1	Bushing Lagerbuchse	Buje Douille		
4	0106532	1	Gear wheel Zahnrad	Engranaje Roue dentée		
6	0095004	1	Spring Feder	Resorte Ressort		
7	0095005	1	Spring holder Federteller	Soporte Support		
8	2004956	1	Lock washer Sicherungsscheibe	Arandela de seguridad Rondelle d'arrêt	5	DIN6799
10	0217097	1	Housing Gehäuse	Carcasa Enveloppe		
11	5100002769	1	Bracket Träger	Soporte Support		
12	5100002771	2	Bolt Bolzen	Perno Boulon		
13	5100002770	2	Eccentric weight Fliehgewicht	Peso centrífugo Poids centrifuge		
14	0094991	1	Washer Scheibe	Arandela Rondelle		
15	0094990	1	Bolt Bolzen	Perno Boulon		
16	0151290	5	Spring washer Federscheibe	Arandela elástica Rondelle à ressort	A6	DIN137
17	0129010	3	Cheese head screw Zylinderschraube	Tornillo cilíndrico Vis à tête cylindrique	M6 x 25	DIN912
18	0202422	2	Hexagon socket head screw Innensechskantschraube	Tornillo a seis lados huecos Vis à six pans creux	M6 x 30	
19	0107546	2	Roll pin Spannstift	Pasador Goupille de tension	8 x 12	
20	0106531	1	Gear wheel Zahnrad	Engranaje Roue dentée		
21	5100002772	2	Lock washer Sicherungsscheibe	Arandela de seguridad Rondelle d'arrêt		
22	0099416	3	Washer Scheibe	Arandela Rondelle	0,5	
22	0217100	1	Washer Scheibe	Disco Rondelle	0,3	

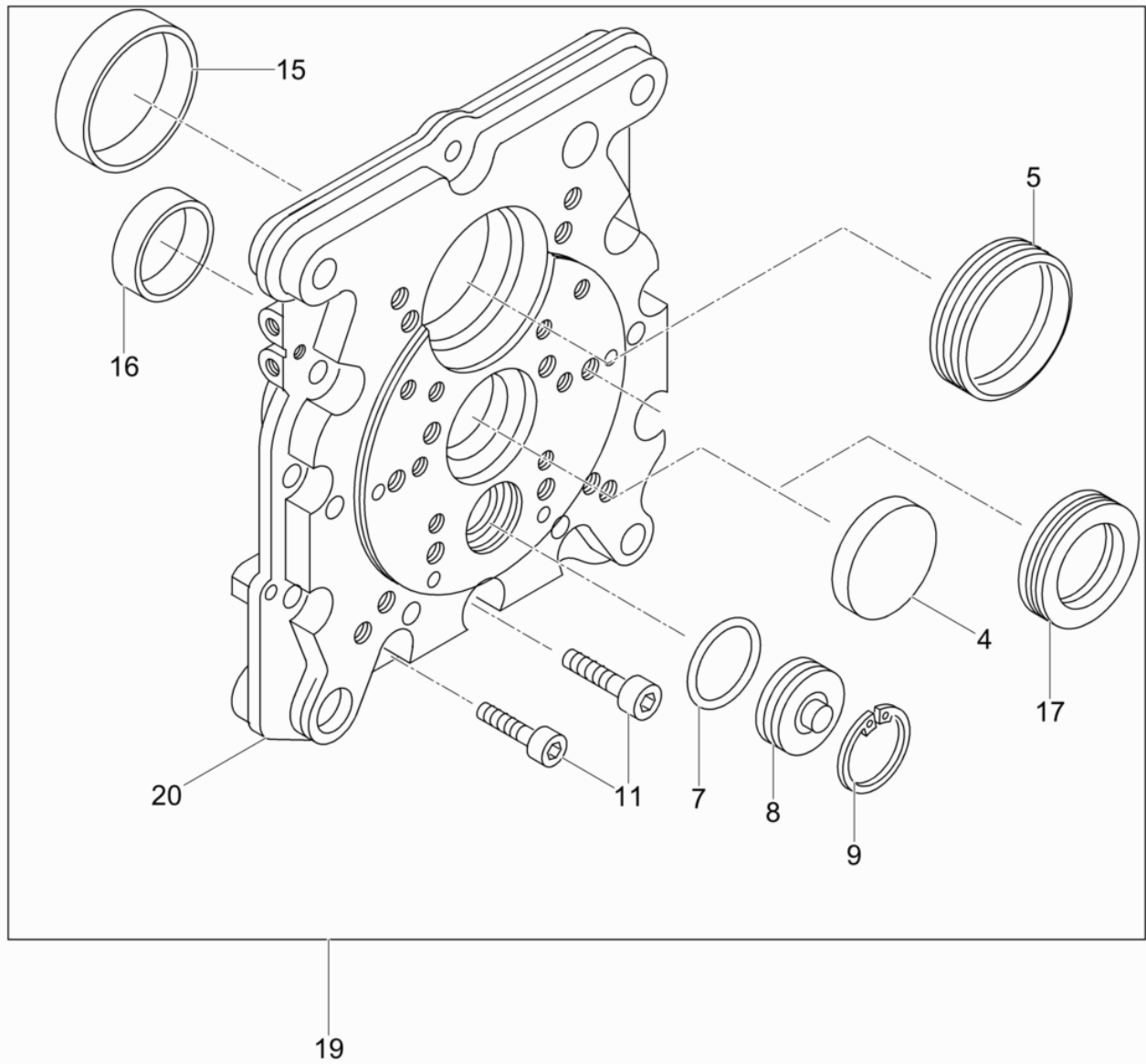

Ref. Pos.	Part No. Artikel Nr.	Qty. St.	Description Beschreibung	Descripción Description	Measurement./Abm.	Norm
					Torque/Drehm.	Sealant Schmierstoff
4	0095015	1	Cover Verschlußdeckel	Tapa Couvercle		
5	0095013	1	Shaft seal Wellendichtring	Sello del eje Bague d'étanchéité		
7	0095016	1	O-Ring O-Ring	Anillo-O Joint torique		
8	0095017	1	Cover Deckel	Tapa Couvercle		
9	0202455	1	Retaining ring Sicherungsring	Anillo de retención Bague d'arrêt	32 x 1,2	
11	0202462	12	Hexagon socket head screw Innensechskantschraube	Tornillo a seis lados huecos Vis à six pans creux	M8 x 30	
15	0095012	1	Bearing Gleitlager	Rodamiento Roulement		
16	0202385	1	Bearing bush Lagerbuchse	Casquillo del cojinete Bête de roulement		
17	0207607	1	Rotary shaft seal Wellendichtring	Anillo de retén radial Bague d'étanchéité		
19	0207776	1	Command Cover Steuerdeckel	Tapa del mando Couvercle de commande		

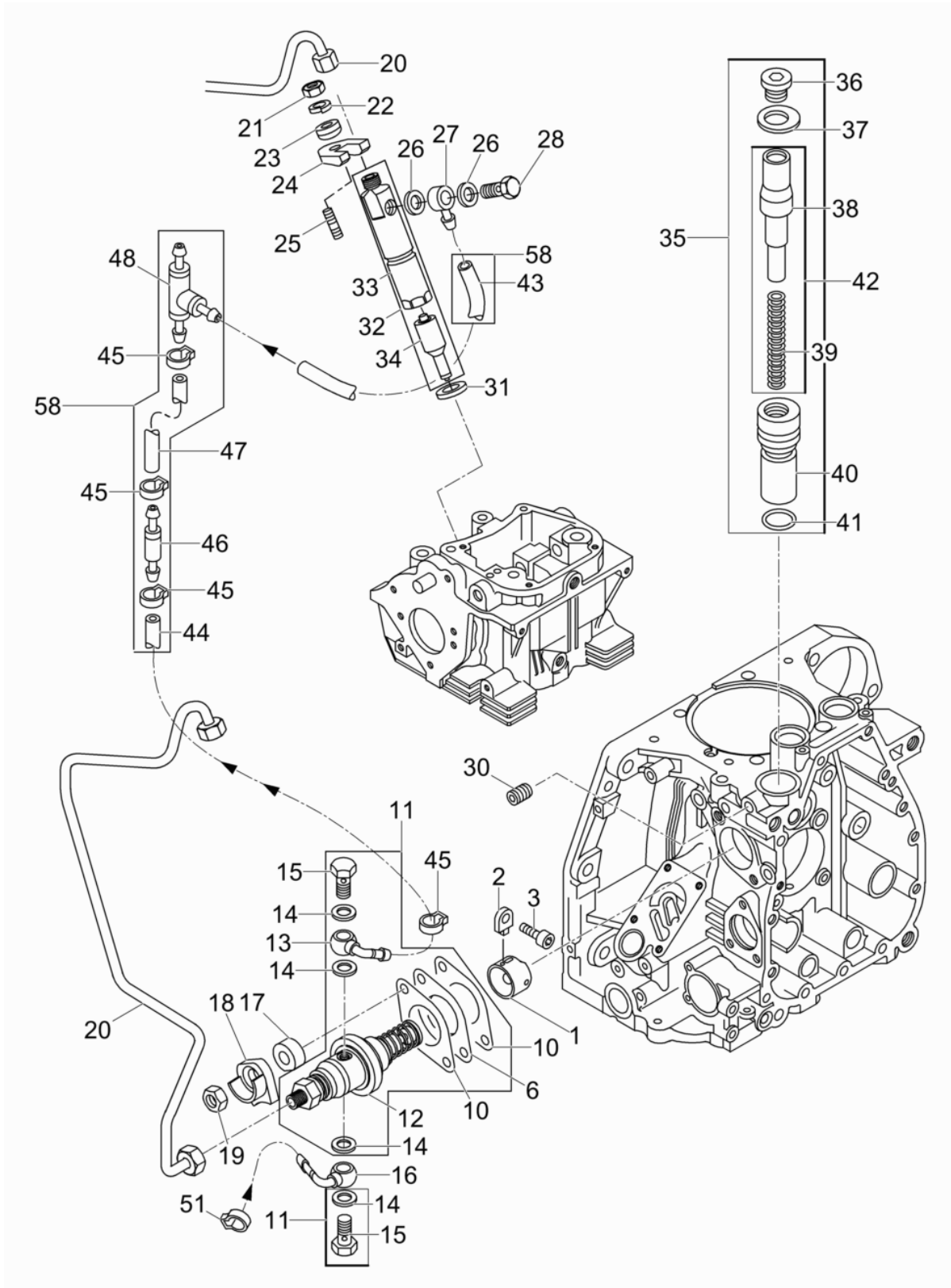

Ref. Pos.	Part No. Artikel Nr.	Qty. St.	Description Beschreibung	Descripción Description	Measurement/Abm.	Norm
					Torque/Drehm.	Sealant Schmierstoff
1	0126525	1	Tappet Stößel	Botador Pousoir		
2	0126526	1	Guide Führung	Guía Guide		
3	0202421	1	Hexagon socket head screw Innensechskantschraube	Tornillo a seis lados huecos Vis à six pans creux	M6 x 12	
6	0014482	1	Shim Ausgleichsscheibe	Laminilla Cale	0,3	
6	0207532	1	Shim Ausgleichsscheibe	Laminilla Cale	0,6	
6	0207533	1	Shim Ausgleichsscheibe	Laminilla Cale	0,9	
6	0207534	1	Shim Ausgleichsscheibe	Laminilla Cale	1,2	
10	0099419	2	Gasket Dichtung	Junta Joint	0.1	
10	0207543	2	Gasket Dichtung	Junta Joint	0.2	
10	0207544	2	Gasket Dichtung	Junta Joint	0.3	
11	0226588	1	Injection pump Einspritzpumpe	Bomba de inyección Pompe à injection		
13	0207809	1	Screw nipple Anschraubnippel	Boquilla roscada Raccord de vissage		
14	0215374	4	Seal ring Dichtring	Anillo sellante Bague d'étanchéité		
15	0210452	2	Hollow screw Hohlschraube	Tornillo hueco Boulon creux à filet femelle	M 8 x 1	
16	0207525	1	Screw nipple Anschraubnippel	Boquilla roscada Raccord de vissage		
17	0207555	2	Spacer Distanzstück	Pieza distanciadora Pièce d'écartement		
18	0207592	2	Clamping clamp Spannpratze	Abrazadera de Clamping Bride de Clamping		
19	0207805	2	Hexagon nut Sechskantmutter	Tuerca hexagonal Écrou hexagonal	M8	
20	0207777	1	Pipe Kraftstoffdruckrohr	Tubo Tube		
21	0151379	1	Locknut Sechskantmutter	Contratuerca Contre-écrou	M8	ISO4032
22	0151218	1	Lock washer Federring	Arandela elástica Rondelle de ressort	8	
23	0095021	1	Disc Kugelscheibe	Disco Disque		
24	0207564	1	Flange Flansch	Brida Bride		
25	0201378	1	Threaded bolt Gewindebolzen	Perno roscado Boulon fileté	M8 x 40	
26	0128957	2	Gasket Dichtring	Anillo de junta Bague d'étanchéité		

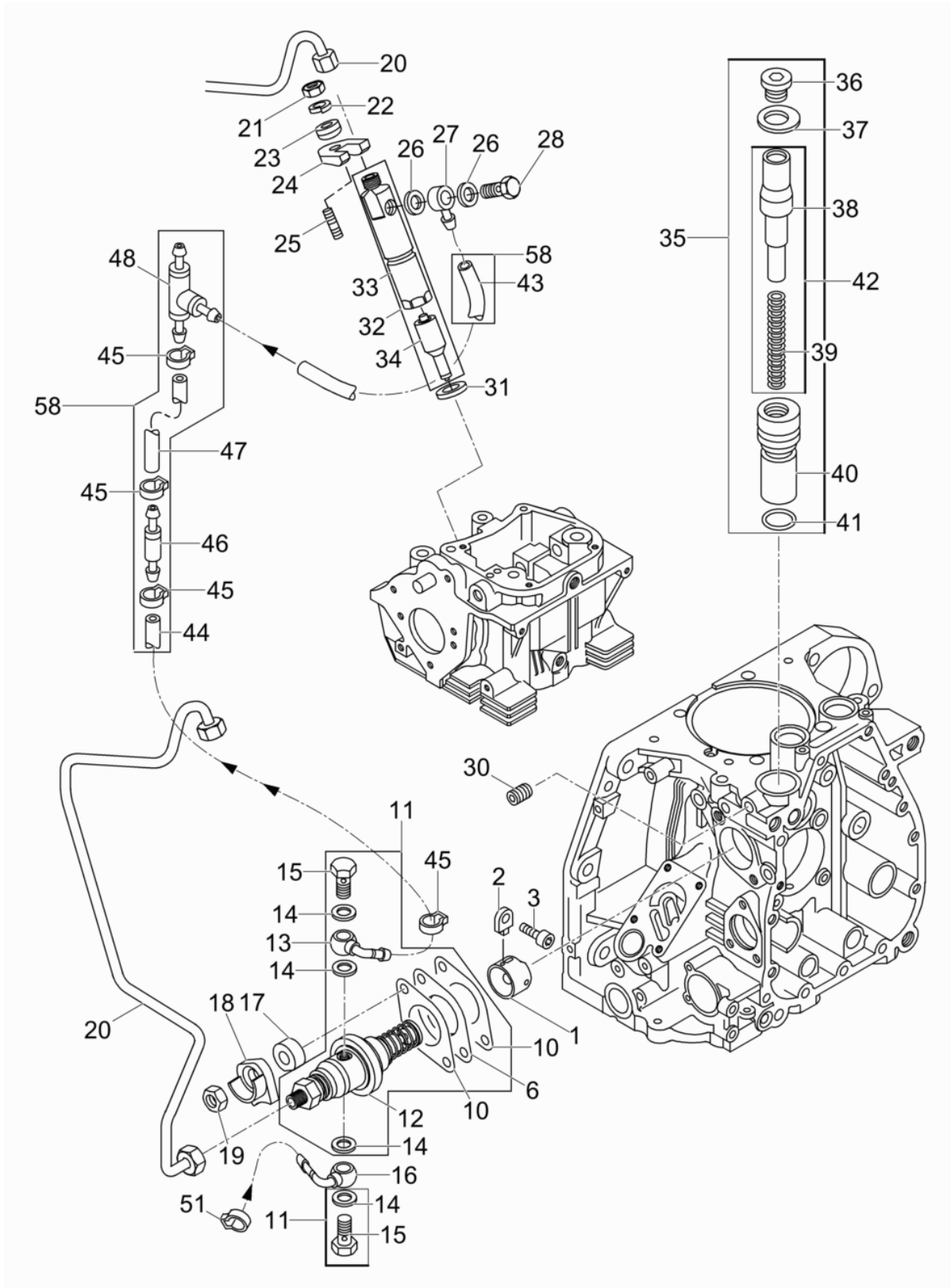

Ref. Pos.	Part No. Artikel Nr.	Qty. St.	Description Beschreibung	Descripción Description	Measurement/Abm.	Norm
					Torque/Drehm.	Sealant Schmierstoff
27	0095020	1	Fitting Nippel	Unión Raccord		
28	0095019	1	Banjo bolt Hohlschraube	Perno hueco Boulon creux à filet femelle		
30	0020348	1	Threaded pin Gewindestift	Varilla roscada Goupille fileté	M8 x 16	DIN916
31	0104411	1	Gasket Dichtring	Anillo de junta Bague d'étanchéité		
32	0226597	1	Injection Valve Einspritzventil	Válvula Inyectora Soupape d'Injection		
34	0226599	1	Jet Düse	Chicler Gicleur		
35	0095007	1	Housing Gehäuse	Carcasa Carter		
36	0207601	1	Screw Plug Verschlußschraube	Tapón Roscado Vis de Fermeture		
37	0095006	1	Washer Scheibe	Arandela Rondelle		
39	0207556	1	Spring Feder	Resorte Ressort		
40	0207609	1	Housing Gehäuse	Carcasa Carter		
41	0095008	1	O-Ring O-Ring	Anillo-O Joint torique	22,0 x 1,6	
42	0095009	1	Steering part Steuerteil	Elemento de mando Régulateur		
43	0095018	1	Hose Leitung	Manguera Tuyau	160	
44	0216517	1	Fuel hose Kraftstoffleitung	Manguera de combustible Tuyau à essence	4.5x135	
45	0207586	4	Clamp Schlauchklemme	Abrazadera Collier de serrage		
46	0047977	1	Hose fitting Ventil	Unión Raccord		
47	0216520	1	Fuel hose Kraftstoffleitung	Manguera de combustible Tuyau à essence	4.5x150	
48	0099417	1	Tee-fitting T-Stück	Unión forma T Raccord "T"		
51	0226598	1	Clamp Schlauchklemme	Abrazadera Collier de serrage	12	
58	0226603	1	Fuel hose Kraftstoffleitung	Manguera de combustible. Tuyau à essence		

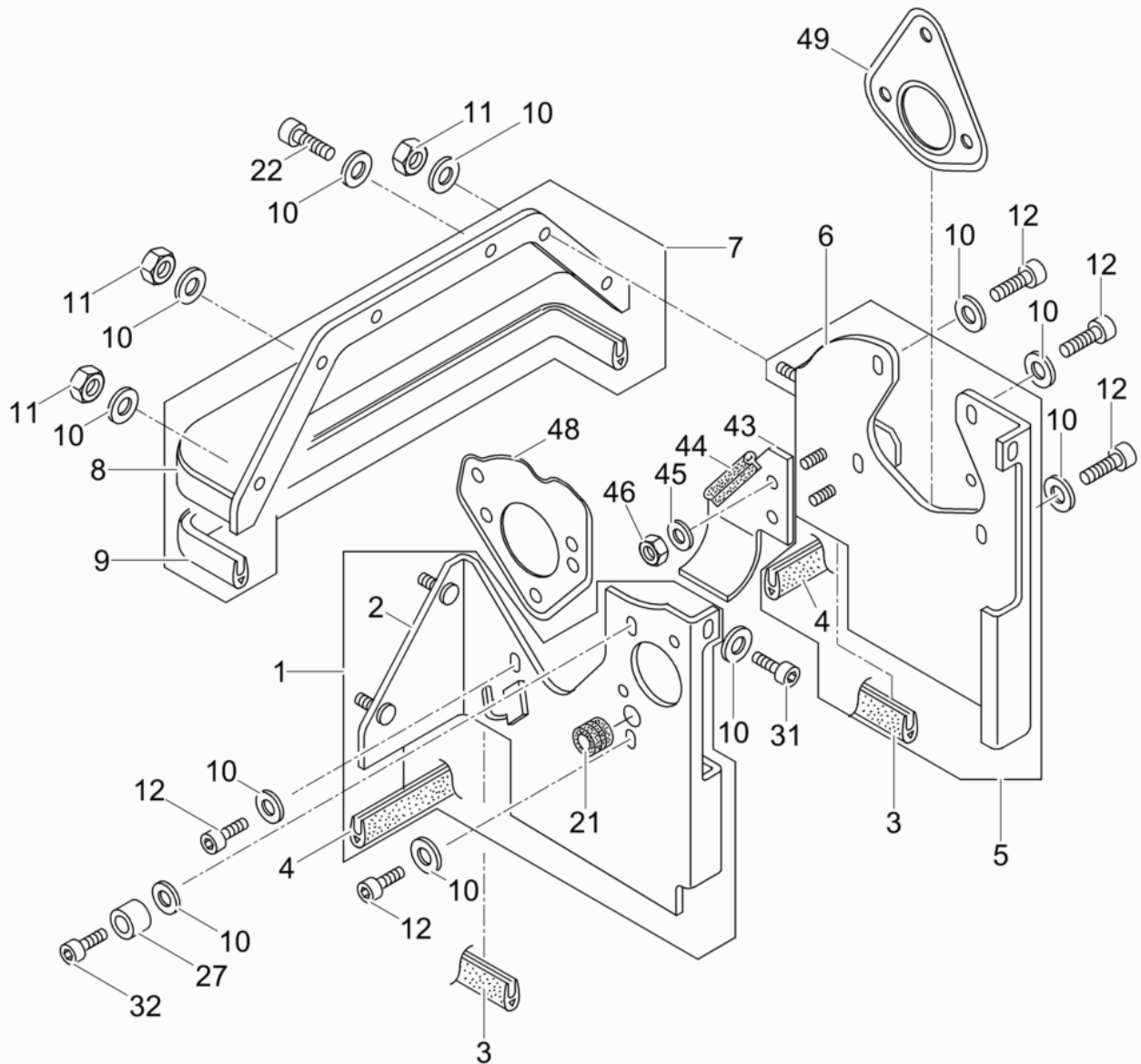

Ref. Pos.	Part No. Artikel Nr.	Qty. St.	Description Beschreibung	Descripción Description	Measurement./Abm.	Norm
					Torque/Drehm.	Sealant Schmierstoff
1	0207770	1	Baffle Luftleitblech	Deflector Déflecteur		
3	0207790	2	Seal Dichtungsprofil	Empaque Joint	29mm	
4	0207791	2	Seal Dichtungsprofil	Empaque Joint	41mm	
5	0207771	1	Baffle Luftleitblech	Deflector Déflecteur		
7	0104417	1	Hood cpl. Verkleidung kpl.	Revestimiento cpl. Revêtement cpl.		
9	0202408	1	Seal Wellendichtring	Anillo de sellado Anneau d'étanchéité	308	
10	0207593	15	Spring washer Spannscheibe	Arandela elástica Disque de serrage		
11	0151323	4	Locknut Sechskantmutter	Contratuerca Contre-écrou	M6	ISO4032
12	0151370	6	Cheese head screw Zylinderschraube	Tornillo cilíndrico Vis à tête cylindrique	M6 x 12	ISO4762
21	0107379	1	Grommet Gummitülle	Ojal Passe-fil		
22	0201380	2	Cheese head screw Zylinderschraube	Tornillo cilíndrico Vis à tête cylindrique	M6 x 16	
27	0104423	1	Bush Buchse	Buje Boîte		
31	0201380	2	Cheese head screw Zylinderschraube	Tornillo cilíndrico Vis à tête cylindrique	M6 x 16	
32	0129009	1	Cheese head screw Zylinderschraube	Tornillo cilíndrico Vis à tête cylindrique	M6 x 16	DIN912
43	0226602	1	Baffle Luftleitblech	Deflector Déflecteur		
44	0226592	1	Profiled joint Dichtungsprofil	Junta Joint d'étanchéité profilé	60mm	
45	0151540	2	Washer Scheibe	Arandela Rondelle	A6,4	DIN9021
46	0129021	2	Locknut Sechskantmutter	Contratuerca Contre-écrou	VM6	
48	0207792	1	Gasket Dichtung	Junta Joint		
49	0226593	1	Gasket Dichtung	Junta de estanqueidad Garniture		

Breather - Governor
Entlüftung-Drehzahlverstellung
Purgado - Regulador de Revoluciones
Raccord Fileté de Purgé -

DPU5545Heh

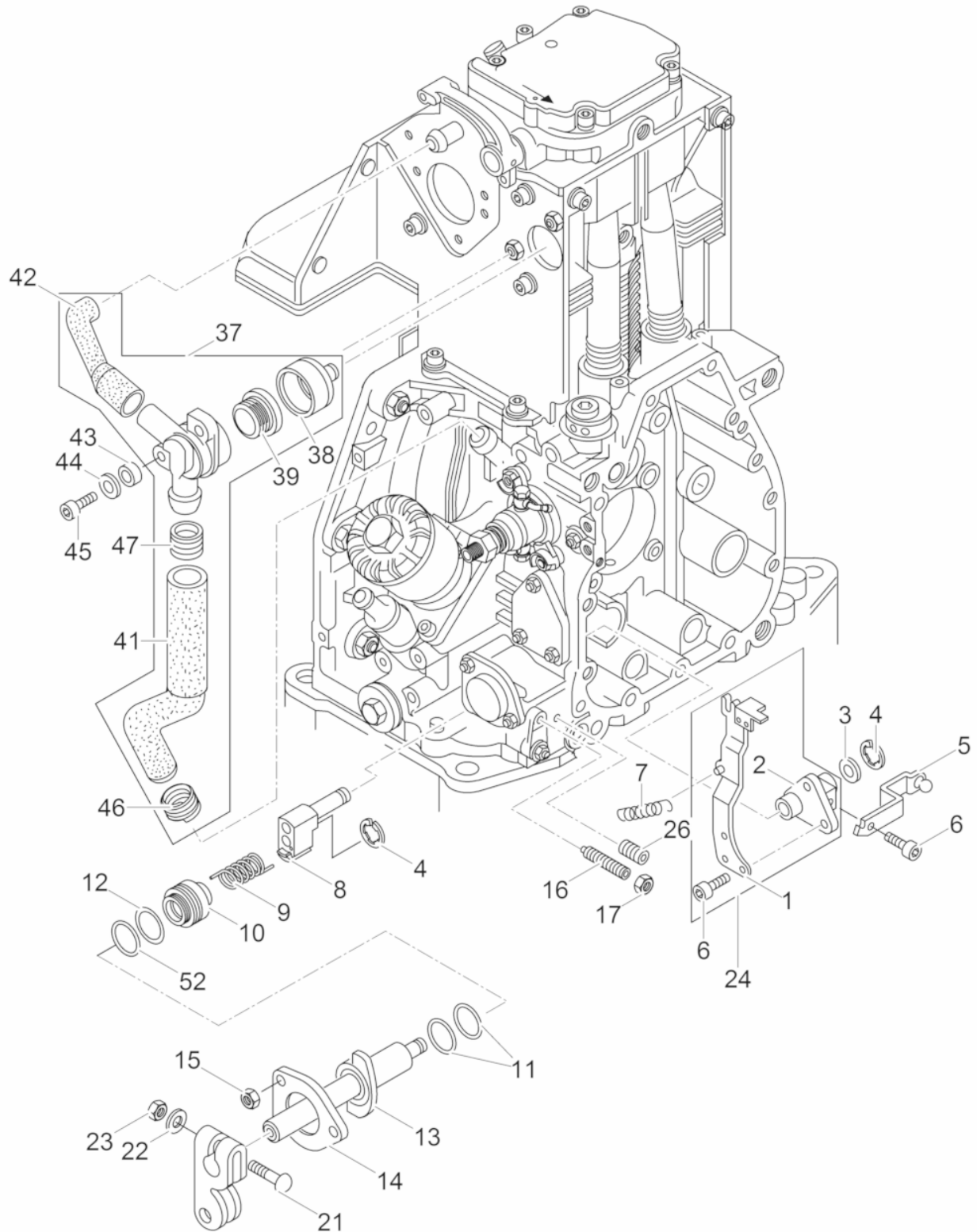

Ref. Pos.	Part No. Artikel Nr.	Qty. St.	Description Beschreibung	Descripción Description	Measurem./Abm.	Norm
					Torque/Drehm.	Sealant Schmierstoff
3	0094970	1	Washer Scheibe	Arandela Rondelle		
4	0202444	2	Lock washer Sicherungsscheibe	Arandela de Seguridad Rondelle d'arrêt	6,0	
5	0094969	1	Governor lever Reglerhebel	Palanca de regulador Levier régulateur		
6	0202449	4	Hexagon socket head screw Innensechskantschraube	Tornillo a seis lados huecos Vis à six pans creux	M5 x 8	
7	0094966	1	Spring Feder	Resorte Ressort		
8	0097417	1	Guide Führung	Guía Guide		
9	0097416	1	Torsion spring Torsionsfeder	Resorte Ressort		
10	0202395	1	Distance ring Abstandsring	Anillo distanciador Bague intermediaire		
11	0202459	2	O-Ring O-Ring	Anillo-O Joint torique	18 x 2	
12	0094963	1	O-Ring O-Ring	Anillo-O Joint torique		
13	0202371	1	Shaft Welle	Eje Arbre		
14	0103080	1	Flange Flansch	Brida Bride		
15	0129021	3	Locknut Sechskantmutter	Contratuerca Contre-écrou	VM6	
16	0126909	2	Threaded pin Gewindestift	Varilla roscada Goupille fileté		
17	0151323	2	Locknut Sechskantmutter	Contratuerca Contre-écrou	M6	ISO4032
20	0104407	1	Lever Hebel	Palanca Levier		
21	0094960	1	Screw Halbrundschrabe	Tornillo Vis		
22	0151324	1	Washer Scheibe	Arandela Rondelle	6.4	
23	0207588	1	Locknut Sechskantmutter	Contratuerca Contre-écrou	M6	
24	0126519	1	Governor lever cpl. Reglerhebel kpl.	Palanca de regulador cpl. Levier régulateur cpl.		
26	0202456	1	Threaded pin Gewindestift	Varilla roscada Goupille fileté	M8 x 20	
37	0098464	1	Bleeder valve Entlüftungsventil	Válvula purgadora Soupape de purge d'air		
38	0098461	1	Cap Kappe	Tapa Couvercle		
39	0094884	1	Diaphragm Membrane	Diafragma Diaphragme		
41	0104424	1	Breather tube Entlüftungsschlauch	Línea de purgado Tuyau d'évacuation purge		

Breather - Governor
Entlüftung-Drehzahlverstellung
Purgado - Regulador de Revoluciones
Raccord Fileté de Purge -

DPU5545Heh

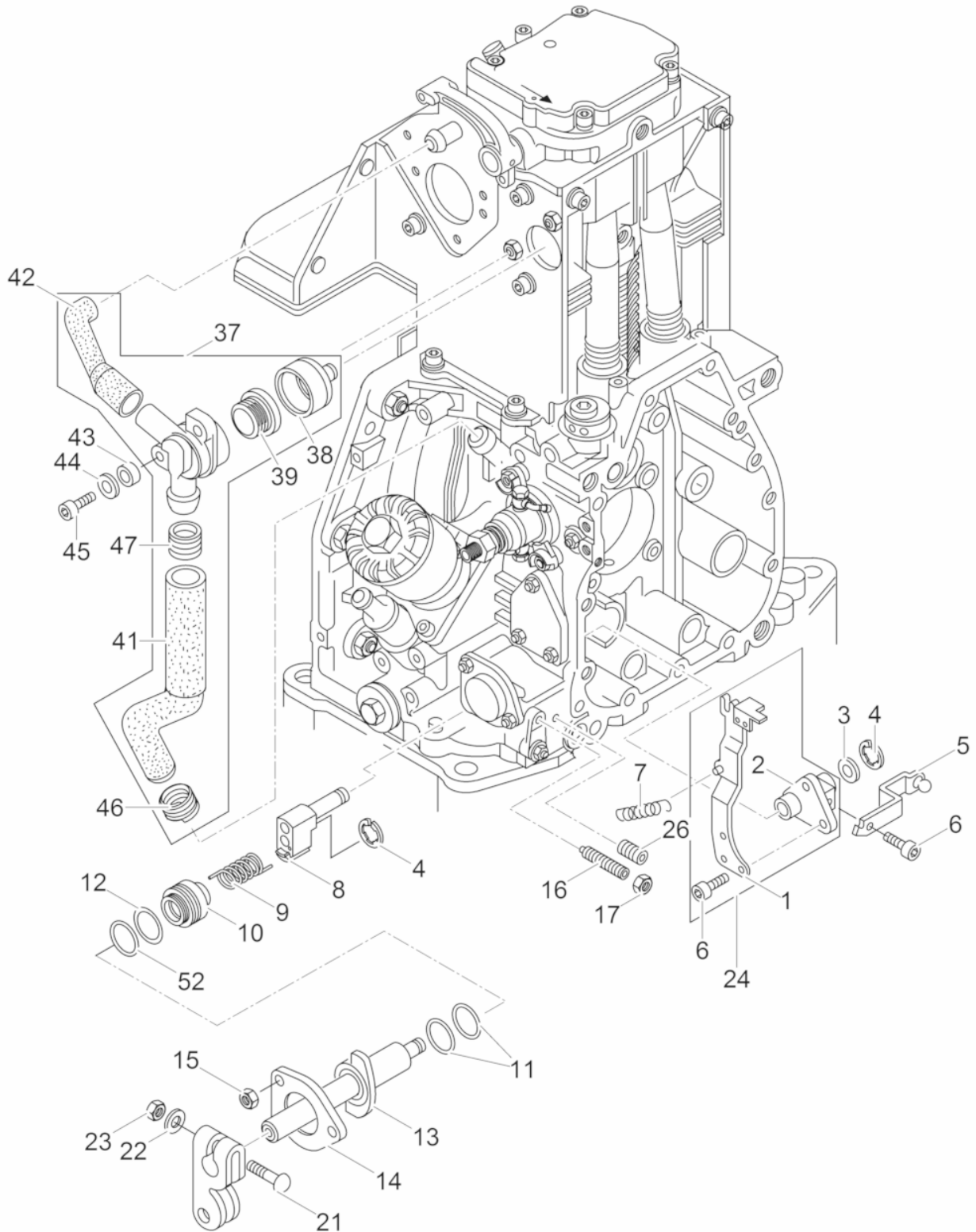

Ref. Pos.	Part No. Artikel Nr.	Qty. St.	Description Beschreibung	Descripción Description	Measurement./Abm.	Norm
					Torque/Drehm.	Sealant Schmierstoff
42	0098462	1	Breather tube Entlüftungsschlauch	Línea de purgado Tuyau d'évacuation purge		
43	0098465	2	Bushing Buchse	Buje Douille		
44	0151290	2	Spring washer Federscheibe	Arandela elástica Rondelle à ressort	A6	DIN137
45	0151231	2	Cheese head screw Zylinderschraube	Tornillo cilíndrico Vis à tête cylindrique	M6 x 16	ISO4762
46	0102470	1	Clip Federklemme	Borne de contacto elástico Pince de ressort		
47	0202407	1	Clamp Schelle	Abrazadera Collier		
52	0202466	1	Ring Ring	Anillo Bague	32 x 45 x 2.5	

Ref. Pos.	Part No. Artikel Nr.	Qty. St.	Description Beschreibung	Descripción Description	Measurement./Abm.	Norm
					Torque/Drehm.	Sealant Schmierstoff
1	0104440	1	Fuel tank Kraftstofftank	Tanque de combustible Réservoir de carburant		
3	0151344	8	Washer Scheibe	Arandela Rondelle		
4	0095355	8	Washer Gummischeibe	Arandela Rondelle		
5	0095356	4	Bushing Buchse	Buje Douille		
6	0095357	4	Sleeve Gummihülse	Manguito Douille		
8	0104441	2	Bush Buchse	Buje Boîte		
9	0031063	2	Stud bolt Stiftschraube	Tornillo espárrago Goupille fileté	M8 x 75	DIN835
10	0202438	2	Hexagonal head cap screw Sechskantschraube	Tornillo hexagonal Vis à tête hexagonale	M8 x 65	
11	0207814	1	Tank cap Tankverschluss	Tapa de tanque Couvercle du réservoir		
12	0217990	1	Fuel hose Kraftstoffleitung	Manguera de combustible Tuyau à essence		
13	0022832	1	Fuel filter Kraftstofffilter	Filtro de combustible Filtre à carburant		
14	0217991	1	Fuel hose Kraftstoffleitung	Manguera de combustible Tuyau à essence	7x180	
15	0203655	1	Clamp Schlauchklemme	Abrazadera Collier de serrage	16,00	
16	0207583	1	Nipple Nippel	Boquilla roscada Raccord fileté		
17	0207586	1	Clamp Schlauchklemme	Abrazadera Collier de serrage		
18	0207519	1	Fuel Pipe Kraftstoffleitung	Tubería de Combustible Tuyau à Combustible	5 x 75in	
19	0207780	1	Filter-fuel cpl. Kraftstofffilter kpl.	Filtro de combustible compl. Filtre à carburant compl.		
20	0104442	1	Strainer Sieb	Tamizador Tamis		
21	0104763	1	Washer Scheibe	Arandela Rondelle		
22	0202413	1	Screw Locking Schraubverschluß	Cierre Roscada Fermeture de Vissage		
23	0104443	2	Bush Buchse	Buje Boîte		
24	0207787	1	Fuel Pipe Kraftstoffleitung	Tubería de Combustible Tuyau à Combustible	5 x 40mm	
31	0151379	2	Locknut Sechskantmutter	Contratuerca Contre-écrou	M8	ISO4032
32	0151218	4	Lock washer Federring	Arandela elástica Rondelle de ressort	8	
41	0104446	1	Stone guard Steinschutz	Guardapiedras Grille de protection		

Ref. Pos.	Part No. Artikel Nr.	Qty. St.	Description Beschreibung	Descripción Description	Measurement/Abm.	Norm
					Torque/Drehm.	Sealant Schmierstoff
42	0104448	1	Stone guard Steinschutz	Guardapiedras Grille de protection		
43	0202432	1	Hexagon socket head screw Innensechskantschraube	Tornillo a seis lados huecos Vis à six pans creux	M6 x 10	
44	0151290	1	Spring washer Federscheibe	Arandela elástica Rondelle à ressort	A6	DIN137
46	0202338	1	Hexagonal head cap screw Sechskantschraube	Tornillo hexagonal Vis à tête hexagonale	M6 x 16	DIN933
47	0107451	1	Clamp Schelle	Abrazadera Agrafe		
48	0151324	1	Washer Scheibe	Arandela Rondelle	6.4	
49	0151323	1	Locknut Sechskantmutter	Contratuercas Contre-écrou	M6	ISO4032
51	0226598	1	Clamp Schlauchklemme	Abrazadera Collier de serrage	12	
52	0129791	1	Decal-Diesel Aufkleber-Diesel	Calcomanía-Diesel Autocollant-Diesel		
53	0151486	1	Sleeve Hülse	Collar Douille	7 x 12 x 16,3	
54	0107451	1	Clamp Schelle	Abrazadera Agrafe		
55	0151456	1	Lock washer Federring	Arandela elástica Rondelle de ressort	6	DIN128
56	0129007	1	Cheese head screw Zylinderschraube	Tornillo cilíndrico Vis à tête cylindrique	M6 x 30	ISO4762

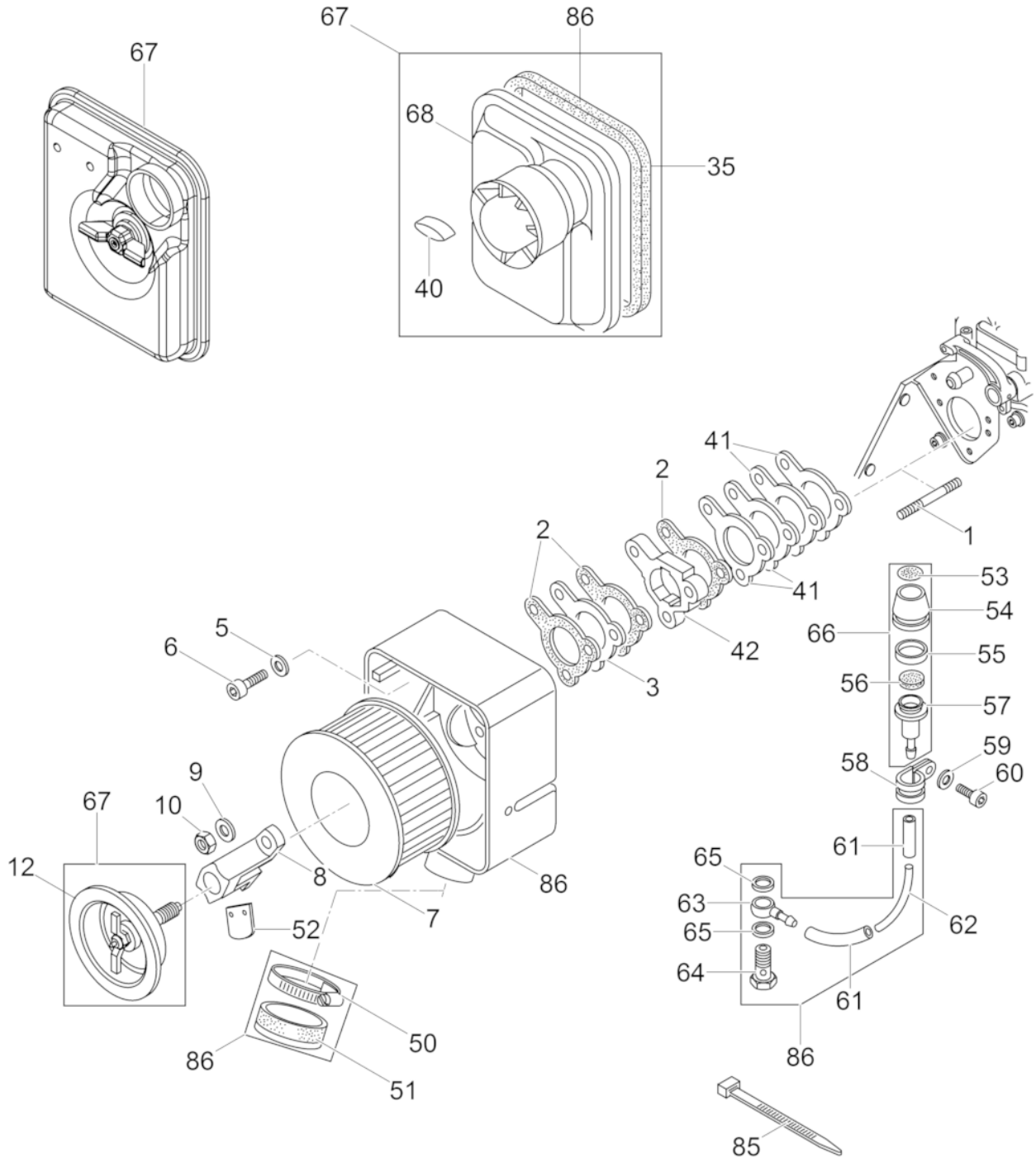

Ref. Pos.	Part No. Artikel Nr.	Qty. St.	Description Beschreibung	Descripción Description	Measurement/Abm.	Norm
					Torque/Drehm.	Sealant Schmierstoff
1	0207818	2	Screw Plug Verschlußschraube	Tapón Roscado Vis de Fermeture		
2	0104452	3	Seal Dichtung	Junta Joint		
3	0104453	1	Insulating flange Isolierflansch	Brida aislante Bride isolante		
5	0013601	1	Spring washer Federscheibe	Arandela elástica Rondelle à ressort	A8	DIN137
6	0202425	1	Hexagon socket head screw Innensechskantschraube	Tornillo a seis lados huecos Vis à six pans creux	M8 x 42	
7	0104455	1	Air filter Luftfilter	Filtro del aire Filtre à air		
8	0104456	1	Retainer Halter	Soporte Logement		
9	0151553	2	Washer Scheibe	Arandela Rondelle	B8,4	ISO7089
10	0129516	2	Nut Mutter	Tuerca Ecrou	M8	
12	510002773	1	Filter Cover cpl. Filterdeckel kpl.	tapa de filtro cpl. Couvercle de Filtre cpl.		
35	0104458	1	Seal Dichtung	Empaque Joint		
40	0108907	1	Wing nut Flügelmutter	Tuerca mariposa Ecrou papillon	M6	
41	0104450	1	Gasket set Dichtungssatz	Juego de juntas Jeu de joints		
42	0104451	1	Intermediate flange Zwischenflansch	Brida intermedia Bride intermediaire		
50	0099804	1	Clamp Schelle	Abrazadera Collier		
51	0104460	1	Manifold Krümmer	Multiple Raccord courbe		
52	0099792	1	Valve plate Ventilplatte	Placa de válvula Plaque de soupape		
53	0104462	1	Rubber ring Gummiring	Anillo de goma Bague en caoutchouc		
54	0099808	1	Rubber cap Gummikappe	Capuchón de goma Chape de caoutchouc		
55	0104462	1	Rubber ring Gummiring	Anillo de goma Bague en caoutchouc		
56	0109714	1	Filter disk Filterscheibe	Disco filtrante Rondelle de filtre		
57	0099949	1	Adaptor Adapter	Adaptador Adaptateur		
58	0095050	1	Pipe clamp Rohrschelle	Abrazadera Collier pour tuyau		
59	0151456	1	Lock washer Federring	Arandela elástica Rondelle de ressort	6	DIN128
60	0202437	1	Cheese head screw Zylinderschraube	Tornillo cilíndrico Vis à tête cylindrique	M6 x 20	

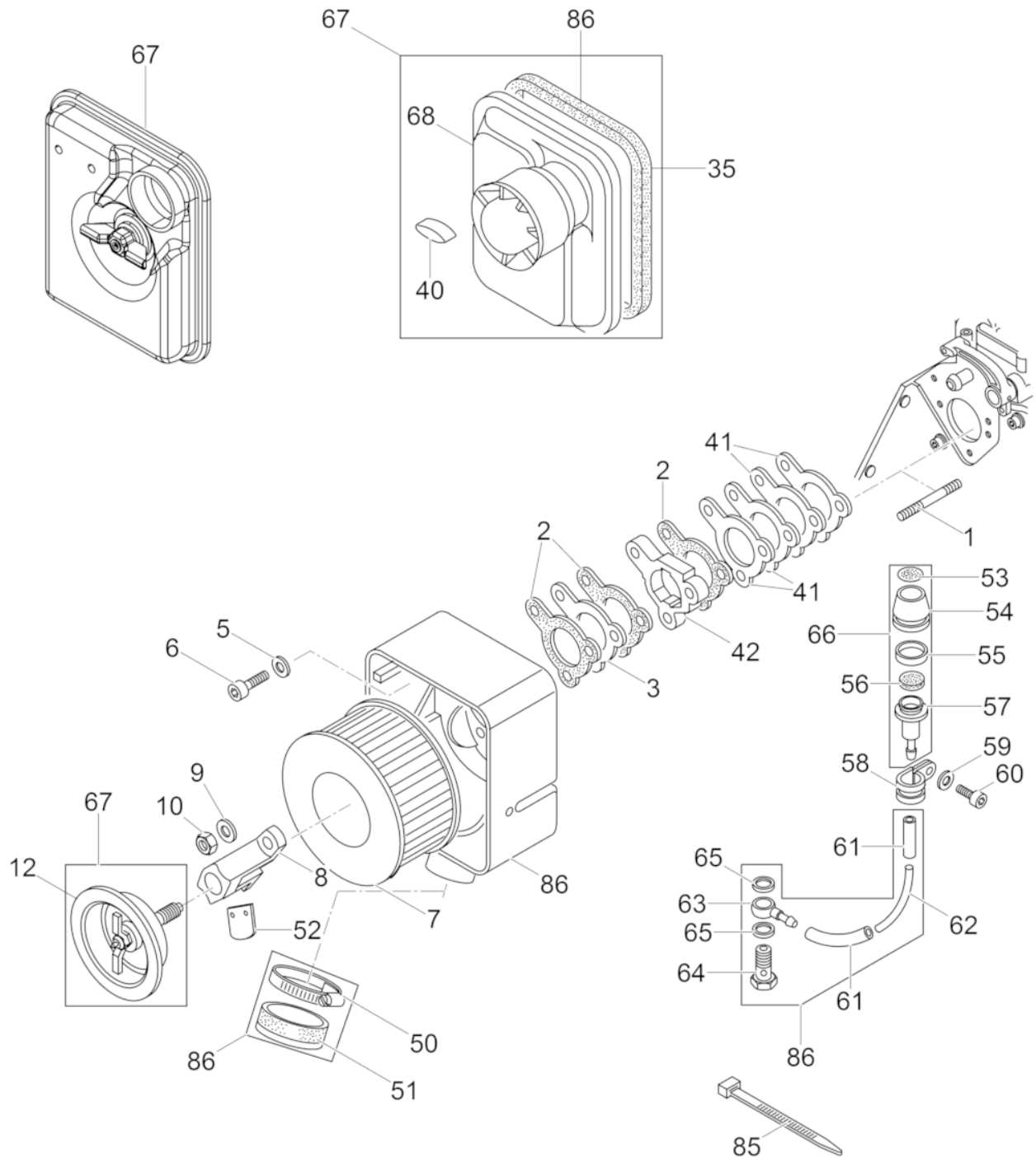

Ref. Pos.	Part No. Artikel Nr.	Qty. St.	Description Beschreibung	Descripción Description	Measurem./Abm.	Norm
					Torque/Drehm.	Sealant Schmierstoff
61	0217108	2	Fuel hose Kraftstoffleitung	Manguera de combustible Tuyau à essence	3,5 x 50	
62	0151536	1	Hose Schlauch	Manguera Tuyau	2 x 4 x 135	
63	0047981	1	Hose fitting Nippel	Unión Raccord		
64	0202417	1	Banjo bolt Hohlschraube	Perno hueco Boulon creux à filet femelle	A2-3	
65	0107342	2	Sealing ring Dichtungsring	Anillo sellante Bague d'étanchéité		
66	0109711	1	Maintenance indicator cpl. Wartungsanzeige kpl.	Indicador de mantenimiento Indicateur dentretien		
67	5100022093	1	Air cleaner cover Australia Luftfilterdeckel Austalien	Tapa-filtro del aire Australia Couvercle-filtre à air		
67	5100002776	1	Cover with cyclone Deckel mit Zyklon	Tapa con ciclón Couvercle avec cyclone		
85	0109710	1	Tie cable Kabelbinder	Fijación Attache		
86	0207783	1	Air filter housing cpl. Luftfiltergehäuse kpl.	Carcasa filtro de aire cpl. Carter de filtre cpl.		

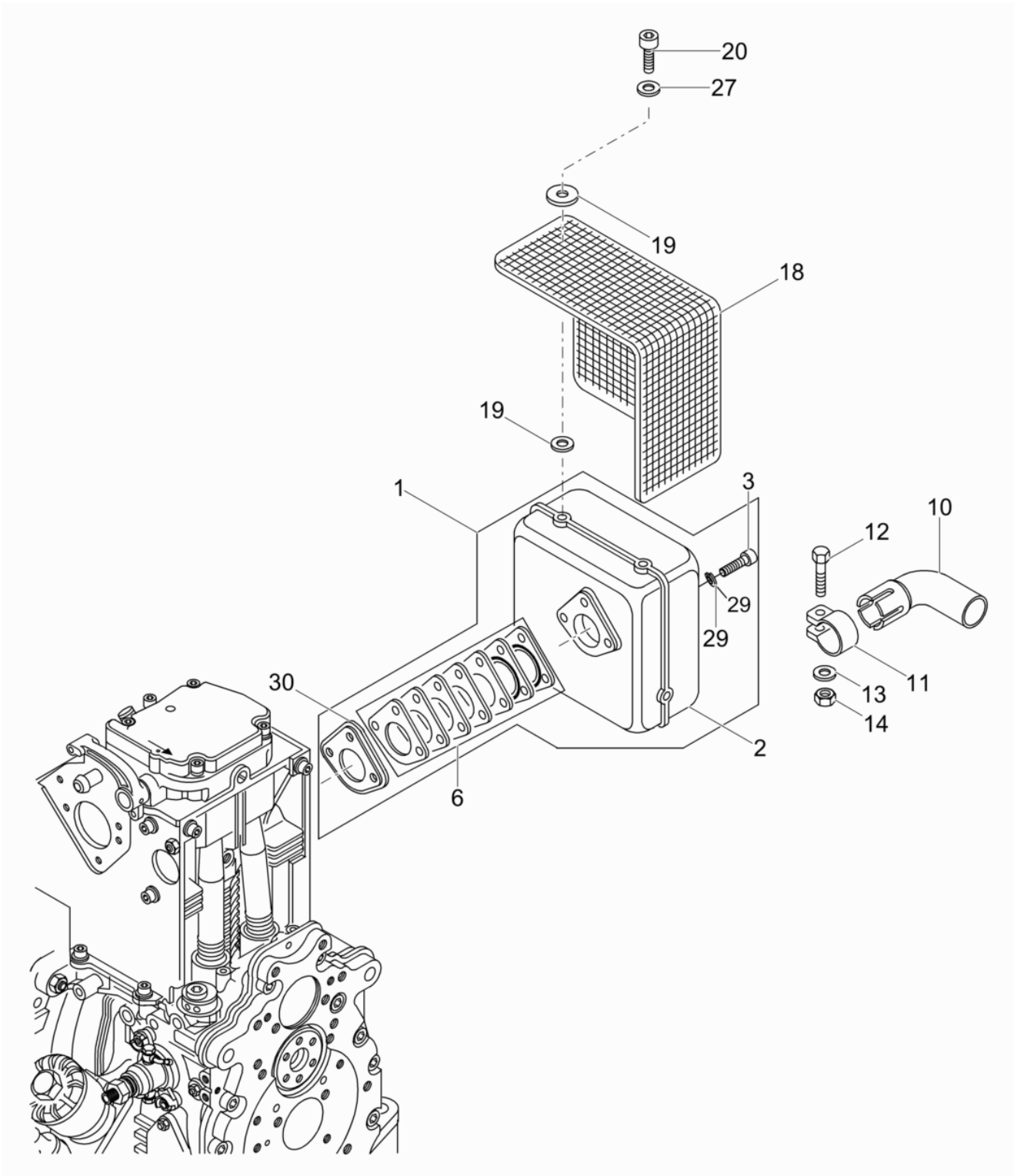

Ref. Pos.	Part No. Artikel Nr.	Qty. St.	Description Beschreibung	Descripción Description	Measurement./Abm.	Norm
					Torque/Drehm.	Sealant Schmierstoff
1	0104465	1	Muffler Auspuff	Escape Échappement		
3	0151578	3	Cheese head screw Zylinderschraube	Tornillo cilíndrico Vis à tête cylindrique	M8 x 30	ISO4762
6	0104464	1	Gasket set Dichtungssatz	Juego de juntas Jeu de joints		
10	0104467	1	Exhaust pipe Abgasrohr	Tubo de escape Tubulare d'evacuation		
11	0104468	1	Clamp Schelle	Abrazadera Collier		
12	0202452	1	Hexagonal head cap screw Sechskantschraube	Tornillo hexagonal Vis à tête hexagonale	M8 x 50	
13	0151553	1	Washer Scheibe	Arandela Rondelle	B8,4	ISO7089
14	0151530	1	Locknut Sechskantmutter	Contratuerca Contre-écrou	M8	
18	0104466	1	Contact safety device Berührungsschutz	Dispositivo de protección Grille de protection		
19	0099525	8	Washer Scheibe	Arandela Rondelle		
20	0202443	4	Cheese head screw Zylinderschraube	Tornillo cilíndrico Vis à tête cylindrique	M6 x 20	
27	0151540	4	Washer Scheibe	Arandela Rondelle	A6,4	DIN9021
30	0226593	1	Gasket Dichtung	Junta de estanqueidad Garniture		

Starting crank
Andrehkurbel

DPU5545Heh

Manivela de arranque
Manivelle de démarrage

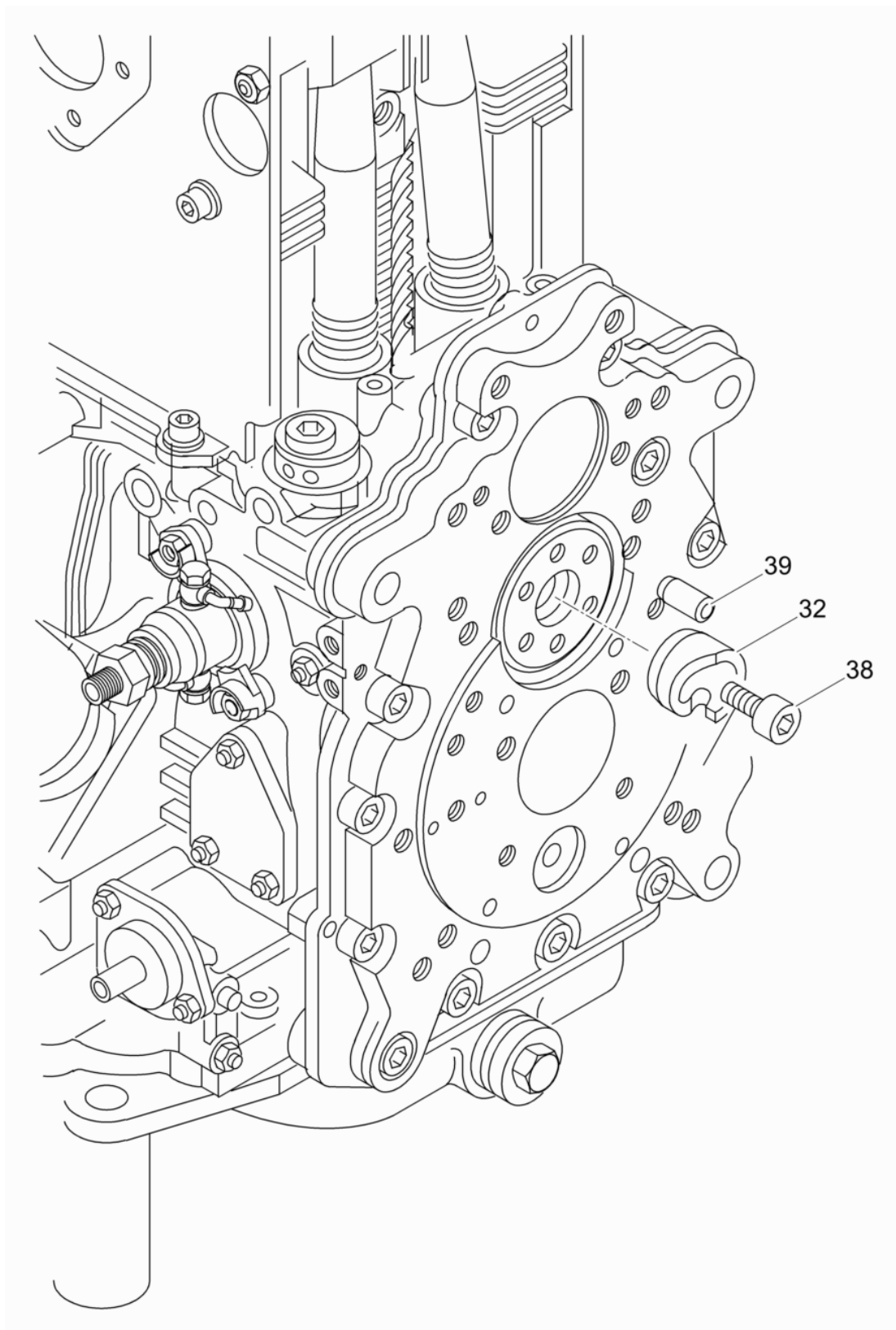

Ref. Pos.	Part No. Artikel Nr.	Qty. St.	Description Beschreibung	Descripción Description	Measurement./Abm.	Norm
					Torque/Drehm.	Sealant Schmierstoff
32	0097419	1	Starting jaw Andrehklaue	Garra de arranque Griffe de mise en marche		
34	0064065	1	Shim Ring Passscheibe	Arandela de Ajuste Disque D'Ajustage	10 x 16 x 1	DIN988
38	0201372	1	Hexagon socket head screw Innensechskantschraube	Tornillo a seis lados huecos Vis à six pans creux	M8x12	
39	0202453	1	Straight pin Zylinderstift	Pasador cilíndrico Goupille cylindrique		

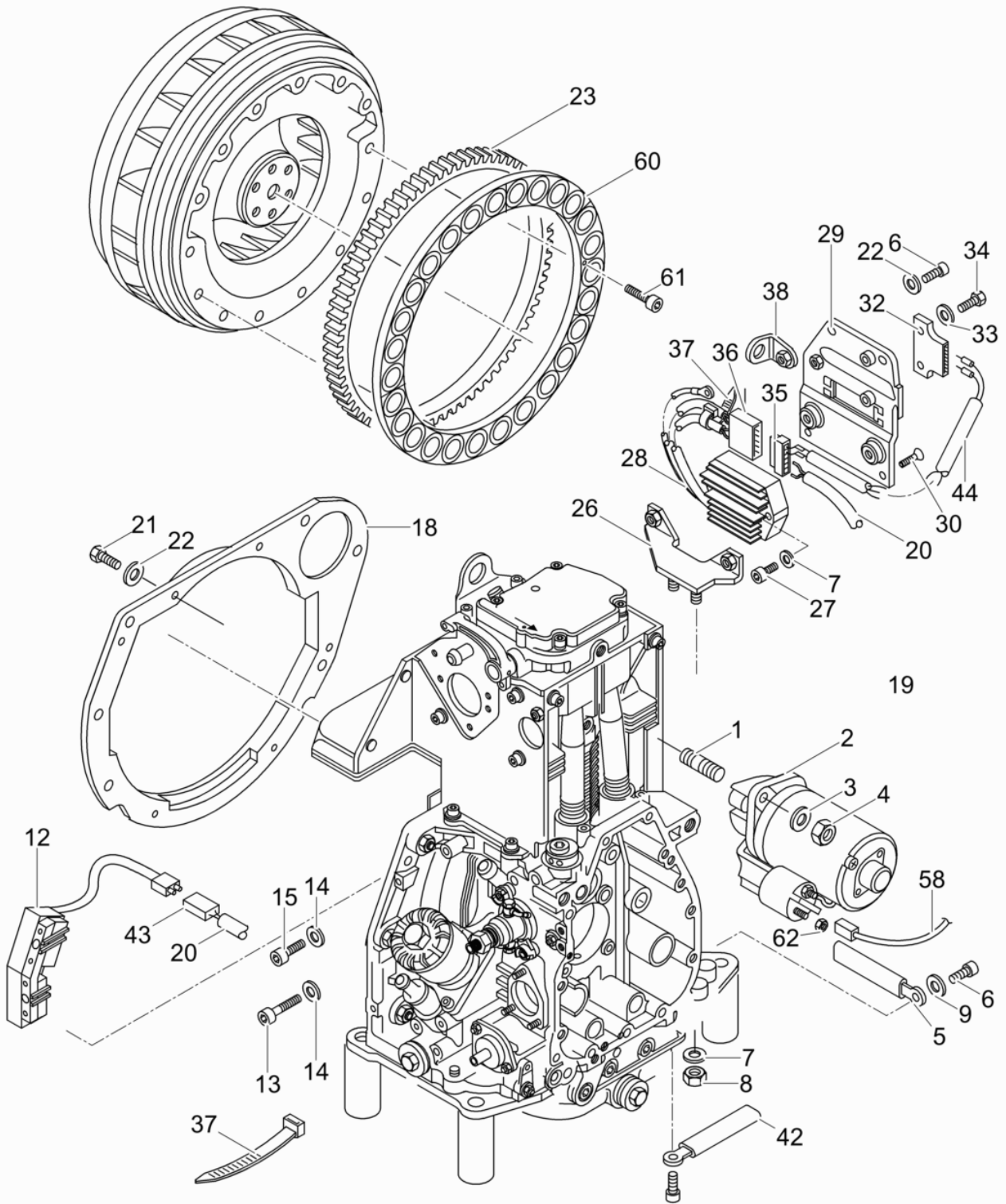

Ref. Pos.	Part No. Artikel Nr.	Qty. St.	Description Beschreibung	Descripción Description	Measurem./Abm.	Norm
					Torque/Drehm.	Sealant Schmierstoff
1	0203131	2	Threaded bolt Gewindebolzen	Perno roscado Boulon fileté	M12 x 50	
2	0129926	1	Starter Starter	Starter Starter		
3	0203132	2	Washer Scheibe	Arandela Rondelle	A13	
4	0097428	2	Hexagon nut Sechskantmutter	Tuerca hexagonal Écrou hexagonal		
5	0097590	2	Clamp Schelle	Abrazadera Agrafe		
6	0129016	2	Cheese head screw Zylinderschraube	Tornillo cilíndrico Vis à tête cylindrique	M6 x 12	ISO4762
7	0151218	4	Lock washer Federring	Arandela elástica Rondelle de ressort	8	
8	0151379	2	Locknut Sechskantmutter	Contratuerca Contre-écrou	M8	ISO4032
9	0151324	1	Washer Scheibe	Arandela Rondelle	6.4	
12	0129024	1	Coil Spule	Bobina Bobine		
13	0203133	1	Hexagon socket head screw Innensechskantschraube	Tornillo a seis lados huecos Vis à six pans creux	M6 x 25	
14	0207593	2	Spring washer Spannscheibe	Arandela elástica Disque de serrage		
15	0203134	1	Cheese head screw Zylinderschraube	Tornillo cilíndrico Vis à tête cylindrique	M6 x 30	
18	0104432	1	Baffle plate Trennblech	Placa separadora Separateur		
20	0207562	1	Electric wire Kabel	Cable eléctrico Fil ressortant		
21	0202436	5	Screw Schraube	Tornillo Vis	M6 x 12	
22	0151456	6	Lock washer Federring	Arandela elástica Rondelle de ressort	6	DIN128
23	0104430	1	Gear crown Zahnkranz	Corona dentada Coûroune		
26	0104435	1	Retainer Halter	Soporte Logement		
27	0202440	2	Hexagon socket head screw Innensechskantschraube	Tornillo a seis lados huecos Vis à six pans creux	M8x35	
28	0212093	1	Regulator Reglerschalter	Regulador Régulateur		
29	0097592	1	Plate Halteblech	Placa Plaque		
30	0151387	2	Countersunk screw Senkschraube	Tornillo avellanado Vis noyée	M6 x 12 14Nm/10ft.lbs	ISO10642
32	0095074	2	Connector Stiftstecker	Conector Connexion		
33	0129517	2	Washer Scheibe	Arandela Rondelle	A5,3	ISO7089

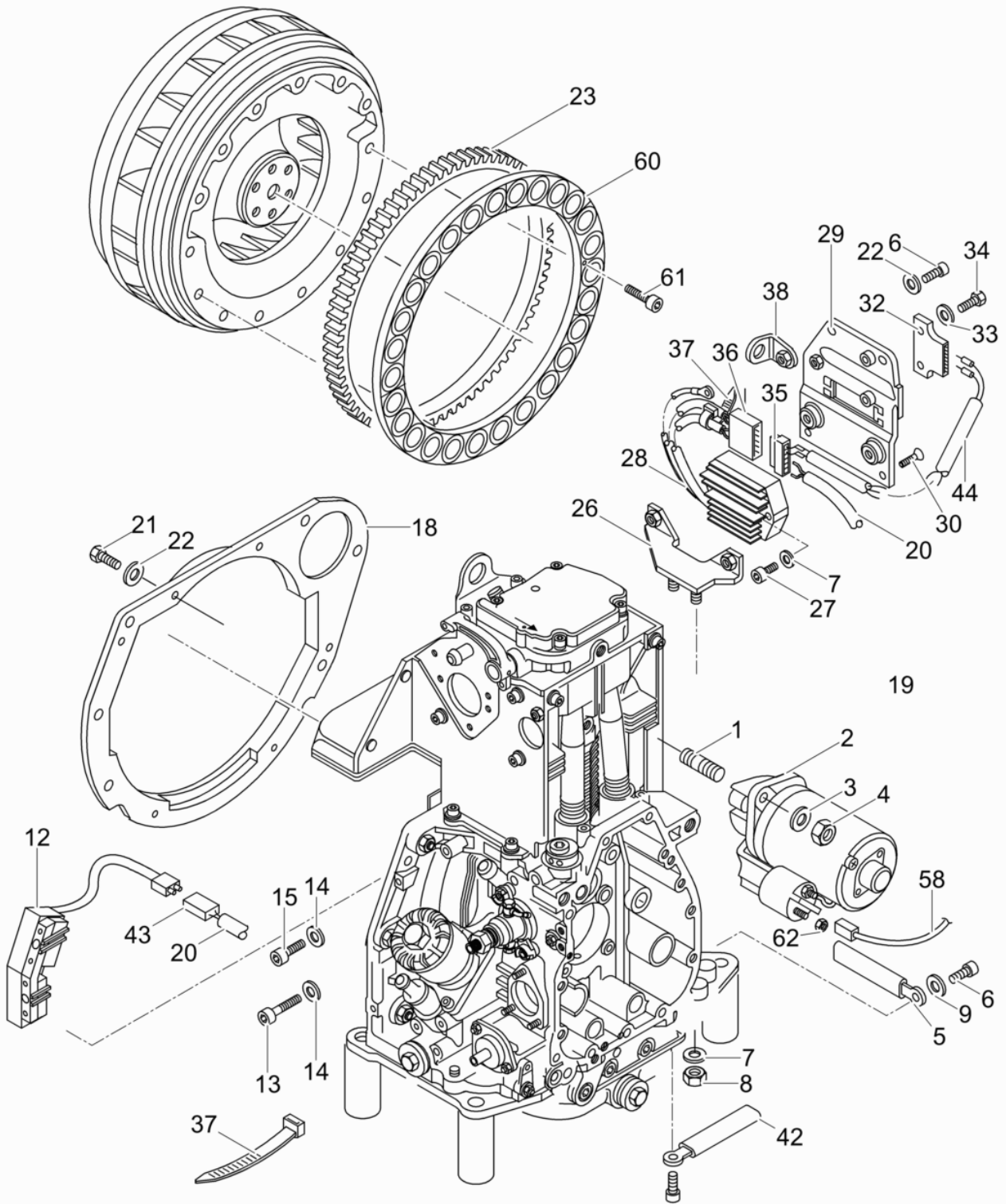

Ref. Pos.	Part No. Artikel Nr.	Qty. St.	Description Beschreibung	Descripción Description	Measurem./Abm.	Norm
					Torque/Drehm.	Sealant Schmierstoff
34	0207529	2	Cheese head screw Zylinderschraube	Tornillo cilíndrico Vis à tête cylindrique	M5 x 16	
35	0099522	1	Pin bushing Steckhülse	Tomacorriente Prise de courant		
36	0102713	1	Shock-proof plug Schukostecker	Enchufe con puesta a tierra Fiche	10A 250V	
37	0109710	4	Tie cable Kabelbinder	Fijación Attache		
38	0104436	1	Angle Winkel	Ángulo Coude		
42	0102472	2	Clamp Schelle	Abrazadera Collier		
43	0102471	1	Plug (threaded) Stecker	Enchufe Prise		
44	0102474	1	Cable Leitung	Cable Câble		
58	0095075	1	Cable Leitung	Cable Câble		
60	0129025	1	Magnetic ring Magnetring	Anillo magnética Bague magnétique		
61	0129026	12	Cheese head screw Zylinderschraube	Tornillo cilíndrico Vis à tête cylindrique	M4 x 16	ISO4762
62	0108848	1	Nut Mutter	Tuerca Écrou		

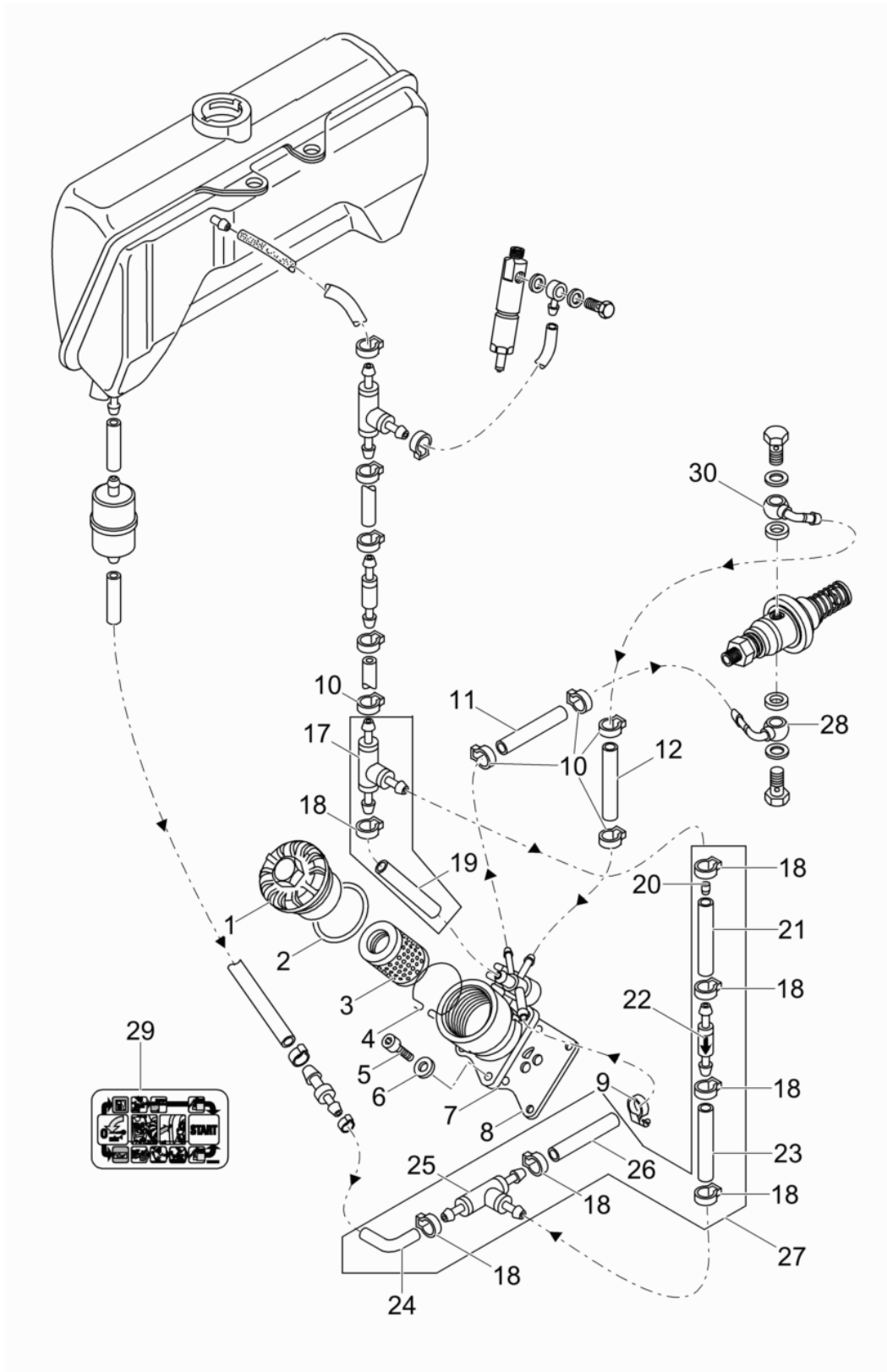

Ref. Pos.	Part No. Artikel Nr.	Qty. St.	Description Beschreibung	Descripción Description	Measurem./Abm.	Norm
					Torque/Drehm.	Sealant Schmierstoff
1	0094931	1	Cover Schraubdeckel	Tapa Couvercle		
2	0094928	1	Gasket Flachdichtring	Juntaaceite Joint		
3	0094930	1	Element Filterpatrone	Elemento Elément		
4	0104402	1	Spring Drahtfeder	Resorte Ressort		
5	0202437	4	Cheese head screw Zylinderschraube	Tornillo cilíndrico Vis à tête cylindrique	M6 x 20	
6	0151290	4	Spring washer Federscheibe	Arandela elástica Rondelle à ressort	A6	DIN137
7	0207531	1	Valve Absperrventil	Válvula de desconexión Soupape		
8	0106559	1	Seal Dichtung	Junta Joint		
9	0202469	1	Clamp Schlauchschelle	Abrazadera Agrafe		
10	0207586	5	Clamp Schlauchklemme	Abrazadera Collier de serrage		
11	0217102	1	Fuel hose Kraftstoffleitung	Manguera de combustible Tuyau à essence	4,5 x 200	
12	0217107	1	Fuel hose Kraftstoffleitung	Manguera de combustible Tuyau à essence	4,5 x 110	
17	0207810	1	T-piece T-Stück	Pieza T T-pièce		
18	0207586	7	Clamp Schlauchklemme	Abrazadera Collier de serrage		
19	0217104	1	Fuel hose Kraftstoffleitung	Manguera de combustible Tuyau à essence	4,5 x 30	
20	0207526	1	Valve Ventil	Válvula Soupape		
21	0217109	1	Fuel hose Kraftstoffleitung	Manguera de combustible Tuyau à essence	5,3 x 50	
22	0217093	1	Back pressure valve Rückschlagventil	Válvula de retención Soupape de retenue		
23	0217103	1	Fuel hose Kraftstoffleitung	Manguera de combustible Tuyau à essence	4,5 x 80	
24	0217106	1	Fuel hose Kraftstoffleitung	Manguera de combustible Tuyau à essence	4,5 x 35	
25	0106563	1	Tee-fitting T-Stück	Unión forma T Raccord "T"		
26	0217105	1	Fuel hose Kraftstoffleitung	Manguera de combustible Tuyau à essence	4,5 x 50	
27	0207518	1	Fuel pipe cpl. Kraftstoffleitung kpl.	Pipa del combustible cpl. Pipe du combustible cpl.		
28	0207525	1	Screw nipple Anschraubnippel	Boquilla roscada Raccord de vissage		
29	0226595	1	Labels Aufkleber	Calcomanias Autocollants		

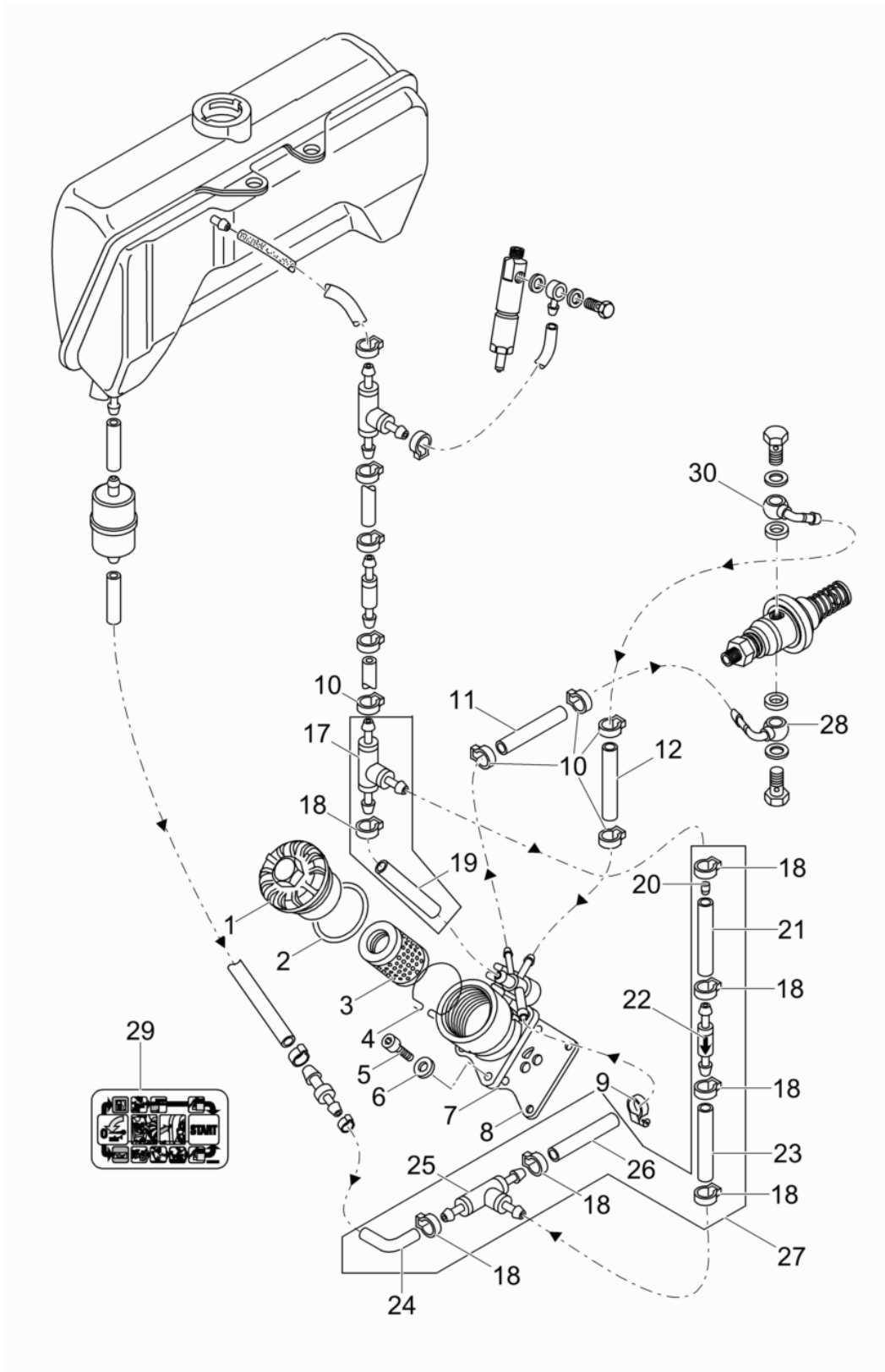

Ref. Pos.	Part No. Artikel Nr.	Qty. St.	Description Beschreibung	Descripción Description	Measurement./Abm.	Norm
					Torque/Drehm.	Sealant Schmierstoff
30	0207809	1	Screw nipple Anschraubnippel	Boquilla roscada Raccord de vissage		

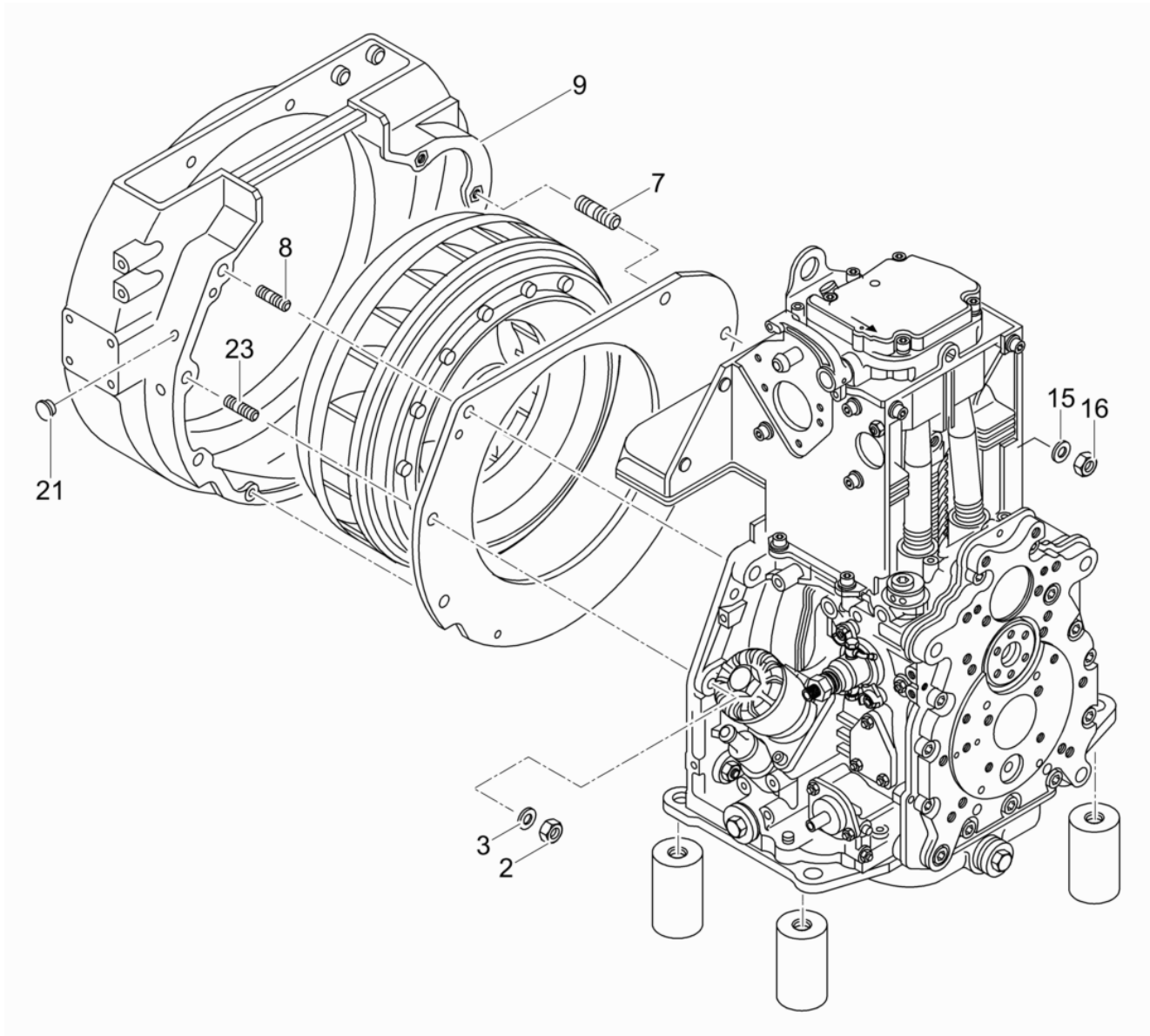

Ref. Pos.	Part No. Artikel Nr.	Qty. St.	Description Beschreibung	Descripción Description	Measurement./Abm.	Norm
					Torque/Drehm.	Sealant Schmierstoff
2	0207819	4	Hexagon nut Sechskantmutter	Tuerca hexagonal Écrou hexagonal	M10	
3	0202434	4	Washer Scheibe	Arandela Rondelle	10,5	
4	0202338	2	Hexagonal head cap screw Sechskantschraube	Tornillo hexagonal Vis à tête hexagonale	M6 x 16	DIN933
5	0151456	2	Lock washer Federring	Arandela elástica Rondelle de ressort	6	DIN128
7	0203131	2	Threaded bolt Gewindebolzen	Perno roscado Boulon fileté	M12 x 50	
8	0207816	3	Stud Stiftschraube	Perno prisionero Boulon	M10 x 35	
9	0104425	1	Coupling housing Anschlußgehäuse	Caja de conexión Carter de branchement		
15	0203132	2	Washer Scheibe	Arandela Rondelle	A13	
16	0097428	2	Hexagon nut Sechskantmutter	Tuerca hexagonal Écrou hexagonal		
21	0207605	2	Push-in plug Verschlußstopfen	Tapón Bouchon		
23	0207817	1	Stud Stiftschraube	Perno prisionero Boulon	M10 x 45	

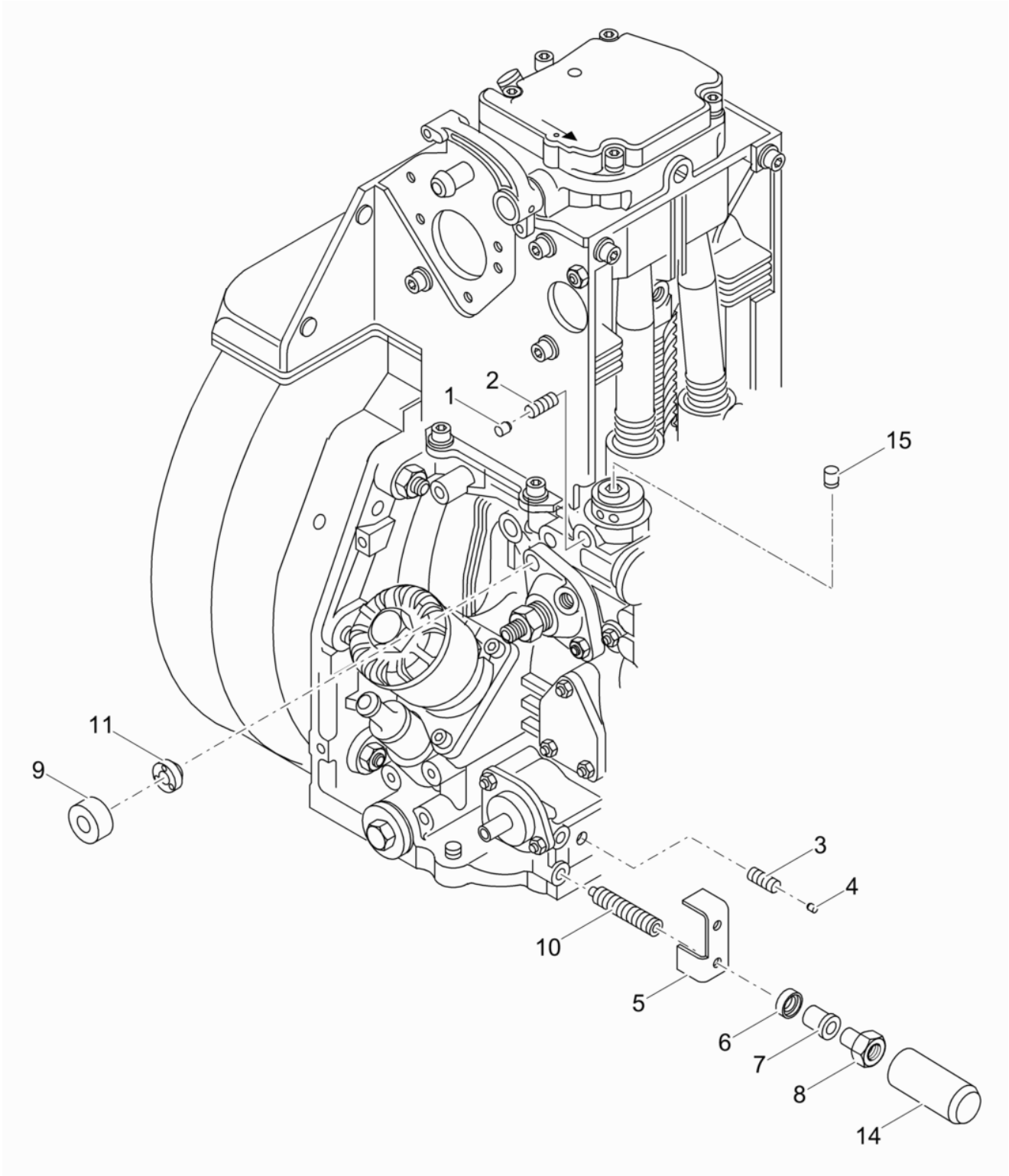

Ref. Pos.	Part No. Artikel Nr.	Qty. St.	Description Beschreibung	Descripción Description	Measurement./Abm.	Norm
					Torque/Drehm.	Sealant Schmierstoff
1	0207603	1	Push-in plug Verschlußstopfen	Tapón Bouchon		
2	0020348	1	Threaded pin Gewindestift	Varilla roscada Goupille fileté	M8 x 16	DIN916
3	0202456	1	Threaded pin Gewindestift	Varilla roscada Goupille fileté	M8 x 20	
4	0207604	1	Push-in plug Verschlußstopfen	Tapón Bouchon		
5	0126904	1	Angle Winkel	Ángulo Coude		
6	0126905	1	Washer Scheibe	Arandela Rondelle		
7	0126906	1	Bush Buchse	Buje Boîte		
8	0126907	1	Threaded bush Gewindebuchse	Casquillo roscado Boîte tarandée	M6	
9	0207567	2	Cap Kappe	Tapa Couvercle		
10	0126909	2	Threaded pin Gewindestift	Varilla roscada Goupille fileté		
11	0207587	2	Counternut Sicherheitsmutter	Tuerca de seguridad Ecrou de sécurité		
14	0126911	1	Cap Kappe	Tapa Chapeau		
15	0207602	1	Push-in plug Verschlußstopfen	Tapón Bouchon		

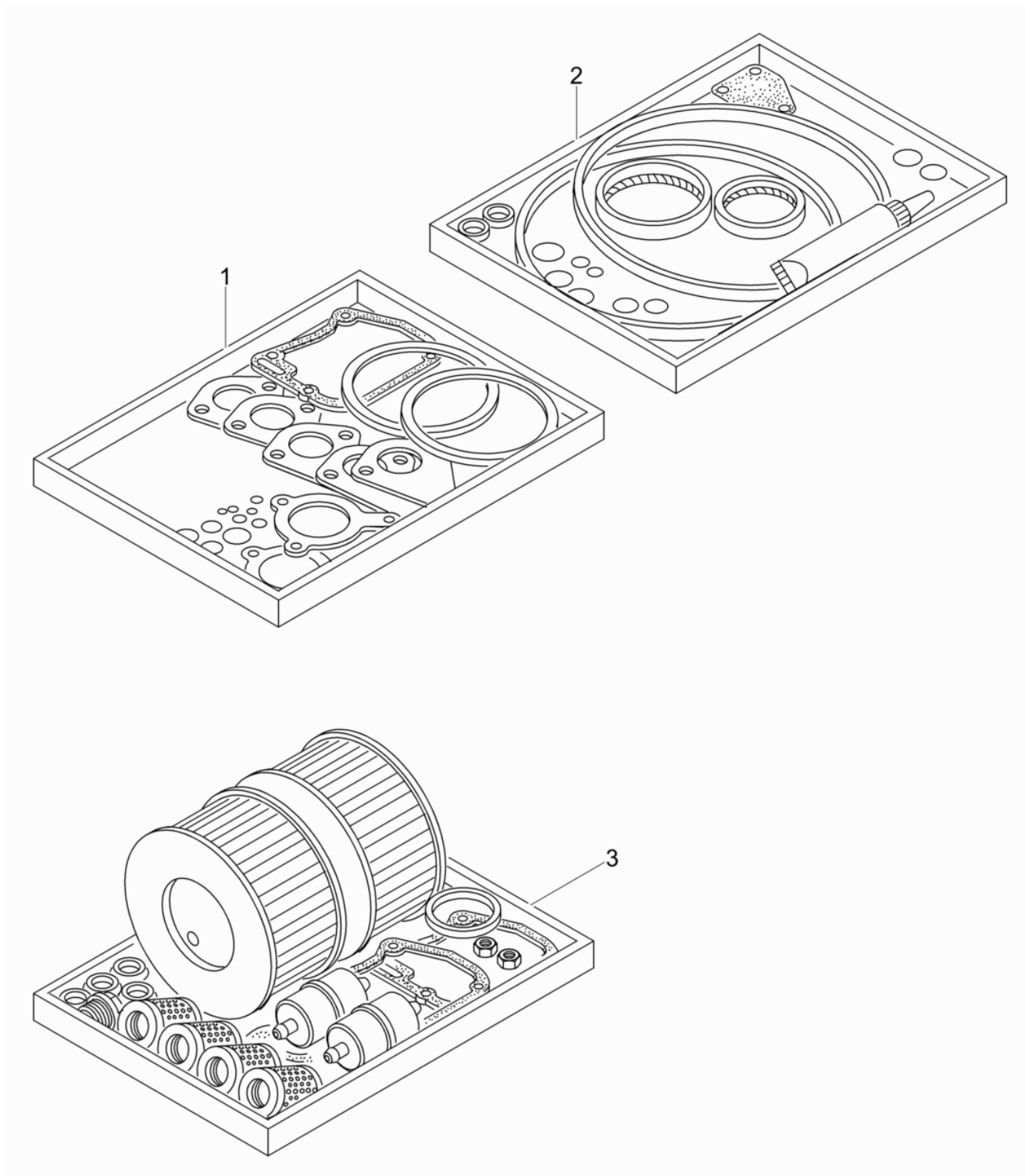

Ref. Pos.	Part No. Artikel Nr.	Qty. St.	Description Beschreibung	Descripción Description	Measurem./Abm.	Norm
					Torque/Drehm.	Sealant Schmierstoff
1	0104361	1	Gasket Set Dichtungssatz	Juego de Juntas Jeu de Joints		
2	0104362	1	Gasket set - Crankcase Dichtungssatz - Kurbelgehäuse	Juego de juntas - Carter Jeu de joints - Carter		
3	0207775	1	Maintenance set Wartungssatz	Juego para mantenimiento Jeu d'entretien		



**WACKER
NEUSON**

**Accessoires
Zubehör
Accesorios
Accessories**

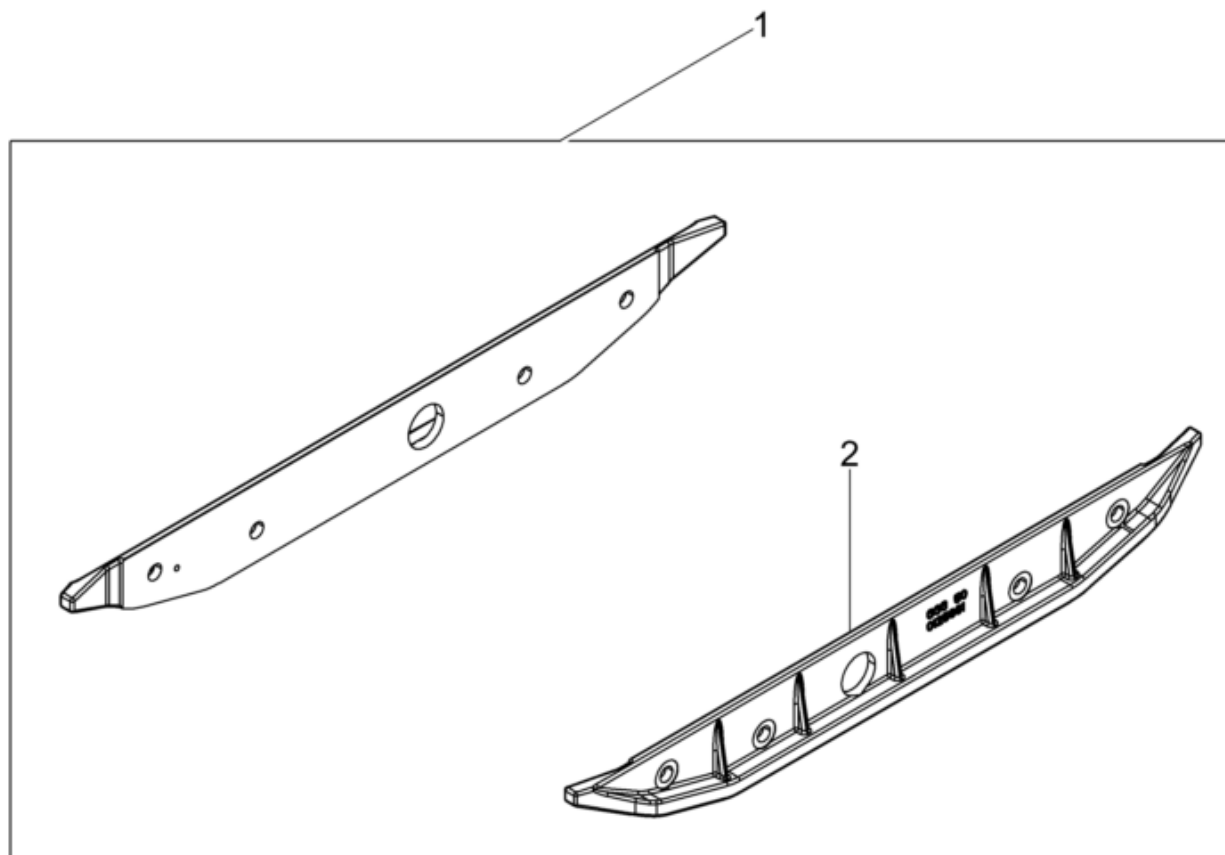

Ref. Pos.	Part No. Artikel Nr.	Qty. St.	Description Beschreibung	Descripción Description	Measur./Abm.	Norm
					Torque/Drehm.	Sealant Schmierstoff
1	0126290	1	Extension plate kit Anbauplattensatz	Juego de placa de extensión Jeu de elargisseur	3	
2	0125662	2	Extension plate Anbauplatte	Placa de extensión Elargisseur	3 cm	

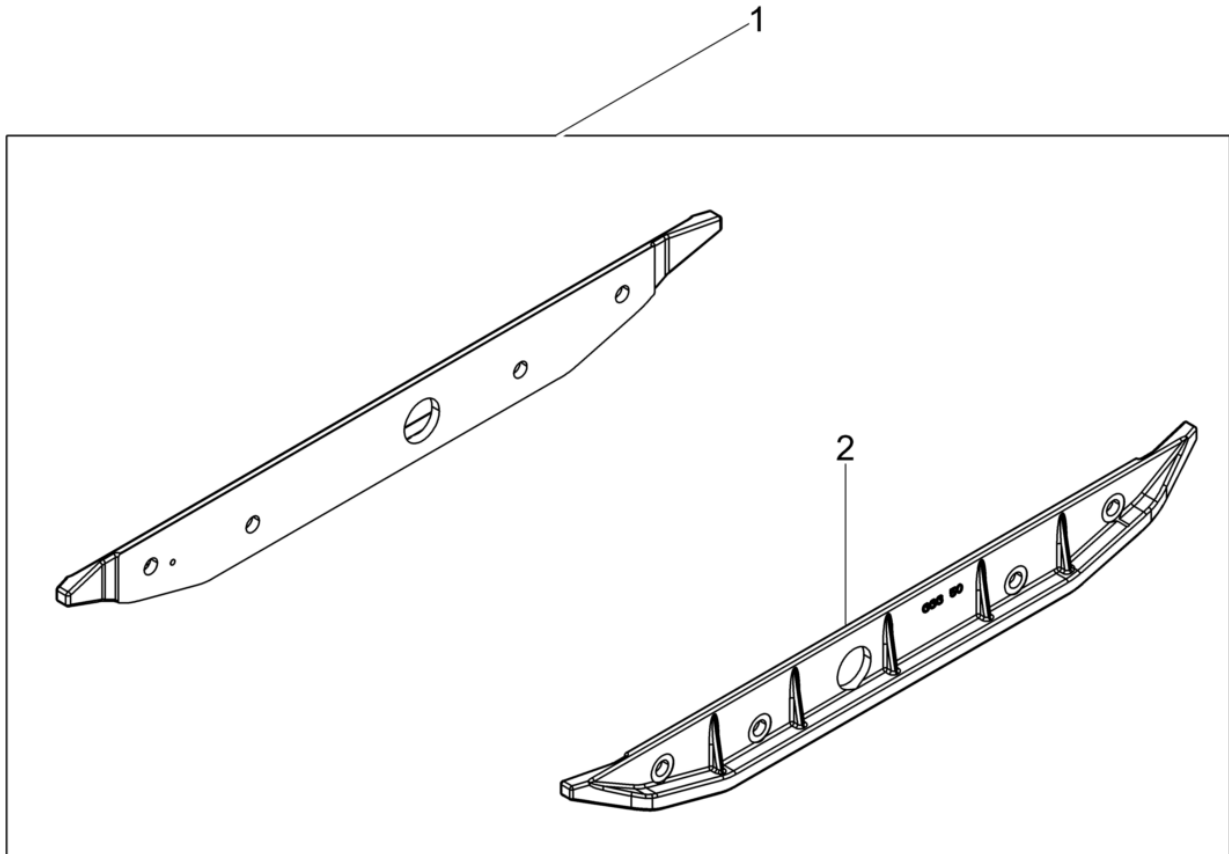

Ref. Pos.	Part No. Artikel Nr.	Qty. St.	Description Beschreibung	Descripción Description	Measur./Abm.	Norm
					Torque/Drehm.	Sealant Schmierstoff
1	0045201	1	Extension plate kit Anbauplattensatz	Juego de placa de extensión Jeu de elargisseur	3in	
2	0044442	2	Extension plate Anbauplatte	Placa de extensión Elargisseur	8 cm	

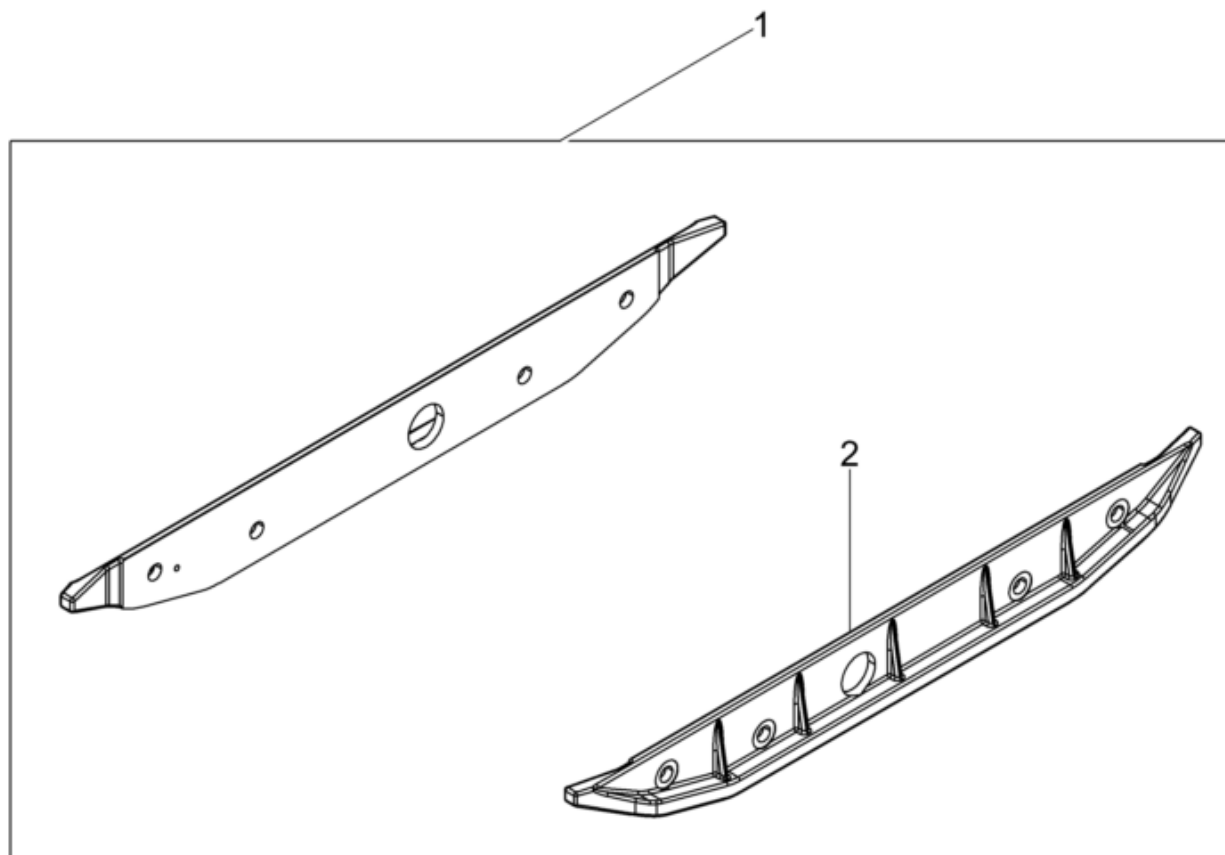

Ref. Pos.	Part No. Artikel Nr.	Qty. St.	Description Beschreibung	Descripción Description	Measur./Abm.	Norm
					Torque/Drehm.	Sealant Schmierstoff
1	0043246	1	Extension plate kit Anbauplattensatz	Juego de placa de extensión Jeu de elargisseur	15	
2	0043245	1	Extension plate Anbauplatte	Placa de extensión Elargisseur	860mm	

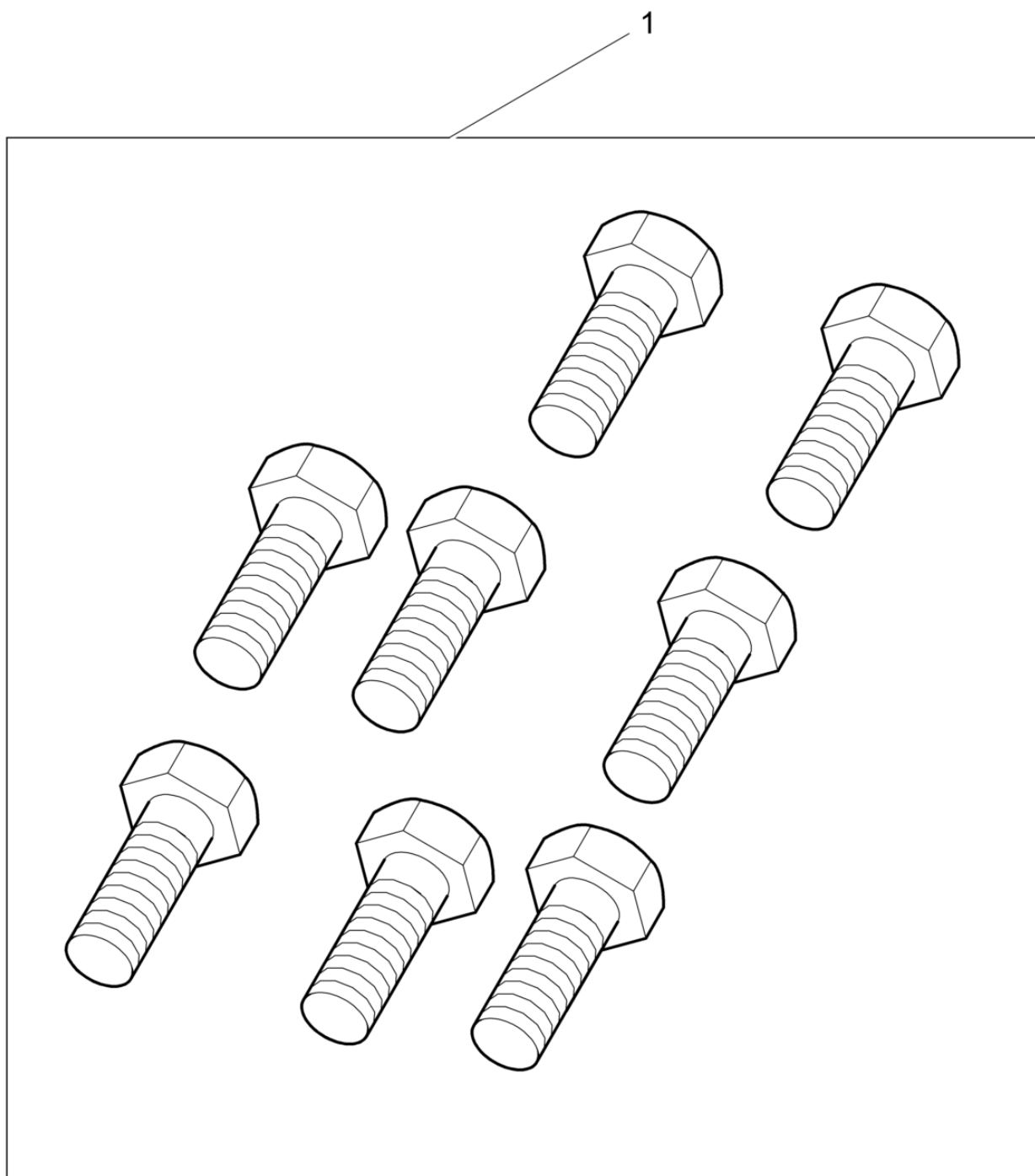

DPU5545Heh

Set of screws
Schraubensatz
Juego de tornillos
Jeu de vis

Ref. Pos.	Part No. Artikel Nr.	Qty. St.	Description Beschreibung	Descripción Description	Measurement./Abm.	Norm
					Torque/Drehm.	Sealant Schmierstoff
1	0067519	1	Set of screws Schraubensatz	Juego de tornillos Jeu de vis		

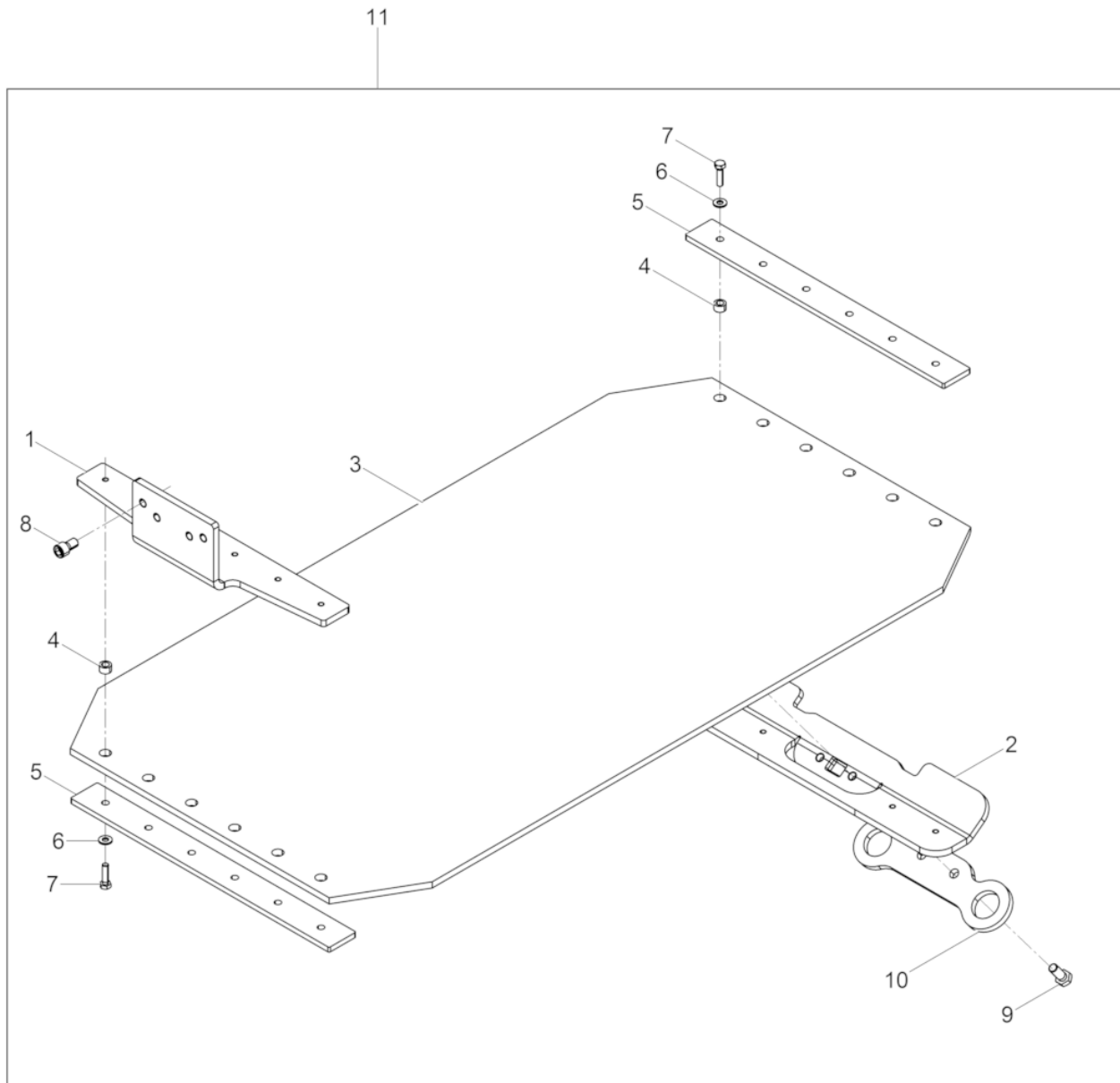

Ref. Pos.	Part No. Artikel Nr.	Qty. St.	Description Beschreibung	Descripción Description	Measurement/Abm.	Norm
					Torque/Drehm.	Sealant Schmierstoff
1	0202884	1	Angle Winkel	Angulo Angle		
2	5100010936	1	Angle rear Winkel hinten	Angulo atrás Angle arrière		
3	0058330	1	urethane plate Kunststoffplatte	Juego de lamina de uretano Dispositif de glissement		
4	0047577	10	Bushing Buchse	Buje Douille		
5	0058358	2	Bar Leiste	Listón Listeau		
6	0033198	10	Lockwasher Spannscheibe	Arandela elástica Rondelle de ressort	8	DIN6796
7	0011456	10	Hexagonal head cap screw Sechskantschraube	Tornillo hexagonal Vis à tête hexagonale		
8	0011531	4	Cheese head screw Zylinderschraube	Tornillo cilíndrico Vis à tête cylindrique	M12 x 20 86Nm/63ft.lbs	ISO4762
9	0011423	2	Hexagonal head cap screw Sechskantschraube	Tornillo hexagonal Vis à tête hexagonale	M12 x 30 210Nm/155ft.lbs	DIN933
10	5100010935	1	Plate Blech	Chapa Tôle		
11	5100009997	1	Urethane Pad PGV 4045-5545 Gleitvorrichtung	Placa de DeslizamientoPGV 4045-5545 Jeu de Tapis en Polyuréthane		

Starting crank
Andrehkurbel

DPU5545Heh

Manivela de arranque
Manivelle de démarrage

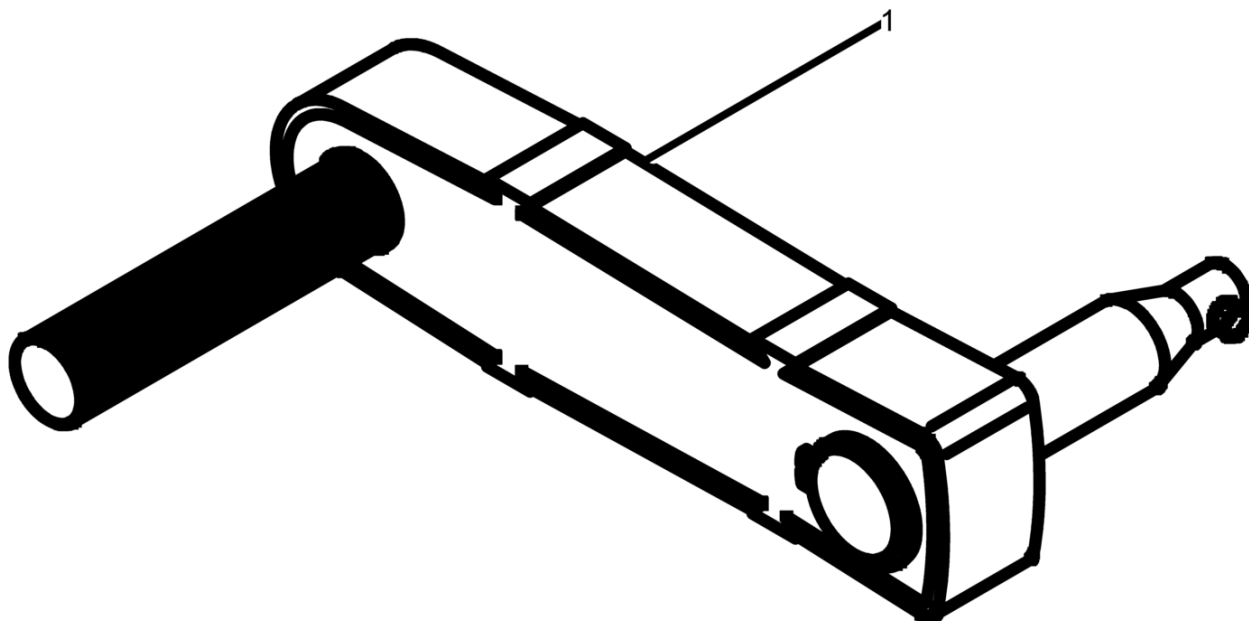

DPU5545Heh

Starting crank
Andrehkurbel
Manivela de arranque
Manivelle de démarrage

Ref. Pos.	Part No. Artikel Nr.	Qty. St.	Description Beschreibung	Descripción Description	Measurement./Abm.	Norm
					Torque/Drehm.	Sealant Schmierstoff
1	0104081	1	Starting crank Andrehkurbel rückschlagsicher	Manivela de arranque Manivelle de démarrage		

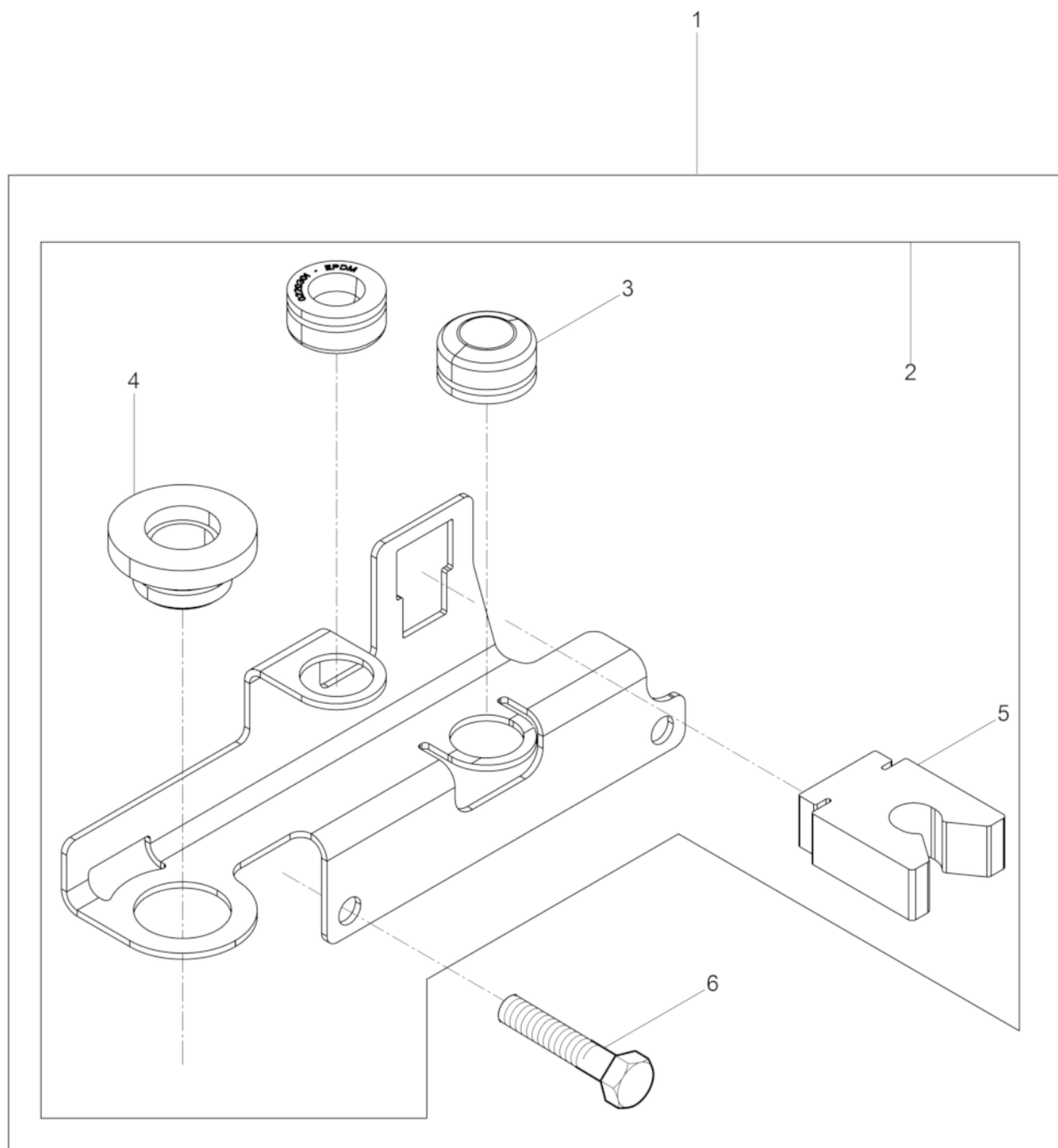

Ref. Pos.	Part No. Artikel Nr.	Qty. St.	Description Beschreibung	Descripción Description	Measurement./Abm.	Norm
					Torque/Drehm.	Sealant Schmierstoff
1	0220474	1	Kit-mounting-Starting crank Anbausatz	Juego-instalación-Manivela de arranque Jeu de montage-Manivelle de		
2	0220377	1	Crank holder Kurbelhalter	Porta-manivela Support manivelle		
3	0220301	2	Shockmount Puffer	Amortiguador Silentbloc		
4	0220300	1	Bush Gummibuchse	Buje Boîte		
5	0220239	1	Bracket Halterung	Soporte Équerre		
6	0011421	2	Hexagonal head cap screw Sechskantschraube	Tornillo hexagonal Vis à tête hexagonale	M12 x 40 86Nm/63ft.lbs	DIN933

Trolley cpl.
Fahrgestell kpl.
Dispositivo de Transporte cpl.
Chassis cpl.

DPU5545Heh

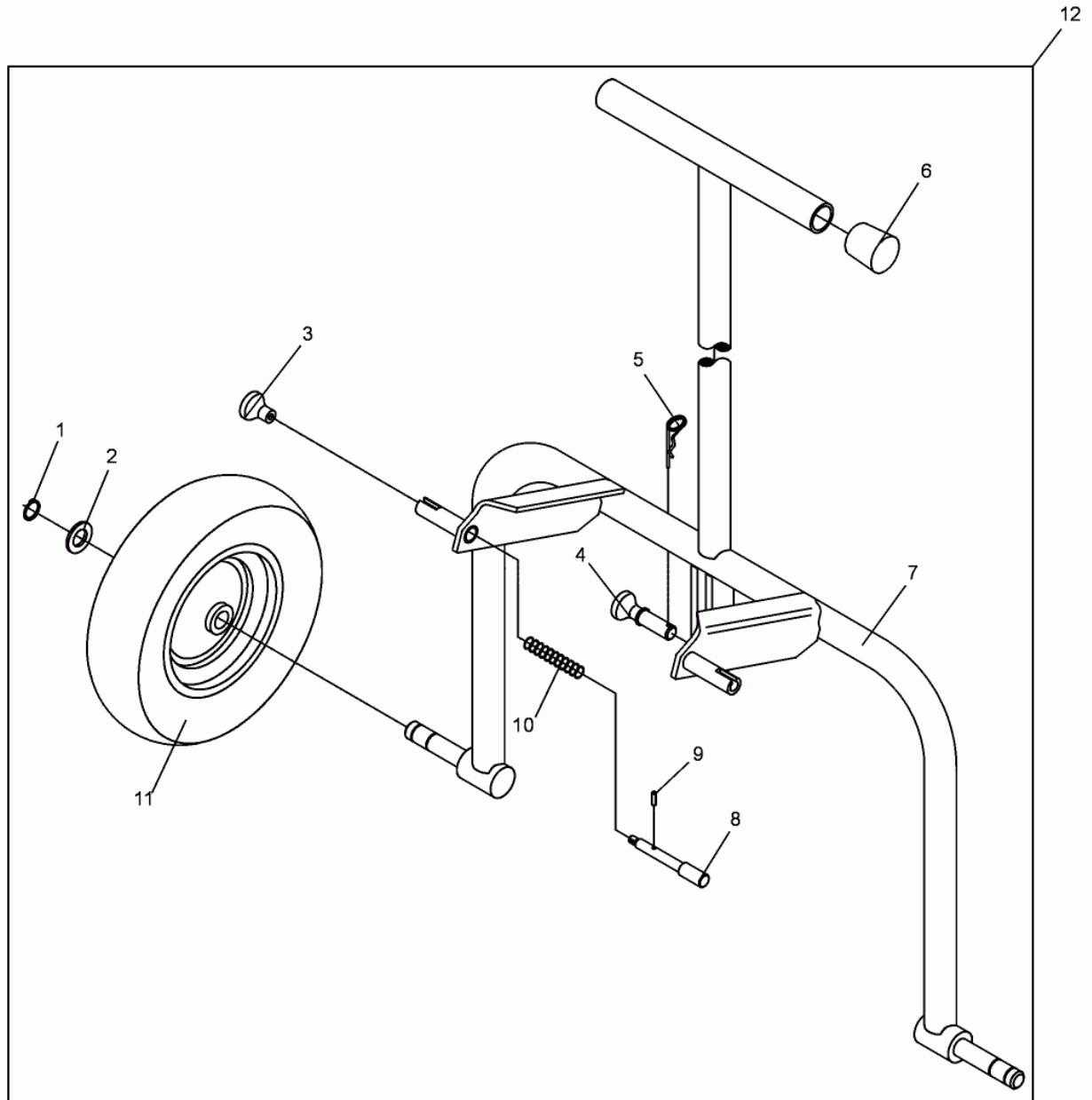

Ref. Pos.	Part No. Artikel Nr.	Qty. St.	Description Beschreibung	Descripción Description	Measurem./Abm.	Norm
					Torque/Drehm.	Sealant Schmierstoff
1	2001041	2	Retaining ring Sicherungsring	Anillo de retención Bague d'arrêt	25 x 1,2	DIN471
2	0010614	2	Flat washer Scheibe	Arandela Rondelle	24	ISO7090
3	0033621	2	Switch handle Flacher Knopf	Empuñadura Poignée d'interrupteur		
4	0048121	1	Bolt cpl. Absteckbolzen kpl.	Pasador cpl. Boulon cpl.		
5	0031312	1	Detent spring Vorsteckfeder	Resorte Ografe	3	
6	0067826	2	Protective cap Schutzkappe	Capa de protección Chape de protection		
7	0102220	1	Trolley Fahrgestell	Dispositivo de transporte Chassis		
8	0048042	2	Bolt Bolzen	Perno Boulon		
9	0010397	2	Spring pin Spannstift	Pasador de sujeción Goupille élastique	5 x 20	DIN1481
10	0033476	2	Compression spring Druckfeder	Resorte de compresión Ressort de pression	D-186	DIN2098
11	0048057	2	Tire Rad	Rueda Roue		
12	0102219	1	Trolley cpl. Fahrgestell kpl.	Dispositivo de transporte cpl. Chassis cpl.		

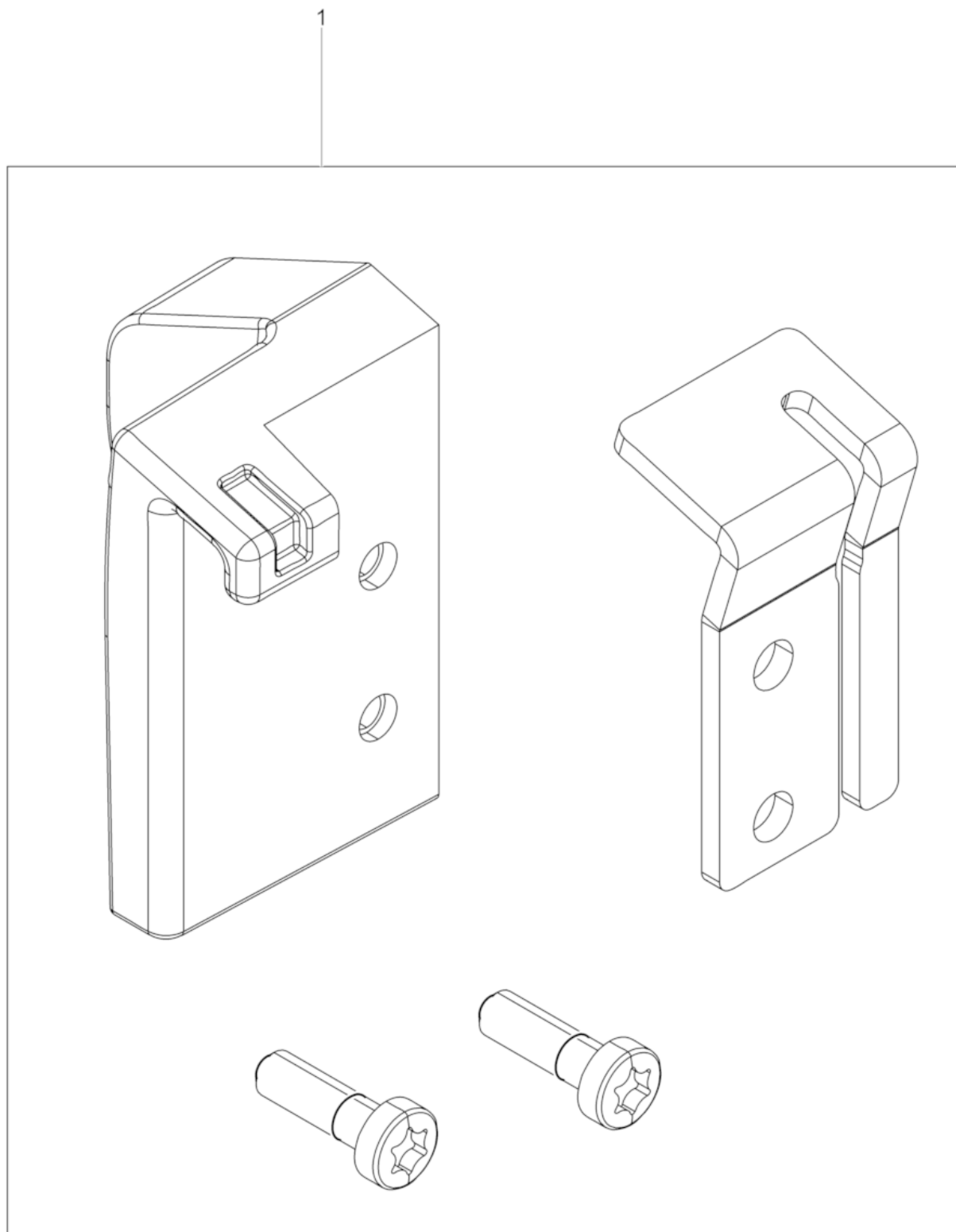

DPU5545Heh

Kit-retrofit belt guide
Nachrüstsatz Riemenberuhiger
Juego de modificaciónguía de correa
Lot de rattrapage

Ref. Pos.	Part No. Artikel Nr.	Qty. St.	Description Beschreibung	Descripción Description	Measurem./Abm.	Norm
					Torque/Drehm.	Sealant Schmierstoff
1	5100005821	1	Kit-retrofit belt guide Nachrüstsatz Riemenberuhiger	Juego de modifigúa de correa Lot de rattrapag		

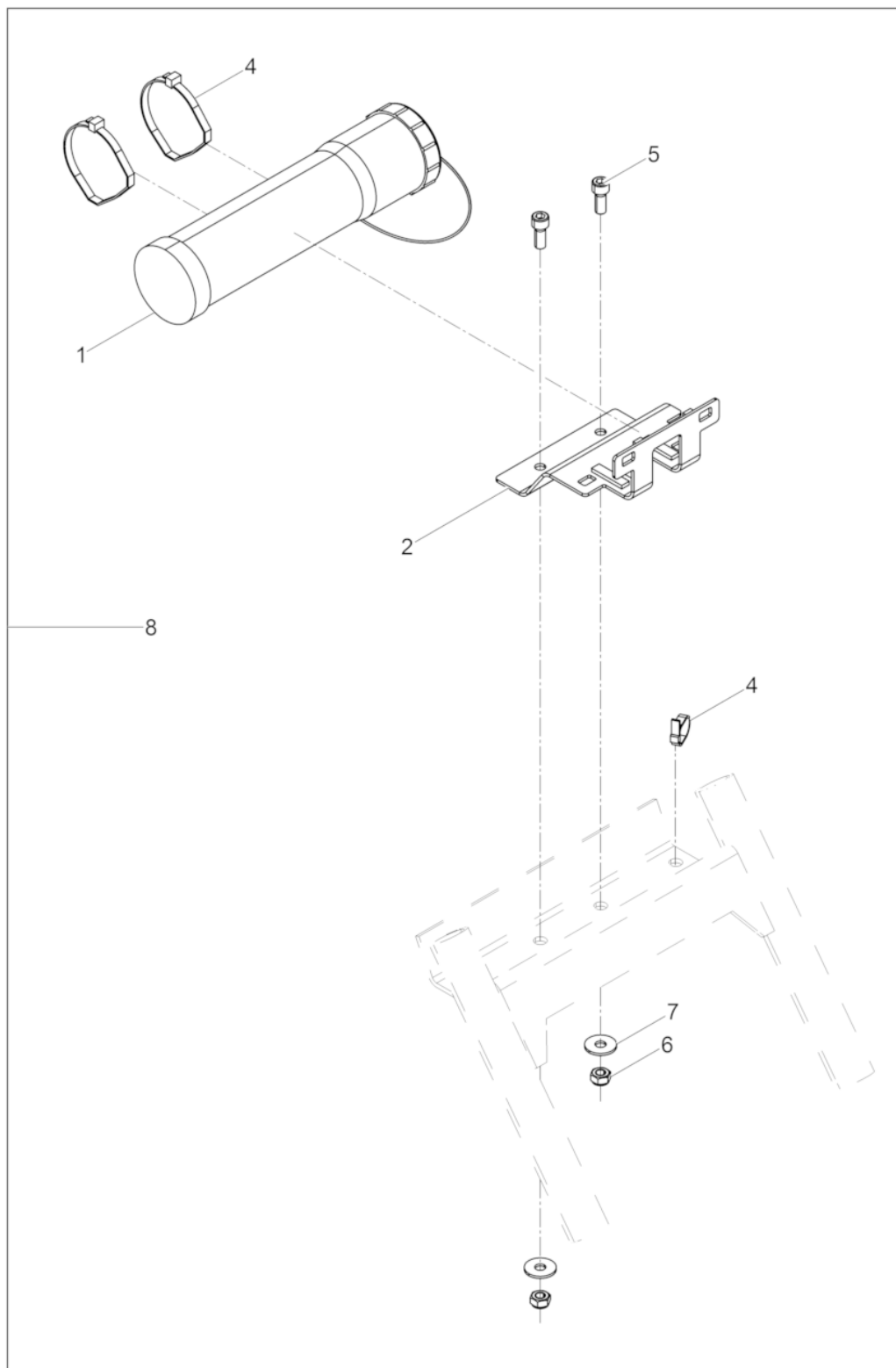

Ref. Pos.	Part No. Artikel Nr.	Qty. St.	Description Beschreibung	Descripción Description	Measurem./Abm.	Norm
					Torque/Drehm.	Sealant Schmierstoff
1	5100026895	1	Document-Box Dokumentenbehälter	Saporte posa documentos Receptable de documents		
2	5100028391	1	Bracket Halterung	Soporte Équerre		
4	0047388	3	Cable yarn Kabelbinder	Fijación de cables Attache de câble		
5	0011535	2	Cheese head screw Zylinderschraube	Tornillo cilíndrico Vis à tête cylindrique	49Nm/36ft.lbs	
6	0017313	2	Hexagon nut Sechskantmutter	Tuerca hexagonal Écrou hexagonal		
7	0010375	2	Flat washer Scheibe	Arandela Rondelle	B10,5	DIN9021
8	5100028390	1	Kit-retrofit DPU40../45../55.. Nachrüstsatz Rental DPU40../45../55..	Juego de modificación DPU40../45../55.. Lot de rattrapage		



**WACKER
NEUSON**