



**WACKER
NEUSON**

Ersatzteilkatalog
Spare parts list
Catalogo de piezas de repuesto
Catalogue des pièces détachées

Vibrationsplatte
Vibratory plate
Plancha vibratoria
Plaque vibrante

DPU 375OHTS



Type	DPU 375OHTS
Material Number	5000610321
Version	102
Language	de en es fr



www.wackerneuson.com

Copyright © 2019
Wacker Neuson Produktion GmbH & Co. KG
Printed in Germany.
All rights reserved.

Ein Typenschild mit Typ, Artikelnummer, Version und Maschinen-Nummer ist an jedem Gerät angebracht. Die Daten von diesem Schild bitte notieren, damit sie auch bei Verlust oder Beschädigung des Schildes noch vorhanden sind. Der Typ, die Artikelnummer, die Versions-Nummer und die Maschinen-Nummer sind bei der Ersatzteilbestellung oder Nachfragen bezüglich Service-Informationen stets erforderlich.

Bei den in den Ersatzteillisten fettgedruckten Nummern handelt es sich um empfohlene Ersatzteile. Dies bedeutet, daß diese Teile bei normalen Anwendungsbedingungen natürlicher Abnutzung ausgesetzt sind und gelegentlich ersetzt oder überarbeitet werden müssen. Es wird geraten, diese Teile auf Lager bereit zu haben, um für Service-Arbeiten an diesem Gerät vorbereitet zu sein. Lagerbestände für diese und andere Teile, welche für ausgiebigere Reparaturarbeiten benötigt werden, können je nach Service-Gewohnheiten der einzelnen Kunden variieren.

Die Nummern meines Gerätes sind:

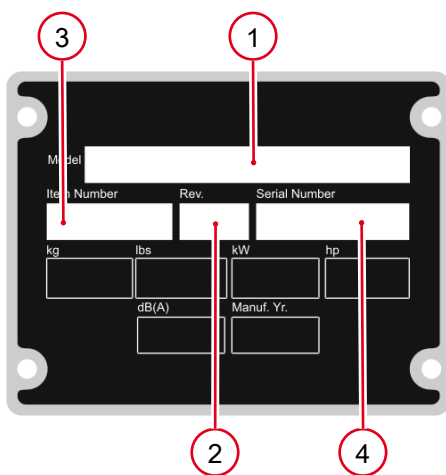

1. Typ
2. Version
3. Artikel-Nr.
4. Maschinen-Nr.

Umrechnungstabelle

Volumeneinheit	
1 ml	0.034 US fl.oz.
1 l	0.260 gal
Längeneinheit	
1 mm	0.039 in
1 m	3.280 ft
Gewicht	
1 kg	2.200 lbs
1 g	0.035 oz
Geschwindigkeit	
1 km/h	0.620 mph
Drehmoment	
1 Nm	0.740 ft.lbs

A nameplate listing the Model Number, Item Number, Revision, and Serial Number is attached to each unit. Please record the information found on this plate so it will be available should the nameplate become lost or damaged. When ordering parts or requesting service information, you will always be asked to specify the model, item number, revision number, and serial number of the unit.

Part Numbers appearing in boldface type are recommended spare parts. This means that these parts are subject to wear under normal operating conditions and may require periodic service or replacement. It is recommended that these items be stocked to meet the expected service requirements of this model. Actual stocking quantities of these and other parts used in more extensive repairs will depend on the service practices of each customer.

My machine's numbers are:

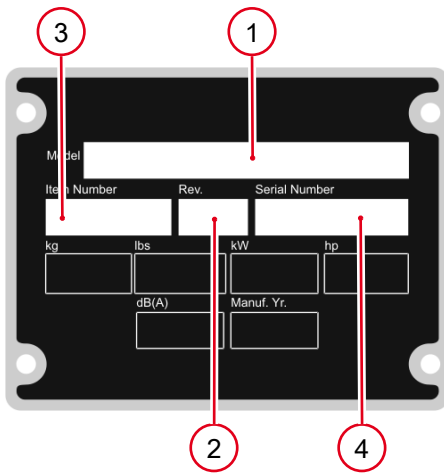

1. Model
2. Revision
3. Item No.
4. Serial No.

Conversion table

Volume unit	
1 ml	0.034 US fl.oz.
1 l	0.260 gal
Unit of length	
1 mm	0.039 in
1 m	3.280 ft
Weight	
1 kg	2.200 lbs
1 g	0.035 oz
Speed	
1 km/h	0.620 mph
Torque	
1 Nm	0.740 ft.lbs

Una placa de identificación con el modelo, número de referencia, nivel de revisión y número de serie ha sido añadida en cada máquina. Favor de anotar los datos en la placa en caso de que la placa de identificación sea destruida o perdida. En todos los pedidos para repuestos necesita siempre el modelo, el número de referencia, el nivel de revisión y el número de serie de la máquina en cuestión.

Los números de partes en negritas en las Listas Ilustradas de Partes son los repuestos recomendados, esto quiere decir que estas partes se desgastarán bajo circunstancias de funcionamiento normales y pueden requerir servicio periódico o su reemplazo. Se recomienda que el cliente mantenga un abastecimiento adecuado de estas partes para poder satisfacer la demanda requerida por el servicio a la máquina. La cantidad de repuestos que el cliente necesitará para reparaciones dependerá de la póliza de servicio de cada cliente.

Los números de mi máquina son:

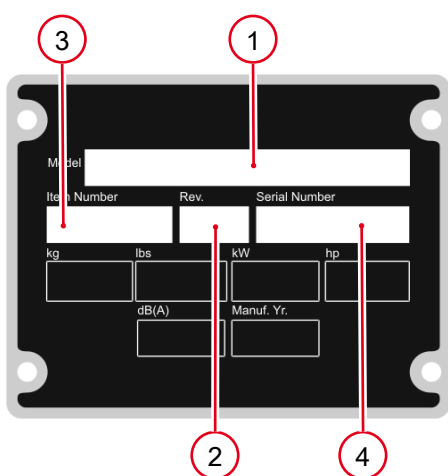

1. Modelo
2. Nivel de revisión
3. Número de referencia
4. Número de Serie

Tabla de conversión

Unidad de volumen	
1 ml	0.034 US fl.oz.
1 l	0.260 gal
Unidad de longitud	
1 mm	0.039 in
1 m	3.280 ft
Peso	
1 kg	2.200 lbs
1 g	0.035 oz
Velocidad	
1 km/h	0.620 mph
Par de apriete	
1 Nm	0.740 ft.lbs



Une plaque signalétique mentionnant le modèle, le numéro de référence, le niveau de revision et le numéro de série est fixée sur chaque machine. Veuillez noter les informations relevées sur cette plaque de façon à ce qu'elles soient toujours disponibles si la plaque signalétique venait à être perdue ou endommagée. Lorsque vous commandez des pièces détachées ou vous sollicitez des informations après-vente, on vous demandera toujours de préciser le modèle, le numéro de référence, le niveau de revision et le numéro de série de la machine.

Les numéros de pièces imprimés en caractères gras dans les Listes des Pièces Détachées de ce manuel sont les pièces détachées recommandées par la Wacker. Cela veut dire que ces pièces sont sujettes à usure dans des conditions de travail normales et peuvent nécessiter de l'entretien ou leur remplacement. Nous recommandons que vous disposiez d'un stock de ces pièces pour pouvoir satisfaire la demande d'entretien de cette machine. Le client doit décider lui-même de la quantité exacte de pièces de rechange qu'il disposera dans ses stocks.

Les numéros de ma machine sont :

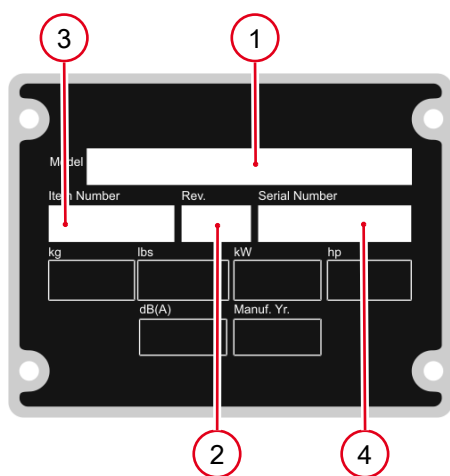

1. Typ
2. Version
3. Artikel-Nr.
4. Maschinen-Nr.

Table de conversion

Unité de volume	
1 ml	0.034 US fl.oz.
1 l	0.260 gal
Unité de longueur	
1 mm	0.039 in
1 m	3.280 ft
Poids	
1 kg	2.200 lbs
1 g	0.035 oz
Vitesse	
1 km/h	0.620 mph
Couple de serrage	
1 Nm	0.740 ft.lbs

Vibrationsplatte
Vibration Plate
Plancha Vibradora
Plaque Vibrante 8

Vibrationsplatte
Vibration Plate
Plancha Vibradora
Plaque Vibrante 12

Erreger
Exciter
Excitador
Excitatrice 14

Motor Kpl.
Engine Complete
Motor Compl.
Moteur Compl. 18

Fliehkraftkupplung Kpl.
Centrifugal Clutch Cpl.
Embrague Centrifugo Cpl.
Embrayage Centrifuge Cpl. 20

Deichsel Kpl.
Center Pole Cpl.
Barra De Mando Cpl.
Timon Cpl. 22

Deichselkopf Kpl.
Center Pole Head Cpl.
Cabezal De Mando Cpl.
Tête De Timon Cpl. 24

Aufkleber
Labels
Calcomanias
Autocollants 26

Zubehör
Accessories
Accesorios
Accessoires

Abschleppöse Kpl.
Towing Eye Cpl.
Ojete De Remolque Cpl.
Oeillet Cpl. 28

Pflastergleitvorrichtung Pgv 50
Urethane Pad Kit Pgv50
Placa De Deslizamiento Pgv50
Jeu De Tapis En Polyuréthane 30



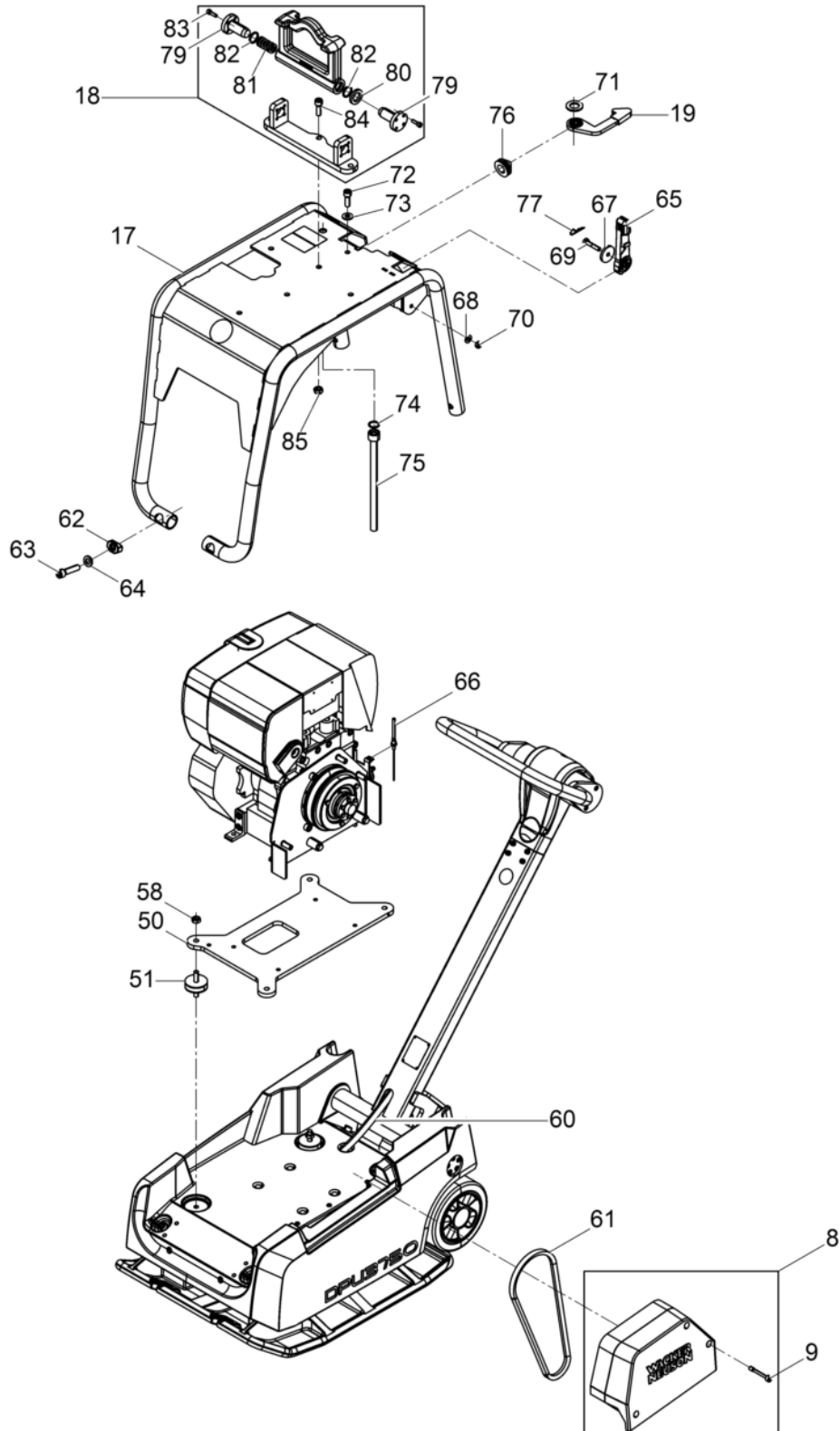

Pos. Ref.	Artikel Nr. Part No.	Qty.	Unit	Beschreibung Descripción	Description Description	Abm. Measur.	Norm Standard
						Drehm. Torque	Schmierstoff Sealant
8	5100002781	1	PC	Riemenschutz Protección de la polea	Belt guard Protection de courroie		
9	5000216659	3	PC	Dünnschaftschraube Tornillo	Screw Vis	M 8x 55	
17	5000200635	1	PC	Schutzrahmen Armazón de protección	Protective frame Cadre protection		
18	5000220230	1	PC	Kranöse kpl. Ojete para grua cpl.	Jack ring cpl. Oeillet cpl.		
19	5000200616	1	PC	Klaue kpl. Garra cpl.	Carrier cpl. Griffe cpl.		
50	5000212634	1	PC	Motorträger Montaje del motor	Engine support Montage du moteur		
51	5000216555	4	PC	Puffer Amortiguador	Shockmount Silentbloc		
58	5000010883	4	PC	Sechskantmutter Tuerca hexagonal	Hexagon nut Écrou hexagonal		
60	5000125357	1	PC	Schlauchleitung Conducto flexible	Hose pipe Conduite flexible		
61	5000216557	1	PC	Schmalkeilriemen Correa en v angosta	Narrow v-belt Trapezoidale étroite		
62	5000125949	4	PC	Bolzen Perno	Bolt Boulon		
63	5000013569	4	PC	Zylinderschraube Tornillo cilíndrico	Cheese head screw Vis à tête cylindrique	M12 x 50 86Nm/63ft.lbs	ISO4762
64	5000021465	4	PC	Sicherungsscheibe Arandela de seguridad	Lock washer Rondelle d'arrêt	HS12	
65	5000203537	1	PC	Regulierhebel Palanca reguladora	Governor lever Lever régulateur		
66	5000125348	1	PC	Bowdenzug Cable bowden	Bowden cable Câble bowden		
67	5000105194	1	PC	Scheibe Arandela	Washer Rondelle	M8 x 1,5in	
69	5000011341	1	PC	Sechskantschraube Tornillo hexagonal	Hexagonal head cap screw Vis à tête hexagonale	M8 x 40 25Nm/18ft.lbs	DIN931
70	5000033356	1	PC	Sechskantmutter Tuerca hexagonal	Hexagon nut Écrou hexagonal		
71	5000010616	1	PC	Scheibe Arandela	Flat washer Rondelle		
72	5000011534	1	PC	Zylinderschraube Tornillo cilíndrico	Cheese head screw Vis à tête cylindrique	M10 x 30 49Nm/36ft.lbs	ISO4762
73	5000033988	1	PC	Spannscheibe Arandela elástica	Lockwasher Rondelle de ressort	10	DIN6796
74	5000021483	1	PC	O-ring Anillo-o	O-ring Bague-o	16,3 x 2,4	
75	5000097318	1	PC	Ablaufstutzen Empalme	Adapter Raccord		
76	5000200617	1	PC	Puffer Tope	Shockmount Tampon		
77	5000129272	1	PC	Federstecker Enchufe de resorte	Spring pin Fiche		
80	5000216586	1	PC	Reibscheibe Disco de fricción	Friction disc Disque à friction		
81	5000220231	1	PC	Druckfeder Resorte de compresión	Compression spring Ressort de pression		
82	5000017254	2	PC	O-ring Anillo-o	O-ring Bague-o		

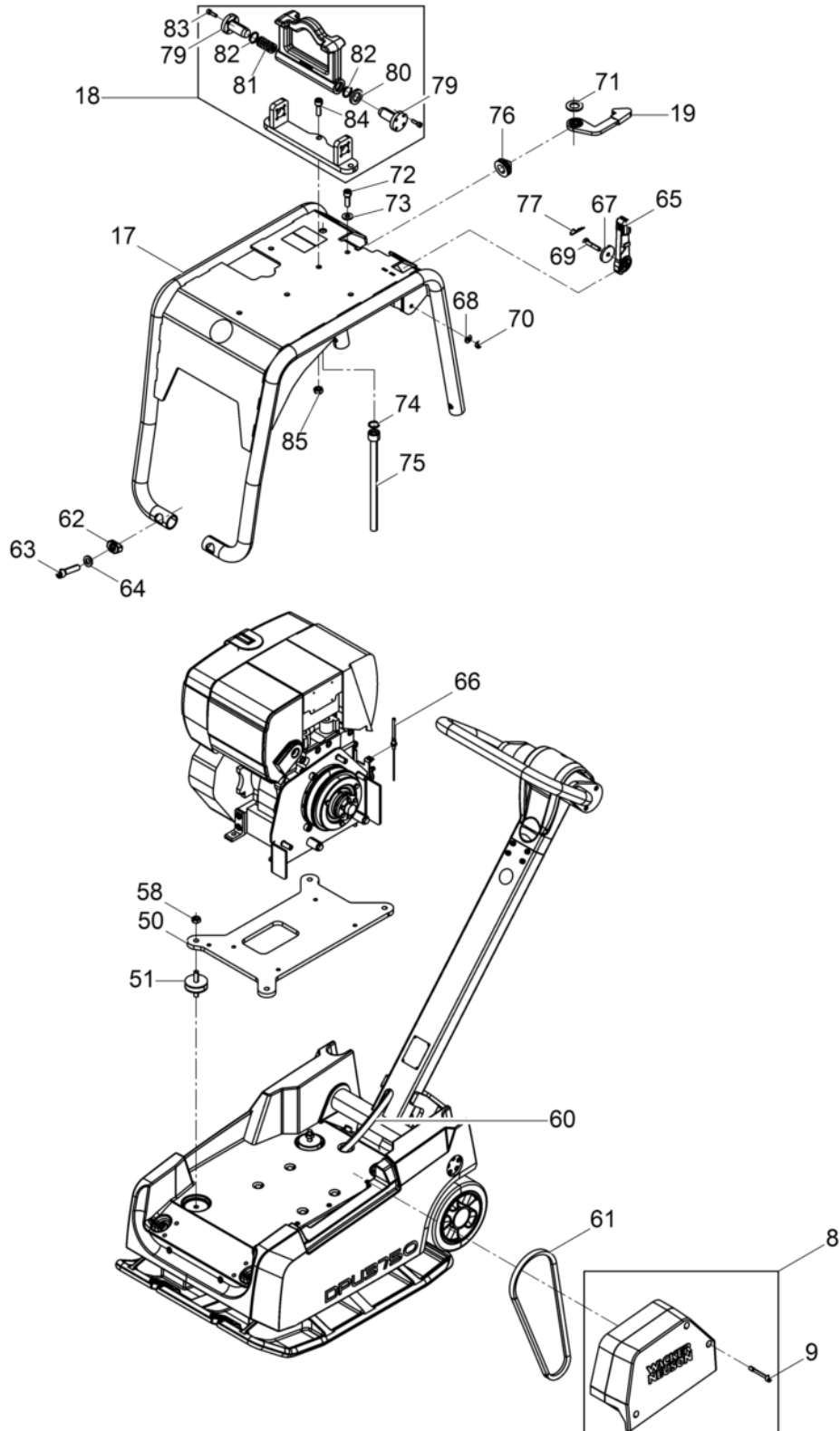

Pos. Ref.	Artikel Nr. Part No.	Qty.	Unit	Beschreibung Descripcion	Description Description	Abm. Measuram.	Norm Standard
						Drehm. Torque	Schmierstoff Sealant
83	5000011551	8	PC	Zylinderschraube Tornillo cilíndrico	Cheese head screw Vis à tête cylindrique	10Nm/7ft.lbs	
84	5000220226	3	PC	Zylinderschraube Tornillo cilíndrico	Cheese head screw Vis à tête cylindrique	M10x 30	ISO4762
85	5000216588	3	PC	Sechskantmutter Tuerca hexagonal	Hexagon nut Écrou hexagonal	M10	DIN980

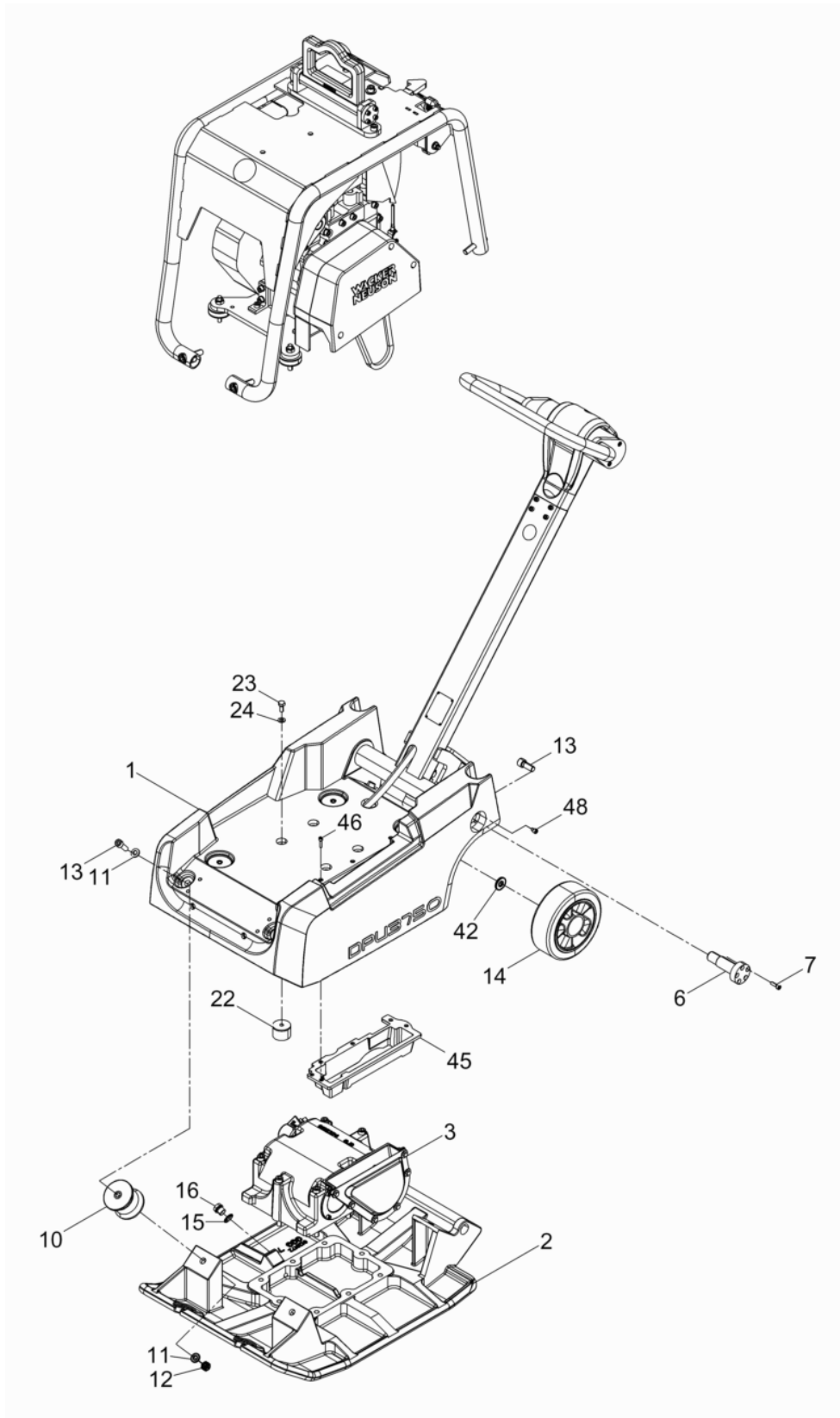

Pos. Ref.	Artikel Nr. Part No.	Qty.	Unit	Beschreibung Description	Description Description	Abm. Measur.	Norm Standard
						Drehm. Torque	Schmierstoff Sealant
1	5000220058	1	PC	Obermasse Masa superior	Upper mass Massa superieure		
2	5000126173	1	PC	Grundplatte Plancha-basa	Baseplate Base		
3	5000220070	1	PC	Erreger kpl. Excitador cpl.	Exciter cpl. Excitateur cpl.		
6	5000204120	2	PC	Achse Eje	Axle Axe		
7	5000011551	8	PC	Zylinderschraube Tornillo cilíndrico	Cheese head screw Vis à tête cylindrique	10Nm/7ft.lbs	
10	5000125931	4	PC	Gummi-metall-puffer Tope caucho-metal	Shockmount Tampon metallique oscillant		
11	5000010620	8	PC	Scheibe Arandela	Flat washer Rondelle	12	ISO7090
12	5000010884	4	PC	Sechskantmutter Tuerca hexagonal	Hexagon nut Écrou hexagonal	M12	DIN934
13	5000011529	6	PC	Zylinderschraube Tornillo cilíndrico	Cheese head screw Vis à tête cylindrique	M12 x 30 86Nm/63ft.lbs	ISO4762
14	5000125927	2	PC	Laufrad Rueda de rodadura	Tire Roue		
15	5000014968	1	PC	Usit-ring Anillo-usit	Usit-ring Bague-usit	16,7 x 24 x 1,5	
16	5000011034	1	PC	Verschlusschraube Tapón roscado	Plug (threaded) Bouchon	M16 x 1,5	DIN910
22	5000201017	4	PC	Anschlagpuffer Amortiguador	Shockmount Silentbloc		
23	5000013551	4	PC	Sechskantschraube Tornillo hexagonal	Hexagonal head cap screw Vis à tête hexagonale	M8 x 18 25Nm/18ft.lbs	DIN933
24	5000010622	4	PC	Scheibe Arandela	Flat washer Rondelle		
42	5000031565	2	PC	Spannscheibe Arandela elástica	Lockwasher Rondelle de ressort	12	DIN6796
45	5000201876	1	PC	Steinschutz Guardapiedras	Stone guard Grille de protection		
46	5000108180	6	PC	Zylinderschraube Tornillo cilíndrico	Cheese head screw Vis à tête cylindrique	M5 x 25	ISO4762
48	5000014425	2	PC	Zylinderschraube Tornillo cilíndrico	Cheese head screw Vis à tête cylindrique	10Nm/7ft.lbs	

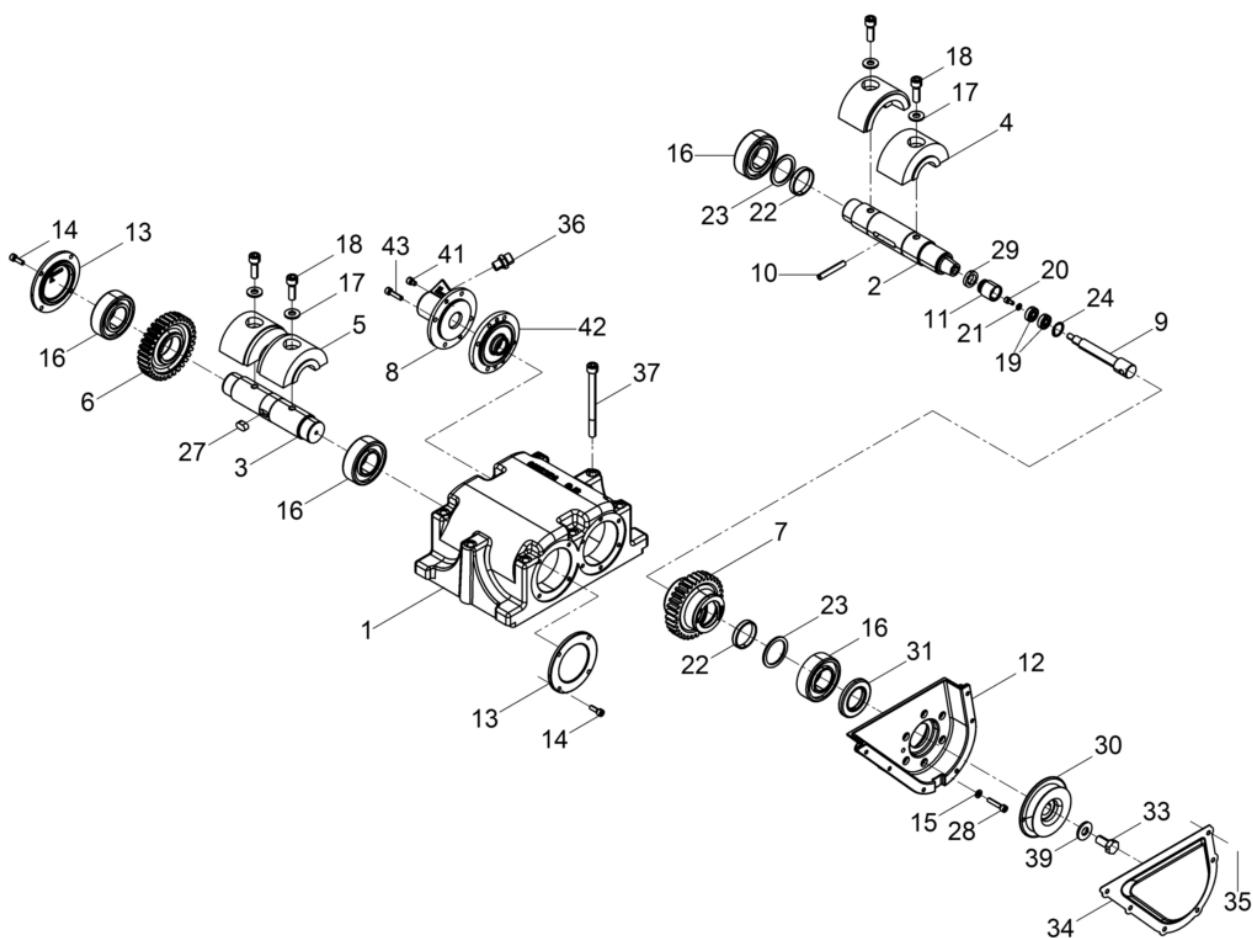

Pos. Ref.	Artikel Nr. Part No.	Qty.	Unit	Beschreibung Descripción	Description Description	Abm. Measur.	Norm Standard
						Drehm. Torque	Schmierstoff Sealant
1	5000125375	1	PC	Erregergehäuse Carcasa del excitador	Exciter housing Carter excitateur		
2	5000220064	1	PC	Welle Árbol	Shaft Arbre		
3	5000220065	1	PC	Welle Árbol	Shaft Arbre		
4	5000220067	2	PC	Unwucht Masa excéntrica	Eccentric weight Balourd		
5	5000220069	2	PC	Unwucht Masa excéntrica	Eccentric weight Balourd		
6	5000047057	1	PC	Zahnrad Engranaje	Gear wheel Roue dentée		
7	5000220056	1	PC	Verstellhülse Husillo de regulación	Adjusting sleeve Douille de réglage		
8	5000220220	1	PC	Zylinderdeckel Tapa del cilindro	Cylinder cover Couvercle de cylindre		
9	5000220071	1	PC	Schaltbolzen Perno fijador	Indexing bolt Boulon		
10	5000220073	1	PC	Schaltstift Espiga de mando	Tripping pin Broche de manoeuvre		
11	5000220355	1	PC	Kolben Pistón	Piston Piston		
12	5000126159	1	PC	Riemenschutz Protección de la polea	Belt guard Protection de courroie		
13	5000126166	2	PC	Deckel Tapa	Cover Couvercle		
14	5000011552	8	PC	Zylinderschraube Tornillo cilíndrico	Cheese head screw Vis à tête cylindrique	M6 x 18 10Nm/7ft.lbs	ISO4762
15	5000010624	6	PC	Scheibe Arandela	Flat washer Rondelle		
16	5000105139	4	PC	Zylinderrollenlager Rodamiento cilíndricos	Cylindrical roller bearing Roulement à rouleaux		
17	5000033988	4	PC	Spannscheibe Arandela elástica	Lockwasher Rondelle de ressort	10	DIN6796
18	5000220074	4	PC	Zylinderschraube Tornillo cilíndrico	Cheese head screw Vis à tête cylindrique	M10x 30	DIN912
19	5002006596	2	PC	Rillenkugellager Rodamiento a bolas	Grooved ball bearing Roulement rainuré à billes		
20	5000024617	1	PC	Zylinderschraube Tornillo cilíndrico	Cheese head screw Vis à tête cylindrique	M5 x 10 10Nm/7ft.lbs	ISO4762
21	5000010625	1	PC	Scheibe Arandela	Washer Rondelle		
22	5000220072	2	PC	Buchse Buje	Bushing Douille		
23	5000220075	2	PC	Stützscheibe Arandela de soporte	Supporting washer Disque d'appui	S40x50	DIN988
24	5002004979	1	PC	Sicherungsring Anillo de retención	Retaining ring Bague d'arrêt	22 x 1	DIN472
27	5000014844	1	PC	Passfeder Chaveta	Fitting key Clavette	A10 x 8 x 18	DIN6885
28	5000011549	6	PC	Zylinderschraube Tornillo cilíndrico	Cheese head screw Vis à tête cylindrique	M6 x 30 10Nm/7ft.lbs	ISO4762
29	5000220356	1	PC	Gummilippenring Reten labial de goma	Lip seal ring Bague en caoutchouc	25x 17x 5,5	
30	5000125371	1	PC	Keilriemenscheibe Polea en v	V-belt pulley Poulie à courroie		

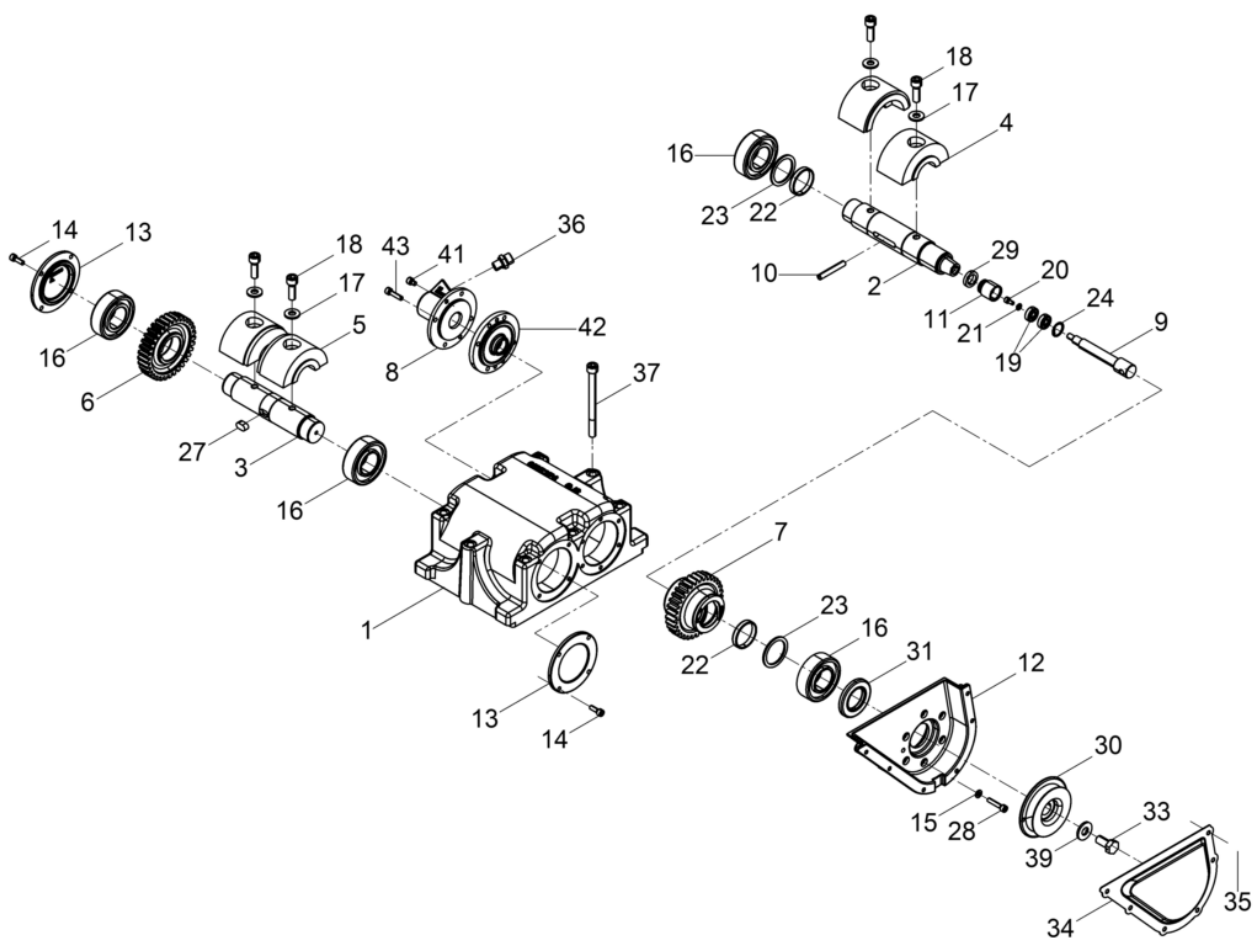

Pos. Ref.	Artikel Nr. Part No.	Qty.	Unit	Beschreibung Descripcion	Description Description	Abm. Measur.	Norm Standard
						Drehm. Torque	Schmierstoff Sealant
31	5000126167	1	PC	Wellendichtring Anillo de retén radial	Rotary shaft seal Bague d'étanchéité		
33	5000126179	1	PC	Entlüftungsschraube Tornillo de purga	Vent screw Vis d'évacuation d'air		
34	5000125360	1	PC	Deckel Tapa	Cover Couvercle		
35	5100009501	6	PC	Kombi-schraube Tornillo	Screw Vis	M6 x 16 10Nm/7ft.lbs	
36	5000046461	1	PC	Einschraubstutzen Empalme roscado	Screwed socket Manchon visse		DIN3901
37	5000094073	8	PC	Zylinderschraube Tornillo cilíndrico	Cheese head screw Vis à tête cylindrique	M10 x 120 69Nm/51ft.lbs	ISO4762
39	5000031565	1	PC	Spannscheibe Arandela elástica	Lockwasher Rondelle de ressort	12	DIN6796
41	5000014425	2	PC	Zylinderschraube Tornillo cilíndrico	Cheese head screw Vis à tête cylindrique	10Nm/7ft.lbs	
42	5000220216	1	PC	Anschlagdeckel Tapa	Cover Couvercle		
43	5000011550	4	PC	Zylinderschraube Tornillo cilíndrico	Cheese head screw Vis à tête cylindrique	M6 x 25 10Nm/7ft.lbs	ISO4762

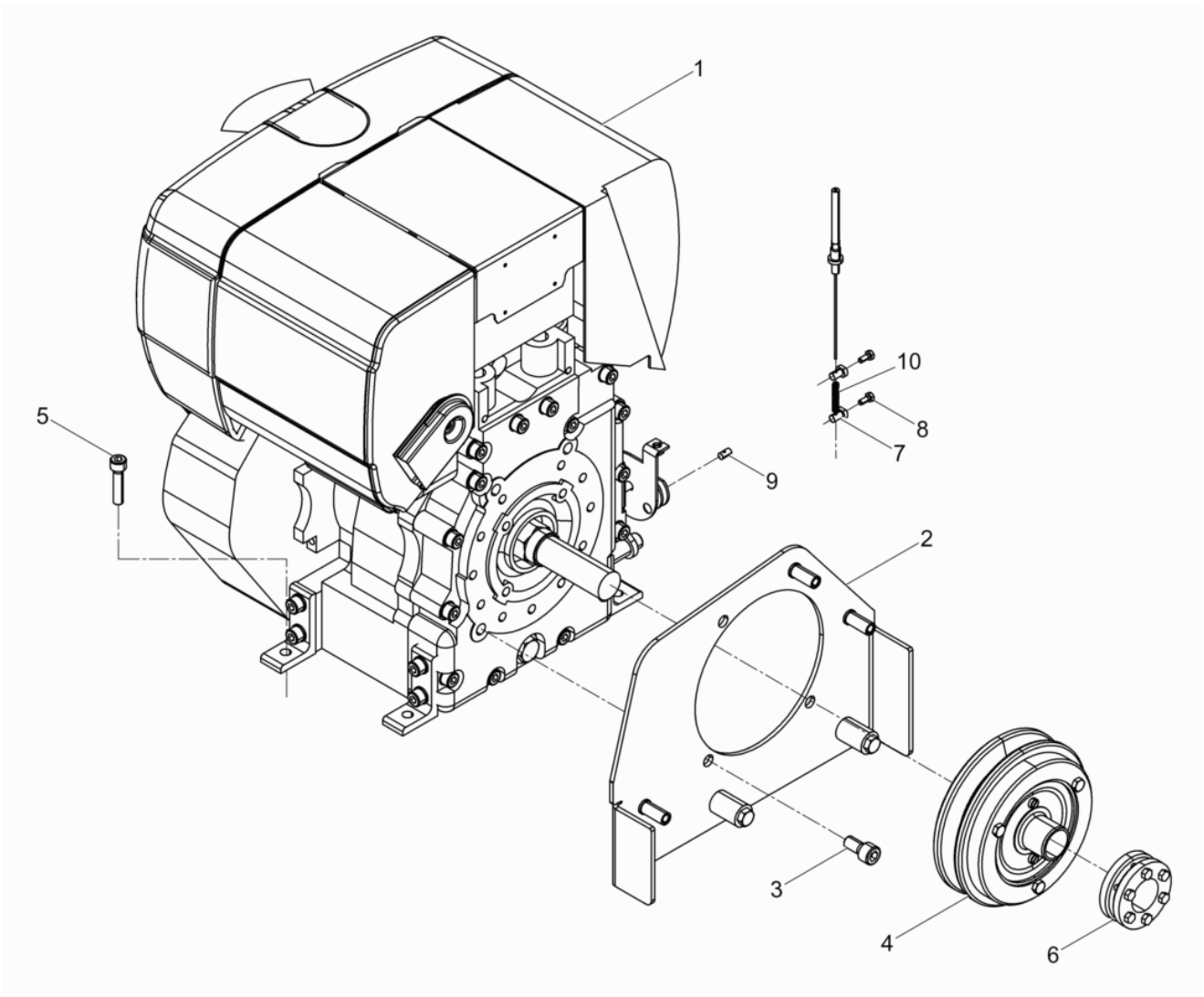

Pos. Ref.	Artikel Nr. Part No.	Qty.	Unit	Beschreibung Descripcion	Description Description	Abm. Measuram.	Norm Standard
						Drehm. Torque	Schmierstoff Sealant
1	5100043172	1	PC	Dieselmotor Motor diesel	Diesel engine Moteur diesel		
2	5000216674	1	PC	Befestigungsblech kpl. Chapa de sujeción cpl.	Fixing plate cpl. Tôle de fixation cpl.		
3	5000011536	3	PC	Zylinderschraube Tornillo cilíndrico	Cheese head screw Vis à tête cylindrique	M10 x 20 49Nm/36ft.lbs	ISO4762
4	5000126185	1	PC	Fliehkraftkupplung Embrague	Centrifugal clutch Embrayage		
5	5000011540	4	PC	Zylinderschraube Tornillo cilíndrico	Cheese head screw Vis à tête cylindrique	M8 x 35 25Nm/18ft.lbs	ISO4762
6	5000108633	1	PC	Spannelement Elemento de sujeción cónico	Tightening element Garniture de serrage		
7	5000212532	2	PC	Schraubnippel Boquilla roscada	Screw nipple Raccord de vissage		
8	5000124429	2	PC	Sechskantschraube Tornillo hexagonal	Hexagonal head cap screw Vis à tête hexagonale	M4 x 10	DIN933
9	5000212531	1	PC	Schraubnippel Boquilla roscada	Screw nipple Raccord de vissage		
10	5000212534	1	PC	Druckfeder Resorte de compresión	Compression spring Ressort de pression	1 x 4 x 33 x 19,5	

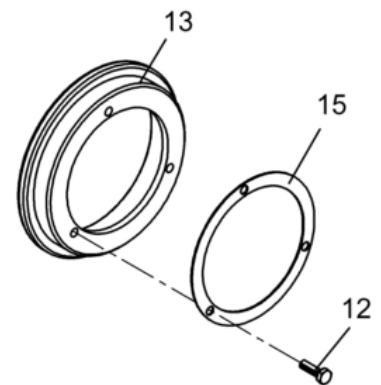
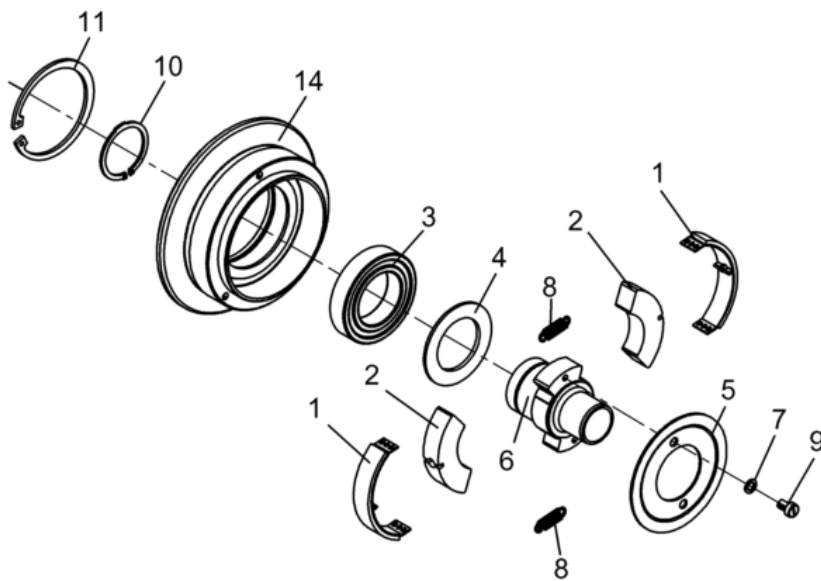

Pos. Ref.	Artikel Nr. Part No.	Qty.	Unit	Beschreibung Descripción	Description Description	Abm. Measur.	Norm Standard
						Drehm. Torque	Schmierstoff Sealant
1	5000022861	2	PC	Belagbügel Zapata	Lining Garniture d'embrayage		
2	5000059738	2	PC	Fliehgewicht Peso centrifugo	Centrifugal weight Poids centrifuge		
3	5000018256	1	PC	Rillenkugellager Rodamiento a bolas	Grooved ball bearing Roulement rainuré à billes		
4	5000201727	1	PC	Scheibe Arandela	Washer Rondelle		
5	5000201726	1	PC	Deckscheibe Arandela	Cover washer Rondelle de recouvrement		
6	5000203284	1	PC	Nabe Cubo	Hub Moyeu		
7	5000201719	2	PC	Sicherungsscheibe Arandela de seguridad	Lock washer Rondelle d'arrêt	S6	
8	5000201724	2	PC	Zugfeder Resorte de tracción	Tension spring Ressort de traction		
9	5000201718	2	PC	Zylinderschraube Tornillo cilíndrico	Cheese head screw Vis à tête cylindrique		
10	5000201717	1	PC	Sicherungsring Anillo de retención	Retaining ring Bague d'arrêt	A40 x 1,75	
11	5000201715	1	PC	Sicherungsring Anillo de retención	Retaining ring Bague d'arrêt	J68 x 2,5	
12	5000201713	3	PC	Sechskantschraube Tornillo hexagonal	Hexagonal head cap screw Vis à tête hexagonale	M6 x 20	
13	5000201723	1	PC	Kupplungsglocke Campana del embrague	Clutch drum Cloche de rentrée		
14	5000201722	1	PC	Kupplungsglocke Campana del embrague	Clutch drum Cloche de rentrée		
15	5000201721	2	PC	Passscheibe Arandela de ajuste	Shim ring Disque d'ajustage		

Deichsel kpl.
Center pole cpl.
Barra de mando cpl.
Timon cpl.

DPU 3750HTS

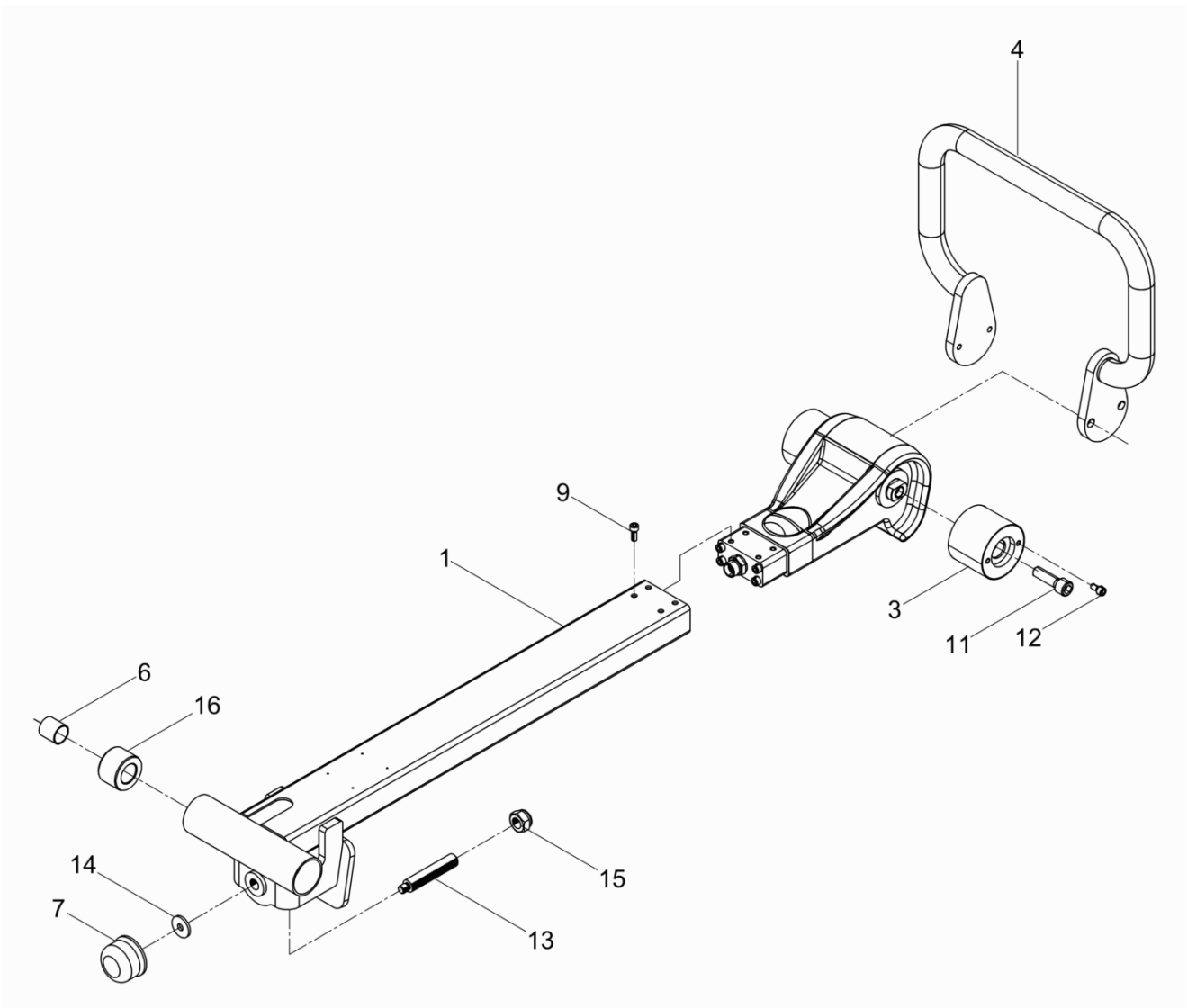

Pos. Ref.	Artikel Nr. Part No.	Qty.	Unit	Beschreibung Descripcion	Description Description	Abm. Measuram.	Norm Standard
						Drehm. Torque	Schmierstoff Sealant
1	5000126566	1	PC	Deichsel Barra de mando	Center pole Timon		
3	5000215035	2	PC	Gummi-metall-puffer Tope caucho-metal	Shockmount Tampon metallique oscillant		
4	5000214990	1	PC	Bügel Abrazadera	Clamp Attache		
6	5000126164	2	PC	Gleitbuchse Buje deslizante	Slide bush Boîte de glissement		
7	5000127085	1	PC	Anschlagpuffer Amortiguador	Shockmount Silentbloc		
9	5000011553	8	PC	Zylinderschraube Tornillo cilíndrico	Cheese head screw Vis à tête cylindrique	10Nm/7ft.lbs	
11	5000011527	2	PC	Zylinderschraube Tornillo cilíndrico	Cheese head screw Vis à tête cylindrique	86Nm/63ft.lbs	
12	5000011554	4	PC	Zylinderschraube Tornillo cilíndrico	Cheese head screw Vis à tête cylindrique	10Nm/7ft.lbs	
13	5000201009	1	PC	Gewindespindel Husillo roscado	Threaded spindle Tige fileté		
14	5000012976	1	PC	Scheibe Arandela	Washer Rondelle	R11	DIN440
15	5000013496	1	PC	Sechskantmutter Tuerca hexagonal	Hexagon nut Écrou hexagonal	M16	DIN985
16	5000201018	2	PC	Buchse Buje	Bush Boîte		

Deichselkopf kpl.
Center pole head cpl.
Cabezal de mando cpl.
Tête de timon cpl.

DPU 3750HTS

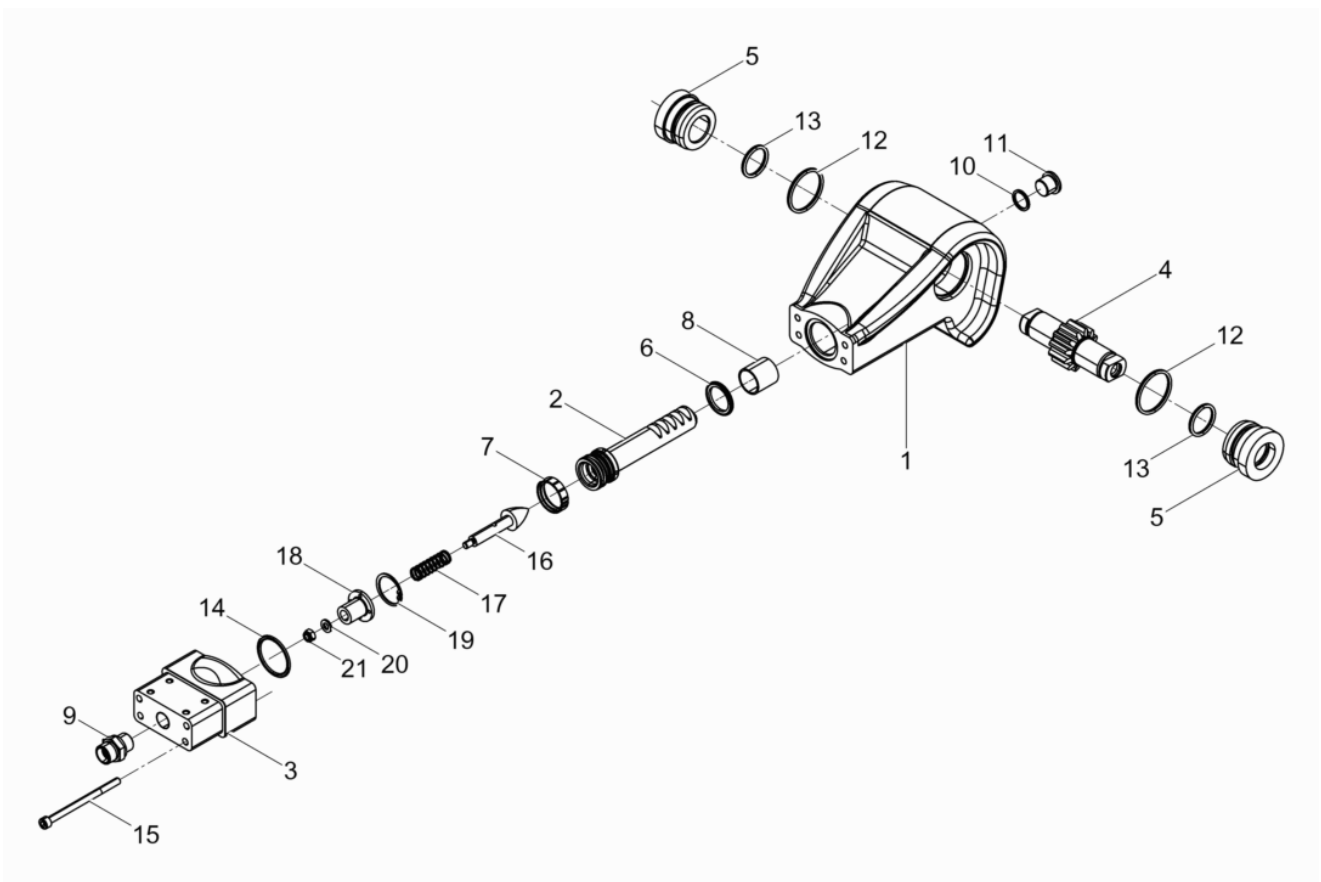

Pos. Ref.	Artikel Nr. Part No.	Qty.	Unit	Beschreibung Descripción	Description Description	Abm. Measur.	Norm Standard
						Drehm. Torque	Schmierstoff Sealant
1	5000125363	1	PC	Deichselkopf Cabezal de barra	Center pole head Tête de timon		
2	5100018558	1	PC	Kolbenstange Biela de pistón	Piston rod Tige de piston		
3	5000125924	1	PC	Adapter deichselkopf Adaptador cabezal de barra	Guide pole head adapter Adaptateur tête à timon		
4	5000069726	1	PC	Zahnradwelle Eje de rueda dentada	Long face pinion Arbre formant pignon		
5	5000125926	2	PC	Distanzstück Pieza distanciadora	Spacer Pièce d'écartement		
6	5000129269	1	PC	Kompaktdichtung Junta compacta	Compact seal Garniture compacte		
7	5000126163	1	PC	Kolbenführungsring Anillo guía de pistón	Piston guide ring Bague de guidage du piston		
8	5000126164	1	PC	Gleitbuchse Buje deslizante	Slide bush Boîte de glissement		
9	5000046092	1	PC	Einschraubstutzen Empalme roscado	Screwed socket Manchon visse		DIN3901
10	5000012082	1	PC	Dichtungsring Anillo sellador	Seal ring Rondelle à étancher	A16 x 20	DIN7603
11	5000011050	1	PC	Verschlusschraube Tapón roscado	Plug (threaded) Bouchon	M16 x 1,5	DIN908
12	5000068752	2	PC	O-ring Anillo-o	O-ring Bague-o		
13	5000018194	2	PC	O-ring Anillo-o	O-ring Bague-o		
14	5000067781	1	PC	O-ring Anillo-o	O-ring Bague-o		
15	5000200651	4	PC	Zylinderschraube Tornillo cilíndrico	Cheese head screw Vis à tête cylindrique	M6 x 90	ISO4762
16	5100018559	1	PC	Dichtkegel Cono de junta	Seal cone Bague d'icône		
17	5100018591	1	PC	Druckfeder Resorte de compresión	Compression spring Ressort de pression		
18	5100018590	1	PC	Führungshülse Casquillo de guía	Guide sleeve Douille de guidage		
19	5002001695	1	PC	Sicherungsring Anillo de retención	Retaining ring Bague d'arrêt	30 x 1,2	DIN472
20	5000010624	1	PC	Scheibe Arandela	Flat washer Rondelle		
21	5000010368	1	PC	Sechskantmutter Tuerca hexagonal	Hexagon nut Écrou hexagonal	M6	DIN985

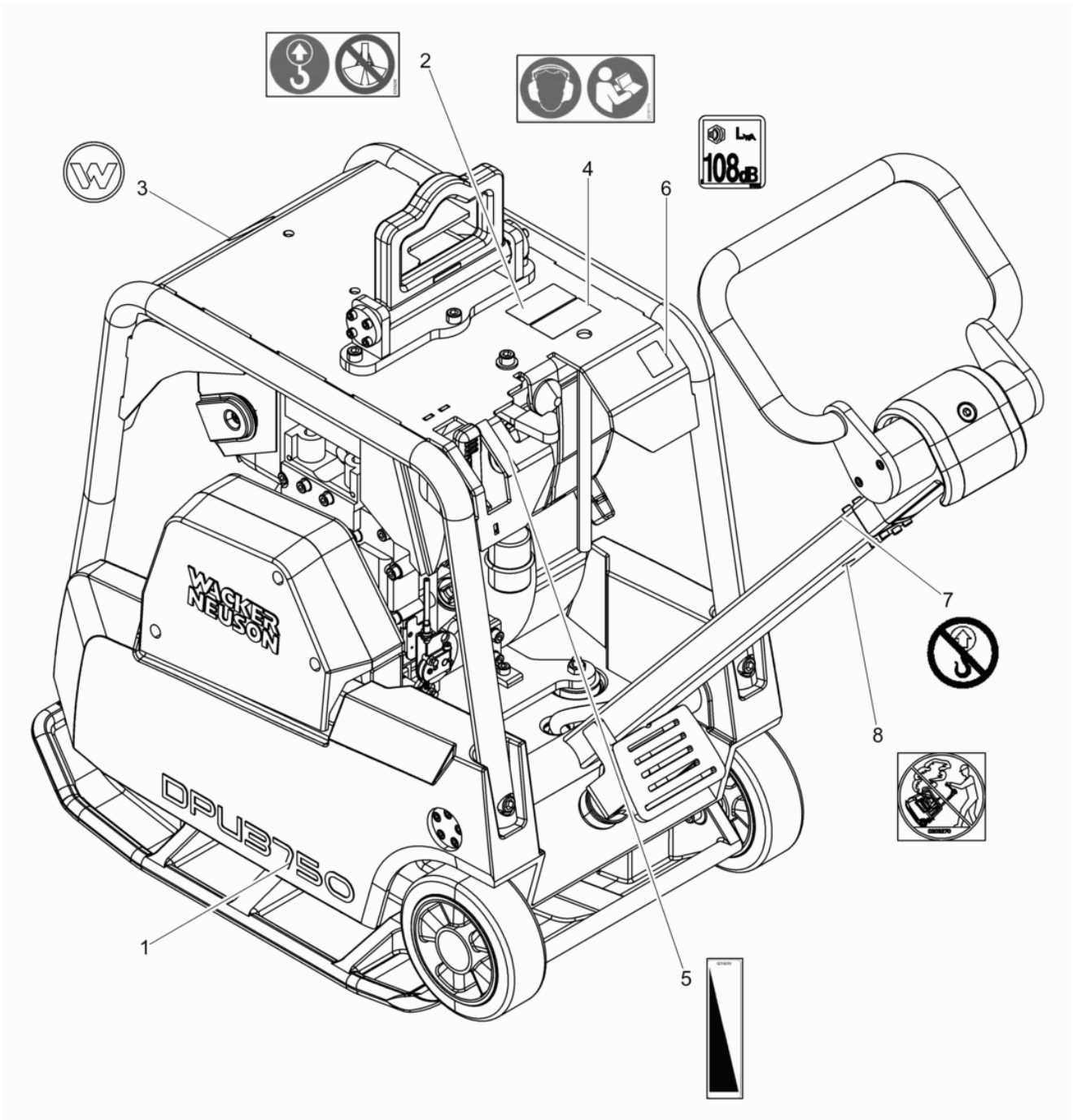

Pos. Ref.	Artikel Nr. Part No.	Qty.	Unit	Beschreibung Descripcion	Description Description	Abm. Measur.	Norm Standard
						Drehm. Torque	Schmierstoff Sealant
1	5000220096	2	PC	Aufkleber-typ Tipo etiqueta autoadhesiva	Type label Autocollant de type		
2	5000219260	1	PC	Aufkleber Calcomanias	Labels Autocollants		
3	5000222085	1	PC	Aufkleber symbol Calcomania simbolo	Label symbol Autocollant symbole		
4	5000219175	1	PC	Aufkleber Calcomanias	Labels Autocollants		
5	5000219259	1	PC	Aufkleber Calcomanias	Labels Autocollants		
6	5000129784	1	PC	Aufkleber-schalleistungspegel Etiqueta autoadhesiva-nivel de potencia acúëística	Decal-sound power level Autocollante-niveau sonore		
7	5000220000	1	PC	Aufkleber-warnhinweis Calcomanía-indicación	Instruction label Autocollant avec indication		
8	5000203270	1	PC	Warnschild Señal de aviso	Warning sign Plaque de attention		

Abschleppöse kpl.
Towing eye cpl.
Ojete de remorque cpl.
Oeillet cpl.

DPU 3750HTS

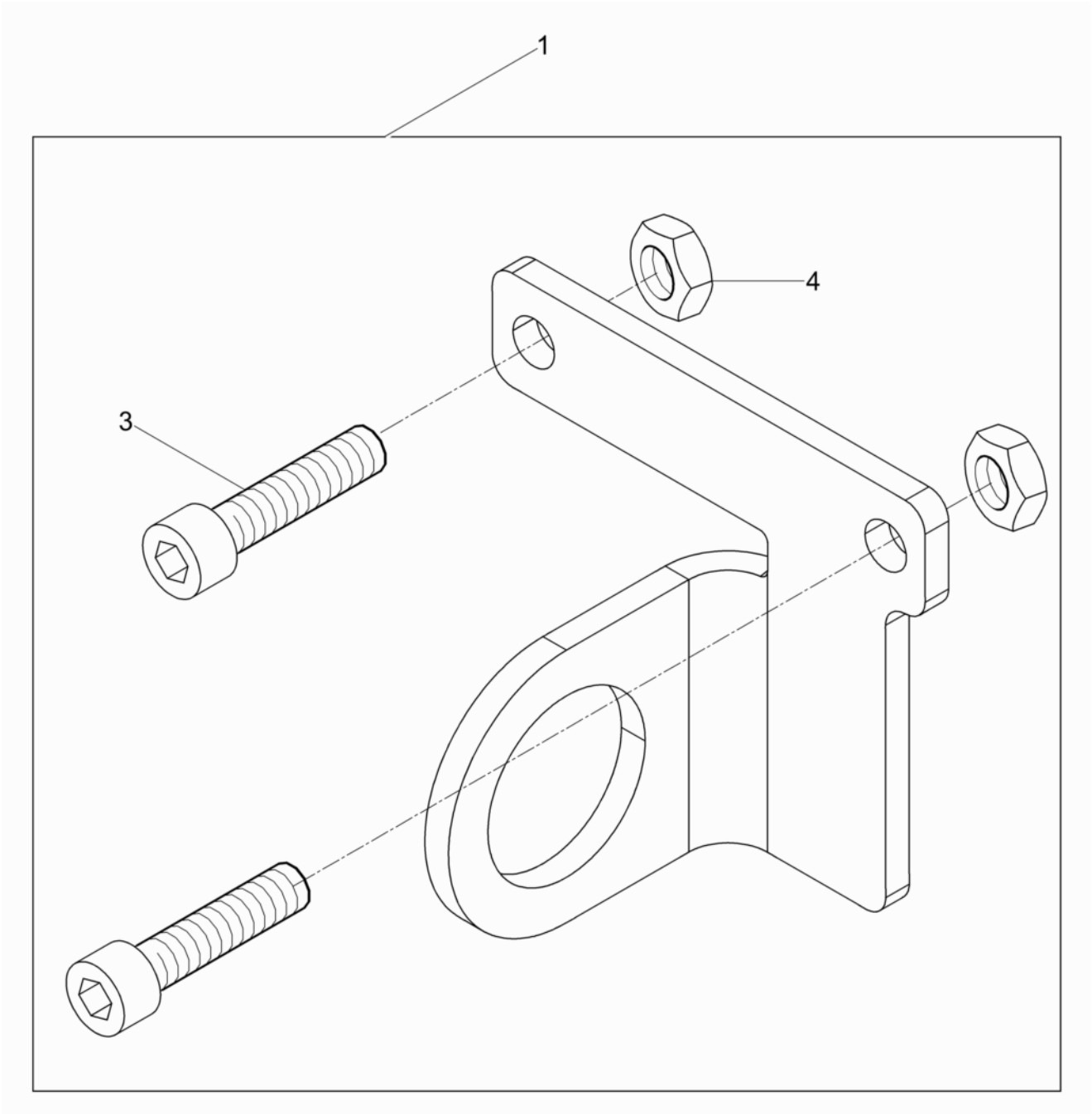

Pos. Ref.	Artikel Nr. Part No.	Qty.	Unit	Beschreibung Descripcion	Description Description	Abm. Measur.	Norm Standard
						Drehm. Torque	Schmierstoff Sealant
1	5000205381	1	PC	Abschleppöse kpl. Ojete de remolque cpl.	Towing eye cpl. Oeillet cpl.		
3	5000011540	2	PC	Zylinderschraube Tornillo cilíndrico	Cheese head screw Vis à tête cylindrique	M8 x 35 25Nm/18ft.lbs	ISO4762
4	5000010883	2	PC	Sechskantmutter Tuerca hexagonal	Hexagon nut Écrou hexagonal		

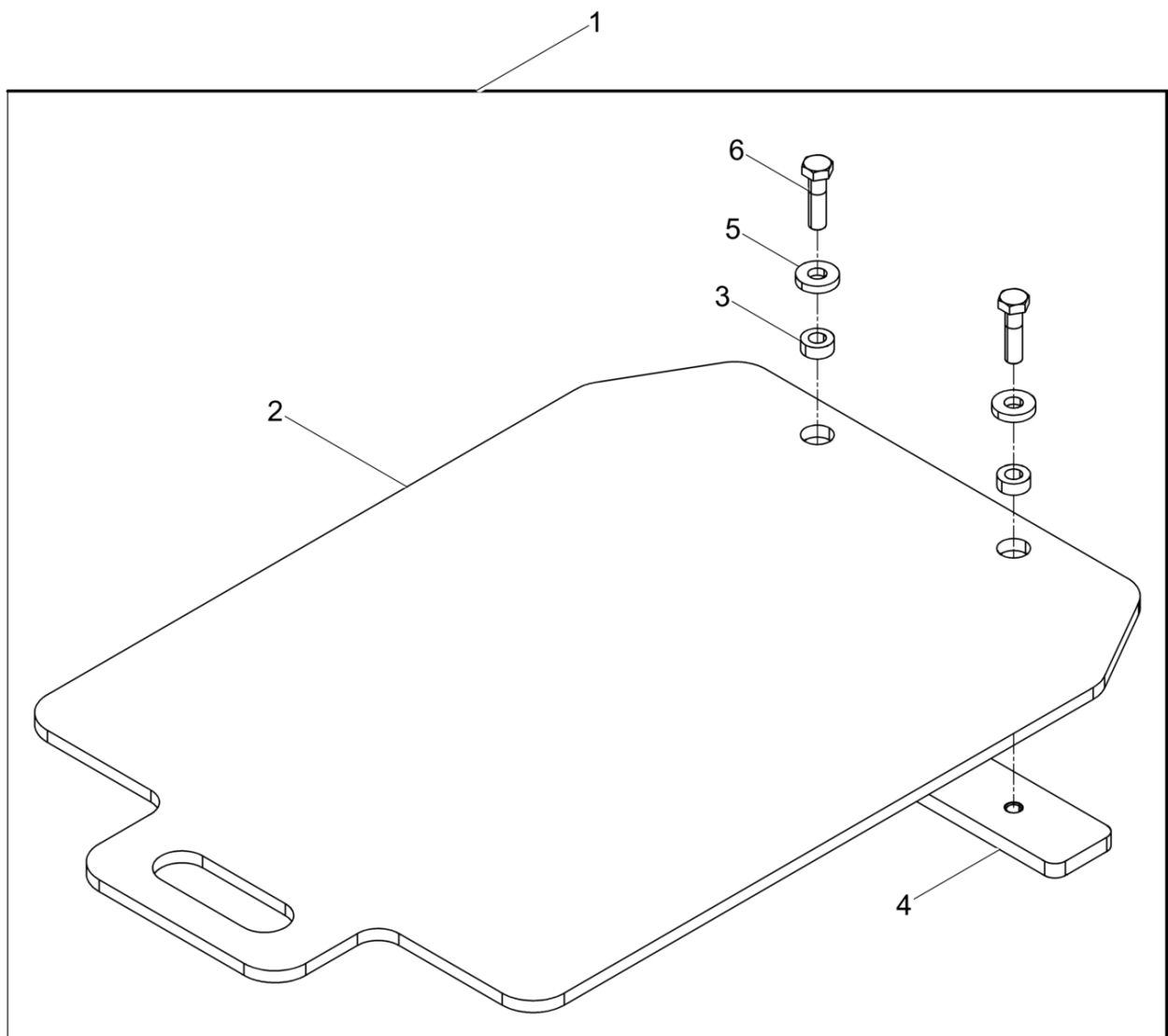

Pos. Ref.	Artikel Nr. Part No.	Qty.	Unit	Beschreibung Descripcion	Description Description	Abm. Measur.	Norm Standard
						Drehm. Torque	Schmierstoff Sealant
1	5000200572	1	PC	Pflastergleitvorrichtung Placa de deslizamiento pgv50	Urethane pad kit pgv50 Jeu de tapis en polyuréthane	50cm	
2	5000200654	1	PC	Kunststoffplatte Juego de lamina de uretano	Urethane plate Dispositif de glissement		
3	5000200569	2	PC	Buchse Buje	Bushing Douille		
4	5000200570	1	PC	Leiste Listón	Bar Listeau		
5	5000013618	2	PC	Scheibe Arandela	Flat washer Rondelle	13	DIN7349
6	5000011300	2	PC	Sechskantschraube Tornillo hexagonal	Hexagonal head cap screw Vis à tête hexagonale	M12 x 45 86Nm/63ft.lbs	ISO4014



**WACKER
NEUSON**

