



**WACKER
NEUSON**

Ersatzteilkatalog
Spare parts list
Catalogo de piezas de repuesto
Catalogue des pièces détachées

**Pumpe
Pump
Bombas
Pompes**

PS47503HF



Type	PS47503HF
Material Number	5000008863
Version	102
Language	de en es fr



www.wackerneuson.com

Copyright © 06.2019
Wacker Neuson Production Americas LLC
Printed in USA.
All rights reserved.

Ein Typenschild mit Typ, Artikelnummer, Version und Maschinen-Nummer ist an jedem Gerät angebracht. Die Daten von diesem Schild bitte notieren, damit sie auch bei Verlust oder Beschädigung des Schildes noch vorhanden sind. Der Typ, die Artikelnummer, die Versions-Nummer und die Maschinen-Nummer sind bei der Ersatzteilbestellung oder Nachfragen bezüglich Service-Informationen stets erforderlich.

Bei den in den Ersatzteillisten fettgedruckten Nummern handelt es sich um empfohlene Ersatzteile. Dies bedeutet, daß diese Teile bei normalen Anwendungsbedingungen natürlicher Abnutzung ausgesetzt sind und gelegentlich ersetzt oder überarbeitet werden müssen. Es wird geraten, diese Teile auf Lager bereit zu haben, um für Service-Arbeiten an diesem Gerät vorbereitet zu sein. Lagerbestände für diese und andere Teile, welche für ausgiebigere Reparaturarbeiten benötigt werden, können je nach Service-Gewohnheiten der einzelnen Kunden variieren.

Die Nummern meines Gerätes sind:

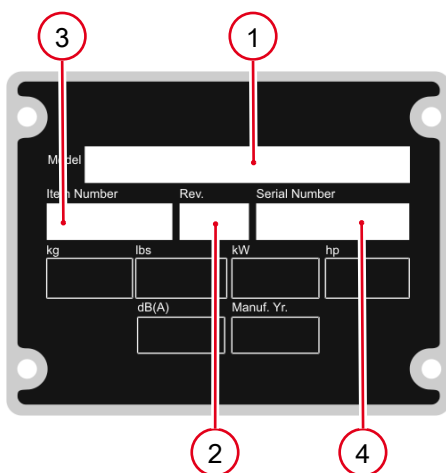

1. Typ
2. Version
3. Artikel-Nr.
4. Maschinen-Nr.

Umrechnungstabelle

Volumeneinheit	
1 ml	0.034 US fl.oz.
1 l	0.260 gal
Längeneinheit	
1 mm	0.039 in
1 m	3.280 ft
Gewicht	
1 kg	2.200 lbs
1 g	0.035 oz
Geschwindigkeit	
1 km/h	0.620 mph
Drehmoment	
1 Nm	0.740 ft.lbs

A nameplate listing the Model Number, Item Number, Revision, and Serial Number is attached to each unit. Please record the information found on this plate so it will be available should the nameplate become lost or damaged. When ordering parts or requesting service information, you will always be asked to specify the model, item number, revision number, and serial number of the unit.

Part Numbers appearing in boldface type are recommended spare parts. This means that these parts are subject to wear under normal operating conditions and may require periodic service or replacement. It is recommended that these items be stocked to meet the expected service requirements of this model. Actual stocking quantities of these and other parts used in more extensive repairs will depend on the service practices of each customer.

My machine's numbers are:

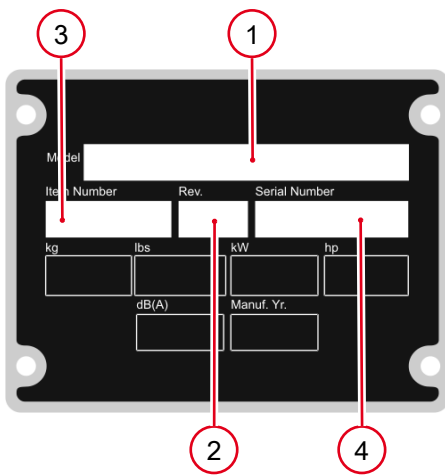

1. Model
2. Revision
3. Item No.
4. Serial No.

Conversion table

Volume unit	
1 ml	0.034 US fl.oz.
1 l	0.260 gal
Unit of length	
1 mm	0.039 in
1 m	3.280 ft
Weight	
1 kg	2.200 lbs
1 g	0.035 oz
Speed	
1 km/h	0.620 mph
Torque	
1 Nm	0.740 ft.lbs

Una placa de identificación con el modelo, número de referencia, nivel de revisión y número de serie ha sido añadida en cada máquina. Favor de anotar los datos en la placa en caso de que la placa de identificación sea destruida o perdida. En todos los pedidos para repuestos necesita siempre el modelo, el número de referencia, el nivel de revisión y el número de serie de la máquina en cuestión.

Los números de partes en negritas en las Listas Ilustradas de Partes son los repuestos recomendados, esto quiere decir que estas partes se desgastarán bajo circunstancias de funcionamiento normales y pueden requerir servicio periódico o su reemplazo. Se recomienda que el cliente mantenga un abastecimiento adecuado de estas partes para poder satisfacer la demanda requerida por el servicio a la máquina. La cantidad de repuestos que el cliente necesitará para reparaciones dependerá de la póliza de servicio de cada cliente.

Los números de mi máquina son:

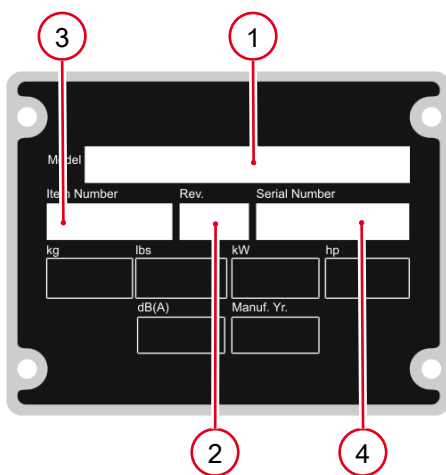

1. Modelo
2. Nivel de revisión
3. Número de referencia
4. Número de Serie

Tabla de conversión

Unidad de volumen	
1 ml	0.034 US fl.oz.
1 l	0.260 gal
Unidad de longitud	
1 mm	0.039 in
1 m	3.280 ft
Peso	
1 kg	2.200 lbs
1 g	0.035 oz
Velocidad	
1 km/h	0.620 mph
Par de apriete	
1 Nm	0.740 ft.lbs

Une plaque signalétique mentionnant le modèle, le numéro de référence, le niveau de revision et le numéro de série est fixée sur chaque machine. Veuillez noter les informations relevées sur cette plaque de façon à ce qu'elles soient toujours disponibles si la plaque signalétique venait à être perdue ou endommagée. Lorsque vous commandez des pièces détachées ou vous sollicitez des informations après-vente, on vous demandera toujours de préciser le modèle, le numéro de référence, le niveau de revision et le numéro de série de la machine.

Les numéros de pièces imprimés en caractères gras dans les Listes des Pièces Détachées de ce manuel sont les pièces détachées recommandées par la Wacker. Cela veut dire que ces pièces sont sujettes à usure dans des conditions de travail normales et peuvent nécessiter de l'entretien ou leur remplacement. Nous recommandons que vous disposiez d'un stock de ces pièces pour pouvoir satisfaire la demande d'entretien de cette machine. Le client doit décider lui-même de la quantité exacte de pièces de rechange qu'il disposera dans ses stocks.

Les numéros de ma machine sont :



- 1. Typ
- 2. Version
- 3. Artikel-Nr.
- 4. Maschinen-Nr.

Table de conversion

Unité de volume	
1 ml	0.034 US fl.oz.
1 l	0.260 gal
Unité de longueur	
1 mm	0.039 in
1 m	3.280 ft
Poids	
1 kg	2.200 lbs
1 g	0.035 oz
Vitesse	
1 km/h	0.620 mph
Couple de serrage	
1 Nm	0.740 ft.lbs

Bestandteile Der Pumpe
Pump components
Piezas de la bomba
Parties constituantes de la po 8

Sonderzubehör
Accessories
Accesorios
Accessoires 14



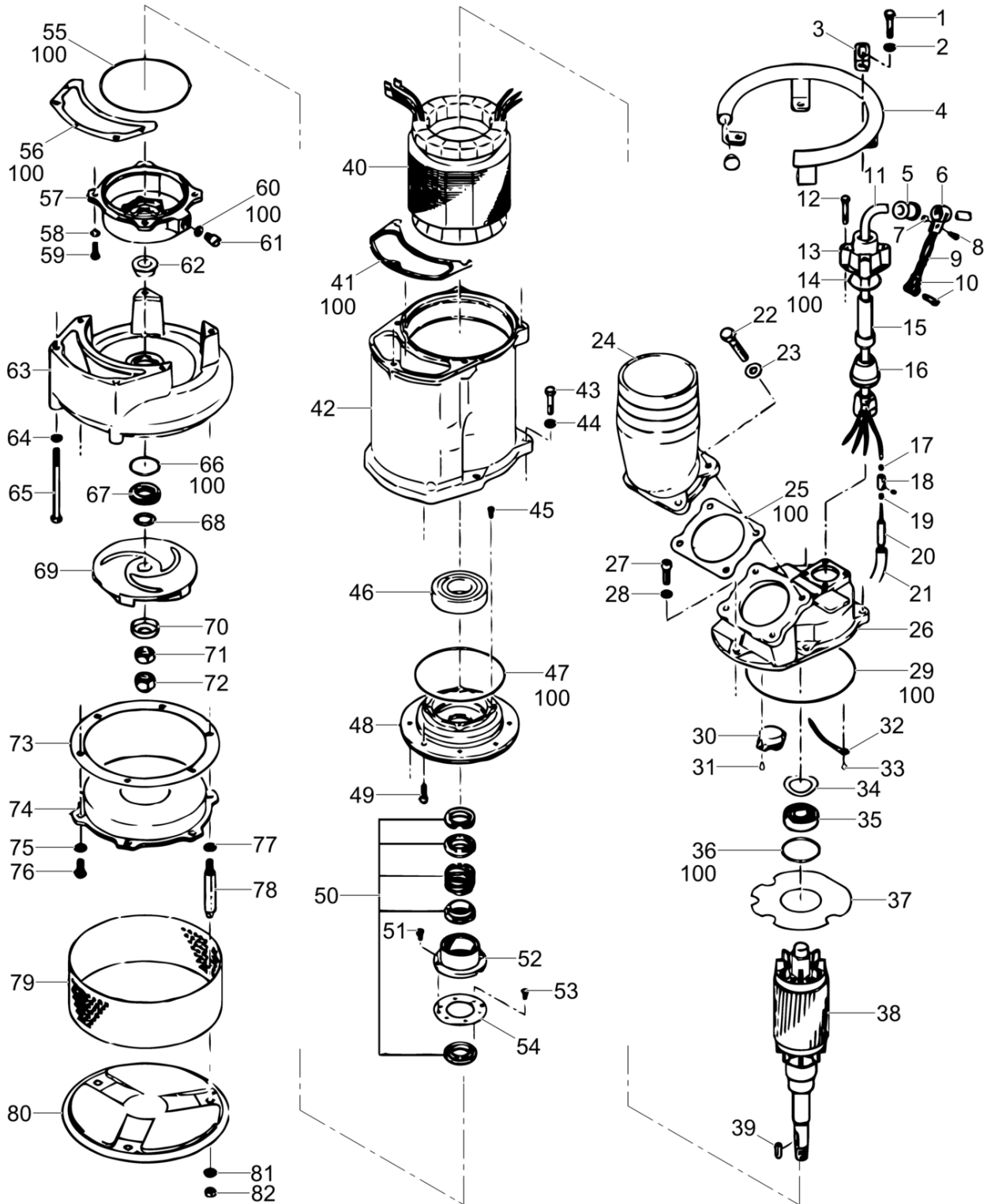

5200023474_01

Pos. Ref.	Artikel Nr. Part No.	Qty.	Unit	Beschreibung Descripcion	Description Description	Abm. Measur.	Norm Standard
						Drehm. Torque	Schmierstoff Sealant
1	5000150731	4	PC	Bolzen Perno	Bolt Boulon	M10 x 45	
2	5000150764	4	PC	Federring Federring	Lock washer Rondelle de ressort	M10	
3	5000150645	1	PC	Konsole Soporte	Bracket Support		
4	5100029772	1	PC	Tragegriff Manija de levante	Lifting handle Poignée de relèvement		
5	5000150451	1	PC	Hülse Manguito	Sleeve Douille		
6	5000150450	1	PC	Befestigung Clip	Clip Clip		
7	5100028407	1	PC	Mutter Tuerca	Nut Écrou	M6	
8	5000150715	1	PC	Bolzen Perno	Bolt Boulon	M6 x 15	
9	5000150665	1	PC	Kette Cadena	Chain Chaîne		
10	5100028548	1	PC	Haken Gancho	Hook Croc		
11	5100029775	1	PC	Konsole Soporte	Housing Support		
12	5000159722	4	PC	Schraube Mit Sicherungsmutter Tornillo con contratuerca	Screw w/locknut Vis avec contre-écrou		
13	5000150423	1	PC	Umhüllung Envoltura	Casing Gaine		
14	5000150692	1	PC	O-Ring Anillo-o	O-ring Joint torique		
15	5100029845	1	PC	Buchse Buje	Bushing Douille		
16	5000150427	1	PC	Deckel Tapa	Cover Couvercle		
17	5000150820	4	PC	Winkelstecker Terminal	Terminal post Borne d'attache		
18	5000150428	4	PC	Stoßklemme Terminal de unión	Splice terminal Borne de jointure		
19	5000150820	4	PC	Winkelstecker Terminal	Terminal post Borne d'attache		
20	5000150416	1	PC	Schrumpfschlauch Tubo de contracción	Heat shrink tube Tube rétréci		
21	5000150415	1	PC	Schrumpfschlauch Tubo de contracción	Heat shrink tube Tube rétréci		
22	5200023039	4	PC	Bolzen Perno	Bolt Boulon	M10 x 35	
23	5100028656	4	PC	Scheibe Arandela	Washer Rondelle	M10	
24	5200023045	1	PC	Schlauchkupplung Mit Stecknippel Acoplamiento de mangueras con púas	Barbed hose coupling Accouplement de tuyau avec rac	4in	
25	5200023049	1	PC	Dichtung Junta	Gasket Joint		
26	5100029775	1	PC	Konsole Soporte	Housing Support		
27	5000150737	1	PC	Bolzen Perno	Bolt Boulon		
28	5000150764	1	PC	Federring Federring	Lock washer Rondelle de ressort	M10	

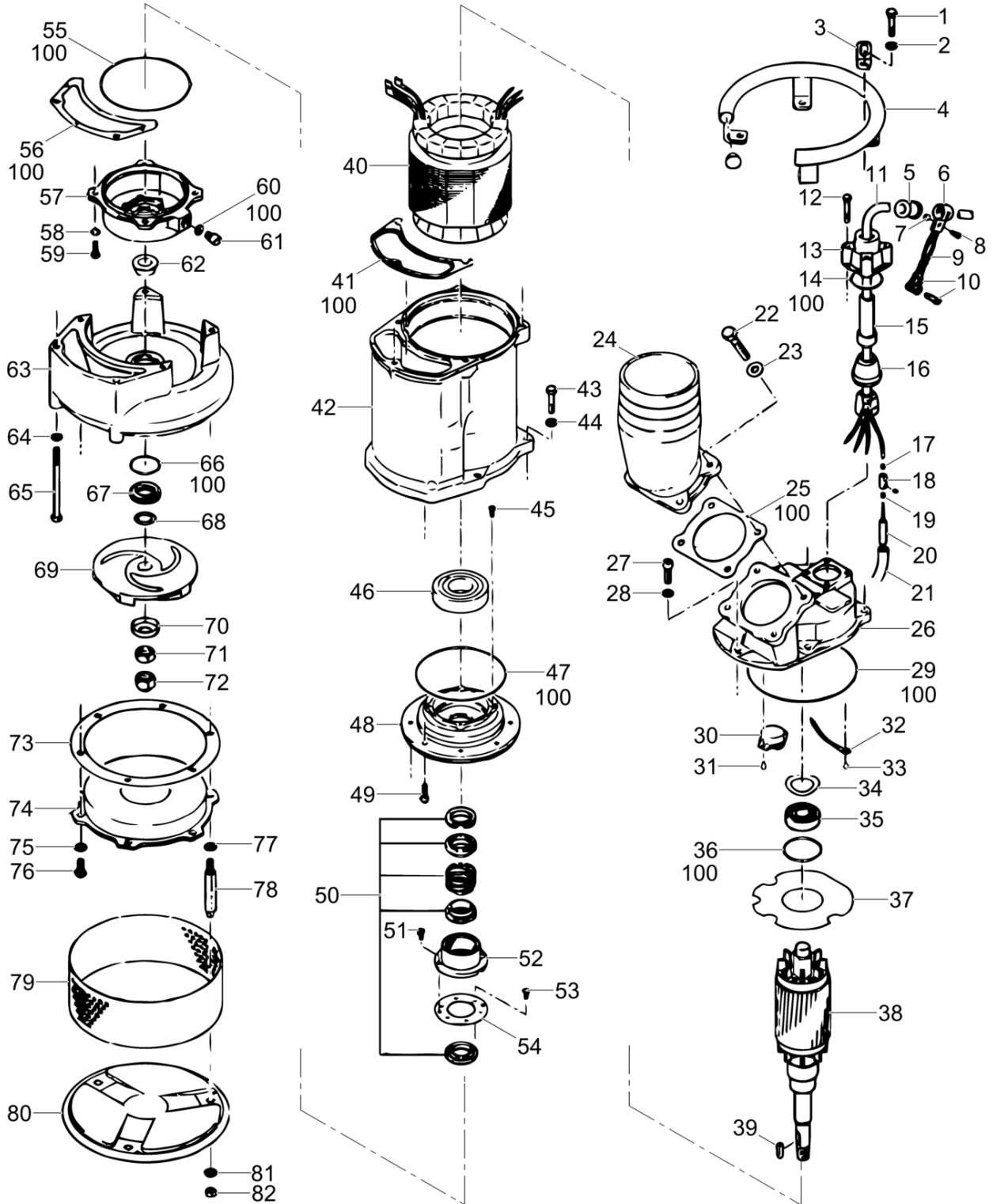

5200023474_01

Pos. Ref.	Artikel Nr. Part No.	Qty.	Unit	Beschreibung Description	Description Description	Abm. Measur.	Norm Standard
						Drehm. Torque	Schmierstoff Sealant
29	5200023061	1	PC	O-Ring Anillo-o	O-ring Joint torique		
30	5200023092	1	PC	Thermoschalter Interruptor térmico	Thermal switch Thermorupteur		
31	5000150783	2	PC	Schraube Tornillo	Screw Vis	M4 x 12	
32	5000152321	1	PC	Erdungsdraht Alambre a tierra	Ground wire Fil de masse		
33	5000177004	1	PC	Schraube Tornillo	Screw Vis	M4 x 6	
34	5000150769	1	PC	Tellerfeder Arandela de resorte	Spring washer Ressort belleville		
35	5000150559	1	PC	Kugellager Rodamiento de bolas	Ball bearing Roulement à billes		
36	5000150699	1	PC	O-Ring Anillo-o	O-ring Joint torique		
37	5100028481	1	PC	Schutzplatte Placa de protección	Protection plate Plaque de protection		
38	5200023094	1	PC	Rotor Rotor	Rotor Rotor		
39	5000150802	1	PC	Passfeder Llave	Key Clé		
40	5200023097	1	PC	Stator Estator	Stator Stator	380/400/415V 50HZ	
41	5200023080	1	PC	Dichtung Junta	Gasket Joint		
42	5100029776	1	PC	Motorgehäuse Caja del motor	Motor housing Cage du moteur		
43	5000150731	4	PC	Bolzen Perno	Bolt Boulon	M10 x 45	
44	5000150764	4	PC	Federring Federring	Lock washer Rondelle de ressort	M10	
45	5200023188	4	PC	Bolzen Perno	Bolt Boulon	M6 x 12	
46	5100028519	1	PC	Kugellager Rodamiento de bolas	Ball bearing Roulement à billes		
47	5000150703	1	PC	O-Ring Anillo-o	O-ring Joint torique		
48	5200023103	1	PC	Lagergehäuse Caja del rodamiento	Bearing housing Logement du roulement		
49	5000150735	4	PC	Schraube Tornillo	Screw Vis		
50	5100028520	1	PC	Gleitringsdichtung Sello mecánico	Mechanical seal Garniture mécanique		
51	5000150775	2	PC	Schraube Tornillo	Screw Vis		
52	5000176979	1	PC	Steigrohr Tubo alzador	Oil lifter Tuyau de refoulement		
53	5100028211	6	PC	Schraube Tornillo	Screw Vis	M5 x 6	
54	5000150519	1	PC	Lagerplatte Placa de retención	Retaining plate Plaque d'arrêt		
55	5000150703	1	PC	O-Ring Anillo-o	O-ring Joint torique		
56	5000150687	1	PC	Dichtung Junta	Gasket Joint		

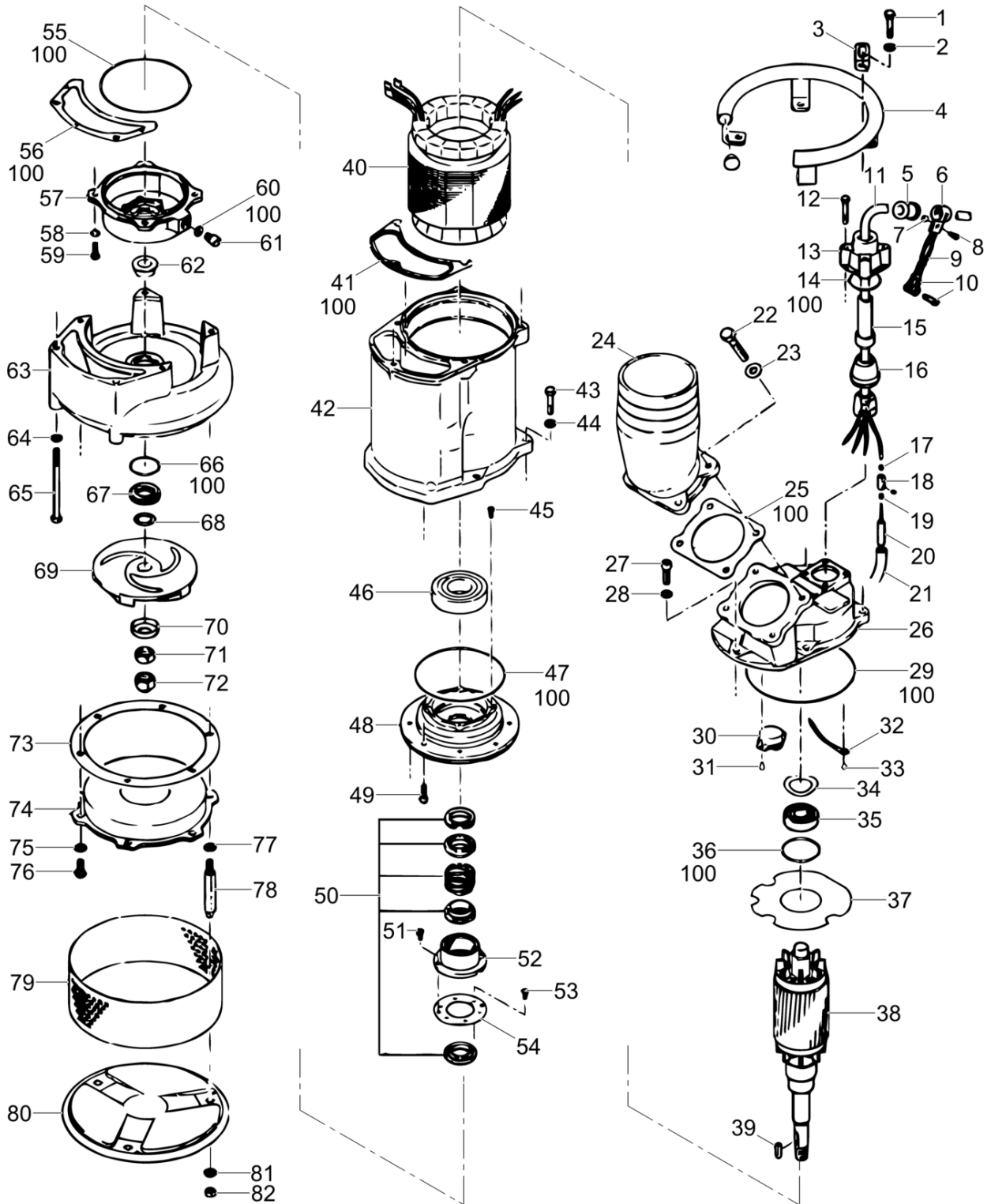

5200023474_01

Pos. Ref.	Artikel Nr. Part No.	Qty.	Unit	Beschreibung Descripcion	Description Description	Abm. Measur.	Norm Standard
						Drehm. Torque	Schmierstoff Sealant
57	5000150512	1	PC	Gehäuse Caja	Housing Carter		
58	5000150763	4	PC	Federring Federring	Lock washer Rondelle de ressort	M8	
59	5000150719	4	PC	Bolzen Perno	Bolt Boulon	M8 x 25	
60	5000150885	1	PC	Schraubverschluß Tapón roscado	Oil plug Bouchon		
61	5000150677	1	PC	Dichtung Junta	Gasket Joint		
62	5000150648	1	PC	Hülse Manguito	Sleeve Douille		
63	5200023106	1	PC	Spiralgehäuse Voluta	Volute Volute		
64	5000150764	2	PC	Federring Federring	Lock washer Rondelle de ressort	M10	
65	5000150742	2	PC	Bolzen Perno	Bolt Boulon	M10 x 150	
66	5000150705	1	PC	O-Ring Anillo-o	O-ring Joint torique		
67	5000150511	1	PC	Wellendichtring Anillo de sellado	Sealing ring Anneau d'étanchéité		
68	5000150540	1	PC	Ausgleichscheibe Laminita	Shim Cale		
69	5000152323	1	PC	Pumpenlaufrad Impulsor	Impeller Rotor avec aubes		
70	5000150542	1	PC	Deckel Tapa	Cover Couvercle		
71	5000150749	1	PC	Mutter Tuerca	Nut Écrou	M20	
72	5000150756	1	PC	Hutmutter Tuerca	Acorn nut Ecrou	M20	
73	5000150669	1	PC	Dichtung Junta	Gasket Joint		
74	5000150492	1	PC	Deckel Tapa	Cover Couvercle		
75	5000150761	3	PC	Scheibe Arandela	Washer Rondelle	M10	
76	5000150727	3	PC	Bolzen Perno	Bolt Boulon	M10 x 25	
77	5000150761	3	PC	Scheibe Arandela	Washer Rondelle	M10	
78	5000150786	3	PC	Gewindebolzen Perno prisionero	Stud bolt Boulon		
79	5000150494	1	PC	Sieb Tamizador	Strainer Tamis		
80	5000150545	1	PC	Platte Placa	Plate Plaque		
81	5000150761	3	PC	Scheibe Arandela	Washer Rondelle	M10	
82	5000150747	3	PC	Mutter Tuerca	Nut Écrou	M10	
100	5100028521	1	PC	Dichtungs- U. O-Ringsatz Juego de juntas/anillos-o	Gasket & o-ring set Jeu de joints		



1

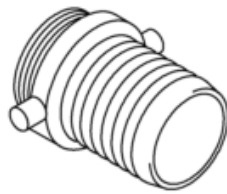

2

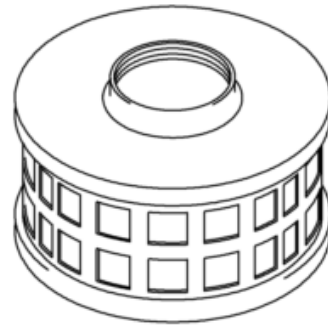

3



4

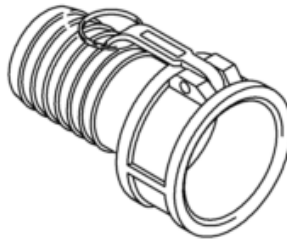

5

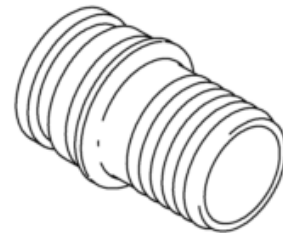

6

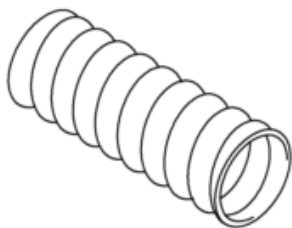

7

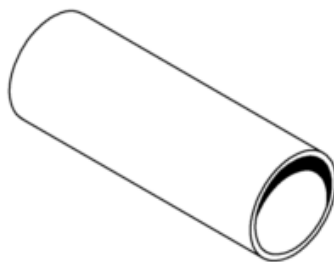

8

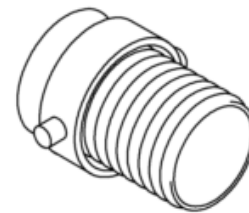

9

wc_gr001134

Pos. Ref.	Artikel Nr. Part No.	Qty.	Unit	Beschreibung Description	Description Description	Abm. Measur.	Norm Standard
						Drehm. Torque	Schmierstoff Sealant
1	5002005959	1	PC	Schlauchschelle Abrazadera	Clamp Agrafe	4-1/2in	
2	5000028074	1	PC	Schlauchstutzen Acoplamiento	Coupling Accouplement	101mm/4in	
4	5000051451	1	PC	Kupplung Acoplamiento rápido	Quick disconnect coupling Raccord express	101mm/4in	
5	5000051454	1	PC	Kupplung Acoplamiento	Coupling Accouplement	101mm/4in	
6	5000070341	1	PC	Schnellverschluß Acoplamiento rápido	Quick disconnect coupling Raccord express	101mm/4in	
7	5000028070	1	PC	PVC-Spiralsaugschlauch Manguera de succión	Suction hose Tuyau de succion	4 x 240in	
8	5000028069	1	M	Druckschlauch Manguera de descarga	Discharge hose Tuyau d'écoulement	4in	
9	5000028075	1	PC	Kupplung Acoplamiento	Coupling Accouplement	101mm/4in	
10	5000053389	1	PC	Dichtung Junta	Gasket Joint		
11	5000028076	1	PC	Dichtung Junta	Gasket Joint		
12	5000054345	1	PC	Schnellverschluß Acoplamiento rápido	Quick disconnect coupling Raccord express	110	
13	5000059980	1	PC	Dichtung Junta	Gasket Joint	110	
14	5000151080	1	PC	Abzieher Extractor	Puller Appareil de traction		



**WACKER
NEUSON**

