



**WACKER
NEUSON**

**Ersatzteilkatalog
Spare parts list
Catalogo de piezas de repuesto
Catalogue des pièces détachées**

**Pumpe
Pump
Bombas
Pompes**

PS43703

Type	PS43703
Material Number	5000008839
Version	103
Language	de en es fr



www.wackerneuson.com

Copyright © 06.2019
Wacker Neuson Production Americas LLC
Printed in USA.
All rights reserved.

Ein Typenschild mit Typ, Artikelnummer, Version und Maschinen-Nummer ist an jedem Gerät angebracht. Die Daten von diesem Schild bitte notieren, damit sie auch bei Verlust oder Beschädigung des Schildes noch vorhanden sind. Der Typ, die Artikelnummer, die Versions-Nummer und die Maschinen-Nummer sind bei der Ersatzteilbestellung oder Nachfragen bezüglich Service-Informationen stets erforderlich.

Bei den in den Ersatzteillisten fettgedruckten Nummern handelt es sich um empfohlene Ersatzteile. Dies bedeutet, daß diese Teile bei normalen Anwendungsbedingungen natürlicher Abnutzung ausgesetzt sind und gelegentlich ersetzt oder überarbeitet werden müssen. Es wird geraten, diese Teile auf Lager bereit zu haben, um für Service-Arbeiten an diesem Gerät vorbereitet zu sein. Lagerbestände für diese und andere Teile, welche für ausgiebigere Reparaturarbeiten benötigt werden, können je nach Service-Gewohnheiten der einzelnen Kunden variieren.

Die Nummern meines Gerätes sind:

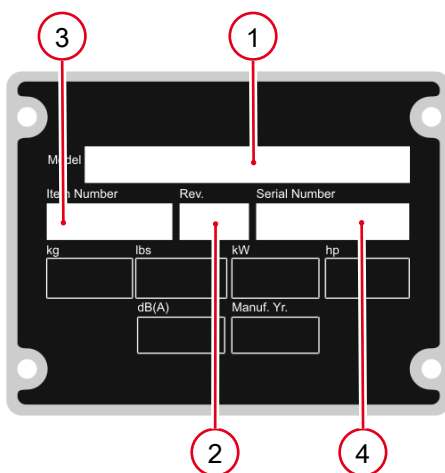

1. Typ
2. Version
3. Artikel-Nr.
4. Maschinen-Nr.

Umrechnungstabelle

Volumeneinheit	
1 ml	0.034 US fl.oz.
1 l	0.260 gal
Längeneinheit	
1 mm	0.039 in
1 m	3.280 ft
Gewicht	
1 kg	2.200 lbs
1 g	0.035 oz
Geschwindigkeit	
1 km/h	0.620 mph
Drehmoment	
1 Nm	0.740 ft.lbs

A nameplate listing the Model Number, Item Number, Revision, and Serial Number is attached to each unit. Please record the information found on this plate so it will be available should the nameplate become lost or damaged. When ordering parts or requesting service information, you will always be asked to specify the model, item number, revision number, and serial number of the unit.

Part Numbers appearing in boldface type are recommended spare parts. This means that these parts are subject to wear under normal operating conditions and may require periodic service or replacement. It is recommended that these items be stocked to meet the expected service requirements of this model. Actual stocking quantities of these and other parts used in more extensive repairs will depend on the service practices of each customer.

My machine's numbers are:



1. Model
2. Revision
3. Item No.
4. Serial No.

Conversion table

Volume unit	
1 ml	0.034 US fl.oz.
1 l	0.260 gal
Unit of length	
1 mm	0.039 in
1 m	3.280 ft
Weight	
1 kg	2.200 lbs
1 g	0.035 oz
Speed	
1 km/h	0.620 mph
Torque	
1 Nm	0.740 ft.lbs

Una placa de identificación con el modelo, número de referencia, nivel de revisión y número de serie ha sido añadida en cada máquina. Favor de anotar los datos en la placa en caso de que la placa de identificación sea destruida o perdida. En todos los pedidos para repuestos necesita siempre el modelo, el número de referencia, el nivel de revisión y el número de serie de la máquina en cuestión.

Los números de partes en negritas en las Listas Ilustradas de Partes son los repuestos recomendados, esto quiere decir que estas partes se desgastarán bajo circunstancias de funcionamiento normales y pueden requerir servicio periódico o su reemplazo. Se recomienda que el cliente mantenga un abastecimiento adecuado de estas partes para poder satisfacer la demanda requerida por el servicio a la máquina. La cantidad de repuestos que el cliente necesitará para reparaciones dependerá de la póliza de servicio de cada cliente.

Los números de mi máquina son:



1. Modelo
2. Nivel de revisión
3. Número de referencia
4. Número de Serie

Tabla de conversión

Unidad de volumen	
1 ml	0.034 US fl.oz.
1 l	0.260 gal
Unidad de longitud	
1 mm	0.039 in
1 m	3.280 ft
Peso	
1 kg	2.200 lbs
1 g	0.035 oz
Velocidad	
1 km/h	0.620 mph
Par de apriete	
1 Nm	0.740 ft.lbs

Une plaque signalétique mentionnant le modèle, le numéro de référence, le niveau de revision et le numéro de série est fixée sur chaque machine. Veuillez noter les informations relevées sur cette plaque de façon à ce qu'elles soient toujours disponibles si la plaque signalétique venait à être perdue ou endommagée. Lorsque vous commandez des pièces détachées ou vous sollicitez des informations après-vente, on vous demandera toujours de préciser le modèle, le numéro de référence, le niveau de revision et le numéro de série de la machine.

Les numéros de pièces imprimés en caractères gras dans les Listes des Pièces Détachées de ce manuel sont les pièces détachées recommandées par la Wacker. Cela veut dire que ces pièces sont sujettes à usure dans des conditions de travail normales et peuvent nécessiter de l'entretien ou leur remplacement. Nous recommandons que vous disposez d'un stock de ces pièces pour pouvoir satisfaire la demande d'entretien de cette machine. Le client doit décider lui-même de la quantité exacte de pièces de rechange qu'il disposera dans ses stocks.

Les numéros de ma machine son :

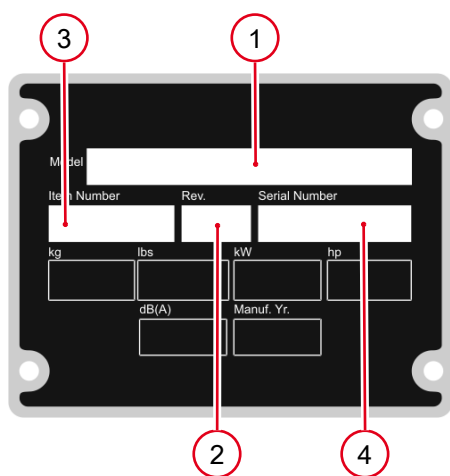

1. Typ
2. Version
3. Artikel-Nr.
4. Maschinen-Nr.

Table de conversion

Unité de volume	
1 ml	0.034 US fl.oz.
1 l	0.260 gal
Unité de longueur	
1 mm	0.039 in
1 m	3.280 ft
Poids	
1 kg	2.200 lbs
1 g	0.035 oz
Vitesse	
1 km/h	0.620 mph
Couple de serrage	
1 Nm	0.740 ft.lbs

Bestandteile Der Pumpe
Pump components
Piezas de la bomba
Parties constituantes de la po 8

Sonderzubehör
Accessories
Accesorios
Accessoires 14



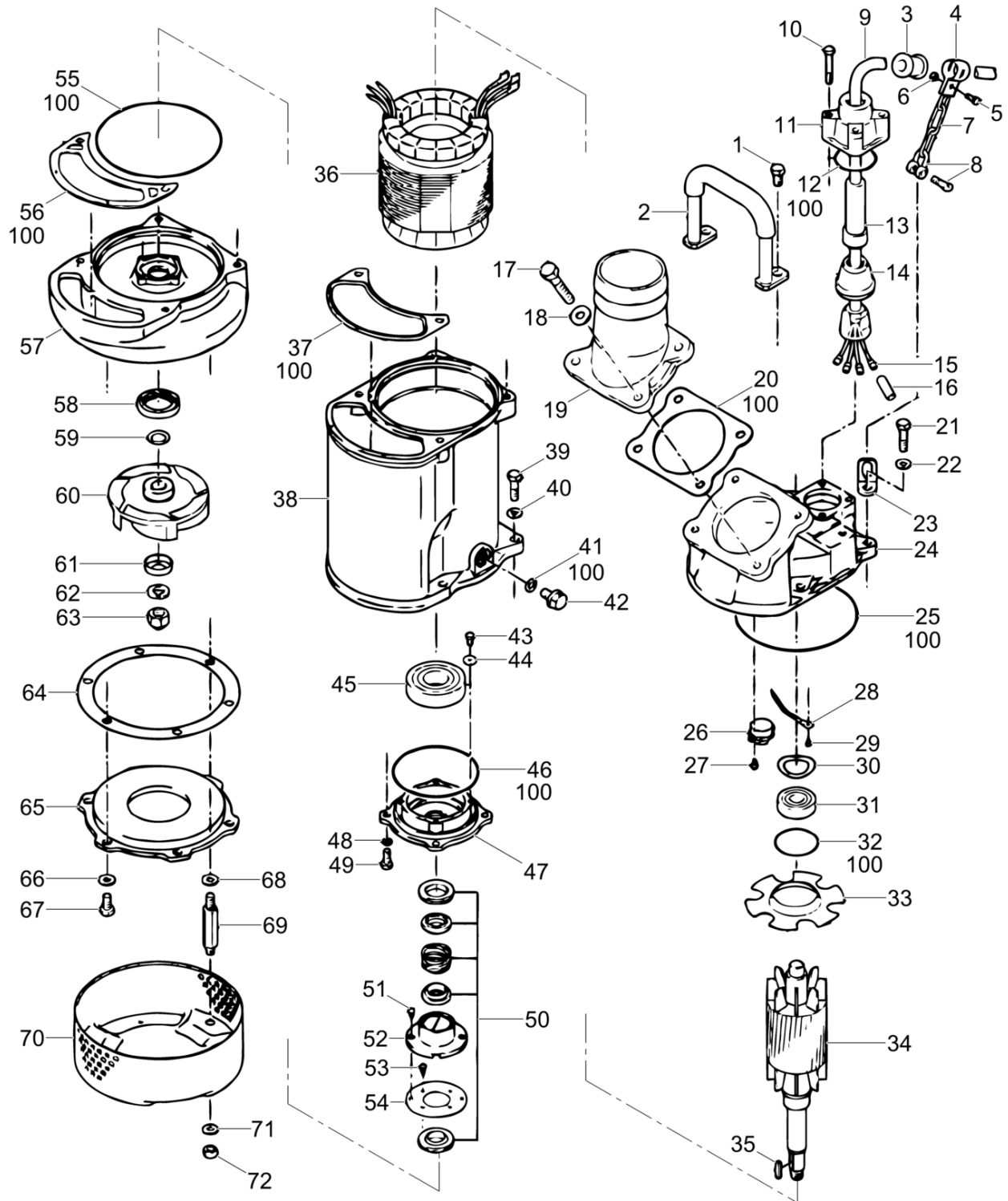

5200023425_01

Pos. Ref.	Artikel Nr. Part No.	Qty.	Unit	Beschreibung Descripcion	Description Description	Abm. Measur.	Norm Standard
						Drehm. Torque	Schmierstoff Sealant
1	5000150726	2	PC	Bolzen Perno	Bolt Boulon	M10 x 20	
2	5000150642	1	PC	Tragegriff Manija de levante	Lifting handle Poignée de relèvement		
3	5100029388	1	PC	Hülse Manguito	Sleeve Douille		
4	5000150450	1	PC	Befestigung Clip	Clip Clip		
5	5000150715	1	PC	Bolzen Perno	Bolt Boulon	M6 x 15	
6	5100028407	1	PC	Mutter Tuerca	Nut Écrou	M6	
7	5000150665	1	PC	Kette Cadena	Chain Chaîne		
8	5100028548	1	PC	Haken Gancho	Hook Croc		
9	5100029389	1	PC	Zuleitungskabel Cable	Power cable Câble	20m 415V-50Hz	
10	5000150722	4	PC	Bolzen Perno	Bolt Boulon	M8 x 50	
11	5000150423	1	PC	Umhüllung Envoltura	Casing Gaine		
12	5000150692	1	PC	O-Ring Anillo-o	O-ring Joint torique		
13	5000150420	1	PC	Buchse Buje	Bushing Douille		
14	5000150427	1	PC	Deckel Tapa	Cover Couvercle		
15	5000150430	4	PC	Winkelstecker Terminal	Terminal post Borne d'attache		
16	5000150416	1	PC	Schrumpfschlauch Tubo de contracción	Heat shrink tube Tube rétréci		
17	5200023039	4	PC	Bolzen Perno	Bolt Boulon	M10 x 35	
18	5100028656	1	PC	Scheibe Arandela	Washer Rondelle	M10	
19	5200023045	1	PC	Schlauchkupplung Mit Stecknippel Acoplamiento de mangueras con púas	Barbed hose coupling Accouplement de tuyau avec rac	4in	
20	5200023049	1	PC	Dichtung Junta	Gasket Joint		
21	5000150730	4	PC	Bolzen Perno	Bolt Boulon	M10 x 40	
22	5000150764	4	PC	Federring Federring	Lock washer Rondelle de ressort	M10	
23	5000150645	1	PC	Konsole Soporte	Bracket Support		
24	5100029390	1	PC	Gehäuse Caja	Housing Carter		
25	5000150701	1	PC	O-Ring Anillo-o	O-ring Joint torique		
26	5000162527	1	PC	Thermoschalter Interruptor térmico	Thermal switch Thermorupteur		
27	5000150783	2	PC	Schraube Tornillo	Screw Vis	M4 x 12	
28	5000152310	1	PC	Erdungsdraht Alambre a tierra	Ground wire Fil de masse		

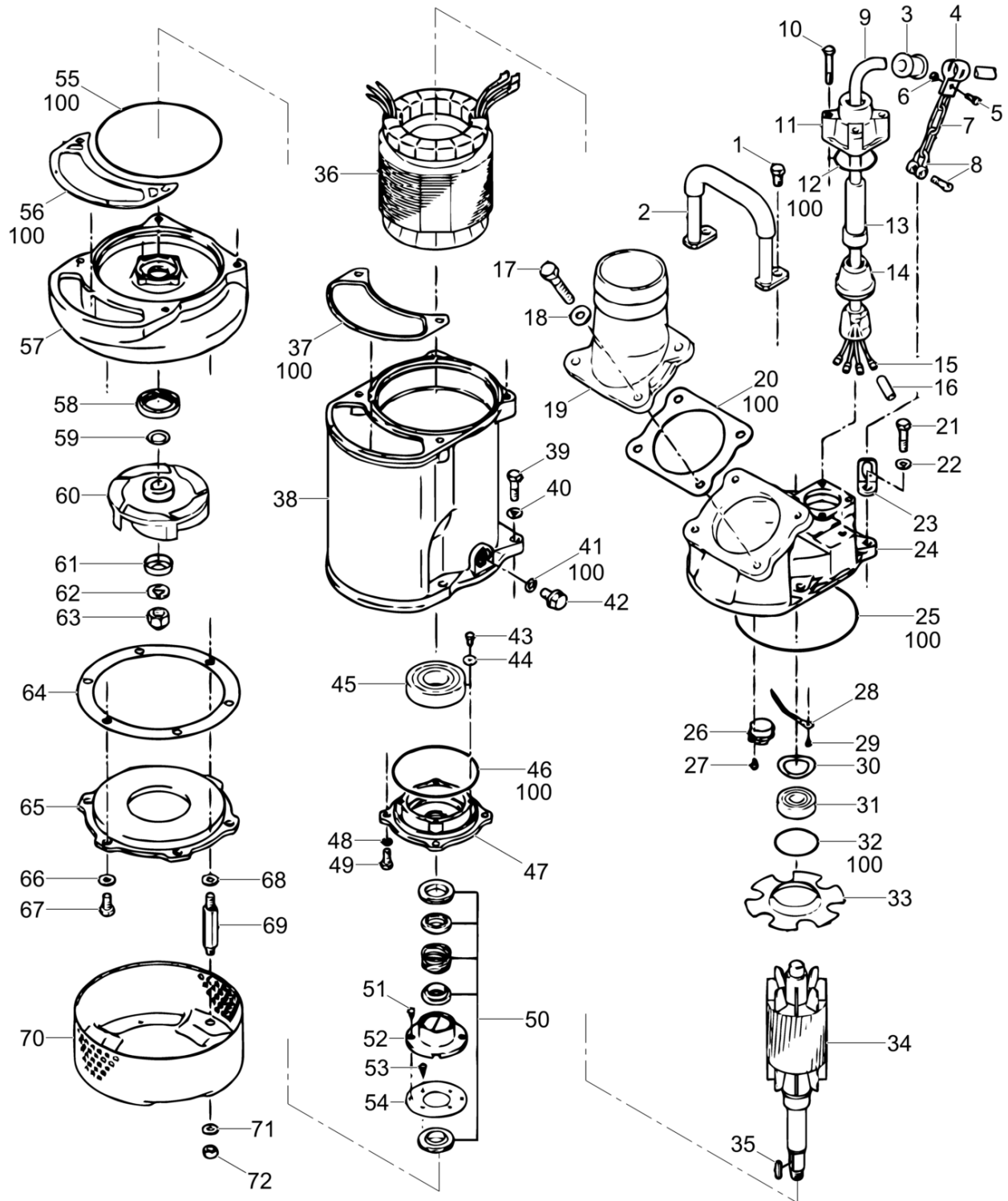

5200023425_01

Pos. Ref.	Artikel Nr. Part No.	Qty.	Unit	Beschreibung Descripcion	Description Description	Abm. Measur.	Norm Standard
						Drehm. Torque	Schmierstoff Sealant
29	5000177004	1	PC	Schraube Tornillo	Screw Vis	M4 x 6	
30	5000150768	1	PC	Tellerfeder Arandela de resorte	Spring washer Ressort belleville		
31	5000150558	1	PC	Kugellager Rodamiento de bolas	Ball bearing Roulement à billes		
32	5000150706	1	PC	O-Ring Anillo-o	O-ring Joint torique		
33	5000162528	1	PC	Schutzplatte Placa de protección	Protection plate Plaque de protection		
34	5200023051	1	PC	Rotor Rotor	Rotor Rotor		
35	5100028408	1	PC	Passfeder Llave	Key Clé	5 x 5 x 25	
36	5000162530	1	PC	Stator Estator	Stator Stator		
37	5000150689	1	PC	Dichtung Junta	Gasket Joint		
38	5100029391	1	PC	Motorgehäuse Caja del motor	Motor housing Cage du moteur		
39	5000150729	4	PC	Bolzen Perno	Bolt Boulon	M10 x 35	
40	5000150764	4	PC	Federring Federring	Lock washer Rondelle de ressort	M10	
41	5000150677	1	PC	Dichtung Junta	Gasket Joint		
42	5000150738	1	PC	Bolzen Perno	Bolt Boulon	M12 x 20	
43	5000176786	4	PC	Bolzen Mit Scheibe Perno con arandela	Bolt w/washer Boulon avec rondelle	M5x10	
44	5100028409	4	PC	Lagerdeckel Tapa del rodamiento	Bearing cover Tapa del rodamiento		
45	5000150560	1	PC	Kugellager Rodamiento de bolas	Ball bearing Roulement à billes		
46	5000150694	1	PC	O-Ring Anillo-o	O-ring Joint torique		
47	5200023055	1	PC	Lagergehäuse Caja del rodamiento	Bearing housing Logement du roulement		
48	5000150763	4	PC	Federring Federring	Lock washer Rondelle de ressort	M8	
49	5000150718	4	PC	Bolzen Perno	Bolt Boulon	M8 x 20	
50	5100028490	1	PC	Gleitringdichtung Sello mecánico	Mechanical seal Garniture mécanique		
51	5000150776	2	PC	Schraube Tornillo	Screw Vis	M5 x 6	
52	5000176980	1	PC	Steigrohr Tubo alzador	Oil lifter Tuyau de refoulement		
53	5100028211	4	PC	Schraube Tornillo	Screw Vis	M5 x 6	
54	5000150520	1	PC	Lagerplatte Placa de retención	Retaining plate Plaque d'arrêt		
55	5000150702	1	PC	O-Ring Anillo-o	O-ring Joint torique		
56	5000150671	1	PC	Dichtung Junta	Gasket Joint		

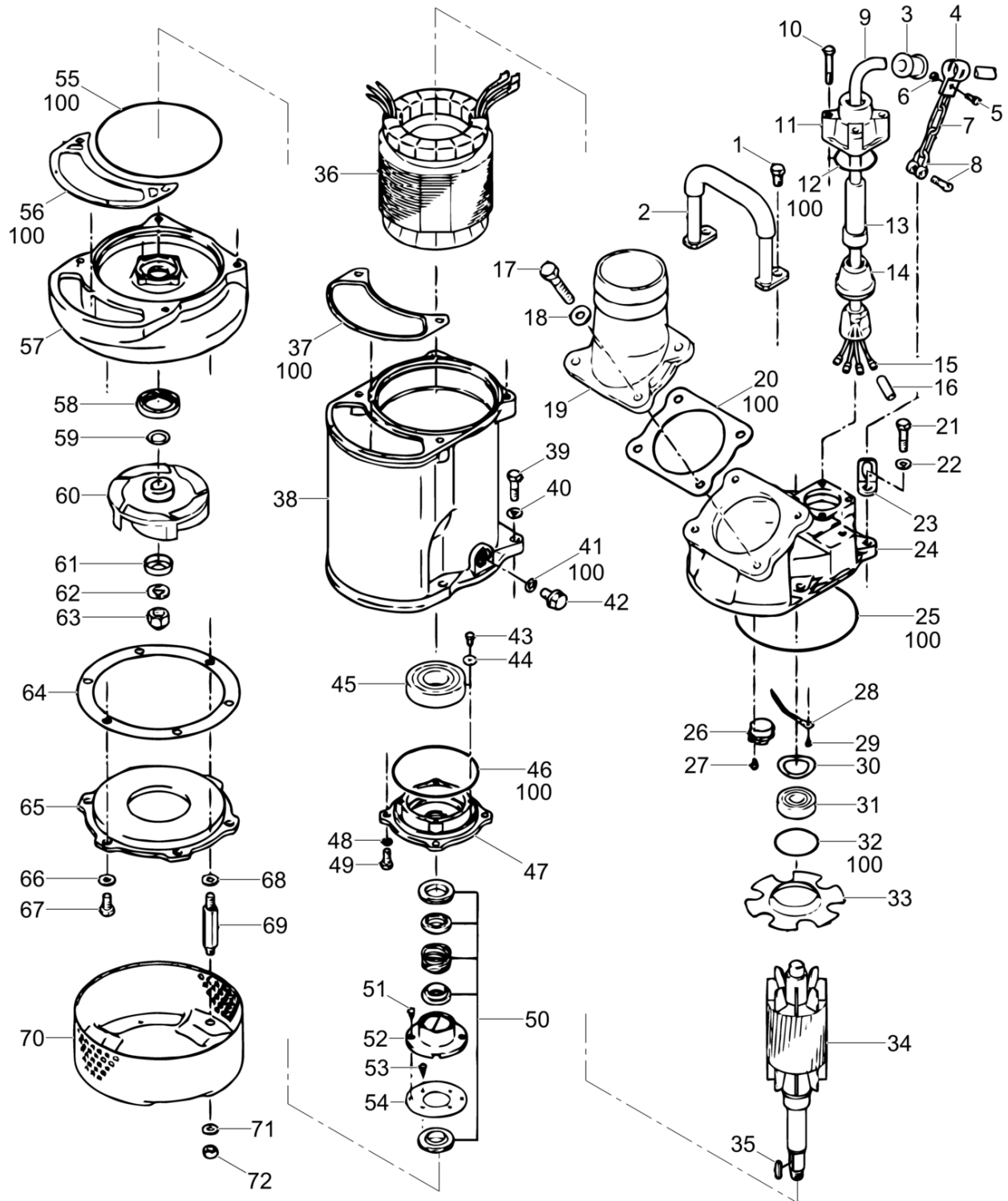

5200023425_01

Pos. Ref.	Artikel Nr. Part No.	Qty.	Unit	Beschreibung Descripcion	Description Description	Abm. Measur.	Norm Standard
						Drehm. Torque	Schmierstoff Sealant
57	5000150466	1	PC	Spiralgehäuse Voluta	Volute Volute		
58	5000150510	1	PC	Öldichtung Empaque de aceite	Oil seal Joint d'huile		
59	5000150539	1	PC	Ausgleichscheibe Laminita	Shim Cale		
60	5000150474	1	PC	Pumpenlaufrad Impulsor	Impeller Rotor avec aubes		
61	5000150541	1	PC	Deckel Tapa	Cover Couvercle		
62	5000150765	1	PC	Federring Federring	Lock washer Rondelle de ressort		
63	5000150755	1	PC	Hutmutter Tuerca	Acorn nut Ecrou	M16	
64	5000150667	1	PC	Dichtung Junta	Gasket Joint		
65	5000150491	1	PC	Deckel Tapa	Cover Couvercle		
66	5000150761	3	PC	Scheibe Arandela	Washer Rondelle	M10	
67	5000150726	3	PC	Bolzen Perno	Bolt Boulon	M10 x 20	
68	5000150761	3	PC	Scheibe Arandela	Washer Rondelle	M10	
69	5100028492	3	PC	Gewindebolzen Perno prisionero	Stud bolt Boulon	M10 x 94	
70	5000150497	1	PC	Sieb Tamizador	Strainer Tamis		
71	5000150761	3	PC	Scheibe Arandela	Washer Rondelle	M10	
72	5000150747	3	PC	Mutter Tuerca	Nut Écrou	M10	
100	5100028493	1	PC	Dichtungs- U. O-Ringsatz Juego de juntas/anillos-o	Gasket & o-ring set Jeu de joints		



1

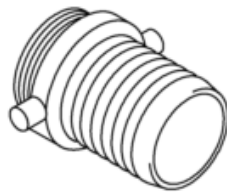

2

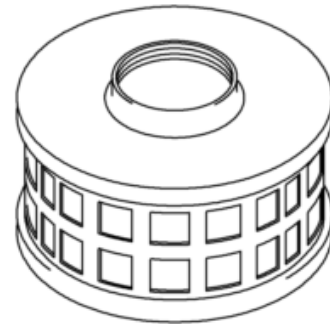

3



4

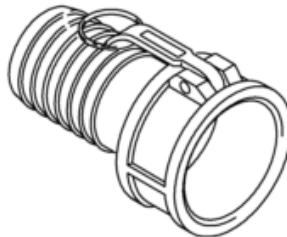

5

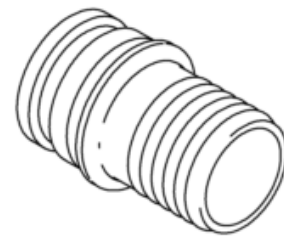

6

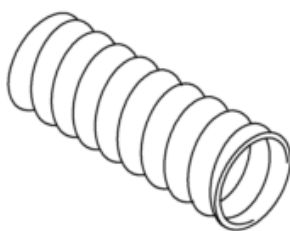

7

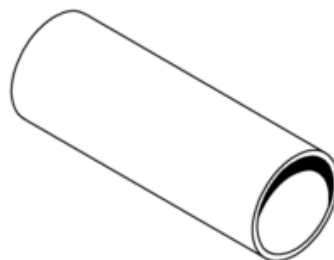

8

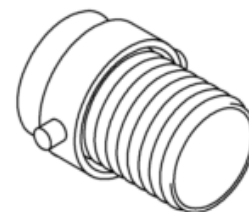

9

wc_gr001134

Pos. Ref.	Artikel Nr. Part No.	Qty.	Unit	Beschreibung Description	Description Description	Abm. Measur.	Norm Standard
						Drehm. Torque	Schmierstoff Sealant
1	5002005959	1	PC	Schlauchschelle Abrazadera	Clamp Agrafe	4-1/2in	
2	5000028074	1	PC	Schlauchstutzen Acoplamiento	Coupling Accouplement	101mm/4in	
4	5000051451	1	PC	Kupplung Acoplamiento rápido	Quick disconnect coupling Raccord express	101mm/4in	
5	5000051454	1	PC	Kupplung Acoplamiento	Coupling Accouplement	101mm/4in	
6	5000070341	1	PC	Schnellverschluß Acoplamiento rápido	Quick disconnect coupling Raccord express	101mm/4in	
7	5000028070	1	PC	PVC-Spiralsaugschlauch Manguera de succión	Suction hose Tuyau de succion	4 x 240in	
8	5000028069	1	M	Druckschlauch Manguera de descarga	Discharge hose Tuyau d'écoulement	4in	
9	5000028075	1	PC	Kupplung Acoplamiento	Coupling Accouplement	101mm/4in	
10	5000053389	1	PC	Dichtung Junta	Gasket Joint		
11	5000028076	1	PC	Dichtung Junta	Gasket Joint		
12	5000054345	1	PC	Schnellverschluß Acoplamiento rápido	Quick disconnect coupling Raccord express	110	
13	5000059980	1	PC	Dichtung Junta	Gasket Joint	110	
14	5000151080	1	PC	Abzieher Extractor	Puller Appareil de traction		



**WACKER
NEUSON**

