



**WACKER
NEUSON**

0630060	103
06.2014	

**Single Direction Plates
Vorwärtslaufende Platten
Planchas Vibradoras Unidirecc
Plaques Vibrantes à sens de ma**

VP 1135AW

**Parts Book
Ersatzteile
Lista de Repuestos
Liste de Pièces de Rechange**

www.wackerneuson.com

A nameplate listing the Model Number, Item Number, Revision, and Serial Number is attached to each unit. Please record the information found on this plate so it will be available should the nameplate become lost or damaged. When ordering parts or requesting service information, you will always be asked to specify the model, item number, revision number, and serial number of the unit.

Ein Typenschild mit Typ, Artikelnummer, Version und Maschinen-Nummer ist an jedem Gerät angebracht. Die Daten von diesem Schild bitte notieren, damit sie auch bei Verlust oder Beschädigung des Schildes noch vorhanden sind. Der Typ, die Artikel-Nummer, die Versions- Nummer und die Maschinen-Nummer sind bei der Ersatzteilbestellung oder Nachfragen bezüglich Service-Informationen stets erforderlich.

Una placa de identificación con el modelo, número de referencia, nivel de revisión y número de serie ha sido añadida en cada máquina. Favor de anotar los datos en la placa en caso de que la placa de identificación sea destruida o perdida. En todos los pedidos para repuestos necesita siempre el modelo, el número de referencia, el nivel de revisión y el número de serie de la máquina en cuestión.

Une plaque signalétique mentionnant le modèle, le numéro de référence, le niveau de révision et le numéro de série est fixée sur chaque machine. Veuillez noter les informations relevées sur cette plaque de façon à ce qu'elles soient toujours disponibles si la plaque signalétique venait à être perdue ou endommagée. Lorsque vous commandez des pièces détachées ou vous sollicitez des informations après-vente, on vous demandera toujours de préciser le modèle, le numéro de référence, le niveau de révision et le numéro de série de la machine.

***My machine's numbers are / Die Nummern meines Gerätes sind /
Los números de mi máquina son / Les numéros de ma machine son :***



Part Numbers appearing in boldface type are recommended spare parts. This means that these parts are subject to wear under normal operating conditions and may require periodic service or replacement. It is recommended that these items be stocked to meet the expected service requirements of this model. Actual stocking quantities of these and other parts used in more extensive repairs will depend on the service practices of each customer.

Bei den in den Ersatzteillisten fettgedruckten Nummern handelt es sich um empfohlene Ersatzteile. Dies bedeutet, daß diese Teile bei normalen Anwendungsbedingungen natürlicher Abnutzung ausgesetzt sind und gelegentlich ersetzt oder überarbeitet werden müssen. Es wird geraten, diese Teile auf Lager bereit zu haben, um für Service-Arbeiten an diesem Gerät vorbereitet zu sein. Lagerbestände für diese und andere Teile, welche für ausgiebigere Reparaturarbeiten benötigt werden, können je nach Service-Gewohnheiten der einzelnen Kunden variieren.

Los números de partes en negritas en las Listas Ilustradas de Partes son los repuestos recomendados, ésto quiere decir que estas partes se desgastarán bajo circunstancias de funcionamiento normales y pueden requerir servicio periódico o su reemplazo. Se recomienda que el cliente mantenga un abastecimiento adecuado de estas partes para poder satisfacer la demanda requerida por el servicio a la máquina. La cantidad de repuestos que el cliente necesitará para reparaciones dependerá de la póliza de servicio de cada cliente.

Les numéros de pièces imprimés en caractères gras dans les Listes des Pièces Détachées de ce manuel sont les pièces détachées recommandées par la Wacker. Cela veut dire que ces pièces sont sujettes à usure dans des conditions de travail normales et peuvent nécessiter de l'entretien ou leur remplacement. Nous recommandons que vous disposez d'un stock de ces pièces pour pouvoir satisfaire la demande d'entretien de cette machine. Le client doit décider lui-même de la quantité exacte de pièces de rechange qu'il disposera dans ses stocks.

Baseplate/Console cpl. Grundplatte/Konsole kpl. Plancha-basa/Consola compl. Base/Console compl.	8
Drive cpl. Antrieb kpl. Sistema Impulsor compl. Entraînement compl.	12
Clutch cpl. Kupplung kpl. Embrague compl. Embrayage compl.	14
Water System Kit Berieselungsanlage Juego de Sistema de Agua Jeu de Système d'Eau	16
Label Aufkleber Calcomania Autocollant	18
Engine-Honda Honda-Motor Motor Honda Moteur Honda	21
Engine Block Motor Motor Moteur	22
Cylinder Head Zylinderkopf Culata Culasse	24
Crankcase Cover Kurbelgehäusedeckel Tapa del Cáster Couvercle de Carter	26
Camshaft Nockenwelle Arbol de levas Arbre à cames	28
Fuel Tank cpl. Kraftstofftank kpl. Depósito de Combustible compl. Réservoir de carburant compl.	30
Blower Housing Lüftergehäuse Cubierta Bouclier	32
Starter cpl. Starter kpl. Arrancador compl. Démarreur compl.	34
Carburetor cpl. Vergaser kpl. Carburador compl. Carburateur compl.	36

Piston/Crankshaft Kolben/Kurbelwelle Pistón/Cigüeñal Piston/Vilebrequin	40
Flywheel Schwungrad Volante Volant	42
Ignition Zündung Encendido Allumage	44
Governor Regler Regulador Régulateur	46
Air Cleaner Luftfilter Filtro del Aire Filtre à Air	48
Muffler Auspufftopf Silenciador Pot d'échappement	50
Accessories Sonderzubehör Accesorios Accessoires	53
Protective Pad Kit Plattengleitvorrichtung Colchoneta para losas Dispositif à pavés	54
Wheel Kit Radsatz Juego de Rueda Jeu de Roue	56

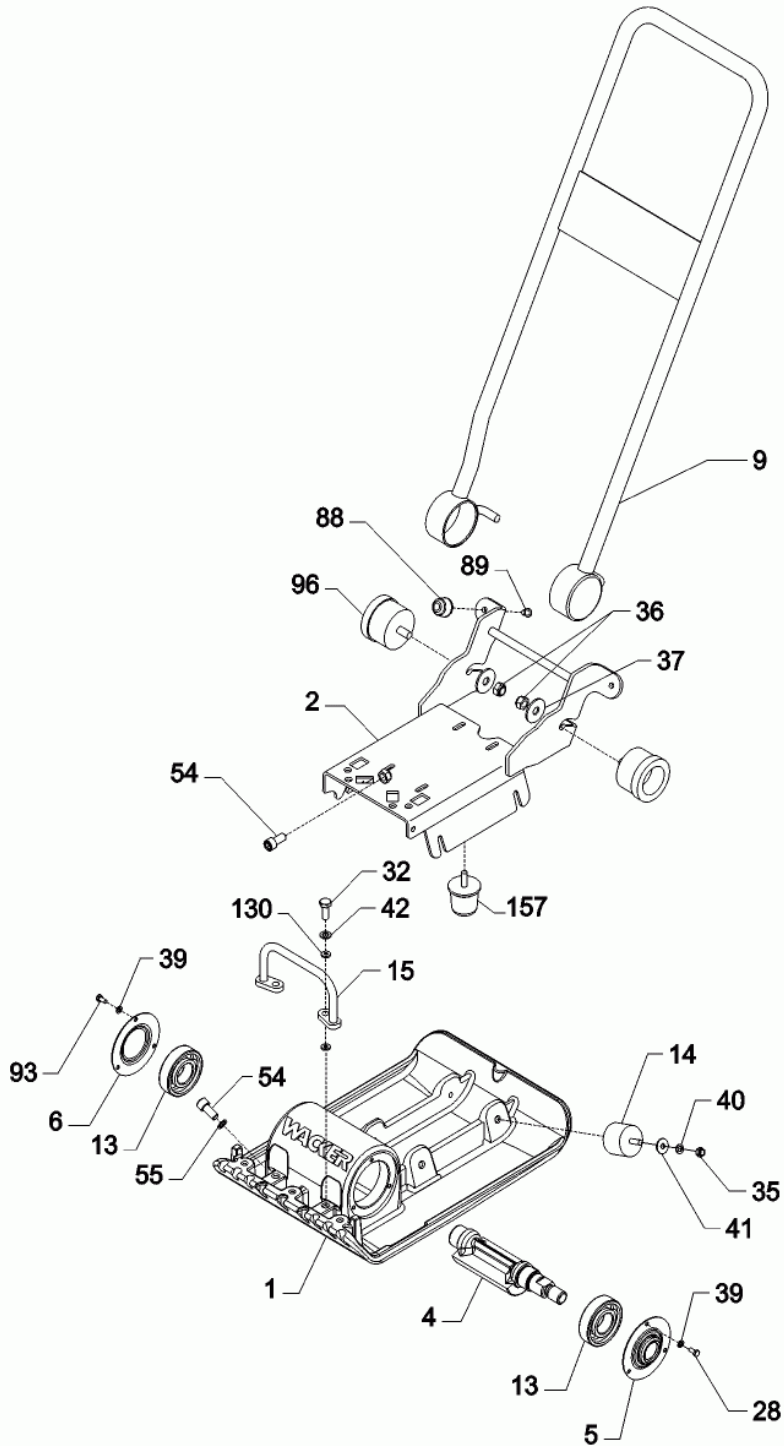

wpmex0009251114_01

Ref. Pos.	Part No. Artikel Nr.	Qty. St.	Description Beschreibung	Descripción Description	Measurement./Abm.	Norm
					Torque/Drehm.	Sealant Schmierstoff
1	0401264	1	Baseplate Grundplatte	Plancha-basa Base	35cm	
2	0401609	1	Console Bedienungskonsole	Pupitre de mando Panneau de contrôle		
4	0114169	1	Exciter shaft Erregerwelle	Eje del excitador Arbre de l'excitatrice		
5	0155430	1	End cap w/seal Endkappe mit Dichtung	Tapa con empaque Couvercle avec joint		
6	0115054	1	Cap Kappe	Tapa Capuchon		S10
9	0130569	1	Guide handle cpl. Führungsbügel kpl.	Manija compl. Poignée compl.		
13	0114484	2	Ball bearing Kugellager	Rodamiento de bolas Roulement à billes		
14	0130014	4	Shockmount Puffer	Amortiguador Silentbloc		
15	0130854	1	Lifting Handle Kit Tragegriffsatz	Manija de levante compl. Poignée de relèvement compl.		
28	0012357	5	Hexagonal head cap screw Sechskantschraube	Tornillo hexagonal Boulon à tête hexagonale	M6 x 12 8Nm/6ft.lbs	DIN 933 S3
32	0011440	2	Hexagonal head cap screw Sechskantschraube	Tornillo hexagonal Boulon à tête hexagonale	M10 x 25 49Nm/36ft.lbs	DIN 933 S3
35	0010367	4	Hexagon nut Sechskantmutter	Tuerca hexagonal Écrou hexagonal	M8 21Nm/15ft.lbs	DIN 985
36	0010366	2	Hexagon nut Sechskantmutter	Tuerca hexagonal Écrou hexagonal	M12	DIN 985
37	0114766	2	Flat washer Scheibe	Arandela elástica Rondelle de ressort	0,531 x 1,625 x 0,12	
39	0010649	6	Lock washer Federring	Federring Rondelle de ressort	B6	DIN 127
40	0012397	4	Lock washer Federring	Federring Rondelle de ressort	B8	DIN 127
41	0010374	4	Flat washer Scheibe	Arandela elástica Rondelle de ressort	B8,4	DIN 9021
42	0033988	2	Lock washer Federring	Federring Rondelle de ressort	10	DIN 6796
54	0017086	1	Socket head cap screw Zylinderschraube	Tornillo cilíndrico Vis à tête cylindrique	M12 x 25 120Nm/89ft.lbs	DIN 912
55	0013444	1	Ring seal Dichtungsring	Anillo sellador Rondelle à étancher	A12 x 18	DIN 7603
88	0105056	2	Shockmount Puffer	Amortiguador Silentbloc	M30 x 20	
89	0012360	2	Hexagonal head cap screw Sechskantschraube	Tornillo hexagonal Boulon à tête hexagonale	M8 x 12 21Nm/15ft.lbs	DIN 933 S3
93	0011470	1	Hexagonal head cap screw Sechskantschraube	Tornillo hexagonal Boulon à tête hexagonale	M6 x 20 10Nm/7ft.lbs	DIN 933
96	0130064	2	Shockmount Puffer	Amortiguador Silentbloc		
130	0130787	4	Spacer Abstandsstück	Espaciador Entretoise		

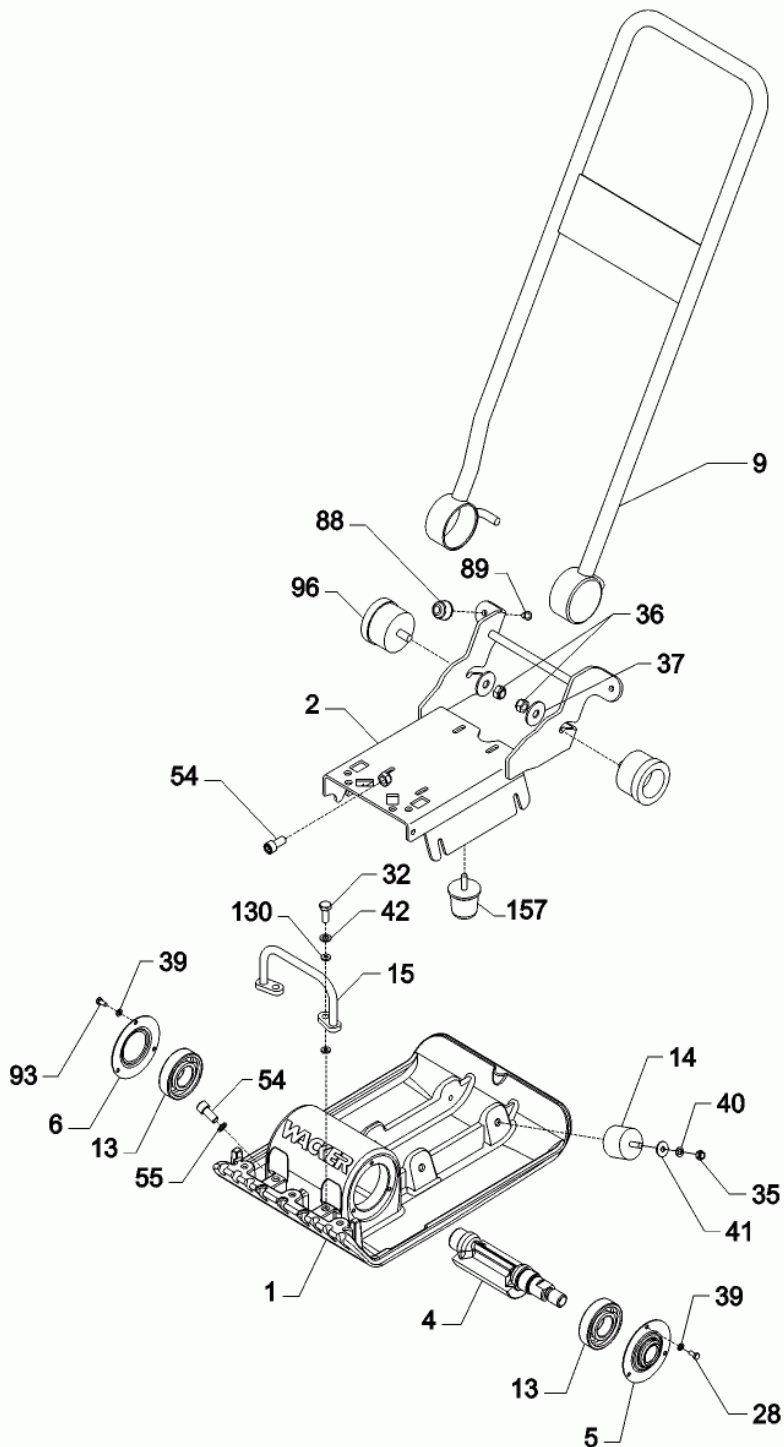

wpmex0009251114_01

VP 1135AW

Baseplate/Console cpl.
Grundplatte/Konsole kpl.
Plancha-basa/Consola compl.
Base/Console compl.

Ref. Pos.	Part No. Artikel Nr.	Qty. St.	Description Beschreibung	Descripción Description	Measurement/Abm.	Norm
					Torque/Drehm.	Sealant Schmierstoff
157	0130961	1	Shockmount Puffer	Amortiguador Silentbloc		

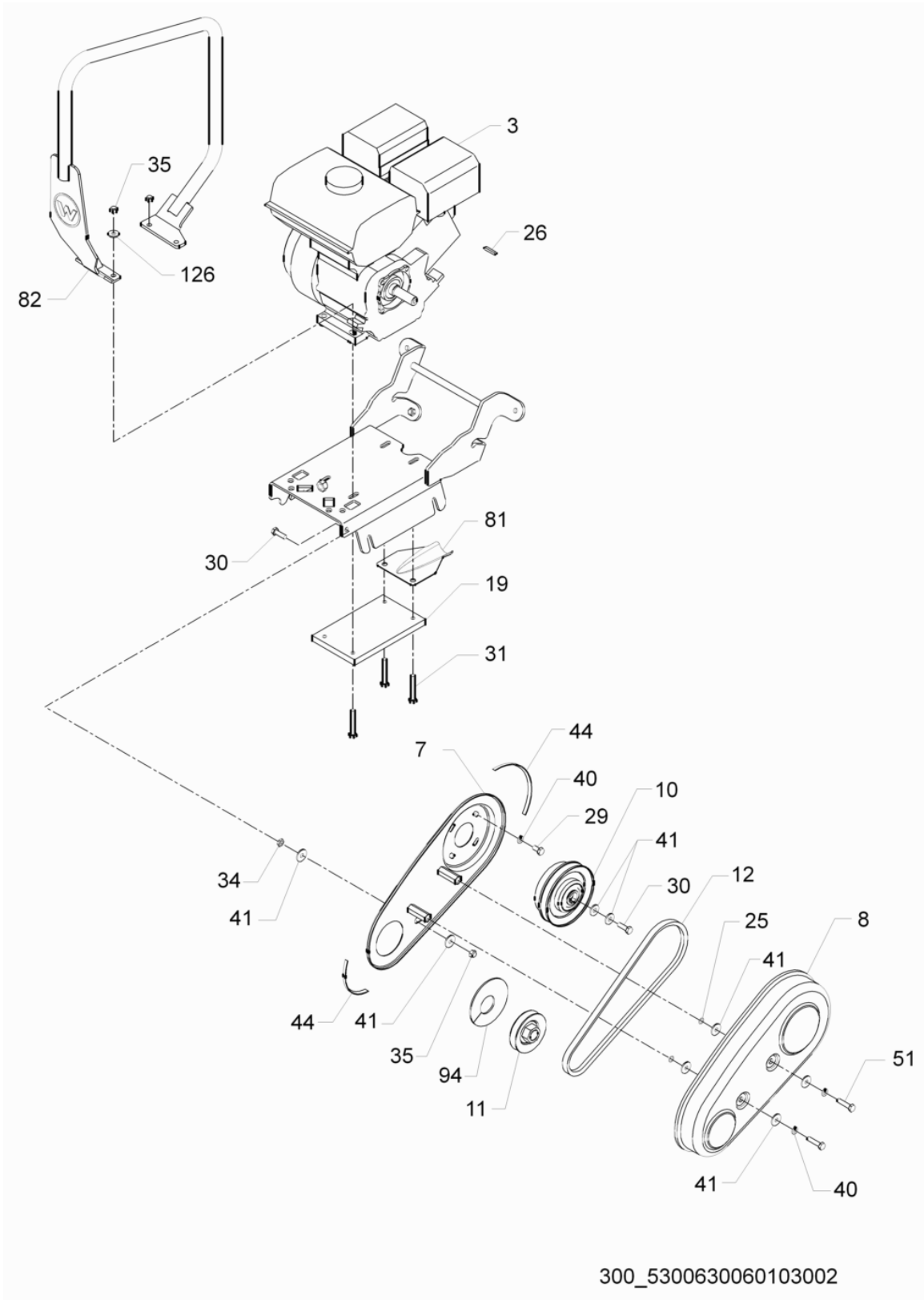

Ref. Pos.	Part No. Artikel Nr.	Qty. St.	Description Beschreibung	Descripción Description	Measurement./Abm.	Norm
					Torque/Drehm.	Sealant Schmierstoff
2	0401609	1	Console Bedienungskonsole	Pupitre de mando Panneau de contrôle		
3	0400020	1	Engine-Honda Honda-Motor	Motor Honda Moteur Honda		
7	0400741	1	Beltguard Riemenschutz	Guardacorrea Protection de courroie		
8	0114174	1	Beltguard Riemenschutz	Guardacorrea Protection de courroie		
10	0130047	1	Clutch Kupplung	Embrague Embrayage		
11	0130522	1	Pulley Scheibe	Polea Poulie		
12	0114178	1	V-belt Keilriemen	Correa en V Courroie trapézoïdale		
19	0114763	1	Console Bedienungskonsole	Pupitre de mando Panneau de contrôle		
25	0400406	2	E-Ring E-Ring	E-Anillo E-Anneau		
26	0013838	1	Square key Passfeder	Chaveta Clavette	A5 x 5 x 30	DIN 6885
29	0012361	4	Hexagonal head cap screw Sechskantschraube	Tornillo hexagonal Boulon à tête hexagonale	M8 x 16 21Nm/15ft.lbs	DIN 933
30	0011457	2	Hexagonal head cap screw Sechskantschraube	Tornillo hexagonal Boulon à tête hexagonale	M8 x 25 21Nm/15ft.lbs	DIN 933 S3
31	0011451	4	Hexagonal head cap screw Sechskantschraube	Tornillo hexagonal Boulon à tête hexagonale	M8 x 55 25Nm/18ft.lbs	DIN 933
34	0010805	1	Nut Mutter	Tuerca Écrou	BM8 21Nm/15ft.lbs	DIN 439 S5
35	0010367	5	Hexagon nut Sechskantmutter	Tuerca hexagonal Écrou hexagonal	M8 21Nm/15ft.lbs	DIN 985
40	0012397	6	Lock washer Federring	Federring Rondelle de ressort	B8	DIN 127
41	0010374	8	Flat washer Scheibe	Arandela elástica Rondelle de ressort	B8,4	DIN 9021
44	0116305	2	Molding Kit Profilgummissatz	Juego de moldura Jeu de garniture		
51	0401840	2	Hexagonal head cap screw Sechskantschraube	Tornillo hexagonal Boulon à tête hexagonale		
81	0117485	1	Oil drain Ölwanne	Chapa de purgado Cuvette d'huile		
82	0130851	1	Lift cage Schutzbügel	Protección del motor Protection de moteur		
94	0130040	1	Stone guard Steinschutz	Guardapiedra Pare-pierres		
126	0010621	2	Flat washer Scheibe	Arandela elástica Rondelle de ressort	B10,5	DIN 125

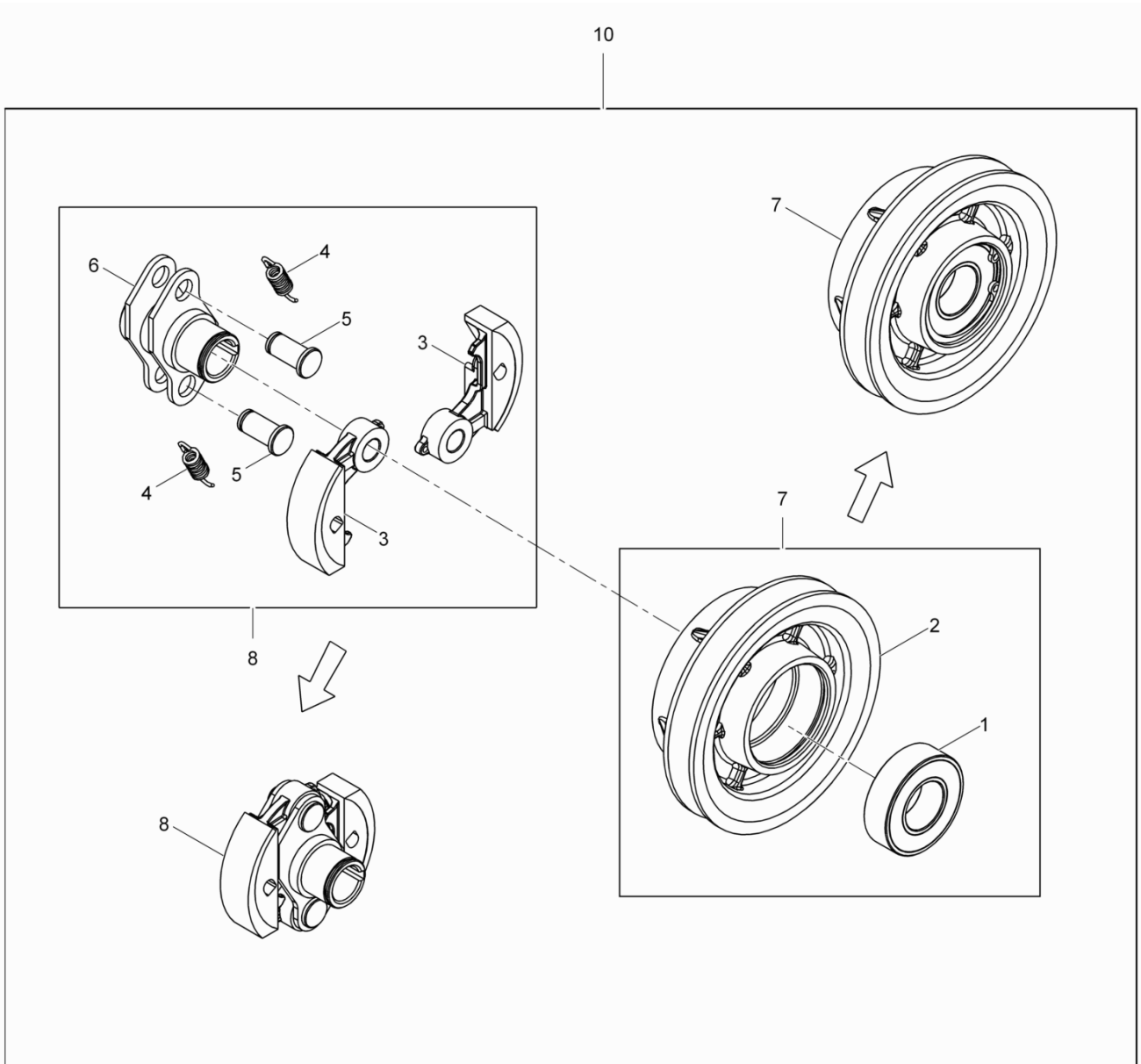

300_5300630059101003

Ref. Pos.	Part No. Artikel Nr.	Qty. St.	Description Beschreibung	Descripción Description	Measurement./Abm.	Norm
					Torque/Drehm.	Sealant Schmierstoff
1	0130162	1	Ball bearing Kugellager	Rodamiento de bolas Roulement à billes		
2	0130160	1	Clutch drum Fliehkraftglocke	Campana de embrague Carter d'embrayage		
3	0130153	2	Shoe-clutch Belagbügel	Peso de embrague Poids d'embrayage		
4	0130158	2	Spring Feder	Resorte Ressort		
5	0130157	2	Pin Stift	Pasador Goupille		
6	0130156	1	Clutch hub Kupplungsnahe	Cubo del embrague Moyeu d'embrayage		
7	0130149	1	Clutch drum Fliehkraftglocke	Campana de embrague Carter d'embrayage		
8	0130052	1	Shoe-clutch Belagbügel	Peso de embrague Poids d'embrayage		
10	0130047	1	Clutch Kupplung	Embrague Embrayage		

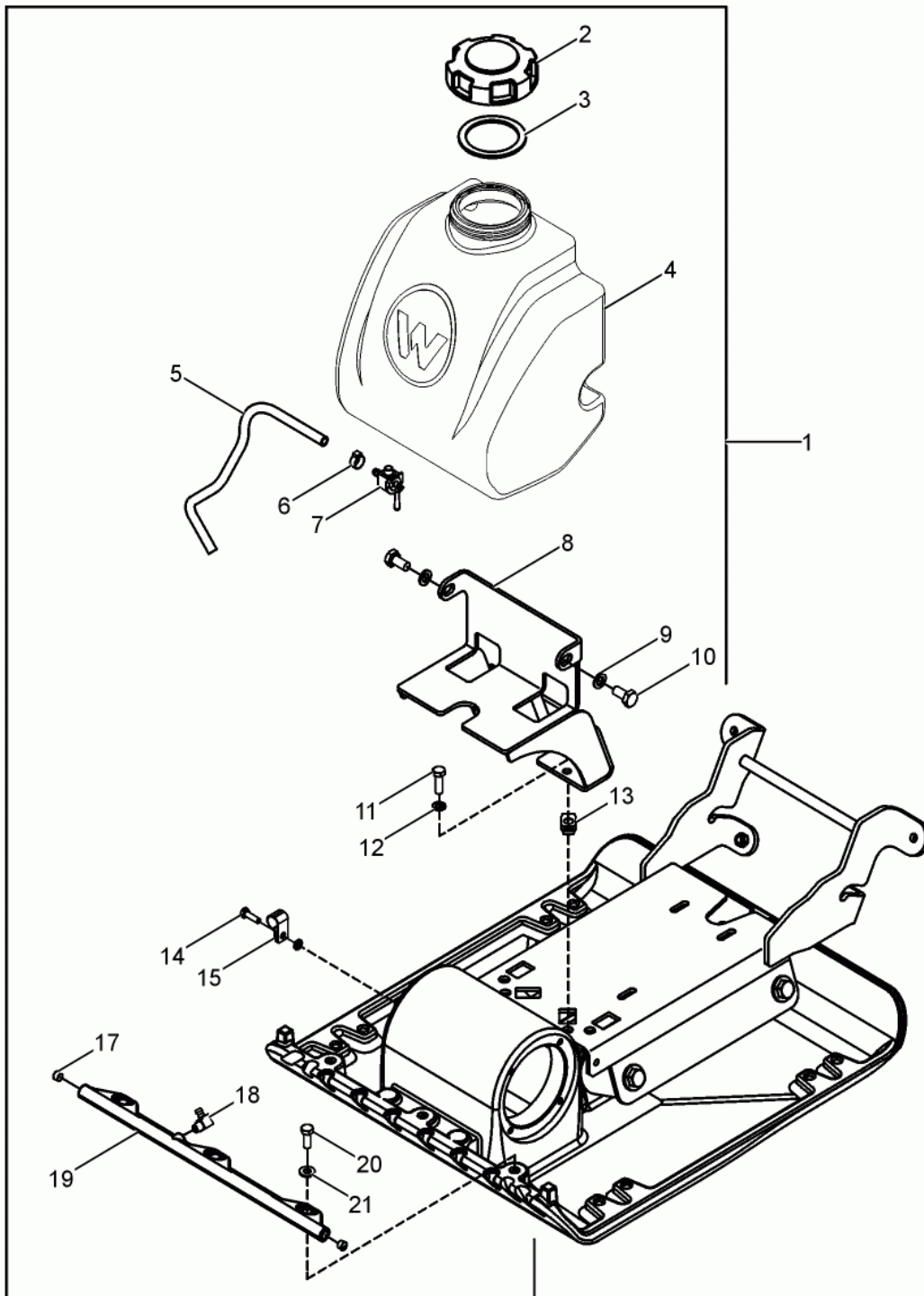

wpmex0130524101

Ref. Pos.	Part No. Artikel Nr.	Qty. St.	Description Beschreibung	Descripción Description	Measurem./Abm.	Norm
					Torque/Drehm.	Sealant Schmierstoff
1	0130375	1	Water System Kit Berieselungsanlage	Juego de Sistema de Agua Jeu de Système d'Eau		
2	0130374	1	Water tank cap Tankdeckel	Tapa del tanque Chapeau de réservoir		
3	0130641	1	Seal Dichtung	Empaque Joint		
4	0401555	1	Water tank Wassertank	Depósito de Agua Réservoir d'Eau		
5	2005049	1	Fuel hose Kraftstoffleitung	Manguera de combustible Tuyau de carburant	3/16 x 13in	
6	0033877	1	Clamp Schelle	Abrazadera Agrafe		
7	0027149	1	Shutoff valve Kraftstoffhahn	Grifo Robinet		
8	0400539	1	Bracket Konsole	Soporte Support		
9	0033988	2	Lock washer Federring	Federring Rondelle de ressort	10	DIN 6796
10	0012364	2	Hexagonal head cap screw Sechskantschraube	Tornillo hexagonal Boulon à tête hexagonale	M10 x 20 49Nm/36ft.lbs	DIN 933
11	0011457	4	Hexagonal head cap screw Sechskantschraube	Tornillo hexagonal Boulon à tête hexagonale	M8 x 25 25Nm/18ft.lbs	DIN 933
12	0012397	4	Lock washer Federring	Federring Rondelle de ressort	B8	DIN 127
13	0110969	4	Clip nut Klemmutter	Sujetador Agrafe	M8	
14	0011470	1	Hexagonal head cap screw Sechskantschraube	Tornillo hexagonal Boulon à tête hexagonale	M6 x 20 10Nm/7ft.lbs	DIN 933
15	0130003	1	Clamp Schelle	Abrazadera Agrafe		
17	0400300	2	Plug Stopfen	Tapón Bouchon		
18	0403537	1	Fitting Verschraubung	Unión Raccord		
19	0400302	1	Water Manifold cpl. Wasser-Verteiler kpl.	Distribuidor del agua compl. Rampe d'arrosage compl.	40cm	
20	0012362	3	Hexagonal head cap screw Sechskantschraube	Tornillo hexagonal Boulon à tête hexagonale	M8 x 20 25Nm/18ft.lbs	DIN 933
21	0033198	3	Lock washer Federring	Federring Rondelle de ressort	B8	DIN 6796

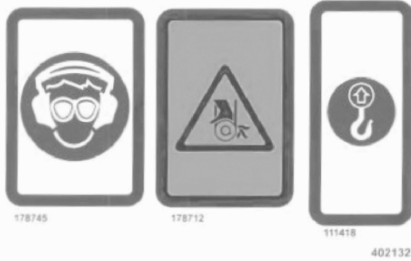

211



213

VP 1135
LOW VIB

129



92

WACKER
NEUSON

200



210



212

wpmex0630059100_04

Ref. Pos.	Part No. Artikel Nr.	Qty. St.	Description Beschreibung	Descripción Description	Measurem./Abm.	Norm
					Torque/Drehm.	Sealant Schmierstoff
92	0153795	1	Label Aufkleber	Calcomania Autocollant		
129	0401533	1	Label Aufkleber	Calcomania Autocollant		
200	0401565	1	Label Aufkleber	Calcomania Autocollant		
210	0401561	1	Label Aufkleber	Calcomania Autocollant		
211	0402132	1	Label Aufkleber	Calcomania Autocollant		
212	0401907	1	Label-engine Aufkleber-Motor	Calcomania-motor Autocollant-moteur		
213	0402131	1	Label sheet Aufkleberblatt	Hoja de calcomanias Feuille d'autocollants		



**WACKER
NEUSON**

**Engine-Honda
Honda-Motor
Motor Honda
Moteur Honda**

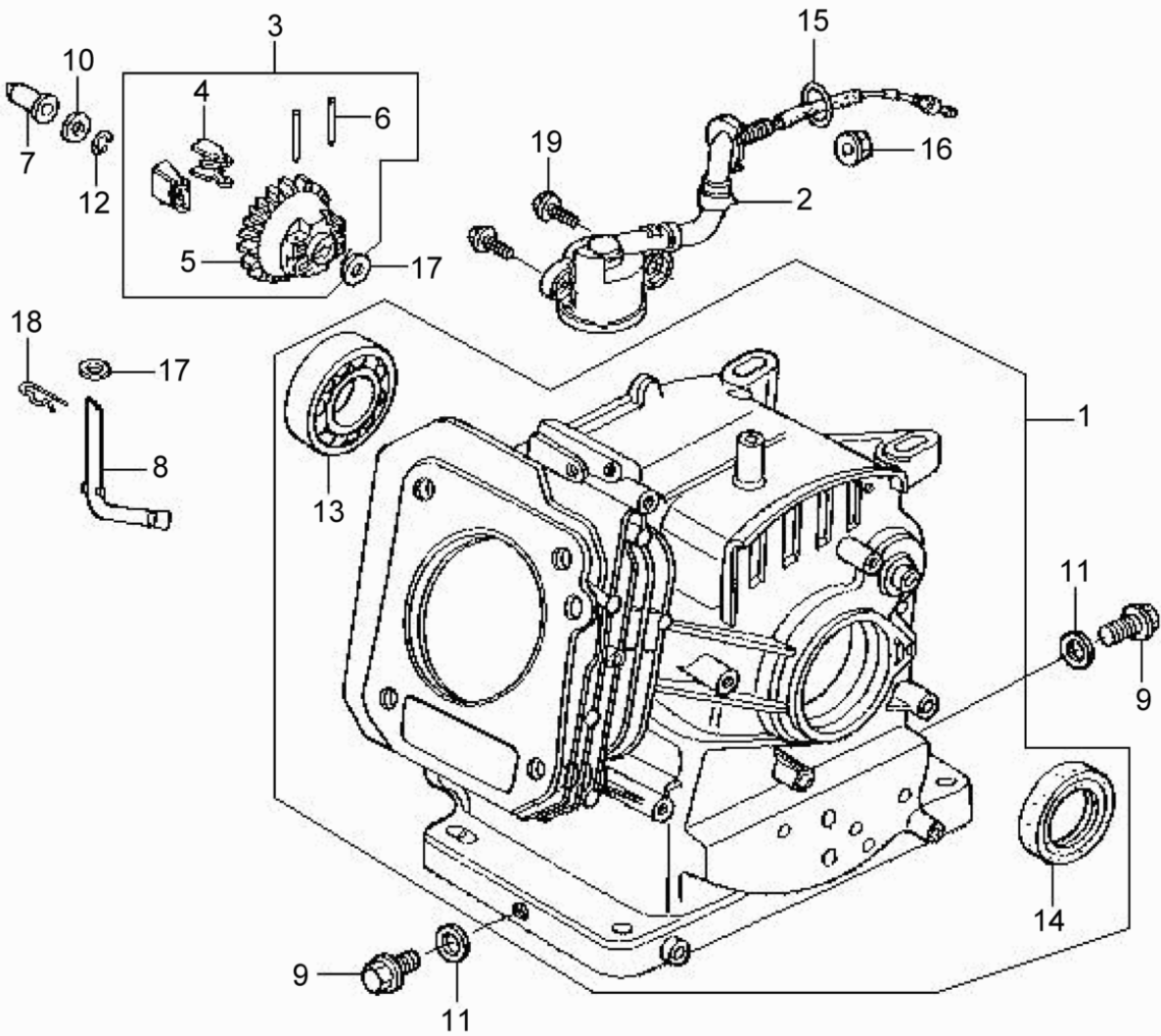

300_5000400020101001

Ref. Pos.	Part No. Artikel Nr.	Qty. St.	Description Beschreibung	Descripción Description	Measurem./Abm.	Norm
					Torque/Drehm.	Sealant Schmierstoff
1	0209782	1	Cylinder Zylinder	Cilindro Cylindre		
2	0216513	1	Oil switch cpl. Ölschalter kpl.	Interruptor de Aceite compl. Interrupteur de Huile compl.		
3	0076934	1	Governor cpl. Regler kpl.	Regulador compl. Régulateur compl.		
4	0151694	2	Weight Gewicht	Peso Poids		
5	0151695	1	Holder Halter	Soporte Attache		
6	0156689	2	Pin Stift	Pasador Goupille		
7	0070953	1	Slider Gleitstück	Manguito Douille		
8	0107060	1	Governor lever Reglerhebel	Palanca del gobernador Lever régulateur		
9	0070964	2	Plug (threaded) Schraubverschluß	Tapón roscado Bouchon		
10	0070959	1	Washer Scheibe	Arandela Rondelle		
11	0070963	2	Washer Scheibe	Arandela Rondelle		
12	0081615	1	Retaining ring Sicherungsring	Anillo de retención Bague d'arrêt		
13	0070961	1	Ball bearing Kugellager	Rodamiento de bolas Roulement à billes		
14	0070962	1	Shaft seal Wellendichtring	Sello del eje Bague d'étanchéité		
15	0071082	1	O-Ring O-Ring	Anillo-O Joint torique	14 x 1,3	
16	0072332	1	Flange nut Flanschmutter	Tuerca de reborde Ecroû de bride	M10	
17	0071639	2	Washer Scheibe	Arandela Rondelle	6M	
18	0054033	1	Pin Stift	Pasador Goupille		
19	0072333	2	Flange bolt Flanschbolzen	Perno de reborde Boulon à bride	M6 x 12 10Nm/7ft.lbs	

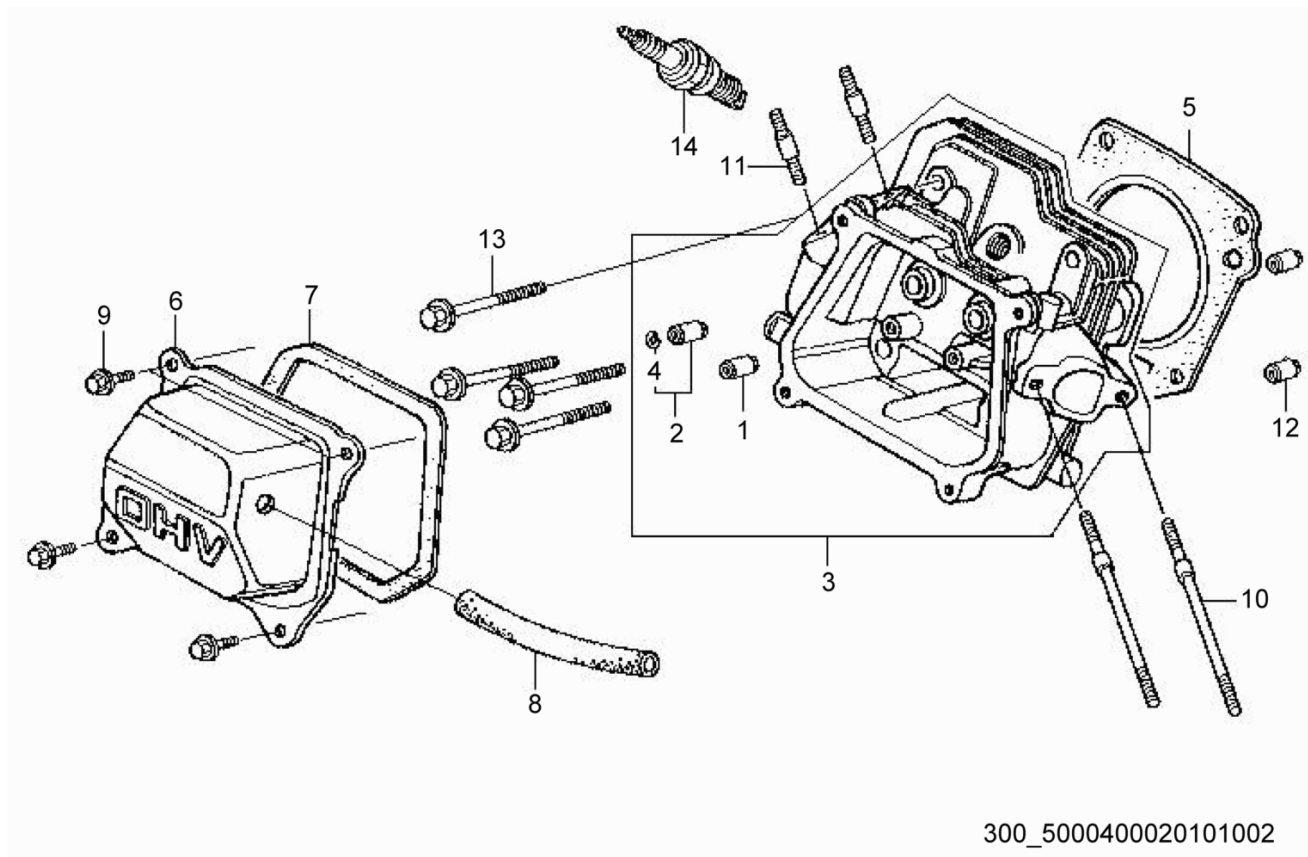

300_5000400020101002

Ref. Pos.	Part No. Artikel Nr.	Qty. St.	Description Beschreibung	Descripción Description	Measurement/Abm.	Norm
					Torque/Drehm.	Sealant Schmierstoff
1	0070945	1	Valve guide Ventilführung	Guíaválvula Guide de soupape		
2	0070944	1	Valve guide Ventilführung	Guíaválvula Guide de soupape		
3	0081786	1	Cylinder head Zylinderkopf	Culata Culasse		
4	0081744	1	Valve guide clip Sicherungsring	Sujetador Agrafe		
5	0216514	1	Cylinder head gasket Zylinderkopfdichtung	Junta de culata del cilindro Joint de culasse de cylindre		
6	0406654	1	Cylinder head cover Zylinderkopfhaube	Tapa del cilindro Couvercle supérieur		
7	0070942	1	Gasket Dichtung	Junta Joint		
8	0081761	1	Breather tube Entlüftungsrohr	Tubo respiradero Tube reniflard		
9	0053990	4	Flange bolt Flanschbolzen	Perno de reborde Boulon à bride	M6 x 12 10Nm/7ft.lbs	
10	0406696	2	Stud Gewindebolzen	Perno prisionero Goujon		
11	0070948	2	Stud Gewindebolzen	Perno prisionero Goujon	M8 x 32	
12	0070950	2	Dowel pin Paßstift	Espiga Cheville		
13	0406697	4	Flange bolt Flanschbolzen	Perno de reborde Boulon à bride		
14	0150914	1	Spark plug Zündkerze	Bujía Bougie d'allumage		

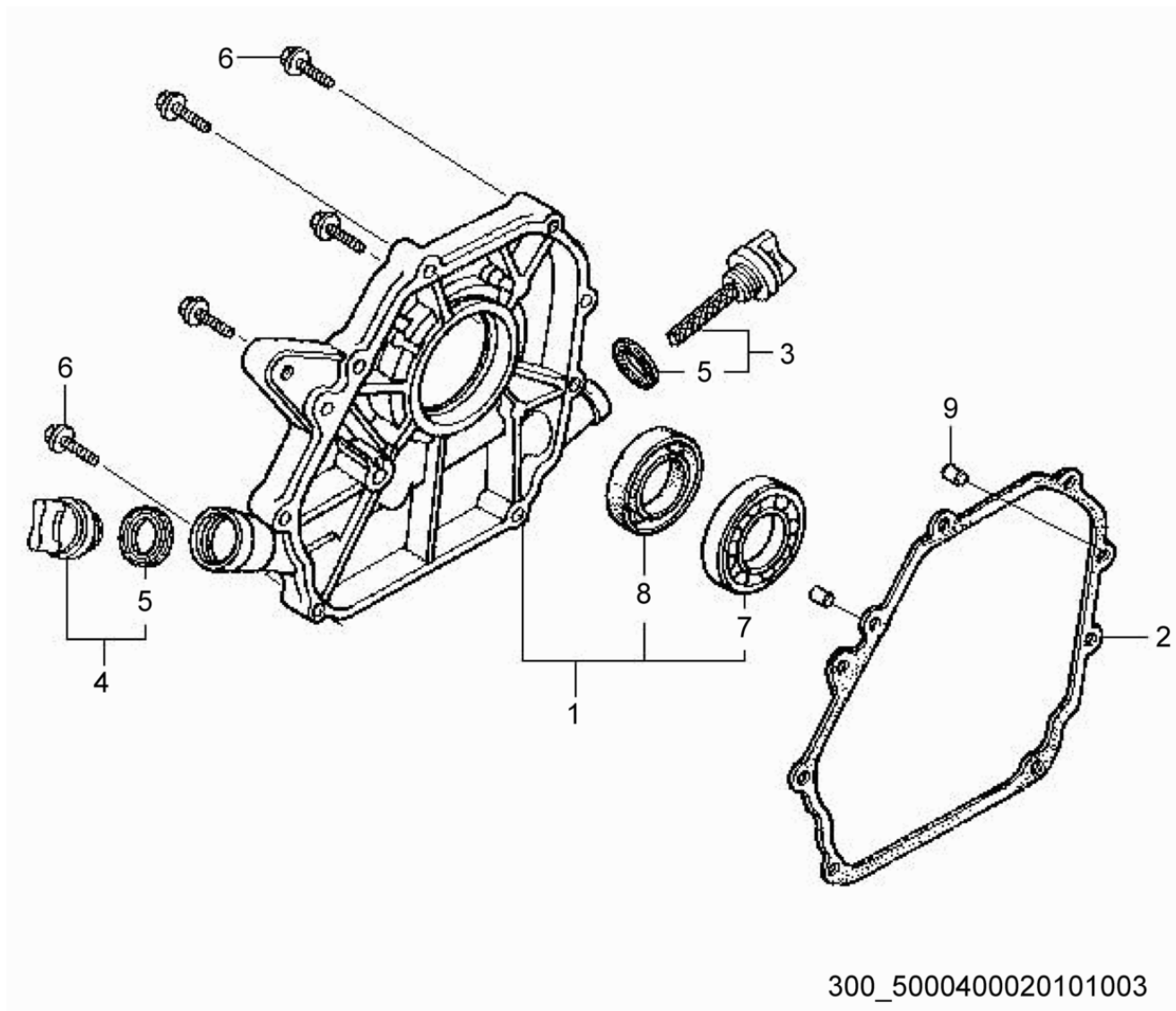

300_5000400020101003

Ref. Pos.	Part No. Artikel Nr.	Qty. St.	Description Beschreibung	Descripción Description	Measurement/Abm.	Norm
					Torque/Drehm.	Sealant Schmierstoff
1	0209788	1	Crankcase cover Kurbelgehäusedeckel	Tapa del cárter Couvercle de carter		
2	0081783	1	Gasket Dichtung	Junta Joint		
3	0162645	1	Dipstick cpl. Peilstab kpl.	Indicador del nivel de aceitecompl. Réglette-jauge compl.		
4	0162646	1	Oil filler cap Kappe-Ölfüller	Llenador de aceite Remplisseur d'huile		
5	0162647	2	Oil filler gasket Dichtung-Ölfüller	Junta de aceite Joint d'huile		
6	0070966	7	Flange bolt Flanschbolzen	Perno de reborde Boulon à bride	M6 x 28 10Nm/7ft.lbs	
7	0070961	1	Ball bearing Kugellager	Rodamiento de bolas Roulement à billes		
8	0070969	1	Shaft seal Wellendichtring	Sello del eje Bague d'étanchéité		
9	0053995	2	Dowel pin Paßstift	Espiga Cheville	A8 x 14	

Camshaft
Nockenwelle
Arbol de levas
Arbre à cames

VP 1135AW

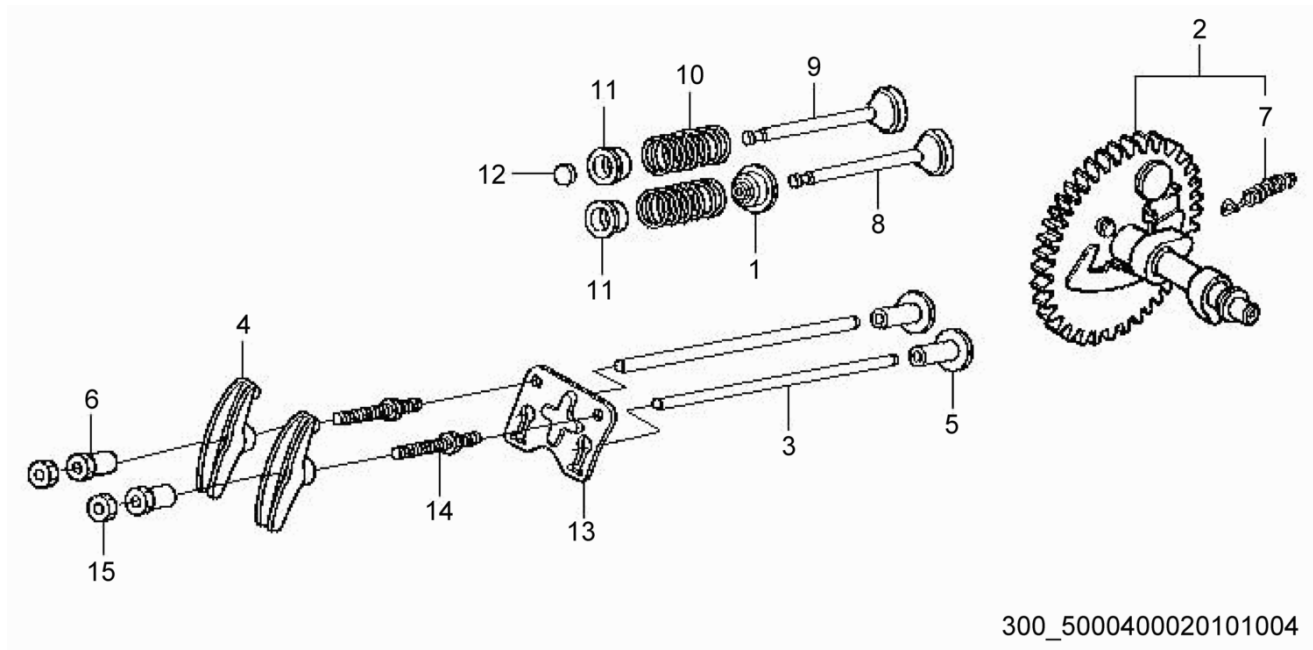

Ref. Pos.	Part No. Artikel Nr.	Qty. St.	Description Beschreibung	Descripción Description	Measurem./Abm.	Norm
					Torque/Drehm.	Sealant Schmierstoff
1	0406681	1	Seal-valve stem Dichtung-Ventilspindel	Junta-husillo de válvula Joint-tige de soupape		
2	0072902	1	Camshaft Nockenwelle	Arbol de levas Arbre à cames		
3	0070989	2	Push rod (valve lifter) Stoßstange	Levantaválvula Poussoir de soupape		
4	0070986	2	Rocker arm Kipphebel	Balancín Culbuteur		
5	0070990	2	Valve tappet Ventilstößel	Levantaválvula Poussoir		
6	0070985	2	Rocker arm pivot Einstellmutter	Espaciador Pivot		
7	0151028	1	Spring Feder	Resorte Ressort		
8	0406703	1	Intake valve Einlaßventil	Válvula de admisión Soupape d'admission		
9	0406704	1	Exhaust valve Auslaßventil	Válvula de escape Soupape d'échappement		
10	0081760	2	Spring Feder	Resorte Ressort		
11	0070996	2	Holder Halter	Soporte Attache		
12	0070998	1	Rotator valve cap Ventilkappe	Tapa-válvula Couvercle de soupape		
13	0070988	1	Plate Platte	Placa Plaque		
14	0072778	1	Stud Gewindebolzen	Perno prisionero Goujon	8M	
15	0070984	2	Nut Mutter	Tuerca Écrou	1/4-28in	

Fuel Tank cpl.
Kraftstofftank kpl.

VP 1135AW

Depósito de Combustible compl.
Réservoir de carburant compl.

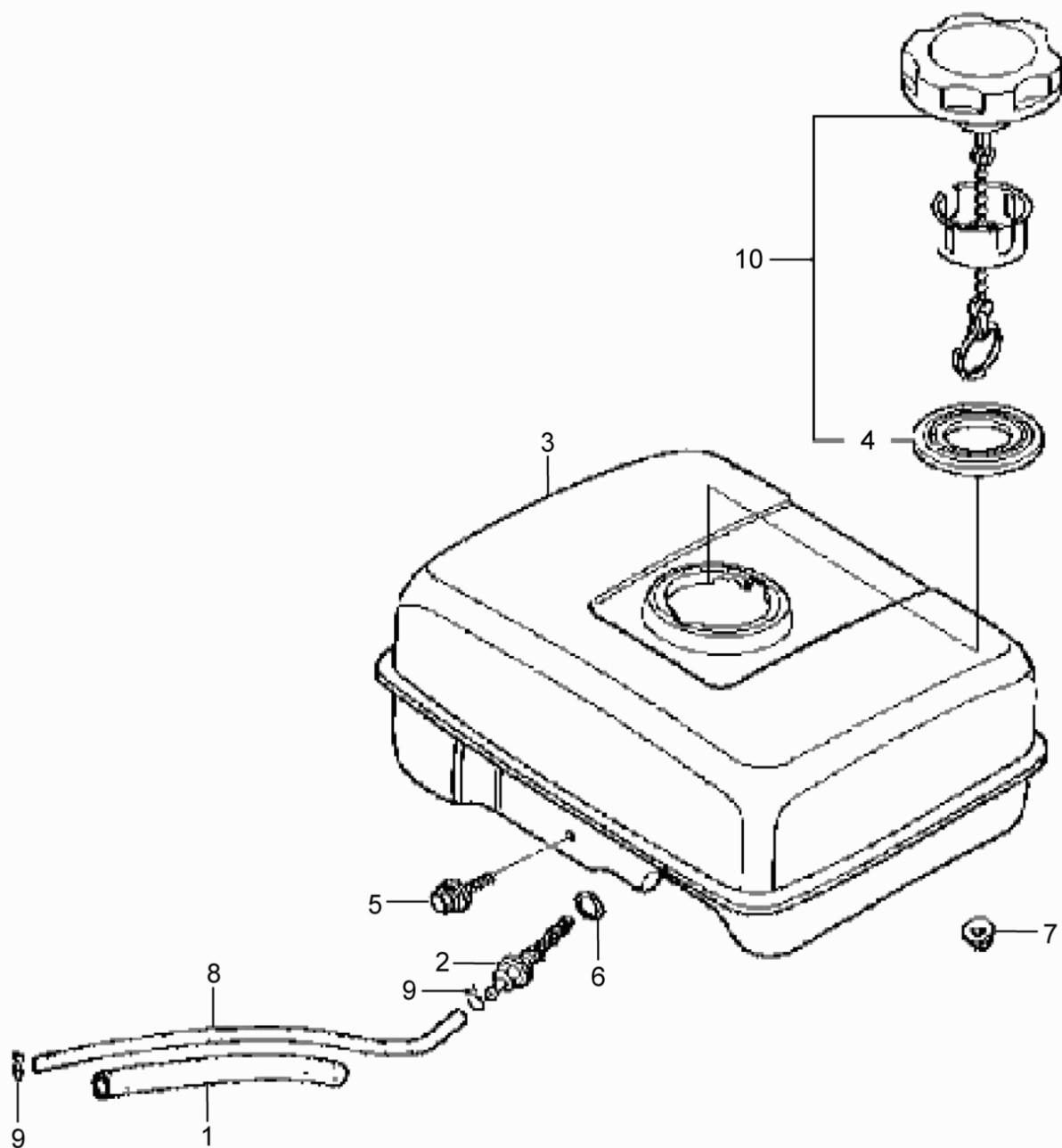

300_5000400020101005

Ref. Pos.	Part No. Artikel Nr.	Qty. St.	Description Beschreibung	Descripción Description	Measurement./Abm.	Norm
					Torque/Drehm.	Sealant Schmierstoff
1	0081764	1	Protective hose Schutzschlauch	Manguera Tuyau		
2	0406691	1	Fuel filter Kraftstofffilter	Filtro de combustible Filtre à carburant		
3	0406692	1	Fuel tank Kraftstofftank	Depósito de combustible Réservoir de carburant		
4	0209770	1	Gasket Dichtung	Junta Joint		
5	0209771	1	Flange bolt Flanschbolzen	Perno de reborde Boulon à bride	6 x 29	
6	0071082	1	O-Ring O-Ring	Anillo-O Joint torique	14 x 1,3	
7	0071056	2	Nut Mutter	Tuerca Écrou	M6	
8	0406695	1	Fuel hose Kraftstoffleitung	Manguera de combustible Tuyau de carburant		
9	0054136	2	Hose clamp Schlauchselle	Abrazaderas de manguera Agrafe de tuyau		
10	0217460	1	Fuel tank cap Tankverschluß	Tapa del tanque Chapeau de réservoir		

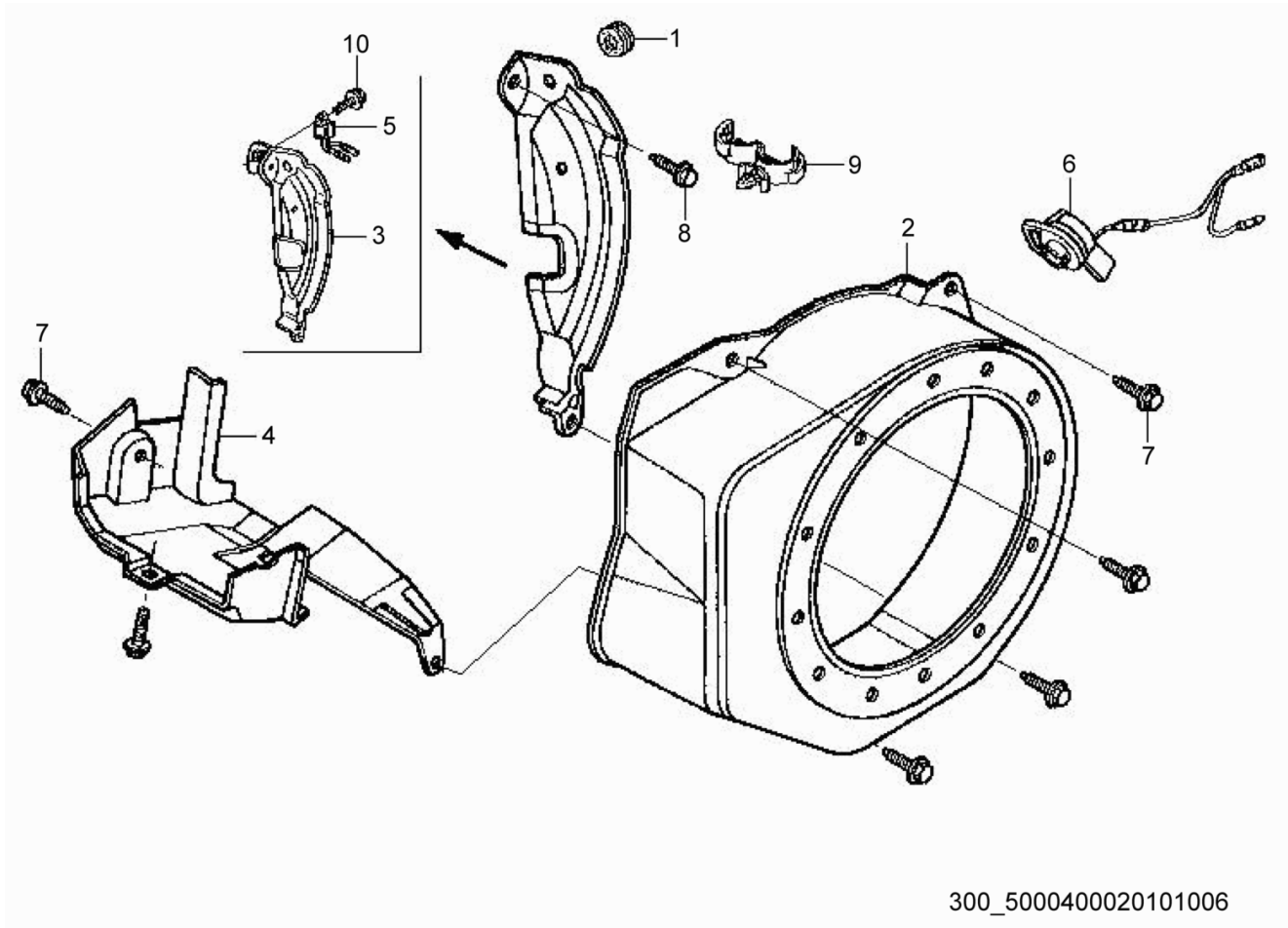

Ref. Pos.	Part No. Artikel Nr.	Qty. St.	Description Beschreibung	Descripción Description	Measurement./Abm.	Norm
					Torque/Drehm.	Sealant Schmierstoff
1	0070979	1	Grommet Tülle	Ojal Passe-fil	0,315in	
2	0406687	1	Fan Cover Gebläsedeckel	Tapa del Ventilador Couvercle du Ventilateur		
3	0153137	1	Plate Platte	Placa Plaque		
4	0153139	1	Duct Luftleitblech	Conducto de aire Canal d'air		
5	0125834	1	Electronic filter Elektronischer Filter	Filtro electrónico Filtre électronique		
6	0162682	1	Switch cpl. Schalter kpl.	Interruptor compl. Interrupteur compl.		
7	0053990	6	Flange bolt Flanschbolzen	Perno de reborde Boulon à bride	M6 x 12 10Nm/7ft.lbs	
8	0071055	1	Hexagonal flange head screw Sechskantflanschschraube	Tornillo hexagonal de brida Vis hexagonale de bride	M6 x 20 10Nm/7ft.lbs	
9	0151700	1	Clip Befestigung	Clip Clip		
10	0081750	1	Screw Schraube	Tornillo Vis	M6 x 8	

Starter cpl.
Starter kpl.
Arrancador compl.
Démarrreur compl.

VP 1135AW

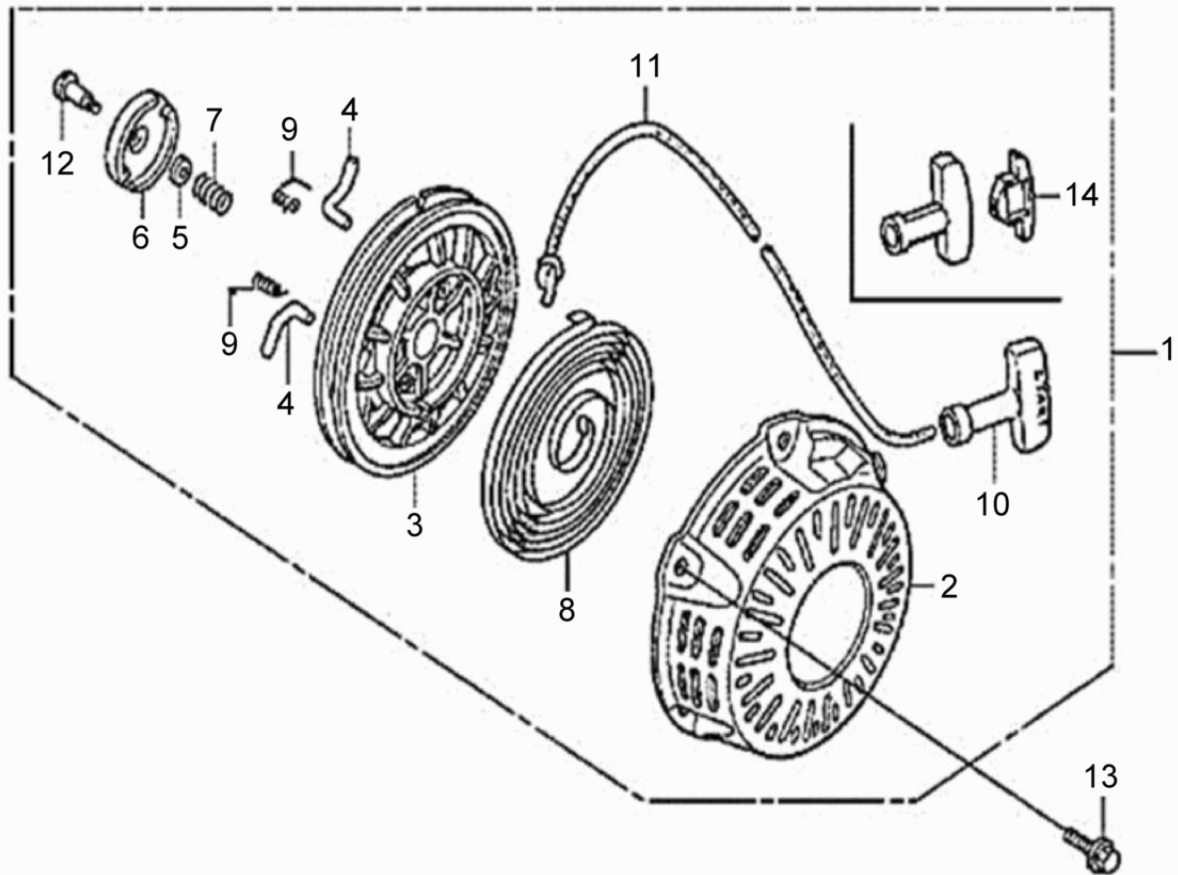

300_5000400020101007

Ref. Pos.	Part No. Artikel Nr.	Qty. St.	Description Beschreibung	Descripción Description	Measurem./Abm.	Norm
					Torque/Drehm.	Sealant Schmierstoff
1	0406625	1	Recoil starter cpl. Reversierstarter kpl.	Arrancador compl. Démarrreur compl.		
2	0406626	1	Starter housing Startergehäuse	Caja del arrancador Carter de démarrage		
3	0406627	1	Starter reel Seilscheibe	Disco de cuerda Disque pour corde		
4	0160527	2	Ratchet (pawl) Ratsche	Trinquete Cliquet		
5	0160748	1	Friction plate Reibplatte	Placa fricción Plaque de friction		
6	0160745	1	Ratchet guide Führung	Guía Ancre		
7	0160747	1	Spring-friction Reibfeder	Resorte de fricción Ressort de friction		
8	0081777	1	Spring Feder	Resorte Ressort		
9	0207990	2	Return spring Ausdrückbolzenfeder	Resorte retractor Ressort de rappel		
10	0406628	1	Knob Griff	Empuñadura Poignée		
11	0081781	1	Rope Seil	Cuerda Corde		
12	0207991	1	Screw Schraube	Tornillo Vis		
13	0158458	3	Flange bolt Flanschbolzen	Perno de reborde Boulon à bride	6 x 10	
14	0406629	1	Knob Griff	Empuñadura Poignée		

Carburetor cpl.
Vergaser kpl.
Carburador compl.
Carburateur compl.

VP 1135AW

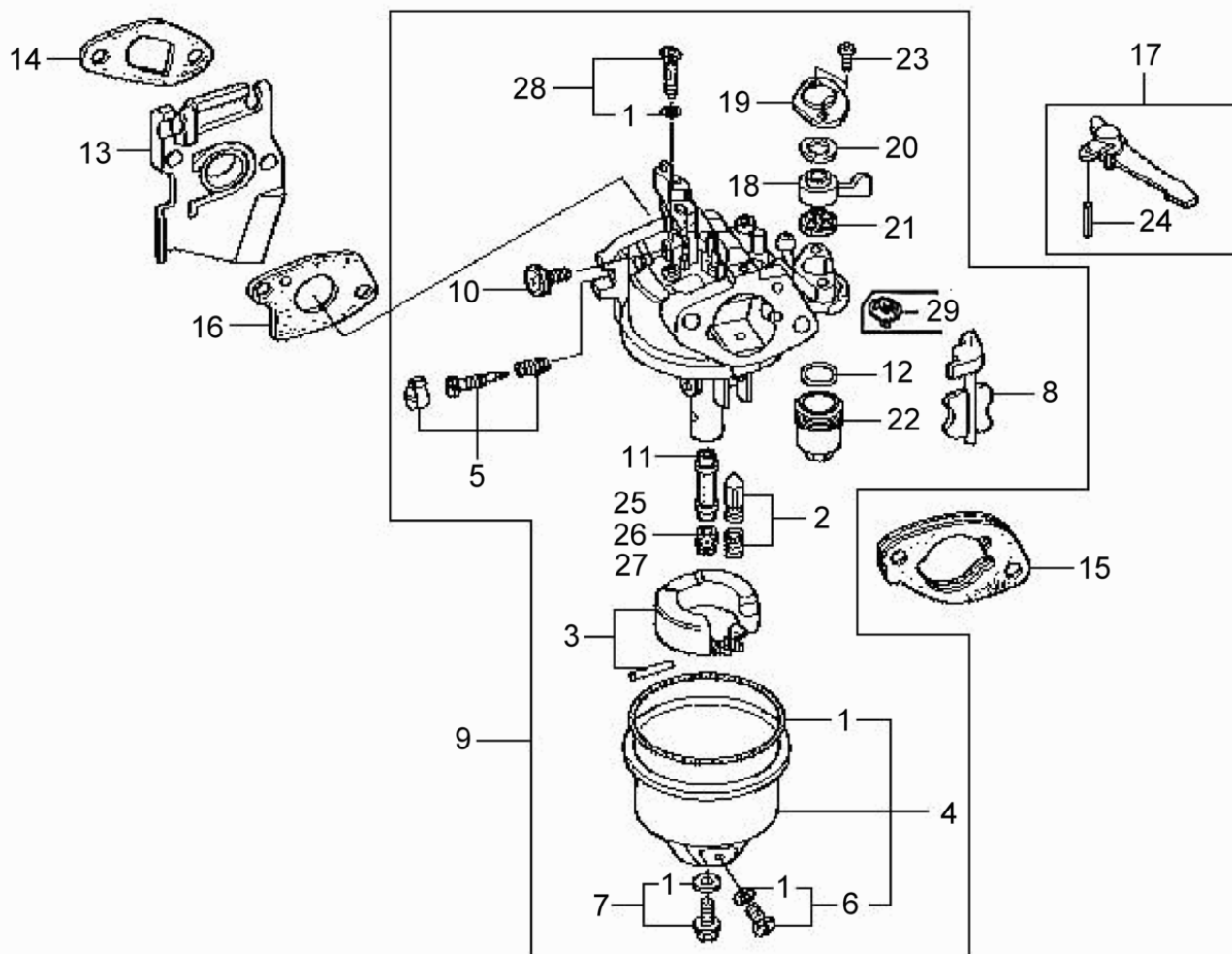

300_5000400020101008

Ref. Pos.	Part No. Artikel Nr.	Qty. St.	Description Beschreibung	Descripción Description	Measurem./Abm.	Norm
					Torque/Drehm.	Sealant Schmierstoff
1	0072781	1	Gasket Set Dichtungssatz	Juego de juntas Jeu de joints		
2	0071022	1	Float Valve Set Schwimmernadel kpl.	Válvula de flotador compl. Pointeau du carburateur compl.		
3	0209764	1	Float Schwimmer	Flotador Flotteur		
4	0406633	1	Carburetor Float Set Schwimmersatz	Juego de flotador Jeu de flotteur		
5	0089286	1	Setscrew Gewindestift	Tornillo Vis		
6	0406634	1	Screw w/washer Schraube mit Scheibe	Tornillo con arandela Vis avec rondelle		
7	0406635	1	Screw w/washer Schraube mit Scheibe	Tornillo con arandela Vis avec rondelle		
8	0071025	1	Engine Choke Set Chokesatz	Juego de estrangulador Jeu d'étrangleur		
9	0406688	1	Carburetor cpl. Vergaser kpl.	Carburador compl. Carbureteur compl.		
10	0071018	1	Throttle stop screw Anschlagschraube	Tornillo de tope Vis		
11	0089355	1	Main jet Hauptdüse	Chicler principal Gicleur principal		
12	0071024	1	Gasket Dichtung	Junta Joint		
13	0071010	1	Insulator Isolator	Aislador Isolant		
14	0081794	1	Gasket Dichtung	Junta Joint		
15	0071015	1	Spacer Abstandsstück	Espaciador Entretoise		
16	0081762	1	Gasket Dichtung	Junta Joint		
17	0071013	1	Choke control lever Chokehebel	Palanca estranguladora Levier d'étrangleur		
18	0150266	1	Fuel valve lever Kraftstoffhahn	Palanca Levier		
19	0073269	1	Plate Platte	Placa Plaque		
20	0073270	1	Spring Feder	Resorte Ressort		
21	0073272	1	Gasket Dichtung	Junta Joint		
22	0071023	1	Fuel filter Kraftstofffilter	Filtro de combustible Filtre à carburant		
23	0156674	2	Screw Schraube	Tornillo Vis	M3 x 6	
24	0071014	1	Pin Stift	Pasador Goupille	2 x 12	
25	0153140	1	Main jet Hauptdüse	Chicler principal Gicleur principal	55	

Carburetor cpl.
Vergaser kpl.
Carburador compl.
Carburateur compl.

VP 1135AW

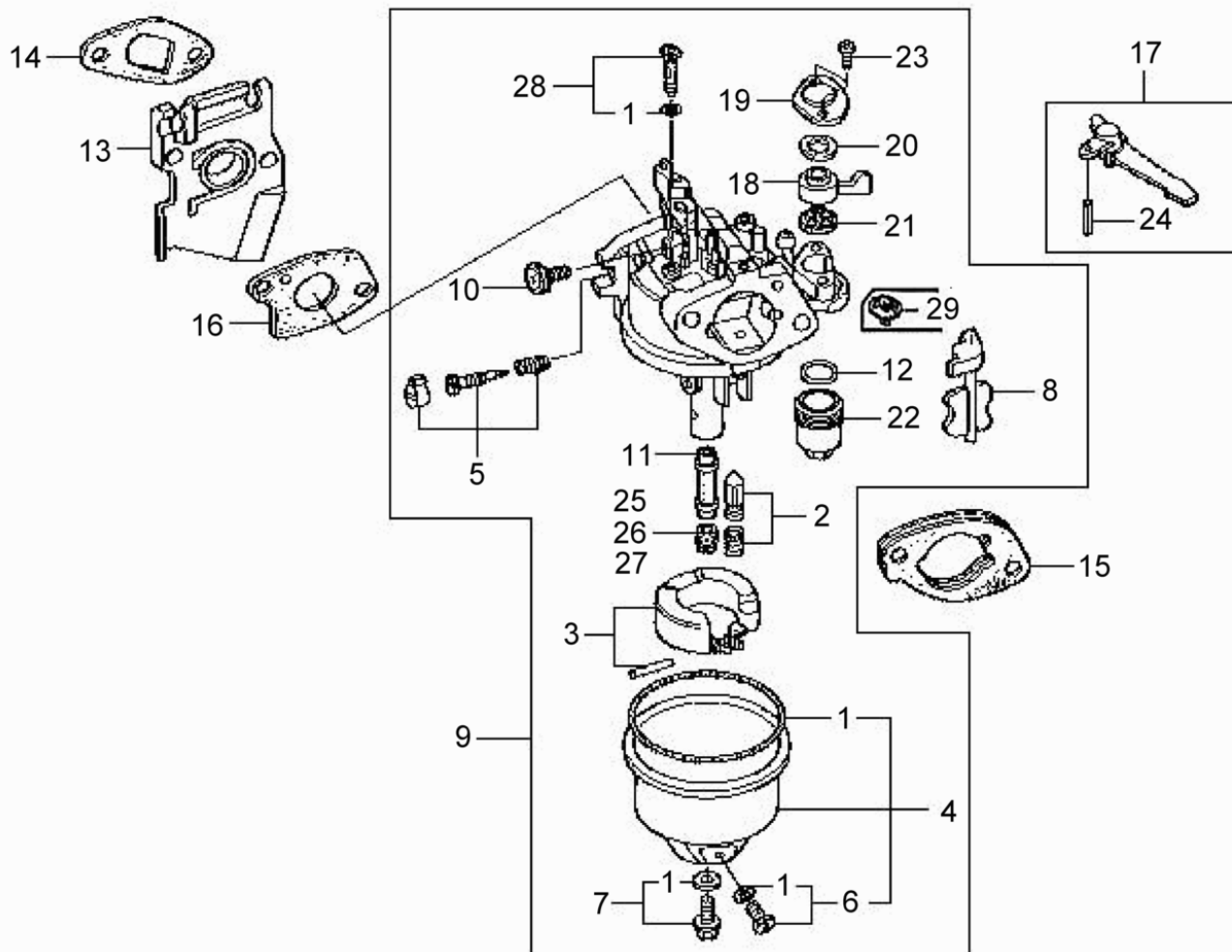

300_5000400020101008

Ref. Pos.	Part No. Artikel Nr.	Qty. St.	Description Beschreibung	Descripción Description	Measurem./Abm.	Norm
					Torque/Drehm.	Sealant Schmierstoff
26	0153141	1	Main jet Hauptdüse	Chicler principal Gicleur principal	58	
27	0153142	1	Main jet Hauptdüse	Chicler principal Gicleur principal	60	
28	0071016	1	Pilot jet Leerlaufdüse	Chicler ralenti Gicleur de ralenti	35	
29	0406640	1	Filter Filter	Filtro Filtre		

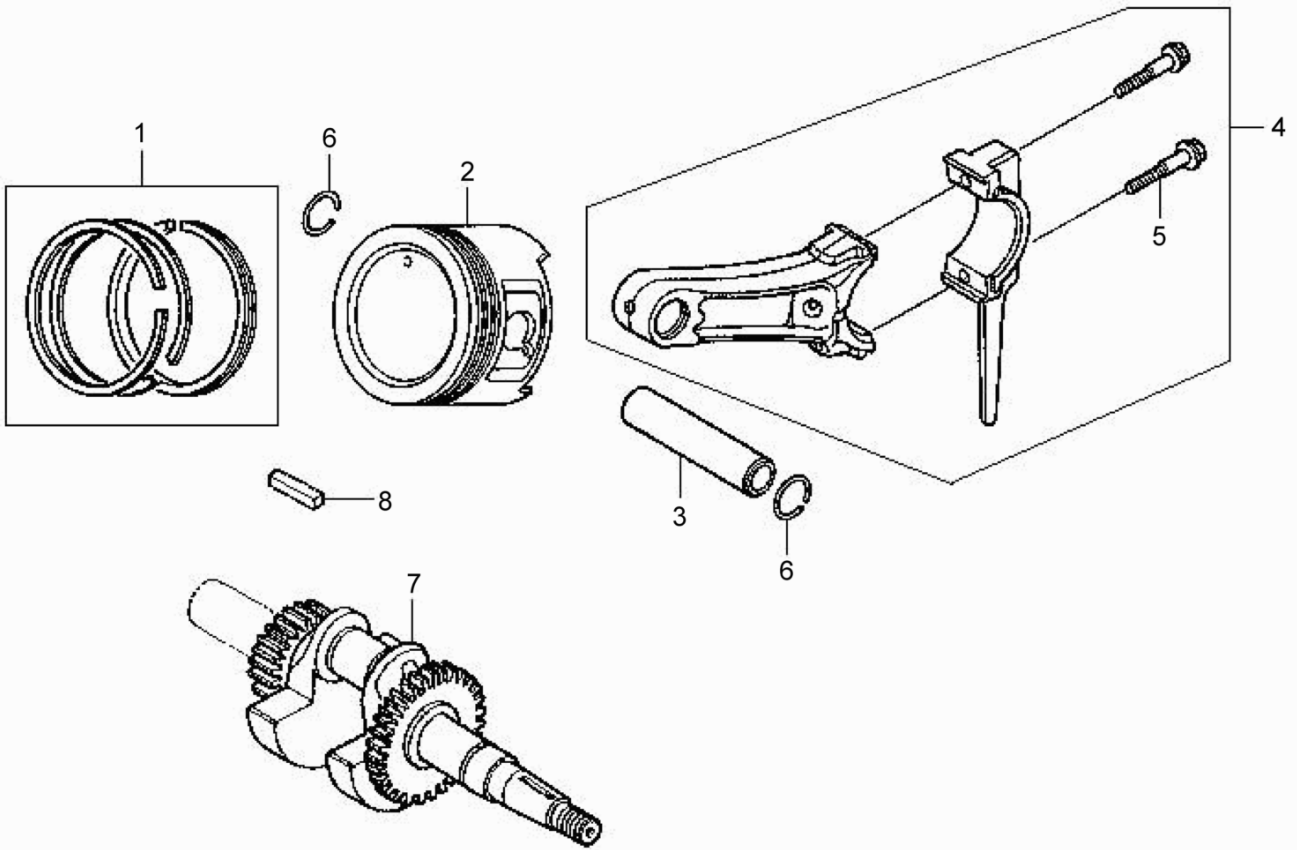

300_5000400020101009

Ref. Pos.	Part No. Artikel Nr.	Qty. St.	Description Beschreibung	Descripción Description	Measurement./Abm.	Norm
					Torque/Drehm.	Sealant Schmierstoff
1	0213401	1	Piston w/Ring Set Satz-Kolben mit Kolbenringen	Juego-pistón con aros Jeu-piston avec segments		
2	0213405	1	Piston Kolben	Pistón Piston		
3	0071008	1	Piston pin Kolbenbolzen	Pasador de pistón Axe de piston		
4	0209799	1	Connecting rod Pleuel	Biela Bielle		
5	0071007	2	Screw Schraube	Tornillo Vis	M7 x 35	
6	0081751	2	Piston pin clip Bolzensicherung	Seguro perno de pistón Anneau de fixation		
7	0209790	1	Crankshaft Kurbelwelle	Cigüeñal Vilebrequin		
8	0151053	1	Square key Passfeder	Chaveta Clavette	5 x 5 x 33	

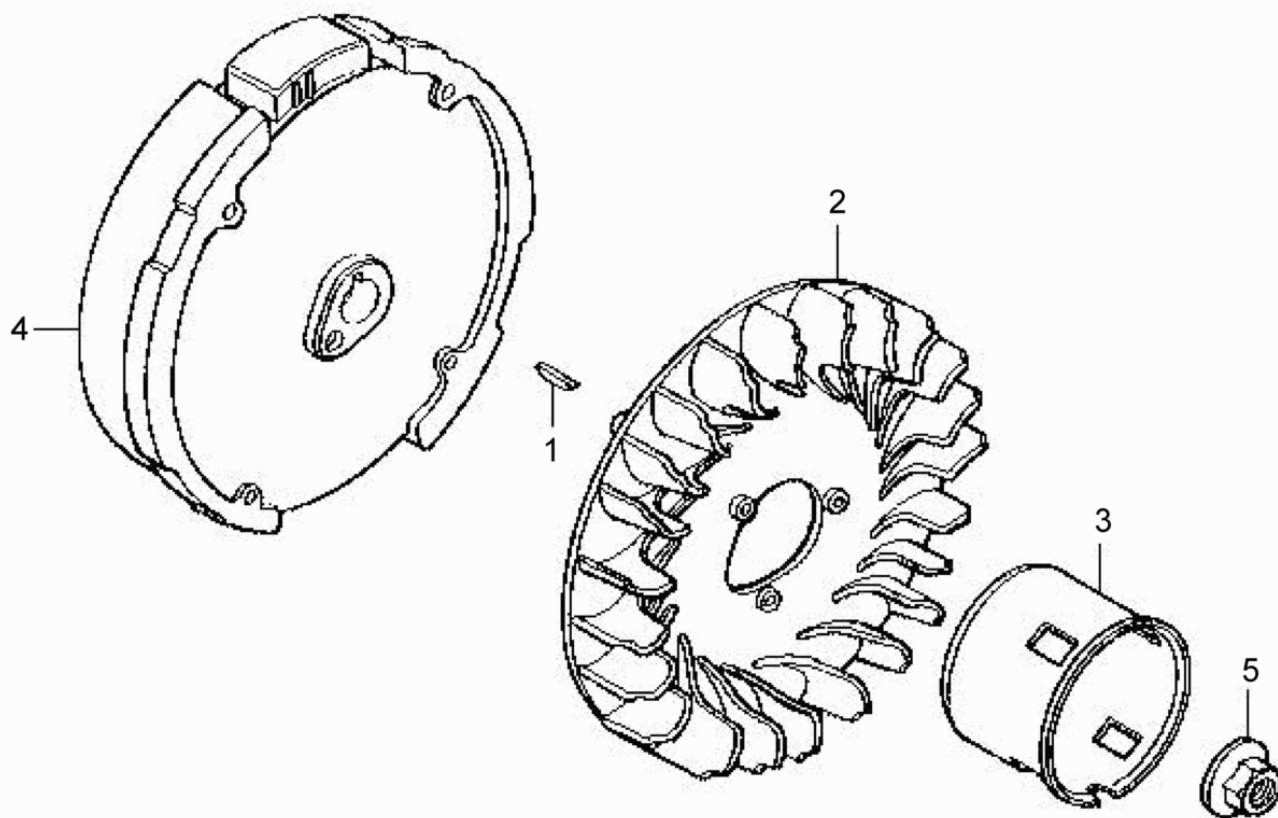

300_5000400020101010

Ref. Pos.	Part No. Artikel Nr.	Qty. St.	Description Beschreibung	Descripción Description	Measurem./Abm.	Norm
					Torque/Drehm.	Sealant Schmierstoff
1	0068967	1	Woodruff key Woodruffkeil	Chaveta Woodruff Clavette Woodruff	25 x 18	
2	0070976	1	Fan Gebläserad	Ventilador Ventilateur		
3	0160750	1	Starter pulley Starterscheibe	Polea Poulie de démarrage		
4	0213410	1	Flywheel Schwungrad	Volante Volant		
5	0162686	1	Nut Mutter	Tuerca Écrou	M14	

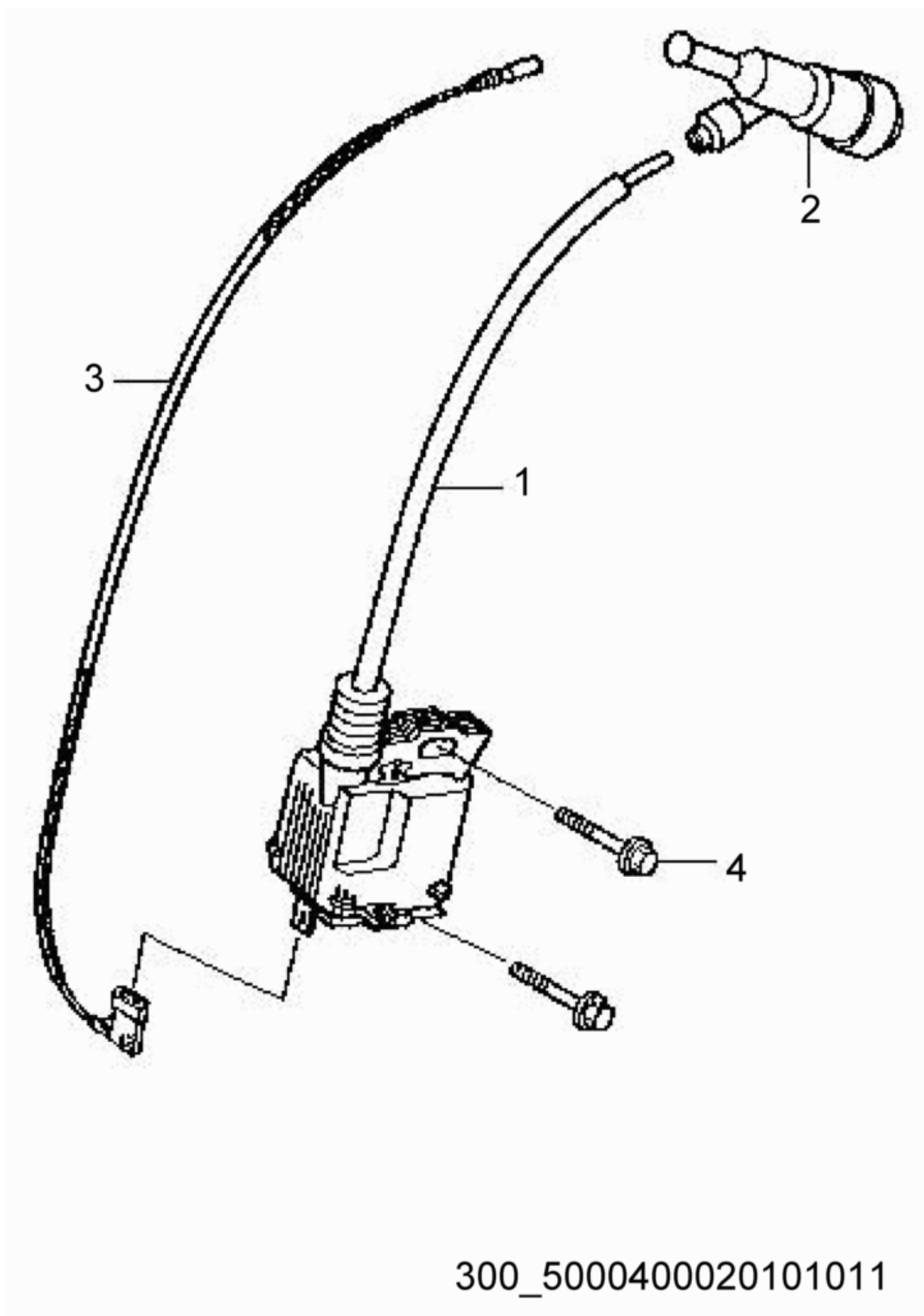

Ref. Pos.	Part No. Artikel Nr.	Qty. St.	Description Beschreibung	Descripción Description	Measurem./Abm.	Norm
					Torque/Drehm.	Sealant Schmierstoff
1	0162679	1	Ignition coil Zündspule	Bobina de encendido Bobine d'allumage		
2	0162680	1	Spark plug cap Zündkerzenstecker	Capuchón de bujía Capuchon de bougie		
3	0081663	1	Wire Kabel	Alambre Fil		
4	0081737	2	Screw Schraube	Tornillo Vis	M6 x 25	

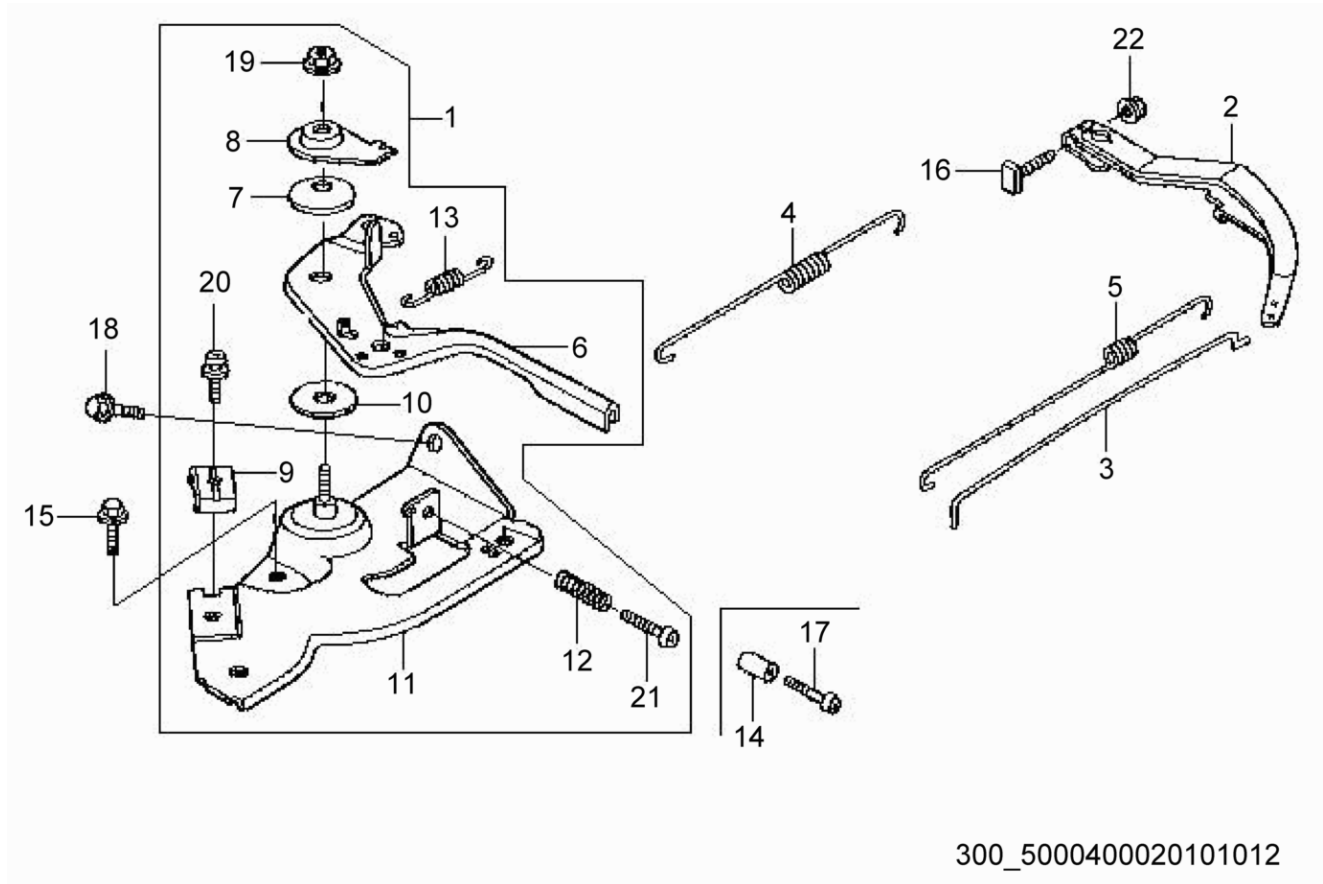

300_5000400020101012

Ref. Pos.	Part No. Artikel Nr.	Qty. St.	Description Beschreibung	Descripción Description	Measurem./Abm.	Norm
					Torque/Drehm.	Sealant Schmierstoff
1	0406698	1	Control cpl. Betätigung kpl.	Regulador compl. Commande compl.		
2	0081742	1	Governor lever Reglerhebel	Palanca del gobernador Levier régulateur		
3	0071068	1	Governor rod Reglerstange	Varilla Tringle		
4	0081070	1	Governor spring Reglerfeder	Resorte del regulador Ressort régulateur		
5	0081743	1	Spring Feder	Resorte Ressort		
6	0406699	1	Lever Hebel	Palanca Levier		
7	0071058	1	Spring washer Tellerfeder	Arandela de resorte Ressort Belleville		
8	0071057	1	Washer Scheibe	Arandela Rondelle		
9	0071062	1	Cable holder Kabelhalter	Soporte cable Attache		
10	0071064	1	Spacer Abstandsstück	Espaciador Entretoise		
11	0406700	1	Mount Konsole	Ménsula Support		
12	0054088	1	Adjusting spring Justierfeder	Resorte de ajuste Ressort d'ajustage		
13	0071667	1	Spring Feder	Resorte Ressort		
14	0156684	1	Spacer Abstandsstück	Espaciador Entretoise		
15	0053990	1	Flange bolt Flanschbolzen	Perno de reborde Boulon à bride	M6 x 12 10Nm/7ft.lbs	
16	0068966	1	Bolt Bolzen	Perno Boulon		
17	0156685	1	Screw Schraube	Tornillo Vis	M5 x 25	
18	0071055	1	Hexagonal flange head screw Sechskantflanschschraube	Tornillo hexagonal de brida Vis hexagonale de bride	M6 x 20 10Nm/7ft.lbs	
19	0072782	1	Lock nut Sicherungsmutter	Contratuerca Contre-écrou	M6	
20	0110112	1	Screw Schraube	Tornillo Vis	5 x 16	
21	0081990	1	Screw Schraube	Tornillo Vis	M5 x 25	
22	0071056	1	Nut Mutter	Tuerca Écrou	M6	

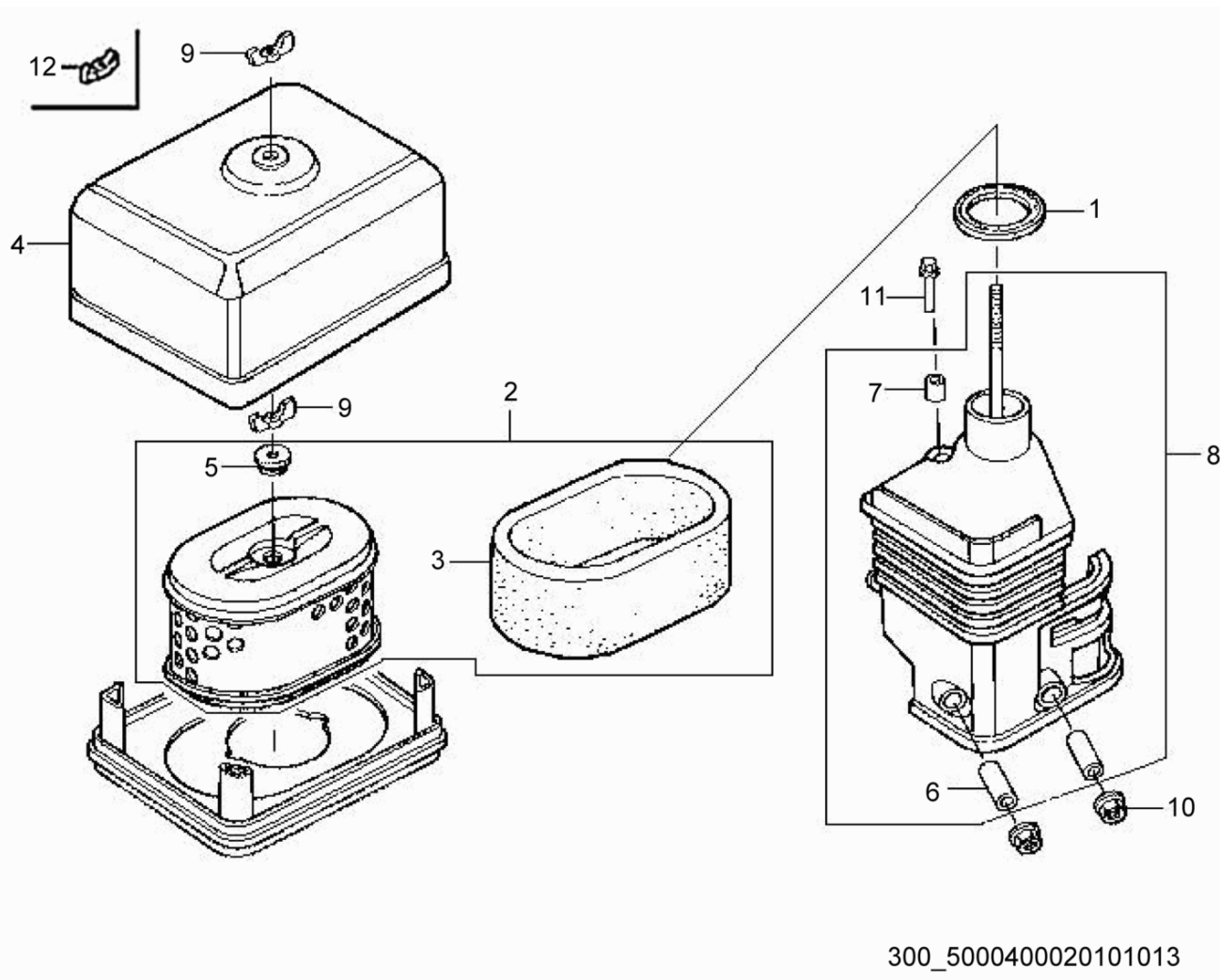

300_5000400020101013

Ref. Pos.	Part No. Artikel Nr.	Qty. St.	Description Beschreibung	Descripción Description	Measurem./Abm.	Norm
					Torque/Drehm.	Sealant Schmierstoff
1	0071032	1	Gasket Dichtung	Junta Joint		
2	0072314	1	Air cleaner element Filtereinsatz	Elemento-filtro Filtre à air seul		
3	0076941	1	Prefilter element Vorfilterelement	Elemento del prefiltro Élément du prénettoyeur		
4	0406689	1	Cover Deckel	Tapa Couvercle		
5	0072343	1	Grommet Tülle	Ojal Passe-fil		
6	0081746	2	Sleeve Hülse	Manguito Douille		
7	0071035	1	Sleeve Hülse	Manguito Douille		
8	0406690	1	Elbow cpl. Krümmer kpl.	Codo compl. Coude compl.		
9	0071621	2	Wing nut Flügelmutter	Tuerca de mariposa Écrou à oreilles	M6	
10	0071056	2	Nut Mutter	Tuerca Écrou	M6	
11	0107064	1	Screw Schraube	Tornillo Vis	M6 x 20	
12	0406643	1	Wing nut Flügelmutter	Tuerca de mariposa Écrou à oreilles		

Muffler
Auspufftopf
Silenciador
Pot d'échappement

VP 1135AW

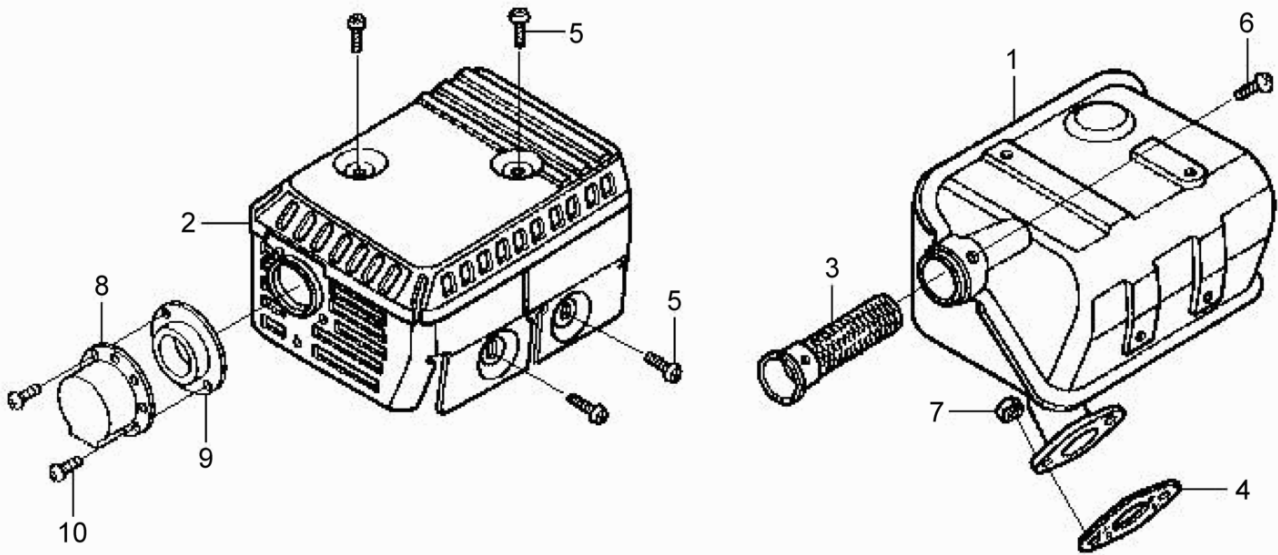

300_5000400020101014

Ref. Pos.	Part No. Artikel Nr.	Qty. St.	Description Beschreibung	Descripción Description	Measurement./Abm.	Norm
					Torque/Drehm.	Sealant Schmierstoff
1	0406644	1	Muffler Auspufftopf	Silenciador Pot d'échappement		
2	0406646	1	Guard Schutz	Protector Protection		
3	0071075	1	Spark arrester Funkenfänger	Parachispas Pare-étincelles		
4	0216516	1	Muffler gasket Auspufftopfdichtung	Junta del silenciador Joint du silencieux		
5	0071070	4	Screw Schraube	Tornillo Vis	M5 x 8	
6	0150916	1	Screw Schraube	Tornillo Vis	4 x 6	
7	0071076	2	Nut Mutter	Tuerca Écrou	M8	
8	0081756	1	Exhaust baffle Aufpuffleitblech	Deflector de escape Déflecteur d'échappement		
9	0081757	1	Guide Führung	Guía Guide		
10	0209783	2	Self-tapping screw Schneidschraube	Tornillo autorroscante Vis autotaraudeuse	4 x 8	



**WACKER
NEUSON**

**Accessories
Sonderzubehör
Accesorios
Accessoires**

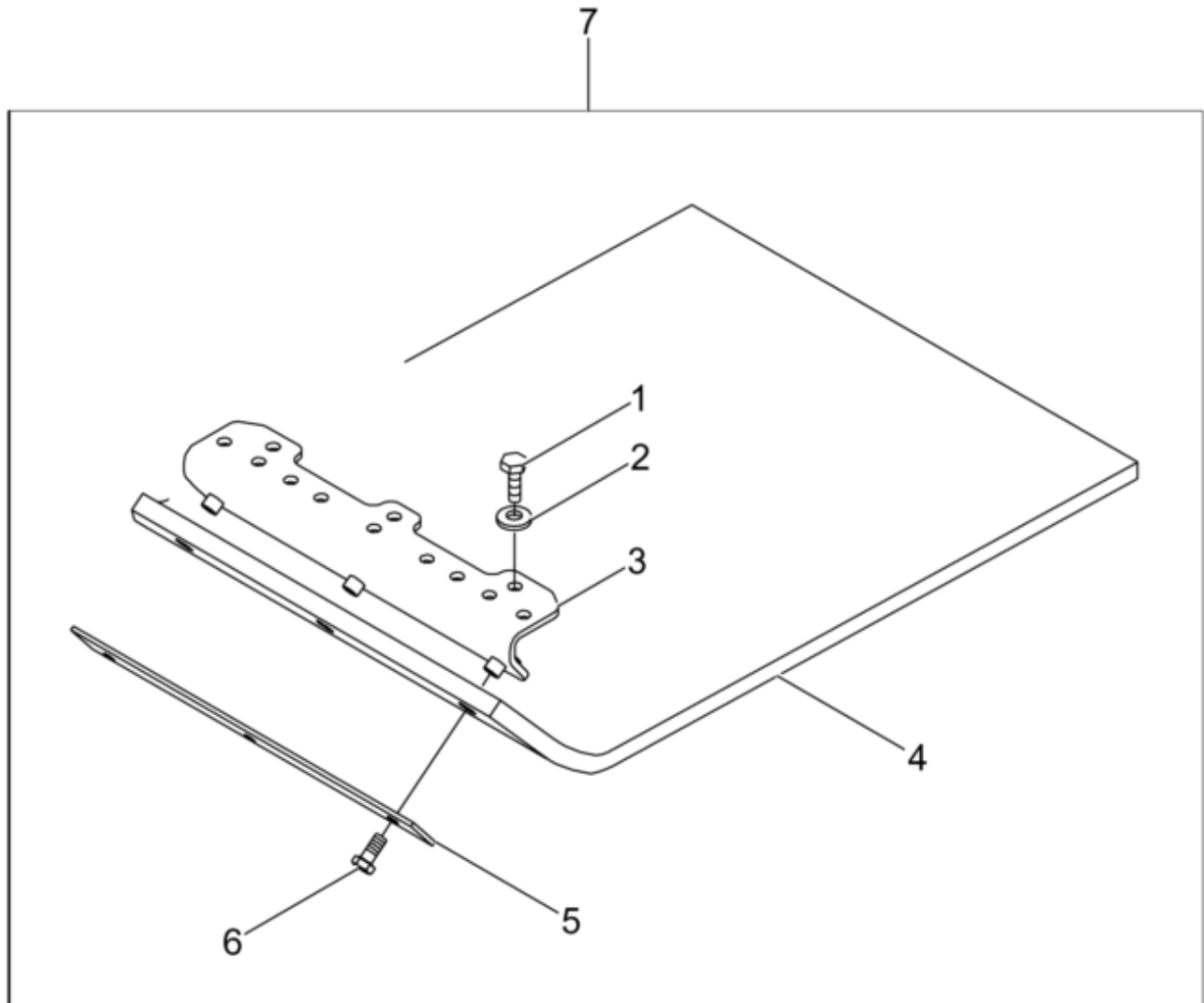

wc_ex0118674001

Ref. Pos.	Part No. Artikel Nr.	Qty. St.	Description Beschreibung	Descripción Description	Measurem./Abm.	Norm
					Torque/Drehm.	Sealant Schmierstoff
1	0012362	3	Hexagonal head cap screw Sechskantschraube	Tornillo hexagonal Boulon à tête hexagonale	M8 x 20 20Nm/15ft.lbs	DIN 933 S3
2	0033198	3	Lock washer Federring	Federring Rondelle de ressort	B8	DIN 6796
3	0118671	1	Bracket Konsole	Soporte Support		
4	0112350	1	Paving stone pad Gleitplatte	Placa deslizante Dispositif à pavés	40cm	
5	0112349	1	Bracket Konsole	Soporte Support		
6	0011457	3	Hexagonal head cap screw Sechskantschraube	Tornillo hexagonal Boulon à tête hexagonale	M8 x 25 20Nm/15ft.lbs	DIN 933
7	0118674	1	Protective Pad Kit Plattengleitvorrichtung	Colchoneta para losas Dispositif à pavés	35/40cm	

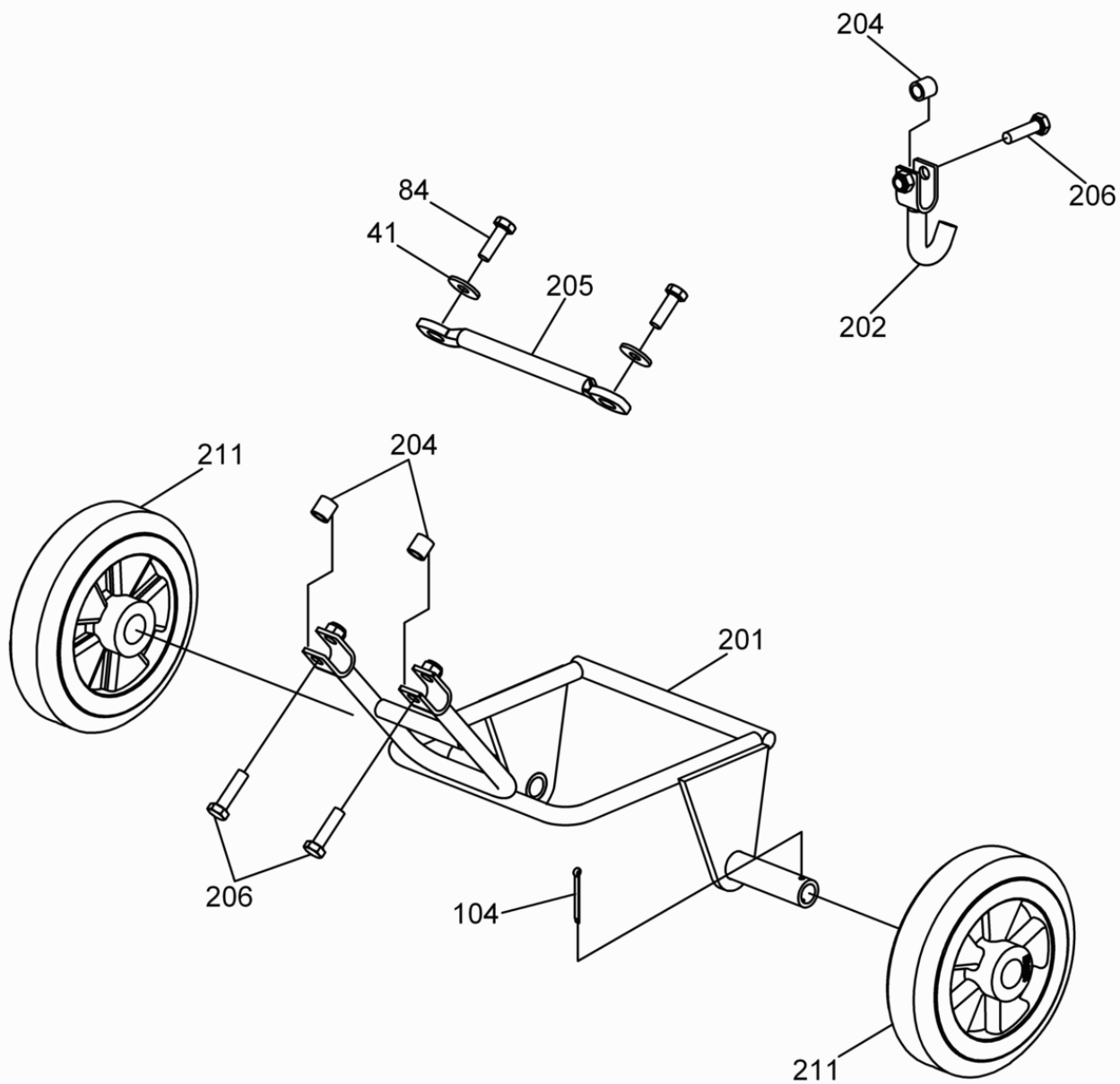

wpmex0630013100_04

Ref. Pos.	Part No. Artikel Nr.	Qty. St.	Description Beschreibung	Descripción Description	Measurement./Abm.	Norm
					Torque/Drehm.	Sealant Schmierstoff
41	0010374	2	Flat washer Scheibe	Arandela elástica Rondelle de ressort	B8,4	DIN 9021
84	0011457	2	Hexagonal head cap screw Sechskantschraube	Tornillo hexagonal Boulon à tête hexagonale	M8 x 25 25Nm/18ft.lbs	DIN 933
104	0130124	2	Cotter pin Sicherheitssplint	Clavija hendida Goupille fendue		
201	0130558	1	Weldment Schweißkonstruktion	Ensambladura soldada Construction soudée		
202	0130563	1	Hook Haken	Gancho Croc		
204	0130106	3	Bushing Buchse	Buje Douille		
205	0130568	1	Pivot Drehteil	Pivote Pivot		
206	0011456	3	Hexagonal head cap screw Sechskantschraube	Tornillo hexagonal Boulon à tête hexagonale	M8 x 30 25Nm/18ft.lbs	DIN 933
211	0130133	2	Wheel Rad	Rueda Roue		



**WACKER
NEUSON**