



**WACKER
NEUSON**

0620991	104
05.2012	

**Hydronic Surface Heaters
Hydronic Boden- und Flächenheizer
Calentadores de superficie hidrónicos
Réchauffeurs hydroniques par surface**

HSH 650

**Parts Book
Ersatzteile
Lista de Repuestos
Liste de Pièces de Rechange**

www.wackerneuson.com

A nameplate listing the Model Number, Item Number, Revision, and Serial Number is attached to each unit. Please record the information found on this plate so it will be available should the nameplate become lost or damaged. When ordering parts or requesting service information, you will always be asked to specify the model, item number, revision number, and serial number of the unit.

Ein Typenschild mit Typ, Artikelnummer, Version und Maschinen-Nummer ist an jedem Gerät angebracht. Die Daten von diesem Schild bitte notieren, damit sie auch bei Verlust oder Beschädigung des Schildes noch vorhanden sind. Der Typ, die Artikel-Nummer, die Versions- Nummer und die Maschinen-Nummer sind bei der Ersatzteilbestellung oder Nachfragen bezüglich Service-Informationen stets erforderlich.

Una placa de identificación con el modelo, número de referencia, nivel de revisión y número de serie ha sido añadida en cada máquina. Favor de anotar los datos en la placa en caso de que la placa de identificación sea destruida o perdida. En todos los pedidos para repuestos necesita siempre el modelo, el número de referencia, el nivel de revisión y el número de serie de la máquina en cuestión.

Une plaque signalétique mentionnant le modèle, le numéro de référence, le niveau de révision et le numéro de série est fixée sur chaque machine. Veuillez noter les informations relevées sur cette plaque de façon à ce qu'elles soient toujours disponibles si la plaque signalétique venait à être perdue ou endommagée. Lorsque vous commandez des pièces détachées ou vous sollicitez des informations après-vente, on vous demandera toujours de préciser le modèle, le numéro de référence, le niveau de révision et le numéro de série de la machine.

***My machine's numbers are / Die Nummern meines Gerätes sind /
Los números de mi máquina son / Les numéros de ma machine son :***



Part Numbers appearing in boldface type are recommended spare parts. This means that these parts are subject to wear under normal operating conditions and may require periodic service or replacement. It is recommended that these items be stocked to meet the expected service requirements of this model. Actual stocking quantities of these and other parts used in more extensive repairs will depend on the service practices of each customer.

Bei den in den Ersatzteillisten fettgedruckten Nummern handelt es sich um empfohlene Ersatzteile. Dies bedeutet, daß diese Teile bei normalen Anwendungsbedingungen natürlicher Abnutzung ausgesetzt sind und gelegentlich ersetzt oder überarbeitet werden müssen. Es wird geraten, diese Teile auf Lager bereit zu haben, um für Service-Arbeiten an diesem Gerät vorbereitet zu sein. Lagerbestände für diese und andere Teile, welche für ausgiebigere Reparaturarbeiten benötigt werden, können je nach Service-Gewohnheiten der einzelnen Kunden variieren.

Los números de partes en negritas en las Listas Ilustradas de Partes son los repuestos recomendados, ésto quiere decir que estas partes se desgastarán bajo circunstancias de funcionamiento normales y pueden requerir servicio periódico o su reemplazo. Se recomienda que el cliente mantenga un abastecimiento adecuado de estas partes para poder satisfacer la demanda requerida por el servicio a la máquina. La cantidad de repuestos que el cliente necesitará para reparaciones dependerá de la póliza de servicio de cada cliente.

Les numéros de pièces imprimés en caractères gras dans les Listes des Pièces Détachées de ce manuel sont les pièces détachées recommandées par la Wacker. Cela veut dire que ces pièces sont sujettes à usure dans des conditions de travail normales et peuvent nécessiter de l'entretien ou leur remplacement. Nous recommandons que vous disposez d'un stock de ces pièces pour pouvoir satisfaire la demande d'entretien de cette machine. Le client doit décider lui-même de la quantité exacte de pièces de rechange qu'il disposera dans ses stocks.

Generator Mount cpl. Teile für Montage des Generators Piezas para Montaje del Generador Pièces pour Montage du Générateur	10
Doors cpl. Türen kpl. Puertas Portes	14
Frame cpl. Rahmen kpl. Armazón compl. Châssis compl.	18
Covers cpl. Abdeckungen, kpl. Tapas compl. Capots cpl.	22
Fuel Tank cpl. Kraftstofftank kpl. Depósito de Combustible compl. Réservoir de Carburant compl.	26
Mounting frame Montageplatte Montageplatte Montageplatte	30
Heater cpl. Heizung, kpl. Calentador, acopl. Réchauffeur compl.	34
Hydronic Heater cpl. Wärmeübertragende Heizung, kpl. Calentador hidrónico, acopl. Réchauffeur caloporteur compl.	40
Reservoir/Piping Behälter/Verrohrung Depósito/tubería Réservoir/conduit	42
Reservoir/Piping Behälter/Verrohrung Depósito/tubería Réservoir/conduit	44
Filter cpl. Filter, kpl. Filtro, acopl. Filtre compl.	48
Fuel Filter Kraftstofffilter Filtro de Combustible Filtre à Carburant	50
Motor/Pump cpl. Motorpumpe, kpl. Motor bomba, acopl. Moteur, pompe compl.	52
Hose Reel cpl. Schlauchhaspel, kpl. Carrete de la manguera compl. Dévidoir enrouleur compl.	56

Indice

Table des matières

Genset Enclosure cpl. Genset-Gehäuse, kpl. Armario generador compl. Groupe électrogène compl.	62
Control Panel cpl. Betätigung kpl. Regulador compl. Commande compl.	64
Burner cpl. Brenner, kpl. Quemador, acopl. Brûleur compl.	66
Electrical Components Elektrische Bestandteile Piezas Eléctricas Parties Constituanates Électriques	70
Labels Aufkleber Calcomanias Autocollants	74
Labels Aufkleber Calcomanias Autocollants	76
Labels Aufkleber Calcomanias Autocollants	78
Wiring Diagram - Main Wiring Harness Schaltplan - Hauptkabelbaum Esquema de Distribución - Conjunto de Cables Princ Plan de Câblage - Harnais de Fils Électriques Prin	80
Wiring Schematic Schaltplan Diagrama de Cables Schéma de Câblage	82
E-Stop Box cpl. Not-Aus Kasten kpl. Caja de parada de emergencia compl. Boîte d'arrêt d'urgence compl.	86
Generator Service Parts Generatorenersatzteile Repuestos para Generadores Pièces Détachées des Groupes Électrogènes	89
Service Parts Ersatzteile Repuestos Pièces Détachées	90
Nozzle body (holder) Düse Tobera Ajutage	92
Cylinder Head Cover Zylinderkopfhaube Tapa del Cilindro Couvercle Supérieur	94

Flywheel Schwungrad Volante Volant	96
Generator Service Parts Generatorenersatzteile Repuestos para Generadores Pièces Détachées des Groupes Électrogènes	98
Fuel System Kraftstoffsystem Sistema de Combustible Système d'Essence	100
Manifold inlet Verteiler, Einlass Distribuidor, admisión Tubulure, admission	102
Air intake Ansaugstutzen Tubuladura de aspiración Tubulure d'aspiration	104
Water Manifold Wasser-Verteiler Distribuidor del agua Rampe d'arrosage	106
Water pump Wasserpumpe Bomba del agua Pompe à eau	108
Radiator Section cpl. Kühleranlage Conjunto Sector Radiateur Radiateur Compl.	110
Cooling System Kühlungssystem Sistema de Enfriamiento Système de Refroidissement	112
Oil dipstick Ölpeilstab Indicador del nivel de aceite Réglette-jauge d'huile	114
Vibration Reduction Kit Vibrationsverringersatz Juego reductor de vibración Jeu de ralentissement de vibration	116
Exhaust manifold Auspuffkrümmer Distribuidor de escape Collecteur d'échappement	118
Muffler cpl. Auspufftopf kpl. Silenciador compl. Pot d'Echappement compl.	120
Control Box Kontrollkasten Caja de Control Boîtier de Commande	122

Table of Contents
Inhaltsverzeichnis
Indice
Table des matières

HSH 650

Electrical Components
Elektrische Bestandteile
Piezas Eléctricas
Parties Constituanates Électriques

124

Generator Mount cpl.
Teile für Montage des Generators
Piezas para Montaje del Generador
Pièces pour Montage du Générateur

HSH 650

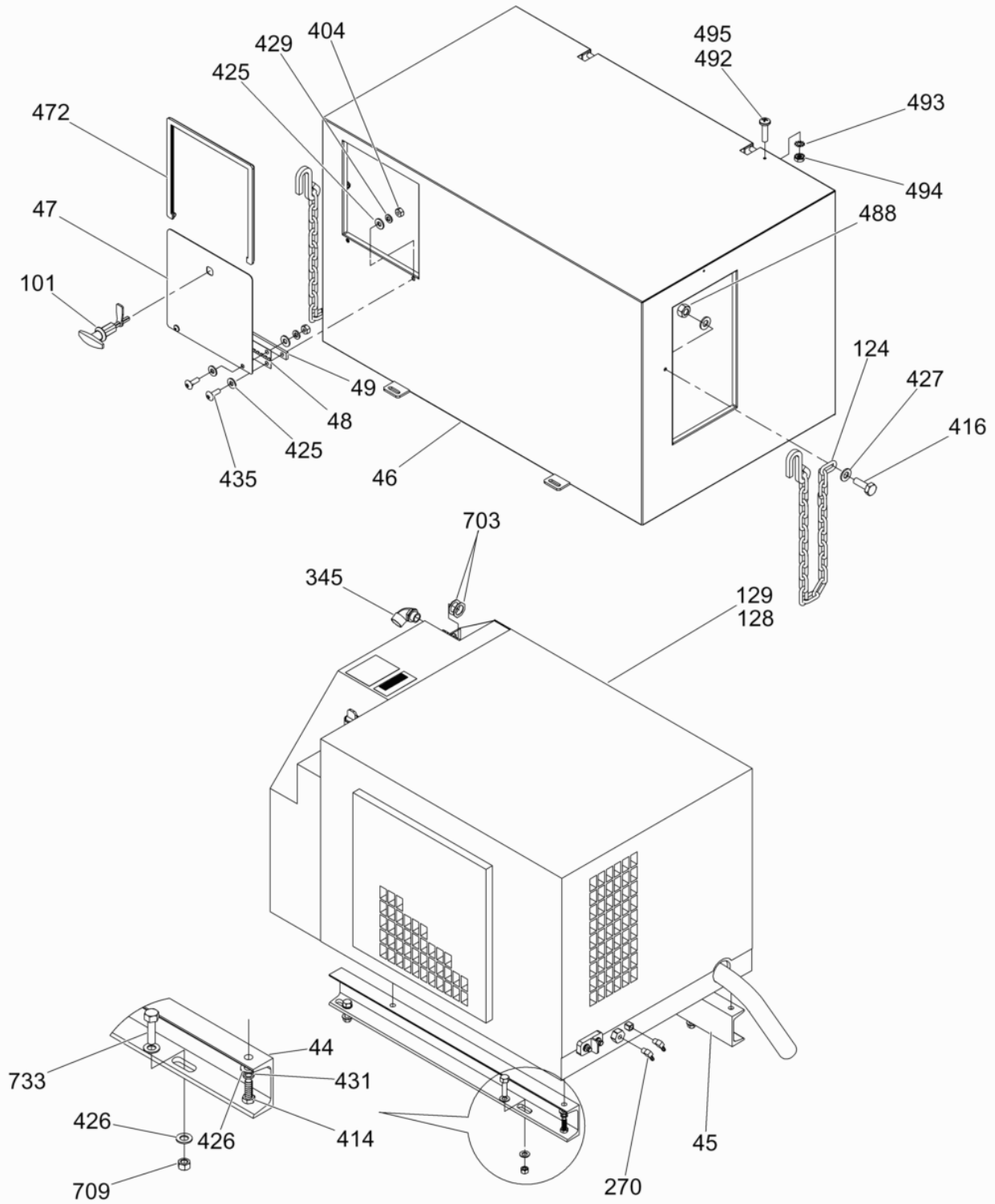

200_5000620243208024

Ref. Pos.	Part No. Artikel Nr.	Qty. St.	Description Beschreibung	Descripción Description	Measurem./Abm.	Norm
					Torque/Drehm.	Sealant Schmierstoff
44	0166947	1	Spacer Abstandsstück	Espaciador Entretoise		
45	0166946	1	Spacer Abstandsstück	Espaciador Entretoise		
46	0174006	1	Cover Deckel	Tapa Couvercle		
47	0174005	1	Door Tür	Puerta Porte		
48	0166948	1	Hinge Scharnier	Bisagra Charnière		
49	0166950	1	Spacer Abstandsstück	Espaciador Entretoise		
101	0174008	1	Handle Handgriff	Manija Poignée		
124	0168312	1	Safety chain set Sicherheitskettensatz	Juego de cadenas de seguridad Jeu de chaîne de sûreté	3/16 x 48	
128	0168889	1	Exhaust kit Auspuffsatz	Juego de escape Jeu d'échappement	5.5kW	
129	0176370	1	Generator Generator	Generador Générateur		
270	0168300	2	Hose barb Schlauchwiderhaken	Púa de manguera Barbelure de flexible	1/4 x 1/8in	
345	0181590	2	Fitting Verschraubung	Unión Raccord	1/2in-90	
404	0167690	2	Nut Mutter	Tuerca Écrou	1/4in - 20	
414	0167705	4	Bolt Bolzen	Perno Boulon	3/8-16 x 1in	
416	0167708	2	Bolt Bolzen	Perno Boulon	5/16-18 x 1in	
425	0167729	12	Flat washer Scheibe	Arandela elástica Rondelle de ressort	1/4in	
426	0167730	18	Flat washer Scheibe	Arandela elástica Rondelle de ressort	3/8in	
427	0167731	4	Washer-flat Unterlegscheibe	Arandela plana Rondelle	5/16in	
429	0167733	2	Lock washer Federring	Federring Rondelle de ressort	1/4in	
431	0167735	4	Lock washer Federring	Federring Rondelle de ressort	3/8in	
435	0167802	1	Screw Schraube	Tornillo Vis	1/4-20 x 3/4in	
472	0168354	1	Trim Einfassung	Protección Garniture	12ft	
488	0167694	2	Nut Mutter	Tuerca Écrou	5/16-18	
492	0167819	1	Screw Schraube	Tornillo Vis	10-32 x 3/4	
493	0181623	1	Washer Scheibe	Arandela Rondelle	No.10	

Generator Mount cpl.
Teile für Montage des Generators
Piezas para Montaje del Generador
Pièces pour Montage du Générateur

HSH 650

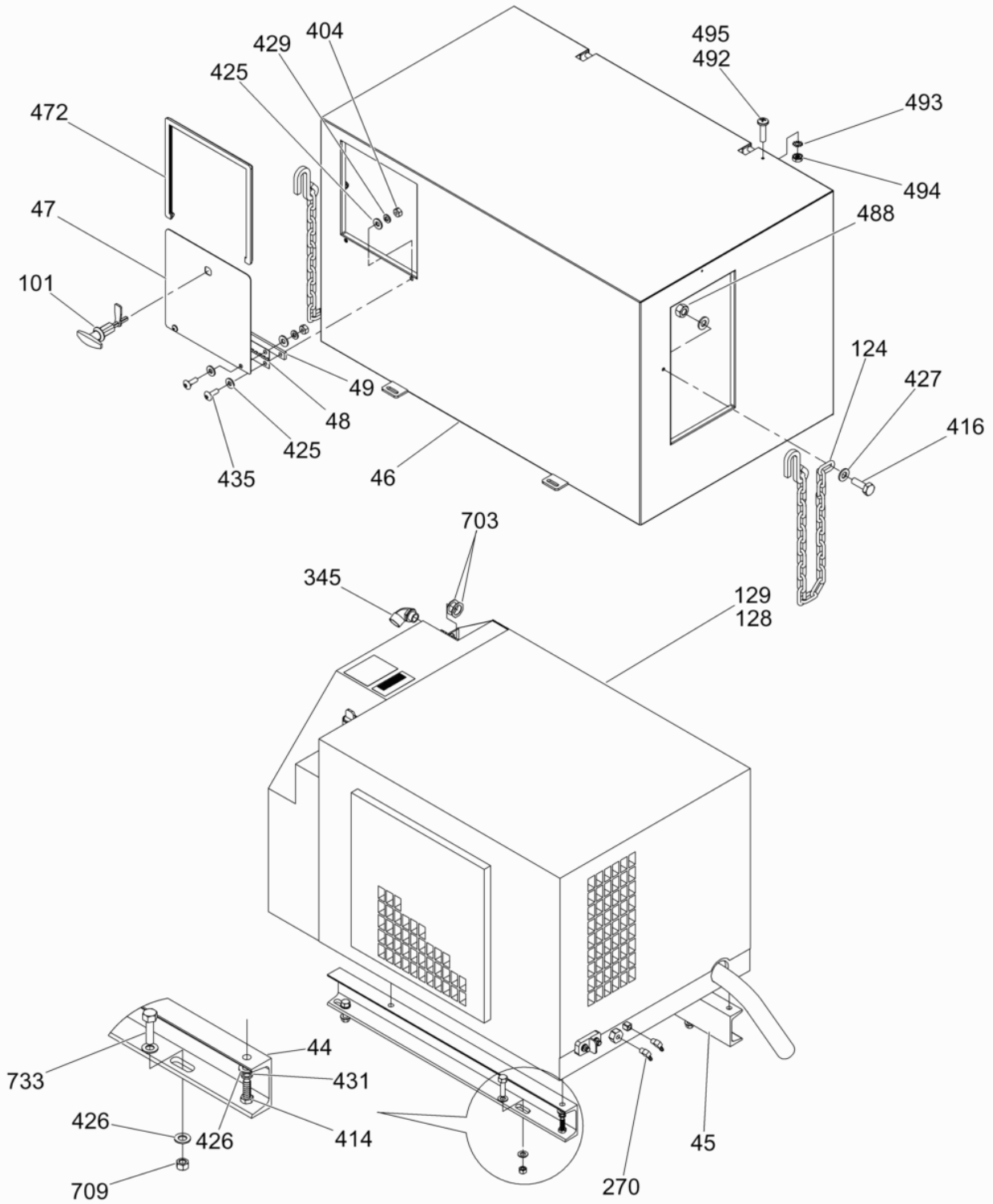

200_5000620243208024

Ref. Pos.	Part No. Artikel Nr.	Qty. St.	Description Beschreibung	Descripción Description	Measurement./Abm.	Norm
					Torque/Drehm.	Sealant Schmierstoff
494	0181624	1	Nut Mutter	Tuerca Écrou	No.10	
495	0177336	1	Ground wire Erdungsdraht	Alambre a tierra Fil de masse		
703	0181591	4	Washer Scheibe	Arandela Rondelle	3/4-1/2in	
709	0167778	4	Nut Mutter	Tuerca Écrou	3/8in-16	
733	0167750	4	Bolt Bolzen	Perno Boulon	3/8-16 x 1 1/2in	

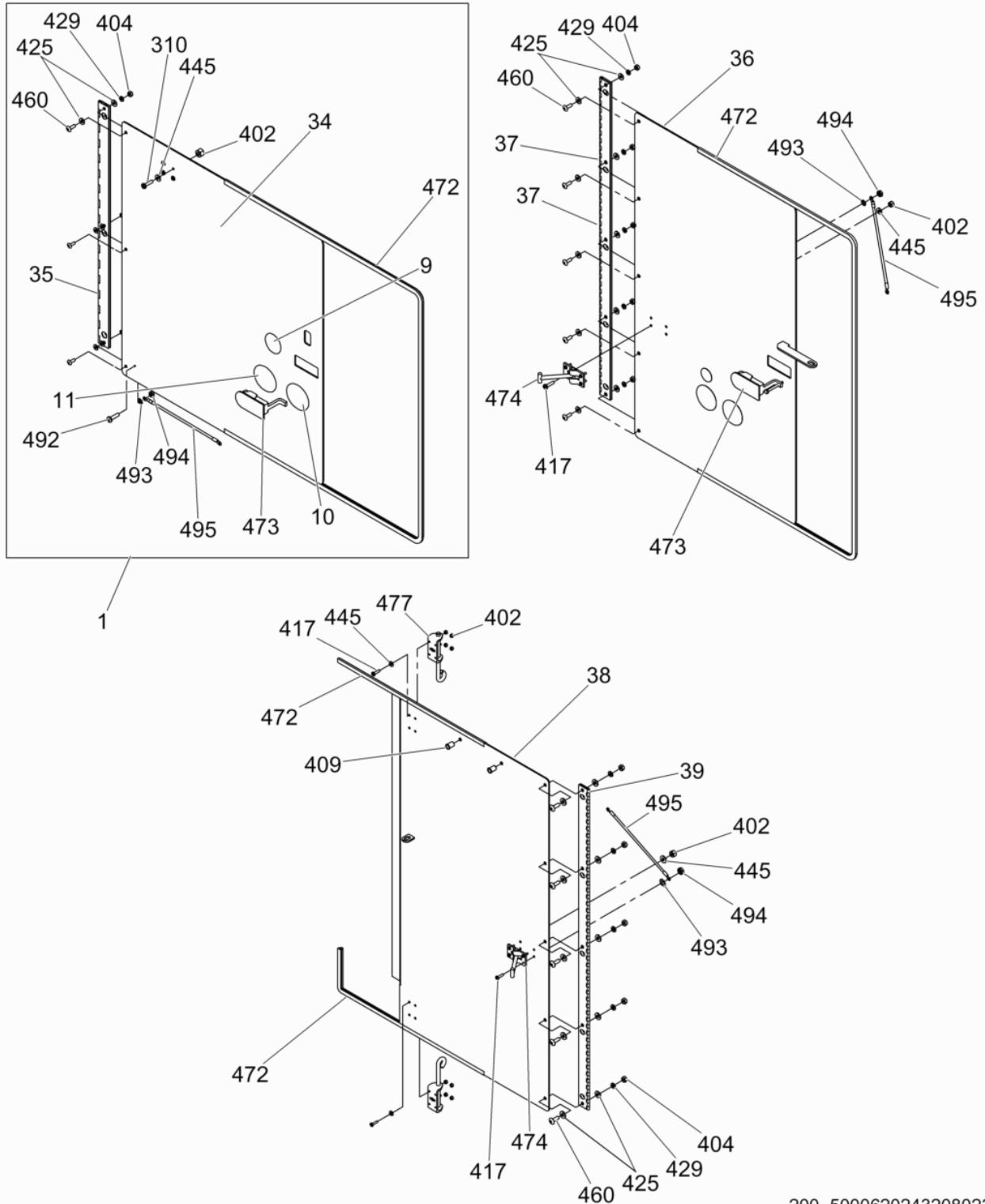

200_5000620243208023

Ref. Pos.	Part No. Artikel Nr.	Qty. St.	Description Beschreibung	Descripción Description	Measurem./Abm.	Norm
					Torque/Drehm.	Sealant Schmierstoff
9	0168895	1	Label-consult Operator's Manual Aufkleber	Calcomania Autocollant		
10	0168891	1	Label-safety gloves Aufkleber, Sicherheitshandschuhe	Calcomanía-guantes de seguridad Autocollant-gants de sécurité		
11	0168892	1	Label-eye protection Aufkleber	Calcomania Autocollant		
34	0180034	1	Left side door Linke Tür	Puerta costado izquierdo Porte gauche		
35	0172056	1	Hinge Scharnier	Bisagra Charnière		
36	0180332	1	Rear Left Door Linke Tür Hinten	Puerta Trasera Izquierda Porte-d'Arrière Gauche		
37	0167348	1	Hinge Scharnier	Bisagra Charnière		
38	0180333	1	Rear right door Blechtafel hinten & rechts	Panel trasero y derecha Tableau d'arrière et à droite		
39	0167352	1	Hinge Scharnier	Bisagra Charnière		
310	0170247	4	Screw Schraube	Tornillo Vis	No. 10-24 x 1	
402	0167688	6	Nut Mutter	Tuerca Écrou	10-24	
404	0167690	13	Nut Mutter	Tuerca Écrou	1/4in - 20	
409	0167700	2	Threaded insert Gewindeeinsatz	Inserción roscada Pièce d'insertion filetée	1/4-20	
417	0167709	8	Screw Schraube	Tornillo Vis	10-24 x 3/4	
425	0167729	13	Flat washer Scheibe	Arandela elástica Rondelle de ressort	1/4in	
429	0167733	13	Lock washer Federring	Federring Rondelle de ressort	1/4in	
445	0167788	8	Washer-flat Unterlegscheibe	Arandela plana Rondelle	No. 10	
460	0167857	13	Screw Schraube	Tornillo Vis	1/4-20 x 3/4	
472	0168354	3	Trim Einfassung	Protección Garniture	12ft	
473	0168398	2	Latch Verriegelung	Aldaba Loquet		
474	0168400	2	Holder Halter	Soporte Attache		
477	0168521	2	Spring Feder	Resorte Ressort		
492	0167819	1	Screw Schraube	Tornillo Vis	10-32 x 3/4	
493	0181623	3	Washer Scheibe	Arandela Rondelle	No.10	
494	0181624	3	Nut Mutter	Tuerca Écrou	No.10	

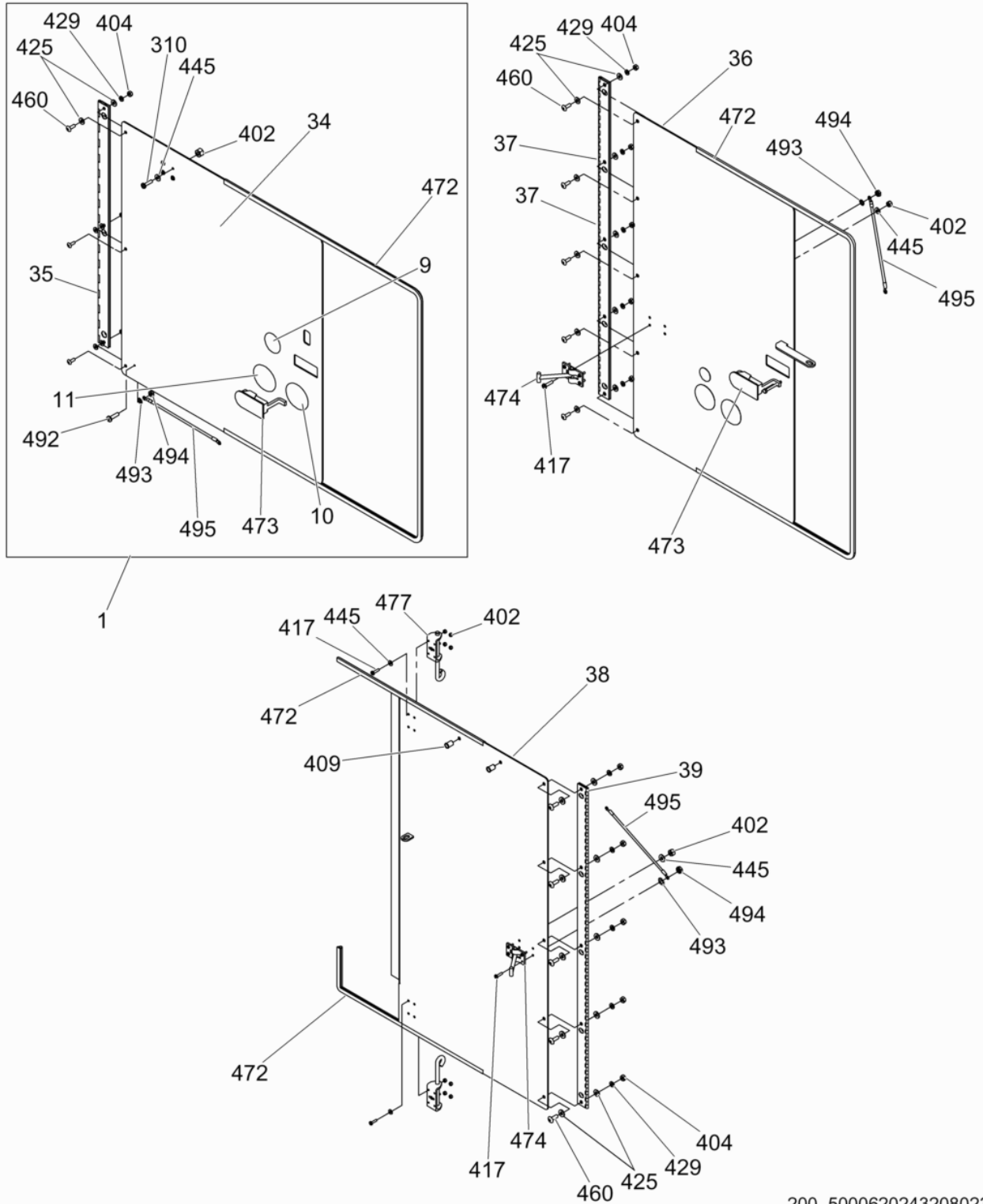

200_5000620243208023

Ref. Pos.	Part No. Artikel Nr.	Qty. St.	Description Beschreibung	Descripción Description	Measurem./Abm.	Norm
					Torque/Drehm.	Sealant Schmierstoff
495	0177336	3	Ground wire Erdungsdraht	Alambre a tierra Fil de masse		

Frame cpl.
Rahmen kpl.

HSH 650

Armazón compl.
Châssis compl.

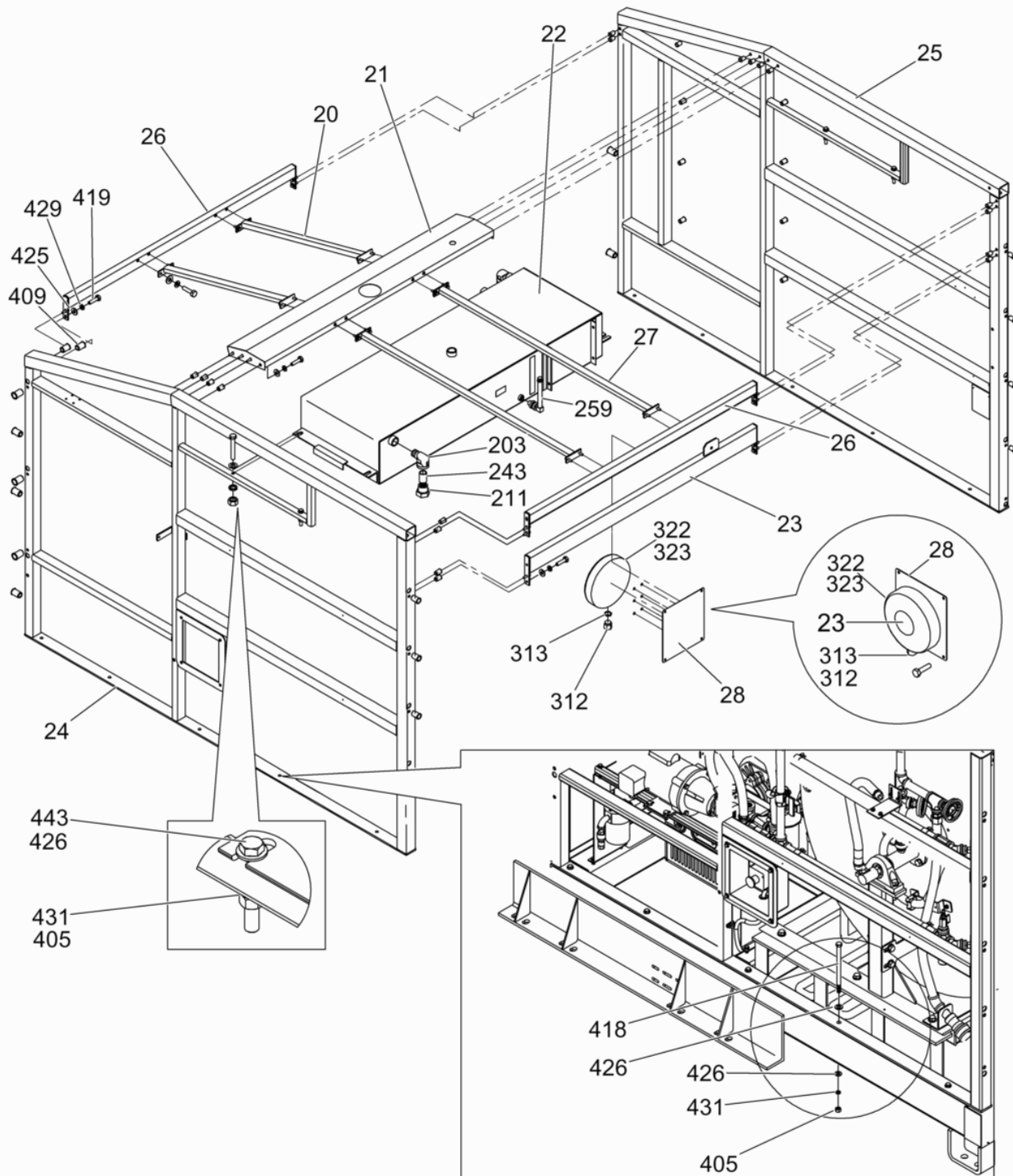

200_5000620243208014

Ref. Pos.	Part No. Artikel Nr.	Qty. St.	Description Beschreibung	Descripción Description	Measurem./Abm.	Norm
					Torque/Drehm.	Sealant Schmierstoff
20	0169572	2	Support Halter	Soporte Attache		
21	0169568	1	Brace Strebe	Apoyo Ventrière		
22	0169582	1	Expansion tank Expansionstank, kpl.	Tanque de expansión, acopl. Réservoir d'expansion compl.		
23	0169581	1	Cross tube Spurstange	Cruceta Tube transversal		
24	0172057	1	Frame-left side weldment Rahmen	Chasis Châssis		
25	0172062	1	Frame-right side weldment Rahmen	Chasis Châssis		
26	0169566	2	Cross tube Spurstange	Cruceta Tube transversal		
27	0169576	2	Support Halter	Soporte Attache		
28	0169682	1	Light bar bracket Konsole für Schlußleuchten	Soporte para barra de lámparas Support pour feux arrières		
203	0168029	2	Elbow Krümmer	Codo Coude	3/4in NPT	
211	0168058	2	Union Verbindung	Unión Raccord droit	3/4in NPT	
243	0168390	2	Nipple fitting Stutzen	Niple Raccord	3/4 x 1-1/2in	
259	0168805	1	Sight gauge Sichtanzeiger	Mirilla Niveau à vue	3/8 NPT x 7	
312	0166458	1	Cord grip Zugentlastung	Alivio de esfuerzos Effort à la décharge	1/2in	
313	0166459	1	Lock nut Sicherungsmutter	Contratuercas Contre-écrou		
322	0166793	1	Light fixture Licht	Artefacto Projecteur	50Hz	
323	0166794	1	Light bulb Glühlampe	Bombilla Ampoule	50Hz/250V	
405	0167691	4	Nut Mutter	Tuerca Écrou	3/8in - 16	
409	0167700	54	Threaded insert Gewindeeinsatz	Inserción roscada Pièce d'insertion filetée	1/4-20	
418	0167720	10	Bolt Bolzen	Perno Boulon	3/8-16 x 6in	
419	0167721	36	Bolt Bolzen	Perno Boulon	1/4-20 x 1in	
425	0167729	36	Flat washer Scheibe	Arandela elástica Rondelle de ressort	1/4in	
426	0167730	4	Flat washer Scheibe	Arandela elástica Rondelle de ressort	3/8in	
429	0167733	36	Lock washer Federring	Federring Rondelle de ressort	1/4in	
431	0167735	4	Lock washer Federring	Federring Rondelle de ressort	3/8in	

Frame cpl.
Rahmen kpl.

HSH 650

Armazón compl.
Châssis compl.

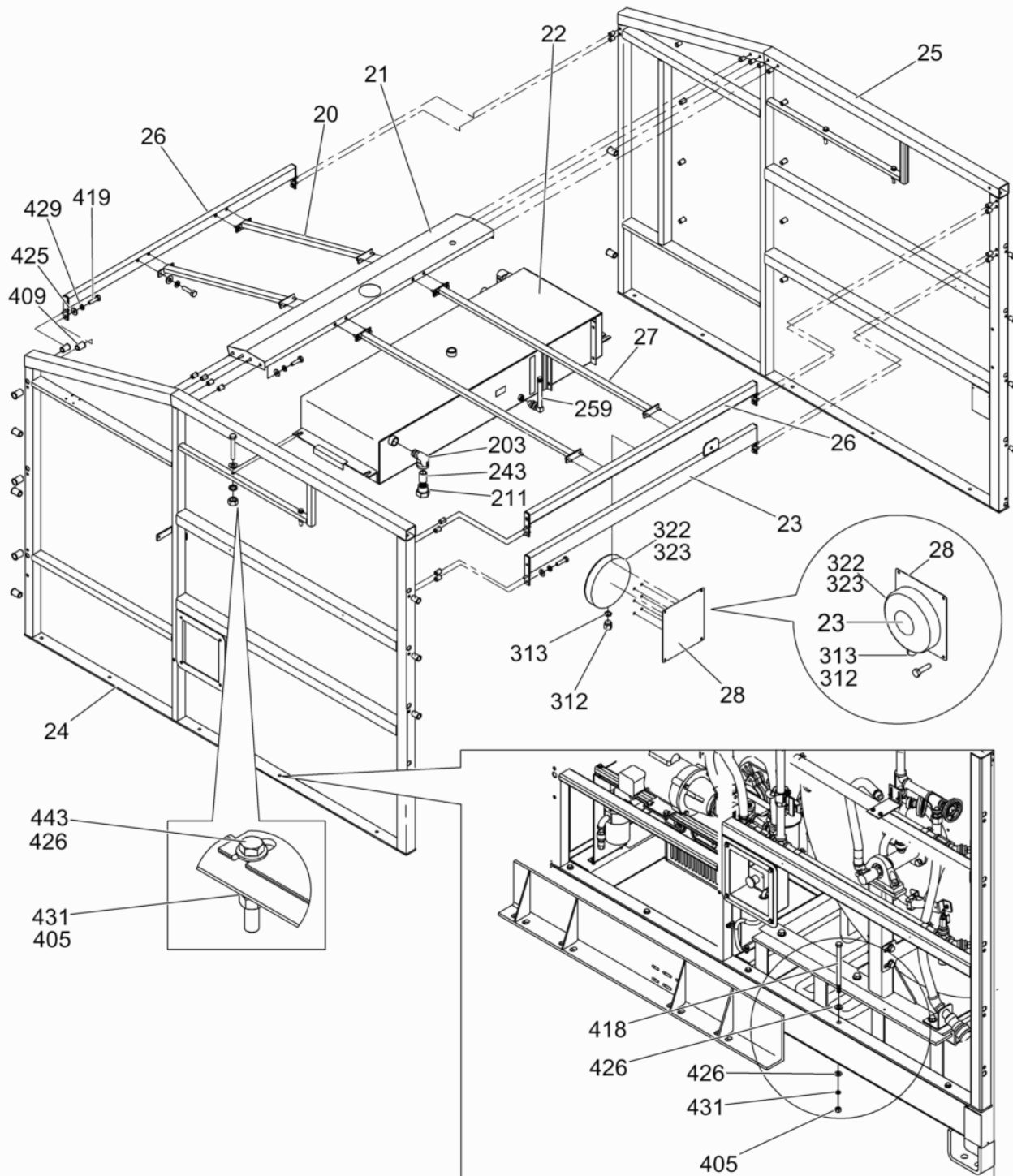

200_5000620243208014

Ref. Pos.	Part No. Artikel Nr.	Qty. St.	Description Beschreibung	Descripción Description	Measurement./Abm.	Norm
					Torque/Drehm.	Sealant Schmierstoff
433	0167777	4	Bolt Bolzen	Perno Boulon	3/8-16 x 2-1/2in	

Covers cpl.
 Abdeckungen, kpl.
 Tapas compl.
 Capots cpl.

HSH 650

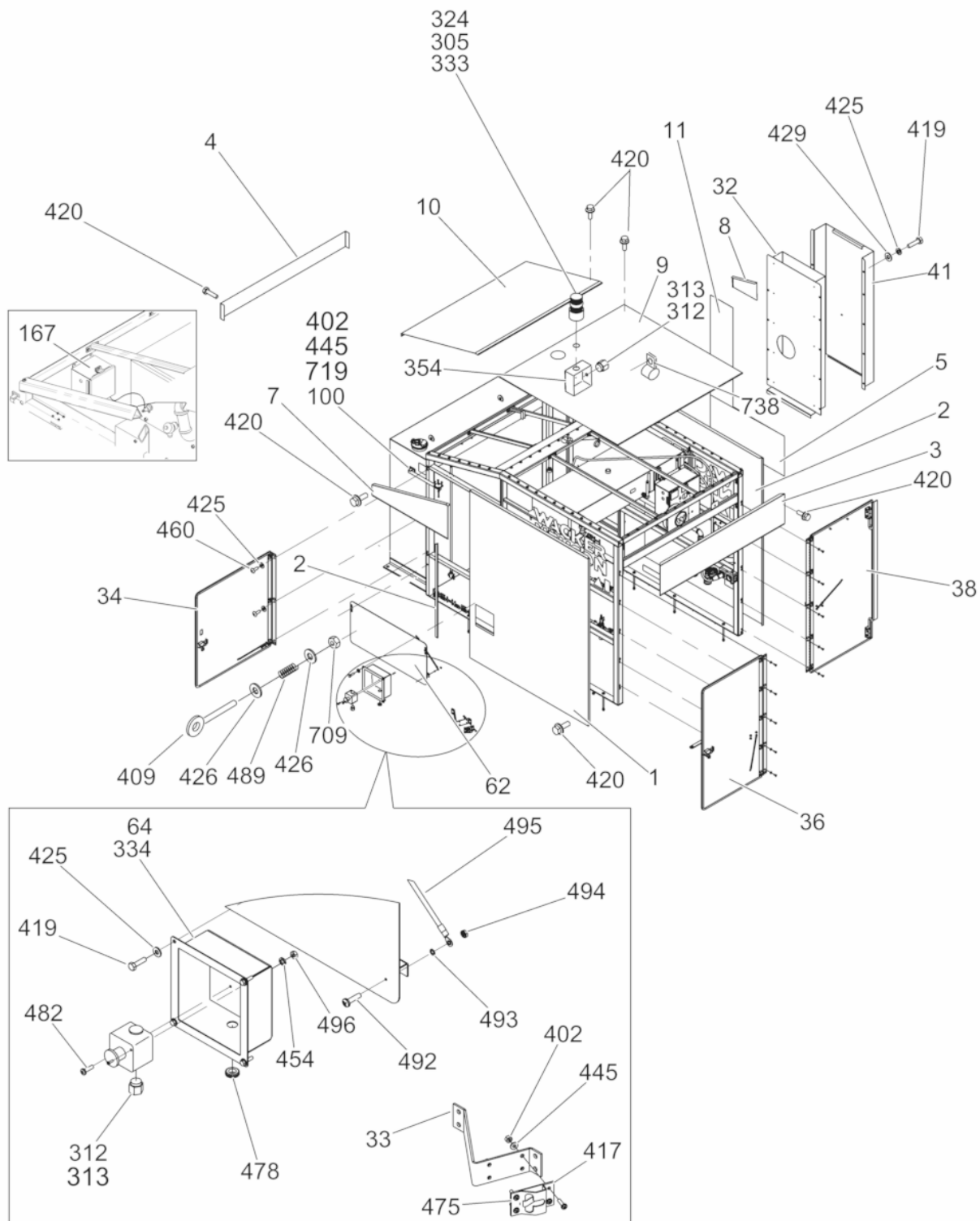

200_5000620243208020

Ref. Pos.	Part No. Artikel Nr.	Qty. St.	Description Beschreibung	Descripción Description	Measurement./Abm.	Norm
					Torque/Drehm.	Sealant Schmierstoff
1	0180226	1	Left Side Cover Kit Deckelsatz	Juego-tapa Jeu-couvercle		
2	0180530	1	Cover plate Deckplatte	Placa de cubierta Couvercle de protection		
3	0181032	1	Above Rear Door Cover Kit Deckelsatz	Juego-tapa Jeu-couvercle		
5	0181045	1	Right Side Below Exhaust Cover Kit Deckelsatz	Juego-tapa Jeu-couvercle		
7	0180186	1	Left Side Above Door Cover Kit Deckelsatz	Juego-tapa Jeu-couvercle		
9	0181043	1	Rear Roof Cover Kit Deckelsatz	Juego-tapa Jeu-couvercle		
10	0180217	1	Front Roof Cover Kit Deckelsatz	Juego-tapa Jeu-couvercle		
11	0181047	1	Right Side Front Corner CoverKit Deckelsatz	Juego-tapa Jeu-couvercle		
32	0167144	1	Inner exhaust stack cpl. Innere Auspuffplatte	Placa de escape interna Plaque d'échappement interne		
33	0179305	2	Bracket Konsole	Soporte Support		
34	0180588	1	Left side door Linke Tür	Puerta costado izquierdo Porte gauche		
36	0180333	1	Rear right door Blechtafel hinten & rechts	Panel trasero y derecha Tableau d'arrière et à droite		
38	0180332	1	Rear Left Door Linke Tür Hinten	Puerta Trasera Izquierda Porte-d'Arrière Gauche		
41	0167127	1	Stack guard Schachtschutz	Protector del tubo Cheminée		
62	0180227	1	Lower panel Unteres Panel	Panel inferior Panneau inférieur		
100	0168686	1	Hatch holder Lukenhalter	Sujetaescotilla Retenue de porte	7/8in	
167	0166239	1	Panel cpl. Panel kpl.	Panel compl. Tableau compl.		
305	0166792	1	Plug Stopfen	Tapón Bouchon		
312	0166458	2	Cord grip Zugentlastung	Alivio de esfuerzos Effort à la décharge	1/2in	
313	0166459	1	Lock nut Sicherungsmutter	Contratuercas Contre-écrou		
324	0166800	1	Cable Kabel	Cable Câble	16/3	
329	0172078	1	Emergency stop switch Not-Aus Schalter	Interruptor de parada de emergencia Interrupteur d'arrêt d'urgence		
333	0166797	1	Light Lampe	Lámpara Lampe		
351	0181052	1	Bracket Konsole	Soporte Support		
354	5200004285	1	Box Kasten	Caja Boîte		

Covers cpl.
 Abdeckungen, kpl.
 Tapas compl.
 Capots cpl.

HSH 650

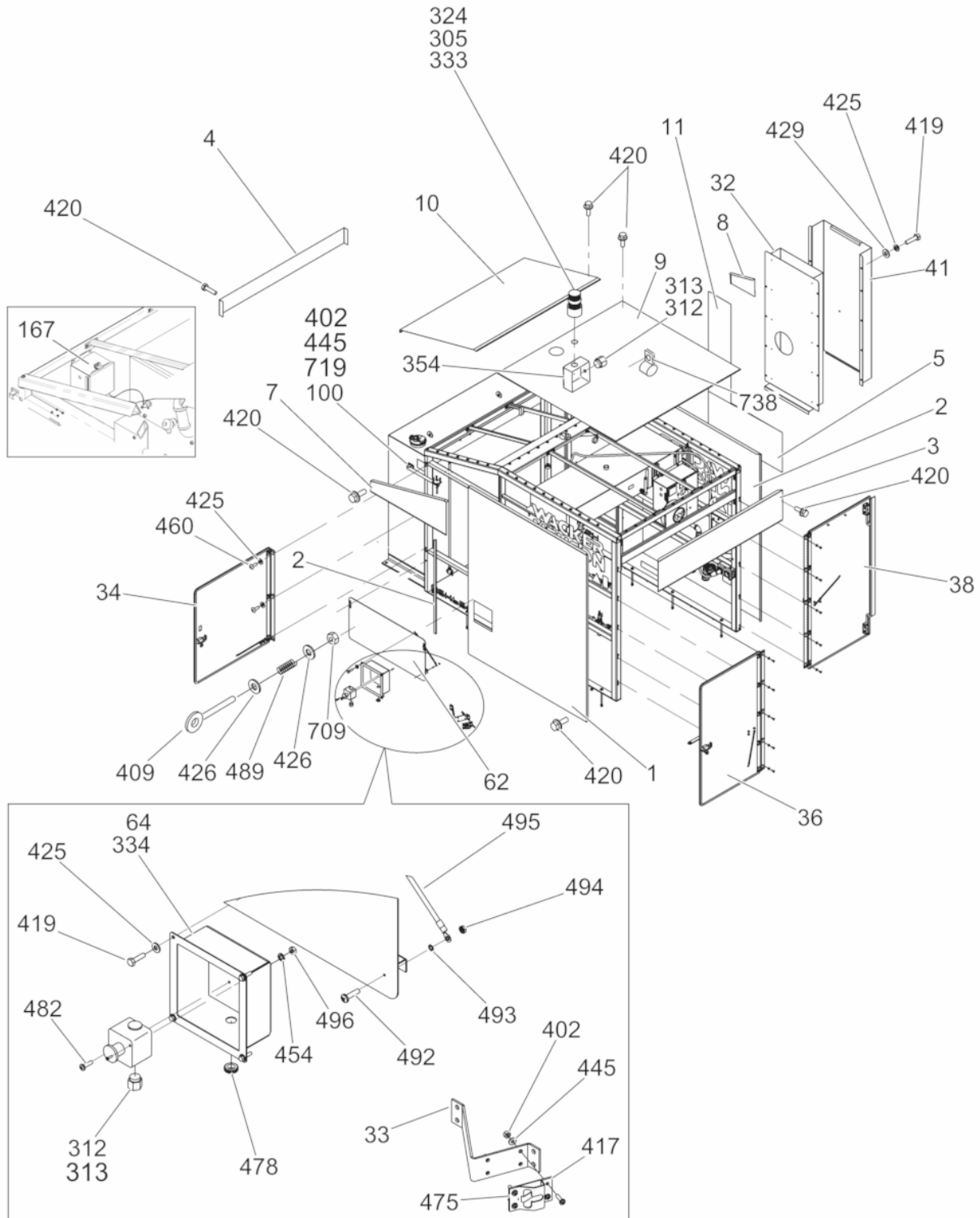

200_5000620243208020

Ref. Pos.	Part No. Artikel Nr.	Qty. St.	Description Beschreibung	Descripción Description	Measurem./Abm.	Norm
					Torque/Drehm.	Sealant Schmierstoff
402	0167688	8	Nut Mutter	Tuerca Écrou	10-24	
417	0167709	8	Screw Schraube	Tornillo Vis	10-24 x 3/4	
419	0167721	10	Bolt Bolzen	Perno Boulon	1/4-20 x 1in	
420	0167722	135	Screw w/washer Schraube mit Scheibe	Tornillo con arandela Vis avec rondelle	10 x 3/4	
425	0167729	10	Flat washer Scheibe	Arandela elástica Rondelle de ressort	1/4in	
426	0167730	2	Flat washer Scheibe	Arandela elástica Rondelle de ressort	3/8in	
429	0167733	10	Lock washer Federring	Federring Rondelle de ressort	1/4in	
445	0167788	8	Washer-flat Unterlegscheibe	Arandela plana Rondelle	No. 10	
454	0167838	2	Washer Scheibe	Arandela Rondelle	No. 6	
460	0167857	13	Screw Schraube	Tornillo Vis	1/4-20 x 3/4	
475	0168402	2	Holder-door Halter	Soporte Attache		
478	0168769	1	Grommet Tülle	Ojal Passe-fil	5/8in ID x 7/8in	
482	0167836	2	Screw Schraube	Tornillo Vis	6-32x 1/2	
489	0167906	2	Spring Feder	Resorte Ressort		
490	0172375	2	Eye bolt Ösenschraubbolzen	Perno de argolla Boulon d'oeil	3/8-16 x 4in	
492	0167819	1	Screw Schraube	Tornillo Vis	10-32 x 3/4	
493	0181623	1	Washer Scheibe	Arandela Rondelle	No.10	
494	0181624	1	Nut Mutter	Tuerca Écrou	No.10	
495	0177336	1	Ground wire Erdungsdraht	Alambre a tierra Fil de masse		
496	0167850	2	Nut Mutter	Tuerca Écrou	6-32	
709	0167778	2	Nut Mutter	Tuerca Écrou	3/8in-16	
719	0167910	4	Screw Schraube	Tornillo Vis	10-24 x 1.5	
738	0168316	1	Clamp Schelle	Abrazadera Agrafe		

Fuel Tank cpl.
Kraftstofftank kpl.

HSH 650

Depósito de Combustible compl.
Réservoir de Carburant compl.

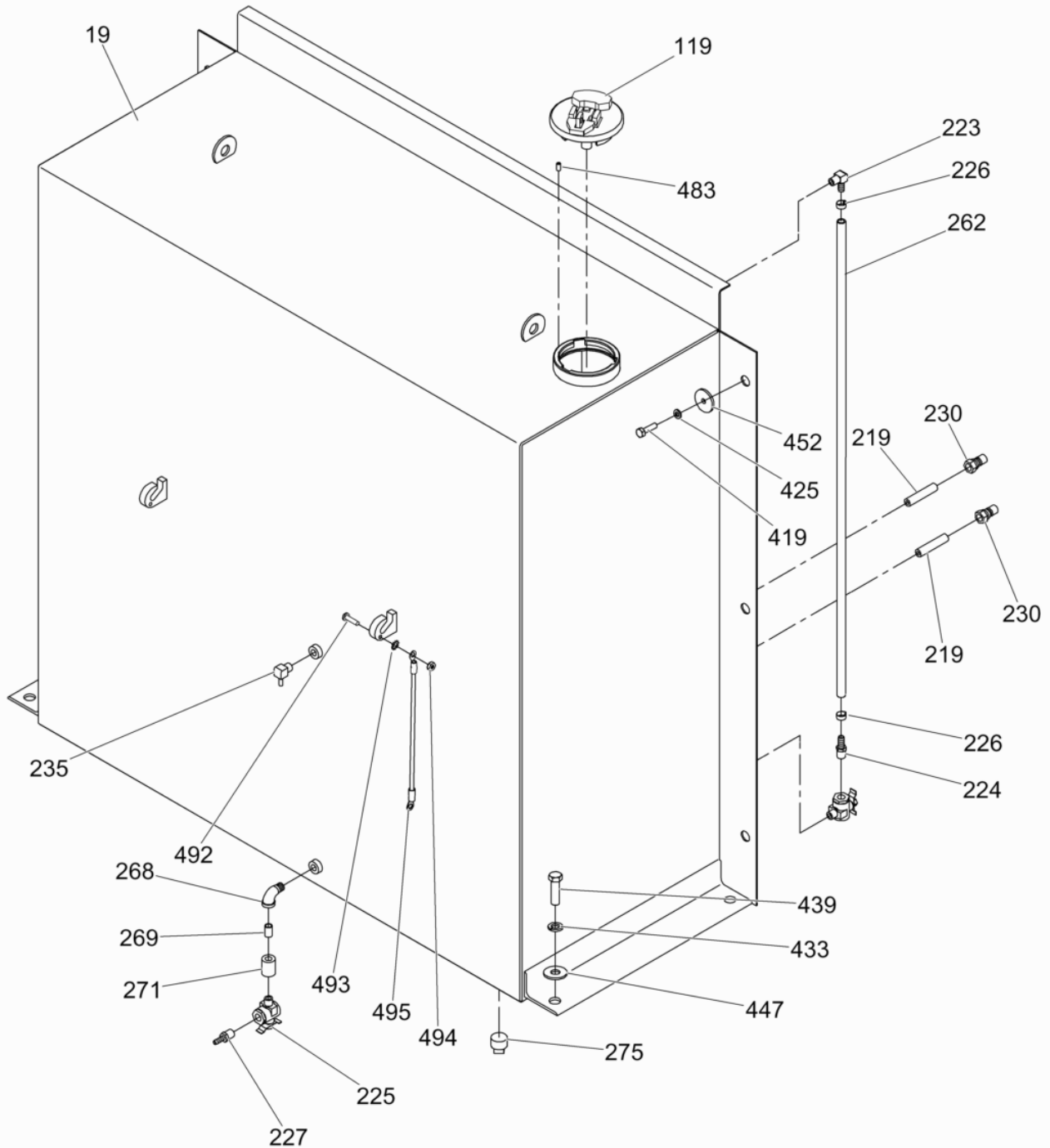

200_5000620243208018

Ref. Pos.	Part No. Artikel Nr.	Qty. St.	Description Beschreibung	Descripción Description	Measurem./Abm.	Norm
					Torque/Drehm.	Sealant Schmierstoff
19	0184540	1	Fuel tank Kraftstofftank	Depósito de combustible Réservoir de carburant		
119	0176369	1	Fuel tank cap Tankverschluß	Tapa del tanque Chapeau de réservoir		
219	0168231	2	Nipple fitting Stutzen	Niple Raccord	1/4 NPT x 2-1/2in	
223	0168279	1	Barbed hose fitting Schlauchverschraubung mit Stecknippel	Unión de mangueras con púas Accouplement de tuyau avec raccord cannelé	3/8 x 1/4in	
224	0168280	1	Hose barb Schlauchwiderhaken	Púa de manguera Barbelure de flexible	3/8 x 1/4in	
225	0168281	2	Valve Ventil	Válvula Soupape		
226	0168282	2	Hose clamp Schlauchschelle	Abrazaderas de manguera Agrafe de tuyau		
227	0168284	1	Hose barb Schlauchwiderhaken	Púa de manguera Barbelure de flexible	1/4 x 1/4in	
230	0168295	3	Coupling Kupplung	Acoplamiento Accouplement		
235	0168367	1	Hose barb Schlauchwiderhaken	Púa de manguera Barbelure de flexible	1/4 x 1/4in	
262	0169400	1	Tubing Schläuche	Tubos Gaine	3/8in ID	
268	0168031	1	Elbow Krümmer	Codo Coude	1/4in NPT	
269	0168062	1	Nipple fitting Stutzen	Niple Raccord	1/4in NPT	
271	0168678	1	Coupling Kupplung	Acoplamiento Accouplement	1/4in NPT	
275	0168154	1	Plug Stopfen	Tapón Bouchon	3/4in NPT	
419	0167721	6	Bolt Bolzen	Perno Boulon	1/4-20 x 1in 11Nm/8ft.lbs	
425	0167729	6	Flat washer Scheibe	Arandela elástica Rondelle de ressort	1/4in	
433	0167737	4	Washer-lock Federring	Arandela elástica Rondelle de ressort	7/16in	
439	0167764	4	Bolt Bolzen	Perno Boulon	7/16 - 14 x 1 1/2in 64Nm/47ft.lbs	
447	0167808	4	Fender washer Unterlegscheibe	Arandela Rondelle	1/2 x 1-1/4	
452	0167833	6	Fender washer Unterlegscheibe	Arandela Rondelle	1/4 x 1-1/4	
483	0168611	1	Clip Befestigung	Clip Clip	1/16in	
492	0167819	1	Screw Schraube	Tornillo Vis	10-32 x 3/4	
493	0181623	1	Washer Scheibe	Arandela Rondelle	No.10	

Fuel Tank cpl.
Kraftstofftank kpl.

HSH 650

Depósito de Combustible compl.
Réservoir de Carburant compl.

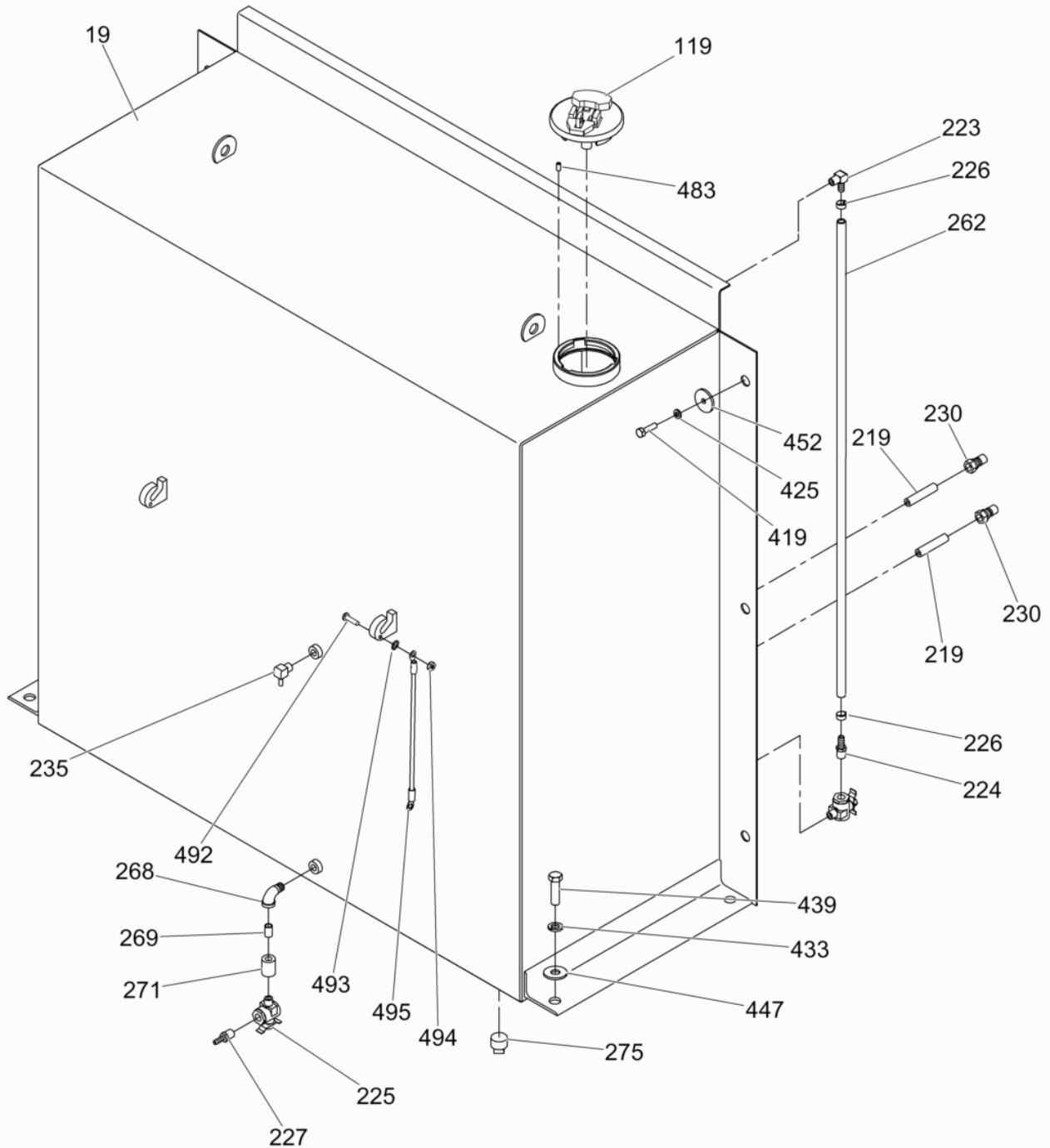

200_5000620243208018

Ref. Pos.	Part No. Artikel Nr.	Qty. St.	Description Beschreibung	Descripción Description	Measurement/Abm.	Norm
					Torque/Drehm.	Sealant Schmierstoff
494	0181624	1	Nut Mutter	Tuerca Écrou	No.10	
495	0177336	1	Ground wire Erdungsdraht	Alambre a tierra Fil de masse		

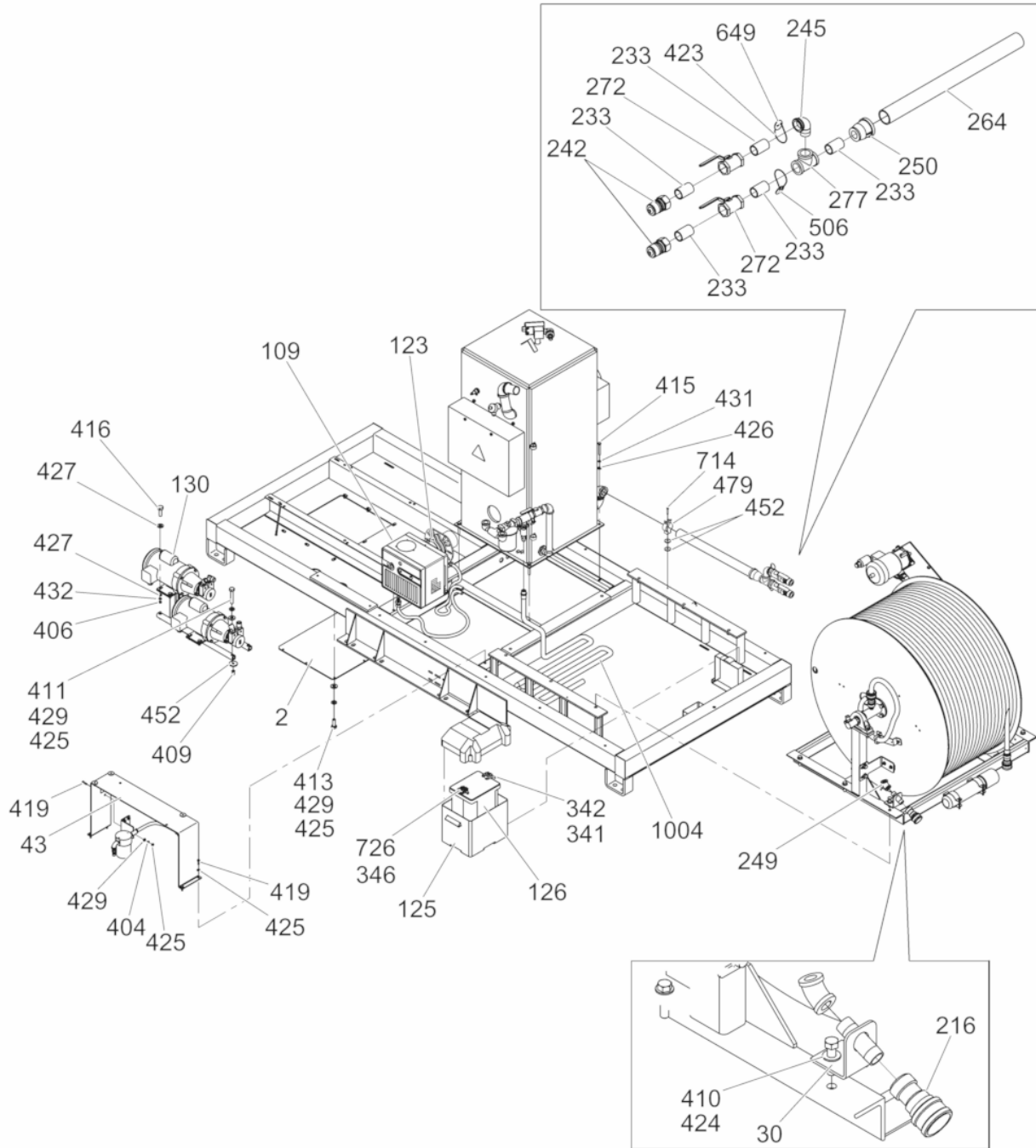

200_5000620991103013

Ref. Pos.	Part No. Artikel Nr.	Qty. St.	Description Beschreibung	Descripción Description	Measurem./Abm.	Norm
					Torque/Drehm.	Sealant Schmierstoff
2	0180530	1	Cover plate Deckplatte	Placa de cubierta Couvercle de protection		
30	0169689	1	Bracket Konsole	Soporte Support		
43	0169778	1	Bracket Konsole	Soporte Support		
109	0168077	1	Burner Brenner	Quemador Brûleur	50Hz	
123	0168773	2	Spacer plates Abstandsplatten	Placas espaciadoras Plaquettes entretoises	25mm	
125	0168169	1	Battery box Batteriekasten	Caja de bateria Boîte de batterie		
126	0165552	1	Battery Batterie	Bateria Batterie	12V	
130	0168756	2	Motor Motor	Motor Moteur	1/2hp	
216	0168213	1	Quick connect Schnellkupplung	Conexión rápida Branchement rapide	3/4 NPT	
233	0168331	7	Nipple fitting Stutzen	Niple Raccord	1 NPT x 2in	
242	0168385	2	Coupling Kupplung	Acoplamiento Accouplement	1 NPT	
245	0168403	1	Elbow fitting Rohrkrümmer	Codo Raccord coudé	1in	
249	0168498	1	Elbow Krümmer	Codo Coude	3/4in NPT	
250	0168634	1	Coupling Kupplung	Acoplamiento Accouplement		
264	0169413	1	Pipe Rohr	Tubo Conduit	1-1/2in	
272	0168330	2	Valve Ventil	Válvula Soupape		
277	0168326	1	Tee-fitting T-Verschraubung	Unión forma T Raccord T	1in NPT	
341	0166649	3	Ring terminal Geschlossen. Kabelschuh	Terminal de anillo Cosse de câble à plage fermée	3/8in	
342	0166650	1	Terminal Anschlußklemme	Terminal de conexión Borne d'attache		
346	0180004	1	Terminal Anschlußklemme	Terminal de conexión Borne d'attache		
404	0167690	8	Nut Mutter	Tuerca Écrou	1/4in - 20	
406	0167692	8	Nut Mutter	Tuerca Écrou	5/16in - 18	
409	0167700	4	Threaded insert Gewindeeinsatz	Inserción roscada Pièce d'insertion filetée	1/4-20	
410	0167701	6	Bolt Bolzen	Perno Boulon	1/2-3 x 2in	
411	0167702	4	Bolt Bolzen	Perno Boulon	1/4-20 x 1-1/2in	

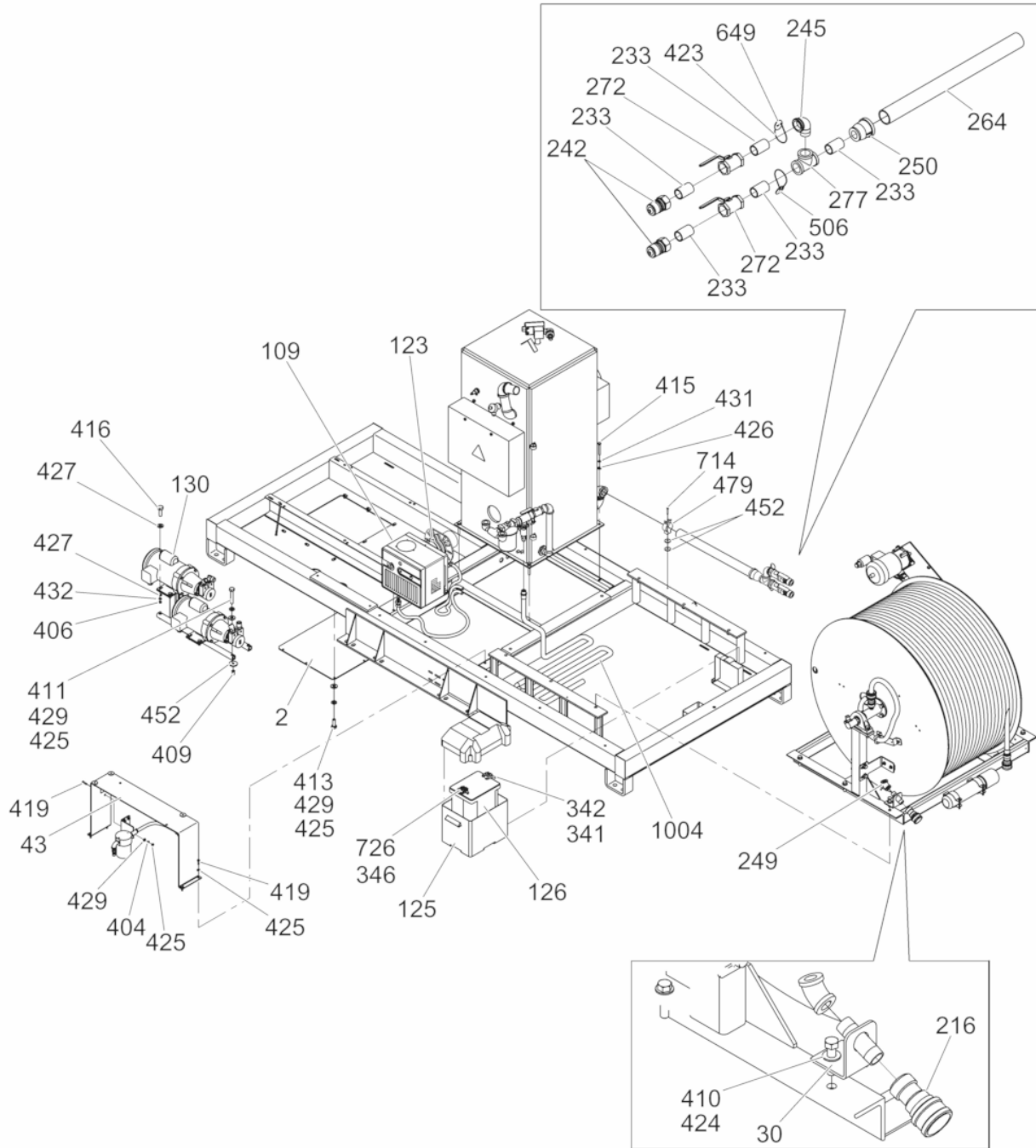

200_5000620991103013

Ref. Pos.	Part No. Artikel Nr.	Qty. St.	Description Beschreibung	Descripción Description	Measurem./Abm.	Norm
					Torque/Drehm.	Sealant Schmierstoff
413	0167704	7	Bolt Bolzen	Perno Boulon	1/4-20 x 3/4in	
415	0167706	4	Bolt Bolzen	Perno Boulon	3/8-16 x 3in	
416	0167708	8	Bolt Bolzen	Perno Boulon	5/16-18 x 1in	
419	0167721	8	Bolt Bolzen	Perno Boulon	1/4-20 x 1in	
423	0167727	1	Tie wire Bandagendraht	Alambre para ataduras Fil de frettage	8in	
424	0167728	6	Flat washer Scheibe	Arandela elástica Rondelle de ressort	1/2in	
425	0167729	19	Flat washer Scheibe	Arandela elástica Rondelle de ressort	1/4in	
426	0167730	4	Flat washer Scheibe	Arandela elástica Rondelle de ressort	3/8in	
427	0167731	16	Washer-flat Unterlegscheibe	Arandela plana Rondelle	5/16in	
429	0167733	15	Lock washer Federring	Federring Rondelle de ressort	1/4in	
431	0167735	4	Lock washer Federring	Federring Rondelle de ressort	3/8in	
432	0167736	8	Washer-lock Federring	Arandela elástica Rondelle de ressort	5/16in	
452	0167833	2	Fender washer Unterlegscheibe	Arandela Rondelle	1/4 x 1-1/4	
479	0167733	1	Lock washer Federring	Federring Rondelle de ressort	1/4in	
506	0168186	1	Tag No. 1 Anhängeschild Nr. 1	Etiqueta No. 1 Étiquette No. 1		
649	0168190	1	Tag No. 5 Anhängeschild Nr. 5	Etiqueta No. 5 Étiquette No. 5		
714	0167929	1	Screw Schraube	Tornillo Vis	No. 12 x 1-1/2	
726	5200000290	1	Ring terminal Geschlossen. Kabelschuh	Terminal de anillo Cosse de câble à plage fermée		
1004	0165632	1	Fill hose cpl. Füllschlauch	Manguera de llenado Tuyau de remplissage		

Heater cpl.
 Heizung, kpl.
 Calentador, acopl.
 Réchauffeur compl.

HSH 650

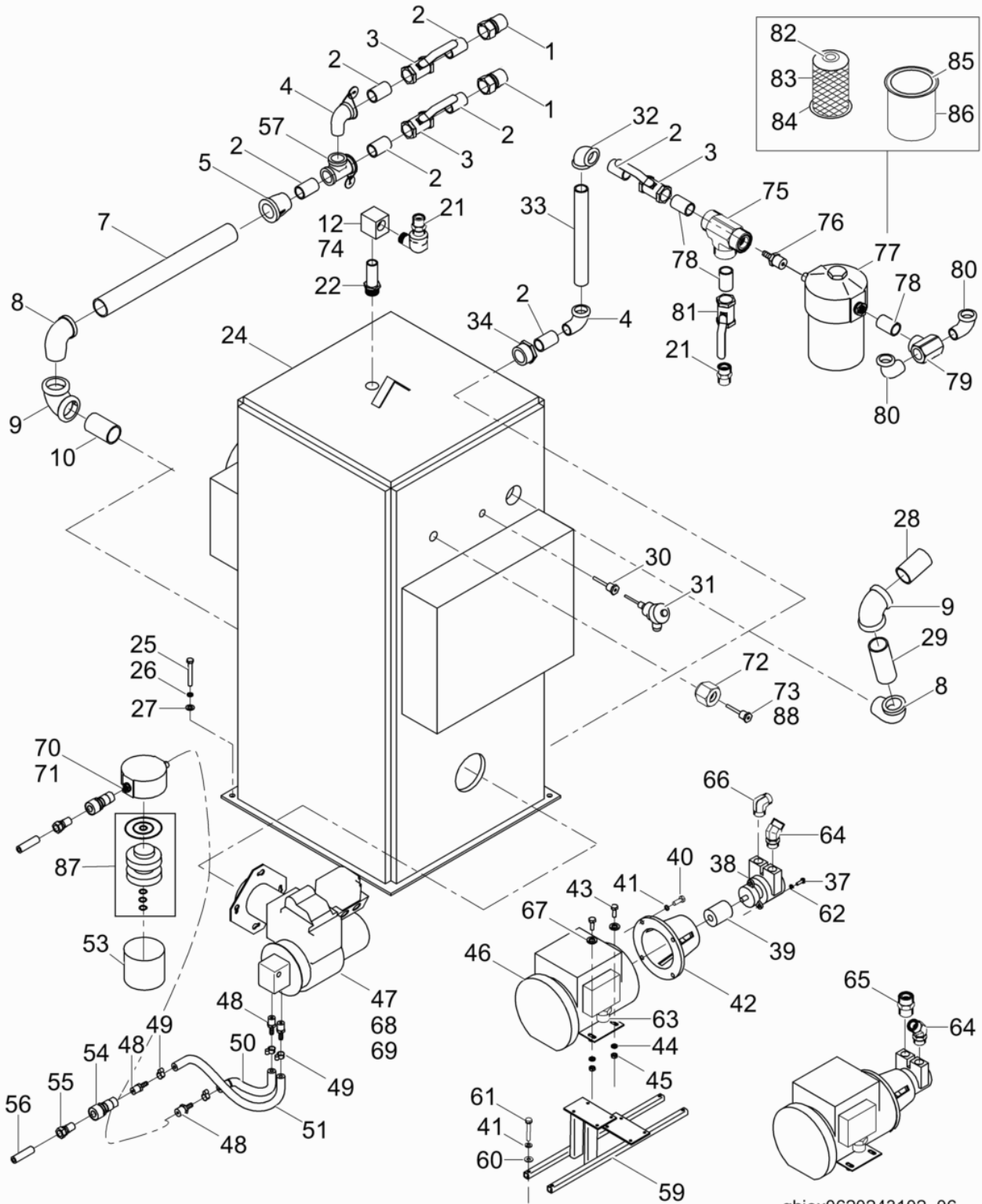

ghiex0620243102_06

Ref. Pos.	Part No. Artikel Nr.	Qty. St.	Description Beschreibung	Descripción Description	Measurem./Abm.	Norm
					Torque/Drehm.	Sealant Schmierstoff
1	0168385	2	Coupling Kupplung	Acoplamiento Accouplement	1 NPT	
2	0168331	7	Nipple fitting Stutzen	Niple Raccord	1 NPT x 2in	
3	0168330	3	Valve Ventil	Válvula Soupape		
4	0168403	2	Elbow fitting Rohrkrümmer	Codo Raccord coudé	1in	
5	0168634	1	Coupling Kupplung	Acoplamiento Accouplement		
7	0169413	1	Pipe Rohr	Tubo Conduit	1-1/2in	
8	0168030	2	Elbow Krümmer	Codo Coude	1-1/2in NPT	
9	0168459	2	Elbow Krümmer	Codo Coude	1 1/2in NPT	
10	0168707	1	Nipple fitting Stutzen	Niple Raccord	1.50 x 3in	
12	0165639	1	Snap switch cpl. Sprengschalter kpl.	Interruptor de retención compl. Interrupteur extérieur compl.		
21	0168372	1	Adapter Adapter	Adaptador Raccord	3/4 x 5/8in	
22	0168700	1	Nipple fitting Stutzen	Niple Raccord	3/4 x 3in	
24	0168247	1	Boiler Boiler	Caldera Chaudière		
25	0167706	4	Bolt Bolzen	Perno Boulon	3/8-16 x 3in	
26	0167735	4	Lock washer Federring	Federring Rondelle de ressort	3/8in	
27	0167730	8	Flat washer Scheibe	Arandela elástica Rondelle de ressort	3/8in	
28	0169413	1	Pipe Rohr	Tubo Conduit	1-1/2in	
29	0168705	1	Nipple fitting Stutzen	Niple Raccord	1.5 x 4.5	
30	0166711	1	Thermowell Thermoschutzrohr	Termopozo Sonde thermométrique	1/4 x 2-1/2 NPT	
31	0166712	1	Thermocouple Thermoement	Termopar Thermocouple		
32	0168328	1	Elbow Krümmer	Codo Coude	1in NPT	
33	0168704	1	Nipple fitting Stutzen	Niple Raccord	1 x 11in	
34	0168324	1	Bushing Buchse	Buje Douille	1-1/2 x 1in	
37	0167704	6	Bolt Bolzen	Perno Boulon	1/4-20 x 3/4in	
38	0168277	2	Pump Pumpe	Bomba Pompe	265gph	

Heater cpl.
 Heizung, kpl.
 Calentador, acopl.
 Réchauffeur compl.

HSH 650

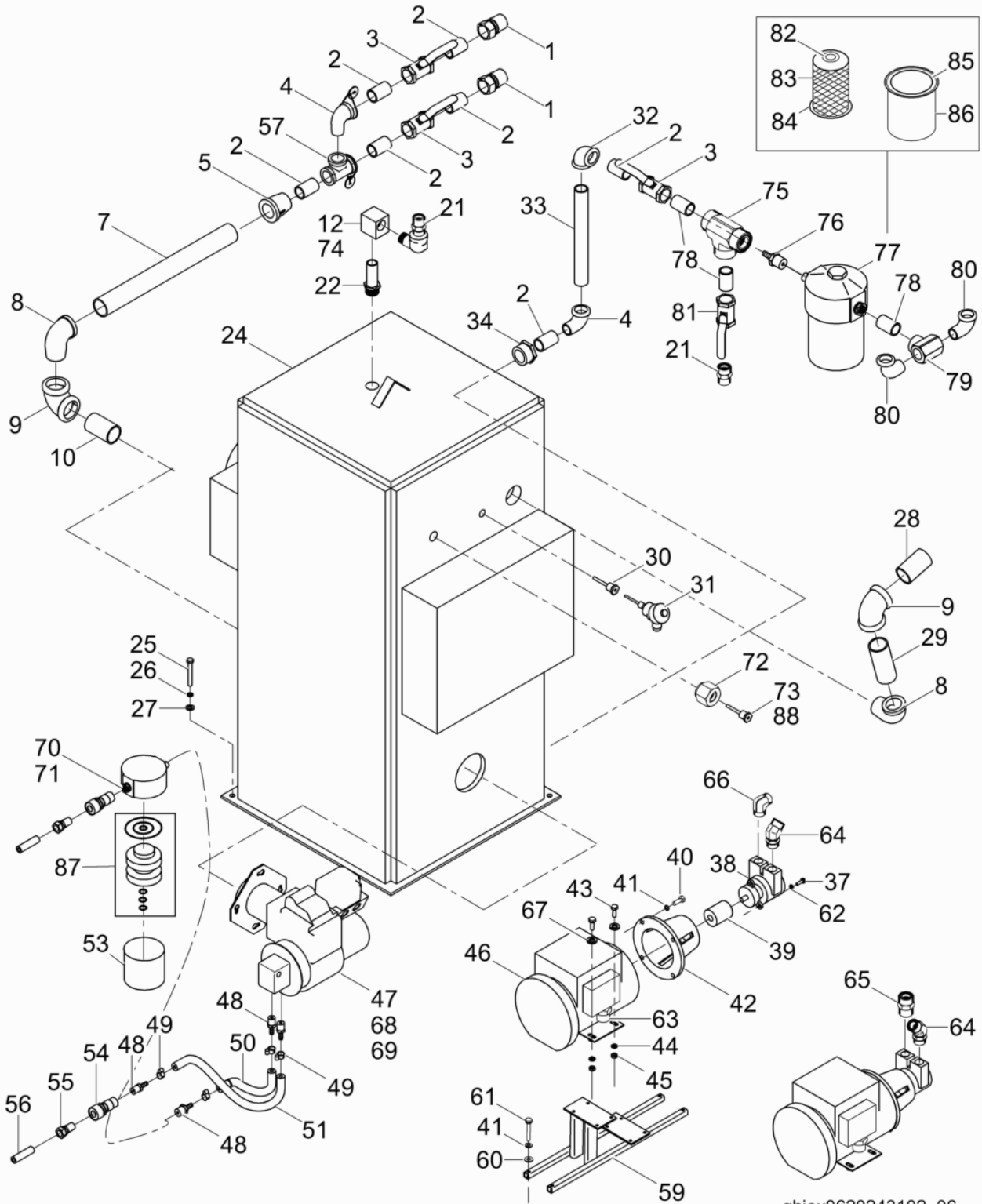

ghiex0620243102_06

Ref. Pos.	Part No. Artikel Nr.	Qty. St.	Description Beschreibung	Descripción Description	Measurem./Abm.	Norm
					Torque/Drehm.	Sealant Schmierstoff
39	0168111	2	Coupling Kupplung	Acoplamiento Accouplement		
40	0167705	8	Bolt Bolzen	Perno Boulon	3/8-16 x 1in	
41	0167735	8	Lock washer Federring	Federring Rondelle de ressort	3/8in	
42	0168110	2	Adapter Adapter	Adaptador Raccord		
43	0167708	8	Bolt Bolzen	Perno Boulon	5/16-18 x 1in	
44	0167736	8	Washer-lock Federring	Arandela elástica Rondelle de ressort	5/16in	
45	0167692	8	Nut Mutter	Tuerca Écrou	5/16in - 18	
46	0168756	2	Motor Motor	Motor Moteur	1/2hp	
47	0168077	1	Burner Brenner	Quemador Brûleur	50Hz	
48	0168284	4	Hose barb Schlauchwiderhaken	Púa de manguera Barbelure de flexible	1/4 x 1/4in	
49	0168334	4	Clamp Schelle	Abrazadera Agrafe		
50	0174002	1	Fuel Hose Kit Kraftstoffleitungssatz	Juego de manguera de combustible. Jeu de tuyau à essence		
51	0170018	1	Fuel return hose Kraftstoffrückleitung	Manguera de combustible de retorno Tuyau à essence de retour		
52	0168044	1	Hose barb Schlauchwiderhaken	Púa de manguera Barbelure de flexible	1/4 x 3/8in	
53	0168078	1	Filter housing Filtergehäuse	Carcasa filtro Filtre		
54	0168294	2	Quick coupler Druckventil	Válvula de presión Soupape de compression		
55	0168295	2	Coupling Kupplung	Acoplamiento Accouplement		
56	0168489	2	Nipple fitting Stutzen	Niple Raccord	1/4 NPT x 2in	
57	0168326	1	Tee-fitting T-Verschraubung	Unión forma T Raccord T	1in NPT	
59	0169779	1	Dual pump mount Doppel-Pumpenkonsole	Montura de bomba doble Support de montage de pompe jumelée		
60	0167729	14	Flat washer Scheibe	Arandela elástica Rondelle de ressort	1/4in	
61	0167703	4	Bolt Bolzen	Perno Boulon	1/4-20 x 1-3/4in	
62	0167733	6	Lock washer Federring	Federring Rondelle de ressort	1/4in	
63	0166458	2	Cord grip Zugentlastung	Alivio de esfuerzos Effort à la décharge	1/2in	
64	0168409	2	Adapter Adapter	Adaptador Raccord		

Heater cpl.
 Heizung, kpl.
 Calentador, acopl.
 Réchauffeur compl.

HSH 650

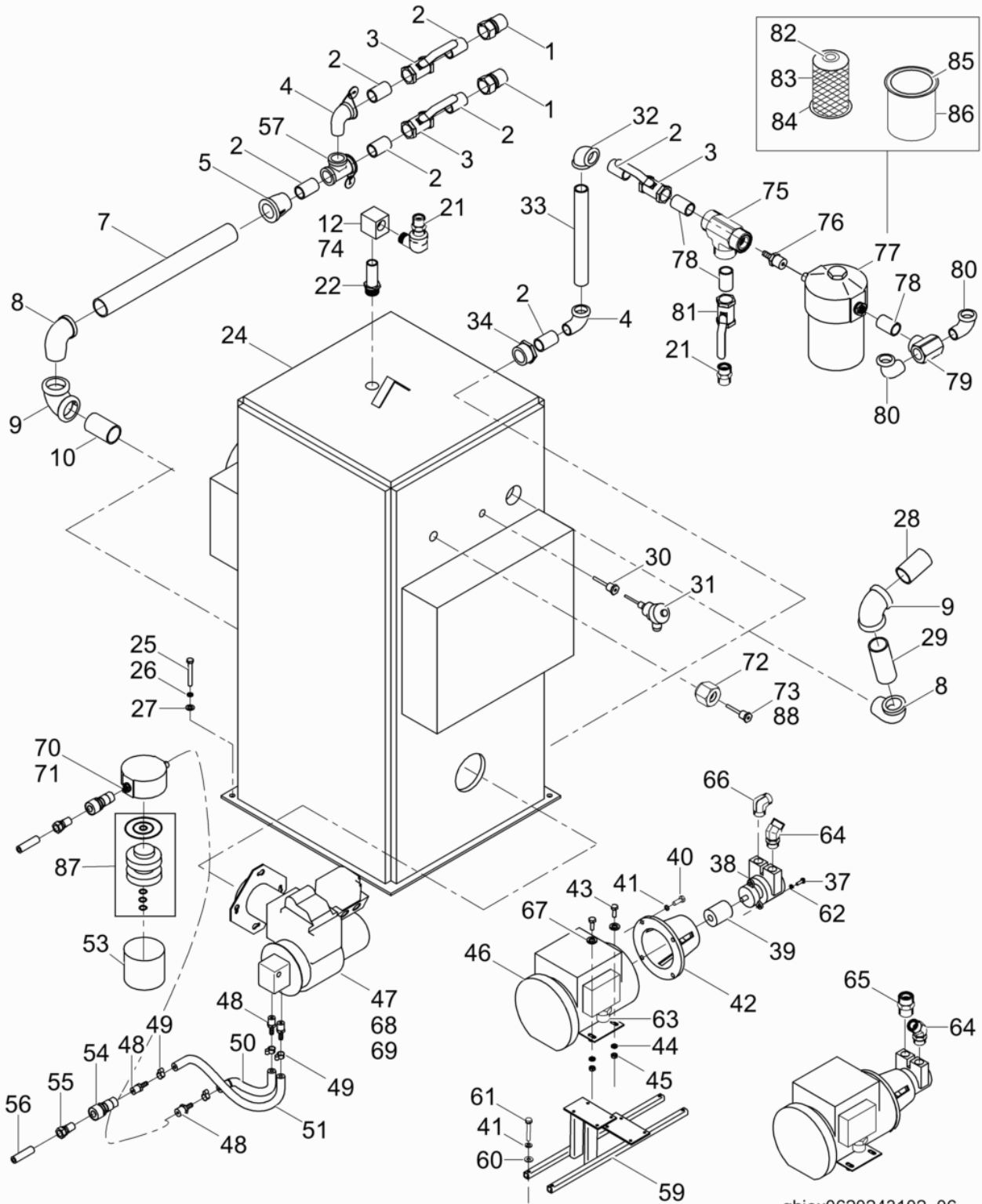

ghiex0620243102_06

Ref. Pos.	Part No. Artikel Nr.	Qty. St.	Description Beschreibung	Descripción Description	Measurem./Abm.	Norm
					Torque/Drehm.	Sealant Schmierstoff
65	0168373	1	Adapter Adapter	Adaptador Raccord	1/2 x 3/4in	
66	0168374	1	Adapter Adapter	Adaptador Raccord		
67	0167731	8	Washer-flat Unterlegscheibe	Arandela plana Rondelle	5/16in	
68	0168774	2	Adapter Adapter	Adaptador Raccord	3/8 x 1/4in	
69	0168773	2	Spacer plates Abstandsplatten	Placas espaciadoras Plaquettes entretoises	25mm	
70	0168034	1	Bushing Buchse	Buje Douille	3/8 x 1/4in	
71	0168062	1	Nipple fitting Stutzen	Niple Raccord	1/4in NPT	
72	0168036	1	Bushing Buchse	Buje Douille	3/4 x 3/8in	
73	0166811	1	Electrode Elektrode	Electrodo Électrode		
74	0165980	1	Cable cpl. Kabel kpl.	Cable compl. Câble compl.		
75	0168406	1	Tee-fitting T-Verschraubung	Unión forma T Raccord T	1 x 1 x 3/4in	
76	0168011	1	Bushing Buchse	Buje Douille	1 x 3/4in	
77	0168297	1	Strainer Sieb	Tamizador Tamis		
78	0168390	3	Nipple fitting Stutzen	Niple Raccord	3/4 x 1-1/2in	
79	0168056	1	Tee-fitting T-Verschraubung	Unión forma T Raccord T	3/4in NPT	
80	0168029	2	Elbow Krümmer	Codo Coude	3/4in NPT	
81	0168256	1	Valve Ventil	Válvula Soupape		
82	0169093	1	Gasket Dichtung	Junta Joint		
83	0169050	1	Filter Filter	Filtro Filtre		
84	0169094	1	Gasket Dichtung	Junta Joint		
85	0169092	1	Gasket Dichtung	Junta Joint		
86	0168297	1	Strainer Sieb	Tamizador Tamis		
87	0168966	1	Filter Element Set Filterelement Satz	Elemento del Filtro Juego Élément du Filtre Jue		
88	0166812	1	Probe Luftklappensonde	Sonda-conjunto del cañón Sonde - ensemble de conduit		

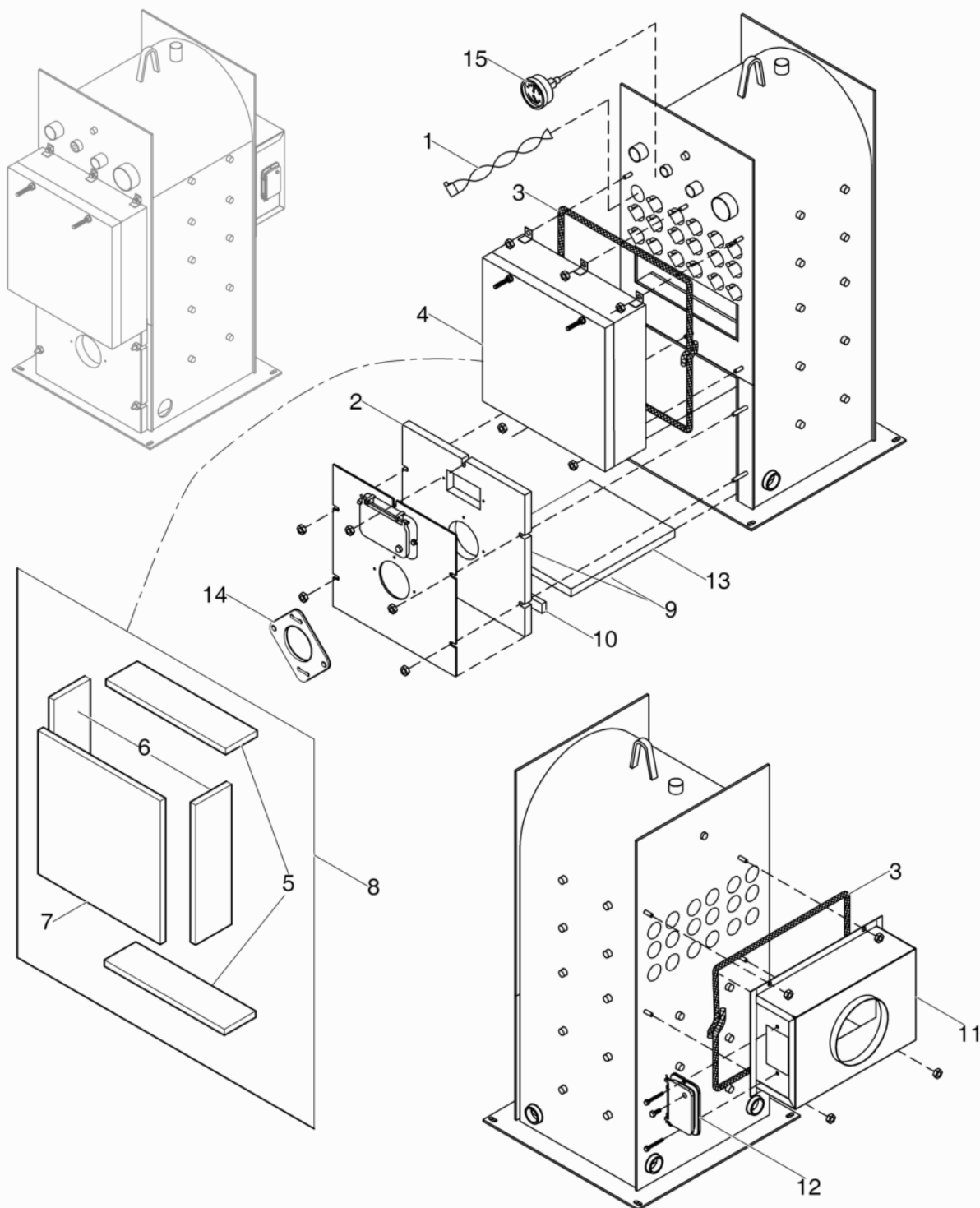

ghiex0168247100_01

Ref. Pos.	Part No. Artikel Nr.	Qty. St.	Description Beschreibung	Descripción Description	Measurem./Abm.	Norm
					Torque/Drehm.	Sealant Schmierstoff
1	0168163	18	Turbulator Turbulator	Turbulator Turboventilateur	19.25 x 1.5	
2	0169029	1	Insulation Isoliermaterial	Aislación Matière isolante		
3	0169159	1	Gasket Dichtung	Junta Joint		
4	0177481	1	Flue box assembly Rauchgas-Box kpl.	Cuadro de combustión compl. Boîte de fumée compl.		
5	0169006	1	Insulation Isoliermaterial	Aislación Matière isolante		
6	0174729	1	Panel Panel	Panel Tableau		
7	0174726	1	Flue box door Rauchabzugskastentür	Puerta de la caja del cañón Porte de cheminée		
8	0177480	1	Insulation Kit Isoliermaterialsatz	Juego de aislación Jeu de matière isolante		
9	0177479	1	Insulation Kit Isoliermaterialsatz	Juego de aislación Jeu de matière isolante		
10	0177478	1	Insulation Isoliermaterial	Aislación Matière isolante		
11	0177477	1	Box Kasten	Caja Boîte		
12	0177476	1	Door Tür	Puerta Porte		
13	0177743	1	Insulation Isoliermaterial	Aislación Matière isolante		
14	0168976	1	Gasket Dichtung	Junta Joint		
15	0168975	1	Gauge Anzeiger	Indicador Indicateur		

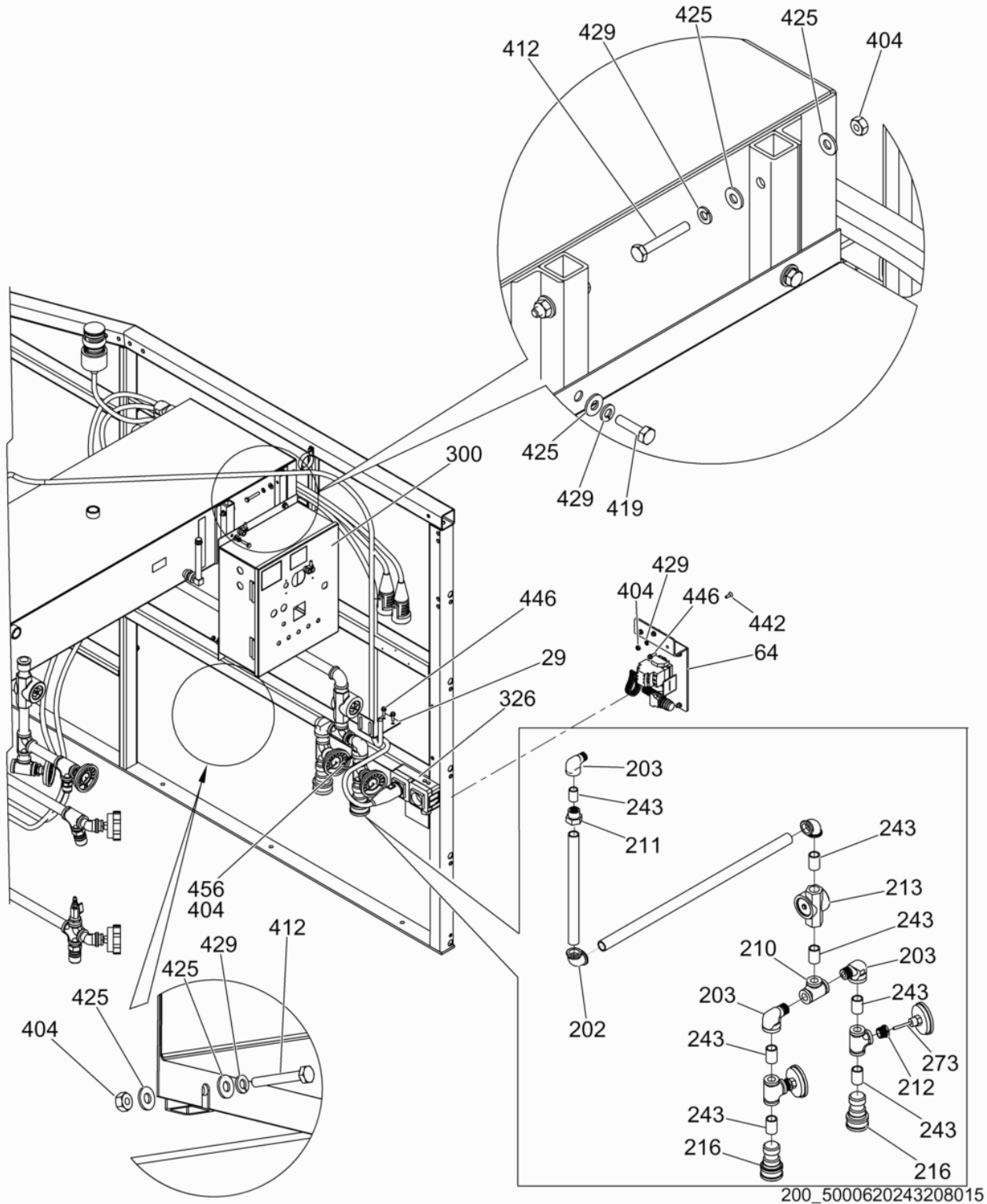

Ref. Pos.	Part No. Artikel Nr.	Qty. St.	Description Beschreibung	Descripción Description	Measurement/Abm.	Norm
					Torque/Drehm.	Sealant Schmierstoff
29	0166905	1	Bracket Konsole	Soporte Support		
202	0168027	2	Elbow Krümmer	Codo Coude	3/4in NPT	
203	0168029	3	Elbow Krümmer	Codo Coude	3/4in NPT	
210	0168056	3	Tee-fitting T-Verschraubung	Unión forma T Raccord T	3/4in NPT	
211	0168058	1	Union Verbindung	Unión Raccord droit	3/4in NPT	
212	0168060	2	Bushing Buchse	Buje Douille	3/4 x 1/2in	
213	0168091	1	Flow indicator Flussanzeiger	Indicador de flujo Débitmètre	3/4in NPT	
216	0168213	2	Quick connect Schnellkupplung	Conexión rápida Branchement rapide	3/4 NPT	
243	0168390	6	Nipple fitting Stutzen	Niple Raccord	3/4 x 1-1/2in	
273	0168096	2	Thermometer Thermometer	Termómetro Thermomètre	1/2 NPT	
300	0166216	1	Control panel cpl. Schalttafel-Anlage kpl.	Conjunto tablero de control compl. Tableau de commande compl.		
326	0166788	1	Electrical box Schaltkasten	Caja eléctrica Coffret électrique		
404	0173144	2	Bracket Konsole	Soporte Support		
404	0167690	6	Nut Mutter	Tuerca Écrou	1/4in - 20	
412	0167703	4	Bolt Bolzen	Perno Boulon	1/4-20 x 1-3/4in	
419	0167721	2	Bolt Bolzen	Perno Boulon	1/4-20 x 1in	
425	0167729	10	Flat washer Scheibe	Arandela elástica Rondelle de ressort	1/4in	
429	0167733	6	Lock washer Federring	Federring Rondelle de ressort	1/4in	
442	0167768	4	Screw Schraube	Tornillo Vis	1/4-20 x 3/4	
446	0167793	5	Screw Schraube	Tornillo Vis	1/4-14 x 3/4in	
456	0167841	1	U-Bolt U-Bolzen	Perno forma U Boulon U	1/4-20 x 2 x 1-1/8	

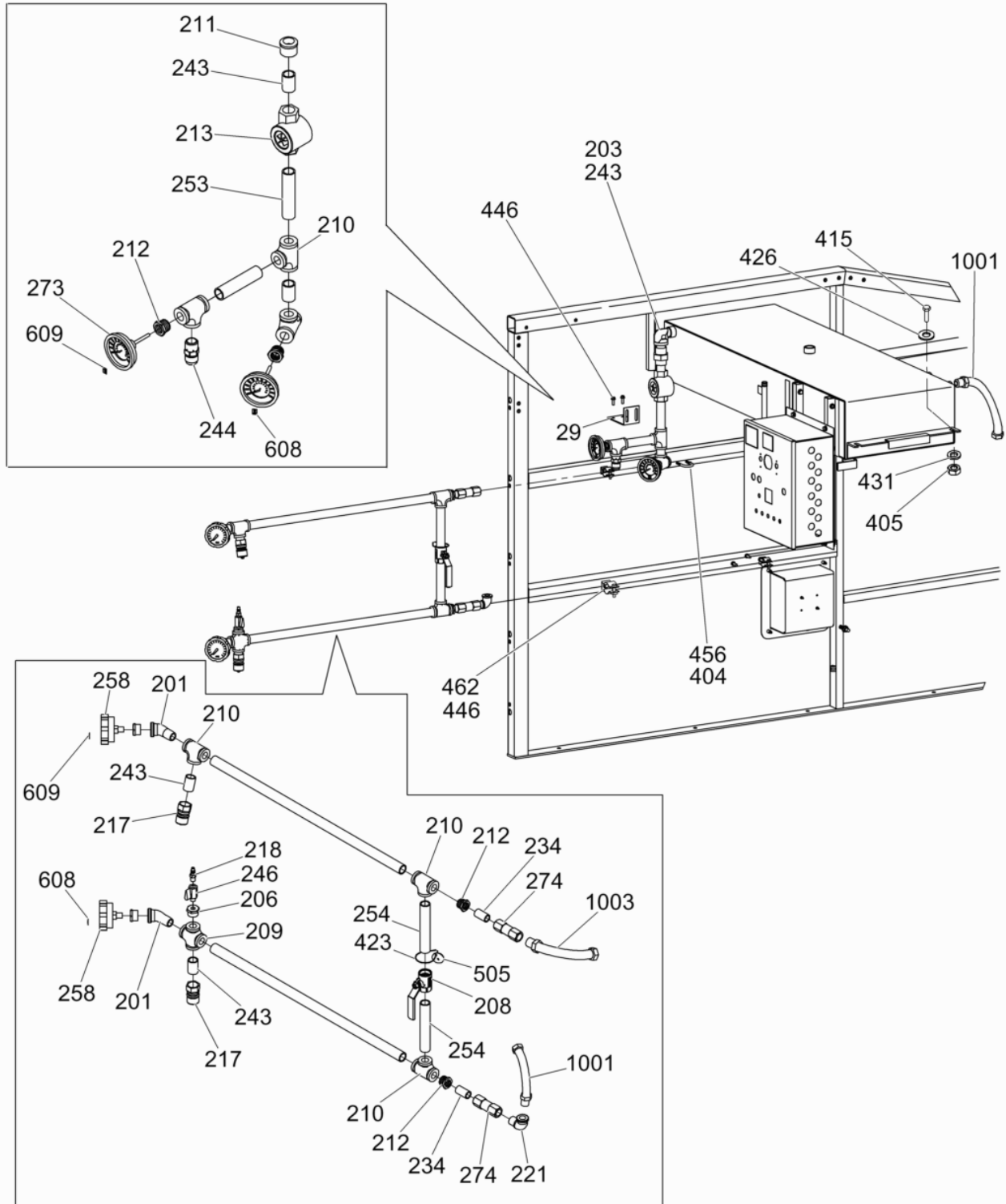

200_5000620243208016

Ref. Pos.	Part No. Artikel Nr.	Qty. St.	Description Beschreibung	Descripción Description	Measurem./Abm.	Norm
					Torque/Drehm.	Sealant Schmierstoff
23	0166131	1	Hose cpl. Schlauch kpl.	Manguera compl. Tuyau compl.		
29	0166905	1	Bracket Konsole	Soporte Support		
201	0168026	2	Elbow Krümmer	Codo Coude	3/4in NPT	
203	0168029	1	Elbow Krümmer	Codo Coude	3/4in NPT	
206	0168035	3	Bushing Buchse	Buje Douille	3/4 x 1/4in	
208	0168050	1	Valve Ventil	Válvula Soupape		
209	0168053	1	Cross Kreuz	Cruz Croisillon	3/4in NPT	
210	0168056	6	Tee-fitting T-Verschraubung	Unión forma T Raccord T	3/4in NPT	
211	0168058	1	Union Verbindung	Unión Raccord droit	3/4in NPT	
212	0168060	4	Bushing Buchse	Buje Douille	3/4 x 1/2in	
213	0168091	1	Flow indicator Flussanzeiger	Indicador de flujo Débitmètre	3/4in NPT	
217	0168218	1	Coupling Kupplung	Acoplamiento Accouplement		
218	0168218	1	Coupling Kupplung	Acoplamiento Accouplement		
221	0168236	1	Elbow Krümmer	Codo Coude	1/2in NPT	
234	0168353	2	Nipple fitting Stutzen	Niple Raccord	1/2 NPT x 1-1/2in	
243	0168390	4	Nipple fitting Stutzen	Niple Raccord	3/4 x 1-1/2in	
244	0168393	1	Adapter Adapter	Adaptador Raccord	3/4 x 3/4in	
246	0168437	1	Hose barb Schlauchwiderhaken	Púa de manguera Barbelure de flexible	5/8 x 3/4in	
253	0168701	2	Nipple fitting Stutzen	Niple Raccord	3/4 x 4-1/2	
254	0168702	2	Nipple fitting Stutzen	Niple Raccord	3/4 x 6in	
258	0168772	2	Gauge-pressure Druckanzeiger	Indicador-presión Manomètre	0-200psi	
273	0168096	2	Thermometer Thermometer	Termómetro Thermomètre	1/2 NPT	
274	0168351	2	Valve-check Rückschlagventil	Válvula checadora Clapet de non-retour	1/2 NPT	
404	0167690	2	Nut Mutter	Tuerca Écrou	1/4in - 20	
405	0167691	4	Nut Mutter	Tuerca Écrou	3/8in - 16	

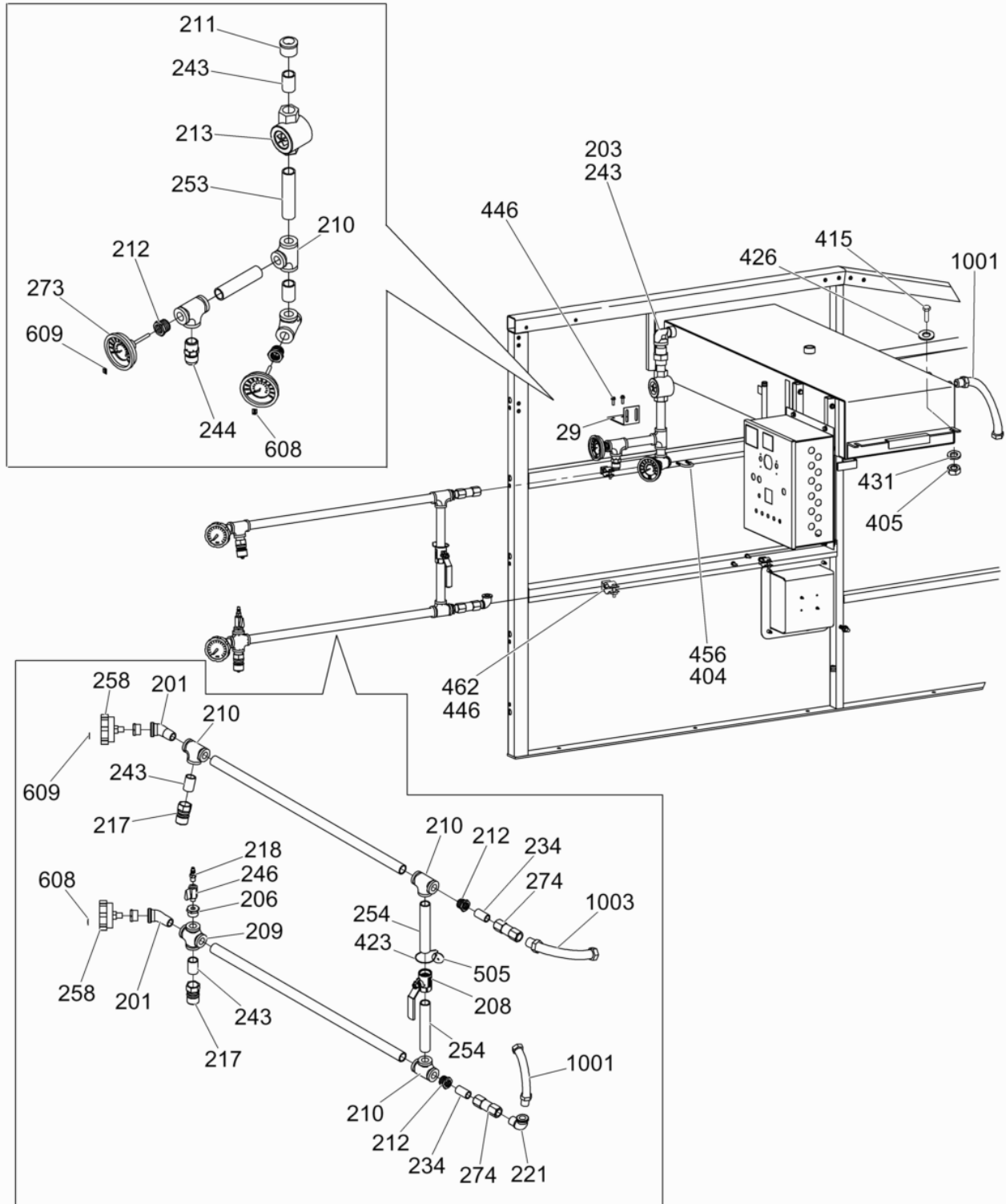

200_5000620243208016

Ref. Pos.	Part No. Artikel Nr.	Qty. St.	Description Beschreibung	Descripción Description	Measurement/Abm.	Norm
					Torque/Drehm.	Sealant Schmierstoff
415	0167706	4	Bolt Bolzen	Perno Boulon	3/8-16 x 3in	
423	0167727	1	Tie wire Bandagendraht	Alambre para ataduras Fil de frettage	8in	
426	0167730	4	Flat washer Scheibe	Arandela elástica Rondelle de ressort	3/8in	
431	0167735	4	Lock washer Federring	Federring Rondelle de ressort	3/8in	
446	0167793	2	Screw Schraube	Tornillo Vis	1/4-14 x 3/4in	
456	0167841	1	U-Bolt U-Bolzen	Perno forma U Boulon U	1/4-20 x 2 x 1-1/8	
462	0168016	4	Conduit hanger Isolierrohrhänger	Colgador de portacables Support de conduit	3/4in	
505	0168189	1	Tag No. 4 Anhängeschild Nr. 4	Etiqueta No. 4 Étiquette No. 4		
608	0168664	1	Label-pump temperature gauge Aufkleber	Calcomania Autocollant		
609	0168663	2	Label-pump temperature gauge Aufkleber	Calcomania Autocollant		
1000	0165978	1	Hose cpl. Schlauch kpl.	Manguera compl. Tuyau compl.	5/8 ID x 23in	
1001	0166221	1	Hose cpl. Schlauch kpl.	Manguera compl. Tuyau compl.		
1003	0166222	1	Hose cpl. Schlauch kpl.	Manguera compl. Tuyau compl.		

Filter cpl.
Filter, kpl.
Filtro, acopl.
Filtre compl.

HSH 650

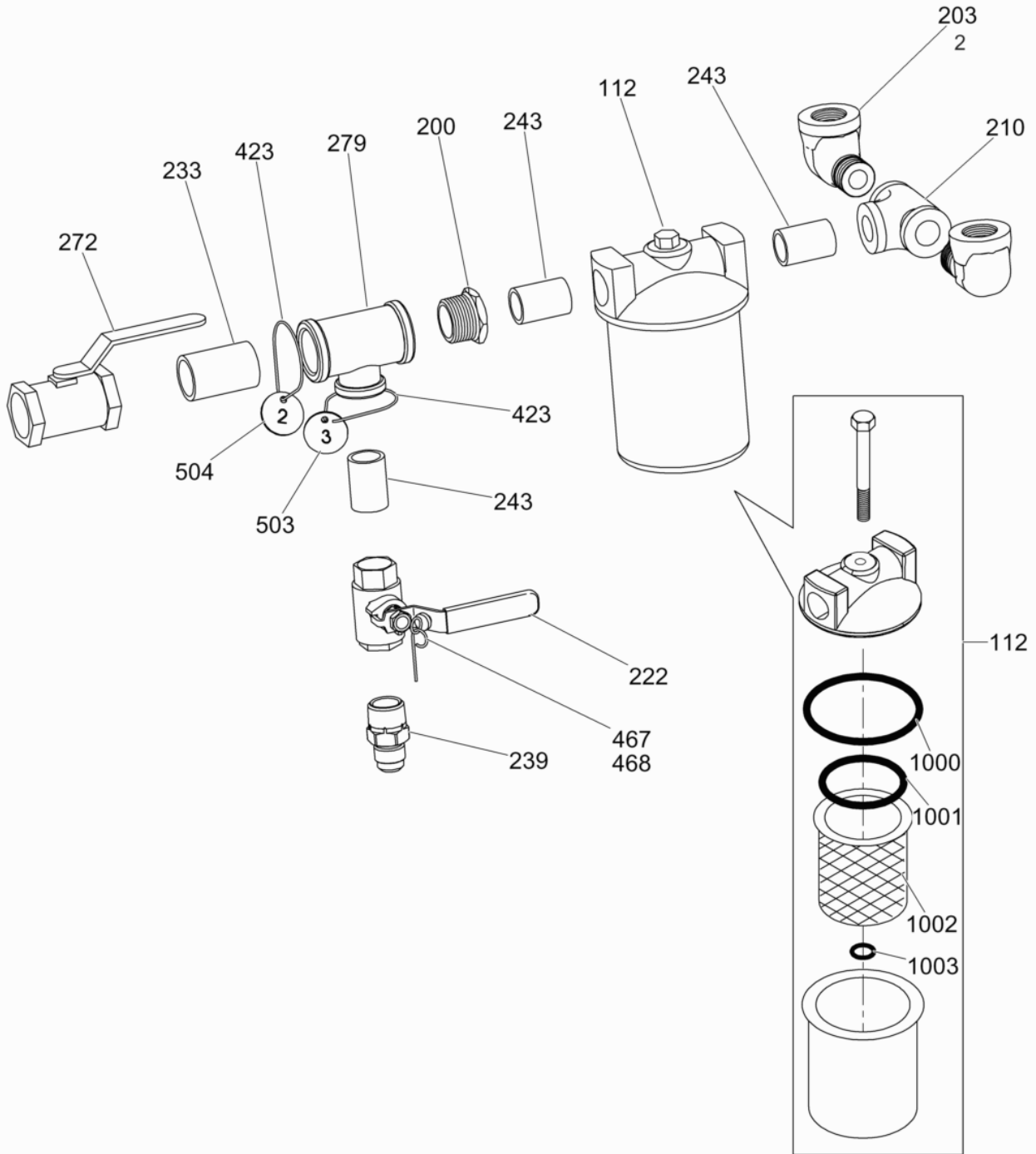

200_5000620243208007

Ref. Pos.	Part No. Artikel Nr.	Qty. St.	Description Beschreibung	Descripción Description	Measurem./Abm.	Norm
					Torque/Drehm.	Sealant Schmierstoff
112	0168297	1	Strainer Sieb	Tamizador Tamis		
200	0168011	1	Bushing Buchse	Buje Douille	1 x 3/4in	
203	0168029	2	Elbow Krümmer	Codo Coude	3/4in NPT	
210	0168056	1	Tee-fitting T-Verschraubung	Unión forma T Raccord T	3/4in NPT	
222	0168256	1	Valve Ventil	Válvula Soupape		
233	0168331	1	Nipple fitting Stutzen	Niple Raccord	1 NPT x 2in	S22
239	0168372	1	Adapter Adapter	Adaptador Raccord	3/4 x 5/8in	
243	0168390	3	Nipple fitting Stutzen	Niple Raccord	3/4 x 1-1/2in	S22
272	0168330	1	Valve Ventil	Válvula Soupape		
279	0168406	1	Tee-fitting T-Verschraubung	Unión forma T Raccord T	1 x 1 x 3/4in	
423	0167727	1	Tie wire Bandagendraht	Alambre para ataduras Fil de fretage	8in	
426	0167727	1	Tie wire Bandagendraht	Alambre para ataduras Fil de fretage	8in	
467	0168257	1	Pin Stift	Pasador Goupille		
468	0168262	1	Lanyard Abzugsleine	Correa Ridoir	10in	
503	0168188	1	Tag No. 3 Anhängeschild Nr. 3	Étiquette No. 3		
504	0168187	1	Tag No. 2 Anhängeschild Nr. 2	Étiquette No. 2		
1000	0169092	1	Gasket Dichtung	Junta Joint		
1001	0169094	1	Gasket Dichtung	Junta Joint		
1002	0169050	1	Filter Filter	Filtro Filtre		
1003	0169093	1	Gasket Dichtung	Junta Joint		

Fuel Filter
Kraftstofffilter
Filtro de Combustible
Filtre à Carburant

HSH 650

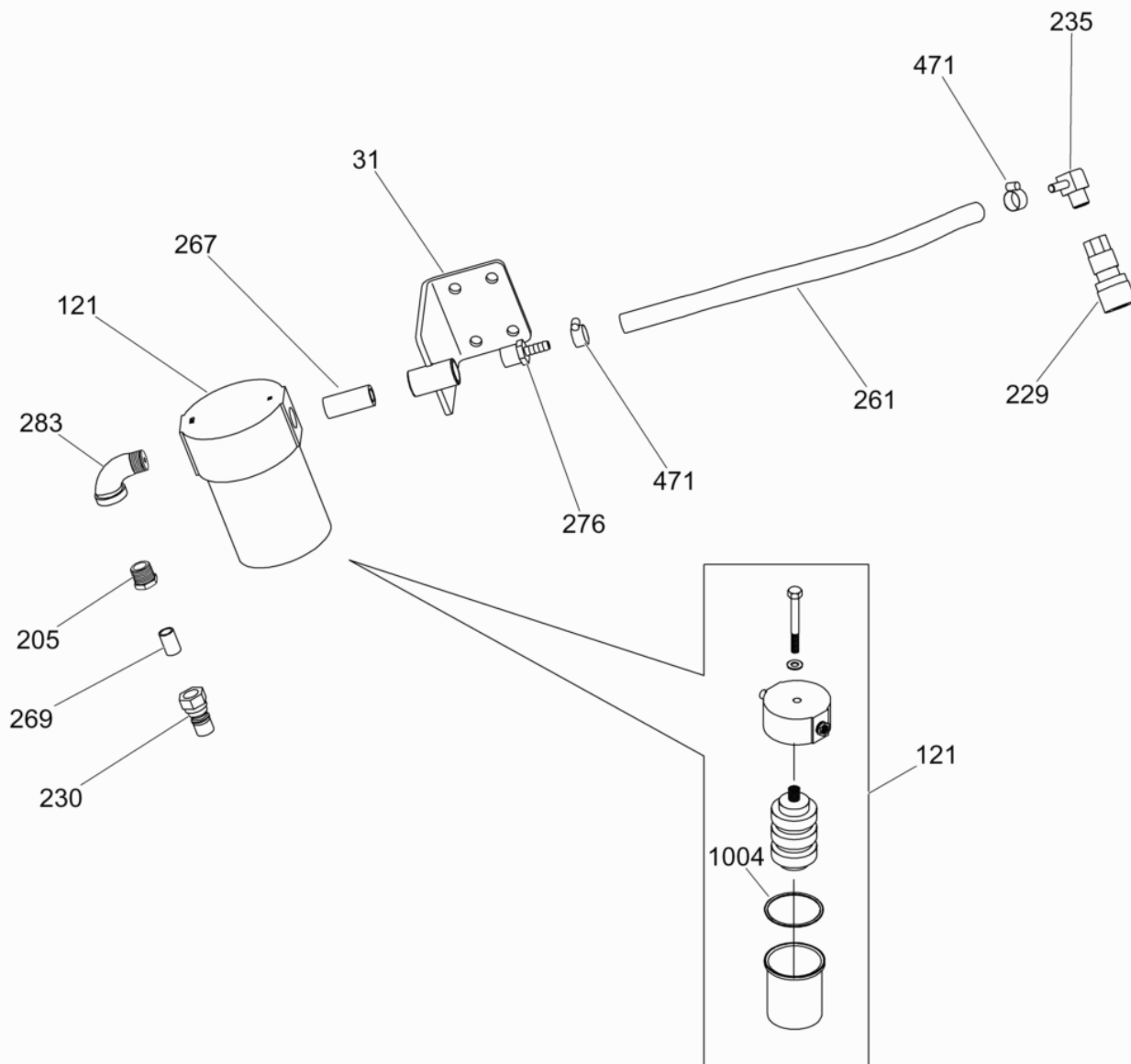

200_5000620243208008

Ref. Pos.	Part No. Artikel Nr.	Qty. St.	Description Beschreibung	Descripción Description	Measurement/Abm.	Norm
					Torque/Drehm.	Sealant Schmierstoff
31	0169552	1	Fuel filter mounting plate Kraftstofffilter Montageplatte	Placa de montaje del filtro de combustible Filtre à carburant		
121	0168078	1	Filter housing Filtergehäuse	Carcasa filtro Filtre		
205	0168034	1	Bushing Buchse	Buje Douille	3/8 x 1/4in	
229	0168294	1	Quick coupler Druckventil	Válvula de presión Soupape de compression		
230	0168295	1	Coupling Kupplung	Acoplamiento Accouplement		
235	0168367	1	Hose barb Schlauchwiderhaken	Púa de manguera Barbelure de flexible	1/4 x 1/4in	S22
261	0169397	1	Hose Schlauch	Manguera Tuyau	1/4in ID	
267	0168073	1	Nipple fitting Stutzen	Niple Raccord	3/8in NPT	S22
269	0168062	1	Nipple fitting Stutzen	Niple Raccord	1/4in NPT	S22
276	0168044	1	Hose barb Schlauchwiderhaken	Púa de manguera Barbelure de flexible	1/4 x 3/8in	
283	0171287	1	Elbow Krümmer	Codo Coude	3-8 NPT	
471	0168334	1	Clamp Schelle	Abrazadera Agrafe		
1004	0168966	1	Filter Element Set Filterelement Satz	Elemento del Filtro Juego Élément du Filtre Jue		

Motor/Pump cpl.
Motorpumpe, kpl.
Motor bomba, acopl.
Moteur, pompe compl.

HSH 650

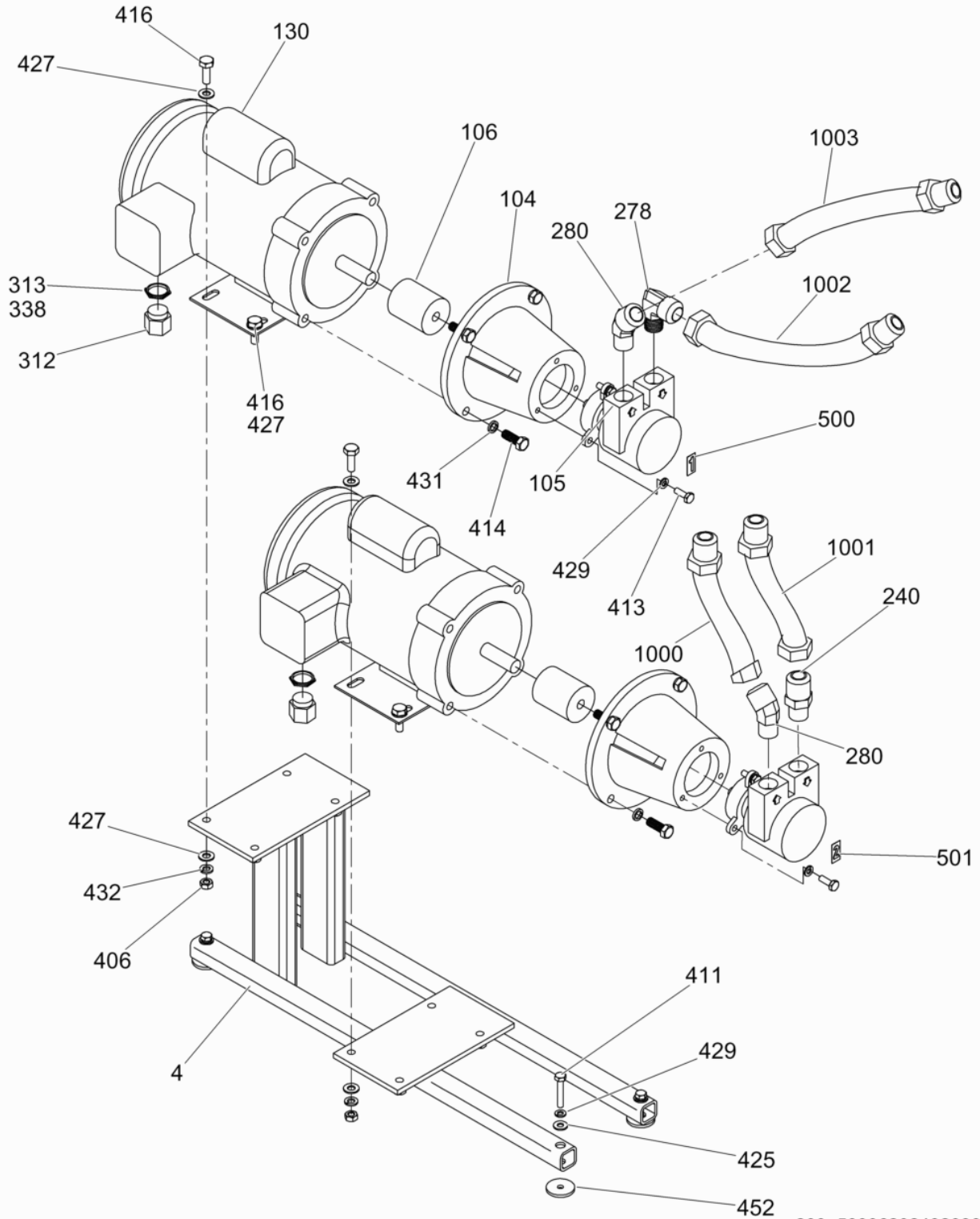

200_5000620243208011

Ref. Pos.	Part No. Artikel Nr.	Qty. St.	Description Beschreibung	Descripción Description	Measurem./Abm.	Norm
					Torque/Drehm.	Sealant Schmierstoff
4	0169779	1	Dual pump mount Doppel-Pumpenkonsole	Montura de bomba doble Support de montage de pompe jumelée		
104	0168110	2	Adapter Adapter	Adaptador Raccord		
105	0168277	2	Pump Pumpe	Bomba Pompe	265gph	
106	0168111	2	Coupling Kupplung	Acoplamiento Accouplement		
130	0168756	2	Motor Motor	Motor Moteur	1/2hp	
240	0168373	1	Adapter Adapter	Adaptador Raccord	1/2 x 3/4in	
278	0168374	1	Adapter Adapter	Adaptador Raccord		
280	0168409	2	Adapter Adapter	Adaptador Raccord		
312	0166459	2	Lock nut Sicherungsmutter	Contratuercas Contre-écrou		
313	0166459	2	Lock nut Sicherungsmutter	Contratuercas Contre-écrou		
338	0166833	3	Terminal Anschlußklemme	Terminal de conexión Borne d'attache	12-28 GA	
406	0167692	8	Nut Mutter	Tuerca Écrou	5/16in - 18	
411	0167702	1	Bolt Bolzen	Perno Boulon	1/4-20 x 1-1/2in	
413	0167704	6	Bolt Bolzen	Perno Boulon	1/4-20 x 3/4in	
414	0167705	8	Bolt Bolzen	Perno Boulon	3/8-16 x 1in	
416	0167708	8	Bolt Bolzen	Perno Boulon	5/16-18 x 1in	
425	0167729	1	Flat washer Scheibe	Arandela elástica Rondelle de ressort	1/4in	
427	0167731	16	Washer-flat Unterlegscheibe	Arandela plana Rondelle	5/16in	
429	0167733	1	Lock washer Federring	Federring Rondelle de ressort	1/4in	
431	0167735	8	Lock washer Federring	Federring Rondelle de ressort	3/8in	
432	0167736	8	Washer-lock Federring	Arandela elástica Rondelle de ressort	5/16in	
452	0167833	1	Fender washer Unterlegscheibe	Arandela Rondelle	1/4 x 1-1/4	
500	0168626	11	Label Aufkleber	Calcomania Autocollant		
501	0168627	1	Label Aufkleber	Calcomania Autocollant		
1000	0166221	1	Hose cpl. Schlauch kpl.	Manguera compl. Tuyau compl.		

Motor/Pump cpl.
Motorpumpe, kpl.
Motor bomba, acopl.
Moteur, pompe compl.

HSH 650

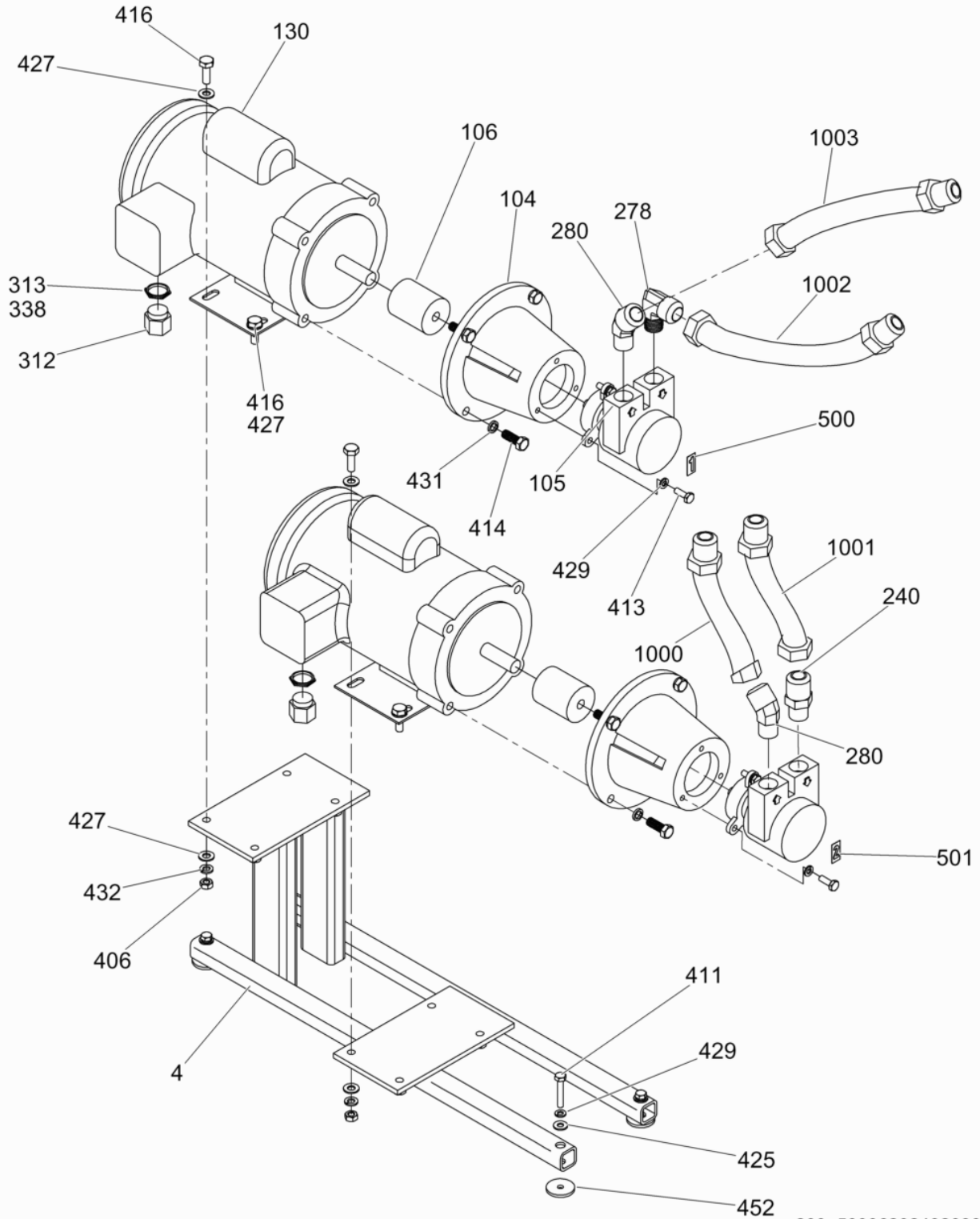

200_5000620243208011

Ref. Pos.	Part No. Artikel Nr.	Qty. St.	Description Beschreibung	Descripción Description	Measurem./Abm.	Norm
					Torque/Drehm.	Sealant Schmierstoff
1001	0166220	1	Hose cpl. Schlauch kpl.	Manguera compl. Tuyau compl.		
1002	0166219	1	Hose cpl. Schlauch kpl.	Manguera compl. Tuyau compl.		
1003	0166222	1	Hose cpl. Schlauch kpl.	Manguera compl. Tuyau compl.		

Hose Reel cpl.
Schlauchhaspel, kpl.

HSH 650

Carrete de la manguera compl.
Dévidoir enrouleur compl.

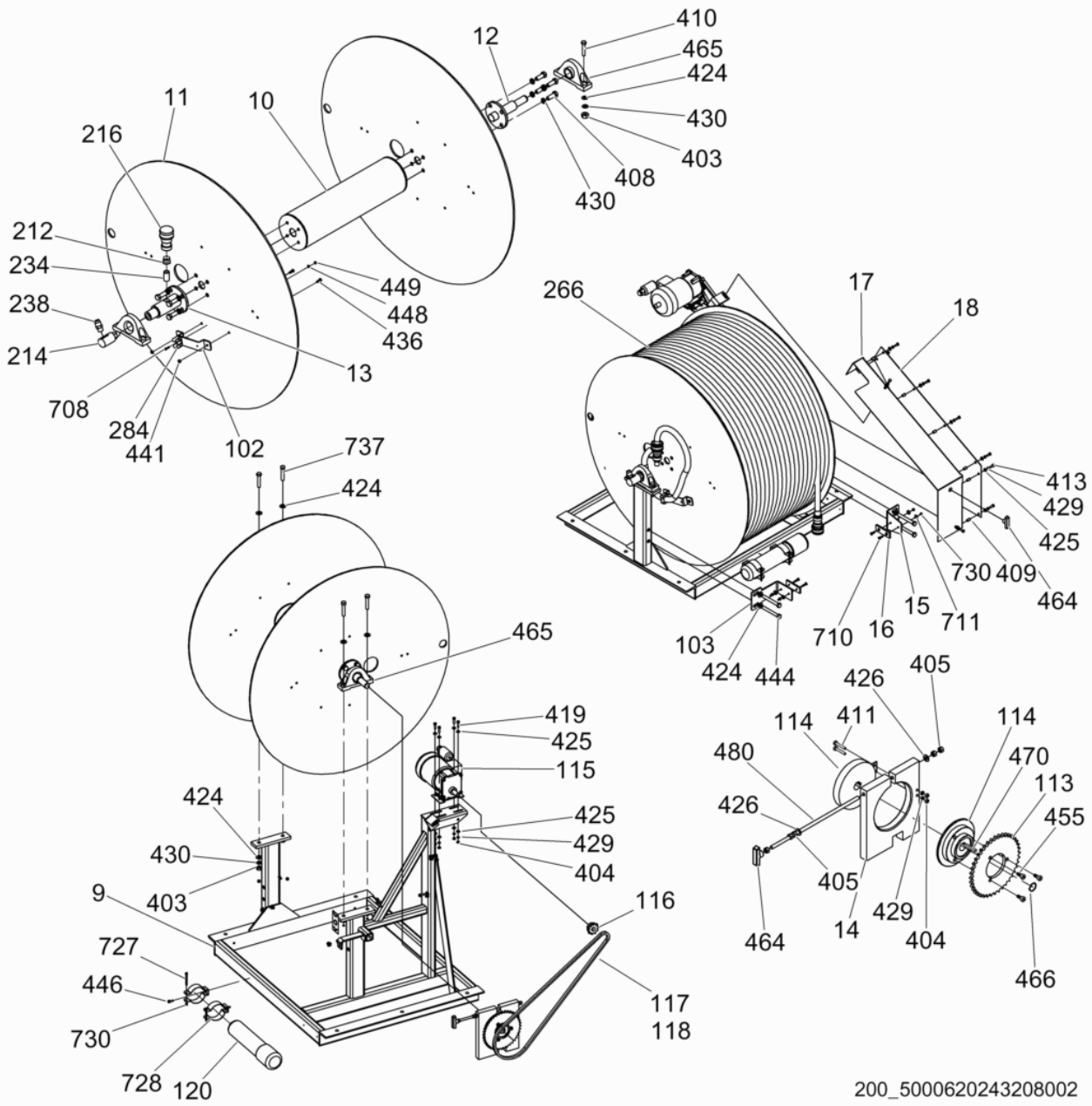
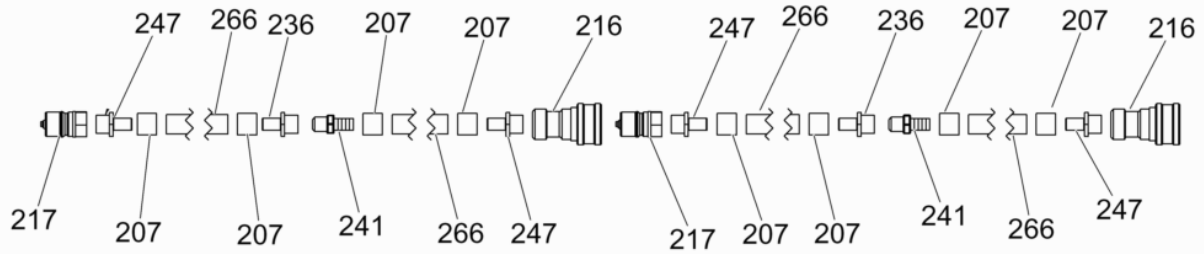

200_5000620243208002

Ref. Pos.	Part No. Artikel Nr.	Qty. St.	Description Beschreibung	Descripción Description	Measurement./Abm.	Norm
					Torque/Drehm.	Sealant Schmierstoff
9	0169563	1	Frame Rahmen	Chasis Châssis		
10	0169880	1	Spool cpl. Spule, kpl.	Bobina, acopl. Bobine compl.		
11	0167629	2	Spool disc Spulenscheibe	Disco de la bobina Disque à bobine	1/4 x 42in	
12	0169459	1	Spindle Spindel	Husillo Broche		
13	0169683	1	Spindle Spindel	Husillo Broche		
14	0166902	1	Brake Bremse	Freno Frein		
15	0180024	1	Bracket Konsole	Soporte Support		
16	0180001	2	Shim Ausgleichscheibe	Laminita Cale		
17	0167120	1	Chain guard Kettenschutz	Protección de la cadena Carter de chaîne		
18	0167121	1	Chain guard cover Kettenschutzabdeckung	Cubierta, protección de la cadena Plaque de carter de chaîne		
102	0176405	1	Bracket Konsole	Soporte Support		
103	0180023	1	Bracket Konsole	Soporte Support		
113	0166894	1	Sprocket Kettenrad	Rueda de cadena Pignon à chaîne		
114	0168104	2	Clutch Kupplung	Embrague Embrayage		
115	0168755	1	Gear Zahnrad	Engranaje Engrenage		
116	0168107	1	Sprocket Kettenrad	Rueda de cadena Pignon à chaîne		
117	0168075	1	Chain Kette	Cadena Chaîne		
118	0168076	1	Chain Kette	Cadena Chaîne		
120	5200000929	1	Manual holder Handbuchhalter	Soporte manual Support de manuel		
207	0168042	8	Hose ferrule Schlauchzwinge	Férula de manguera Bague de flexible	0.975in ID	
212	0168060	1	Bushing Buchse	Buje Douille	3/4 x 1/2in	
214	0168109	1	Swivel Drehung	Unión giratoria Pivot	1/2 x 1/2	
216	0168213	3	Quick connect Schnellkupplung	Conexión rápida Branchement rapide	3/4 NPT	
217	0168214	2	Quick connect Schnellkupplung	Conexión rápida Branchement rapide	3/4in NPT	
234	0168353	1	Nipple fitting Stutzen	Niple Raccord	1/2 NPT x 1-1/2in	

Hose Reel cpl.
Schlauchhaspel, kpl.

HSH 650

Carrete de la manguera compl.
Dévidoir enrouleur compl.

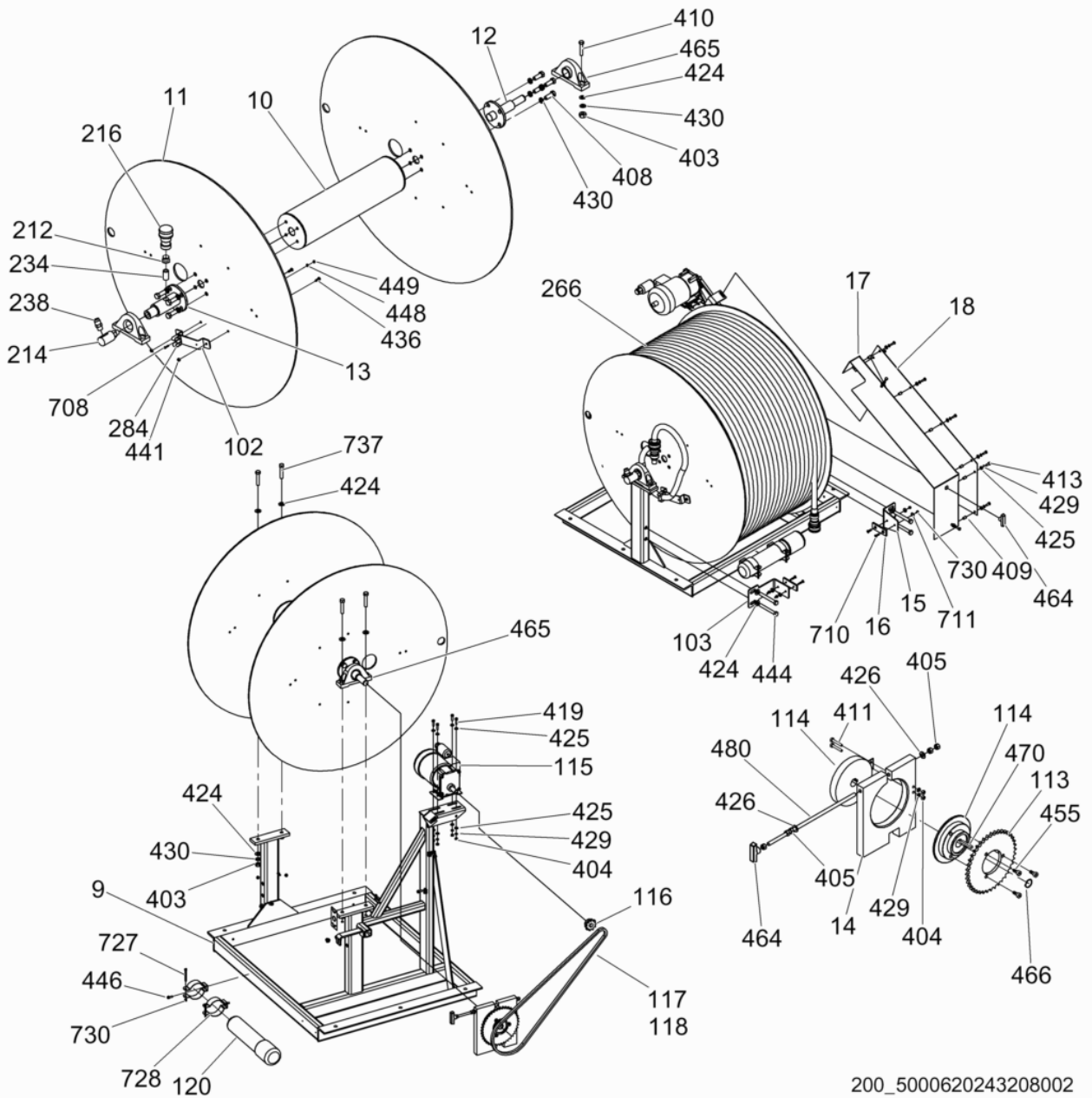
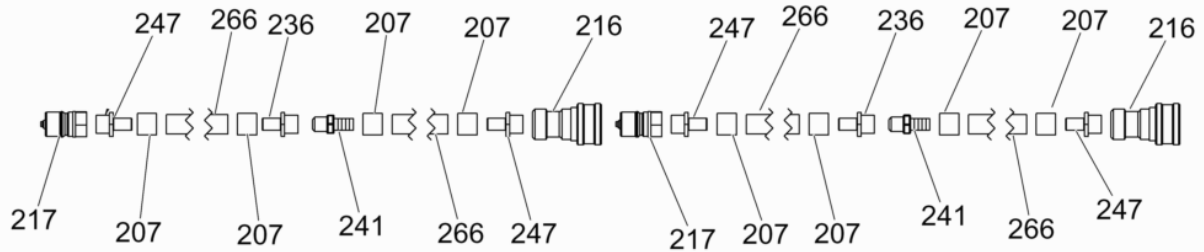

200_5000620243208002

Ref. Pos.	Part No. Artikel Nr.	Qty. St.	Description Beschreibung	Descripción Description	Measurement/Abm.	Norm
					Torque/Drehm.	Sealant Schmierstoff
236	0168369	2	Hose barb Schlauchwiderhaken	Púa de manguera Barbelure de flexible	5/8 x 5/8in	
238	0168371	1	Adapter Adapter	Adaptador Raccord	1/2 x 5/8in	
241	0168376	2	Hose end Schlauchende	Extremo de manguera Extrémité de flexible	5/8 x 5/8in	S3
247	0168437	4	Hose barb Schlauchwiderhaken	Púa de manguera Barbelure de flexible	5/8 x 3/4in	
266	0169435	4	Hose Schlauch	Manguera Tuyau	200psi	
284	0153747	1	Clip Befestigung	Clip Clip		
403	0167689	4	Nut Mutter	Tuerca Écrou	1/2in - 13	
404	0167690	6	Nut Mutter	Tuerca Écrou	1/4in - 20	
405	0167691	3	Nut Mutter	Tuerca Écrou	3/8in - 16	
408	0167699	8	Bolt Bolzen	Perno Boulon	1/2-13 x 1-1/2in	
409	0167700	7	Threaded insert Gewindeeinsatz	Inserción roscada Pièce d'insertion filetée	1/4-20	
410	0167701	4	Bolt Bolzen	Perno Boulon	1/2-3 x 2in	
411	0167702	2	Bolt Bolzen	Perno Boulon	1/4-20 x 1-1/2in	
413	0167704	7	Bolt Bolzen	Perno Boulon	1/4-20 x 3/4in	
419	0167721	4	Bolt Bolzen	Perno Boulon	1/4-20 x 1in	
424	0167728	12	Flat washer Scheibe	Arandela elástica Rondelle de ressort	1/2in	
425	0167729	19	Flat washer Scheibe	Arandela elástica Rondelle de ressort	1/4in	
426	0167730	2	Flat washer Scheibe	Arandela elástica Rondelle de ressort	3/8in	
429	0167733	13	Lock washer Federring	Federring Rondelle de ressort	1/4in	
430	0167734	12	Lock washer Federring	Federring Rondelle de ressort	1/2in	
436	0167747	2	Screw Schraube	Tornillo Vis	1/4-20 x 3/4	
441	0167767	2	Nut Mutter	Tuerca Écrou	1/4in - 20	
444	0167781	4	Bolt Bolzen	Perno Boulon	1/2-13 x 4in	
446	0167793	2	Screw Schraube	Tornillo Vis	1/4-14 x 3/4in	
448	0167810	1	Washer-flat Unterlegscheibe	Arandela plana Rondelle	No. 8	

Hose Reel cpl.
Schlauchhaspel, kpl.

HSH 650

Carrete de la manguera compl.
Dévidoir enrouleur compl.

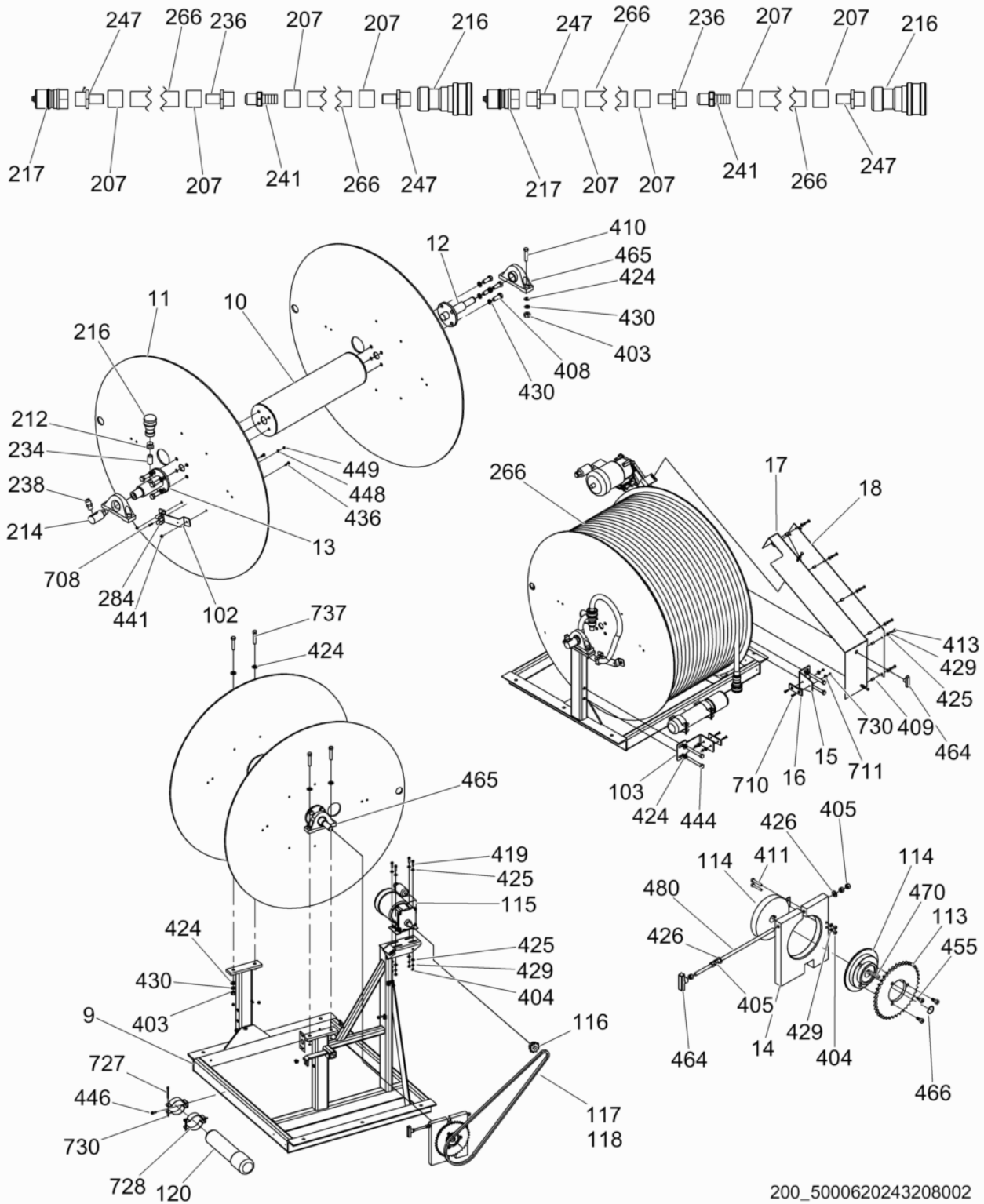

200_5000620243208002

Ref. Pos.	Part No. Artikel Nr.	Qty. St.	Description Beschreibung	Descripción Description	Measurement./Abm.	Norm
					Torque/Drehm.	Sealant Schmierstoff
449	0167814	1	Nut Mutter	Tuerca Écrou	8-32	
455	0167840	3	Screw Schraube	Tornillo Vis	3/8 x 1/4	
464	0168100	1	Knob Griff	Empuñadura Poignée		
465	0168103	2	Bearing Lager	Rodamiento Roulement	11Nm/8ft.lbs	
466	0168106	1	Retaining ring Sicherungsring	Anillo de retención Bague d'arrêt	1 x 0.94	
470	0168292	1	Square key Passfeder	Chaveta Clavette	1/4 x 1/4 x 1-7/8in	
480	0169385	1	Rod Stange	Varilla Tringle	3/8-16 x 6ft	
708	0167813	1	Screw Schraube	Tornillo Vis	No. 8-32 x 3/4	
710	0179351	4	Flat head screw Senkschraube	Tornillo de cabeza perdida Vis à tête conique	M6 x 1	
711	0010624	4	Flat washer Scheibe	Arandela elástica Rondelle de ressort	B6,4	DIN 125
727	5200000928	2	Hex head screw Schraube	Tornillo Vis	M6 X 60	
728	5200000960	2	Clamp Schelle	Abrazadera Agrafe	2-7/8in	
730	0010368	6	Lock nut Sicherungsmutter	Contratuerca Contre-écrou	M6	DIN 985
737	0170246	4	Bolt Bolzen	Perno Boulon	1/2-13 x 2.5 99Nm/73ft.lbs	

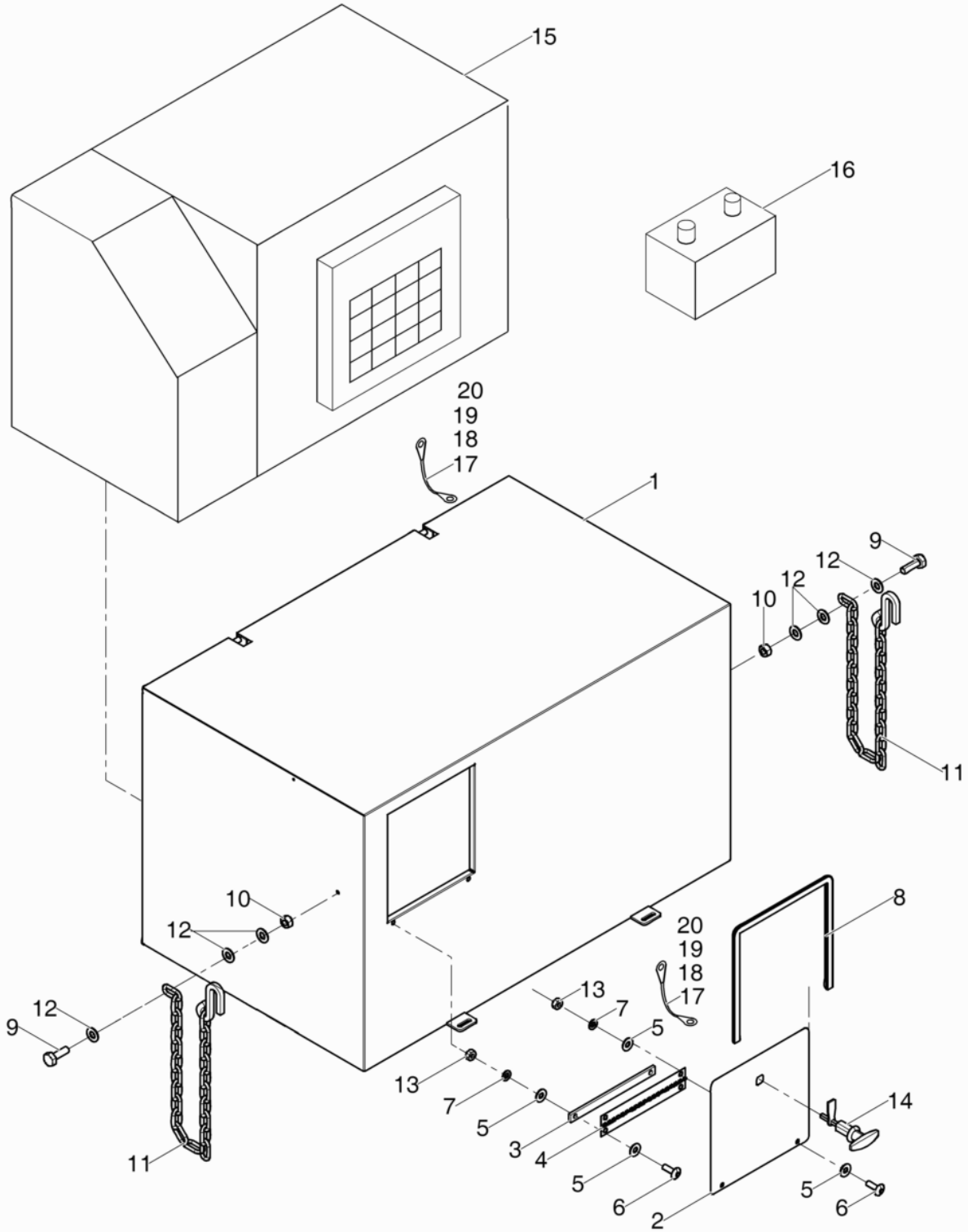

ghiex0620243202_09

Ref. Pos.	Part No. Artikel Nr.	Qty. St.	Description Beschreibung	Descripción Description	Measurem./Abm.	Norm
					Torque/Drehm.	Sealant Schmierstoff
1	0189218	3	Cover cpl. Deckel kpl.	Tapa compl. Couvercle compl.		
2	0174005	1	Door Tür	Puerta Porte		
3	0166950	1	Spacer Abstandsstück	Espaciador Entretoise		
4	0166948	1	Hinge Scharnier	Bisagra Charnière		
5	0167729	8	Flat washer Scheibe	Arandela elástica Rondelle de ressort	1/4in	
6	0167857	4	Screw Schraube	Tornillo Vis	1/4-20 x 3/4	
7	0167733	4	Lock washer Federring	Federring Rondelle de ressort	1/4in	
8	0168354	3	Trim Einfassung	Protección Garniture	12ft	
9	0167708	2	Bolt Bolzen	Perno Boulon	5/16-18 x 1in	
10	0167694	2	Nut Mutter	Tuerca Écrou	5/16-18	
11	0168312	2	Safety chain set Sicherheitskettensatz	Juego de cadenas de seguridad Jeu de chaîne de sûreté	3/16 x 48	
12	0167731	6	Washer-flat Unterlegscheibe	Arandela plana Rondelle	5/16in	
13	0167690	4	Nut Mutter	Tuerca Écrou	1/4in - 20	
14	0174008	1	Handle Handgriff	Manija Poignée		
15	0176370	1	Generator Generator	Generador Générateur		
16	0165552	1	Battery Batterie	Batería Batterie	12V	
17	0177336	2	Ground wire Erdungsdraht	Alambre a tierra Fil de masse		
18	0167819	3	Screw Schraube	Tornillo Vis	10-32 x 3/4	
19	0181623	3	Washer Scheibe	Arandela Rondelle	No.10	
20	0181624	3	Nut Mutter	Tuerca Écrou	No.10	

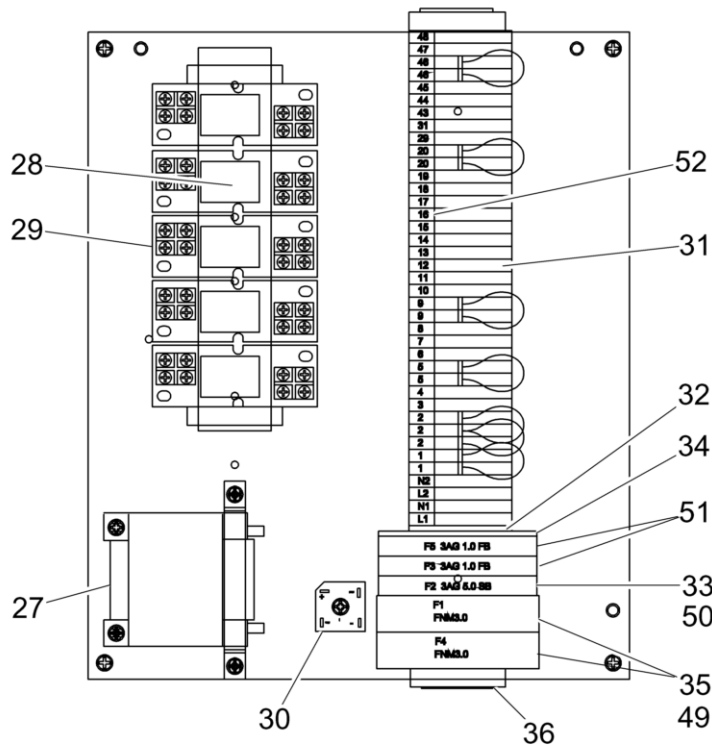
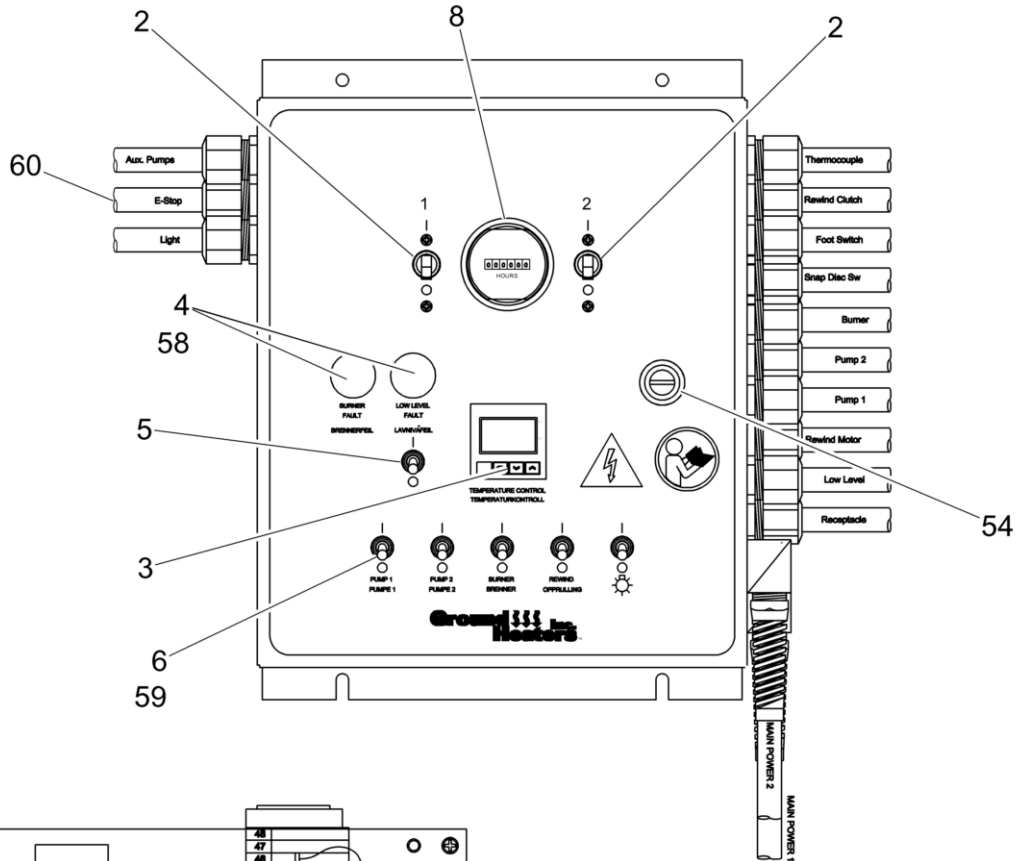

wcghiex0620195100_10

Ref. Pos.	Part No. Artikel Nr.	Qty. St.	Description Beschreibung	Descripción Description	Measur./Abm.	Norm
					Torque/Drehm.	Sealant Schmierstoff
2	0172036	2	Breaker Unterbrecher	Interruptor Disjoncteur		
3	0170275	1	Temperature control Temperaturregelung	Control de temperatura Commande de température		
4	0172037	2	Light-pilot Pilotlicht	Luz piloto Lampe - pilote	220V	
5	0172038	1	Toggle switch Kipphebelschalter	Interruptor de volquete Interrupteur de bascule		
6	0172039	3	Toggle switch Kipphebelschalter	Interruptor de volquete Interrupteur de bascule		
8	0172040	1	Meter-hour Stundenzähler	Medidor-hora Compteur horaire	220V	
27	0166560	1	Transformer Transformator	Transformador Transformateur	120/12.6V	
28	0172041	5	Socket Socket	Tomacorriente Douille		
29	0172042	5	Socket Socket	Tomacorriente Douille		
30	0166564	1	Rectifier Gleichrichter	Rectificador Rectificateur	25A	
31	0166696	39	Terminal block Anschlussblock	Bloque terminal Borne serre-fils	0.25	
32	0171313	1	Terminal-end plate Anschlussklemme	Terminal de conexión Cosse terminale		
33	0172043	3	Fuse Sicherung	Fusible Fusible	300V	
34	0177097	1	End plate fuse Endplattensicherung	Placa extrema fusible Plaque d'extrémité fusible		
35	0166625	2	Fuse block Sicherungsblock	Bloque de fusibles Bloc-fusible		
36	0170668	4	Terminal block end Anschlussblockende	Extremo Fin de bloc terminal		
49	0166709	2	Fuse Sicherung	Fusible Fusible	13/32 x 1.5	
50	0166693	1	Fuse Sicherung	Fusible Fusible	5A	
51	0166814	2	Fuse Sicherung	Fusible Fusible	1A	
52	0171314	39	Terminal-marker Anschlussklemme	Terminal de conexión Cosse terminale		
54	0168001	1	Latch Verriegelung	Aldaba Loquet		
58	0172047	2	Light-bulb Glühbirne	Bombilla Ampoule	220V	
59	0172048	6	Toggle switch Kipphebelschalter	Interruptor de volquete Interrupteur de bascule		
60	0183799	1	Cable Kabel	Cable Câble		

Burner cpl.
Brenner, kpl.
Quemador, acopl.
Brûleur compl.

HSH 650

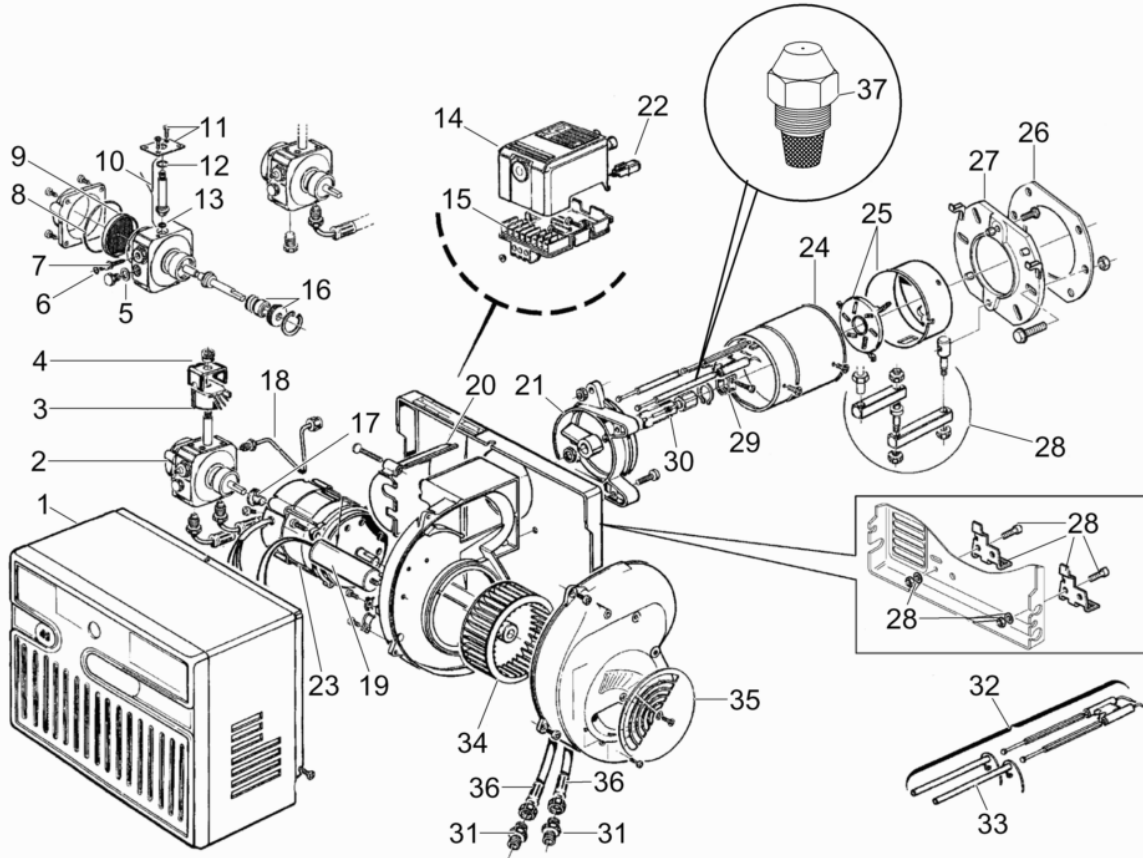

ghiex0168077100_01

Ref. Pos.	Part No. Artikel Nr.	Qty. St.	Description Beschreibung	Descripción Description	Measurement/Abm.	Norm
					Torque/Drehm.	Sealant Schmierstoff
1	0175144	1	Burner cover Brennerabdeckung	Tapa del quemador Couver-brûleur		
2	0175145	1	Fuel Pump Kraftstoffpumpe	Bomba de Combustible Pompe à Carburant		
3	0172665	1	Coil Spule	Bobina Bobine		
4	0172664	1	Bracket Konsole	Soporte Support		
5	0172656	1	Washer Scheibe	Arandela Rondelle		
6	0172657	1	O-Ring O-Ring	Anillo-O Joint torique		
7	0172676	1	Regulator Regulator	Regulador Régulateur		
8	0172658	1	O-Ring O-Ring	Anillo-O Joint torique		
9	0172659	1	Screen Sieb	Tamiz Tamis		
10	0172660	1	Valve Ventil	Válvula Soupape		
11	0172669	1	Plate Platte	Placa Plaque		
12	0172661	1	O-Ring O-Ring	Anillo-O Joint torique		
13	0172662	1	O-Ring O-Ring	Anillo-O Joint torique		
14	0175146	1	Control Box cpl. Kontrollkasten kpl.	Caja de Control compl. Boîtier de Commande compl.	530SE	
15	0169288	1	Primary control sub-base Sub-Konsole, Hauptbetätigung	Subbase, control primario Sous-base, commande principale		
16	0175147	1	Seal-shaft Wellendichtring	Sello del eje Bague d'étanchéité		
17	0169290	1	Drive key Keil	Chaveta Clavette		
18	0175148	1	Fuel line Kraftstoffleitung	Manguera de combustible Conduit de carburant		
19	0175149	1	Capacitor Kondensator	Condensador Condensateur		
20	0175150	1	Cover Deckel	Tapa Couvercle		
21	0175151	1	Collar Manschette	Collar Collet		
22	0169292	1	Photo cell Photozelle	Fotocelda Cellule photoélectrique		
23	0169291	1	Motor Motor	Motor Moteur	220V	
24	0175152	1	Blast tube Brennerrohr	Estalle tubo Estalle tubo		
25	0175153	1	Ring and diffuser disc Flammkopf+stauscheibe	Llame y disco de difusor Embout gueulard + af		

Burner cpl.
Brenner, kpl.
Quemador, acopl.
Brûleur compl.

HSH 650

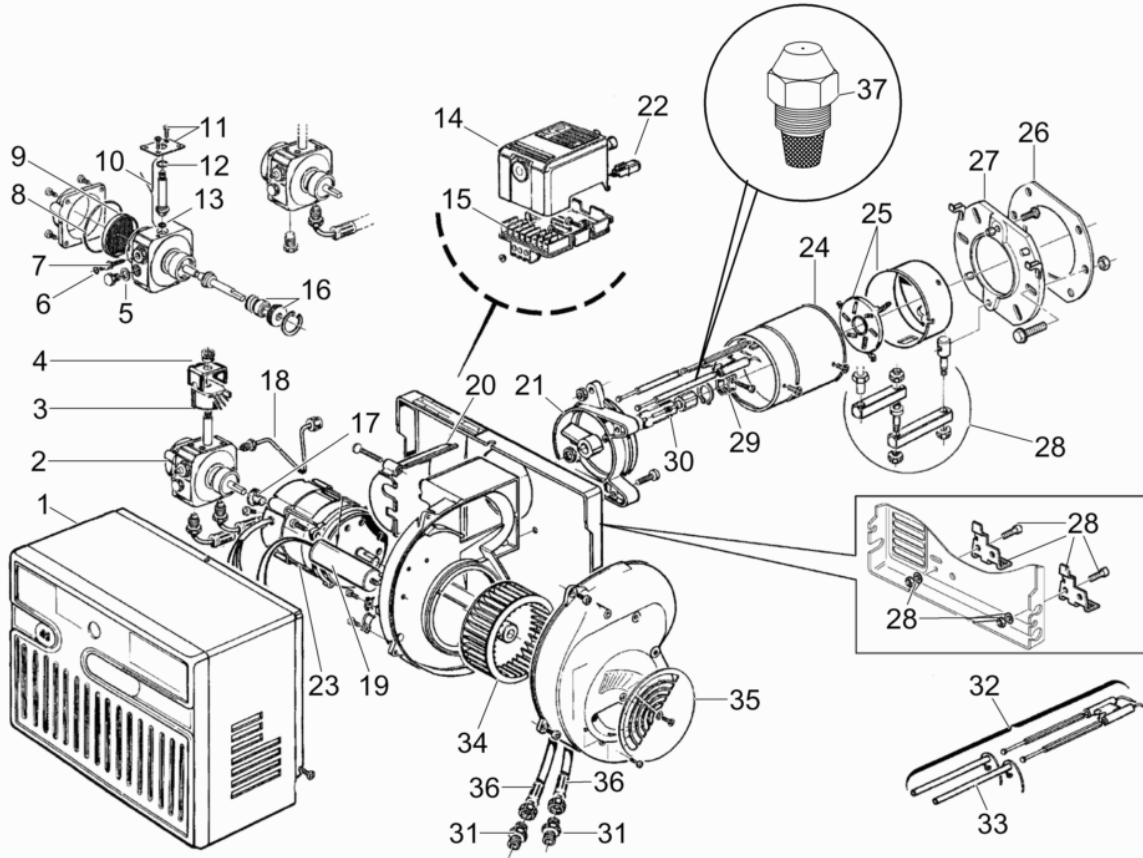

ghiex0168077100_01

Ref. Pos.	Part No. Artikel Nr.	Qty. St.	Description Beschreibung	Descripción Description	Measurement/Abm.	Norm
					Torque/Drehm.	Sealant Schmierstoff
26	0175154	1	Gasket Dichtung	Junta Joint		
27	0175155	1	Flange Flansch	Brida Collerette		
28	0175157	1	Hinge cpl. Scharnier	Bisagra Charnière		
29	0175159	1	Bracket Konsole	Soporte Support		
30	0175160	1	Nozzle retainer Düsenhalter	Retenedor de tobera de inyección Support de gicleur		
31	0175161	1	Connector Anschlußteil	Conector Connecteur		
32	0175162	1	Electrode cpl. Elektrode	Electrodo Électrode		
33	0175163	1	Insulator Isoliermaterial	Aislación Matière isolante		
34	0172650	1	Fan Gebläserad	Ventilador Ventilateur		
35	0172679	1	Cover Deckel	Tapa Couvercle		
36	0175164	1	Flexible tube Schlauch	Manguera Tuyau flexible		
37	0169209	1	Nozzle Düse	Tobera Ajutage		

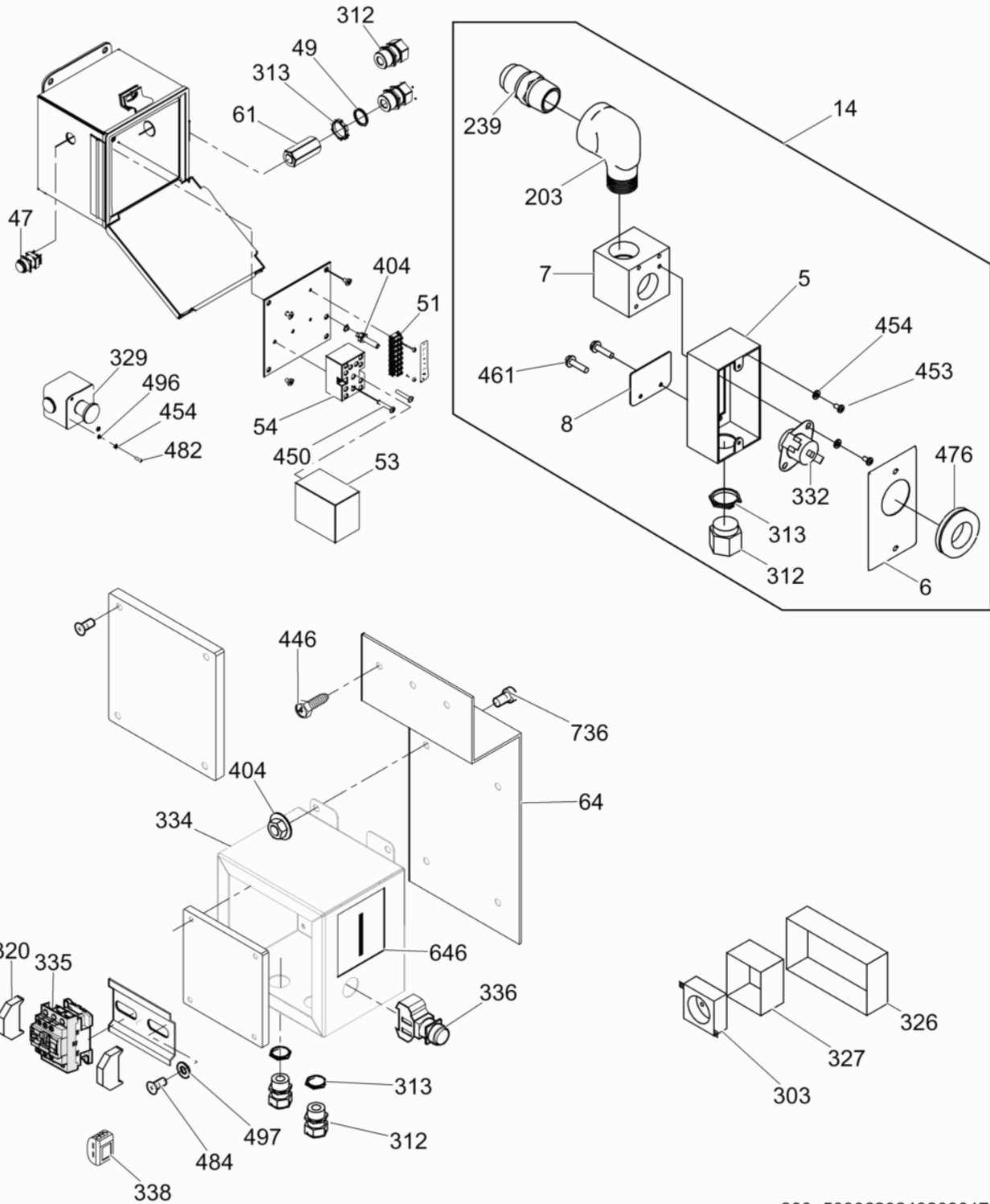

200_5000620243208017

Ref. Pos.	Part No. Artikel Nr.	Qty. St.	Description Beschreibung	Descripción Description	Measurem./Abm.	Norm
					Torque/Drehm.	Sealant Schmierstoff
5	0166931	1	Enclosure Gehäuse	Cubierta Enceinte		
6	0166930	1	Cover plate Deckplatte	Placa de cubierta Couvercle de protection	4 x 2-1/8in	
7	0166926	1	Snap disc block Schnapp-Scheibenblock	Bloque de discos de retención Bloc de disque d'arrêt		
8	0166927	1	Cover plate Deckplatte	Placa de cubierta Couvercle de protection		
14	0165639	1	Snap switch cpl. Sprengschalter kpl.	Interruptor de retención compl. Interrupteur extérieur compl.		
47	0166808	1	Switch Schalter	Interruptor Interrupteur		
49	0166810	1	Seal ring Dichtungsring	Anillo sellador Rondelle à étancher	1/2in NPT	
51	0166807	1	Terminal strip Klemmenleiste	Regleta de bornes Barrette de raccordement		
53	0166805	1	Module Modul	Módulo Module		
54	0166806	1	Relay base Relais	Relai Relais		
61	0176467	1	Filter Filter	Filtro Filtre		
64	0173144	1	Bracket Konsole	Soporte Support		
203	0168029	1	Elbow Krümmer	Codo Coude	3/4in NPT	
239	0168372	1	Adapter Adapter	Adaptador Raccord	3/4 x 5/8in	
303	0166790	2	Receptacle (socket) Steckdose	Tomacorriente Prise de courant		
312	0166458	1	Cord grip Zugentlastung	Alivio de esfuerzos Effort à la décharge	1/2in	
313	0166459	1	Lock nut Sicherungsmutter	Contratuerca Contre-écrou		
320	0170668	2	Terminal block end Anschlussblockende	Extremo Fin de bloc teminal		
326	0166788	1	Electrical box Schaltkasten	Caja eléctrica Coffret électrique		
327	0166789	2	Cover Deckel	Tapa Couvercle		
329	0172078	1	Emergency stop switch Not-Aus Schalter	Interruptor de parada de emergencia Interrupteur d'arrêt d'urgence		
332	0166613	1	Limit control Grenztaster	Interruptor limitador Interrupteur-limiteur		
334	0173160	1	Enclosure Gehäuse	Cubierta Enceinte		
335	0173163	1	Relay Relais	Relai Relais	25A	
336	0173164	1	Momentary switch Momentschalter	Interruptor momentáneo Interrupteur sans maintien		

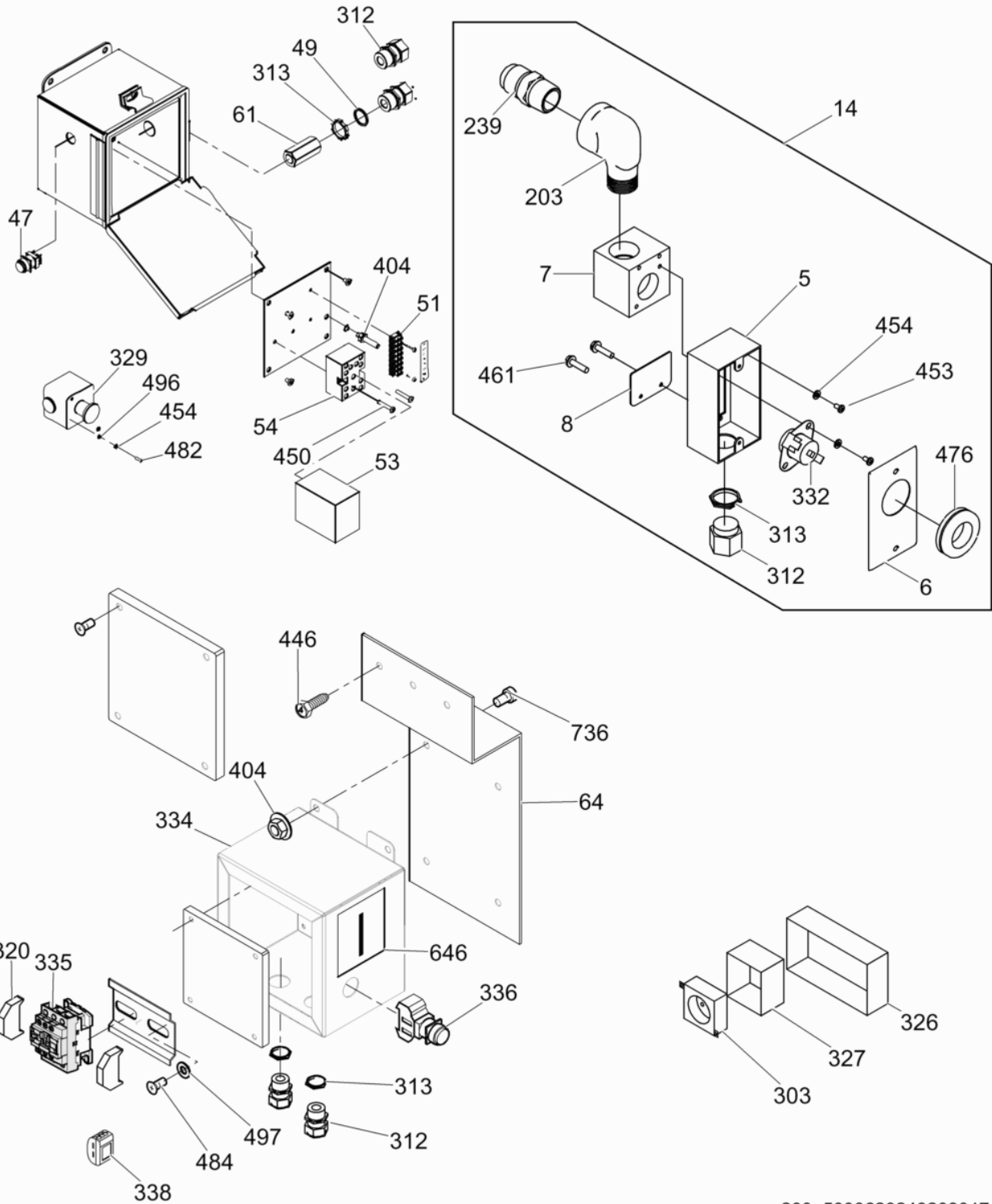

200_5000620243208017

Ref. Pos.	Part No. Artikel Nr.	Qty. St.	Description Beschreibung	Descripción Description	Measurement/Abm.	Norm
					Torque/Drehm.	Sealant Schmierstoff
338	0166833	6	Terminal Anschlußklemme	Terminal de conexión Borne d'attache	12-28 GA	
404	0167690	4	Nut Mutter	Tuerca Écrou	1/4in - 20	
446	0167793	3	Screw Schraube	Tornillo Vis	1/4-14 x 3/4in	
450	0167821	2	Screw Schraube	Tornillo Vis	No. 8-32 x 1	
453	0167835	4	Screw Schraube	Tornillo Vis	6-32 x 1/4in	
454	0167838	4	Washer Scheibe	Arandela Rondelle	No. 6	
461	0167883	2	Screw Schraube	Tornillo Vis	No. 10 x 3/4	
476	0168477	1	Grommet Tülle	Ojal Passe-fil	1-3/8 x 1in ID	
482	0167836	2	Screw Schraube	Tornillo Vis	6-32x 1/2	
484	0167897	2	Screw Schraube	Tornillo Vis	8-32 x 3/8	
496	0167850	1	Nut Mutter	Tuerca Écrou	6-32	
496	0167838	2	Washer Scheibe	Arandela Rondelle	No. 6	
497	0167921	2	Washer-lock Federring	Arandela elástica Rondelle de ressort	No. 8	
646	0173166	1	Label Aufkleber	Calcomania Autocollant		
736	0173162	4	Bolt Bolzen	Perno Boulon	1/4-20 x 1in	

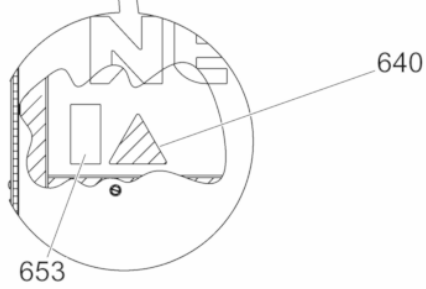
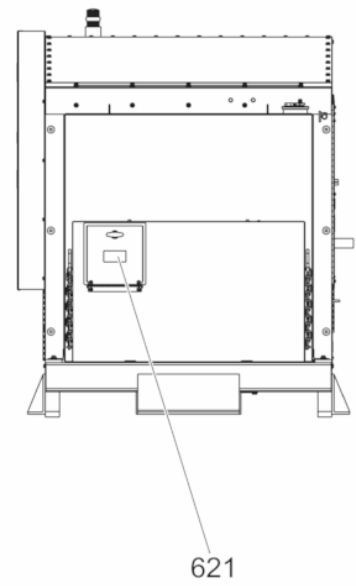
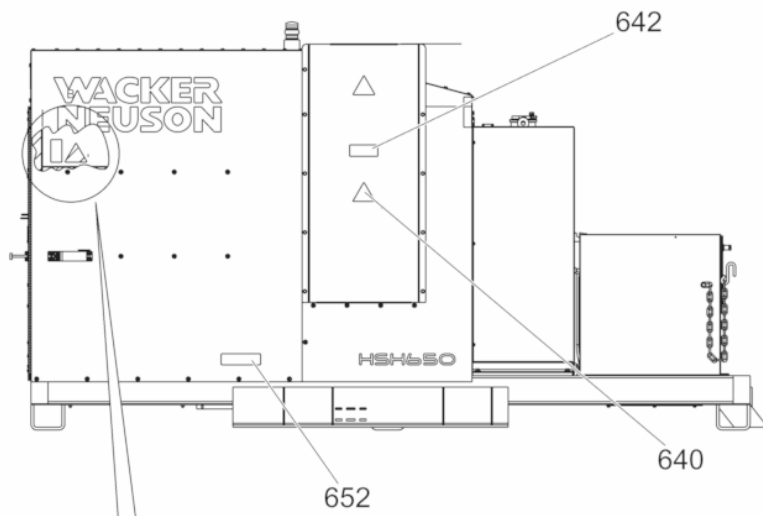
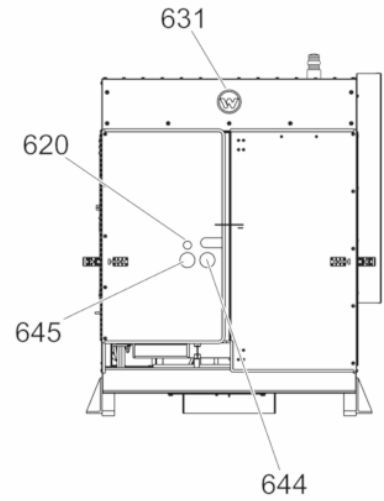
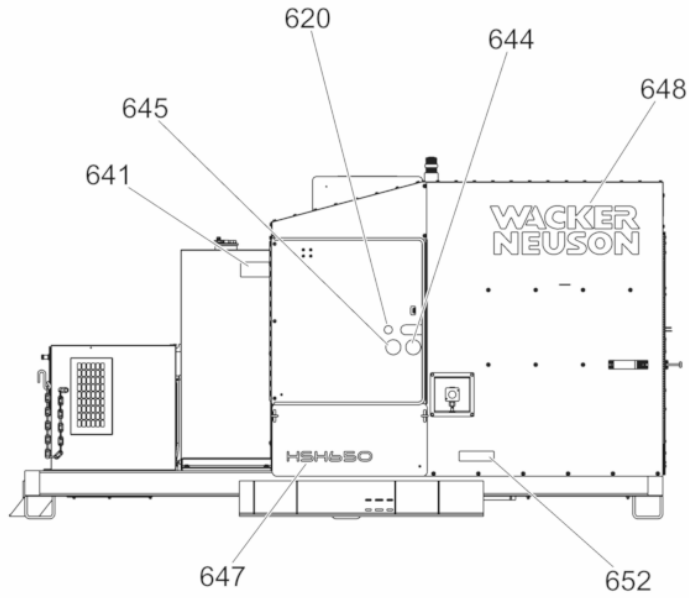

200_5000620991103028

Ref. Pos.	Part No. Artikel Nr.	Qty. St.	Description Beschreibung	Descripción Description	Measurem./Abm.	Norm
					Torque/Drehm.	Sealant Schmierstoff
620	0168895	2	Label-consult Operator's Manual Aufkleber	Calcomania Autocollant		
621	0181146	1	Label-warning Aufkleber-Warnung	Calcomania-Advertencia Autocollant-Avertissement		
631	0222087	1	Label-Wacker Neuson symbol Aufkleber-Wacker Neuson symbol	Calcomanía-Wacker Neuson símbolo Autocollant-Wacker Neuson symbole	120 OD	
640	0168893	3	Label-hot surface Aufkleber-heisse Oberfläche	Calcomania-superficie caliente Autocollant-surface brûlante		
641	0181145	1	Label-caution Aufkleber-Vorsicht	Calcomanía-precaución Autocollant-précaution		
642	0181144	1	Label-danger Aufkleber, Gefahr	Calcomanía, peligro Autocollant-danger		
644	0168891	2	Label-safety gloves Aufkleber, Sicherheitshandschuhe	Calcomanía-guantes de seguridad Autocollant-gants de sécurité		
645	0168892	2	Label-eye protection Aufkleber	Calcomania Autocollant		
647	0189343	2	Label Aufkleber	Calcomania Autocollant		
648	0180221	2	Label-logo Aufkleber, Logo	Calcomanía-logotipo Autocollant - logo		
652	5000193926	1	Label Aufkleber	Calcomania Autocollant		
653	0181147	2	Label-hot fluids Aufkleber	Calcomania Autocollant		

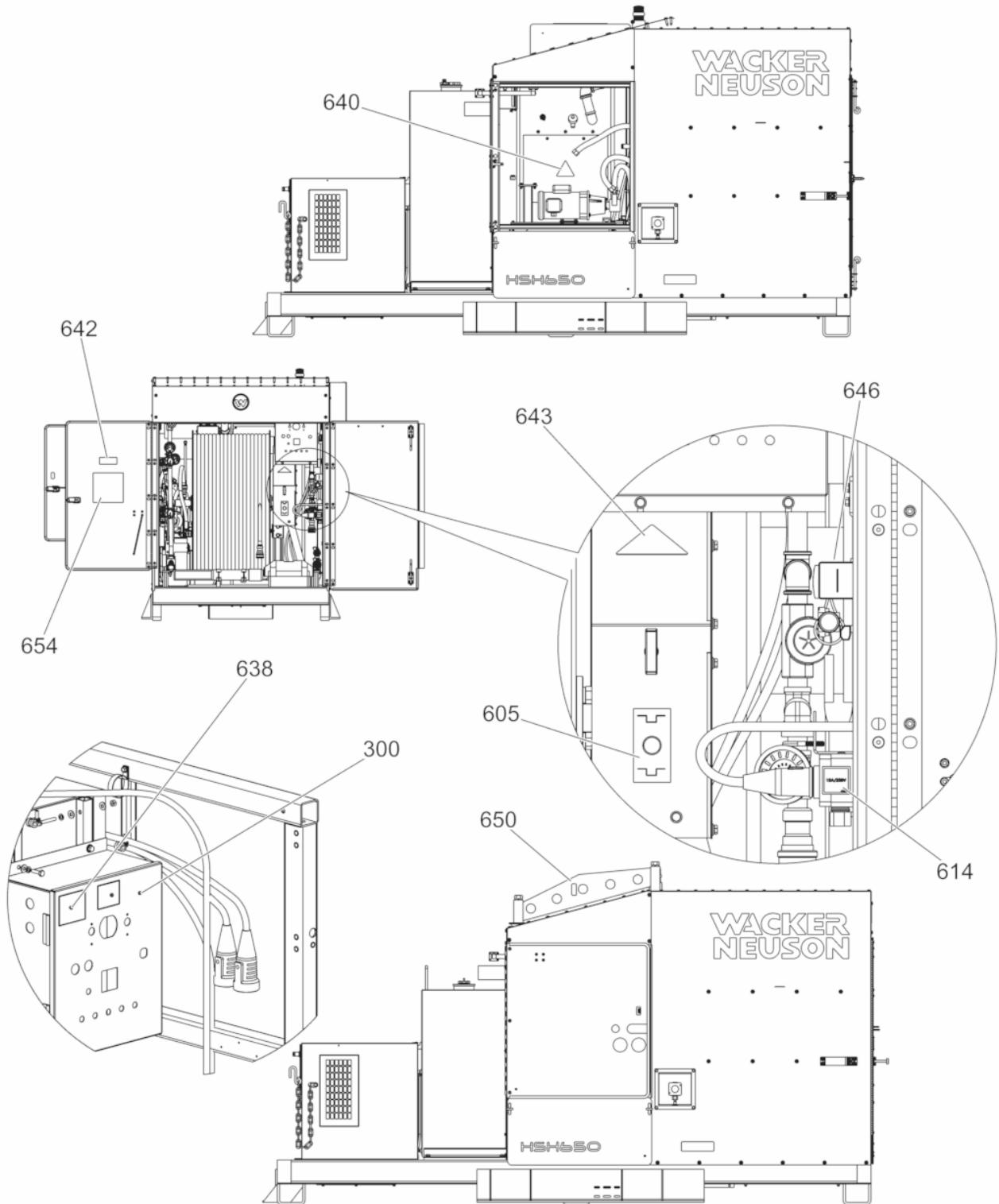

200_5000620991103029

Ref. Pos.	Part No. Artikel Nr.	Qty. St.	Description Beschreibung	Descripción Description	Measurement./Abm.	Norm
					Torque/Drehm.	Sealant Schmierstoff
300	0166216	1	Control panel cpl. Schalttafel-Anlage kpl.	Conjunto tablero de control compl. Tableau de commande compl.		
605	0172223	1	Label-hose reel brake Aufkleber	Calcomania Autocollant		
614	0172225	1	Label Aufkleber	Calcomania Autocollant		
638	0189341	1	Label-rating plate Aufkleber	Calcomania Autocollant		
640	0168893	1	Label-hot surface Aufkleber-heisse Oberfläche	Calcomania-superficie caliente Autocollant-surface brûlante		
642	0181144	1	Label-danger Aufkleber, Gefahr	Calcomanía, peligro Autocollant-danger		
643	0168890	1	Label-hand entangled Aufkleber	Calcomania Autocollant		
646	0173166	1	Label Aufkleber	Calcomania Autocollant		
650	0181148	2	Label-lift point Aufkleber	Calcomania Autocollant		
654	0181218	1	Label-operation Aufkleber-Betrieb	Calcomania-Operación Autocollant-Opération		

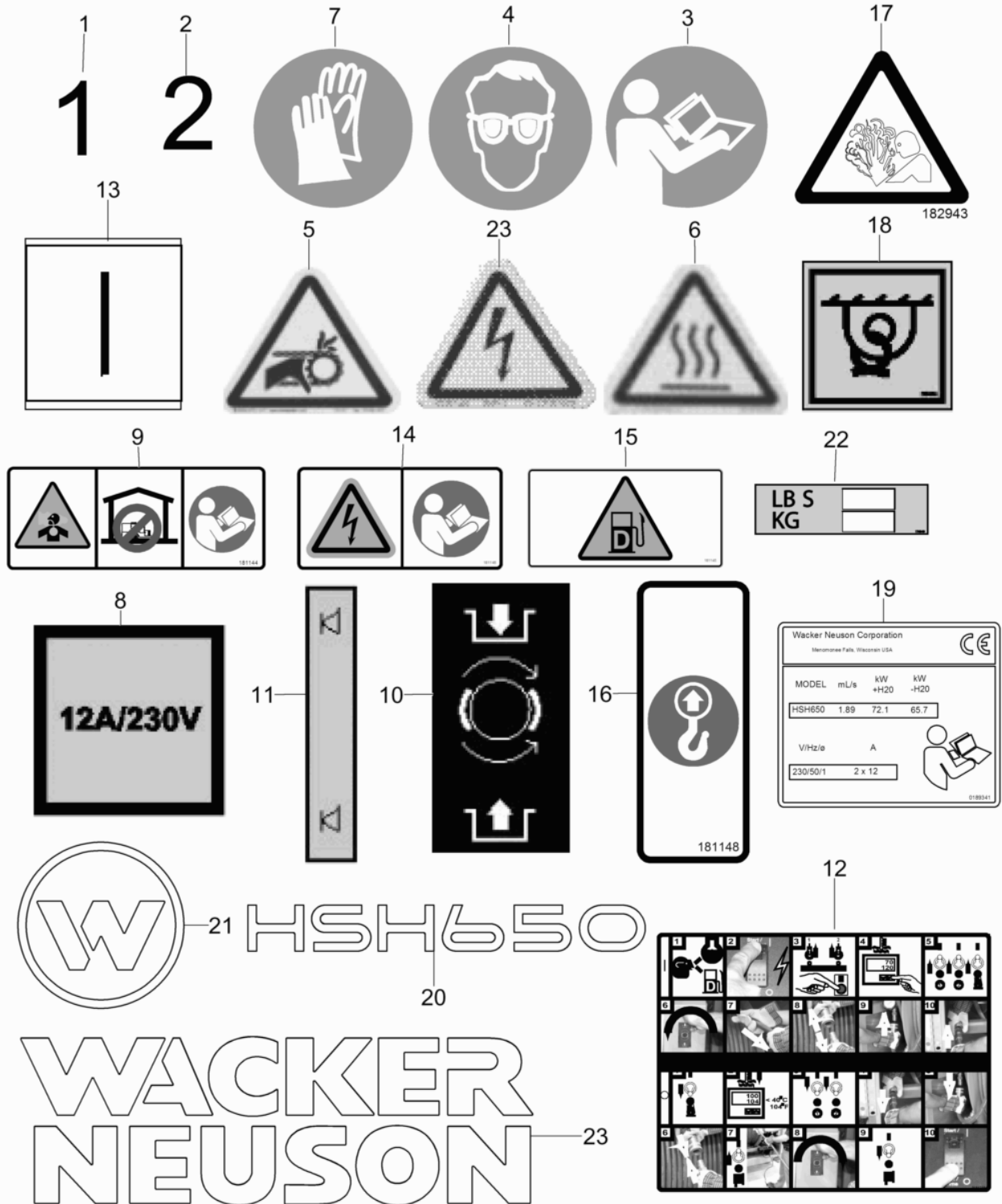

200_5000620991102_01

Ref. Pos.	Part No. Artikel Nr.	Qty. St.	Description Beschreibung	Descripción Description	Measurem./Abm.	Norm
					Torque/Drehm.	Sealant Schmierstoff
1	0168663	1	Label-pump temperature gauge Aufkleber	Calcomania Autocollant		
2	0168664	1	Label-pump temperature gauge Aufkleber	Calcomania Autocollant		
3	0168895	1	Label-consult Operator's Manual Aufkleber	Calcomania Autocollant		
4	0168892	1	Label-eye protection Aufkleber	Calcomania Autocollant		
5	0168890	1	Label-hand entangled Aufkleber	Calcomania Autocollant		
6	0168893	1	Label-hot surface Aufkleber-heisse Oberfläche	Calcomania-superficie caliente Autocollant-surface brûlante		
7	0168891	1	Label-safety gloves Aufkleber, Sicherheitshandschuhe	Calcomanía-guantes de seguridad Autocollant-gants de sécurité		
8	0172225	1	Label Aufkleber	Calcomania Autocollant		
9	0181144	1	Label-danger Aufkleber, Gefahr	Calcomanía, peligro Autocollant-danger		
10	0172223	1	Label-hose reel brake Aufkleber	Calcomania Autocollant		
11	0172365	1	Label-heat transfer fluid level Aufkleber	Calcomania Autocollant		
12	0181218	1	Label-operation Aufkleber-Betrieb	Calcomania-Operación Autocollant-Opération		
13	0173166	1	Label Aufkleber	Calcomania Autocollant		
14	0181146	1	Label-warning Aufkleber-Warnung	Calcomania-Advertencia Autocollant-Avertissement		
15	0181145	1	Label-caution Aufkleber-Vorsicht	Calcomanía-precaución Autocollant-précaution		
16	0181148	1	Label-lift point Aufkleber	Calcomania Autocollant		
17	0182943	1	Label Aufkleber	Calcomania Autocollant		
18	0173202	1	Label-tie down Aufkleber- Verzerrung	Calcomanía-amarre Autocollant-arrimage		
19	0189341	1	Label-rating plate Aufkleber	Calcomania Autocollant		
20	0189343	1	Label Aufkleber	Calcomania Autocollant		
21	0222087	1	Label-Wacker Neuson symbol Aufkleber-Wacker Neuson symbol	Calcomanía-Wacker Neuson símbolo Autocollant-Wacker Neuson symbole	120 OD	
22	5000193926	1	Label Aufkleber	Calcomania Autocollant		
23	0168894	1	Label-electric shock Aufkleber	Calcomania Autocollant		

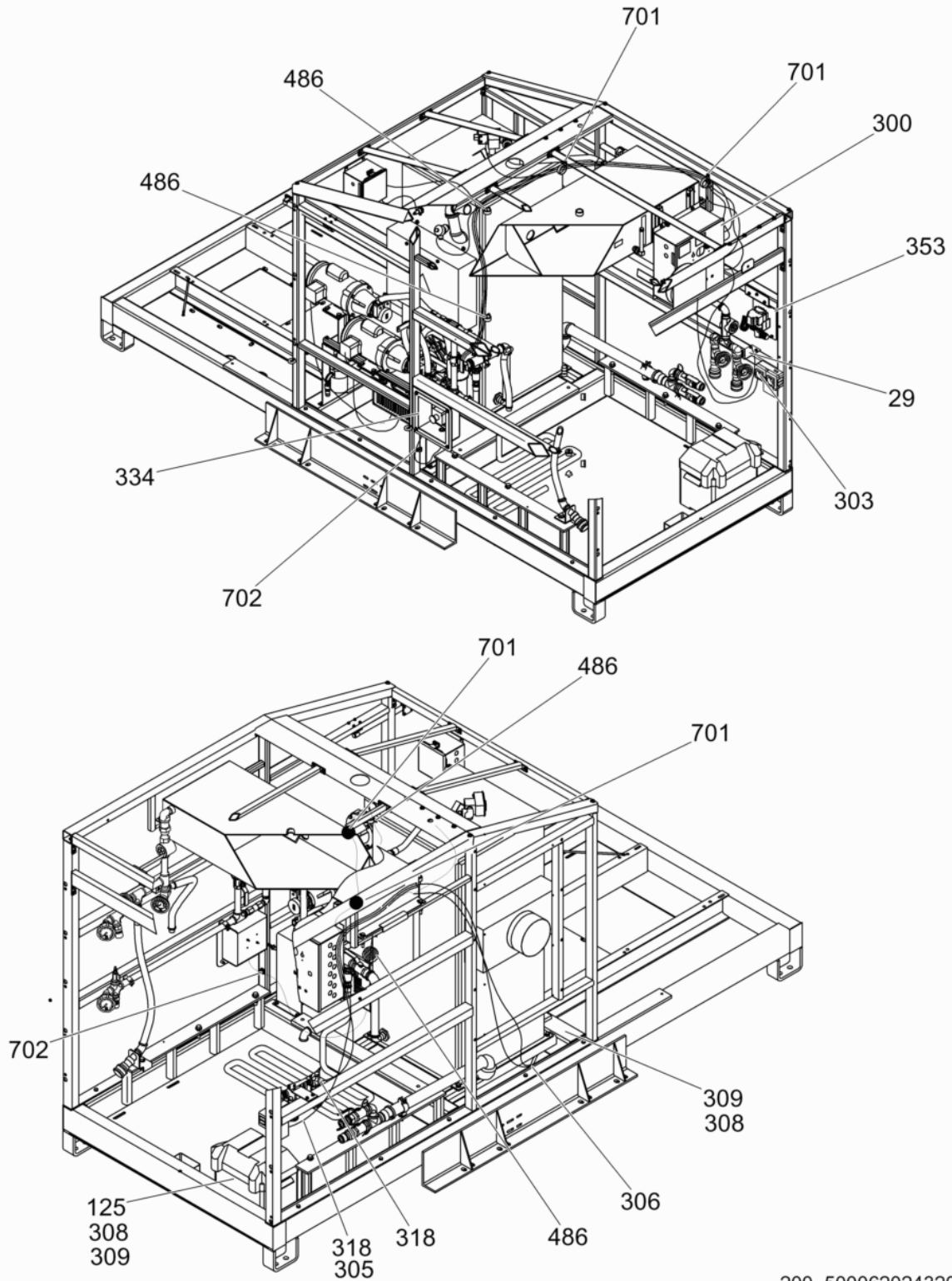

200_5000620243208026

Ref. Pos.	Part No. Artikel Nr.	Qty. St.	Description Beschreibung	Descripción Description	Measurem./Abm.	Norm
					Torque/Drehm.	Sealant Schmierstoff
29	0166905	1	Bracket Konsole	Soporte Support		
125	0168169	1	Battery box Batteriekasten	Caja de batería Boîte de batterie		
300	0166216	1	Control panel cpl. Schalttafel-Anlage kpl.	Conjunto tablero de control compl. Tableau de commande compl.		
303	0166790	2	Receptacle (socket) Steckdose	Tomacorriente Prise de courant		
305	0166792	1	Plug Stopfen	Tapón Bouchon		
306	0166798	2	Plug Stopfen	Tapón Bouchon		
308	0166647	1	Positive battery cable, red Plusbatteriekabel	Cable positivo de batería Câble positif de batterie		
309	0166648	1	Negative battery cable Minusbatteriekabel	Cable negativo de batería Câble négatif de batterie		
318	0166792	2	Plug Stopfen	Tapón Bouchon		
334	0173160	1	Enclosure Gehäuse	Cubierta Enceinte		
353	0173671	1	Lifting bracket Hebebügel	Ménsula alzadora Support de relèvement		
486	0167699	1	Bolt Bolzen	Perno Boulon	1/2-13 x 1-1/2in	
486	0168129	3	Clamp Schelle	Abrazadera Agrafe		
701	0168904	2	Loop strap Schlaufe	Correa de lazo Sangle		
702	0168356	2	Clamp Schelle	Abrazadera Agrafe		

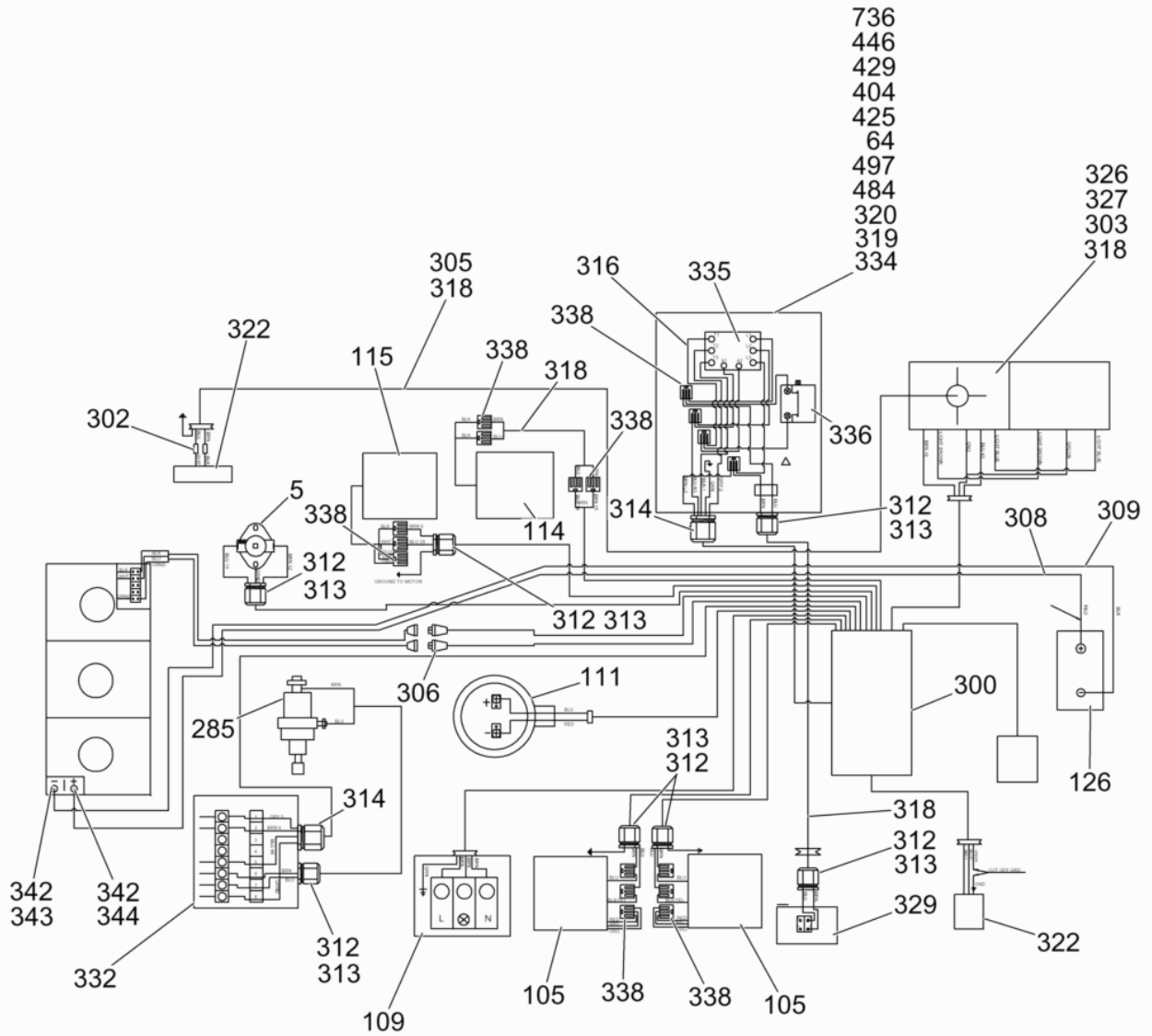

200_5000620243208027

Ref. Pos.	Part No. Artikel Nr.	Qty. St.	Description Beschreibung	Descripción Description	Measurement./Abm.	Norm
					Torque/Drehm.	Sealant Schmierstoff
5	0166931	1	Enclosure Gehäuse	Cubierta Enceinte		
64	0173144	1	Bracket Konsole	Soporte Support		
105	0168277	2	Pump Pumpe	Bomba Pompe	265gph	
109	0168077	1	Burner Brenner	Quemador Brûleur	50Hz	
111	0166712	1	Thermocouple Thermoelement	Termopar Thermocouple		
114	0168104	1	Clutch Kupplung	Embrague Embrayage		
115	0168755	1	Gear Zahnrad	Engranaje Engrenage		
126	0165552	1	Battery Batterie	Batería Batterie	12V	
285	0166811	1	Electrode Elektrode	Electrodo Électrode		
300	0166216	1	Control panel cpl. Schalttafel-Anlage kpl.	Conjunto tablero de control compl. Tableau de commande compl.		
302	0166423	2	Splice Spleiße	Empalme Épissure	14 GA	
303	0166790	2	Receptacle (socket) Steckdose	Tomacorriente Prise de courant		
305	0166792	1	Plug Stopfen	Tapón Bouchon		
306	0166798	1	Plug Stopfen	Tapón Bouchon		
308	0166647	1	Positive battery cable, red Plusbatteriekabel	Cable positivo de batería Câble positif de batterie		
309	0166648	1	Negative battery cable Minusbatteriekabel	Cable negativo de batería Câble négatif de batterie		
312	0166458	7	Cord grip Zugentlastung	Alivio de esfuerzos Effort à la décharge	1/2in	
313	0166459	6	Lock nut Sicherungsmutter	Contratuercas Contre-écrou		
314	0166473	2	Cord grip Zugentlastung	Alivio de esfuerzos Effort à la décharge	1/2in	
316	0173175	8	Wire Kabel	Alambre Fil		
318	0170230	3	Cord Kabel	Cable Cordon	18/3	
319	0170665	1	Rail Schiene	Riel Rail	35mm	
320	0170668	2	Terminal block end Anschlussblockende	Extremo Fin de bloc terminal		
322	0166793	2	Light fixture Licht	Artefacto Projecteur	50Hz	
326	0166788	1	Electrical box Schaltkasten	Caja eléctrica Coffret électrique		

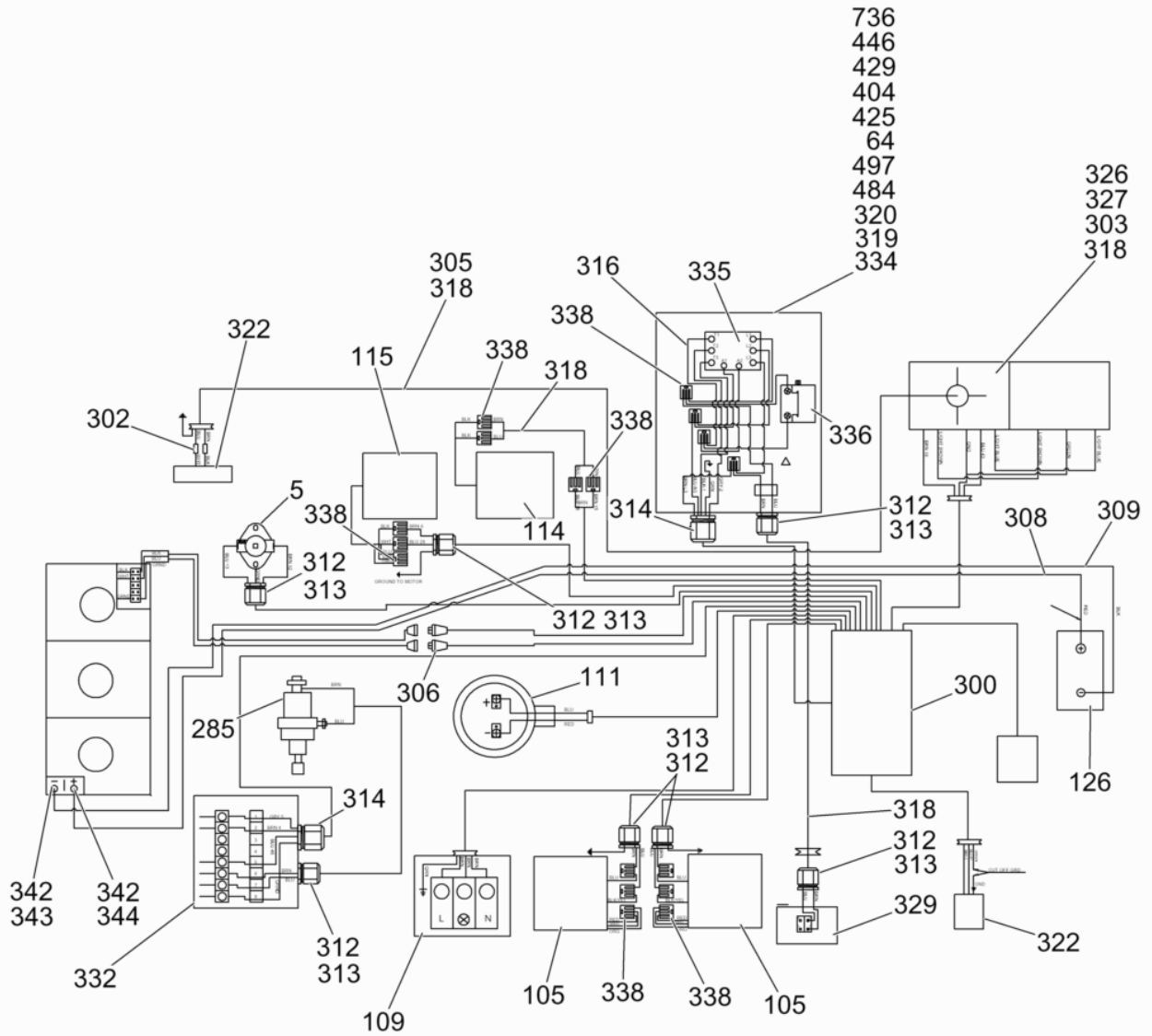

200_5000620243208027

Ref. Pos.	Part No. Artikel Nr.	Qty. St.	Description Beschreibung	Descripción Description	Measurement/Abm.	Norm
					Torque/Drehm.	Sealant Schmierstoff
327	0166789	2	Cover Deckel	Tapa Couvercle		
329	0172078	1	Emergency stop switch Not-Aus Schalter	Interruptor de parada de emergencia Interrupteur d'arrêt d'urgence		
332	0166613	1	Limit control Grenztaster	Interruptor limitador Interrupteur-limiteur		
334	0166687	1	Boot, insulated wire, red Manschette, isolierter Draht	Zapata, alambre aislado Gaine, fil isolé		
335	0173163	1	Relay Relais	Relai Relais	25A	
336	0173164	1	Momentary switch Momentschalter	Interruptor momentáneo Interrupteur sans maintien		
338	0166833	17	Terminal Anschlußklemme	Terminal de conexión Borne d'attache	12-28 GA	
342	0166650	2	Terminal Anschlußklemme	Terminal de conexión Borne d'attache		
343	0166686	1	Boot, insulated wire, black Manschette, isolierter Draht	Zapata, alambre aislado Gaine, fil isolé		
344	0166687	1	Boot, insulated wire, red Manschette, isolierter Draht	Zapata, alambre aislado Gaine, fil isolé		
404	0167690	4	Nut Mutter	Tuerca Écrou	1/4in - 20	
425	0167729	4	Flat washer Scheibe	Arandela elástica Rondelle de ressort	1/4in	
429	0167722	4	Screw w/washer Schraube mit Scheibe	Tornillo con arandela Vis avec rondelle	10 x 3/4	
446	0167793	3	Screw Schraube	Tornillo Vis	1/4-14 x 3/4in	
484	0167897	2	Screw Schraube	Tornillo Vis	8-32 x 3/8	
497	0167921	2	Washer-lock Federring	Arandela elástica Rondelle de ressort	No. 8	
736	0173162	4	Bolt Bolzen	Perno Boulon	1/4-20 x 1in	

E-Stop Box cpl.
Not-Aus Kasten kpl.

HSH 650

Caja de parada de emergencia compl.
Boîte d'arrêt d'urgence compl.

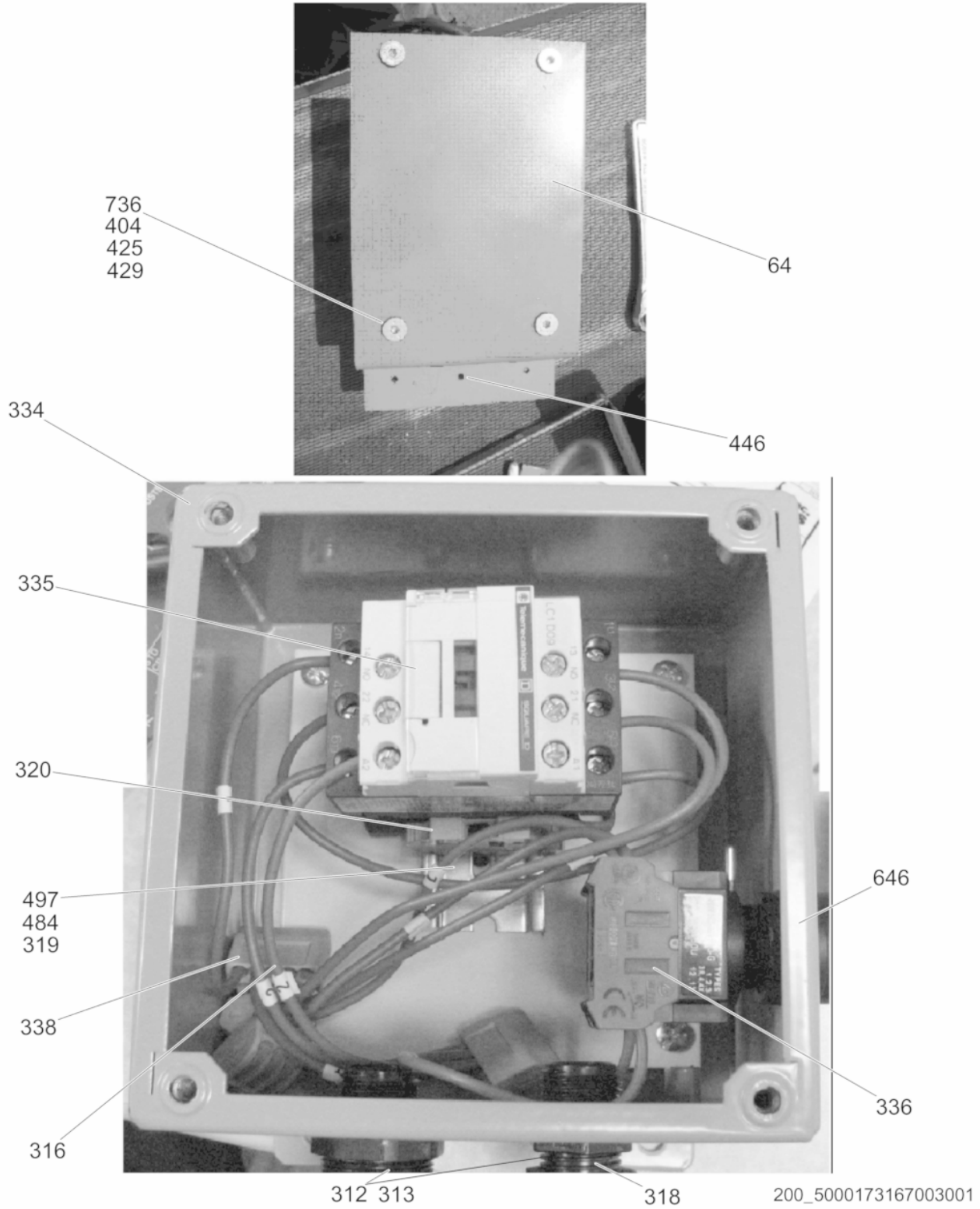

Ref. Pos.	Part No. Artikel Nr.	Qty. St.	Description Beschreibung	Descripción Description	Measurem./Abm.	Norm
					Torque/Drehm.	Sealant Schmierstoff
64	0173144	1	Bracket Konsole	Soporte Support		
312	0166458	3	Cord grip Zugentlastung	Alivio de esfuerzos Effort à la décharge	1/2in	
313	0166459	3	Lock nut Sicherungsmutter	Contratuerca Contre-écrou		
316	0173175	1	Wire Kabel	Alambre Fil		
318	0170230	1	Cord Kabel	Cable Cordon	18/3	
319	0170665	1	Rail Schiene	Riel Rail	35mm	
320	0170668	1	Terminal block end Anschlussblockende	Extremo Fin de bloc teminal		
334	0173160	1	Enclosure Gehäuse	Cubierta Enceinte		
335	0173163	1	Relay Relais	Relai Relais	25A	
336	0173164	1	Momentary switch Momentschalter	Interruptor momentáneo Interrupteur sans maintien		
338	0166833	6	Terminal Anschlußklemme	Terminal de conexión Borne d'attache	12-28 GA	
404	0167690	4	Nut Mutter	Tuerca Écrou	1/4in - 20	
425	0167729	4	Flat washer Scheibe	Arandela elástica Rondelle de ressort	1/4in	
429	0167733	4	Lock washer Federring	Federring Rondelle de ressort	1/4in	
446	0167793	3	Screw Schraube	Tornillo Vis	1/4-14 x 3/4in	
484	0167897	1	Screw Schraube	Tornillo Vis	8-32 x 3/8	
497	0167921	2	Washer-lock Federring	Arandela elástica Rondelle de ressort	No. 8	
646	0173166	1	Label Aufkleber	Calcomania Autocollant		
736	0173162	4	Bolt Bolzen	Perno Boulon	1/4-20 x 1in	



**WACKER
NEUSON**

**Generator Service Parts
Generatorenersatzteile
Repuestos para Generadores
Pièces Détachées des Groupes Électrogènes**

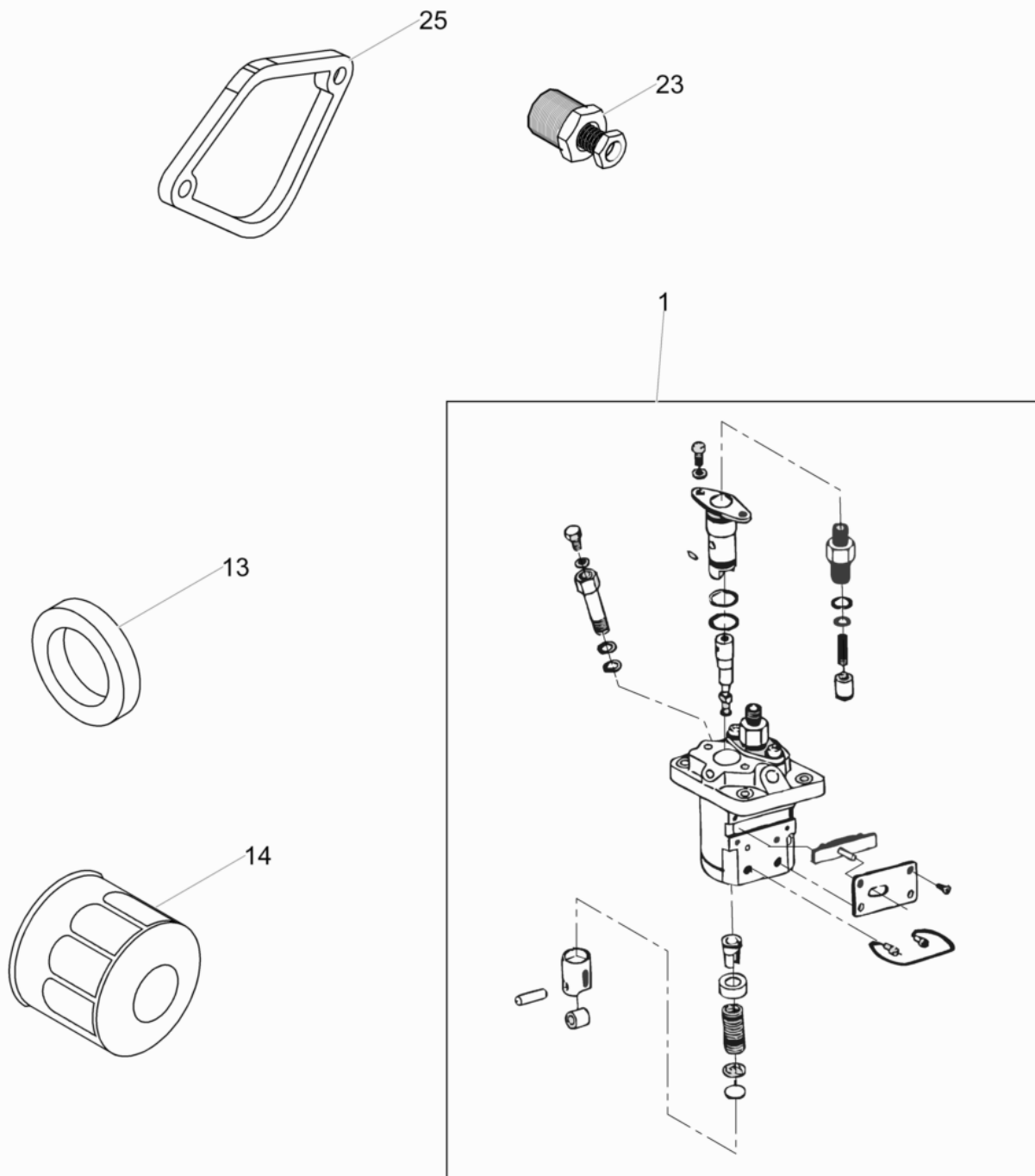

ghiex0168754100_01

Ref. Pos.	Part No. Artikel Nr.	Qty. St.	Description Beschreibung	Descripción Description	Measurem./Abm.	Norm
					Torque/Drehm.	Sealant Schmierstoff
1	0176545	1	Injection Pump Kit Einspritzpumpesatz	Juego de Bomba Inyectora Jeu de Pompe d'Injection		
13	0176544	1	Oil seal Öldichtung	Empaque de aceite Joint d'huile		
14	0169158	1	Oil filter Ölfilter	Filtro de aceite Filtre d'huile		
23	0176482	1	Pressure switch Druckschalter	Interruptor de Presión Interrupteur à Pression		
25	0176517	1	Gasket Dichtung	Junta Joint		

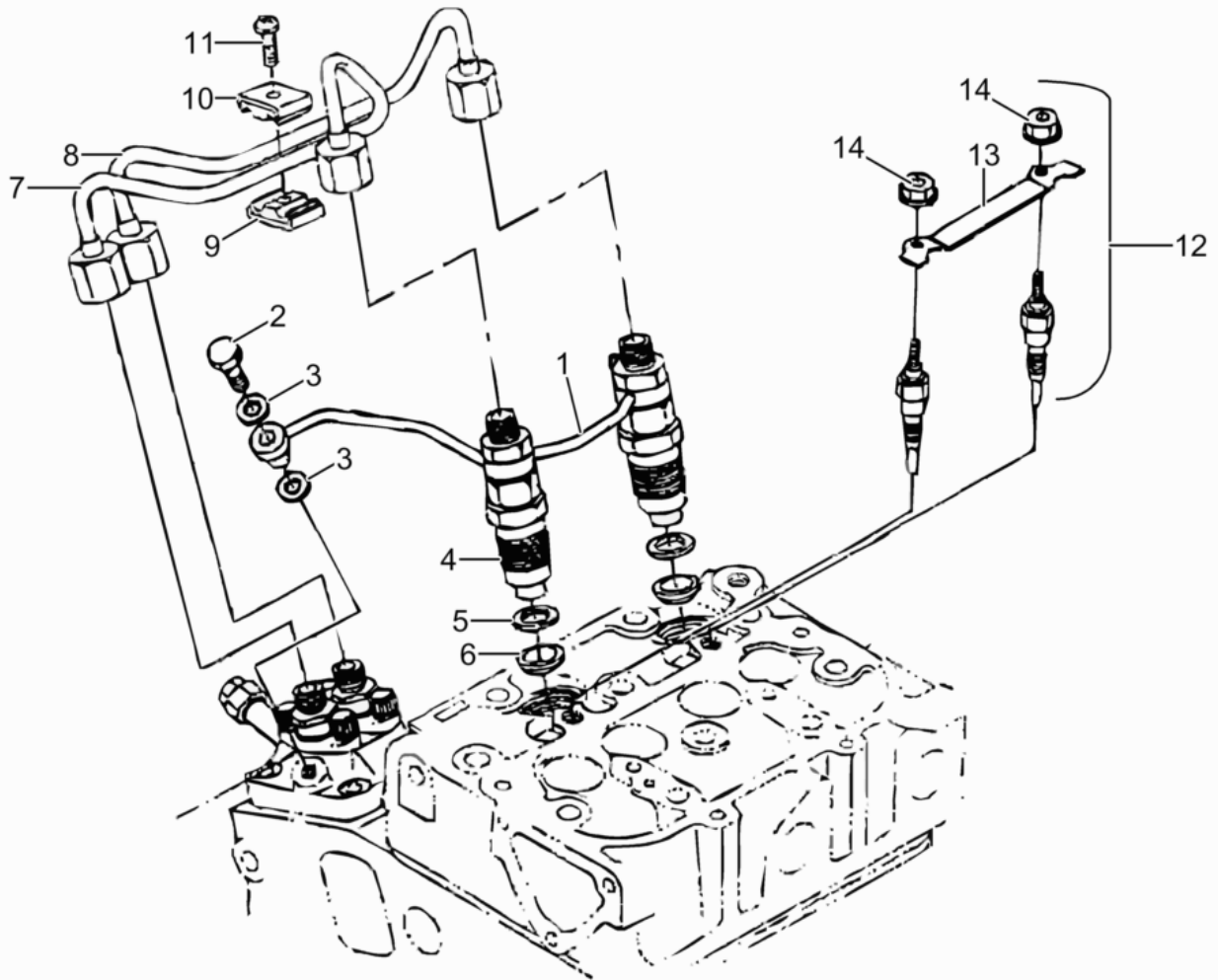

ghiex0168754100_02

Ref. Pos.	Part No. Artikel Nr.	Qty. St.	Description Beschreibung	Descripción Description	Measurement./Abm.	Norm
					Torque/Drehm.	Sealant Schmierstoff
1	0176518	1	Overflow hose Überlaufschlauch	Manguera de rebose Tuyau de trop-plein		
2	0176519	1	Bleed screw Ablassschraube	Tornillo sangrador Vis de vidange		
3	0176520	2	Gasket Dichtung	Junta Joint		
4	0176521	2	Nozzle body (holder) Düse	Tobera Ajutage		
5	0176522	2	Gasket Dichtung	Junta Joint		
6	0176523	2	Seal Dichtung	Empaque Joint		
7	0176524	1	Injection pipe Einspritzrohr	Tubo inyector Tube d'injection		
8	0176525	1	Injection pipe Einspritzrohr	Tubo inyector Tube d'injection		
9	0176526	1	Clamp Schelle	Abrazadera Agrafe		
10	0176527	1	Clamp Schelle	Abrazadera Agrafe		
11	0176528	1	Pan head screw Flachkopfschraube	Tornillo de cabeza de cono achatado Vis ber		
12	0176529	2	Glow plug Glühkerze	Tapón luminoso Bougie de préchauffage		
13	0176530	2	Wire-glow plug Glühkerzenkabel	Alambre para tapón encendedor Fil pour bougie de préchauffage		
14	0176531	2	Flange nut Flanschmutter	Tuerca de reborde Ecrou de bride		

Cylinder Head Cover
Zylinderkopfhaube
Tapa del Cilindro
Couvercle Supérieur

HSH 650

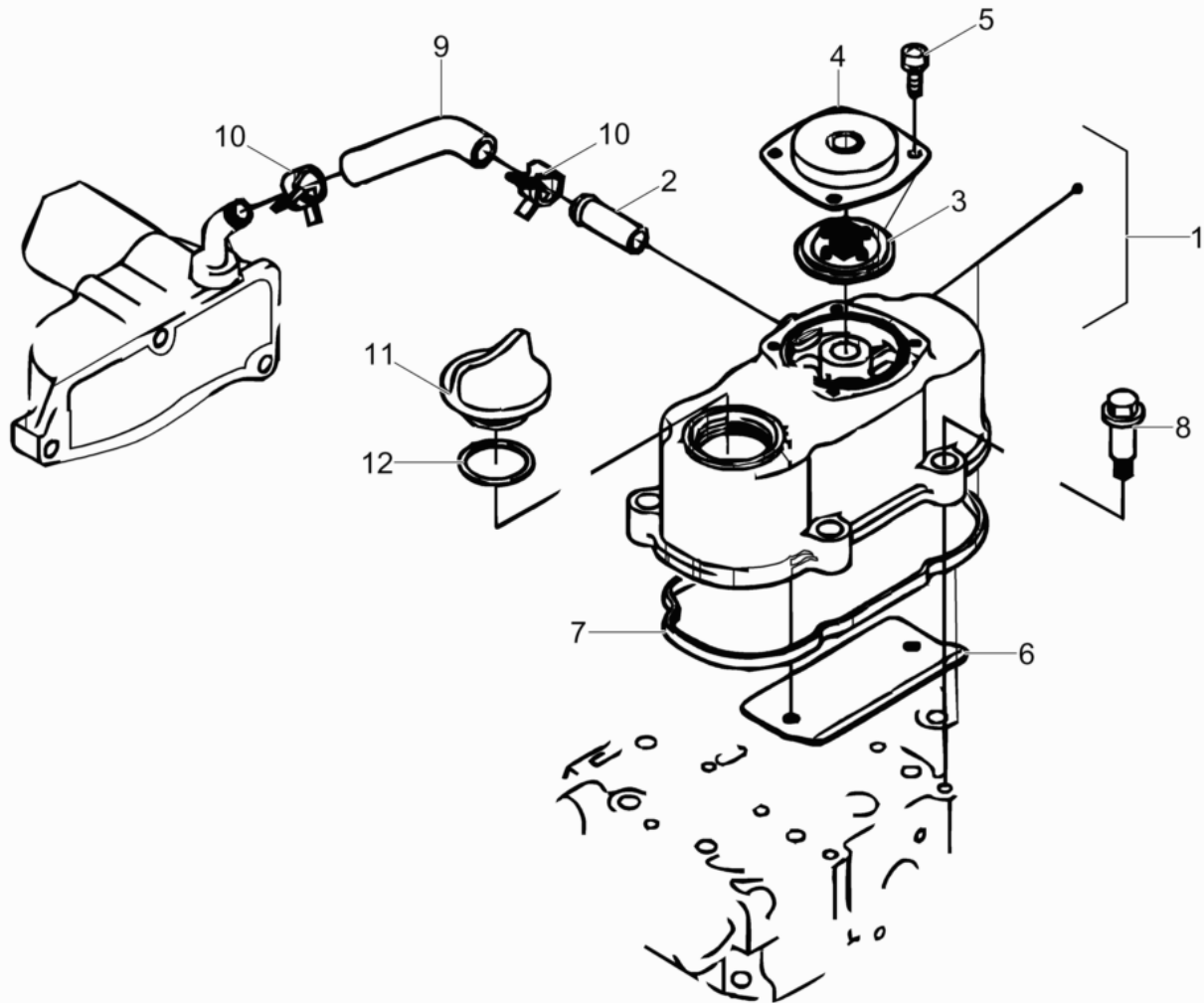

ghiex0168754100_03

Ref. Pos.	Part No. Artikel Nr.	Qty. St.	Description Beschreibung	Descripción Description	Measurement/Abm.	Norm
					Torque/Drehm.	Sealant Schmierstoff
1	0176532	1	Cylinder Head Cover Zylinderkopfhaube	Tapa del Cilindro Couvercle Supérieur		
2	0176574	1	Return pipe Rückleitungsrohr	Tubo de retorno Tuyau de retour		
3	0176534	1	Breather valve Entlüftungsventil	Válvula de ventilación Soupape reniflard		
4	0176535	1	Cover Deckel	Tapa Couvercle		
5	0176536	4	Screw w/washer Schraube mit Scheibe	Tornillo con arandela Vis avec rondelle		
6	0176537	1	Cover plate Deckplatte	Placa de cubierta Couvercle de protection		
7	0176538	1	Gasket Dichtung	Junta Joint		
8	0176539	4	Bolt Bolzen	Perno Boulon		
9	0176540	1	Tube-breather Entlüftungsrohr	Tubo respiradero Tube reniflard		
10	0176541	2	Hose clamp Schlauchschele	Abrazaderas de manguera Agrafe de tuyau		
11	0176542	1	Cap Kappe	Tapa Capuchon		
12	0176543	1	O-Ring O-Ring	Anillo-O Joint torique		

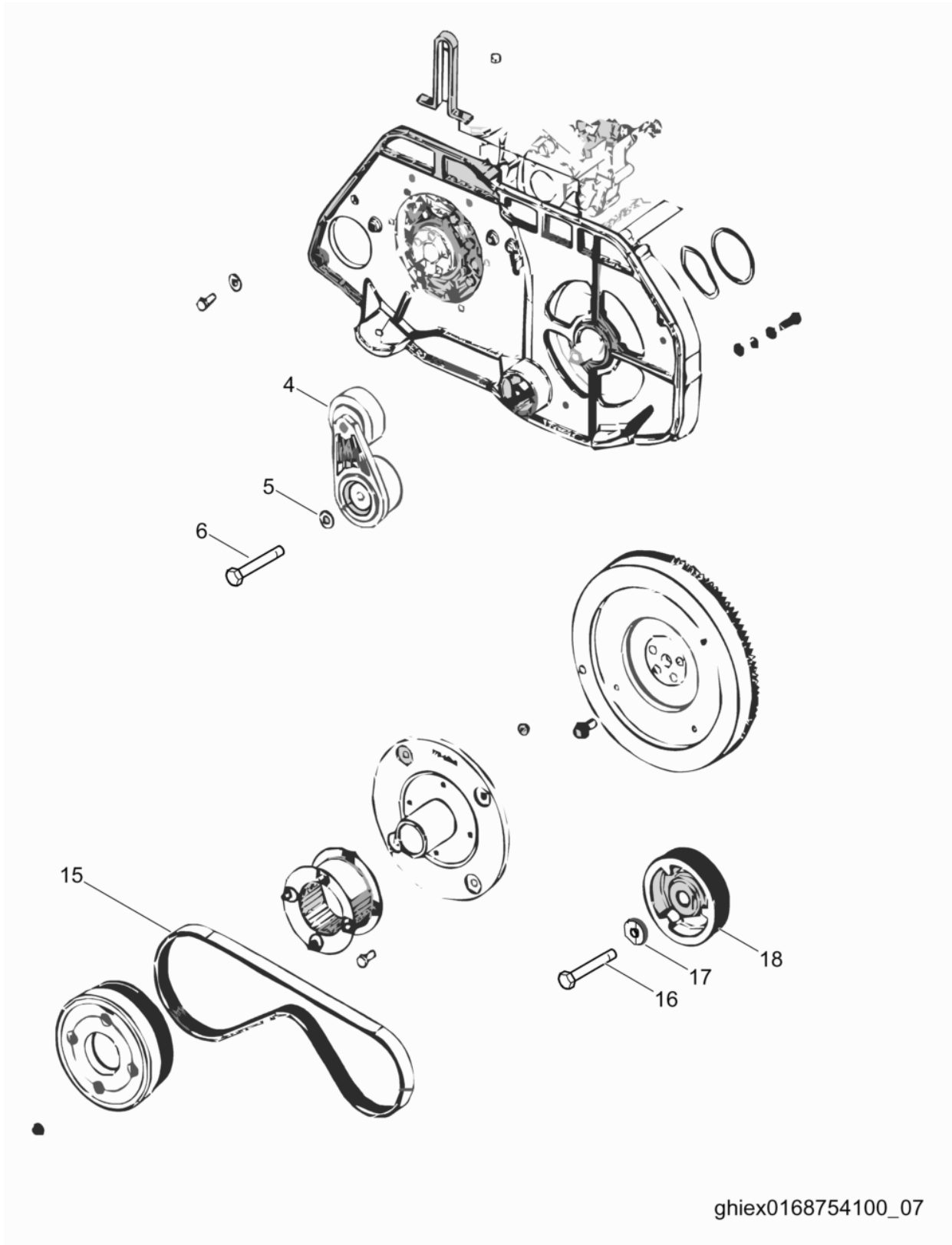

ghiex0168754100_07

Ref. Pos.	Part No. Artikel Nr.	Qty. St.	Description Beschreibung	Descripción Description	Measurement./Abm.	Norm
					Torque/Drehm.	Sealant Schmierstoff
4	0176546	1	Belt tensioner Riemenspannrolle	Polea tensora de correa Tendeur de courroie		
5	0176547	1	Flat washer Scheibe	Arandela elástica Rondelle de ressort	M10	
6	0176548	1	Screw Schraube	Tornillo Vis	3/8 x 16 x 2	
15	0176549	1	Belt Zahnriemen	Correa Courroie		
16	0176550	1	Screw Schraube	Tornillo Vis	M10 x 1	
17	0176551	1	Flat washer Scheibe	Arandela elástica Rondelle de ressort		
18	0176552	1	Pulley Scheibe	Polea Poulie		

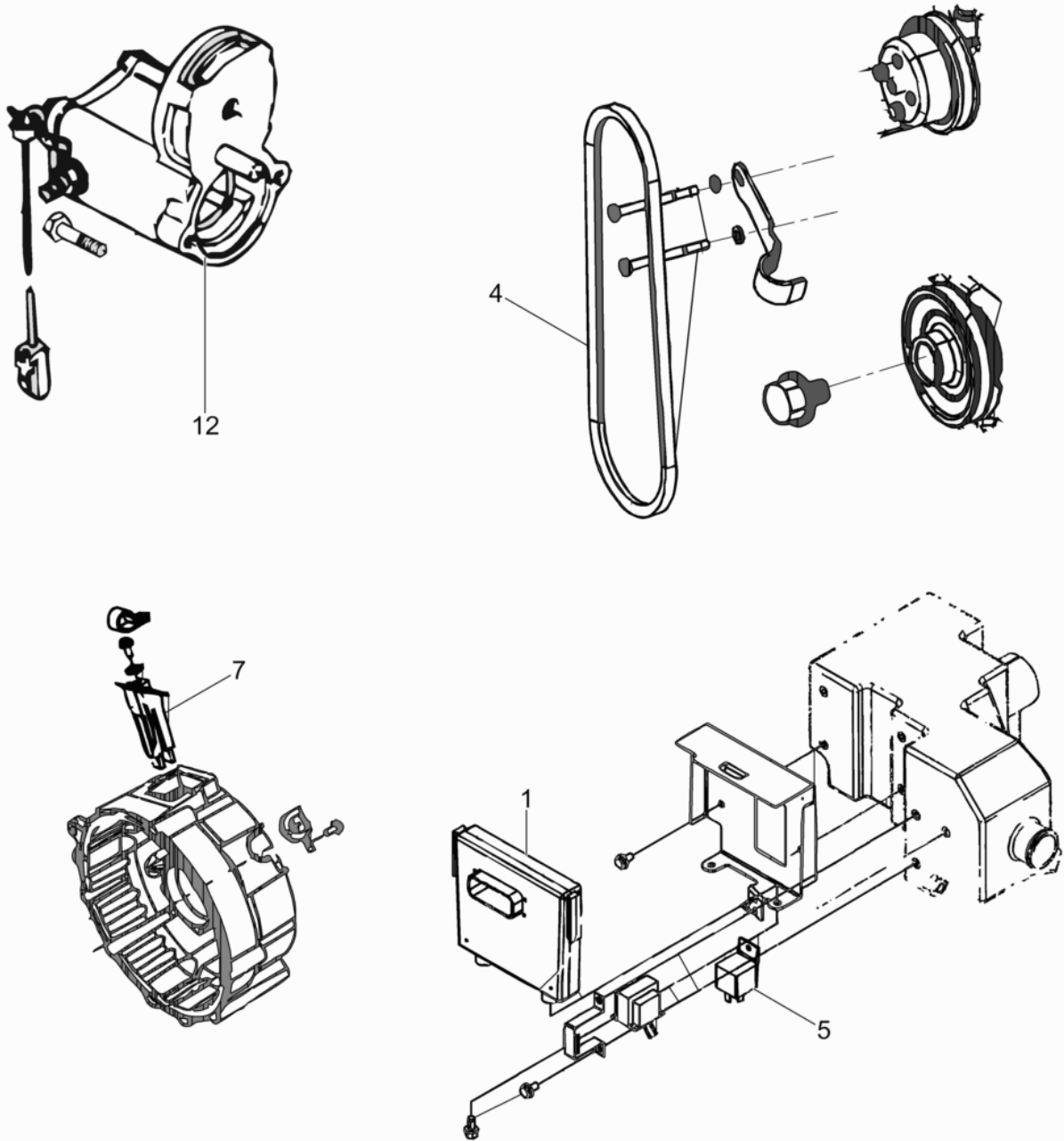

ghiex0168754100_08

Ref. Pos.	Part No. Artikel Nr.	Qty. St.	Description Beschreibung	Descripción Description	Measurement./Abm.	Norm
					Torque/Drehm.	Sealant Schmierstoff
1	0169176	1	Printed circuit board cpl., control Leiterplatte, kpl., Betätigung	Acopl. de tarjeta de circuitoscontrol Carte de circuit imprimé complcommande		
4	0174081	1	Belt Zahnriemen	Correa Courroie		
5	0169171	1	Relay Relais	Relai Relais		
7	0176633	1	Brush Kohlenbürste	Escobilla Balai de charbon		
12	0169168	1	Switch cpl. Schalter	Interruptor Interrupteur		

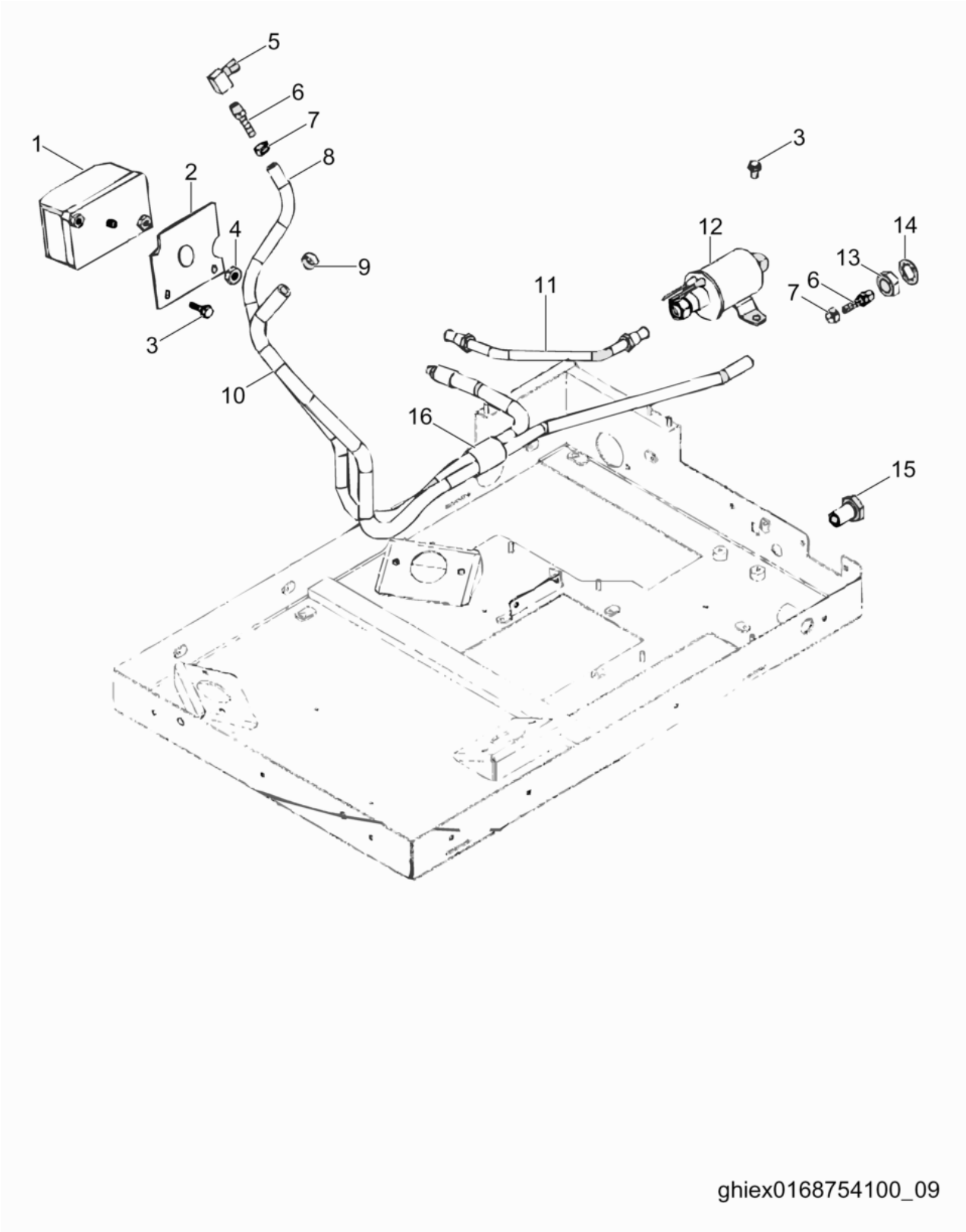

ghiex0168754100_09

Ref. Pos.	Part No. Artikel Nr.	Qty. St.	Description Beschreibung	Descripción Description	Measurem./Abm.	Norm
					Torque/Drehm.	Sealant Schmierstoff
1	0169157	1	Filter-fuel Kraftstofffilter	Filtro de combustible Filtre à carburant		
2	0176553	1	Filter bracket Filterhalterung	Ménsula del filtro Support de filtre		
3	0176632	4	Screw w/lockwasher Schraube mit Federring	Tornillo con arandela elástica Vis avec rondelle de ressort		
4	0176555	1	Lock nut Sicherungsmutter	Contratuerca Contre-écrou		
5	0176556	1	Elbow adapter Rohrkrümmter	Adaptador ele Raccord coudé		
6	0176557	2	Hose barb Schlauchwiderhaken	Púa de manguera Barbelure de flexible		
7	0176558	2	Hose clamp Schlauchschelle	Abrazaderas de manguera Agrafe de tuyau		
8	0176559	1	Fuel Hose Kraftstoffleitung	Manguera de combustible Tuyau de carburant		
9	0176560	1	Hose clamp Schlauchschelle	Abrazaderas de manguera Agrafe de tuyau		
10	0176561	1	Fuel Hose Kraftstoffleitung	Manguera de combustible Tuyau de carburant		
11	0176562	1	Fuel Hose Kraftstoffleitung	Manguera de combustible Tuyau de carburant		
12	0176563	1	Fuel Pump Kraftstoffpumpe	Bomba de Combustible Pompe à Carburant		
13	0176564	1	Hexagon nut Sechskantmutter	Tuerca hexagonal Écrou hexagonal		
14	0176565	1	Lock washer Federring	Federring Rondelle de ressort		
15	0176566	1	Adapter Adapter	Adaptador Raccord		
16	0176567	1	Clamp Schelle	Abrazadera Agrafe		

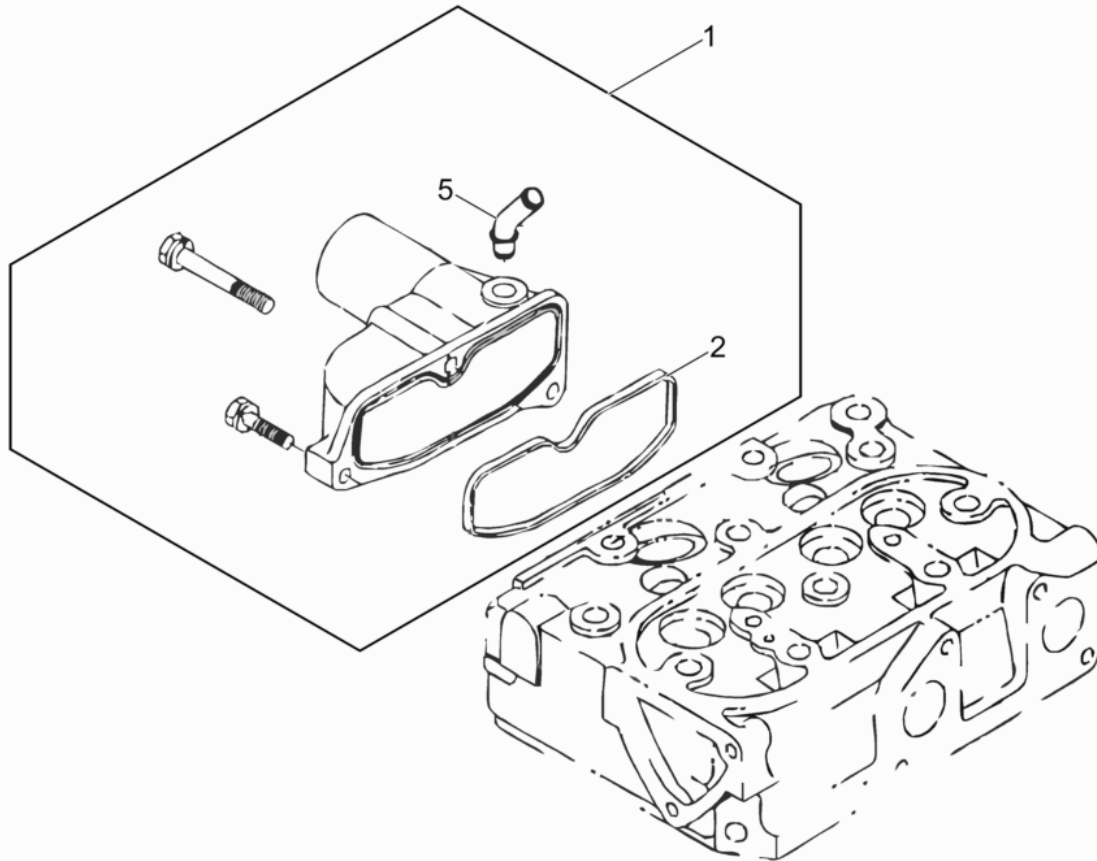

ghiex0168754100_10

Ref. Pos.	Part No. Artikel Nr.	Qty. St.	Description Beschreibung	Descripción Description	Measurem./Abm.	Norm
					Torque/Drehm.	Sealant Schmierstoff
1	0176568	1	Inlet valve Einlaßventil	Válvula de admisión Soupape d'admission		
2	0176569	1	Gasket Dichtung	Junta Joint		
5	0176570	1	Breather tube Entlüftungsrohr	Tubo respiradero Tube reniflard		

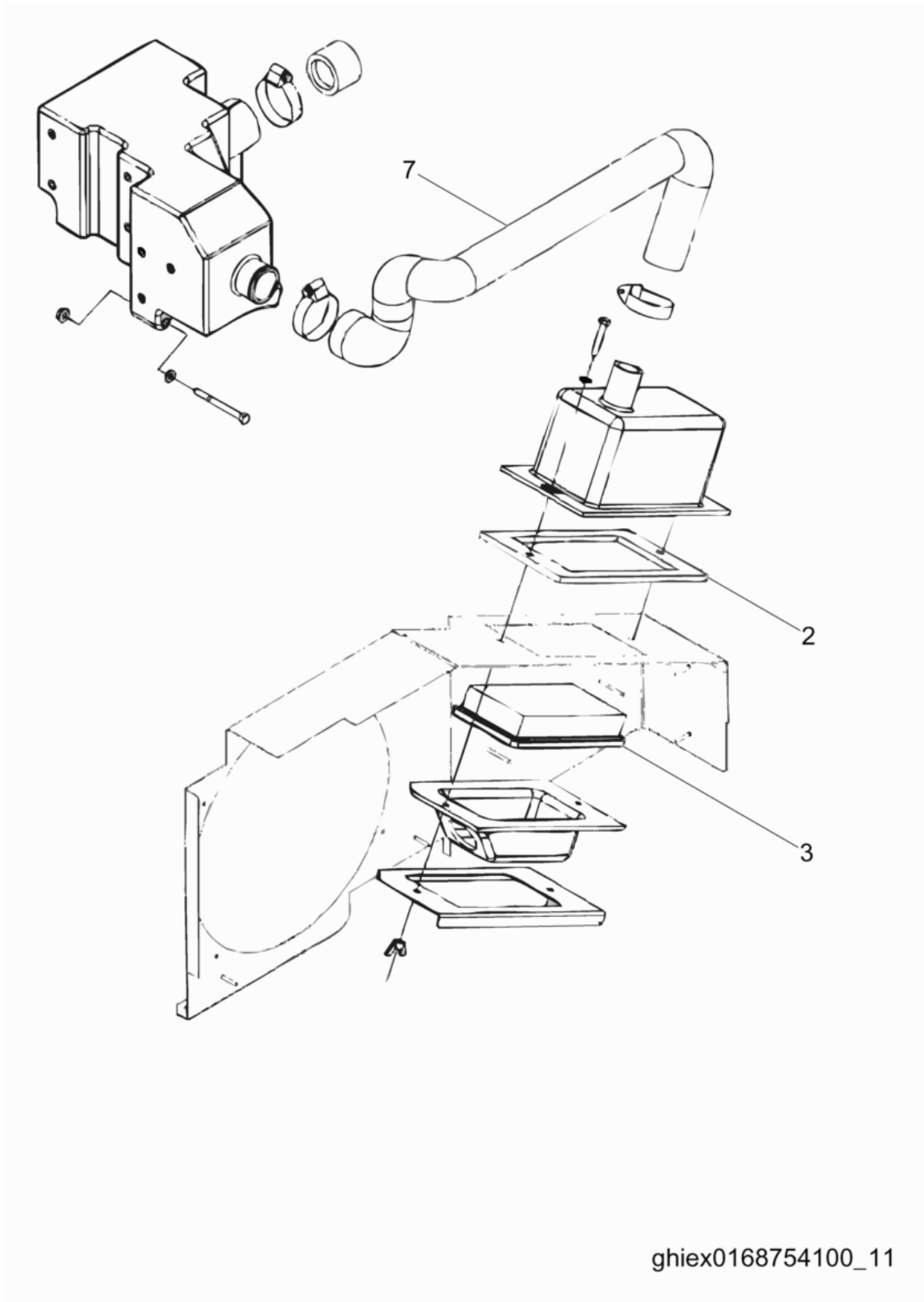

Ref. Pos.	Part No. Artikel Nr.	Qty. St.	Description Beschreibung	Descripción Description	Measurem./Abm.	Norm
					Torque/Drehm.	Sealant Schmierstoff
2	0176571	1	Gasket Dichtung	Junta Joint		
3	0169156	1	Air filter Luftfilter	Filtro del aire Filtre à air		
7	0176572	1	Air hose Druckluftschlauch	Manguera de aire Tuyau à air		

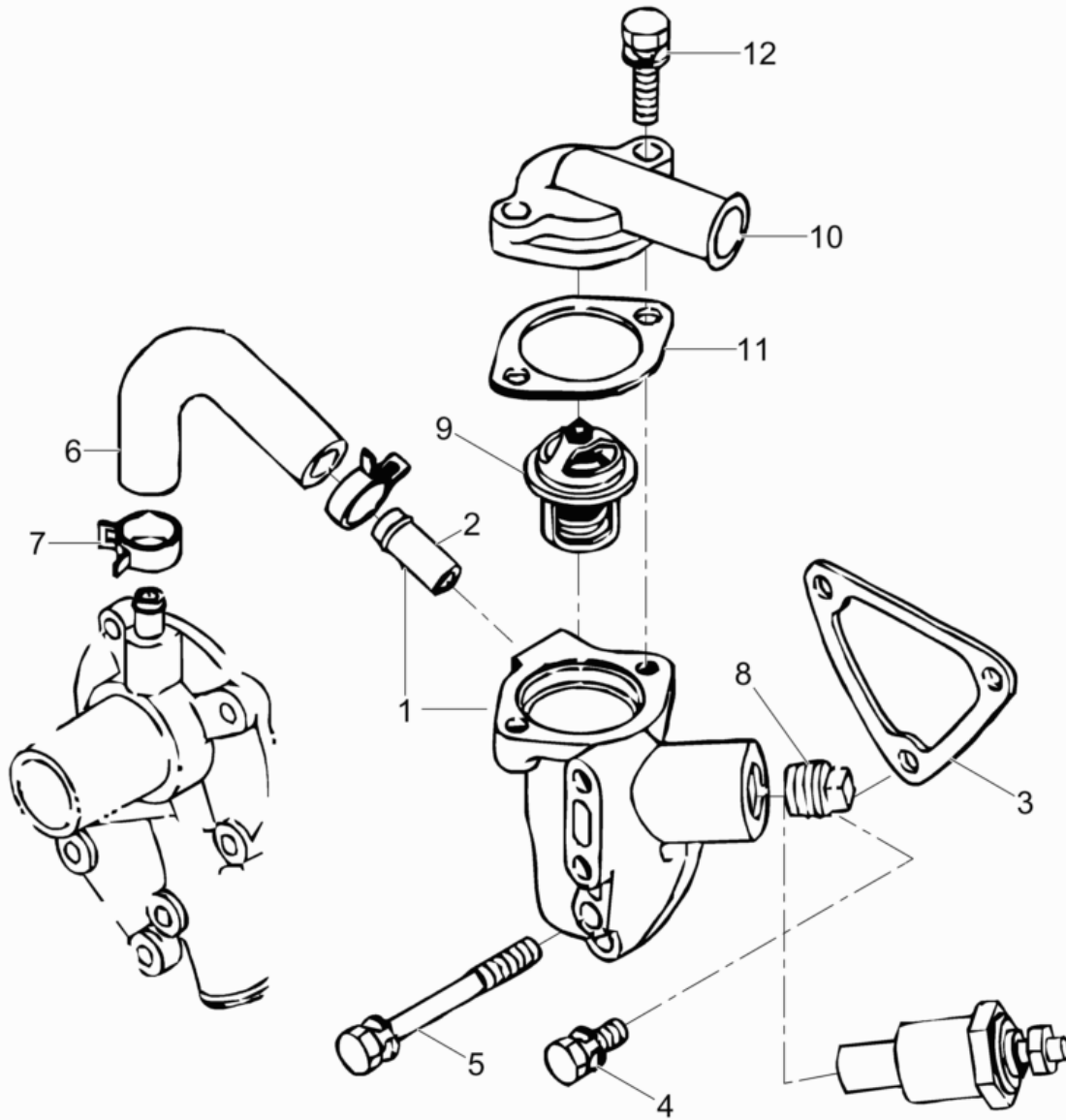

ghiex0168754100_12

Ref. Pos.	Part No. Artikel Nr.	Qty. St.	Description Beschreibung	Descripción Description	Measurem./Abm.	Norm
					Torque/Drehm.	Sealant Schmierstoff
1	0176573	1	Flange Flansch	Brida Collerette		
2	0176574	1	Return pipe Rückleitungsrohr	Tubo de retorno Tuyau de retour		
3	0176575	1	Gasket Dichtung	Junta Joint		
4	0176576	2	Bolt Bolzen	Perno Boulon		
5	0176577	1	Bolt Bolzen	Perno Boulon		
6	0176578	1	Return pipe Rückleitungsrohr	Tubo de retorno Tuyau de retour		
7	0176579	2	Hose clamp Schlauchschele	Abrazaderas de manguera Agrafe de tuyau		
8	0176580	1	Plug Stopfen	Tapón Bouchon		
9	0176581	1	Thermostat Temperaturregler	Termóstato Thermostat		
10	0176582	1	Thermostat cover Thermostatdeckel	Tapa del termóstato Couvercle du thermostat		
11	0176583	1	Gasket Dichtung	Junta Joint		
12	0176584	2	Bolt Bolzen	Perno Boulon		
13	0176585	1	Temperature sender Temperatursender	Transmisor de temperatura Transmetteur de température		

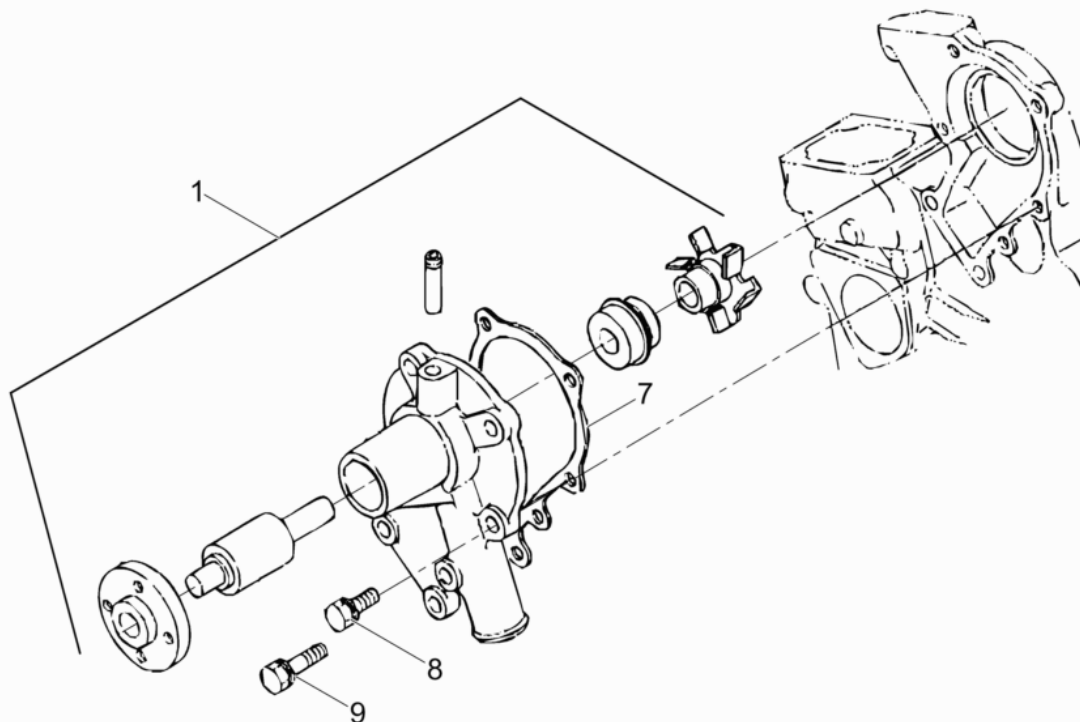

ghiex0168754100_13

Ref. Pos.	Part No. Artikel Nr.	Qty. St.	Description Beschreibung	Descripción Description	Measurem./Abm.	Norm
					Torque/Drehm.	Sealant Schmierstoff
1	0176586	1	Water Pump Kit Wasserpumpe kompl	Bomba del agua compl. Pompe à eau compl.		
7	0176587	1	Gasket Dichtung	Junta Joint		
8	0176588	5	Bolt Bolzen	Perno Boulon		
9	0176589	2	Bolt Bolzen	Perno Boulon		

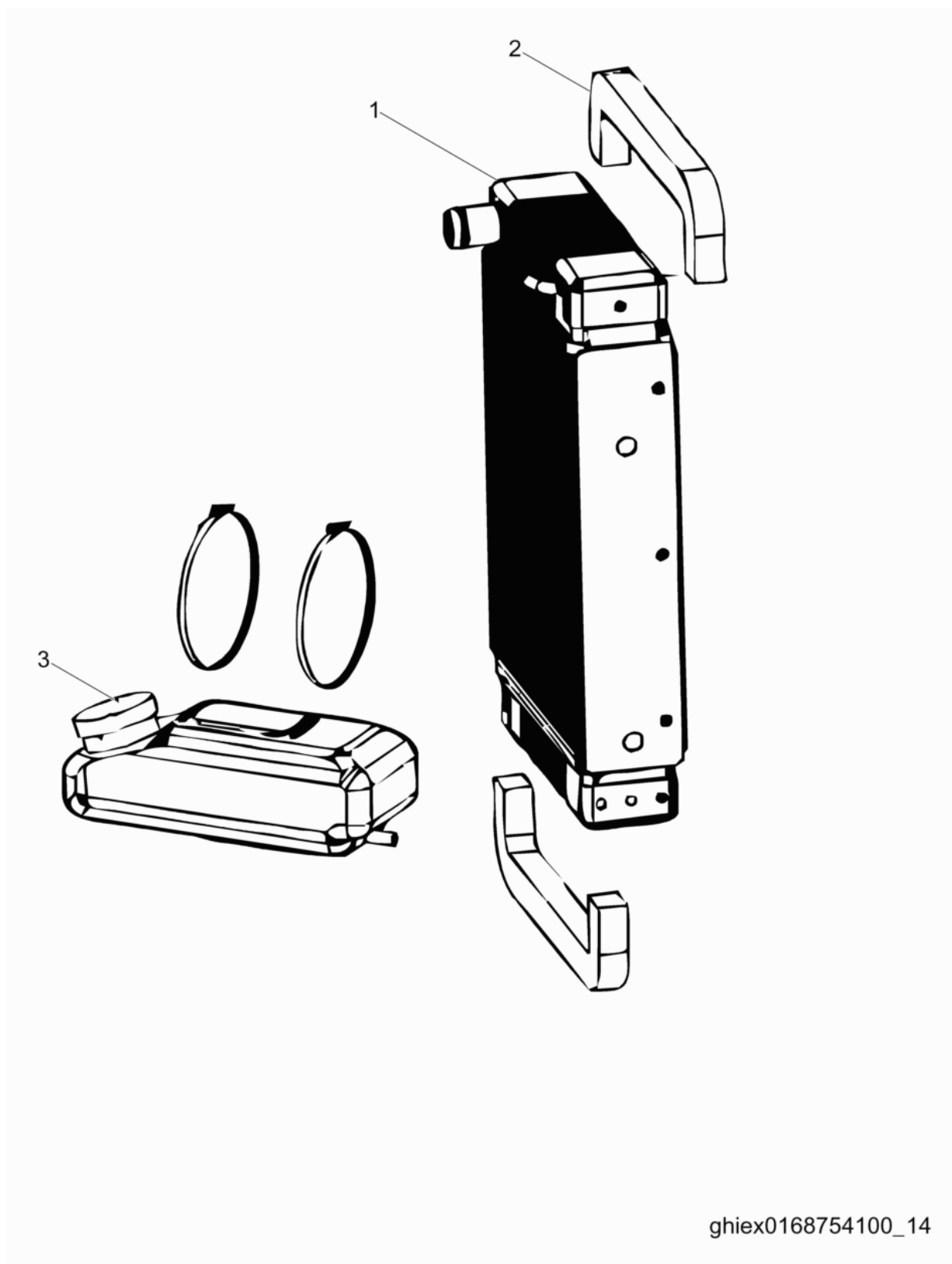

ghiex0168754100_14

Ref. Pos.	Part No. Artikel Nr.	Qty. St.	Description Beschreibung	Descripción Description	Measurem./Abm.	Norm
					Torque/Drehm.	Sealant Schmierstoff
1	0176590	1	Radiator Kühler	Radiador Radiateur		
2	0176591	2	Seal Dichtung	Empaque Joint		
3	0176592	1	Reservoir tank Tankbehälter	Tanque del depósito Réservoir		

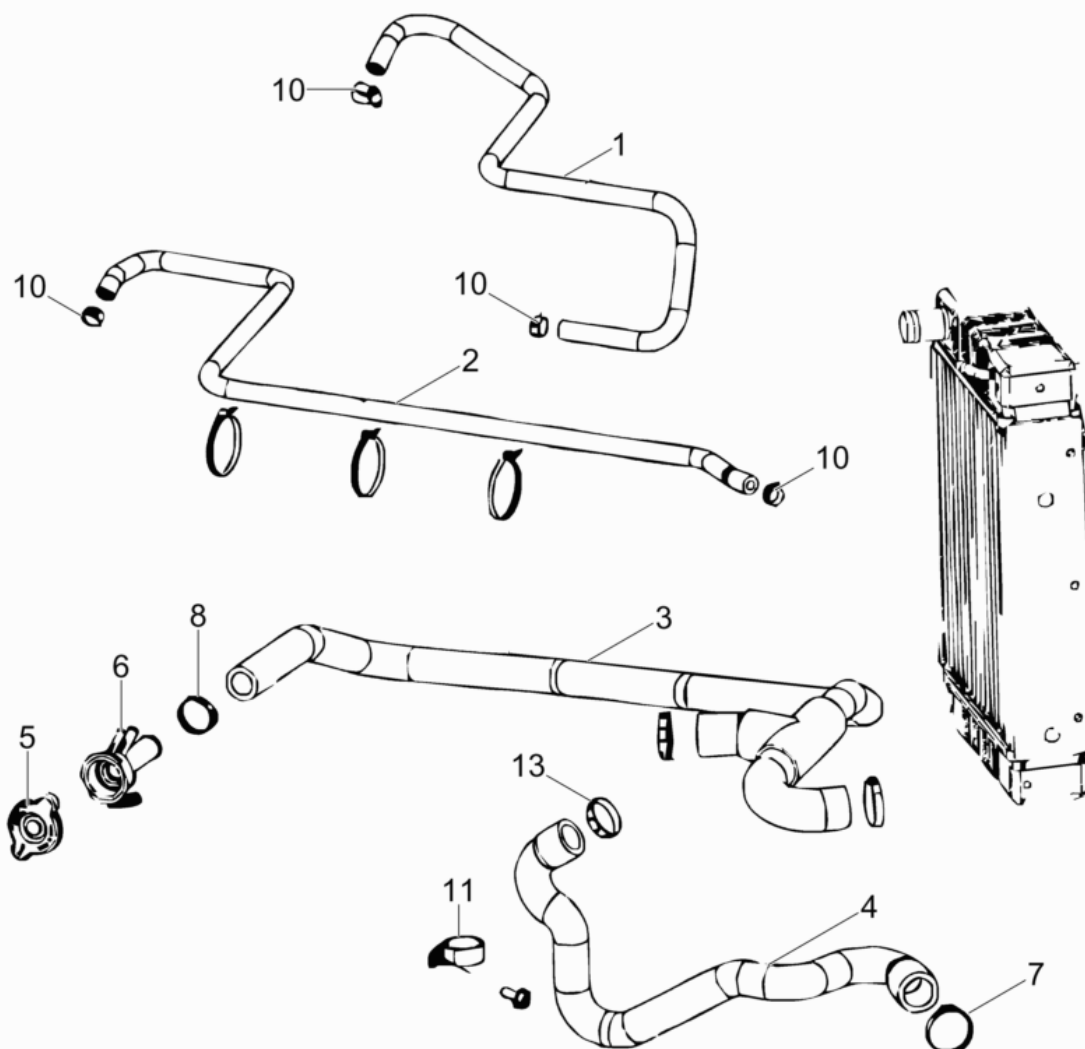

ghiex0168754100_15

Ref. Pos.	Part No. Artikel Nr.	Qty. St.	Description Beschreibung	Descripción Description	Measurement./Abm.	Norm
					Torque/Drehm.	Sealant Schmierstoff
1	0176596	1	Air hose Druckluftschlauch	Manguera de aire Tuyau à air		
2	0176597	1	Air hose Druckluftschlauch	Manguera de aire Tuyau à air		
3	0176598	1	Hose Schlauch	Manguera Tuyau		
4	0176599	1	Hose Schlauch	Manguera Tuyau		
5	0169162	1	Cap-coolant fill Kappe	Tapa Capuchon		
6	0176601	1	Filler tube Füllrohr	Tubo de llenado Tube de remplisseur		
7	0176602	3	Hose clamp Schlauchselle	Abrazaderas de manguera Agrafe de tuyau		
8	0176603	1	Hose clamp Schlauchselle	Abrazaderas de manguera Agrafe de tuyau		
10	0176604	4	Hose clamp Schlauchselle	Abrazaderas de manguera Agrafe de tuyau		
11	0176605	1	Cable clamp Kabelhalter	Abrazadera para cable Attache de câble		
13	0176606	1	Hose clamp Schlauchselle	Abrazaderas de manguera Agrafe de tuyau		

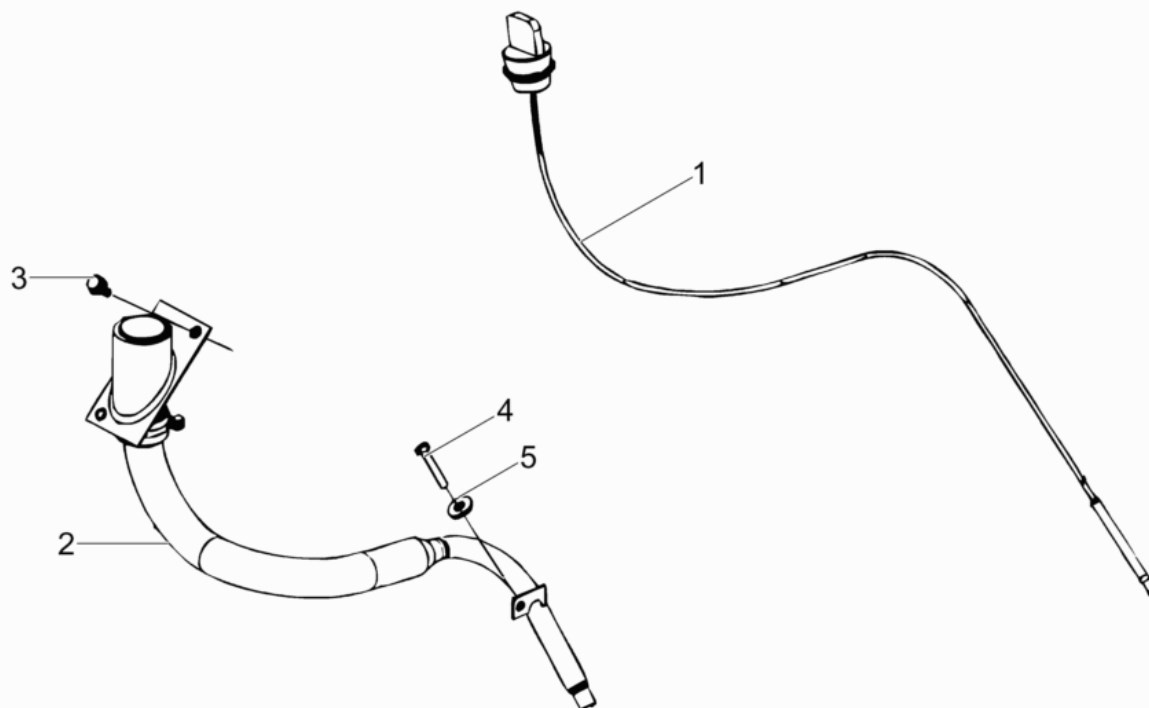

ghiex0168754100_17

Ref. Pos.	Part No. Artikel Nr.	Qty. St.	Description Beschreibung	Descripción Description	Measurement/Abm.	Norm
					Torque/Drehm.	Sealant Schmierstoff
1	0170467	1	Dipstick Peilstab	Indicador del nivel de aceite Réglette-jauge		
2	0176608	1	Oil fill tube Ölfüllerrohr	Tubo llenador de aceite Tube-remplisseur d'huile		
3	0176632	2	Screw w/lockwasher Schraube mit Federring	Tornillo con arandela elástica Vis avec rondelle de ressort		
4	0176610	1	Hex head screw Sechskantschraube	Tornillo Vis à tête hexagonale		
5	0176611	1	Flat washer Scheibe	Arandela elástica Rondelle de ressort		

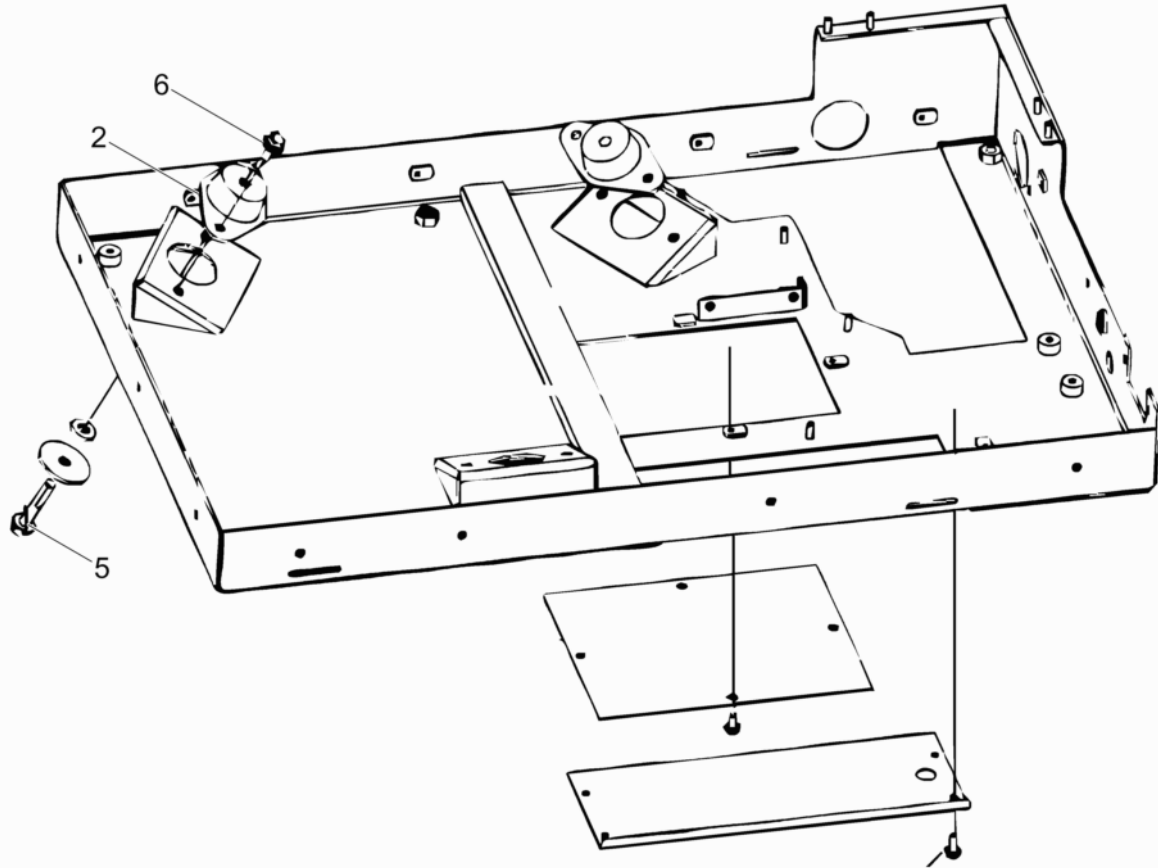

ghiex0168754100_19

Ref. Pos.	Part No. Artikel Nr.	Qty. St.	Description Beschreibung	Descripción Description	Measurement./Abm.	Norm
					Torque/Drehm.	Sealant Schmierstoff
2	0176613	3	Isolator pad Unterlage des Isolators	Cojín del aislador Coussin de l'isolant		
5	0176614	3	Threaded bolt Schraubbolzen	Perno roscado Boulon fileté	M10 x 1	
6	0176615	6	Hex head screw Sechskantschraube	Tornillo Vis à tête hexagonale	M8 x 1	

Exhaust manifold

Auspuffkrümmer

Distribuidor de escape

Collecteur d'échappement

HSH 650

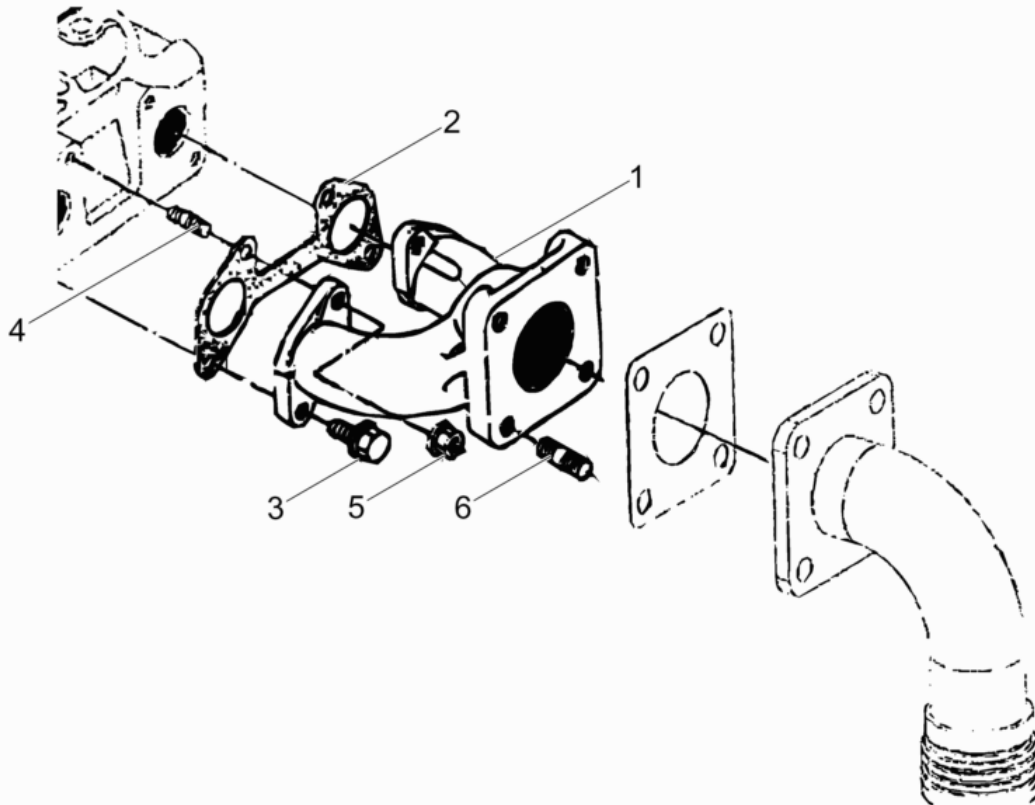

ghiex0168754100_20

Ref. Pos.	Part No. Artikel Nr.	Qty. St.	Description Beschreibung	Descripción Description	Measurement./Abm.	Norm
					Torque/Drehm.	Sealant Schmierstoff
1	0176616	1	Exhaust manifold Auspuffkrümmer	Distribuidor de escape Collecteur d'échappement		
2	0176617	1	Gasket Dichtung	Junta Joint		
3	0176618	2	Bolt Bolzen	Perno Boulon		
4	0176619	2	Stud Gewindebolzen	Perno prisionero Goujon		
5	0176620	2	Nut Mutter	Tuerca Écrou		
6	0176621	4	Stud Gewindebolzen	Perno prisionero Goujon		

Muffler cpl.
Auspufftopf kpl.

HSH 650

Silenciador compl.
Pot d'Echappement compl.

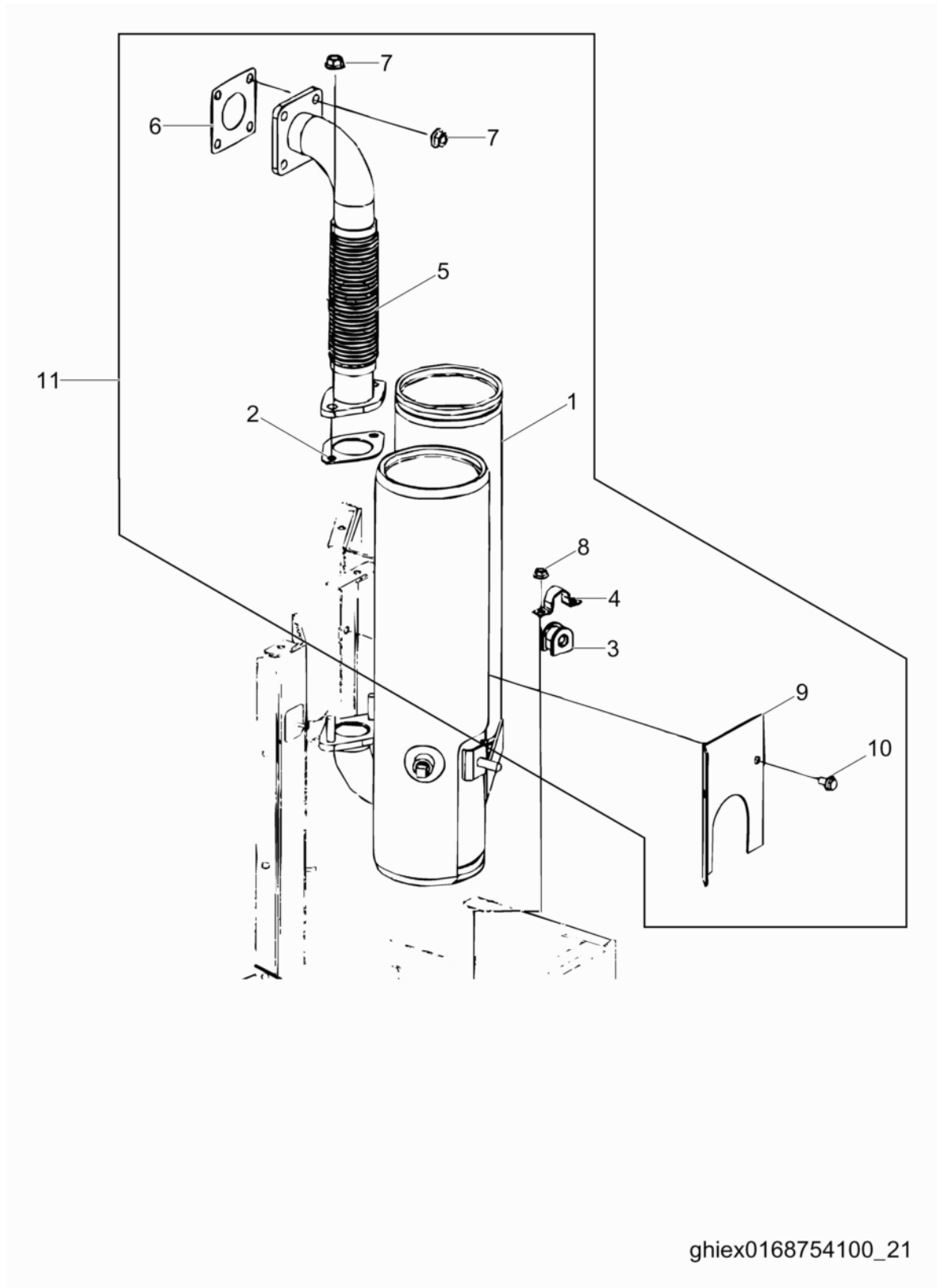

ghiex0168754100_21

Ref. Pos.	Part No. Artikel Nr.	Qty. St.	Description Beschreibung	Descripción Description	Measurem./Abm.	Norm
					Torque/Drehm.	Sealant Schmierstoff
1	0176623	1	Muffler Auspufftopf	Silenciador Pot d'échappement		
2	0176624	1	Gasket Dichtung	Junta Joint		
3	0176625	1	Isolator mount Isolatorkonsole	Ménsula de aislante Support d'isolant		
4	0176626	1	Clamp Schelle	Abrazadera Agrafe		
5	0176627	1	Exhaust pipe Auspuffrohr	Tubo de escape Tuyau d'échappement		
6	0176628	1	Gasket Dichtung	Junta Joint		
7	0176629	6	Hex nut Sechskantmutter	Tuerca hexagonal Écrou six-pans		
8	0176630	2	Hex nut Sechskantmutter	Tuerca hexagonal Écrou six-pans		
9	0176631	1	Bracket Konsole	Soporte Support		
10	0176632	2	Screw w/lockwasher Schraube mit Federring	Tornillo con arandela elástica Vis avec rondelle de ressort		
11	0176622	1	Muffler Kit Satz-Auspufftopf	Juego-silenciador Jeu-pot d'échappement		

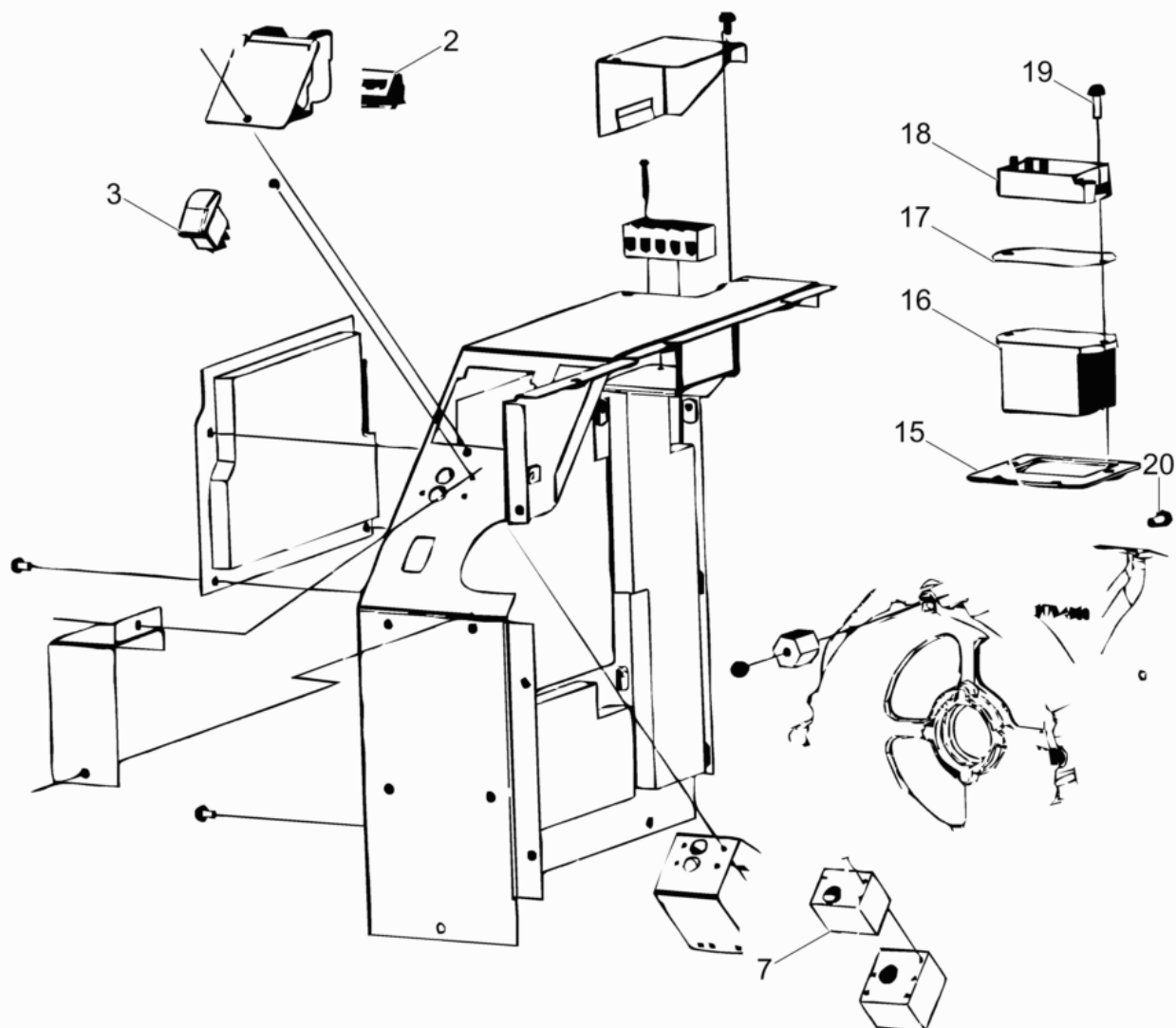

ghiex0168754100_23

Ref. Pos.	Part No. Artikel Nr.	Qty. St.	Description Beschreibung	Descripción Description	Measurement/Abm.	Norm
					Torque/Drehm.	Sealant Schmierstoff
2	0176634	1	Hour meter Stundenzähler	Horometro Compteur horaire		
3	0169172	1	Switch Schalter	Interruptor Interrupteur		
7	0176635	1	Circuit breaker Unterbrecher	Interruptor de circuito Coupe-circuit		
15	0176636	1	Bracket Konsole	Soporte Support		
16	0176637	1	Heat sink Kühlblock	Dispensor de calor Dissipateur de chaleur		
17	0176638	1	Pad Unterlage	Cojín Coussin		
18	0169315	1	Voltage regulator Spannungsregler	Regulador de voltaje Régulateur de tension		
19	0176639	2	Screw w/lockwasher Schraube mit Federring	Tornillo con arandela elástica Vis avec rondelle de ressort		
20	0176640	1	Screw w/locknut Schraube mit Sicherungsmutter	Tornillo con contratuerca Vis avec contre-écrou		

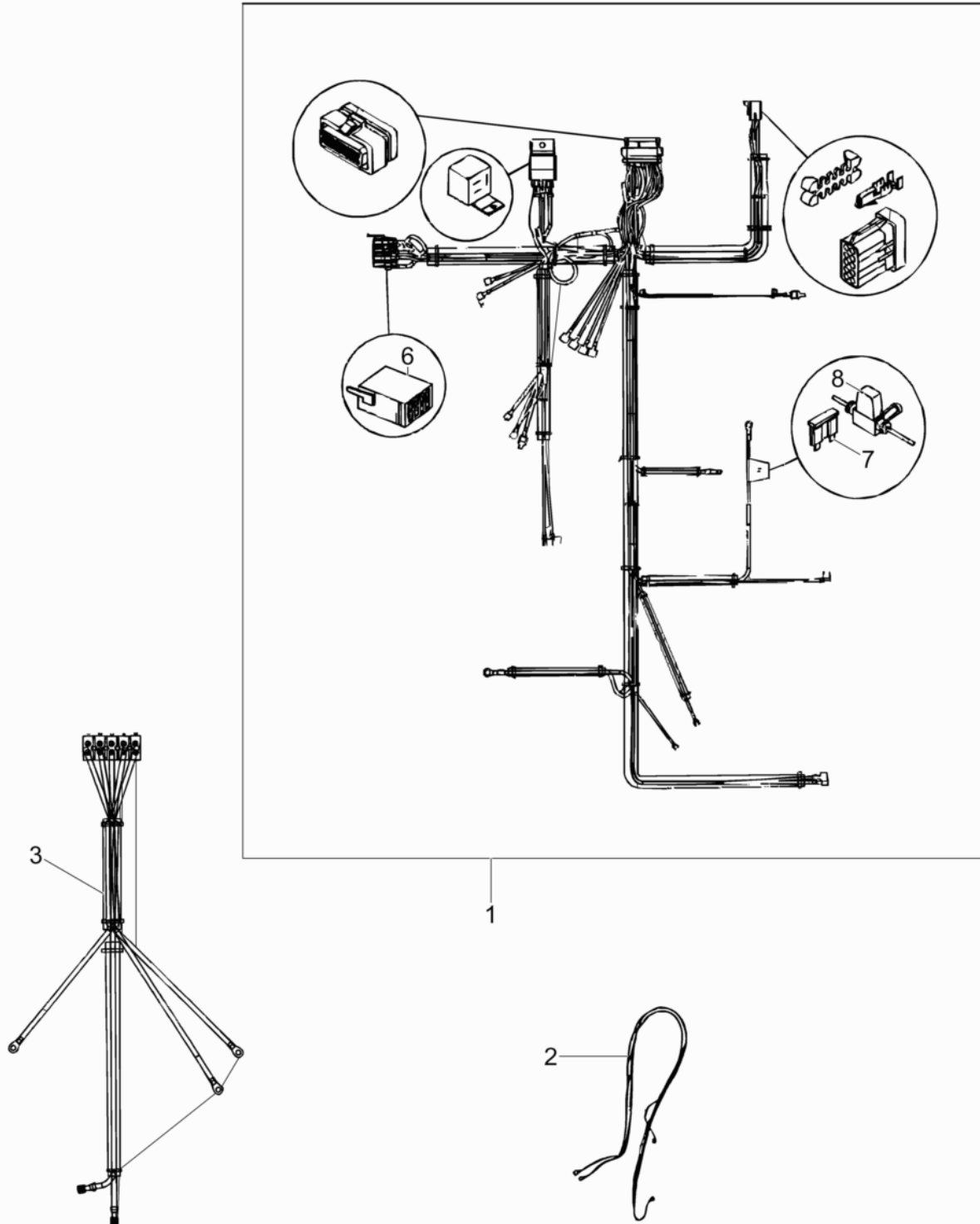

ghiex0168754100_25

Ref. Pos.	Part No. Artikel Nr.	Qty. St.	Description Beschreibung	Descripción Description	Measurement./Abm.	Norm
					Torque/Drehm.	Sealant Schmierstoff
1	0176641	1	Wiring harness Kabelbaum	Conjunto de cables Harnais de câbles électriques		
2	0176645	1	Wiring harness Kabelbaum	Conjunto de cables Harnais de câbles électriques		
3	0176644	1	Wiring harness Kabelbaum	Conjunto de cables Harnais de câbles électriques		
6	0169170	1	Switch Schalter	Interruptor Interrupteur		
7	0176642	1	Fuse Sicherung	Fusible Fusible	30A	
8	0176643	1	Fuse holder Fassung der Sicherung	Portafusible Porte-fusible		



**WACKER
NEUSON**