



**WACKER
NEUSON**

0620243	102
01.2013	

**Hydronic Surface Heaters
Hydronic Boden-, Flächenheizer
Calentadores de superficie hid
Réchauffeurs hydroniques par s**

HSH 700G

**Parts Book
Ersatzteile
Lista de Repuestos
Liste de Pièces de Rechange**

www.wackerneuson.com

A nameplate listing the Model Number, Item Number, Revision, and Serial Number is attached to each unit. Please record the information found on this plate so it will be available should the nameplate become lost or damaged. When ordering parts or requesting service information, you will always be asked to specify the model, item number, revision number, and serial number of the unit.

Ein Typenschild mit Typ, Artikelnummer, Version und Maschinen-Nummer ist an jedem Gerät angebracht. Die Daten von diesem Schild bitte notieren, damit sie auch bei Verlust oder Beschädigung des Schildes noch vorhanden sind. Der Typ, die Artikel-Nummer, die Versions- Nummer und die Maschinen-Nummer sind bei der Ersatzteilbestellung oder Nachfragen bezüglich Service-Informationen stets erforderlich.

Una placa de identificación con el modelo, número de referencia, nivel de revisión y número de serie ha sido añadida en cada máquina. Favor de anotar los datos en la placa en caso de que la placa de identificación sea destruida o perdida. En todos los pedidos para repuestos necesita siempre el modelo, el número de referencia, el nivel de revisión y el número de serie de la máquina en cuestión.

Une plaque signalétique mentionnant le modèle, le numéro de référence, le niveau de révision et le numéro de série est fixée sur chaque machine. Veuillez noter les informations relevées sur cette plaque de façon à ce qu'elles soient toujours disponibles si la plaque signalétique venait à être perdue ou endommagée. Lorsque vous commandez des pièces détachées ou vous sollicitez des informations après-vente, on vous demandera toujours de préciser le modèle, le numéro de référence, le niveau de révision et le numéro de série de la machine.

***My machine's numbers are / Die Nummern meines Gerätes sind /
Los números de mi máquina son / Les numéros de ma machine son :***

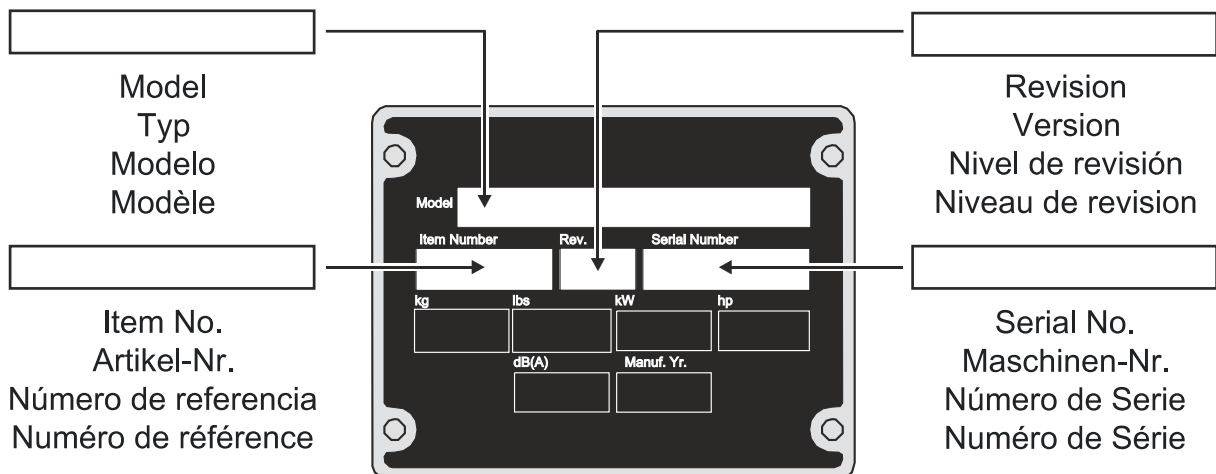

Part Numbers appearing in boldface type are recommended spare parts. This means that these parts are subject to wear under normal operating conditions and may require periodic service or replacement. It is recommended that these items be stocked to meet the expected service requirements of this model. Actual stocking quantities of these and other parts used in more extensive repairs will depend on the service practices of each customer.

Bei den in den Ersatzteillisten fettgedruckten Nummern handelt es sich um empfohlene Ersatzteile. Dies bedeutet, daß diese Teile bei normalen Anwendungsbedingungen natürlicher Abnutzung ausgesetzt sind und gelegentlich ersetzt oder überarbeitet werden müssen. Es wird geraten, diese Teile auf Lager bereit zu haben, um für Service-Arbeiten an diesem Gerät vorbereitet zu sein. Lagerbestände für diese und andere Teile, welche für ausgiebigere Reparaturarbeiten benötigt werden, können je nach Service-Gewohnheiten der einzelnen Kunden variieren.

Los números de partes en negritas en las Listas Ilustradas de Partes son los repuestos recomendados, ésto quiere decir que estas partes se desgastarán bajo circunstancias de funcionamiento normales y pueden requerir servicio periódico o su reemplazo. Se recomienda que el cliente mantenga un abastecimiento adecuado de estas partes para poder satisfacer la demanda requerida por el servicio a la máquina. La cantidad de repuestos que el cliente necesitará para reparaciones dependerá de la póliza de servicio de cada cliente.

Les numéros de pièces imprimés en caractères gras dans les Listes des Pièces Détachées de ce manuel sont les pièces détachées recommandées par la Wacker. Cela veut dire que ces pièces sont sujettes à usure dans des conditions de travail normales et peuvent nécessiter de l'entretien ou leur remplacement. Nous recommandons que vous disposez d'un stock de ces pièces pour pouvoir satisfaire la demande d'entretien de cette machine. Le client doit décider lui-même de la quantité exacte de pièces de rechange qu'il disposera dans ses stocks.

Service Parts Ersatzteile Repuestos Pièces Détachées	8
Front Enclosure cpl. Gehäuse Komplett Vorne Conjunto Caja Delantero Carter de Front	10
Upper Enclosure cpl. Oberes Gehäuse kpl. Carcasa Superior compl. Carter Supérieur compl.	14
Rear Enclosure cpl. Gehäuse Komplett (hinten) Conjunto Caja (de atrás) Carter (arrière)	18
Left Side Enclosure cpl. Gehäuse Komplett (links) Conjunto Caja (de izquierdo) Carter (gauche)	20
Heater cpl. Heizung, kpl. Calentador, acopl. Réchauffeur compl.	22
Hydronic Heater cpl. Wärmeübertragende Heizung, kpl. Calentador hidrónico, acopl. Réchauffeur caloporteur compl.	28
Reservoir/Piping Behälter/Verrohrung Depósito/tubería Réservoir/conduit	30
Pump and motor cpl. Pumpe und Motor, kpl. Bomba y motor, acopl. Pompe et moteur compl.	34
Hose Reel cpl. Schlauchhaspel, kpl. Carrete de la manguera compl. Dévidoir enrouleur compl.	36
Genset Enclosure cpl. Genset-Gehäuse, kpl. Armario generador compl. Groupe électrogène compl.	42
Generator Service Parts Generatorenersatzteile Repuestos para Generadores Pièces Détachées des Groupes Électrogènes	44
Control Panel cpl. Betätigung kpl. Regulador compl. Commande compl.	46
Burner cpl. Brenner, kpl. Quemador, acopl. Brûleur compl.	48

Indice**Table des matières**

Electrical Components Elektrische Bestandteile Piezas Eléctricas Parties Constituanates Électriques	52
Electrical Components Elektrische Bestandteile Piezas Eléctricas Parties Constituanates Électriques	56
Internal Labels Interne Aufkleber Calcomanías internas Autocollants intérieures	58
External Labels Externe Aufkleber Calcomanías externas Autocollants externes	60
Generator Service Parts Generatorenersatzteile Repuestos para Generadores Pièces Détachées des Groupes Électrogènes	63
Service Parts Ersatzteile Repuestos Pièces Détachées	64
Nozzle body (holder) Düse Tobera Ajutage	66
Cylinder Head Cover Zylinderkopfhaube Tapa del Cilindro Couvercle Supérieur	68
Flywheel Schwungrad Volante Volant	70
Generator Service Parts Generatorenersatzteile Repuestos para Generadores Pièces Détachées des Groupes Électrogènes	72
Fuel System Kraftstoffsystem Sistema de Combustible Système d'Essence	74
Manifold inlet Verteiler, Einlass Distribuidor, admisión Tubulure, admission	76
Air intake Ansaugstutzen Tubuladura de aspiración Tubulure d'aspiration	78
Water Manifold Wasser-Verteiler Distribuidor del agua Rampe d'arrosage	80

Water pump Wasserpumpe Bomba del agua Pompe à eau	82
Radiator Section cpl. Kühleranlage Conjunto Sector Radiateur Radiateur Compl.	84
Cooling System Kühlungssystem Sistema de Enfriamiento Système de Refroidissement	86
Oil dipstick Ölpeilstab Indicador del nivel de aceite Réglette-jauge d'huile	88
Vibration Reduction Kit Vibrationsverringersatz Juego reductor de vibración Jeu de ralentissement de vibration	90
Exhaust manifold Auspuffkrümmer Distribuidor de escape Collecteur d'échappement	92
Muffler cpl. Auspufftopf kpl. Silenciador compl. Pot d'Echappement compl.	94
Control Box Kontrollkasten Caja de Control Boîtier de Commande	96
Electrical Components Elektrische Bestandteile Piezas Eléctricas Parties Constituanates Électriques	98



ghiex0000000000_01

Ref. Pos.	Part No. Artikel Nr.	Qty. St.	Description Beschreibung	Descripción Description	Measurement./Abm.	Norm
					Torque/Drehm.	Sealant Schmierstoff
1	0170579	1	Meter-combustion analyzer Zähler-Verbrennungsanalysator	Medidor-analizador de combustión Appareil de mesure - analyseur de combustion		
2	0169002	1	Hose crimper Schlauch Crimper	Manguera arrugador Sertisseuse tuyau		
3	0168953	1	Fuel pressure test kit Druckprobensatz	Juego de prueba de presión Jeu d'essai de pression		
4	0168949	1	Brush Kohlenbürste	Escobilla Balai de charbon		
5	0168954	1	Smoke spot tester Rußpunkttester	Probador de manchas de humo Testeur de tache de fumée		
6	0168042	50	Hose ferrule Schlauchzwinge	Férula de manguera Bague de flexible	0.975in ID	
7	0168271	25	Hose mender Schlauchblech	Reparador de manguera Jeu de réparation de flexible	5/8 x 5/8in	
8	0169435	2	Hose Schlauch	Manguera Tuyau	200psi	
9	0175837	1	Heat transfer fluid Wärmetransferflüssigkeit	Líquido de transferencia de calor Fluide caloporteur	215L	
9	0175836	1	Heat transfer fluid Wärmetransferflüssigkeit	Líquido de transferencia de calor Fluide caloporteur	10L	
10	0172649	1	Adapter Adapter	Adaptador Raccord		

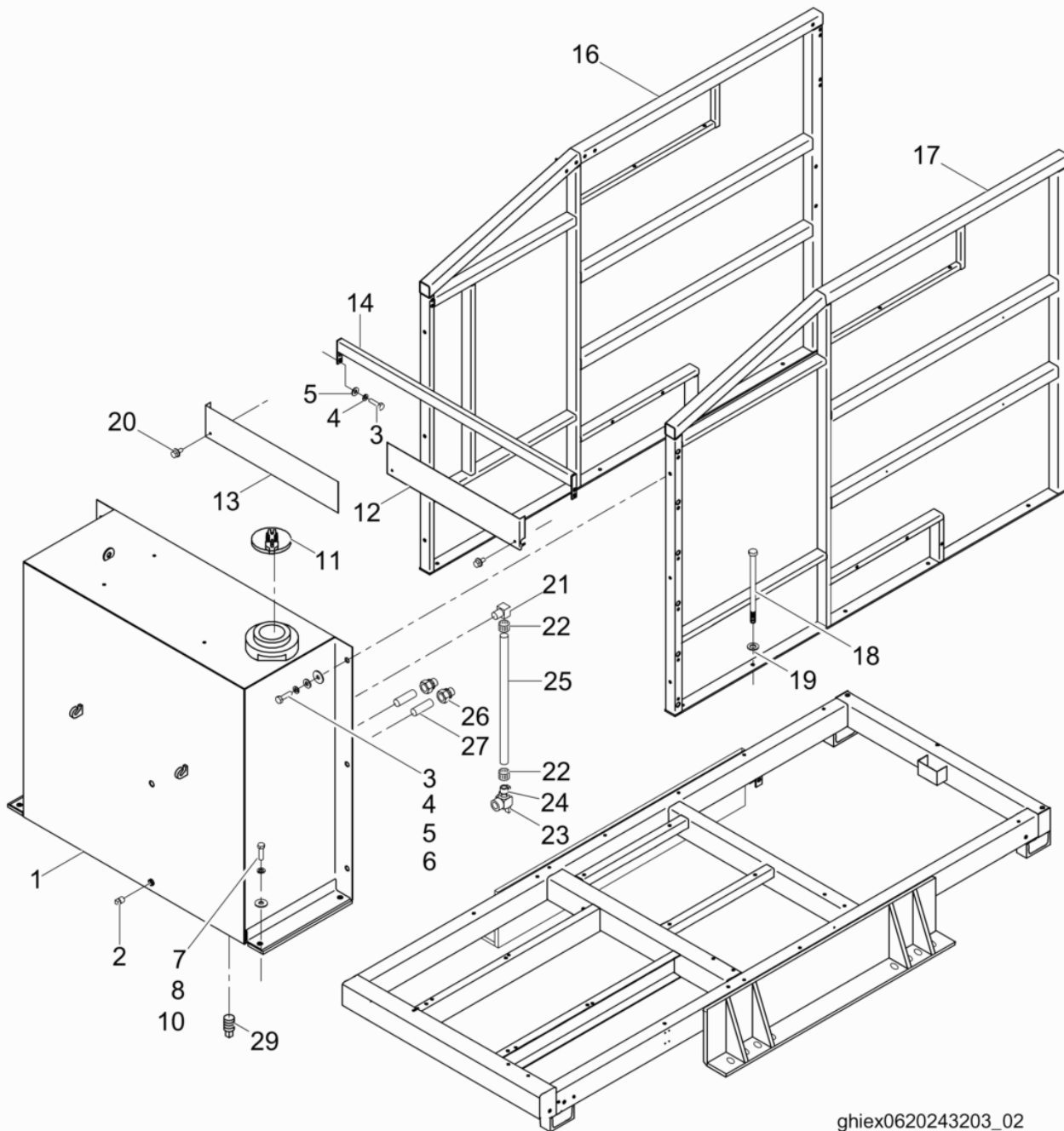

ghiex0620243203_02

Ref. Pos.	Part No. Artikel Nr.	Qty. St.	Description Beschreibung	Descripción Description	Measurement/Abm.	Norm
					Torque/Drehm.	Sealant Schmierstoff
1	0169565	1	Fuel tank Kraftstofftank	Depósito de combustible Réservoir de carburant		
2	0168235	1	Plug Stopfen	Tapón Bouchon	1/4in NPT	
3	0167721	10	Bolt Bolzen	Perno Boulon	1/4-20 x 1in	
4	0167733	14	Lock washer Federring	Federring Rondelle de ressort	1/4in	
5	0167729	14	Flat washer Scheibe	Arandela elástica Rondelle de ressort	1/4in	
6	0167833	6	Fender washer Unterlegscheibe	Arandela Rondelle	1/4 x 1-1/4	
7	0167764	4	Bolt Bolzen	Perno Boulon	7/16 - 14 x 1 1/2in	
8	0167737	4	Washer-lock Federring	Arandela elástica Rondelle de ressort	7/16in	
10	0167808	4	Fender washer Unterlegscheibe	Arandela Rondelle	1/2 x 1-1/4	
11	0176369	1	Fuel tank cap Tankverschluß	Tapa del tanque Chapeau de réservoir		
12	0181004	1	Left Front Cover Kit Deckelsatz	Juego-tapa Jeu-couvercle		
13	0181030	1	Right Front Cover Kit Deckelsatz	Juego-tapa Jeu-couvercle		
14	0169566	1	Cross tube Spurstange	Cruceta Tube transversal		
16	0172062	1	Frame-right side weldment Rahmen	Chasis Châssis		
17	0172057	1	Frame-left side weldment Rahmen	Chasis Châssis		
18	0167720	10	Bolt Bolzen	Perno Boulon	3/8-16 x 6in	
19	0167730	8	Flat washer Scheibe	Arandela elástica Rondelle de ressort	3/8in	
20	0167722	4	Screw w/washer Schraube mit Scheibe	Tornillo con arandela Vis avec rondelle	10 x 3/4	
21	0168279	1	Barbed hose fitting Schlauchverschraubung mit Stecknippel	Unión de mangueras con púas Accouplement de tuyau avec raccord cannelé	3/8 x 1/4in	
22	0168282	2	Hose clamp Schlauchschelle	Abrazaderas de manguera Agrafe de tuyau		
23	0168281	1	Valve Ventil	Válvula Soupape		
24	0168280	1	Hose barb Schlauchwiderhaken	Púa de manguera Barbelure de flexible	3/8 x 1/4in	
25	0169400	1	Tubing Schläuche	Tubos Gaine	3/8in ID	
26	0168295	2	Coupling Kupplung	Acoplamiento Accouplement		

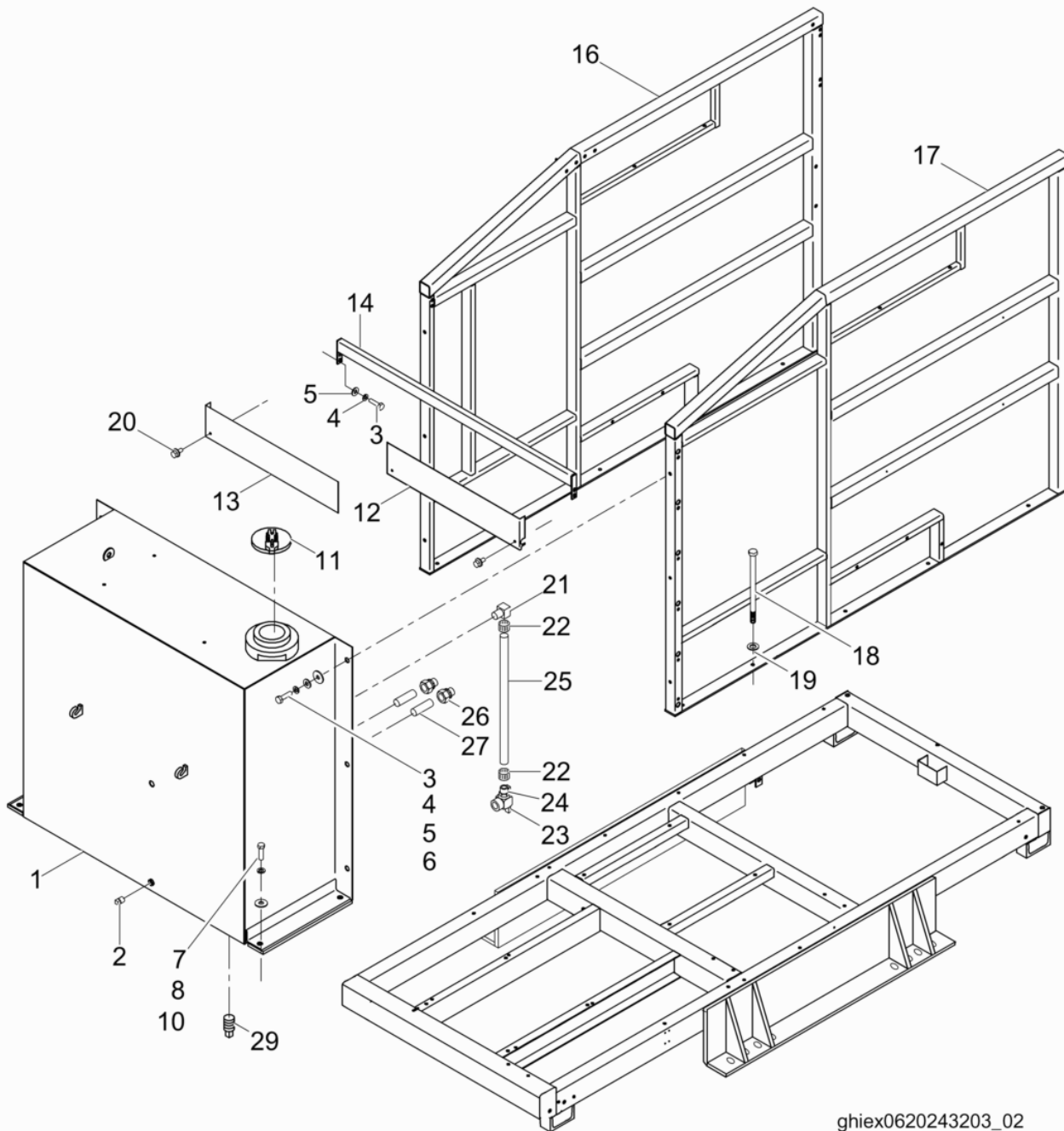

ghiex0620243203_02

Ref. Pos.	Part No. Artikel Nr.	Qty. St.	Description Beschreibung	Descripción Description	Measurem./Abm.	Norm
					Torque/Drehm.	Sealant Schmierstoff
27	0168489	2	Nipple fitting Stutzen	Niple Raccord	1/4 NPT x 2in	
29	0168154	1	Plug Stopfen	Tapón Bouchon	3/4in NPT	
167	0166239	1	Panel cpl. Panel kpl.	Panel compl. Tableau compl.		

Upper Enclosure cpl.
Oberes Gehäuse kpl.
Carcasa Superior compl.
Carter Supérieur compl.

HSH 700G

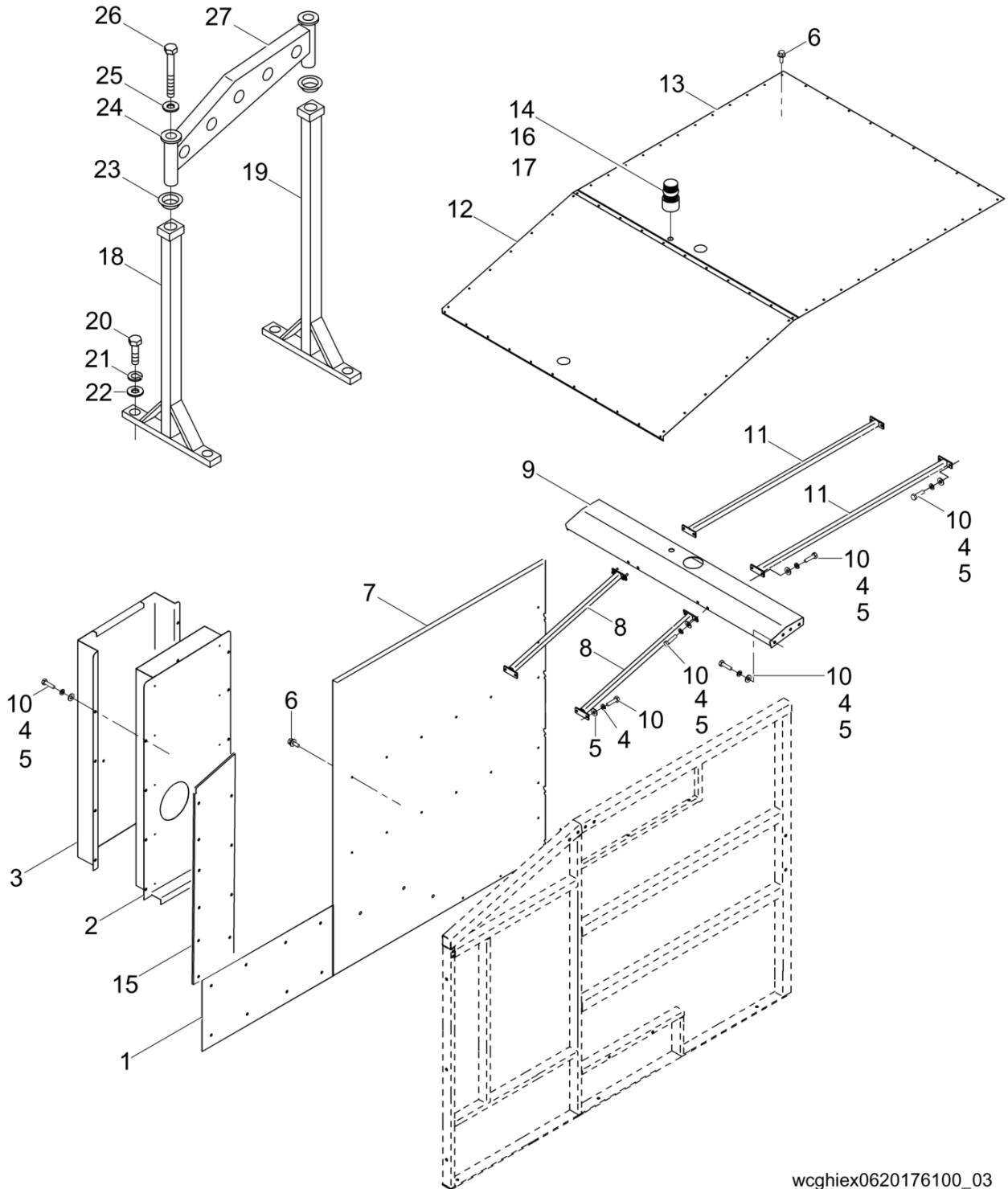

wcghiex0620176100_03

Ref. Pos.	Part No. Artikel Nr.	Qty. St.	Description Beschreibung	Descripción Description	Measurem./Abm.	Norm
					Torque/Drehm.	Sealant Schmierstoff
1	0181045	1	Right Side Below Exhaust Cover Kit Deckelsatz	Juego-tapa Jeu-couvercle		
2	0167144	1	Inner exhaust stack cpl. Innere Auspuffplatte	Placa de escape interna Plaque d'échappement interne		
3	0167127	1	Stack guard Schachtschutz	Protector del tubo Cheminée		
4	0167729	33	Flat washer Scheibe	Arandela elástica Rondelle de ressort	1/4in	
5	0167733	33	Lock washer Federring	Federring Rondelle de ressort	1/4in	
6	0167722	90	Screw w/washer Schraube mit Scheibe	Tornillo con arandela Vis avec rondelle	10 x 3/4	
7	0180219	1	Right Side Cover Kit Deckelsatz	Juego-tapa Jeu-couvercle		
8	0169572	2	Support Halter	Soporte Attache		
9	0169568	1	Brace Strebe	Apoyo Ventreire		
10	0167721	33	Bolt Bolzen	Perno Boulon	1/4-20 x 1in	
11	0169576	2	Support Halter	Soporte Attache		
12	0180217	1	Front Roof Cover Kit Deckelsatz	Juego-tapa Jeu-couvercle		
13	0181043	1	Rear Roof Cover Kit Deckelsatz	Juego-tapa Jeu-couvercle		
14	0166797	1	Light Lampe	Lámpara Lampe		
15	0181047	1	Right Side Front Corner CoverKit Deckelsatz	Juego-tapa Jeu-couvercle		
16	0166792	1	Plug Stopfen	Tapón Bouchon		
17	0166800	1	Cable Kabel	Cable Câble	16/3	
18	0169574	1	Lifting bail Hebegriff	Agarradero de izar D?anse de levage		
19	0169575	1	Lifting bail Hebegriff	Agarradero de izar D?anse de levage		
20	0167763	4	Bolt Bolzen	Perno Boulon	5/8-11 x 2in	
21	0167762	4	Washer-lock Federring	Arandela elástica Rondelle de ressort	5/8in	
22	0167760	4	Washer-flat Unterlegscheibe	Arandela plana Rondelle	5/8in	
23	0168522	2	Grommet Tülle	Ojal Passe-fil		
24	0167339	2	Disc Scheibe	Disco Disque		
25	0167855	2	Washer-lock Federring	Arandela elástica Rondelle de ressort	1in	

Upper Enclosure cpl.
Oberes Gehäuse kpl.
Carcasa Superior compl.
Carter Supérieur compl.

HSH 700G

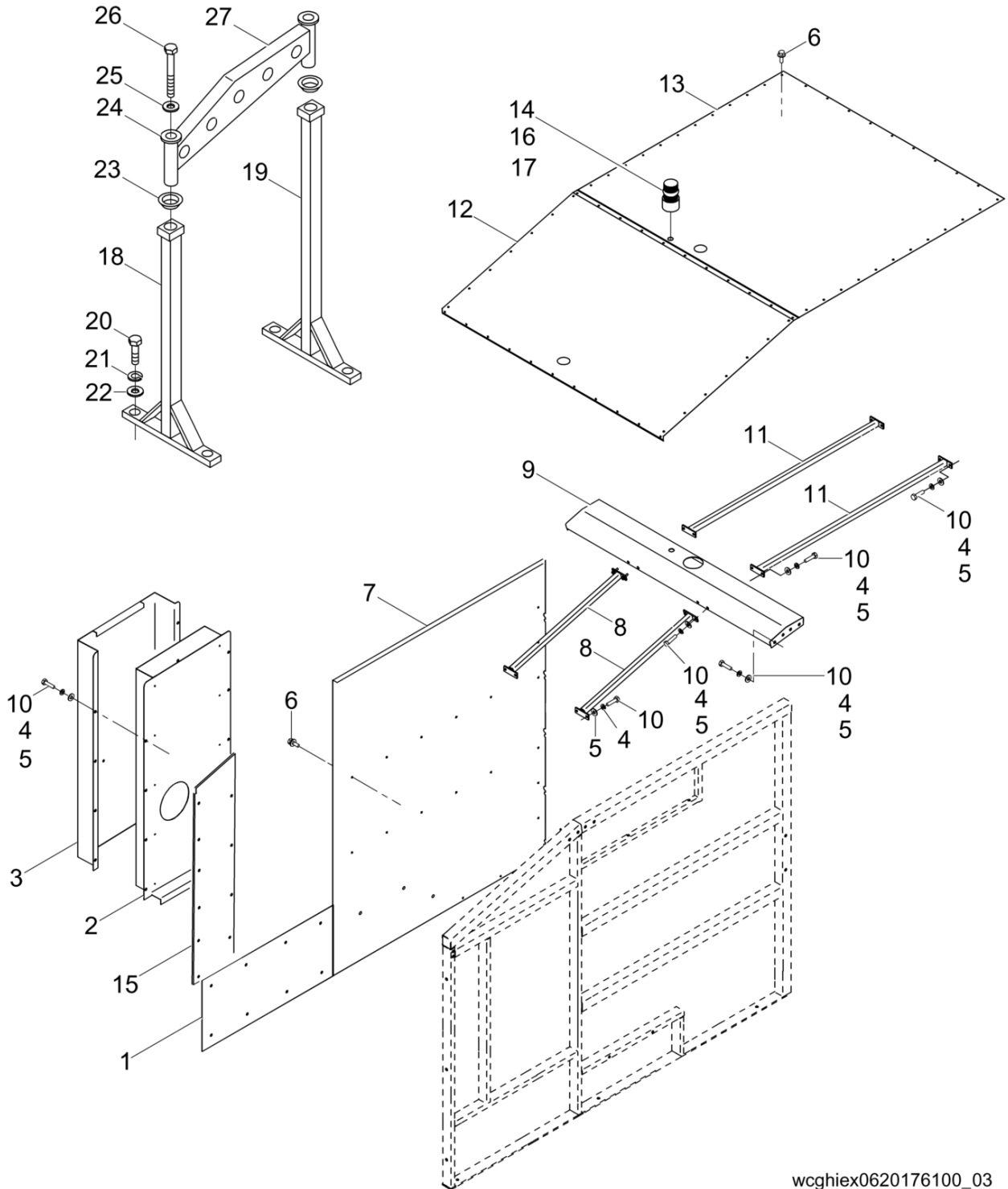

wcghiex0620176100_03

Ref. Pos.	Part No. Artikel Nr.	Qty. St.	Description Beschreibung	Descripción Description	Measurement./Abm.	Norm
					Torque/Drehm.	Sealant Schmierstoff
26	0167856	2	Bolt Bolzen	Perno Boulon	1-8 x 8in	
27	0169573	1	Lifting bail Hebegriff	Agarradero de izar D?anse de levage		

Rear Enclosure cpl.
Gehäuse Komplett (hinten)
Conjunto Caja (de atrás)
Carter (arrière)

HSH 700G

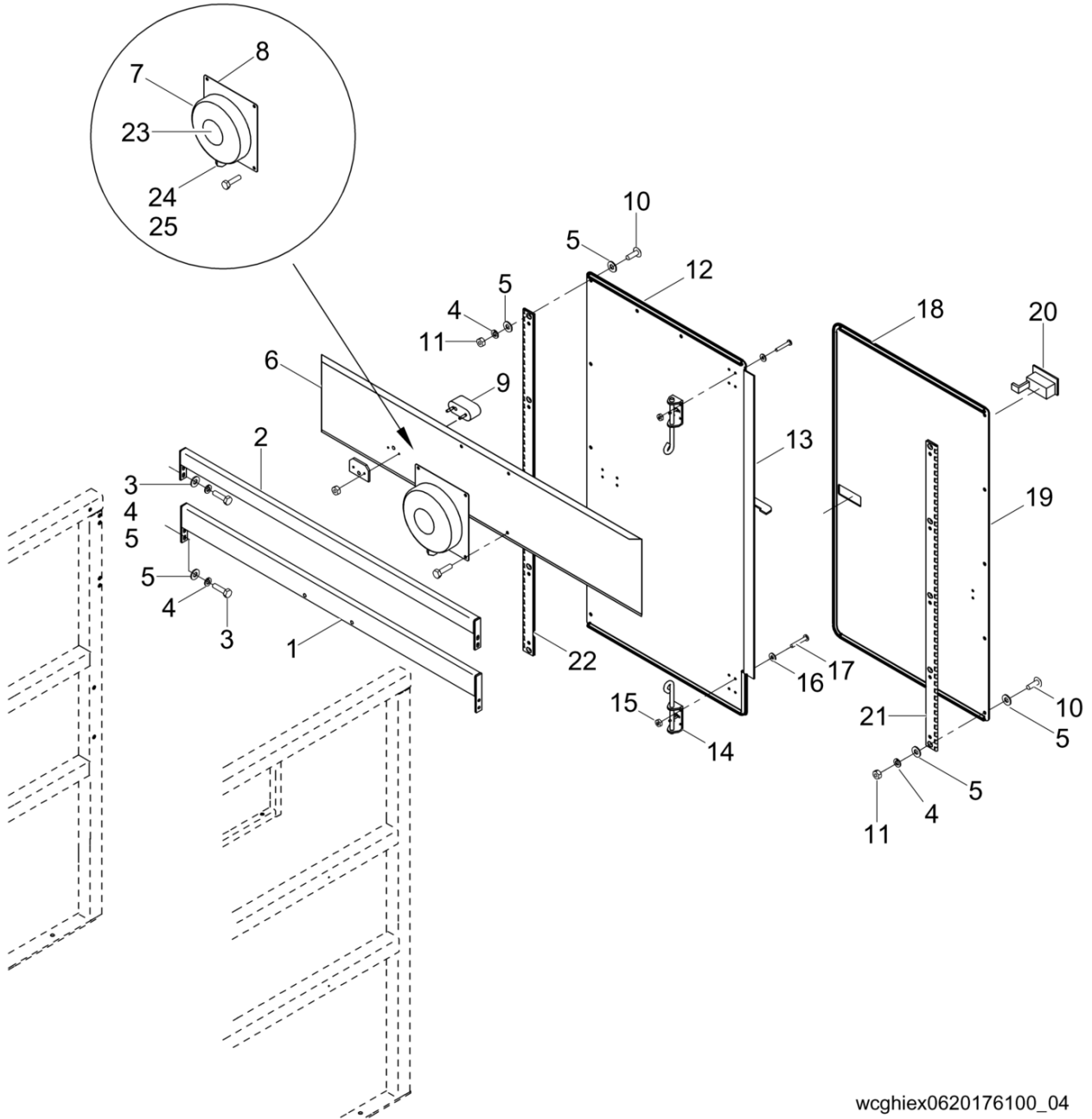

wcghiex0620176100_04

Ref. Pos.	Part No. Artikel Nr.	Qty. St.	Description Beschreibung	Descripción Description	Measurem./Abm.	Norm
					Torque/Drehm.	Sealant Schmierstoff
1	0169581	1	Cross tube Spurstange	Cruceta Tube transversal		
2	0169566	1	Cross tube Spurstange	Cruceta Tube transversal		
3	0167721	8	Bolt Bolzen	Perno Boulon	1/4-20 x 1in	
4	0167733	18	Lock washer Federring	Federring Rondelle de ressort	1/4in	
5	0167729	26	Flat washer Scheibe	Arandela elástica Rondelle de ressort	1/4in	
6	0181032	1	Above Rear Door Cover Kit Deckelsatz	Juego-tapa Jeu-couvercle		
7	0166793	1	Light fixture Licht	Artefacto Projecteur	50Hz	
8	0169682	1	Light bar bracket Konsole für Schlußleuchten	Soporte para barra de lámparas Support pour feux arrière		
10	0167857	10	Screw Schraube	Tornillo Vis	1/4-20 x 3/4	
11	0167690	10	Nut Mutter	Tuerca Écrou	1/4in - 20	
12	0168354	1	Trim Einfassung	Protección Garniture	12ft	
13	0180333	1	Rear right door Blechtafel hinten & rechts	Panel trasero y derecha Tableau d'arrière et à droite		
14	0168521	2	Spring Feder	Resorte Ressort		
15	0167814	8	Nut Mutter	Tuerca Écrou	8-32	
16	0167810	8	Washer-flat Unterlegscheibe	Arandela plana Rondelle	No. 8	
17	0167821	8	Screw Schraube	Tornillo Vis	No. 8-32 x 1	
18	0168354	1	Trim Einfassung	Protección Garniture	12ft	
19	0180332	1	Rear Left Door Linke Tür Hinten	Puerta Trasera Izquierda Porte-d'Arrière Gauche		
20	0168398	1	Latch Verriegelung	Aldaba Loquet		
21	0167348	1	Hinge Scharnier	Bisagra Charnière		
22	0167352	1	Hinge Scharnier	Bisagra Charnière		
23	0166794	1	Light bulb Glühlampe	Bombilla Ampoule	50HZ/230V, 42W	
24	0166458	1	Cord grip Zugentlastung	Alivio de esfuerzos Effort à la décharge	1/2in	
25	0166459	1	Lock nut Sicherungsmutter	Contratuerca Contre-écrou		

Left Side Enclosure cpl.
Gehäuse Komplett (links)
Conjunto Caja (de izquierdo)
Carter (gauche)

HSH 700G

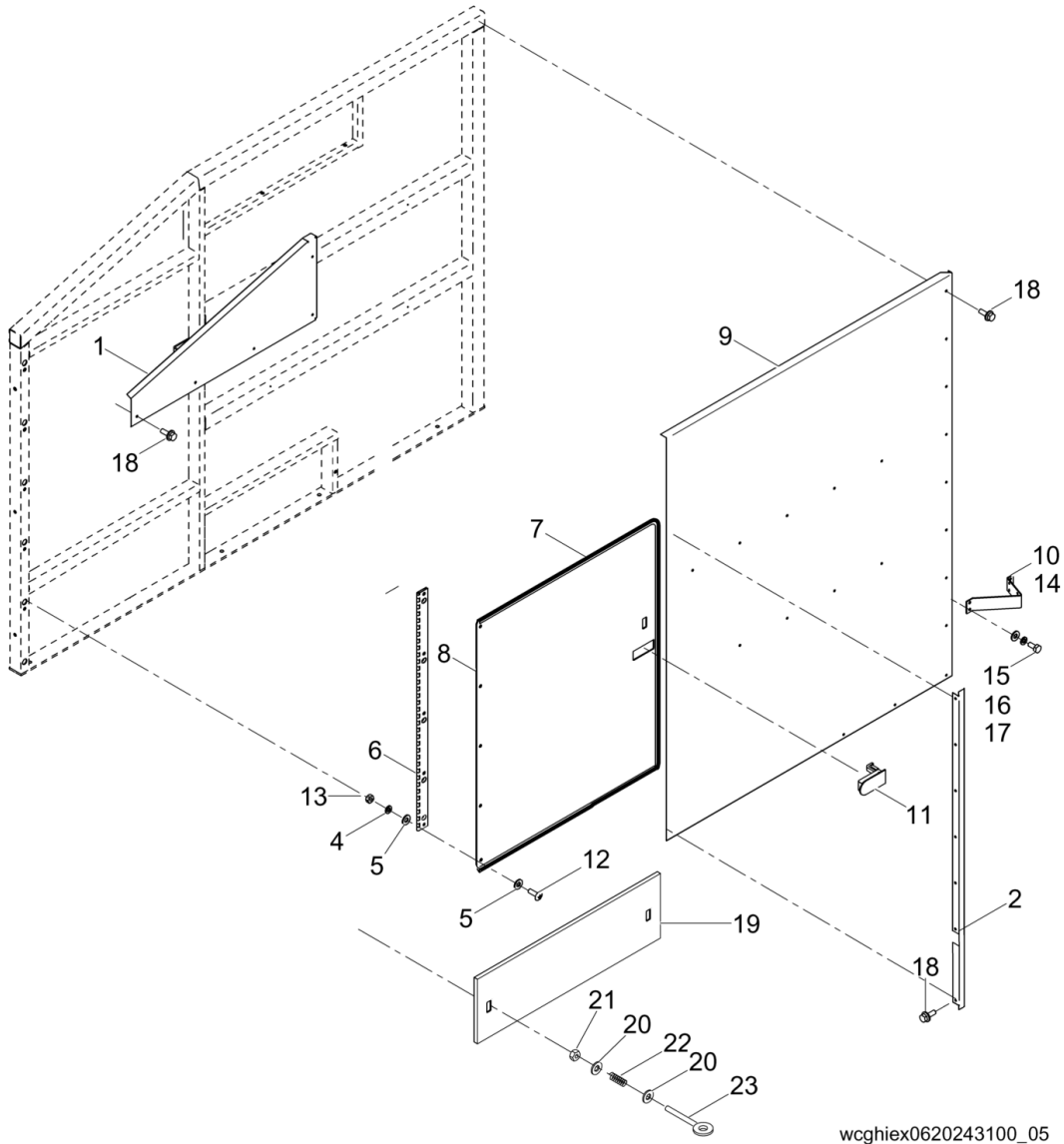

wcghiex0620243100_05

Ref. Pos.	Part No. Artikel Nr.	Qty. St.	Description Beschreibung	Descripción Description	Measurement/Abm.	Norm
					Torque/Drehm.	Sealant Schmierstoff
1	0180186	1	Left Side Above Door Cover Kit Deckelsatz	Juego-tapa Jeu-couvercle		
2	0180213	1	Left Side Door Corner Cover Kit Deckelsatz	Juego-tapa Jeu-couvercle		
4	0167733	18	Lock washer Federring	Federring Rondelle de ressort	1/4in	
5	0167729	26	Flat washer Scheibe	Arandela elástica Rondelle de ressort	1/4in	
6	0172056	1	Hinge Scharnier	Bisagra Charnière		
7	0168354	1	Trim Einfassung	Protección Garniture	12ft	
8	0180588	1	Left side door Linke Tür	Puerta costado izquierdo Porte gauche		
9	0180226	1	Left Side Cover Kit Deckelsatz	Juego-tapa Jeu-couvercle		
10	0179305	2	Bracket Konsole	Soporte Support		
11	0168398	1	Latch Verriegelung	Aldaba Loquet		
12	0167857	6	Screw Schraube	Tornillo Vis	1/4-20 x 3/4	
13	0167690	6	Nut Mutter	Tuerca Écrou	1/4in - 20	
14	0168402	2	Holder-door Halter	Soporte Attache		
15	0167709	16	Screw Schraube	Tornillo Vis	10-24 x 3/4	
16	0167788	16	Washer-flat Unterlegscheibe	Arandela plana Rondelle	No. 10	
17	0167688	16	Nut Mutter	Tuerca Écrou	10-24	
18	0167722	36	Screw w/washer Schraube mit Scheibe	Tornillo con arandela Vis avec rondelle	10 x 3/4	
19	0180227	1	Lower panel Unteres Panel	Panel inferior Panneau inférieur		
20	0167730	4	Flat washer Scheibe	Arandela elástica Rondelle de ressort	3/8in	
21	0167778	2	Nut Mutter	Tuerca Écrou	3/8in-16	
22	0167906	2	Spring Feder	Resorte Ressort		
23	0172375	2	Eye bolt Ösenschraubbolzen	Perno de argolla Boulon d'oeil	3/8-16 x 4in	

Heater cpl.
 Heizung, kpl.
 Calentador, acopl.
 Réchauffeur compl.

HSH 700G

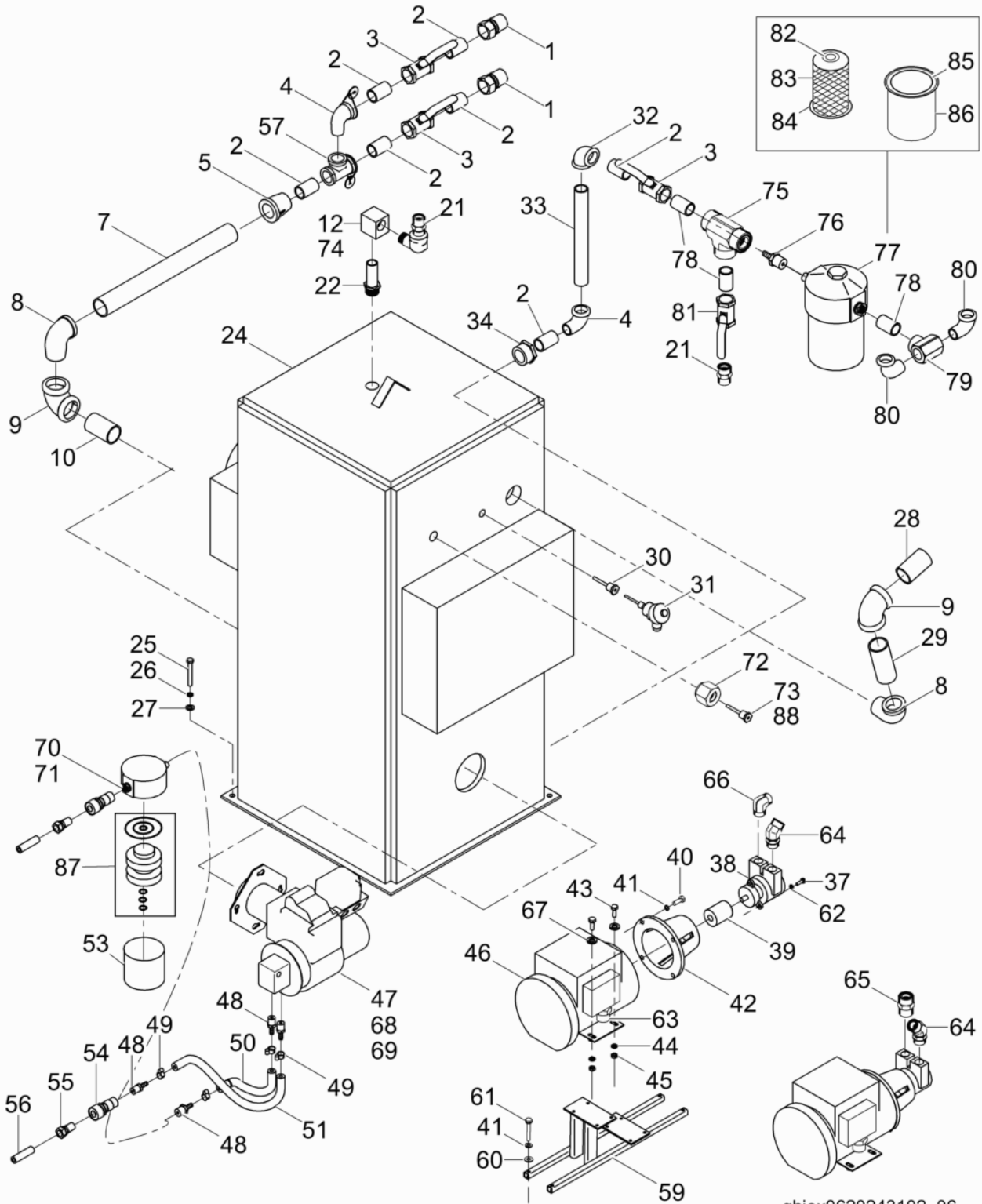

ghiex0620243102_06

Ref. Pos.	Part No. Artikel Nr.	Qty. St.	Description Beschreibung	Descripción Description	Measurem./Abm.	Norm
					Torque/Drehm.	Sealant Schmierstoff
1	0168385	2	Coupling Kupplung	Acoplamiento Accouplement	1 NPT	
2	0168331	7	Nipple fitting Stutzen	Niple Raccord	1 NPT x 2in	
3	0168330	3	Valve Ventil	Válvula Soupape		
4	0168403	2	Elbow fitting Rohrkrümmer	Codo Raccord coudé	1in	
5	0168634	1	Coupling Kupplung	Acoplamiento Accouplement		
7	0169413	1	Pipe Rohr	Tubo Conduit	1-1/2in	
8	0168030	2	Elbow Krümmer	Codo Coude	1-1/2in NPT	
9	0168459	2	Elbow Krümmer	Codo Coude	1 1/2in NPT	
10	0168707	1	Nipple fitting Stutzen	Niple Raccord	1.50 x 3in	
12	0165639	1	Snap switch cpl. Sprengschalter kpl.	Interruptor de retención compl. Interrupteur extérieur compl.		
21	0168372	1	Adapter Adapter	Adaptador Raccord	3/4 x 5/8in	
22	0168700	1	Nipple fitting Stutzen	Niple Raccord	3/4 x 3in	
24	0168247	1	Boiler Boiler	Caldera Chaudière		
25	0167706	4	Bolt Bolzen	Perno Boulon	3/8-16 x 3in	
26	0167735	4	Lock washer Federring	Federring Rondelle de ressort	3/8in	
27	0167730	8	Flat washer Scheibe	Arandela elástica Rondelle de ressort	3/8in	
28	0169413	1	Pipe Rohr	Tubo Conduit	1-1/2in	
29	0168705	1	Nipple fitting Stutzen	Niple Raccord	1.5 x 4.5	
30	0166711	1	Thermowell Thermoschutzrohr	Termopozo Sonde thermométrique	1/4 x 2-1/2 NPT	
31	0166712	1	Thermocouple Thermoement	Termopar Thermocouple		
32	0168328	1	Elbow Krümmer	Codo Coude	1in NPT	
33	0168704	1	Nipple fitting Stutzen	Niple Raccord	1 x 11in	
34	0168324	1	Bushing Buchse	Buje Douille	1-1/2 x 1in	
37	0167704	6	Bolt Bolzen	Perno Boulon	1/4-20 x 3/4in	
38	0168277	2	Pump Pumpe	Bomba Pompe	265gph	

Heater cpl.
 Heizung, kpl.
 Calentador, acopl.
 Réchauffeur compl.

HSH 700G

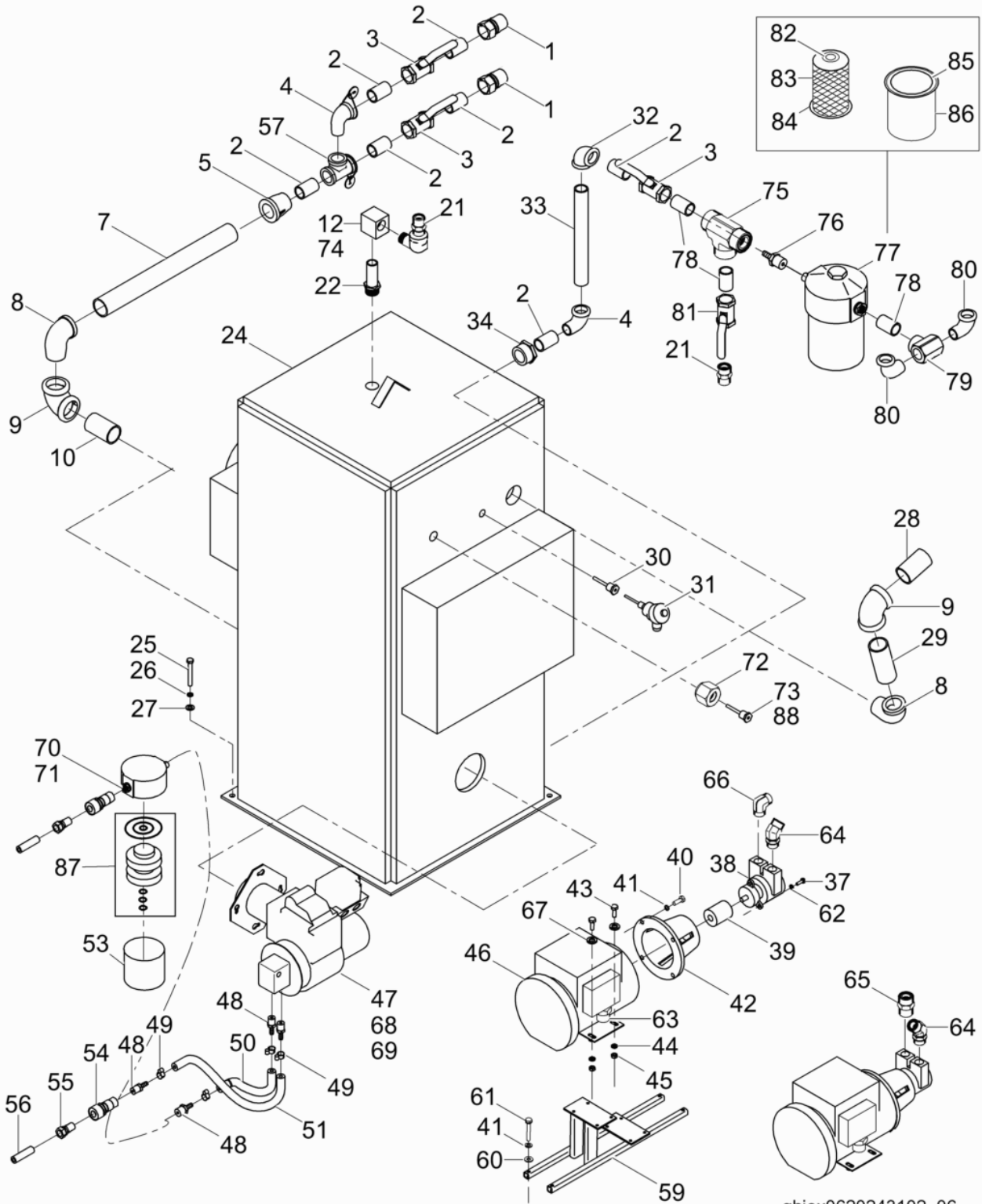

ghiex0620243102_06

Ref. Pos.	Part No. Artikel Nr.	Qty. St.	Description Beschreibung	Descripción Description	Measurem./Abm.	Norm
					Torque/Drehm.	Sealant Schmierstoff
39	0168111	2	Coupling Kupplung	Acoplamiento Accouplement		
40	0167705	8	Bolt Bolzen	Perno Boulon	3/8-16 x 1in	
41	0167735	8	Lock washer Federring	Federring Rondelle de ressort	3/8in	
42	0168110	2	Adapter Adapter	Adaptador Raccord		
43	0167708	8	Bolt Bolzen	Perno Boulon	5/16-18 x 1in	
44	0167736	8	Washer-lock Federring	Arandela elástica Rondelle de ressort	5/16in	
45	0167692	8	Nut Mutter	Tuerca Écrou	5/16in - 18	
46	0168756	2	Motor Motor	Motor Moteur	1/2hp	
47	0168077	1	Burner Brenner	Quemador Brûleur	50Hz	
48	0168284	4	Hose barb Schlauchwiderhaken	Púa de manguera Barbelure de flexible	1/4 x 1/4in	
49	0168334	4	Clamp Schelle	Abrazadera Agrafe		
50	0174002	1	Fuel Hose Kit Kraftstoffleitungssatz	Juego de manguera de combustible. Jeu de tuyau à essence		
51	0170018	1	Fuel return hose Kraftstoffrückleitung	Manguera de combustible de retorno Tuyau à essence de retour		
52	0168044	1	Hose barb Schlauchwiderhaken	Púa de manguera Barbelure de flexible	1/4 x 3/8in	
53	0168078	1	Filter housing Filtergehäuse	Carcasa filtro Filtre		
54	0168294	2	Quick coupler Druckventil	Válvula de presión Soupape de compression		
55	0168295	2	Coupling Kupplung	Acoplamiento Accouplement		
56	0168489	2	Nipple fitting Stutzen	Niple Raccord	1/4 NPT x 2in	
57	0168326	1	Tee-fitting T-Verschraubung	Unión forma T Raccord T	1in NPT	
59	0169779	1	Dual pump mount Doppel-Pumpenkonsole	Montura de bomba doble Support de montage de pompe jumelée		
60	0167729	14	Flat washer Scheibe	Arandela elástica Rondelle de ressort	1/4in	
61	0167703	4	Bolt Bolzen	Perno Boulon	1/4-20 x 1-3/4in	
62	0167733	6	Lock washer Federring	Federring Rondelle de ressort	1/4in	
63	0166458	2	Cord grip Zugentlastung	Alivio de esfuerzos Effort à la décharge	1/2in	
64	0168409	2	Adapter Adapter	Adaptador Raccord		

Heater cpl.
 Heizung, kpl.
 Calentador, acopl.
 Réchauffeur compl.

HSH 700G

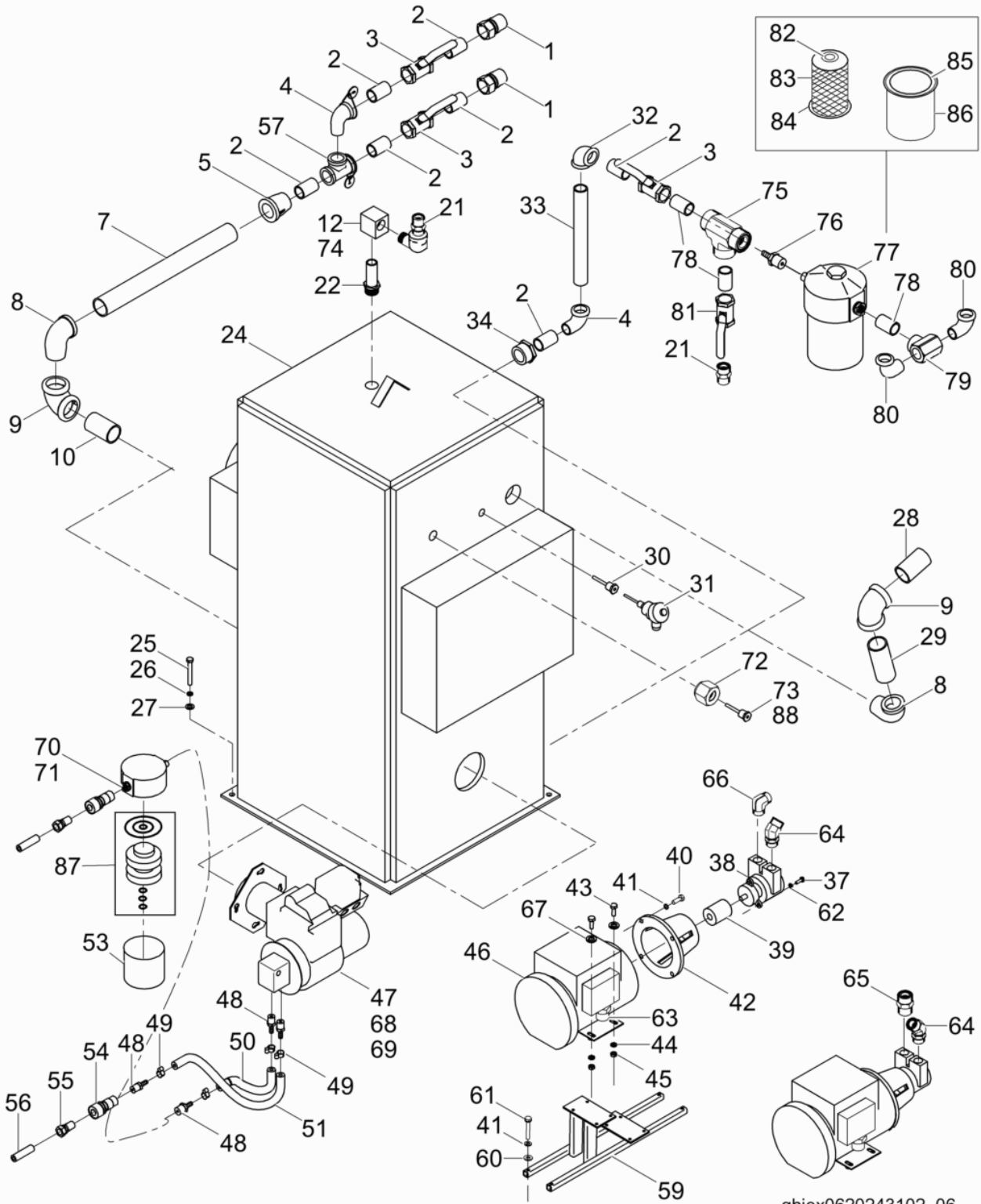

ghiex0620243102_06

Ref. Pos.	Part No. Artikel Nr.	Qty. St.	Description Beschreibung	Descripción Description	Measurem./Abm.	Norm
					Torque/Drehm.	Sealant Schmierstoff
65	0168373	1	Adapter Adapter	Adaptador Raccord	1/2 x 3/4in	
66	0168374	1	Adapter Adapter	Adaptador Raccord		
67	0167731	8	Washer-flat Unterlegscheibe	Arandela plana Rondelle	5/16in	
68	0168774	2	Adapter Adapter	Adaptador Raccord	3/8 x 1/4in	
69	0168773	2	Spacer plates Abstandsplatten	Placas espaciadoras Plaquettes entretoises	25mm	
70	0168034	1	Bushing Buchse	Buje Douille	3/8 x 1/4in	
71	0168062	1	Nipple fitting Stutzen	Niple Raccord	1/4in NPT	
72	0168036	1	Bushing Buchse	Buje Douille	3/4 x 3/8in	
73	0166811	1	Electrode Elektrode	Electrodo Électrode		
74	0165980	1	Cable cpl. Kabel kpl.	Cable compl. Câble compl.		
75	0168406	1	Tee-fitting T-Verschraubung	Unión forma T Raccord T	1 x 1 x 3/4in	
76	0168011	1	Bushing Buchse	Buje Douille	1 x 3/4in	
77	0168297	1	Strainer Sieb	Tamizador Tamis		
78	0168390	3	Nipple fitting Stutzen	Niple Raccord	3/4 x 1-1/2in	
79	0168056	1	Tee-fitting T-Verschraubung	Unión forma T Raccord T	3/4in NPT	
80	0168029	2	Elbow Krümmer	Codo Coude	3/4in NPT	
81	0168256	1	Valve Ventil	Válvula Soupape		
82	0169093	1	Gasket Dichtung	Junta Joint		
83	0169050	1	Filter Filter	Filtro Filtre		
84	0169094	1	Gasket Dichtung	Junta Joint		
85	0169092	1	Gasket Dichtung	Junta Joint		
86	0168297	1	Strainer Sieb	Tamizador Tamis		
87	0168966	1	Filter Element Set Filterelement Satz	Elemento del Filtro Juego Élément du Filtre Jue		
88	0166812	1	Probe Luftklappensonde	Sonda-conjunto del cañón Sonde - ensemble de conduit		

Hydronic Heater cpl.
Wärmeübertragende Heizung, kpl.
Calentador hidrónico, acopl.
Réchauffeur caloporteur compl.

HSH 700G

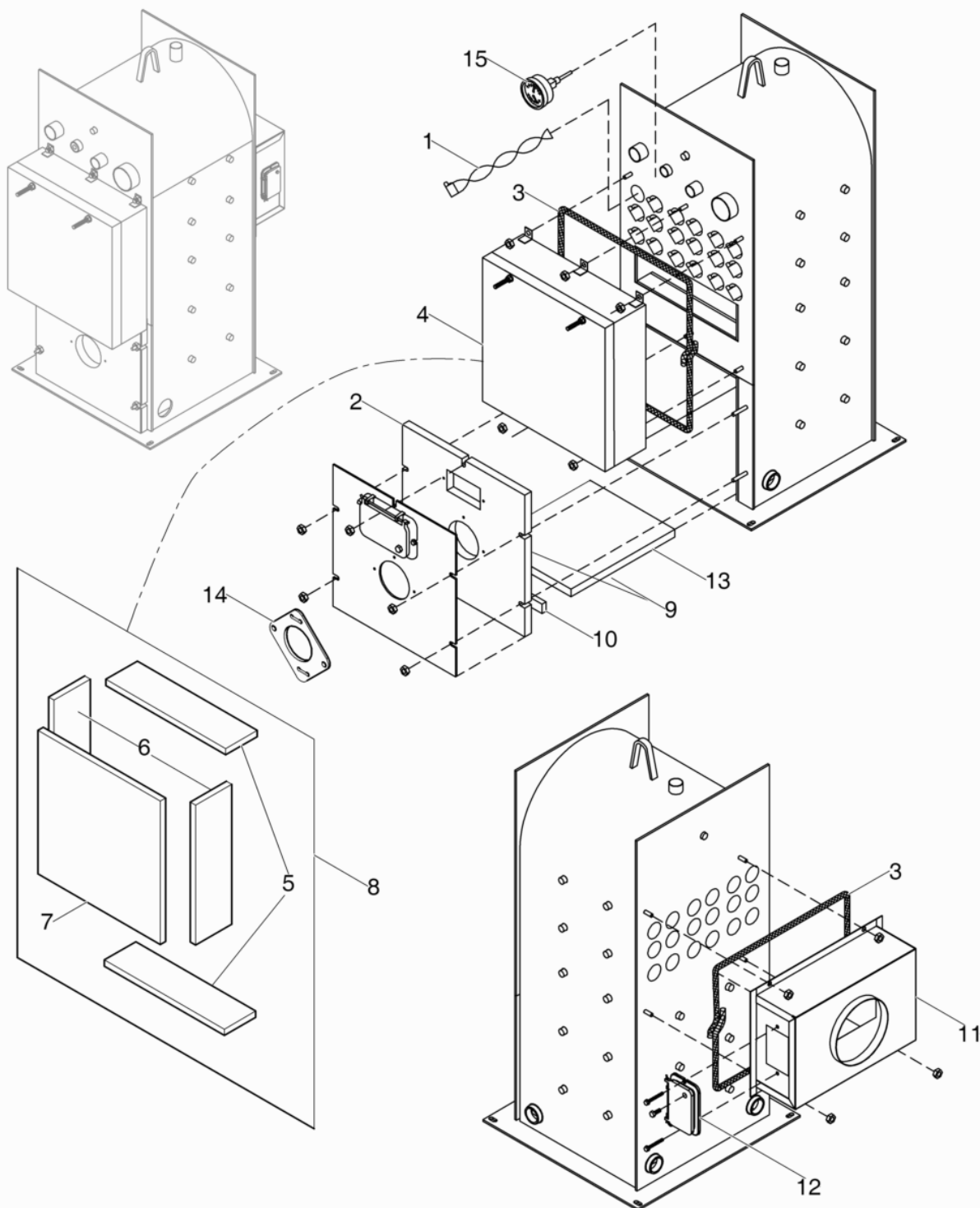

ghiex0168247100_01

Ref. Pos.	Part No. Artikel Nr.	Qty. St.	Description Beschreibung	Descripción Description	Measurem./Abm.	Norm
					Torque/Drehm.	Sealant Schmierstoff
1	0168163	18	Turbulator Turbulator	Turbulator Turboventilateur	19.25 x 1.5	
2	0169029	1	Insulation Isoliermaterial	Aislación Matière isolante		
3	0169159	1	Gasket Dichtung	Junta Joint		
4	0177481	1	Flue box assembly Rauchgas-Box kpl.	Cuadro de combustión compl. Boîte de fumée compl.		
5	0169006	1	Insulation Isoliermaterial	Aislación Matière isolante		
6	0174729	1	Panel Panel	Panel Tableau		
7	0174726	1	Flue box door Rauchabzugskastentür	Puerta de la caja del cañón Porte de cheminée		
8	0177480	1	Insulation Kit Isoliermaterialsatz	Juego de aislación Jeu de matière isolante		
9	0177479	1	Insulation Kit Isoliermaterialsatz	Juego de aislación Jeu de matière isolante		
10	0177478	1	Insulation Isoliermaterial	Aislación Matière isolante		
11	0177477	1	Box Kasten	Caja Boîte		
12	0177476	1	Door Tür	Puerta Porte		
13	0177743	1	Insulation Isoliermaterial	Aislación Matière isolante		
14	0168976	1	Gasket Dichtung	Junta Joint		
15	0168975	1	Gauge Anzeiger	Indicador Indicateur		

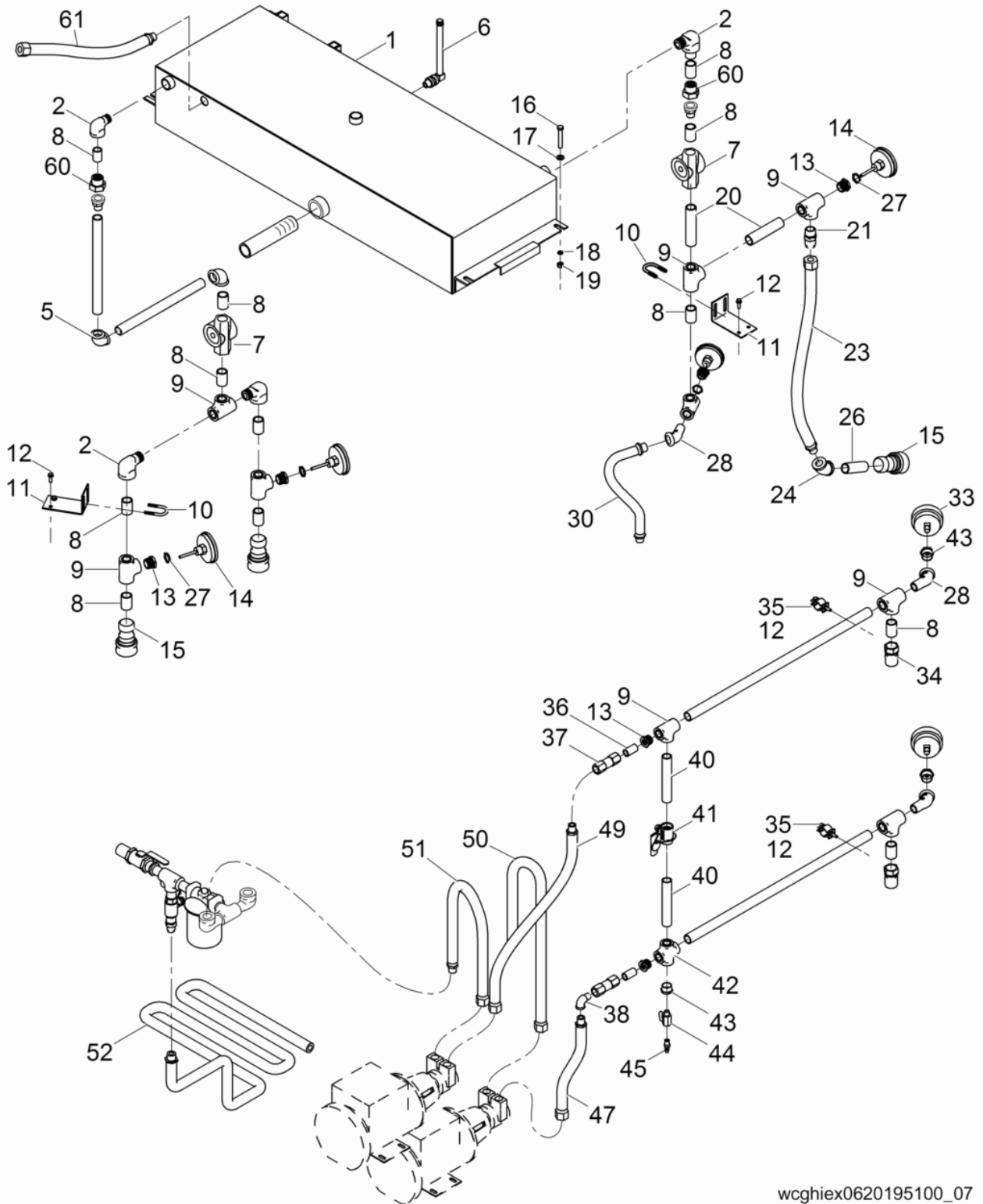

wcghiex0620195100_07

Ref. Pos.	Part No. Artikel Nr.	Qty. St.	Description Beschreibung	Descripción Description	Measurem./Abm.	Norm
					Torque/Drehm.	Sealant Schmierstoff
1	0169582	1	Expansion tank Expansionstank, kpl.	Tanque de expansión, acopl. Réservoir d'expansion compl.		
2	0168029	4	Elbow Krümmer	Codo Coude	3/4in NPT	
5	0168027	2	Elbow Krümmer	Codo Coude	3/4in NPT	
6	0168805	1	Sight gauge Sichtanzeiger	Mirilla Niveau à vue	3/8 NPT x 7	
7	0168091	2	Flow indicator Flussanzeiger	Indicador de flujo Débitmètre	3/4in NPT	
8	0168390	10	Nipple fitting Stutzen	Niple Raccord	3/4 x 1-1/2in	
9	0168056	10	Tee-fitting T-Verschraubung	Unión forma T Raccord T	3/4in NPT	
10	0167841	2	U-Bolt U-Bolzen	Perno forma U Boulon U	1/4-20 x 2 x 1-1/8	
11	0166905	2	Bracket Konsole	Soporte Support		
12	0167793	10	Screw Schraube	Tornillo Vis	1/4-14 x 3/4in	
13	0168060	6	Bushing Buchse	Buje Douille	3/4 x 1/2in	
14	0168096	4	Thermometer Thermometer	Termómetro Thermomètre	1/2 NPT	
15	0168213	3	Quick connect Schnellkupplung	Conexión rápida Branchement rapide	3/4 NPT	
16	0167706	4	Bolt Bolzen	Perno Boulon	3/8-16 x 3in	
17	0167730	4	Flat washer Scheibe	Arandela elástica Rondelle de ressort	3/8in	
18	0167735	4	Lock washer Federring	Federring Rondelle de ressort	3/8in	
19	0167691	4	Nut Mutter	Tuerca Écrou	3/8in - 16	
20	0168701	2	Nipple fitting Stutzen	Niple Raccord	3/4 x 4-1/2	
21	0168393	1	Adapter Adapter	Adaptador Raccord	3/4 x 3/4in	
23	0166131	1	Hose cpl. Schlauch kpl.	Manguera compl. Tuyau compl.		
24	0168498	1	Elbow Krümmer	Codo Coude	3/4in NPT	
27	0166459	4	Lock nut Sicherungsmutter	Contratuerca Contre-écrou		
28	0168026	3	Elbow Krümmer	Codo Coude	3/4in NPT	
30	0165805	1	Hose cpl. Schlauch kpl.	Manguera compl. Tuyau compl.		
33	0168772	2	Gauge-pressure Druckanzeiger	Indicador-presión Manomètre	0-200psi	

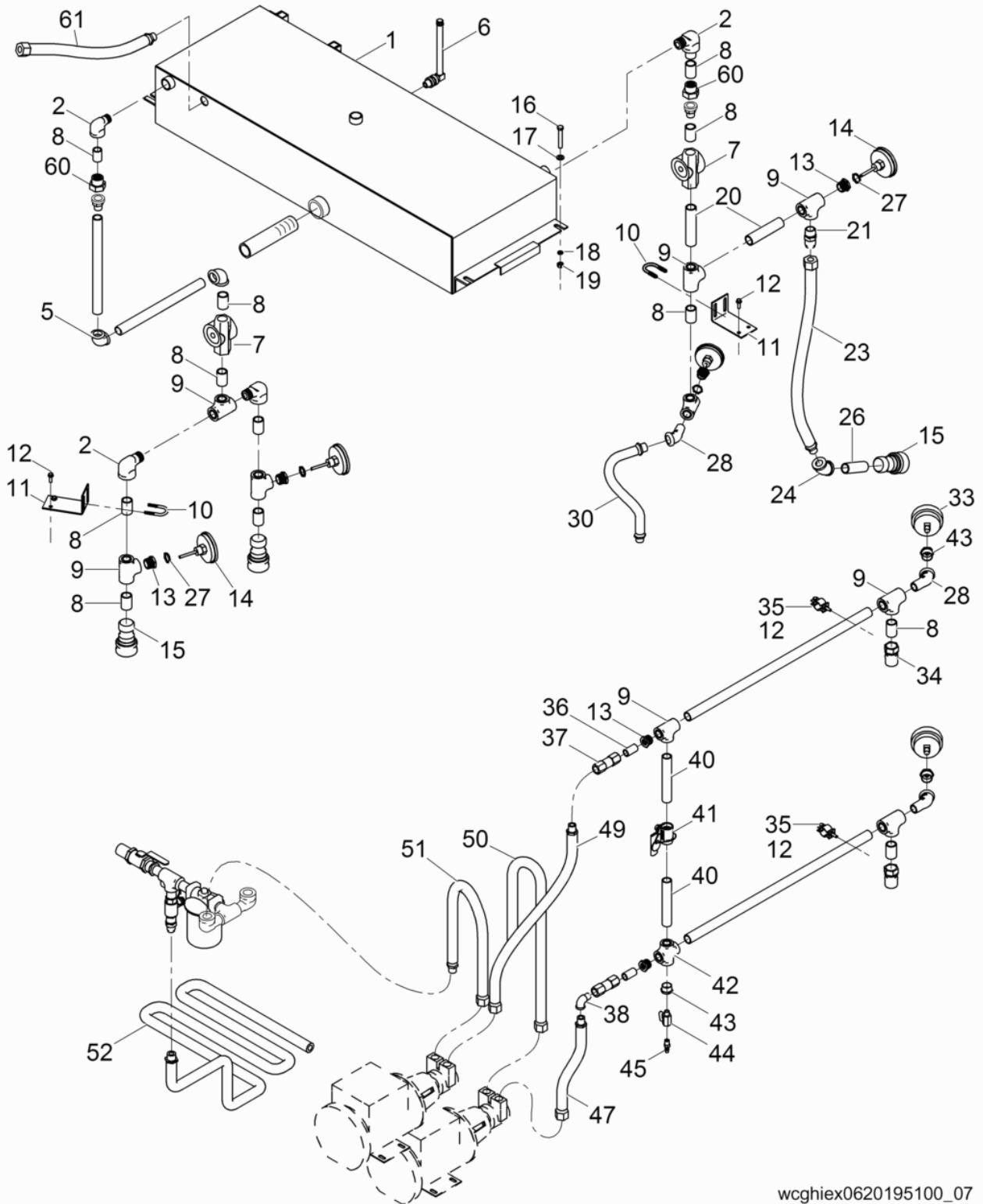

wcghiex0620195100_07

Ref. Pos.	Part No. Artikel Nr.	Qty. St.	Description Beschreibung	Descripción Description	Measurement/Abm.	Norm
					Torque/Drehm.	Sealant Schmierstoff
34	0168214	2	Quick connect Schnellkupplung	Conexión rápida Branchement rapide	3/4in NPT	
35	0168016	4	Conduit hanger Isolierrohrhänger	Colgador de portacables Support de conduit	3/4in	
36	0168353	2	Nipple fitting Stutzen	Niple Raccord	1/2 NPT x 1-1/2in	
37	0168351	2	Valve-check Rückschlagventil	Válvula checadora Clapet de non-retour	1/2 NPT	
38	0168236	2	Elbow Krümmer	Codo Coude	1/2in NPT	
40	0168702	2	Nipple fitting Stutzen	Niple Raccord	3/4 x 6in	
41	0168050	1	Valve Ventil	Válvula Soupape		
42	0168053	1	Cross Kreuz	Cruz Croisillon	3/4in NPT	
43	0168035	3	Bushing Buchse	Buje Douille	3/4 x 1/4in	
44	0168425	1	Valve Ventil	Válvula Soupape		
45	0168218	1	Coupling Kupplung	Acoplamiento Accouplement		
47	0166221	1	Hose cpl. Schlauch kpl.	Manguera compl. Tuyau compl.		
49	0166222	1	Hose cpl. Schlauch kpl.	Manguera compl. Tuyau compl.		
50	0166220	1	Hose cpl. Schlauch kpl.	Manguera compl. Tuyau compl.		
51	0166219	1	Hose cpl. Schlauch kpl.	Manguera compl. Tuyau compl.		
52	0165632	1	Fill hose cpl. Füllschlauch	Manguera de llenado Tuyau de remplissage		
60	0168058	2	Union Verbindung	Unión Raccord droit	3/4in NPT	
61	0165978	1	Hose cpl. Schlauch kpl.	Manguera compl. Tuyau compl.	5/8 ID x 23in	

Pump and motor cpl.
Pumpe und Motor, kpl.
Bomba y motor, acopl.
Pompe et moteur compl.

HSH 700G

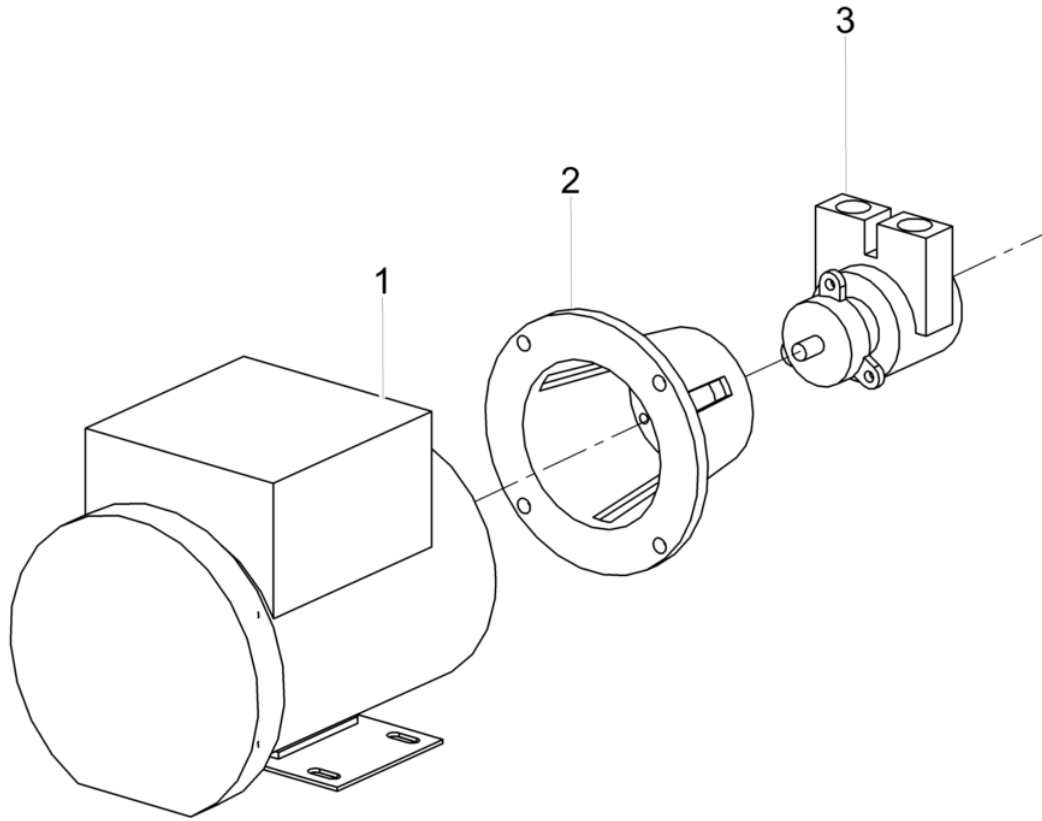

ghiex0166236100_01

Ref. Pos.	Part No. Artikel Nr.	Qty. St.	Description Beschreibung	Descripción Description	Measurem./Abm.	Norm
					Torque/Drehm.	Sealant Schmierstoff
1	0168756	1	Motor Motor	Motor Moteur	1/2hp	
2	0168111	1	Coupling Kupplung	Acoplamiento Accouplement		
3	0168277	1	Pump Pumpe	Bomba Pompe	265gph	

Hose Reel cpl.
Schlauchhaspel, kpl.

HSH 700G

Carrete de la manguera compl.
Dévidoir enrouleur compl.

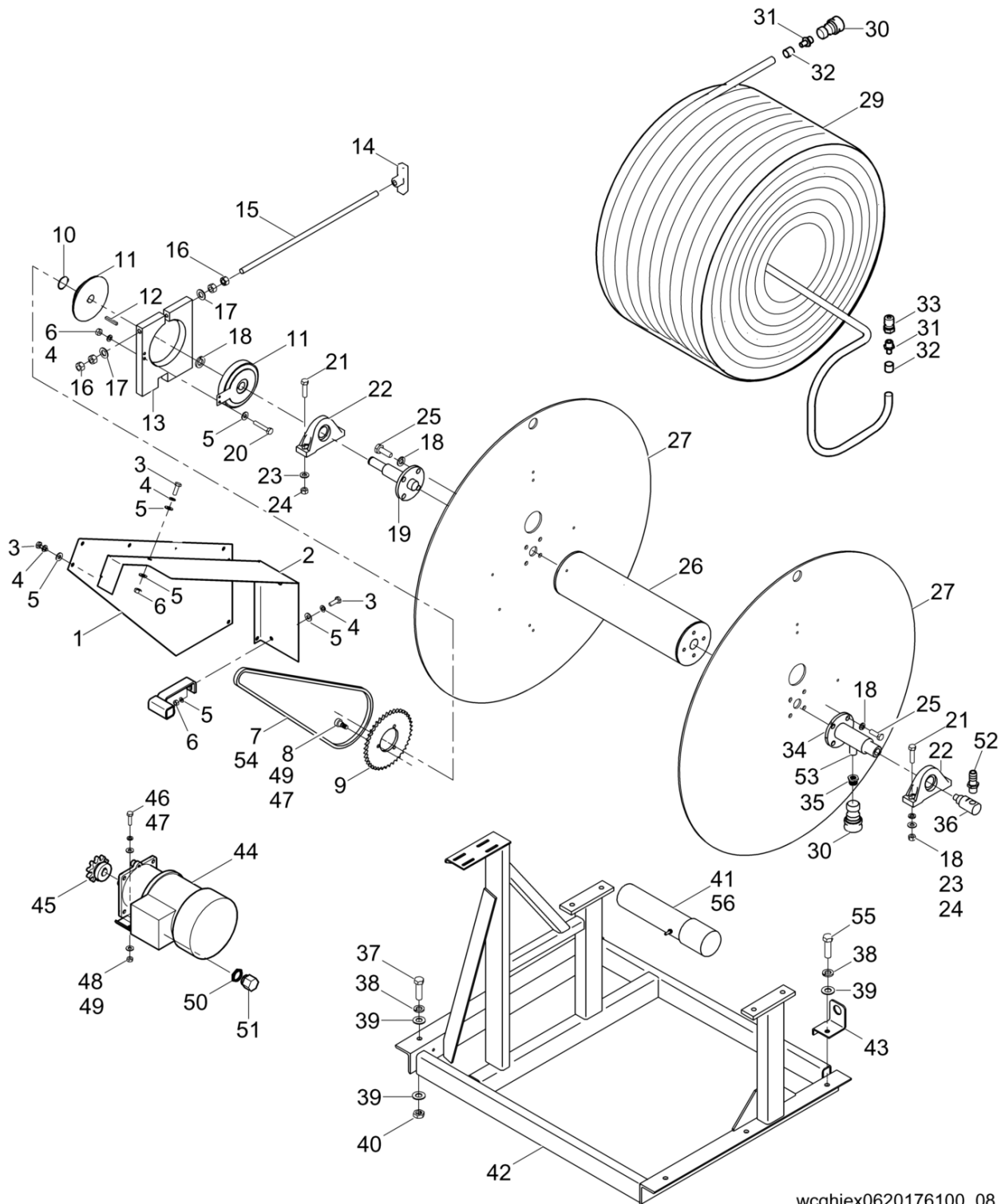

wcghiex0620176100_08

Ref. Pos.	Part No. Artikel Nr.	Qty. St.	Description Beschreibung	Descripción Description	Measurem./Abm.	Norm
					Torque/Drehm.	Sealant Schmierstoff
1	0167121	1	Chain guard cover Kettenschutzabdeckung	Cubierta, protección de la cadena Plaque de carter de chaîne		
2	0167120	1	Chain guard Kettenschutz	Protección de la cadena Carter de chaîne		
3	0167704	9	Bolt Bolzen	Perno Boulon	1/4-20 x 3/4in	
4	0167733	11	Lock washer Federring	Federring Rondelle de ressort	1/4in	
5	0167729	13	Flat washer Scheibe	Arandela elástica Rondelle de ressort	1/4in	
6	0167690	4	Nut Mutter	Tuerca Écrou	1/4in - 20	
7	0168075	1	Chain Kette	Cadena Chaîne		
8	0167840	3	Screw Schraube	Tornillo Vis	3/8 x 1/4	
9	0166894	1	Sprocket Kettenrad	Rueda de cadena Pignon à chaîne		
10	0168106	1	Retaining ring Sicherungsring	Anillo de retención Bague d'arrêt	1 x 0.94	
11	0168104	1	Clutch Kupplung	Embrague Embrayage		
12	0168292	1	Square key Passfeder	Chaveta Clavette	1/4 x 1/4 x 1-7/8in	
13	0166902	1	Brake Bremse	Freno Frein		
14	0168100	1	Knob Griff	Empuñadura Poignée		
15	0169385	1	Rod Stange	Varilla Tringle	3/8-16 x 6ft	
16	0167691	6	Nut Mutter	Tuerca Écrou	3/8in - 16	
17	0167730	2	Flat washer Scheibe	Arandela elástica Rondelle de ressort	3/8in	
18	0167734	12	Lock washer Federring	Federring Rondelle de ressort	1/2in	
19	0169459	1	Spindle Spindel	Husillo Broche		
20	0167702	2	Bolt Bolzen	Perno Boulon	1/4-20 x 1-1/2in	
21	0167701	4	Bolt Bolzen	Perno Boulon	1/2-3 x 2in	
22	0168103	2	Bearing Lager	Rodamiento Roulement		
23	0167728	4	Flat washer Scheibe	Arandela elástica Rondelle de ressort	1/2in	
24	0167689	4	Nut Mutter	Tuerca Écrou	1/2in - 13	
25	0167699	8	Bolt Bolzen	Perno Boulon	1/2-13 x 1-1/2in	

Hose Reel cpl.
Schlauchhaspel, kpl.

HSH 700G

Carrete de la manguera compl.
Dévidoir enrouleur compl.

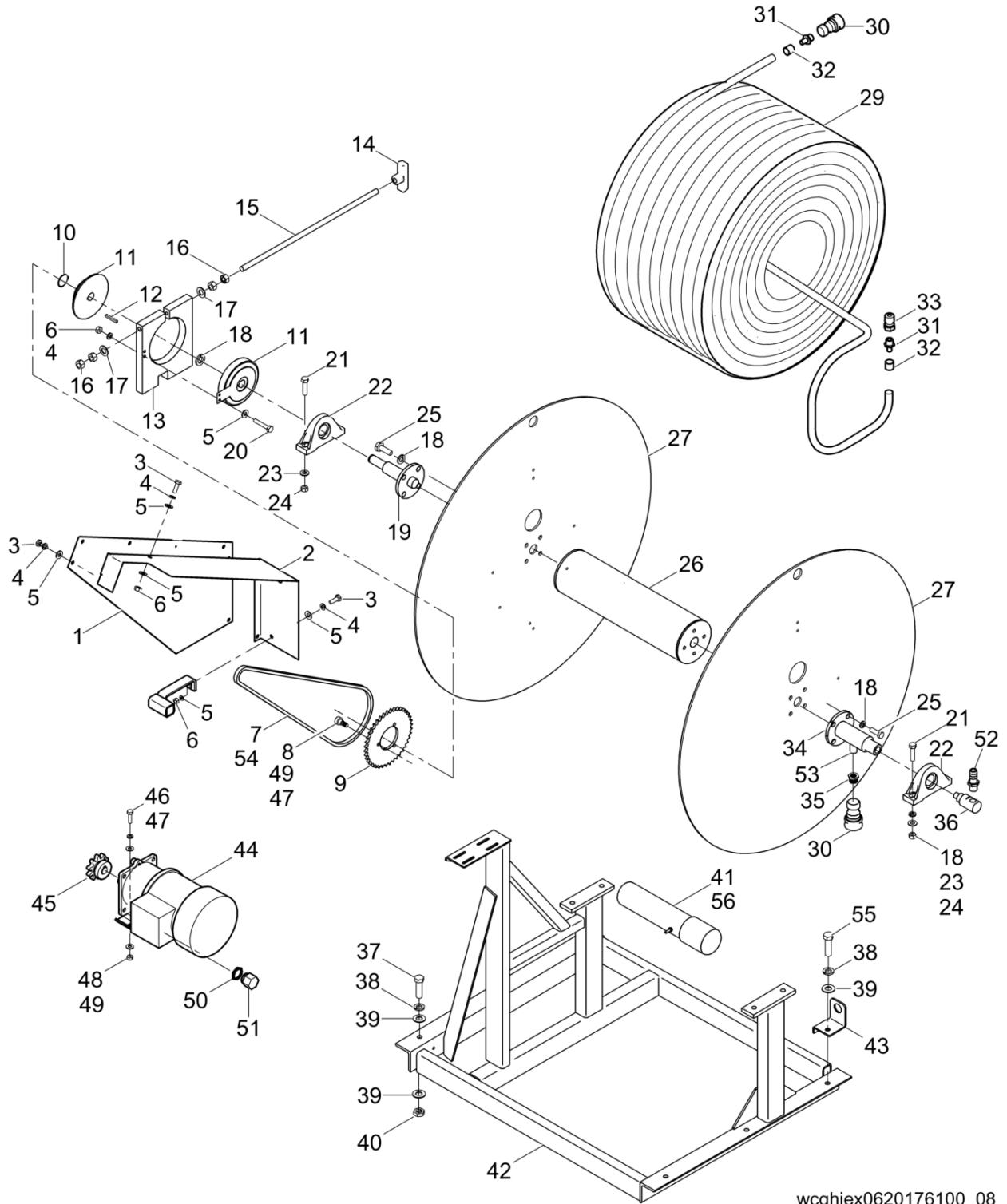

wcghiex0620176100_08

Ref. Pos.	Part No. Artikel Nr.	Qty. St.	Description Beschreibung	Descripción Description	Measurem./Abm.	Norm
					Torque/Drehm.	Sealant Schmierstoff
26	0169880	1	Spool cpl. Spule, kpl.	Bobina, acopl. Bobine compl.		
27	0167629	2	Spool disc Spulenscheibe	Disco de la bobina Disque à bobine	1/4 x 42in	
29	0169435	1	Hose Schlauch	Manguera Tuyau	200psi	
30	0168213	2	Quick connect Schnellkupplung	Conexión rápida Branchement rapide	3/4 NPT	
31	0168437	2	Hose barb Schlauchwiderhaken	Púa de manguera Barbelure de flexible	5/8 x 3/4in	
32	0168042	2	Hose ferrule Schlauchzwinge	Férula de manguera Bague de flexible	0.975in ID	
33	0168214	2	Quick connect Schnellkupplung	Conexión rápida Branchement rapide	3/4in NPT	
34	0169683	1	Spindle Spindel	Husillo Broche		
35	0168060	1	Bushing Buchse	Buje Douille	3/4 x 1/2in	
36	0168109	1	Swivel Drehung	Unión giratoria Pivot	1/2 x 1/2	
37	0167716	5	Bolt Bolzen	Perno Boulon	1/2-13 x 1in	
38	0167734	5	Lock washer Federring	Federring Rondelle de ressort	1/2in	
39	0167728	12	Flat washer Scheibe	Arandela elástica Rondelle de ressort	1/2in	
40	0167689	6	Nut Mutter	Tuerca Écrou	1/2in - 13	
41	0168721	1	Manual holder Handbuchhalter	Soporte manual Support de manuel		
42	0169563	1	Frame Rahmen	Chasis Châssis		
43	0169689	1	Bracket Konsole	Soporte Support		
44	0168755	1	Gear Zahnrad	Engranaje Engrenage		
45	0168107	1	Sprocket Kettenrad	Rueda de cadena Pignon à chaîne		
46	0167721	4	Bolt Bolzen	Perno Boulon	1/4-20 x 1in	
47	0167733	4	Lock washer Federring	Federring Rondelle de ressort	1/4in	
48	0167729	8	Flat washer Scheibe	Arandela elástica Rondelle de ressort	1/4in	
49	0167690	4	Nut Mutter	Tuerca Écrou	1/4in - 20	
50	0166459	1	Lock nut Sicherungsmutter	Contratuerca Contre-écrou		
51	0166458	1	Cord grip Zugentlastung	Alivio de esfuerzos Effort à la décharge	1/2in	

Hose Reel cpl.
Schlauchhaspel, kpl.

HSH 700G

Carrete de la manguera compl.
Dévidoir enrouleur compl.

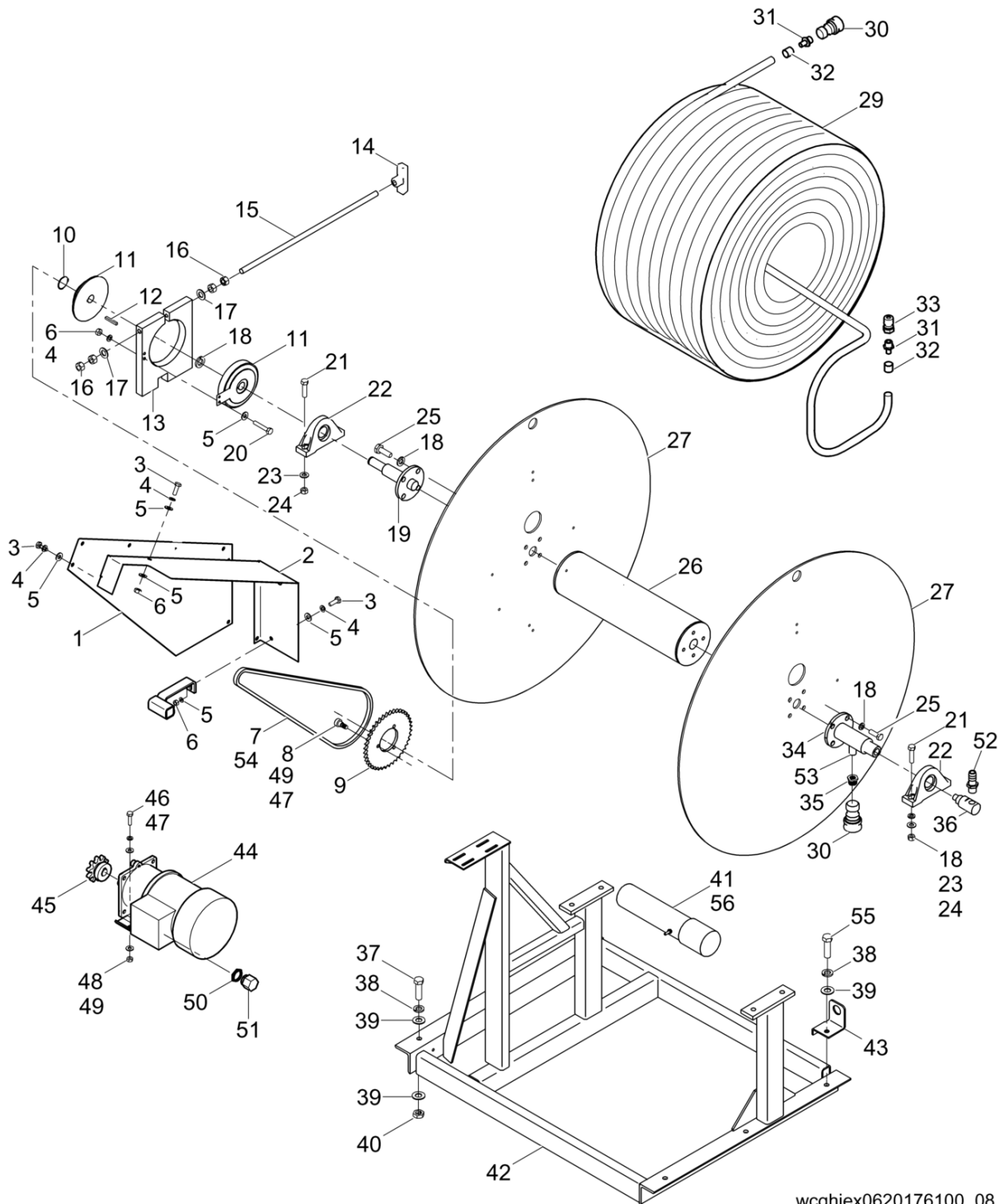

wcghiex0620176100_08

Ref. Pos.	Part No. Artikel Nr.	Qty. St.	Description Beschreibung	Descripción Description	Measurement./Abm.	Norm
					Torque/Drehm.	Sealant Schmierstoff
52	0168371	1	Adapter Adapter	Adaptador Raccord	1/2 x 5/8in	
53	0168353	1	Nipple fitting Stutzen	Niple Raccord	1/2 NPT x 1-1/2in	
54	0168076	1	Chain Kette	Cadena Chaîne		
55	0167699	1	Bolt Bolzen	Perno Boulon	1/2-13 x 1-1/2in	
56	0167793	3	Screw Schraube	Tornillo Vis	1/4-14 x 3/4in	

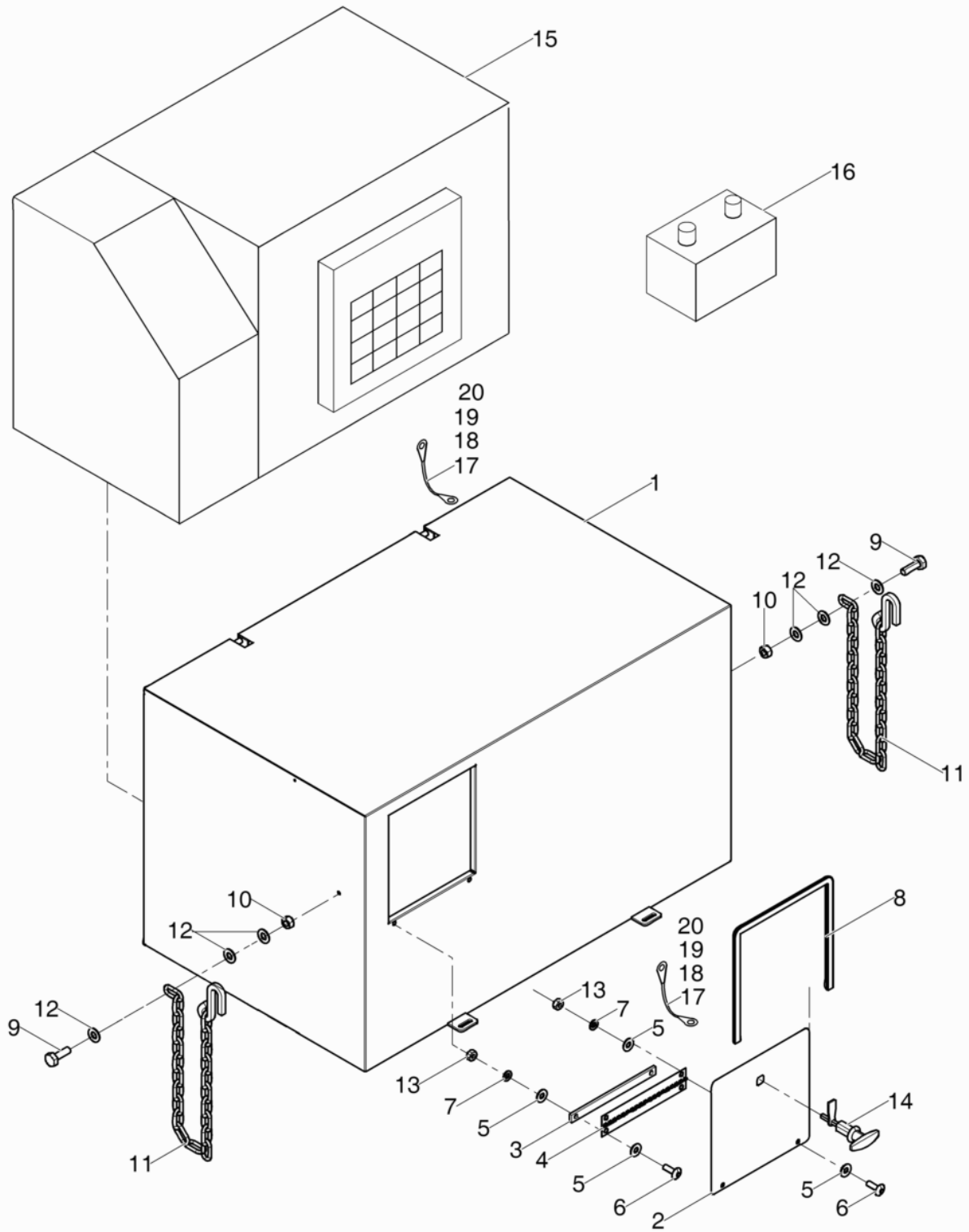

ghiex0620243202_09

Ref. Pos.	Part No. Artikel Nr.	Qty. St.	Description Beschreibung	Descripción Description	Measurement/Abm.	Norm
					Torque/Drehm.	Sealant Schmierstoff
1	0174006	1	Cover Deckel	Tapa Couvercle		
2	0174005	1	Door Tür	Puerta Porte		
3	0166950	1	Spacer Abstandsstück	Espaciador Entretoise		
4	0166948	1	Hinge Scharnier	Bisagra Charnière		
5	0167729	8	Flat washer Scheibe	Arandela elástica Rondelle de ressort	1/4in	
6	0167857	4	Screw Schraube	Tornillo Vis	1/4-20 x 3/4	
7	0167733	4	Lock washer Federring	Federring Rondelle de ressort	1/4in	
8	0168354	3	Trim Einfassung	Protección Garniture	12ft	
9	0167708	2	Bolt Bolzen	Perno Boulon	5/16-18 x 1in	
10	0167694	2	Nut Mutter	Tuerca Écrou	5/16-18	
11	0168312	2	Safety chain set Sicherheitskettensatz	Juego de cadenas de seguridad Jeu de chaîne de sûreté	3/16 x 48	
12	0167731	6	Washer-flat Unterlegscheibe	Arandela plana Rondelle	5/16in	
13	0167690	4	Nut Mutter	Tuerca Écrou	1/4in - 20	
14	0174008	1	Handle Handgriff	Manija Poignée		
15	0176370	1	Generator Generator	Generador Générateur		
16	0165552	1	Battery Batterie	Batería Batterie	12V	
17	0177336	2	Ground wire Erdungsdraht	Alambre a tierra Fil de masse		
18	0167819	3	Screw Schraube	Tornillo Vis	10-32 x 3/4	
19	0181623	3	Washer Scheibe	Arandela Rondelle	No.10	
20	0181624	3	Nut Mutter	Tuerca Écrou	No.10	

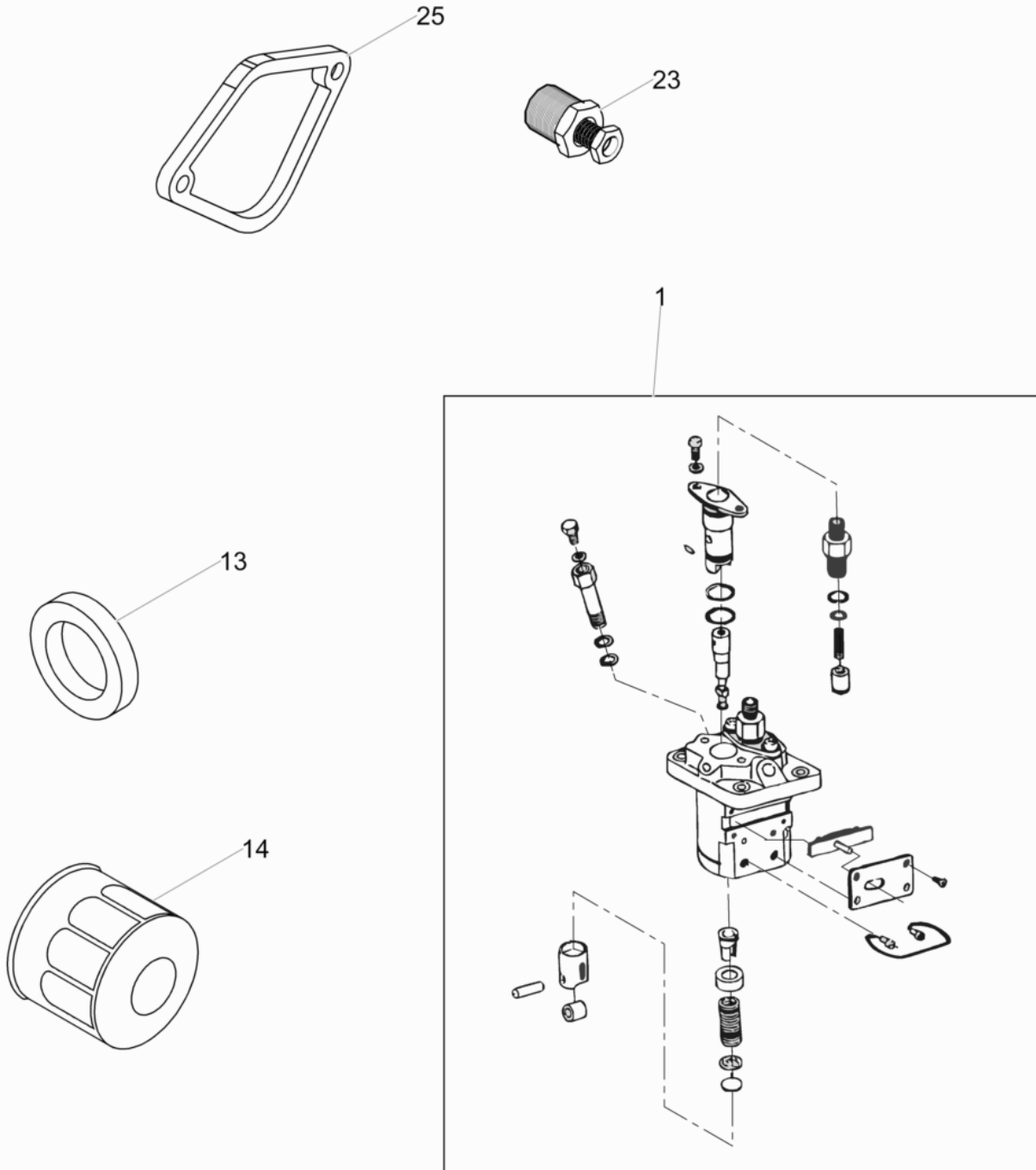

ghiex0168754100_01

Ref. Pos.	Part No. Artikel Nr.	Qty. St.	Description Beschreibung	Descripción Description	Measuram./Abm.	Norm
					Torque/Drehm.	Sealant Schmierstoff
1	0169157	1	Filter-fuel Kraftstofffilter	Filtro de combustible Filtre à carburant		
2	0169158	1	Oil filter Ölfilter	Filtro de aceite Filtre d'huile		
3	0169156	1	Air filter Luftfilter	Filtro del aire Filtre à air		
4	0169167	1	Starter Starter	Arrancador Démarreur		
5	0169162	1	Cap-coolant fill Kappe	Tapa Capuchon		
6	0169172	1	Switch Schalter	Interruptor Interrupteur		

Control Panel cpl.
 Betätigung kpl.
 Regulador compl.
 Commande compl.

HSH 700G

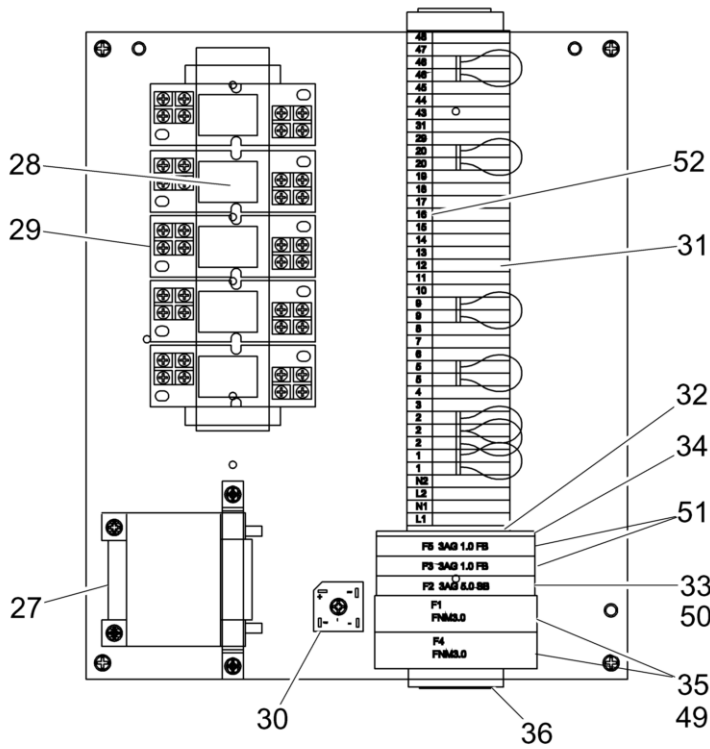
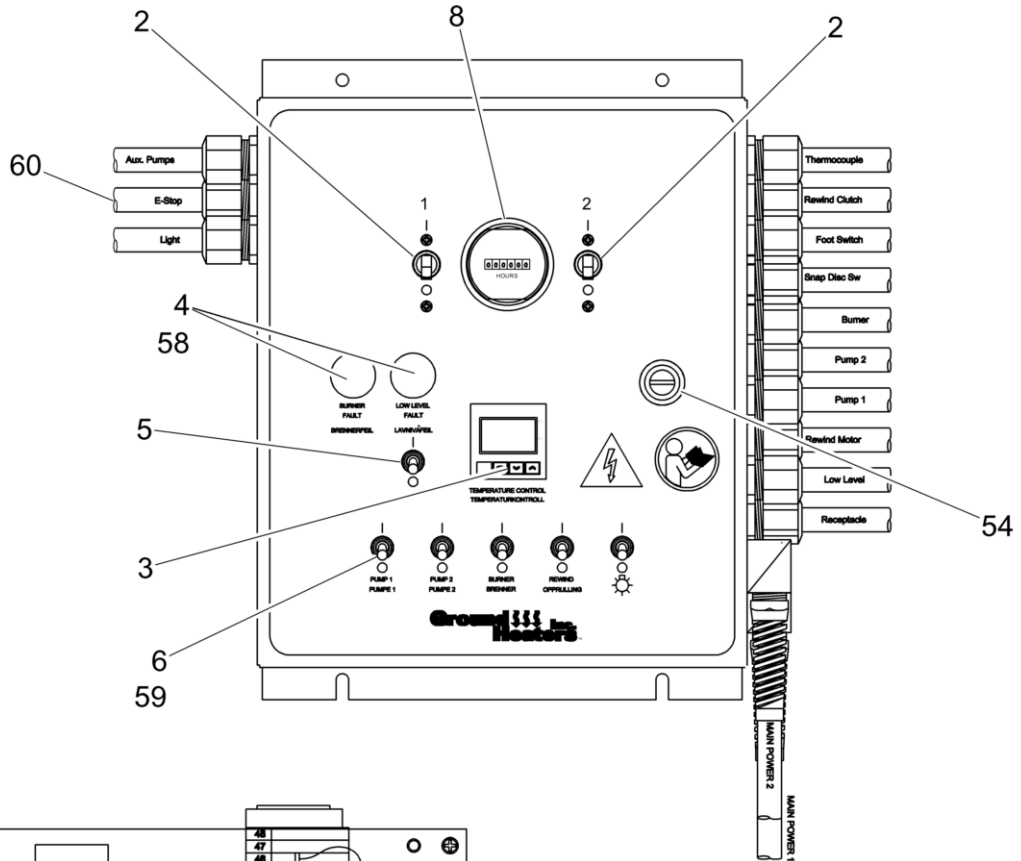

wcghiex0620195100_10

Ref. Pos.	Part No. Artikel Nr.	Qty. St.	Description Beschreibung	Descripción Description	Measur./Abm.	Norm
					Torque/Drehm.	Sealant Schmierstoff
2	0172036	2	Breaker Unterbrecher	Interruptor Disjoncteur		
3	0170275	1	Temperature control Temperaturregelung	Control de temperatura Commande de température		
4	0172037	2	Light-pilot Pilotlicht	Luz piloto Lampe - pilote	220V	
5	0172038	1	Toggle switch Kipphebelschalter	Interruptor de volquete Interrupteur de bascule		
6	0172039	3	Toggle switch Kipphebelschalter	Interruptor de volquete Interrupteur de bascule		
8	0172040	1	Meter-hour Stundenzähler	Medidor-hora Compteur horaire	220V	
27	0166560	1	Transformer Transformator	Transformador Transformateur	120/12.6V	
28	0172041	5	Socket Socket	Tomacorriente Douille		
29	0172042	5	Socket Socket	Tomacorriente Douille		
30	0166564	1	Rectifier Gleichrichter	Rectificador Rectificateur	25A	
31	0166696	39	Terminal block Anschlussblock	Bloque terminal Borne serre-fils	0.25	
32	0171313	1	Terminal-end plate Anschlussklemme	Terminal de conexión Cosse terminale		
33	0172043	3	Fuse Sicherung	Fusible Fusible	300V	
34	0177097	1	End plate fuse Endplattensicherung	Placa extrema fusible Plaque d'extrémité fusible		
35	0166625	2	Fuse block Sicherungsblock	Bloque de fusibles Bloc-fusible		
36	0170668	4	Terminal block end Anschlussblockende	Extremo Fin de bloc terminal		
49	0166709	2	Fuse Sicherung	Fusible Fusible	13/32 x 1.5	
50	0166693	1	Fuse Sicherung	Fusible Fusible	5A	
51	0166814	2	Fuse Sicherung	Fusible Fusible	1A	
52	0171314	39	Terminal-marker Anschlussklemme	Terminal de conexión Cosse terminale		
54	0168001	1	Latch Verriegelung	Aldaba Loquet		
58	0172047	2	Light-bulb Glühbirne	Bombilla Ampoule	220V	
59	0172048	6	Toggle switch Kipphebelschalter	Interruptor de volquete Interrupteur de bascule		
60	0183799	1	Cable Kabel	Cable Câble		

Burner cpl.
Brenner, kpl.
Quemador, acopl.
Brûleur compl.

HSH 700G

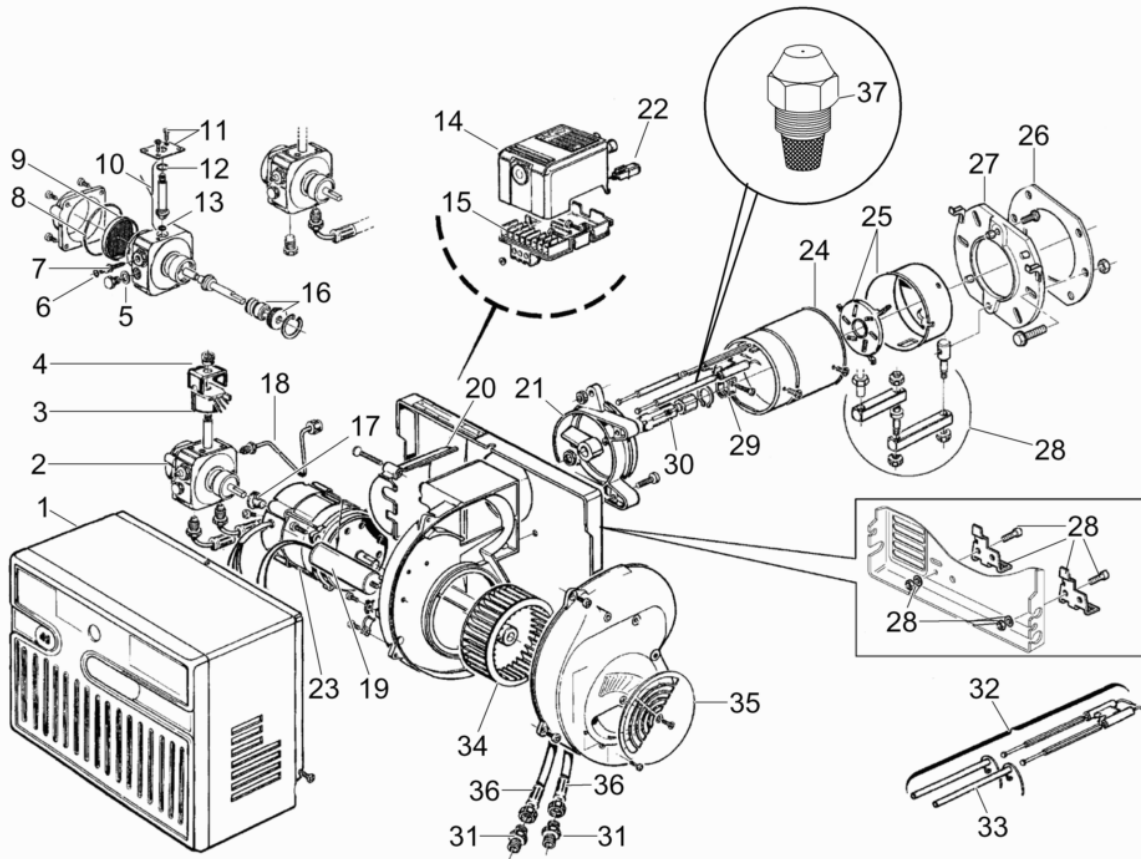

ghiex0168077100_01

Ref. Pos.	Part No. Artikel Nr.	Qty. St.	Description Beschreibung	Descripción Description	Measurem./Abm.	Norm
					Torque/Drehm.	Sealant Schmierstoff
1	0175144	1	Burner cover Brennerabdeckung	Tapa del quemador Couver-brûleur		
2	0175145	1	Fuel Pump Kraftstoffpumpe	Bomba de Combustible Pompe à Carburant		
3	0172665	1	Coil Spule	Bobina Bobine		
4	0172664	1	Bracket Konsole	Soporte Support		
5	0172656	1	Washer Scheibe	Arandela Rondelle		
6	0172657	1	O-Ring O-Ring	Anillo-O Joint torique		
7	0172676	1	Regulator Regulator	Regulador Régulateur		
8	0172658	1	O-Ring O-Ring	Anillo-O Joint torique		
9	0172659	1	Screen Sieb	Tamiz Tamis		
10	0172660	1	Valve Ventil	Válvula Soupape		
11	0172669	1	Plate Platte	Placa Plaque		
12	0172661	1	O-Ring O-Ring	Anillo-O Joint torique		
13	0172662	1	O-Ring O-Ring	Anillo-O Joint torique		
14	0175146	1	Control Box cpl. Kontrollkasten kpl.	Caja de Control compl. Boîtier de Commande compl.	530SE	
15	0169288	1	Primary control sub-base Sub-Konsole, Hauptbetätigung	Subbase, control primario Sous-base, commande principale		
16	0175147	1	Seal-shaft Wellendichtring	Sello del eje Bague d'étanchéité		
17	0169290	1	Drive key Keil	Chaveta Clavette		
18	0175148	1	Fuel line Kraftstoffleitung	Manguera de combustible Conduit de carburant		
19	0175149	1	Capacitor Kondensator	Condensador Condensateur		
20	0175150	1	Cover Deckel	Tapa Couvercle		
21	0175151	1	Collar Manschette	Collar Collet		
22	0169292	1	Photo cell Photozelle	Fotocelda Cellule photoélectrique		
23	0169291	1	Motor Motor	Motor Moteur	220V	
24	0175152	1	Blast tube Brennerrohr	Estalle tubo Estalle tubo		
25	0175153	1	Ring and diffuser disc Flammkopf+stauscheibe	Llame y disco de difusor Embout gueulard + af		

Burner cpl.
Brenner, kpl.
Quemador, acopl.
Brûleur compl.

HSH 700G

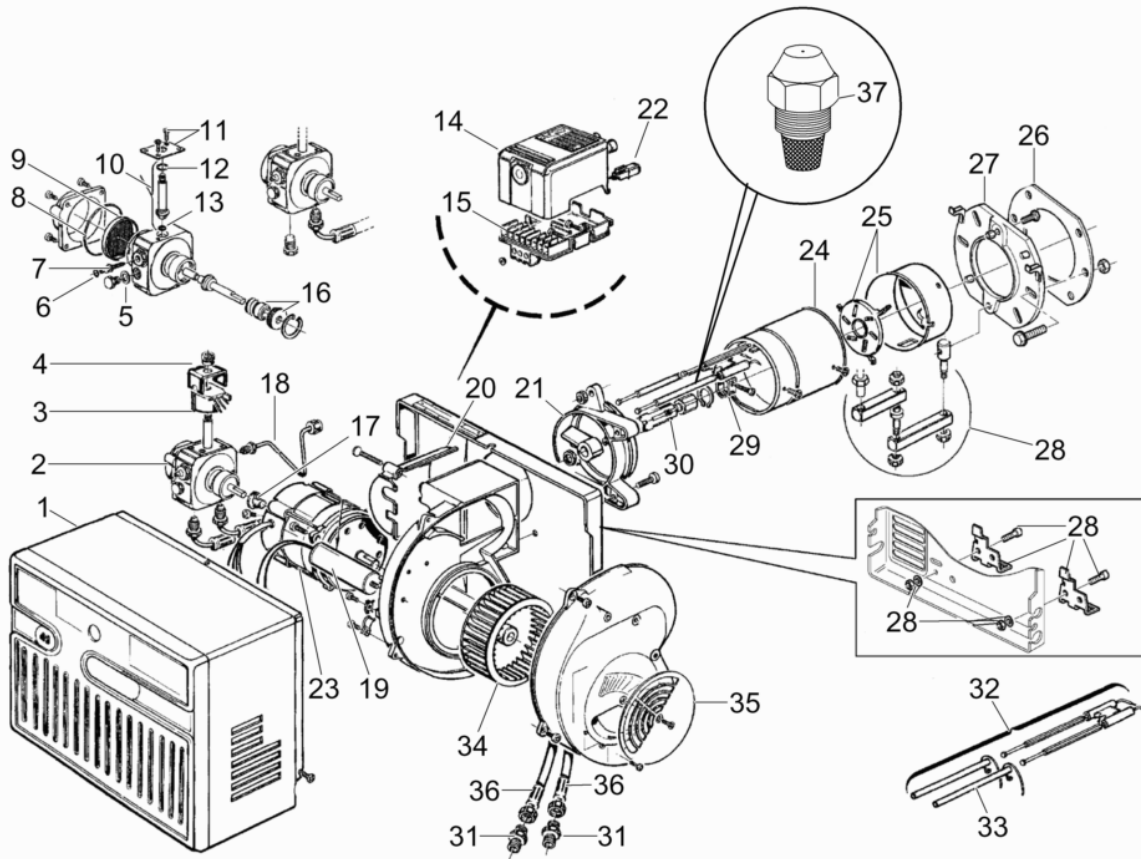

ghiex0168077100_01

Ref. Pos.	Part No. Artikel Nr.	Qty. St.	Description Beschreibung	Descripción Description	Measurement./Abm.	Norm
					Torque/Drehm.	Sealant Schmierstoff
26	0175154	1	Gasket Dichtung	Junta Joint		
27	0175155	1	Flange Flansch	Brida Collerette		
28	0175157	1	Hinge cpl. Scharnier	Bisagra Charnière		
29	0175159	1	Bracket Konsole	Soporte Support		
30	0175160	1	Nozzle retainer Düsenhalter	Retenedor de tobera de inyección Support de gicleur		
31	0175161	1	Connector Anschlußteil	Conector Connecteur		
32	0175162	1	Electrode cpl. Elektrode	Electrodo Électrode		
33	0175163	1	Insulator Isoliermaterial	Aislación Matière isolante		
34	0172650	1	Fan Gebläserad	Ventilador Ventilateur		
35	0172679	1	Cover Deckel	Tapa Couvercle		
36	0175164	1	Flexible tube Schlauch	Manguera Tuyau flexible		
37	0169209	1	Nozzle Düse	Tobera Ajutage		

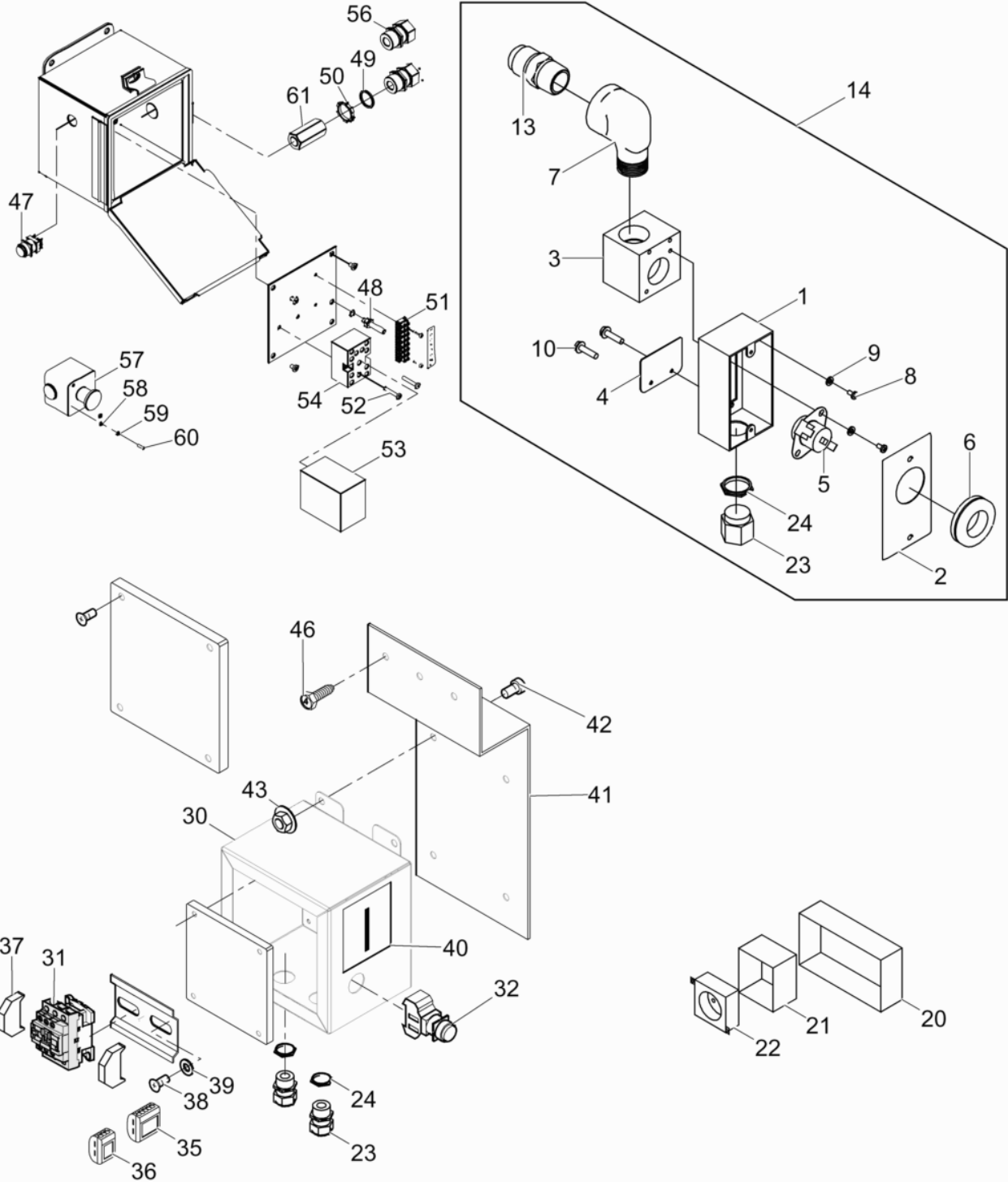

ghiex0620243107_11

Ref. Pos.	Part No. Artikel Nr.	Qty. St.	Description Beschreibung	Descripción Description	Measurem./Abm.	Norm
					Torque/Drehm.	Sealant Schmierstoff
1	0166931	1	Enclosure Gehäuse	Cubierta Enceinte		
2	0166930	1	Cover plate Deckplatte	Placa de cubierta Couvercle de protection	4 x 2-1/8in	
3	0166926	1	Snap disc block Schnapp-Scheibenblock	Bloque de discos de retención Bloc de disque d'arrêt		
4	0166927	1	Cover plate Deckplatte	Placa de cubierta Couvercle de protection		
5	0166613	1	Limit control Grenztafter	Interruptor limitador Interrupteur-limiteur		
6	0168477	1	Grommet Tülle	Ojal Passe-fil	1-3/8 x 1in ID	
7	0168029	1	Elbow Krümmer	Codo Coude	3/4in NPT	
8	0167835	4	Screw Schraube	Tornillo Vis	6-32 x 1/4in	
9	0167838	4	Washer Scheibe	Arandela Rondelle	No. 6	
10	0167883	2	Screw Schraube	Tornillo Vis	No. 10 x 3/4	
13	0168372	1	Adapter Adapter	Adaptador Raccord	3/4 x 5/8in	
14	0165639	1	Snap switch cpl. Sprengschalter kpl.	Interruptor de retención compl. Interrupteur extérieur compl.		
20	0166788	1	Electrical box Schaltkasten	Caja eléctrica Coffret électrique		
21	0166789	2	Cover Deckel	Tapa Couvercle		
22	0166790	2	Receptacle (socket) Steckdose	Tomacorriente Prise de courant		
23	0166458	1	Cord grip Zugentlastung	Alivio de esfuerzos Effort à la décharge	1/2in	
24	0166459	1	Lock nut Sicherungsmutter	Contratuerca Contre-écrou		
30	0173160	1	Enclosure Gehäuse	Cubierta Enceinte		
31	0173163	1	Relay Relais	Relai Relais	25A	
32	0173164	1	Momentary switch Momentschalter	Interruptor momentáneo Interrupteur sans maintien		
33	0166458	3	Cord grip Zugentlastung	Alivio de esfuerzos Effort à la décharge	1/2in	
34	0166459	3	Lock nut Sicherungsmutter	Contratuerca Contre-écrou		
35	0166813	2	Terminal Anschlußklemme	Terminal de conexión Borne d'attache	12-28 GA	
36	0166833	4	Terminal Anschlußklemme	Terminal de conexión Borne d'attache	12-28 GA	
37	0170668	2	Terminal block end Anschlussblockende	Extremo Fin de bloc teminal		

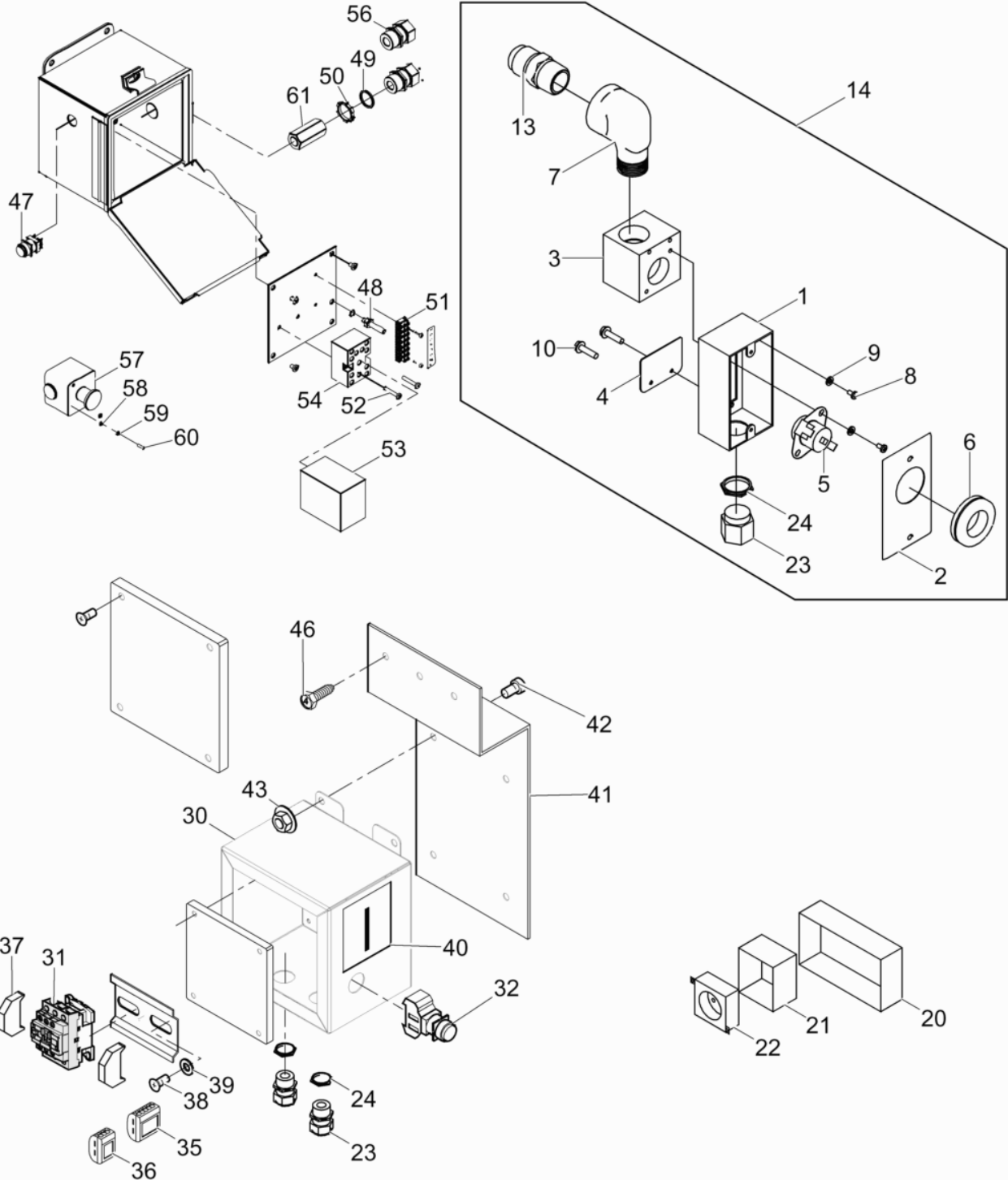

ghiex0620243107_11

Ref. Pos.	Part No. Artikel Nr.	Qty. St.	Description Beschreibung	Descripción Description	Measurement./Abm.	Norm
					Torque/Drehm.	Sealant Schmierstoff
38	0167897	2	Screw Schraube	Tornillo Vis	8-32 x 3/8	
39	0167921	2	Washer-lock Federring	Arandela elástica Rondelle de ressort	No. 8	
40	0173166	1	Label Aufkleber	Calcomania Autocollant		
41	0173144	1	Bracket Konsole	Soporte Support		
42	0173162	4	Bolt Bolzen	Perno Boulon	1/4-20 x 1in	
43	0167690	4	Nut Mutter	Tuerca Écrou	1/4in - 20	
46	0167793	3	Screw Schraube	Tornillo Vis	1/4-14 x 3/4in	
47	0166808	1	Switch Schalter	Interruptor Interrupteur		
48	0167690	1	Nut Mutter	Tuerca Écrou	1/4in - 20	
49	0166810	1	Seal ring Dichtungsring	Anillo sellador Rondelle à étancher	1/2in NPT	
50	0166459	2	Lock nut Sicherungsmutter	Contratuerca Contre-écrou		
51	0166807	1	Terminal strip Klemmenleiste	Regleta de bornes Barrette de raccordement		
52	0167821	2	Screw Schraube	Tornillo Vis	No. 8-32 x 1	
53	0166805	1	Module Modul	Módulo Module		
54	0166806	1	Relay base Relais	Relai Relais		
56	0166458	1	Cord grip Zugentlastung	Alivio de esfuerzos Effort à la décharge	1/2in	
57	0172078	1	Emergency stop switch Not-Aus Schalter	Interruptor de parada de emergencia Interrupteur d'arrêt d'urgence		
58	0167850	1	Nut Mutter	Tuerca Écrou	6-32	
59	0167838	2	Washer Scheibe	Arandela Rondelle	No. 6	
60	0167836	2	Screw Schraube	Tornillo Vis	6-32x 1/2	
61	0176467	1	Filter Filter	Filtro Filtre		

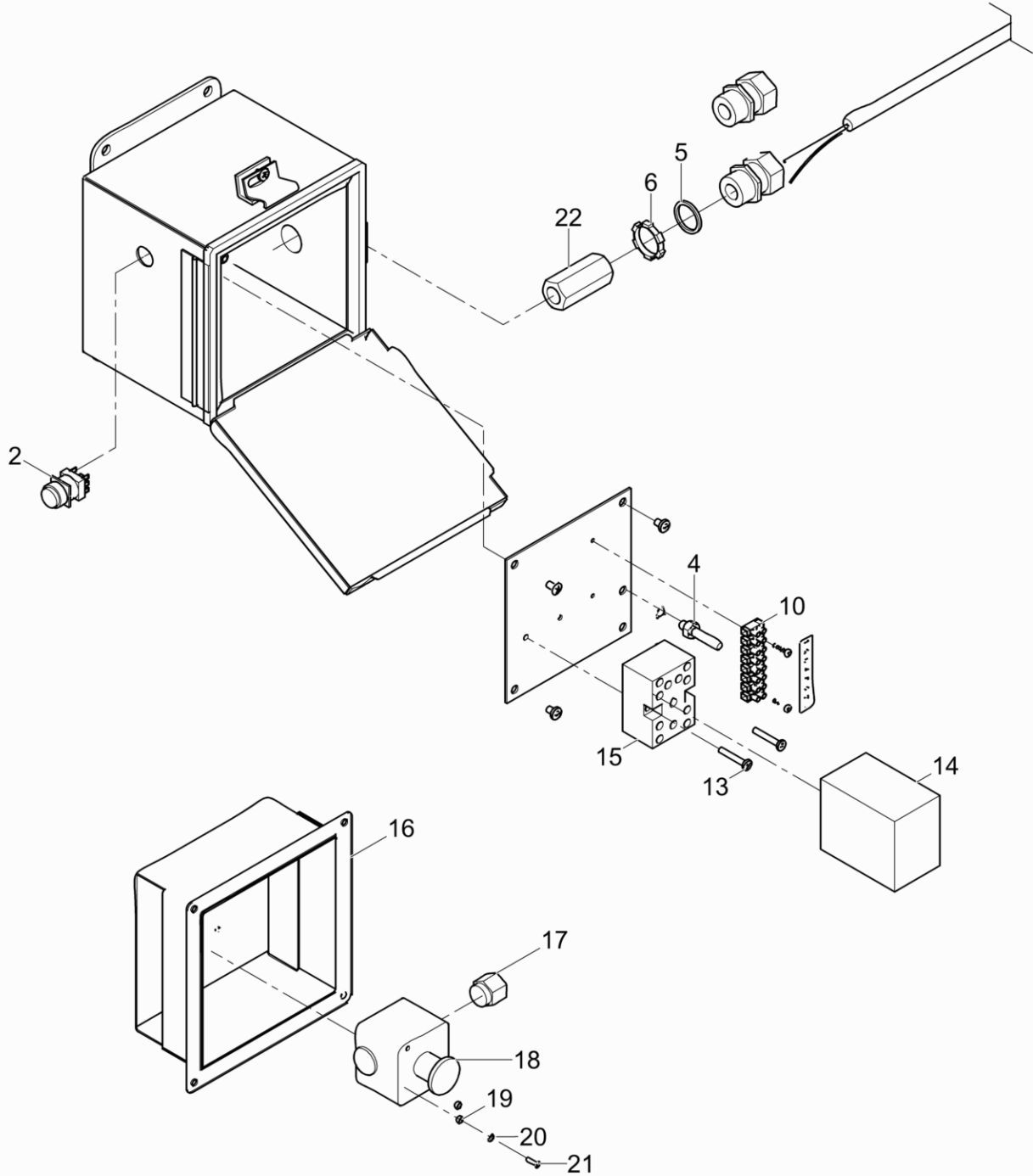

ghiex0620249004_11

Ref. Pos.	Part No. Artikel Nr.	Qty. St.	Description Beschreibung	Descripción Description	Measurement./Abm.	Norm
					Torque/Drehm.	Sealant Schmierstoff
2	0166808	1	Switch Schalter	Interruptor Interrupteur		
4	0167690	1	Nut Mutter	Tuerca Écrou	1/4in - 20	
5	0166810	1	Seal ring Dichtungsring	Anillo sellador Rondelle à étancher	1/2in NPT	
6	0166459	2	Lock nut Sicherungsmutter	Contratuerca Contre-écrou		
10	0166807	1	Terminal strip Klemmenleiste	Regleta de bornes Barrette de raccordement		
13	0167821	2	Screw Schraube	Tornillo Vis	No. 8-32 x 1	
14	0166805	1	Module Modul	Módulo Module		
15	0166806	1	Relay base Relais	Relai Relais		
16	0173141	1	Bracket Konsole	Soporte Support		
17	0166458	1	Cord grip Zugentlastung	Alivio de esfuerzos Effort à la décharge	1/2in	
18	0172078	1	Emergency stop switch Not-Aus Schalter	Interruptor de parada de emergencia Interrupteur d'arrêt d'urgence		
19	0167850	2	Nut Mutter	Tuerca Écrou	6-32	
20	0167838	2	Washer Scheibe	Arandela Rondelle	No. 6	
21	0167836	2	Screw Schraube	Tornillo Vis	6-32x 1/2	
22	0176467	1	Filter Filter	Filtro Filtre		

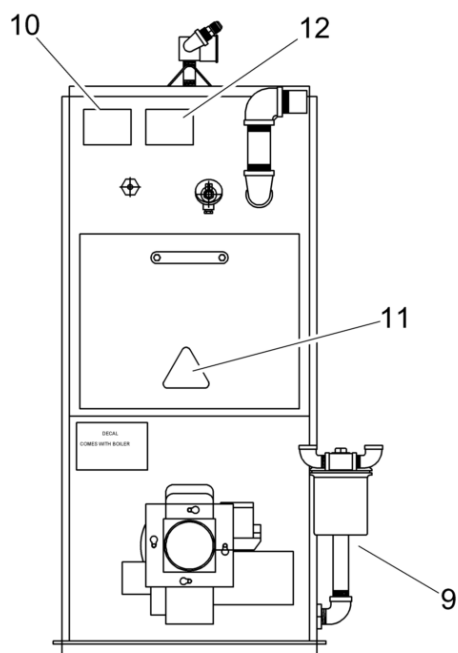
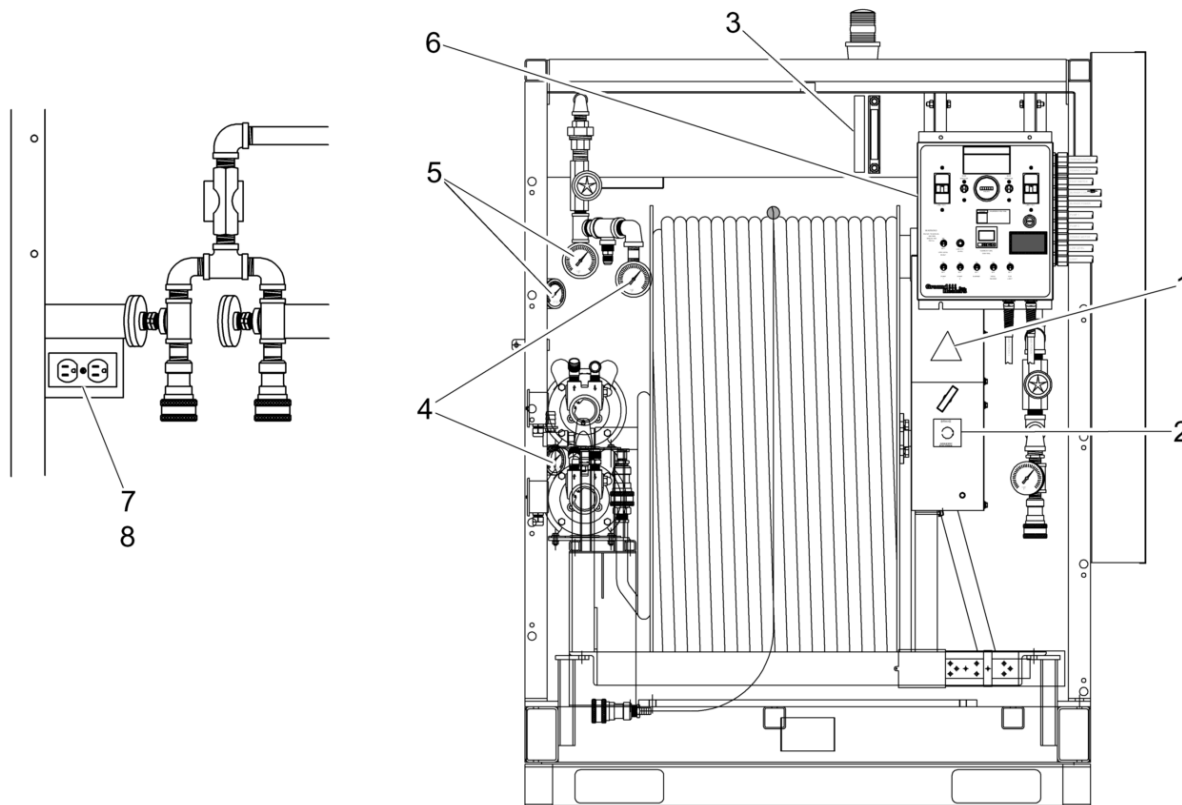

wcghiex0620195100_13

Ref. Pos.	Part No. Artikel Nr.	Qty. St.	Description Beschreibung	Descripción Description	Measurement/Abm.	Norm
					Torque/Drehm.	Sealant Schmierstoff
1	0168890	1	Label-hand entangled Aufkleber	Calcomania Autocollant		
2	0172223	1	Label-hose reel brake Aufkleber	Calcomania Autocollant		
3	0168377	1	Label-heat transfer fluid level Aufkleber	Calcomania Autocollant		
4	0168664	2	Label-pump temperature gauge Aufkleber	Calcomania Autocollant		
5	0168663	2	Label-pump temperature gauge Aufkleber	Calcomania Autocollant		
6	0168783	1	Label-serial no. Aufkleber- Seriennr.	Calcomanía-nro. de serie Autocollant-numéro de série		
7	0168781	1	Label Aufkleber	Calcomania Autocollant		
8	0168782	1	Label-dual pump pack Aufkleber	Calcomania Autocollant		
11	0168893	1	Label-hot surface Aufkleber-heisse Oberfläche	Calcomania-superficie caliente Autocollant-surface brûlante		

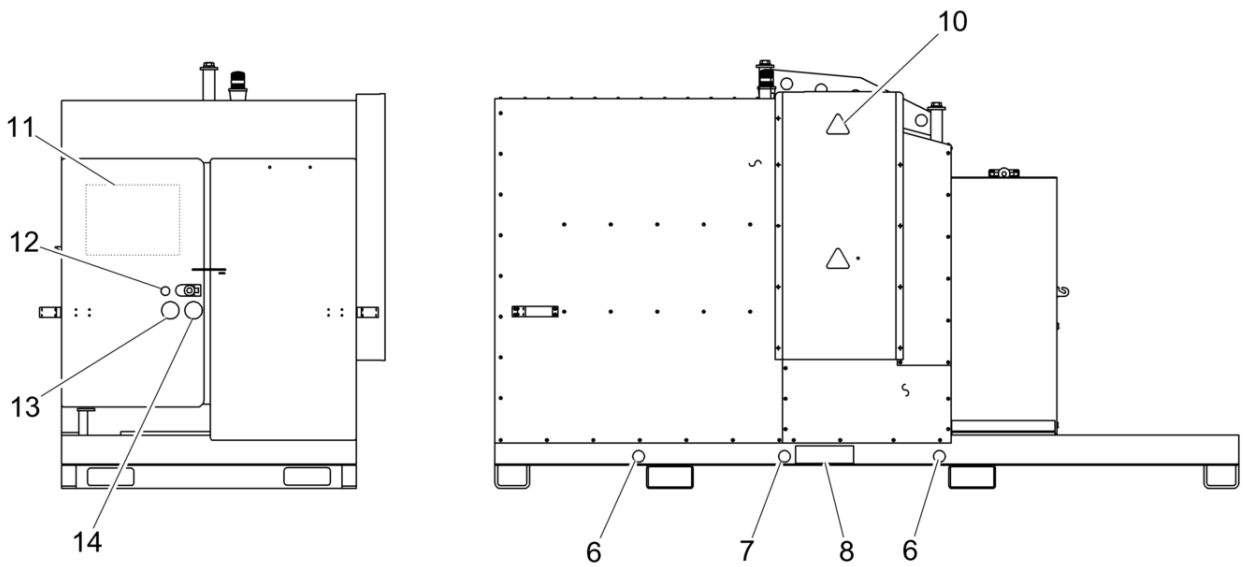
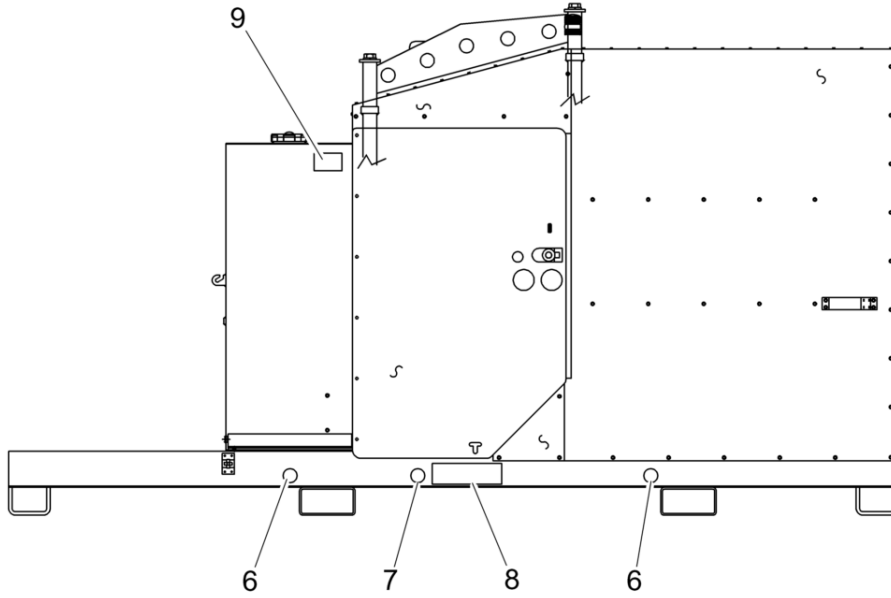

wcghiex0620195100_14

Ref. Pos.	Part No. Artikel Nr.	Qty. St.	Description Beschreibung	Descripción Description	Measurem./Abm.	Norm
					Torque/Drehm.	Sealant Schmierstoff
1	0168890	1	Label-hand entangled Aufkleber	Calcomania Autocollant		
2	0168893	3	Label-hot surface Aufkleber-heisse Oberfläche	Calcomania-superficie caliente Autocollant-surface brûlante		
3	0181146	2	Label-warning Aufkleber-Warnung	Calcomania-Advertencia Autocollant-Avertissement		
4	0181145	1	Label-caution Aufkleber-Vorsicht	Calcomanía-precaución Autocollant-précaution		
5	0181144	2	Label-danger Aufkleber, Gefahr	Calcomanía, peligro Autocollant-danger		
6	0181148	2	Label-lift point Aufkleber	Calcomania Autocollant		
7	0168891	2	Label-safety gloves Aufkleber, Sicherheitshandschuhe	Calcomanía-guantes de seguridad Autocollant-gants de sécurité		
8	0168892	2	Label-eye protection Aufkleber	Calcomania Autocollant		
9	0168895	2	Label-consult Operator's Manual Aufkleber	Calcomania Autocollant		
10	0172223	1	Label-hose reel brake Aufkleber	Calcomania Autocollant		
12	0172365	1	Label-heat transfer fluid level Aufkleber	Calcomania Autocollant		
13	0172366	2	Label-maximum weight Aufkleber	Calcomania Autocollant		
14	0168783	1	Label-serial no. Aufkleber- Seriennr.	Calcomanía-nro. de serie Autocollant-numéro de série		
17	0173202	4	Label-tie down Aufkleber- Verzurrung	Calcomanía-amarre Autocollant-arrimage		
18	0181218	1	Label-operation Aufkleber-Betrieb	Calcomania-Operación Autocollant-Opération		



**WACKER
NEUSON**

**Generator Service Parts
Generatorenersatzteile
Repuestos para Generadores
Pièces Détachées des Groupes Électrogènes**

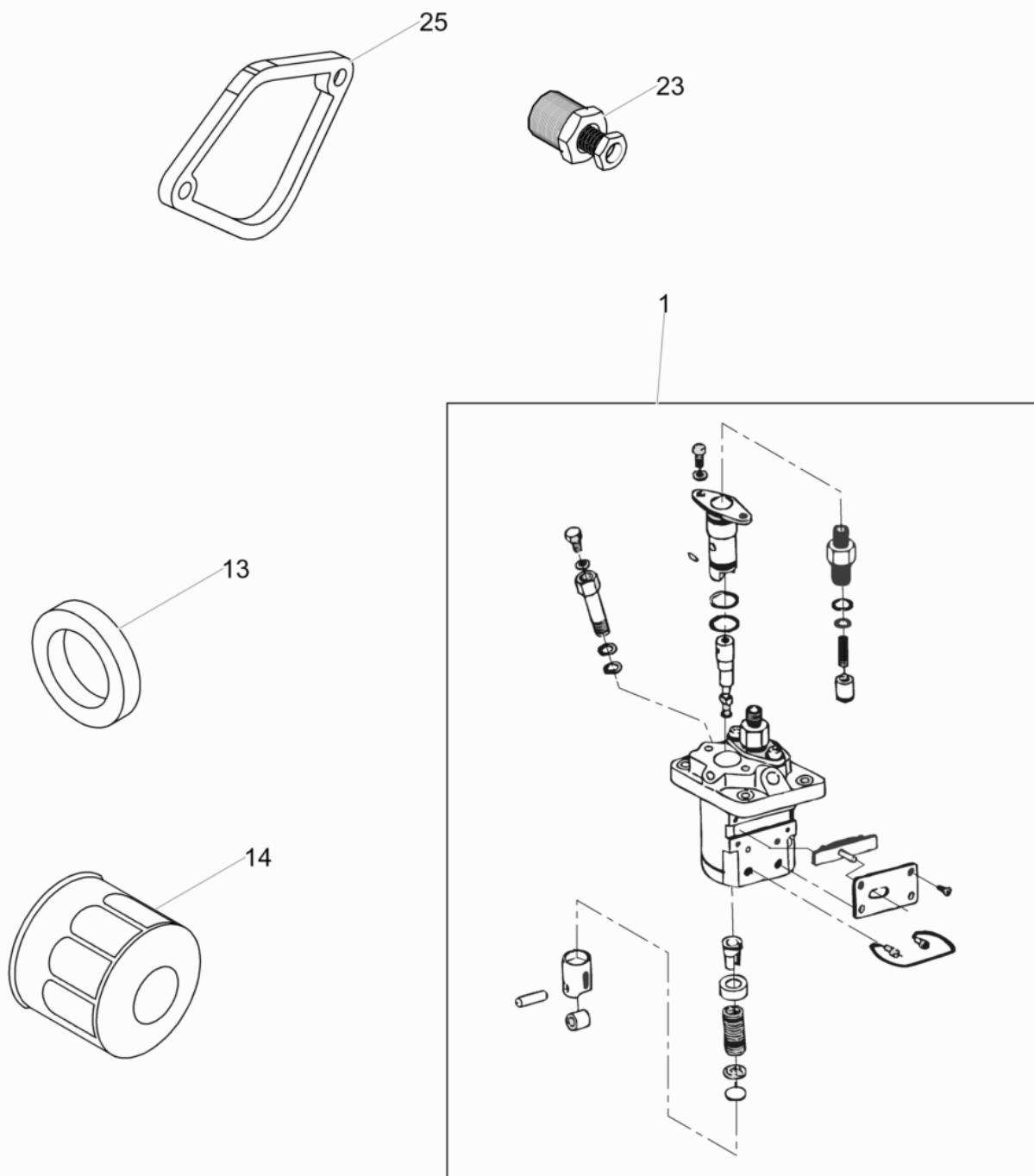

ghiex0168754100_01

Ref. Pos.	Part No. Artikel Nr.	Qty. St.	Description Beschreibung	Descripción Description	Measurem./Abm.	Norm
					Torque/Drehm.	Sealant Schmierstoff
1	0176545	1	Injection Pump Kit Einspritzpumpesatz	Juego de Bomba Inyectora Jeu de Pompe d'Injection		
13	0176544	1	Oil seal Öldichtung	Empaque de aceite Joint d'huile		
14	0169158	1	Oil filter Ölfilter	Filtro de aceite Filtre d'huile		
23	0176482	1	Pressure switch Druckschalter	Interruptor de Presión Interrupteur à Pression		
25	0176517	1	Gasket Dichtung	Junta Joint		

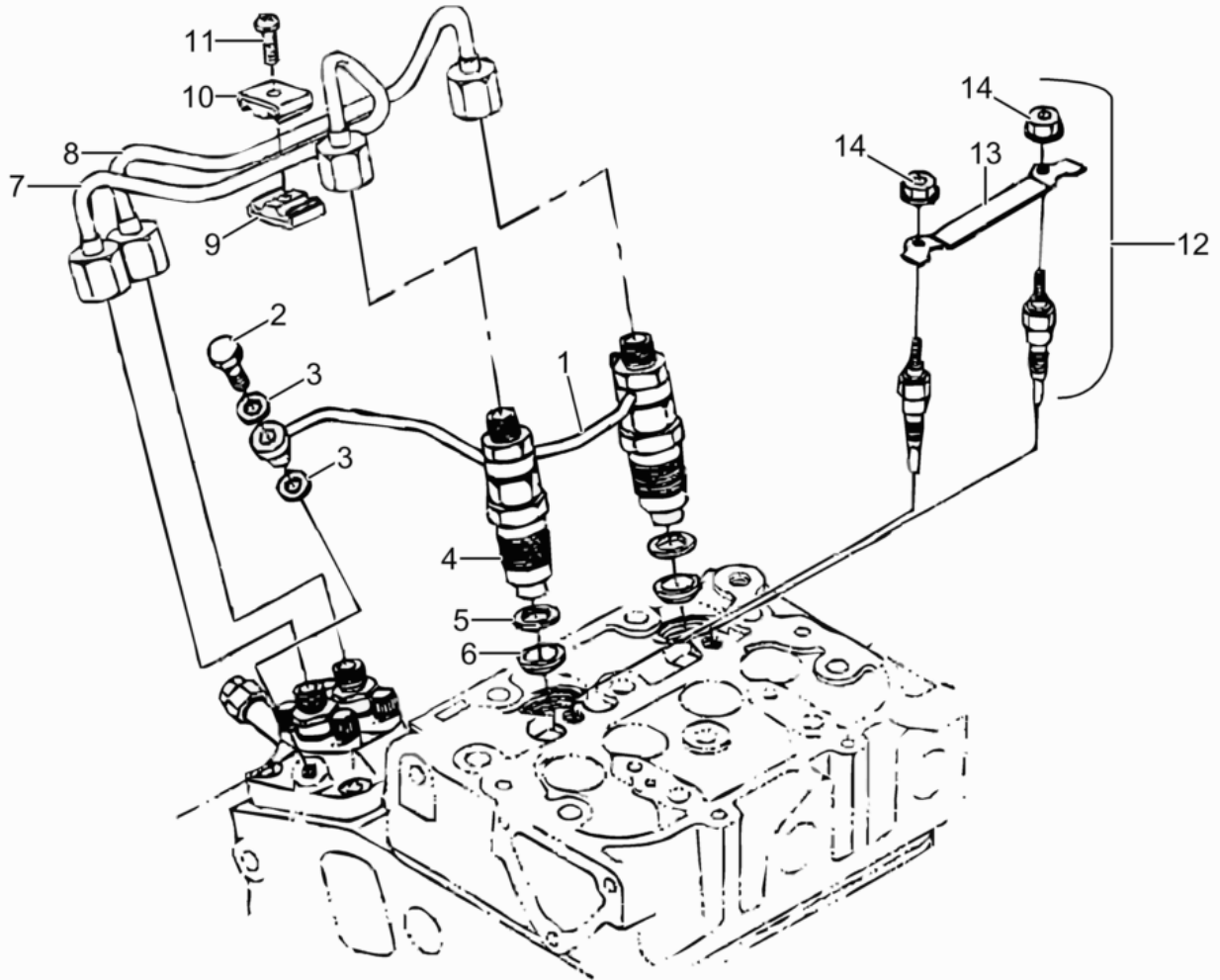

ghiex0168754100_02

Ref. Pos.	Part No. Artikel Nr.	Qty. St.	Description Beschreibung	Descripción Description	Measurement/Abm.	Norm
					Torque/Drehm.	Sealant Schmierstoff
1	0176518	1	Overflow hose Überlaufschlauch	Manguera de rebose Tuyau de trop-plein		
2	0176519	1	Bleed screw Ablassschraube	Tornillo sangrador Vis de vidange		
3	0176520	2	Gasket Dichtung	Junta Joint		
4	0176521	2	Nozzle body (holder) Düse	Tobera Ajutage		
5	0176522	2	Gasket Dichtung	Junta Joint		
6	0176523	2	Seal Dichtung	Empaque Joint		
7	0176524	1	Injection pipe Einspritzrohr	Tubo inyector Tube d'injection		
8	0176525	1	Injection pipe Einspritzrohr	Tubo inyector Tube d'injection		
9	0176526	1	Clamp Schelle	Abrazadera Agrafe		
10	0176527	1	Clamp Schelle	Abrazadera Agrafe		
11	0176528	1	Pan head screw Flachkopfschraube	Tornillo de cabeza de cono achatado Vis ber		
12	0176529	2	Glow plug Glühkerze	Tapón luminoso Bougie de préchauffage		
13	0176530	2	Wire-glow plug Glühkerzenkabel	Alambre para tapón encendedor Fil pour bougie de préchauffage		
14	0176531	2	Flange nut Flanschmutter	Tuerca de reborde Ecrou de bride		

Cylinder Head Cover
Zylinderkopfhaube
Tapa del Cilindro
Couvercle Supérieur

HSH 700G

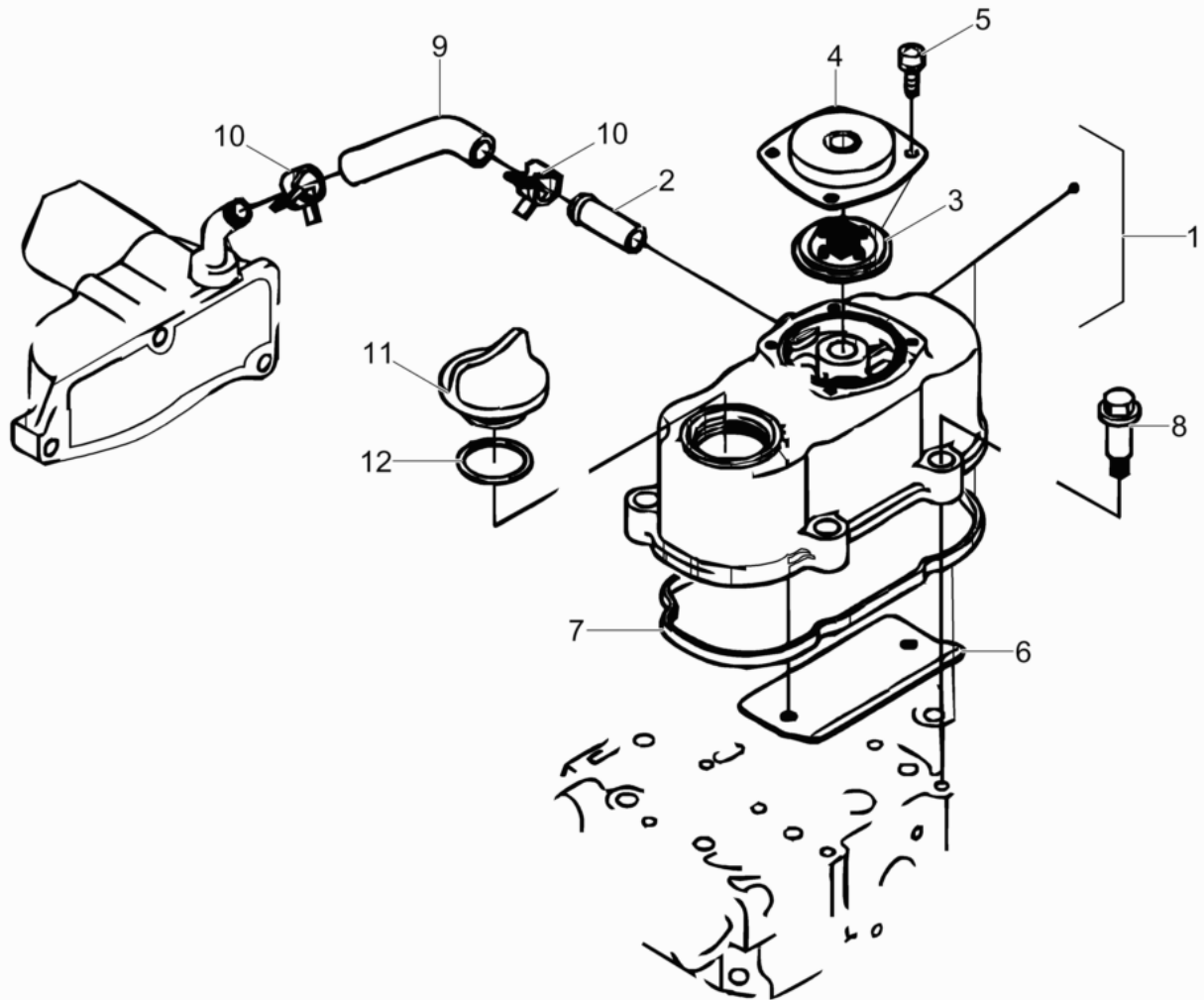

ghiex0168754100_03

Ref. Pos.	Part No. Artikel Nr.	Qty. St.	Description Beschreibung	Descripción Description	Measurement./Abm.	Norm
					Torque/Drehm.	Sealant Schmierstoff
1	0176532	1	Cylinder Head Cover Zylinderkopfhaube	Tapa del Cilindro Couvercle Supérieur		
2	0176574	1	Return pipe Rückleitungsrohr	Tubo de retorno Tuyau de retour		
3	0176534	1	Breather valve Entlüftungsventil	Válvula de ventilación Soupape reniflard		
4	0176535	1	Cover Deckel	Tapa Couvercle		
5	0176536	4	Screw w/washer Schraube mit Scheibe	Tornillo con arandela Vis avec rondelle		
6	0176537	1	Cover plate Deckplatte	Placa de cubierta Couvercle de protection		
7	0176538	1	Gasket Dichtung	Junta Joint		
8	0176539	4	Bolt Bolzen	Perno Boulon		
9	0176540	1	Tube-breather Entlüftungsrohr	Tubo respiradero Tube reniflard		
10	0176541	2	Hose clamp Schlauchschele	Abrazaderas de manguera Agrafe de tuyau		
11	0176542	1	Cap Kappe	Tapa Capuchon		
12	0176543	1	O-Ring O-Ring	Anillo-O Joint torique		

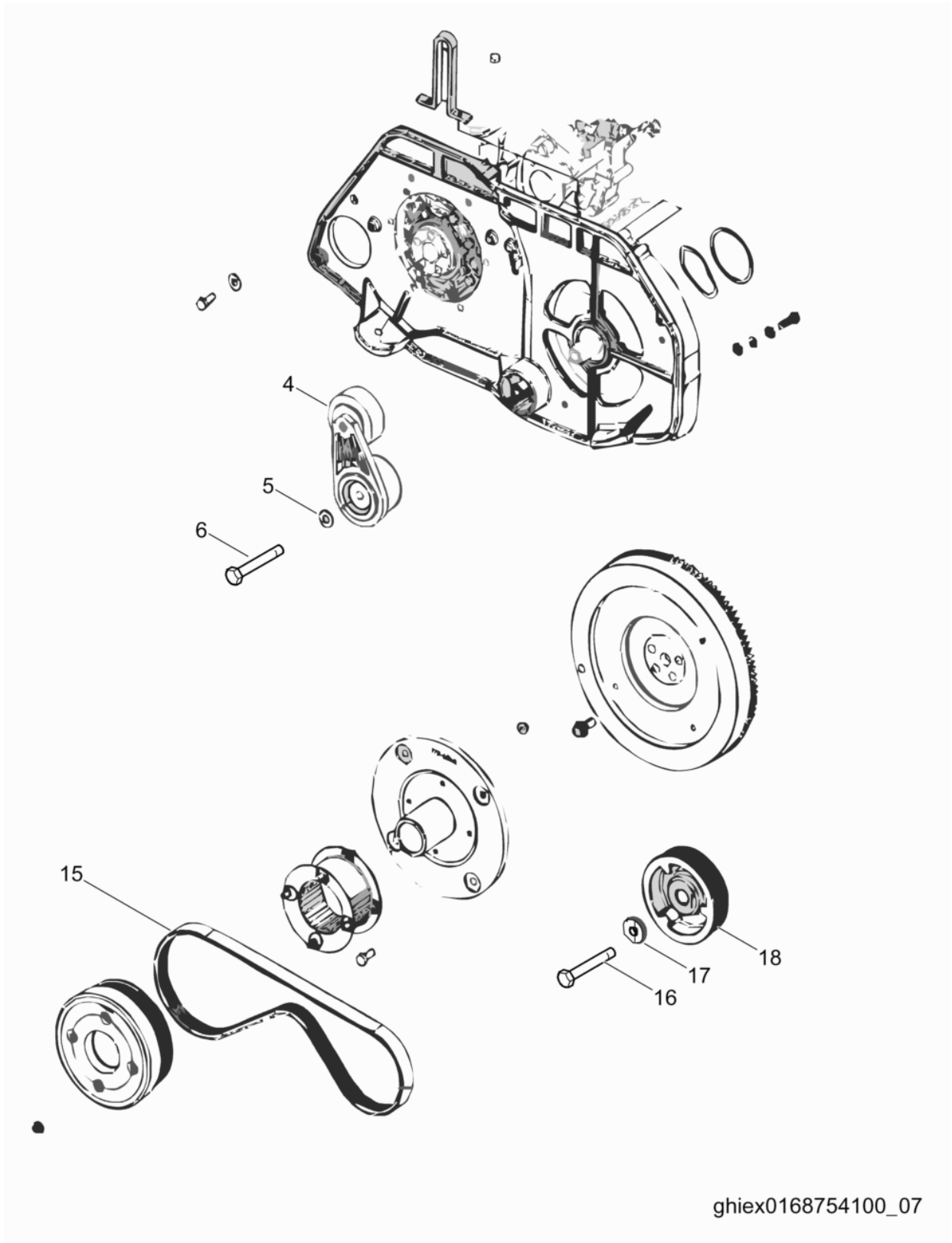

ghiex0168754100_07

Ref. Pos.	Part No. Artikel Nr.	Qty. St.	Description Beschreibung	Descripción Description	Measurement./Abm.	Norm
					Torque/Drehm.	Sealant Schmierstoff
4	0176546	1	Belt tensioner Riemenspannrolle	Polea tensora de correa Tendeur de courroie		
5	0176547	1	Flat washer Scheibe	Arandela elástica Rondelle de ressort	M10	
6	0176548	1	Screw Schraube	Tornillo Vis	3/8 x 16 x 2	
15	0176549	1	Belt Zahnriemen	Correa Courroie		
16	0176550	1	Screw Schraube	Tornillo Vis	M10 x 1	
17	0176551	1	Flat washer Scheibe	Arandela elástica Rondelle de ressort		
18	0176552	1	Pulley Scheibe	Polea Poulie		

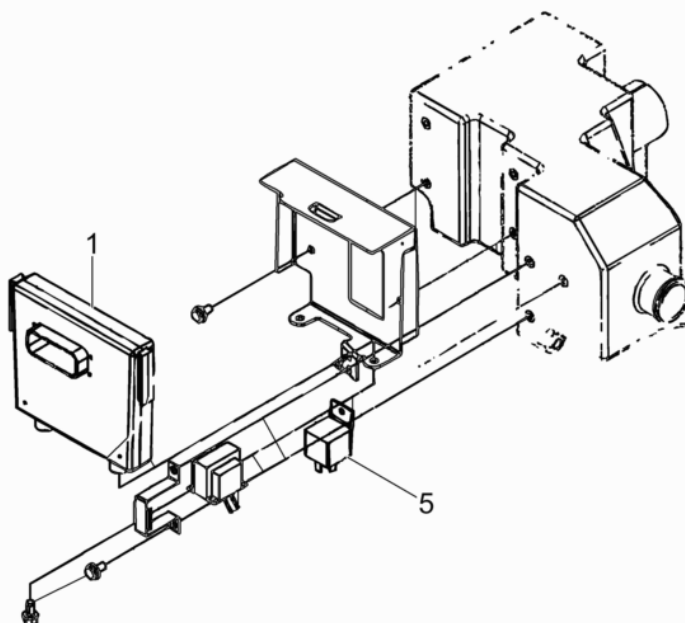
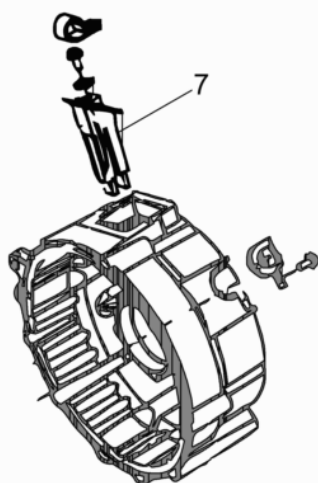
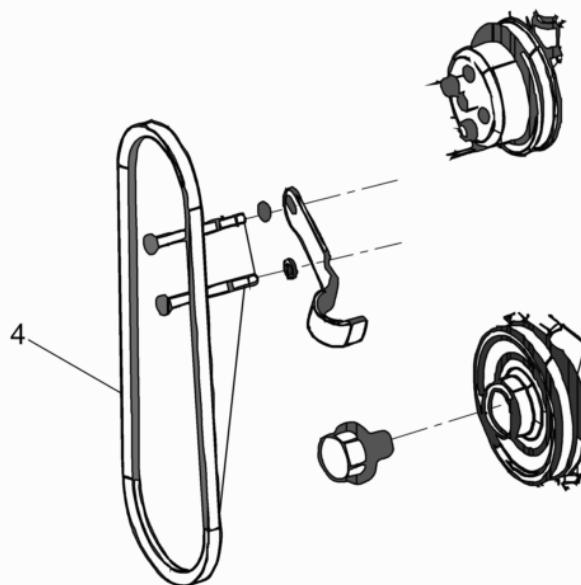
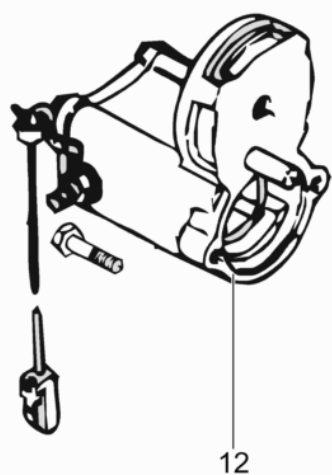

ghiex0168754100_08

Ref. Pos.	Part No. Artikel Nr.	Qty. St.	Description Beschreibung	Descripción Description	Measurement./Abm.	Norm
					Torque/Drehm.	Sealant Schmierstoff
1	0169176	1	Printed circuit board cpl., control Leiterplatte, kpl., Betätigung	Acopl. de tarjeta de circuitoscontrol Carte de circuit imprimé complcommande		
4	0174081	1	Belt Zahnriemen	Correa Courroie		
5	0169171	1	Relay Relais	Relai Relais		
7	0176633	1	Brush Kohlenbürste	Escobilla Balai de charbon		
12	0169168	1	Switch cpl. Schalter	Interruptor Interrupteur		

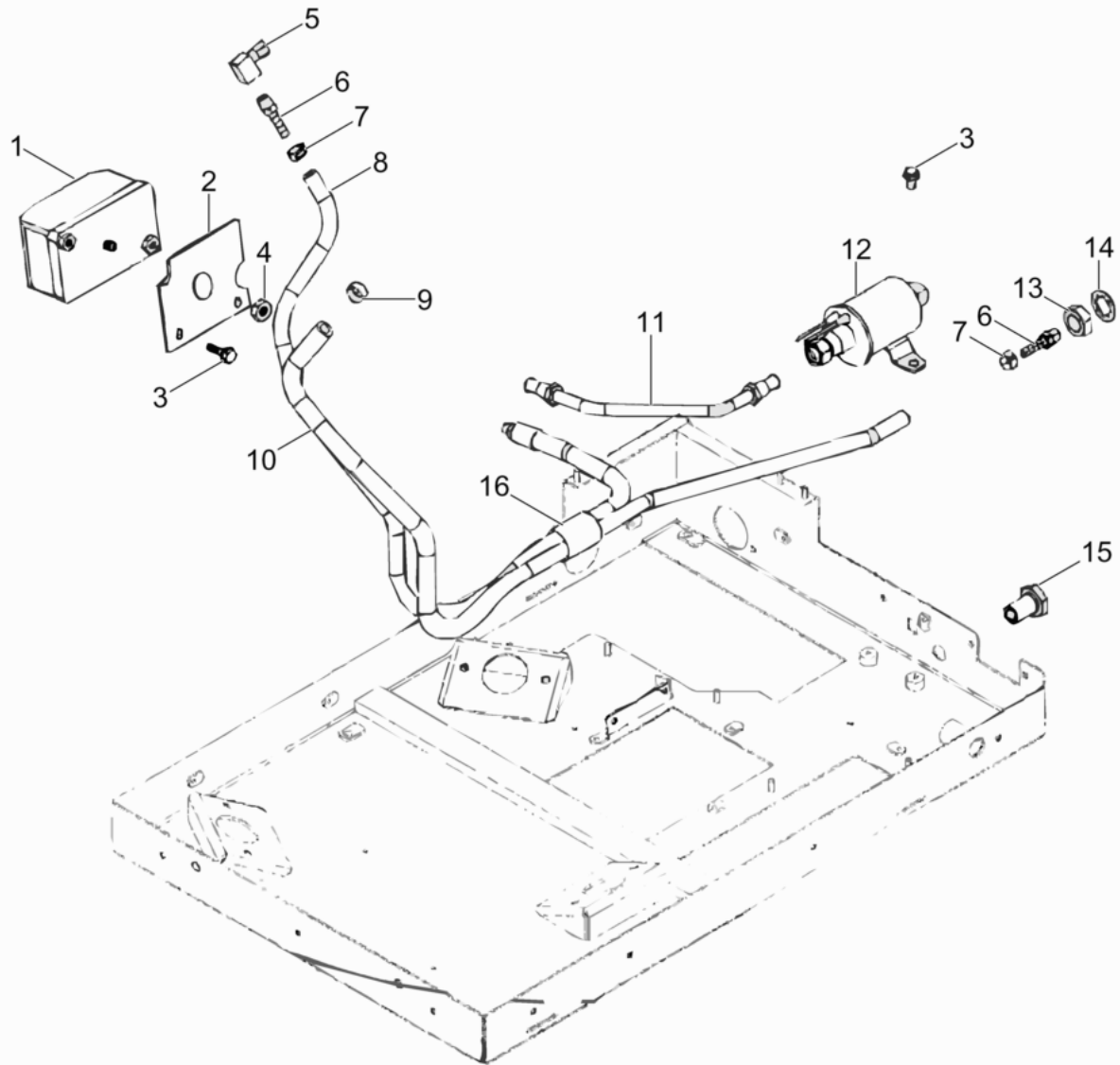

ghiex0168754100_09

Ref. Pos.	Part No. Artikel Nr.	Qty. St.	Description Beschreibung	Descripción Description	Measurement/Abm.	Norm
					Torque/Drehm.	Sealant Schmierstoff
1	0169157	1	Filter-fuel Kraftstofffilter	Filtro de combustible Filtre à carburant		
2	0176553	1	Filter bracket Filterhalterung	Ménsula del filtro Support de filtre		
3	0176632	4	Screw w/lockwasher Schraube mit Federring	Tornillo con arandela elástica Vis avec rondelle de ressort		
4	0176555	1	Lock nut Sicherungsmutter	Contratuerca Contre-écrou		
5	0176556	1	Elbow adapter Rohrkrümmter	Adaptador ele Raccord coudé		
6	0176557	2	Hose barb Schlauchwiderhaken	Púa de manguera Barbelure de flexible		
7	0176558	2	Hose clamp Schlauchschelle	Abrazaderas de manguera Agrafe de tuyau		
8	0176559	1	Fuel Hose Kraftstoffleitung	Manguera de combustible Tuyau de carburant		
9	0176560	1	Hose clamp Schlauchschelle	Abrazaderas de manguera Agrafe de tuyau		
10	0176561	1	Fuel Hose Kraftstoffleitung	Manguera de combustible Tuyau de carburant		
11	0176562	1	Fuel Hose Kraftstoffleitung	Manguera de combustible Tuyau de carburant		
12	0176563	1	Fuel Pump Kraftstoffpumpe	Bomba de Combustible Pompe à Carburant		
13	0176564	1	Hexagon nut Sechskantmutter	Tuerca hexagonal Écrou hexagonal		
14	0176565	1	Lock washer Federring	Federring Rondelle de ressort		
15	0176566	1	Adapter Adapter	Adaptador Raccord		
16	0176567	1	Clamp Schelle	Abrazadera Agrafe		

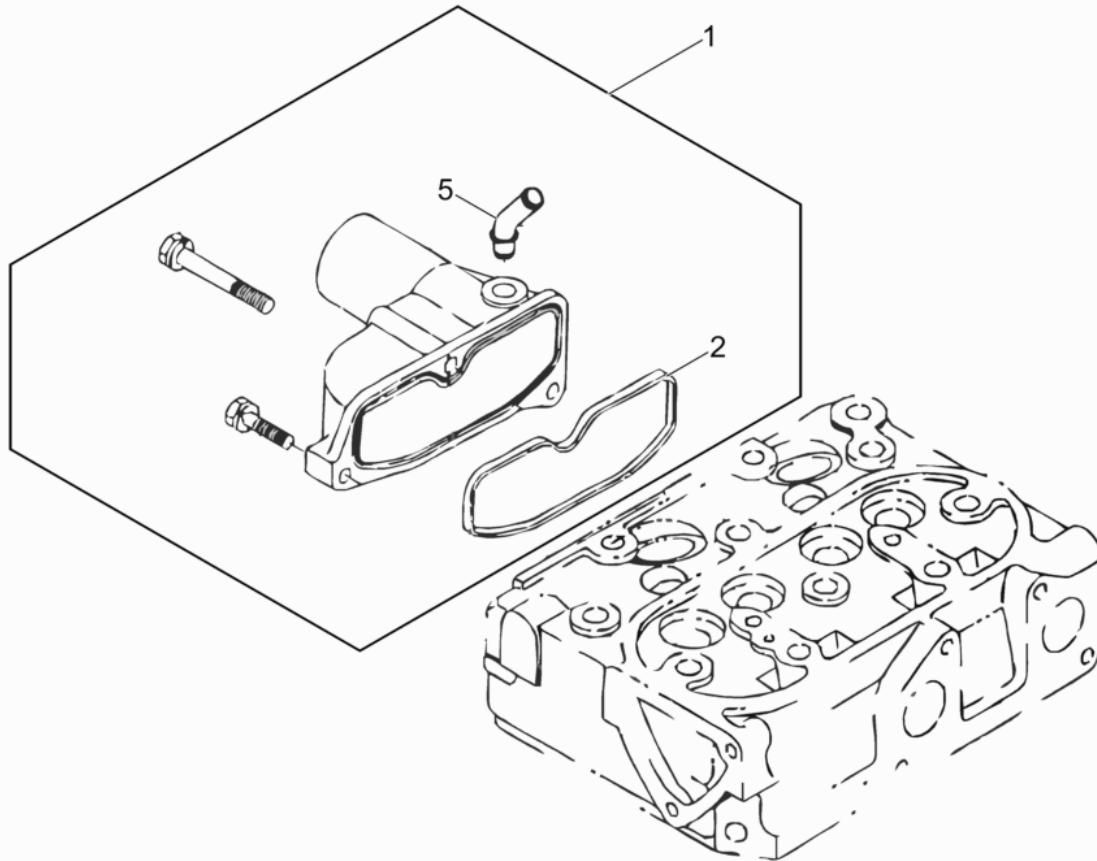

ghiex0168754100_10

Ref. Pos.	Part No. Artikel Nr.	Qty. St.	Description Beschreibung	Descripción Description	Measurement./Abm.	Norm
					Torque/Drehm.	Sealant Schmierstoff
1	0176568	1	Inlet valve Einlaßventil	Válvula de admisión Soupape d'admission		
2	0176569	1	Gasket Dichtung	Junta Joint		
5	0176570	1	Breather tube Entlüftungsrohr	Tubo respiradero Tube reniflard		

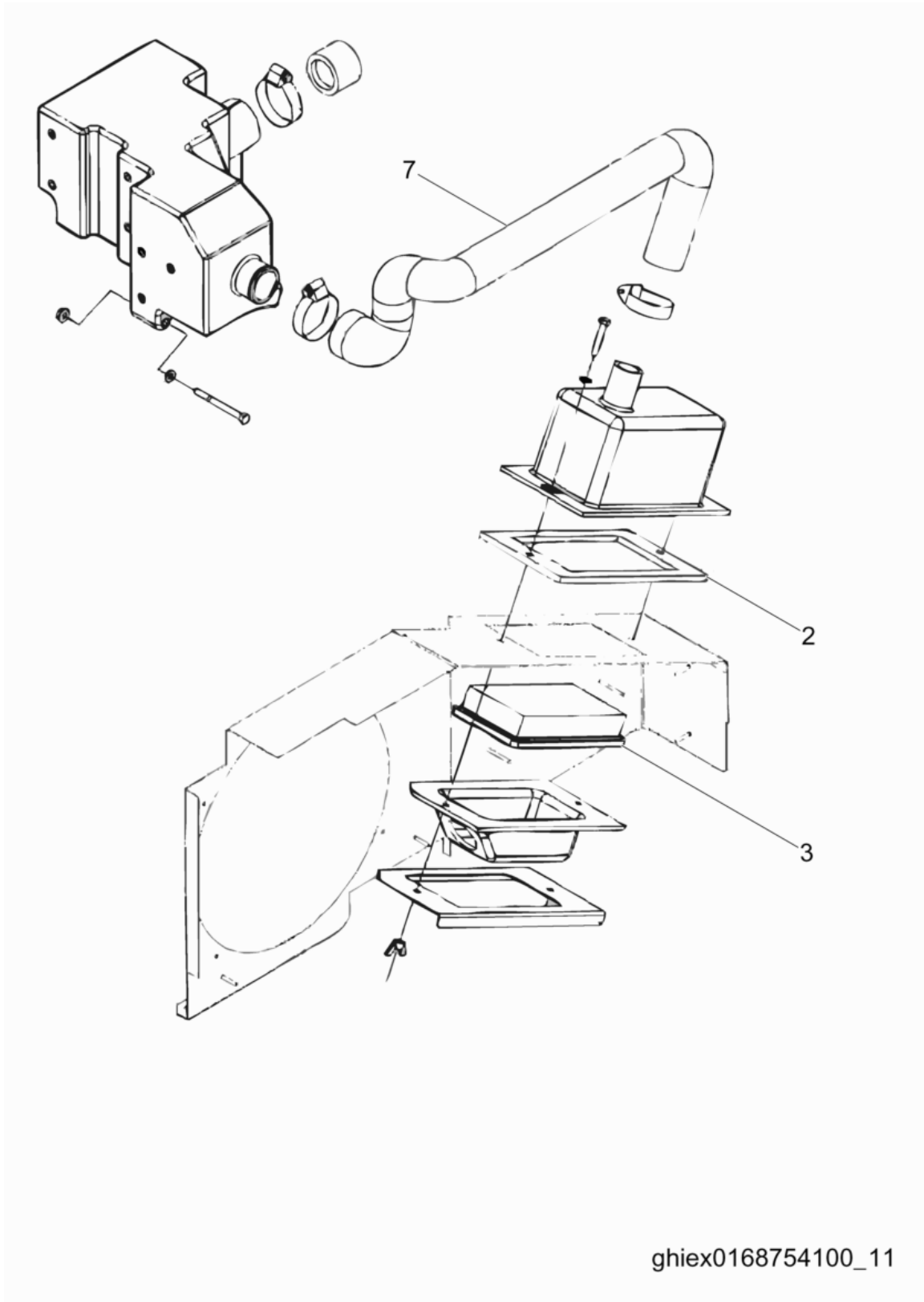

Ref. Pos.	Part No. Artikel Nr.	Qty. St.	Description Beschreibung	Descripción Description	Measurem./Abm.	Norm
					Torque/Drehm.	Sealant Schmierstoff
2	0176571	1	Gasket Dichtung	Junta Joint		
3	0169156	1	Air filter Luftfilter	Filtro del aire Filtre à air		
7	0176572	1	Air hose Druckluftschlauch	Manguera de aire Tuyau à air		

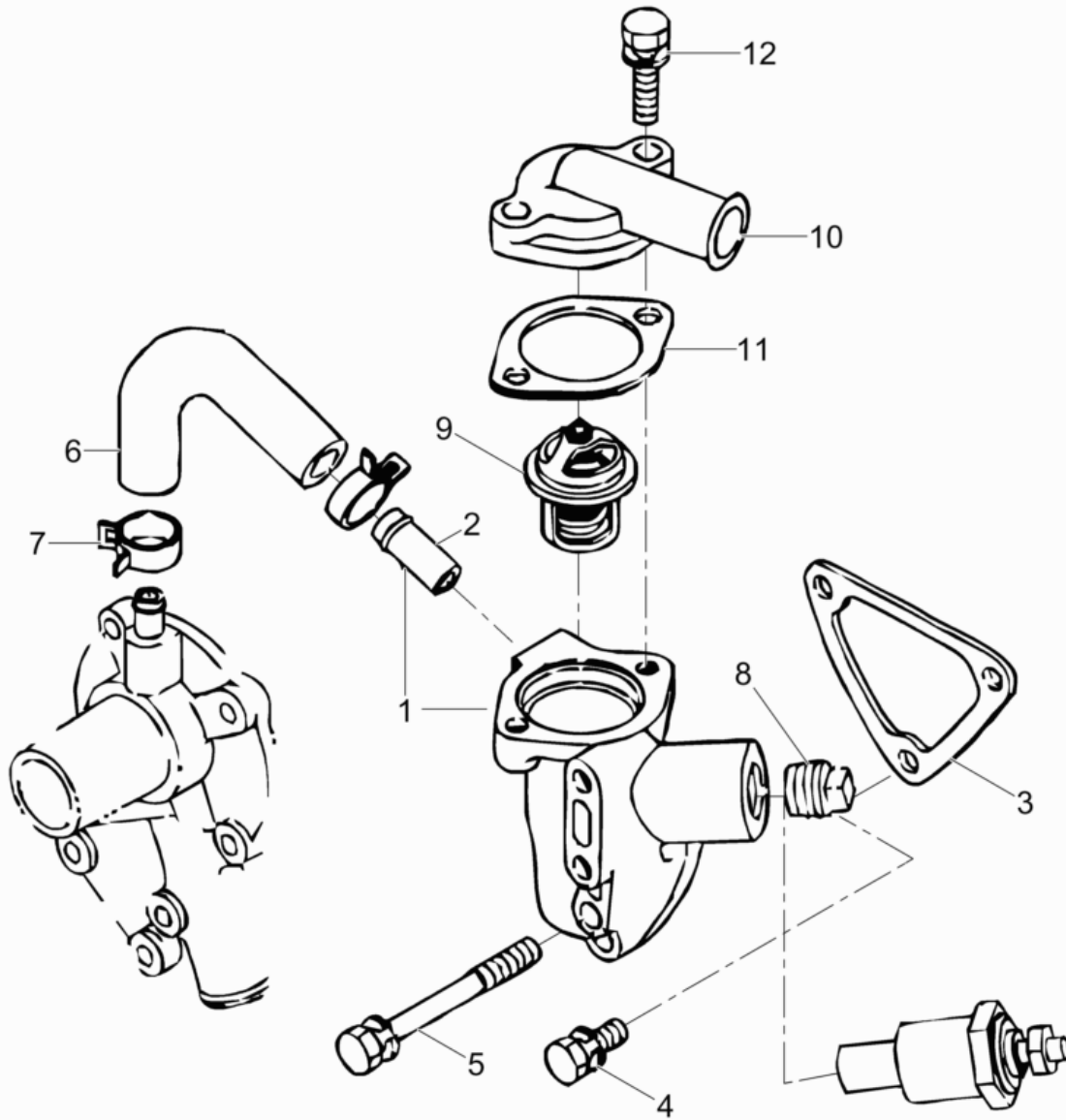

ghiex0168754100_12

Ref. Pos.	Part No. Artikel Nr.	Qty. St.	Description Beschreibung	Descripción Description	Measurem./Abm.	Norm
					Torque/Drehm.	Sealant Schmierstoff
1	0176573	1	Flange Flansch	Brida Collerette		
2	0176574	1	Return pipe Rückleitungsrohr	Tubo de retorno Tuyau de retour		
3	0176575	1	Gasket Dichtung	Junta Joint		
4	0176576	2	Bolt Bolzen	Perno Boulon		
5	0176577	1	Bolt Bolzen	Perno Boulon		
6	0176578	1	Return pipe Rückleitungsrohr	Tubo de retorno Tuyau de retour		
7	0176579	2	Hose clamp Schlauchschele	Abrazaderas de manguera Agrafe de tuyau		
8	0176580	1	Plug Stopfen	Tapón Bouchon		
9	0176581	1	Thermostat Temperaturregler	Termóstato Thermostat		
10	0176582	1	Thermostat cover Thermostatdeckel	Tapa del termóstato Couvercle du thermostat		
11	0176583	1	Gasket Dichtung	Junta Joint		
12	0176584	2	Bolt Bolzen	Perno Boulon		
13	0176585	1	Temperature sender Temperatursender	Transmisor de temperatura Transmetteur de température		

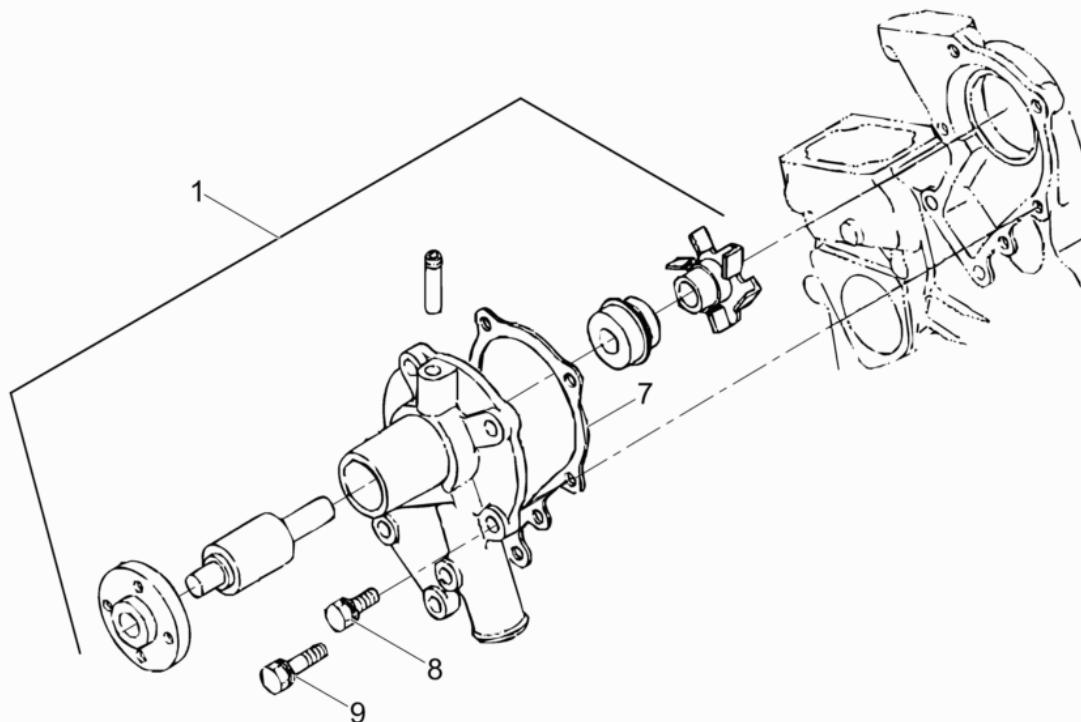

ghiex0168754100_13

Ref. Pos.	Part No. Artikel Nr.	Qty. St.	Description Beschreibung	Descripción Description	Measurem./Abm.	Norm
					Torque/Drehm.	Sealant Schmierstoff
1	0176586	1	Water Pump Kit Wasserpumpe kompl	Bomba del agua compl. Pompe à eau compl.		
7	0176587	1	Gasket Dichtung	Junta Joint		
8	0176588	5	Bolt Bolzen	Perno Boulon		
9	0176589	2	Bolt Bolzen	Perno Boulon		

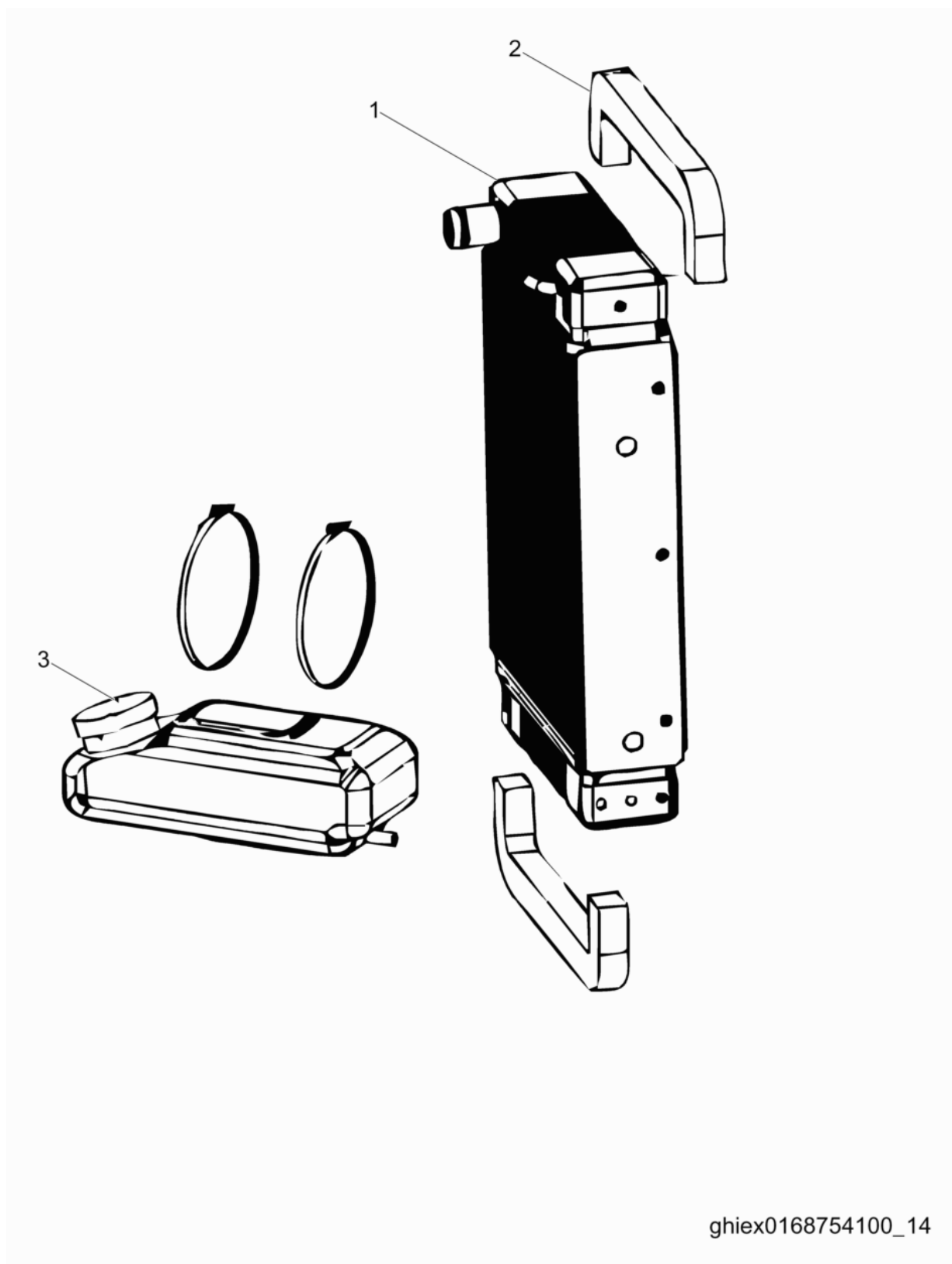

ghiex0168754100_14

Ref. Pos.	Part No. Artikel Nr.	Qty. St.	Description Beschreibung	Descripción Description	Measurem./Abm.	Norm
					Torque/Drehm.	Sealant Schmierstoff
1	0176590	1	Radiator Kühler	Radiador Radiateur		
2	0176591	2	Seal Dichtung	Empaque Joint		
3	0176592	1	Reservoir tank Tankbehälter	Tanque del depósito Réservoir		

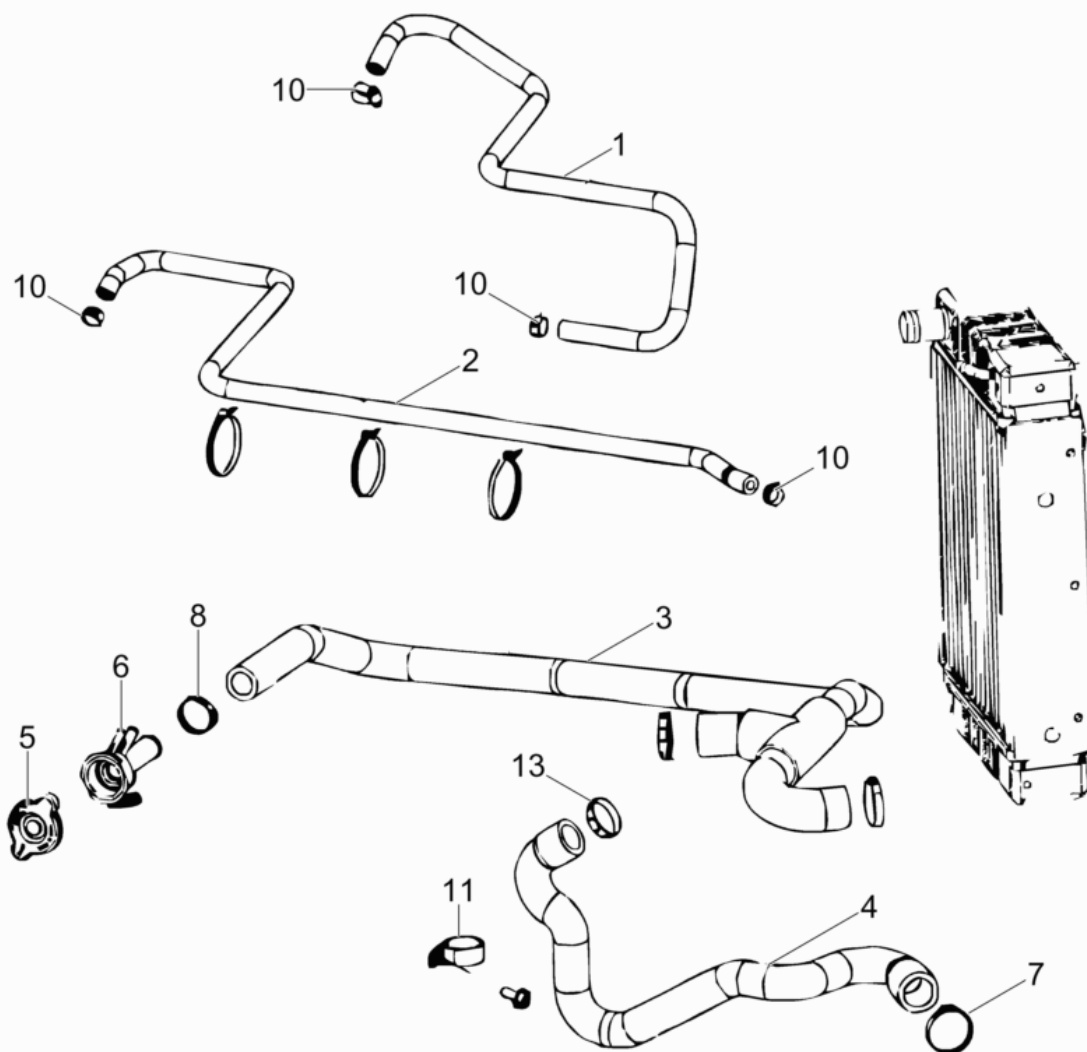

ghiex0168754100_15

Ref. Pos.	Part No. Artikel Nr.	Qty. St.	Description Beschreibung	Descripción Description	Measurement./Abm.	Norm
					Torque/Drehm.	Sealant Schmierstoff
1	0176596	1	Air hose Druckluftschlauch	Manguera de aire Tuyau à air		
2	0176597	1	Air hose Druckluftschlauch	Manguera de aire Tuyau à air		
3	0176598	1	Hose Schlauch	Manguera Tuyau		
4	0176599	1	Hose Schlauch	Manguera Tuyau		
5	0169162	1	Cap-coolant fill Kappe	Tapa Capuchon		
6	0176601	1	Filler tube Füllrohr	Tubo de llenado Tube de remplisseur		
7	0176602	3	Hose clamp Schlauchselle	Abrazaderas de manguera Agrafe de tuyau		
8	0176603	1	Hose clamp Schlauchselle	Abrazaderas de manguera Agrafe de tuyau		
10	0176604	4	Hose clamp Schlauchselle	Abrazaderas de manguera Agrafe de tuyau		
11	0176605	1	Cable clamp Kabelhalter	Abrazadera para cable Attache de câble		
13	0176606	1	Hose clamp Schlauchselle	Abrazaderas de manguera Agrafe de tuyau		

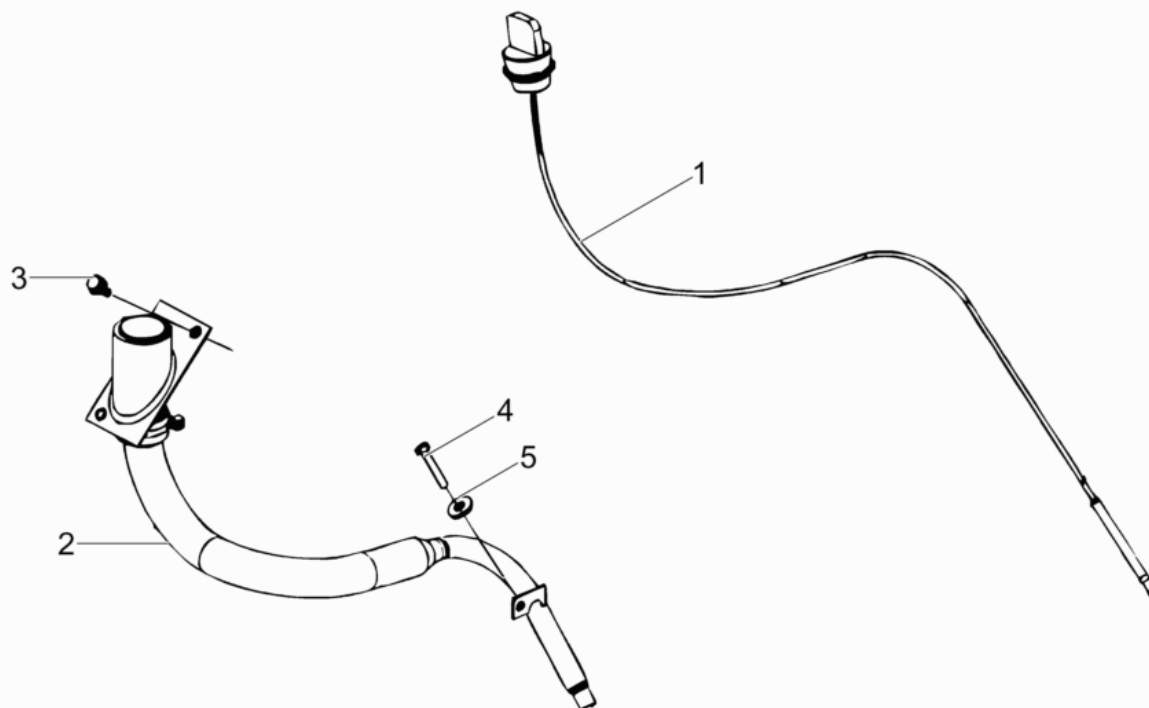

ghiex0168754100_17

Ref. Pos.	Part No. Artikel Nr.	Qty. St.	Description Beschreibung	Descripción Description	Measurement/Abm.	Norm
					Torque/Drehm.	Sealant Schmierstoff
1	0170467	1	Dipstick Peilstab	Indicador del nivel de aceite Réglette-jauge		
2	0176608	1	Oil fill tube Ölfüllerrohr	Tubo llenador de aceite Tube-remplisseur d'huile		
3	0176632	2	Screw w/lockwasher Schraube mit Federring	Tornillo con arandela elástica Vis avec rondelle de ressort		
4	0176610	1	Hex head screw Sechskantschraube	Tornillo Vis à tête hexagonale		
5	0176611	1	Flat washer Scheibe	Arandela elástica Rondelle de ressort		

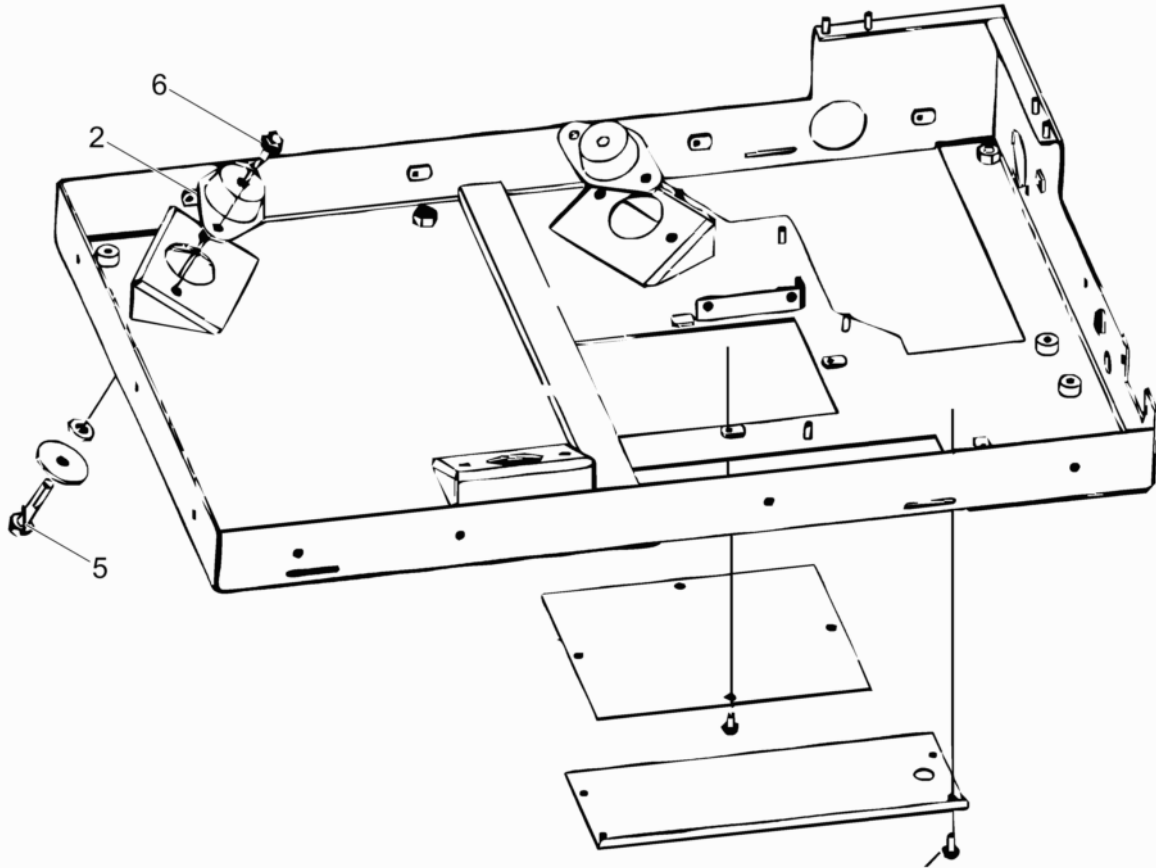

ghiex0168754100_19

Ref. Pos.	Part No. Artikel Nr.	Qty. St.	Description Beschreibung	Descripción Description	Measurement./Abm.	Norm
					Torque/Drehm.	Sealant Schmierstoff
2	0176613	3	Isolator pad Unterlage des Isolators	Cojín del aislador Coussin de l'isolant		
5	0176614	3	Threaded bolt Schraubbolzen	Perno roscado Boulon fileté	M10 x 1	
6	0176615	6	Hex head screw Sechskantschraube	Tornillo Vis à tête hexagonale	M8 x 1	

Exhaust manifold

Auspuffkrümmer

Distribuidor de escape

Collecteur d'échappement

HSH 700G

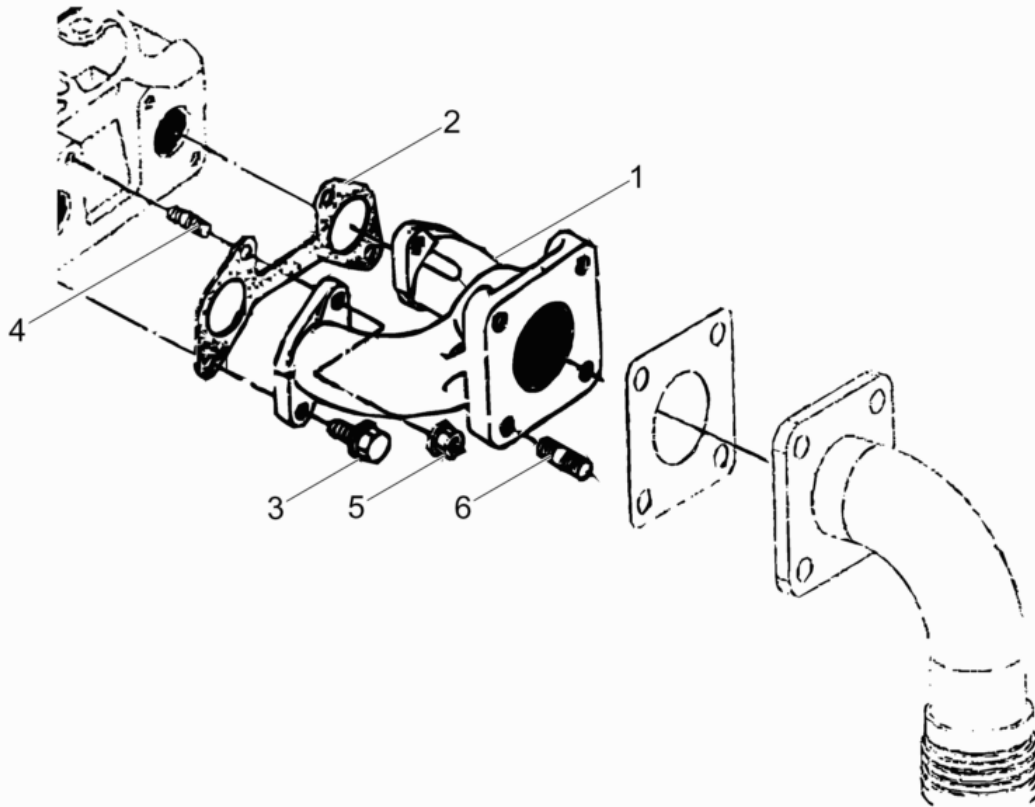

ghiex0168754100_20

Ref. Pos.	Part No. Artikel Nr.	Qty. St.	Description Beschreibung	Descripción Description	Measurem./Abm.	Norm
					Torque/Drehm.	Sealant Schmierstoff
1	0176616	1	Exhaust manifold Auspuffkrümmer	Distribuidor de escape Collecteur d'échappement		
2	0176617	1	Gasket Dichtung	Junta Joint		
3	0176618	2	Bolt Bolzen	Perno Boulon		
4	0176619	2	Stud Gewindebolzen	Perno prisionero Goujon		
5	0176620	2	Nut Mutter	Tuerca Écrou		
6	0176621	4	Stud Gewindebolzen	Perno prisionero Goujon		

Muffler cpl.
Auspufftopf kpl.

HSH 700G

Silenciador compl.
Pot d'Echappement compl.

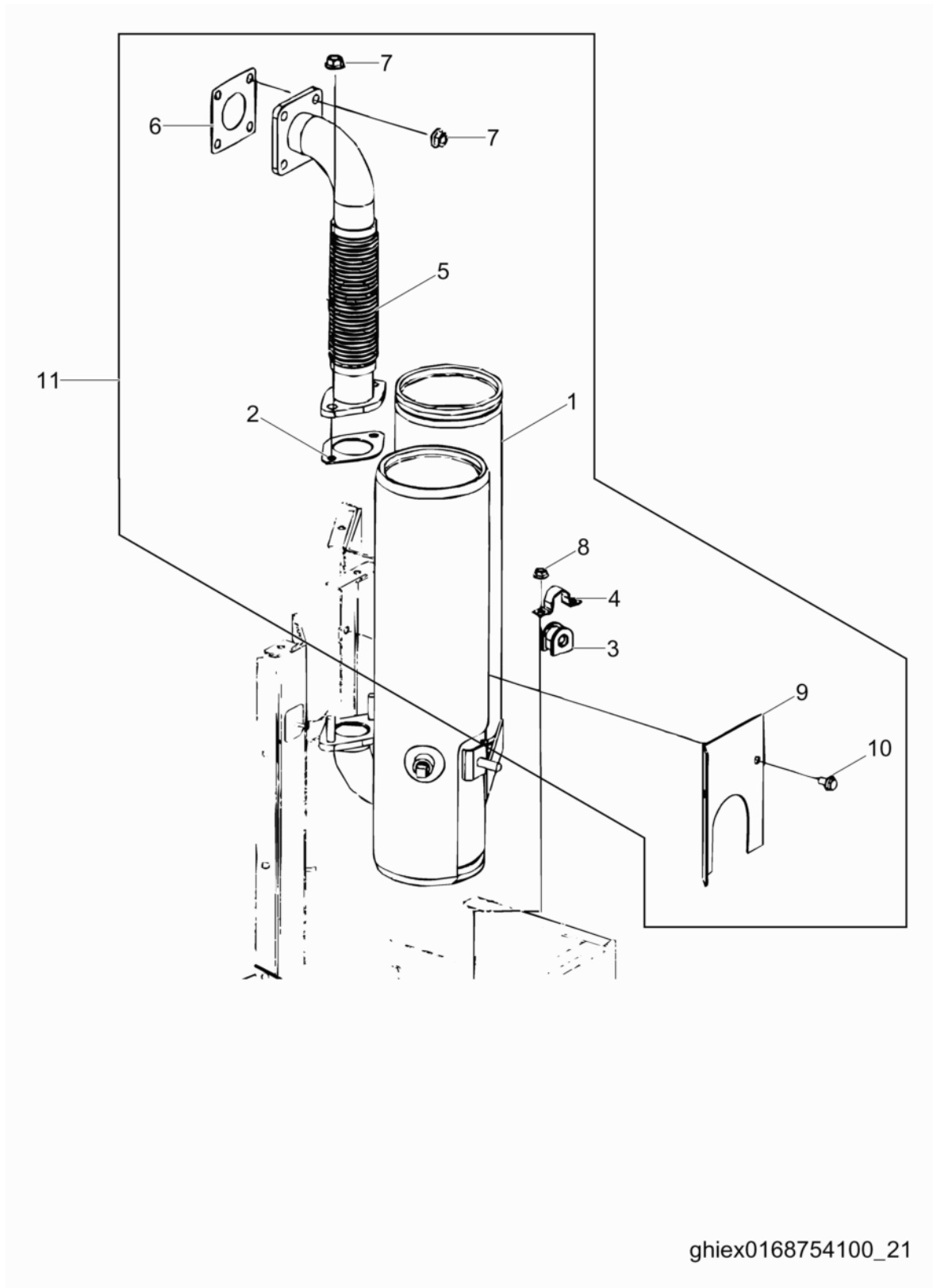

Ref. Pos.	Part No. Artikel Nr.	Qty. St.	Description Beschreibung	Descripción Description	Measurement/Abm.	Norm
					Torque/Drehm.	Sealant Schmierstoff
1	0176623	1	Muffler Auspufftopf	Silenciador Pot d'échappement		
2	0176624	1	Gasket Dichtung	Junta Joint		
3	0176625	1	Isolator mount Isolatorkonsole	Ménsula de aislante Support d'isolant		
4	0176626	1	Clamp Schelle	Abrazadera Agrafe		
5	0176627	1	Exhaust pipe Auspuffrohr	Tubo de escape Tuyau d'échappement		
6	0176628	1	Gasket Dichtung	Junta Joint		
7	0176629	6	Hex nut Sechskantmutter	Tuerca hexagonal Écrou six-pans		
8	0176630	2	Hex nut Sechskantmutter	Tuerca hexagonal Écrou six-pans		
9	0176631	1	Bracket Konsole	Soporte Support		
10	0176632	2	Screw w/lockwasher Schraube mit Federring	Tornillo con arandela elástica Vis avec rondelle de ressort		
11	0176622	1	Muffler Kit Satz-Auspufftopf	Juego-silenciador Jeu-pot d'échappement		

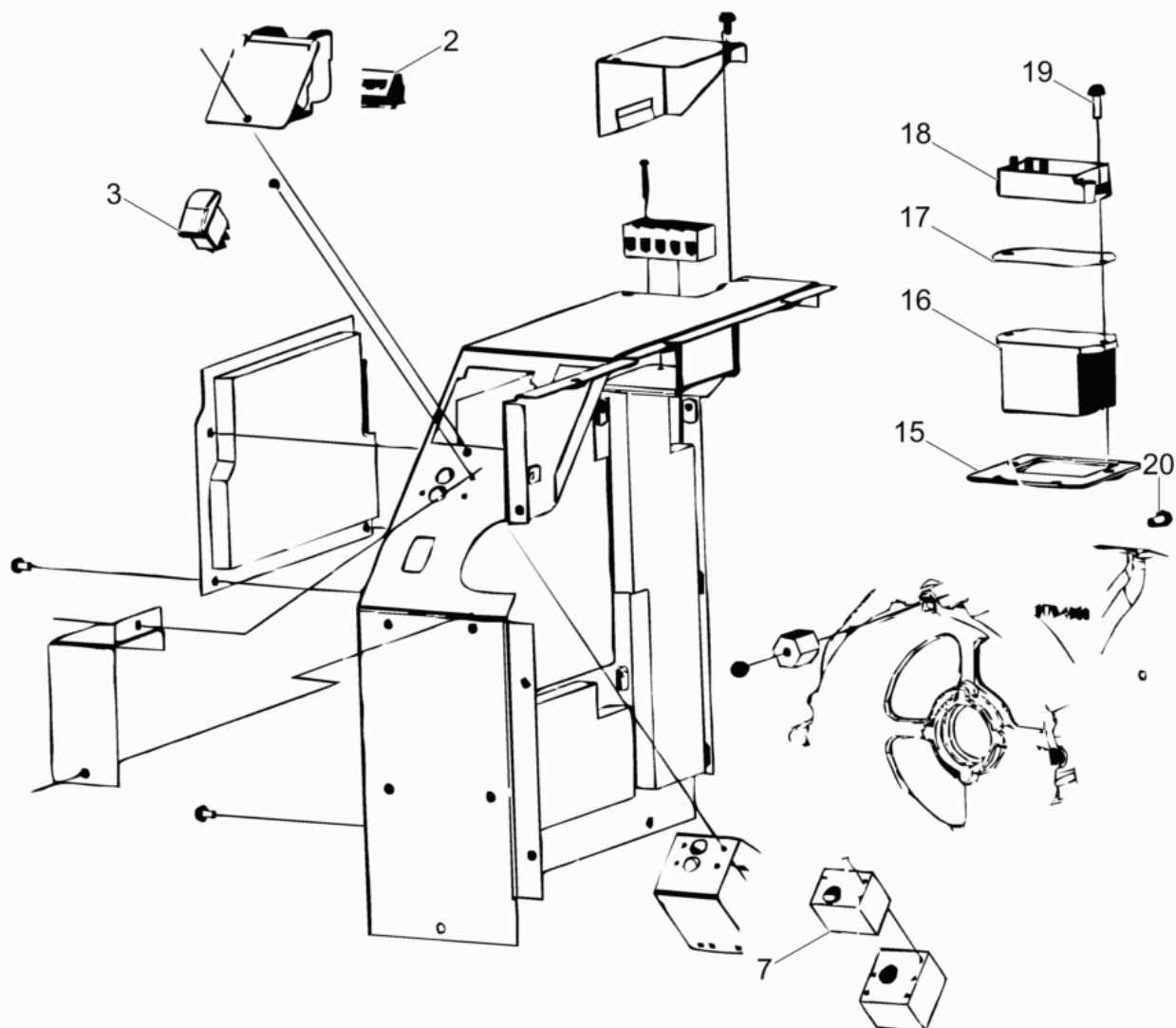

ghiex0168754100_23

Ref. Pos.	Part No. Artikel Nr.	Qty. St.	Description Beschreibung	Descripción Description	Measurement/Abm.	Norm
					Torque/Drehm.	Sealant Schmierstoff
2	0176634	1	Hour meter Stundenzähler	Horometro Compteur horaire		
3	0169172	1	Switch Schalter	Interruptor Interrupteur		
7	0176635	1	Circuit breaker Unterbrecher	Interruptor de circuito Coupe-circuit		
15	0176636	1	Bracket Konsole	Soporte Support		
16	0176637	1	Heat sink Kühlblock	Dispensor de calor Dissipateur de chaleur		
17	0176638	1	Pad Unterlage	Cojín Coussin		
18	0169315	1	Voltage regulator Spannungsregler	Regulador de voltaje Régulateur de tension		
19	0176639	2	Screw w/lockwasher Schraube mit Federring	Tornillo con arandela elástica Vis avec rondelle de ressort		
20	0176640	1	Screw w/locknut Schraube mit Sicherungsmutter	Tornillo con contratuerca Vis avec contre-écrou		

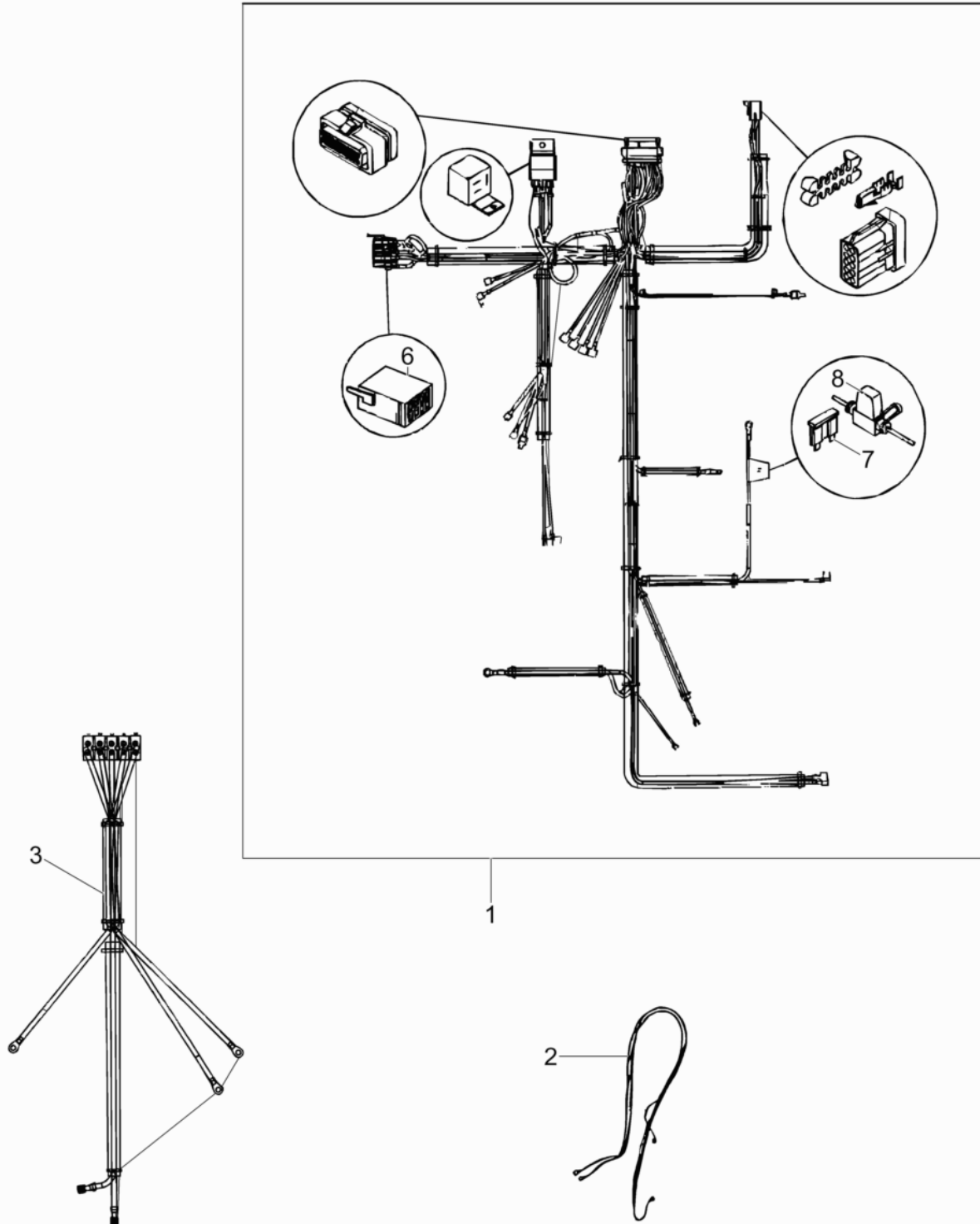

ghiex0168754100_25

Ref. Pos.	Part No. Artikel Nr.	Qty. St.	Description Beschreibung	Descripción Description	Measurement./Abm.	Norm
					Torque/Drehm.	Sealant Schmierstoff
1	0176641	1	Wiring harness Kabelbaum	Conjunto de cables Harnais de câbles électriques		
2	0176645	1	Wiring harness Kabelbaum	Conjunto de cables Harnais de câbles électriques		
3	0176644	1	Wiring harness Kabelbaum	Conjunto de cables Harnais de câbles électriques		
6	0169170	1	Switch Schalter	Interruptor Interrupteur		
7	0176642	1	Fuse Sicherung	Fusible Fusible	30A	
8	0176643	1	Fuse holder Fassung der Sicherung	Portafusible Porte-fusible		



**WACKER
NEUSON**