



**WACKER
NEUSON**

0610033	105
12.2017	

**Single Direction Plates
Vorwärtslaufende Platten
Planchas Vibradoras Unidirecc
Plaques Vibrantes à sens de ma**

DPS 1850H Asphalt

**Parts Book
Ersatzteile
Lista de Repuestos
Liste de Pièces de Rechange**

www.wackerneuson.com

A nameplate listing the Model Number, Item Number, Revision, and Serial Number is attached to each unit. Please record the information found on this plate so it will be available should the nameplate become lost or damaged. When ordering parts or requesting service information, you will always be asked to specify the model, item number, revision number, and serial number of the unit.

Ein Typenschild mit Typ, Artikelnummer, Version und Maschinen-Nummer ist an jedem Gerät angebracht. Die Daten von diesem Schild bitte notieren, damit sie auch bei Verlust oder Beschädigung des Schildes noch vorhanden sind. Der Typ, die Artikel-Nummer, die Versions- Nummer und die Maschinen-Nummer sind bei der Ersatzteilbestellung oder Nachfragen bezüglich Service-Informationen stets erforderlich.

Una placa de identificación con el modelo, número de referencia, nivel de revisión y número de serie ha sido añadida en cada máquina. Favor de anotar los datos en la placa en caso de que la placa de identificación sea destruida o perdida. En todos los pedidos para repuestos necesita siempre el modelo, el número de referencia, el nivel de revisión y el número de serie de la máquina en cuestión.

Une plaque signalétique mentionnant le modèle, le numéro de référence, le niveau de révision et le numéro de série est fixée sur chaque machine. Veuillez noter les informations relevées sur cette plaque de façon à ce qu'elles soient toujours disponibles si la plaque signalétique venait à être perdue ou endommagée. Lorsque vous commandez des pièces détachées ou vous sollicitez des informations après-vente, on vous demandera toujours de préciser le modèle, le numéro de référence, le niveau de révision et le numéro de série de la machine.

***My machine's numbers are / Die Nummern meines Gerätes sind /
Los números de mi máquina son / Les numéros de ma machine son :***

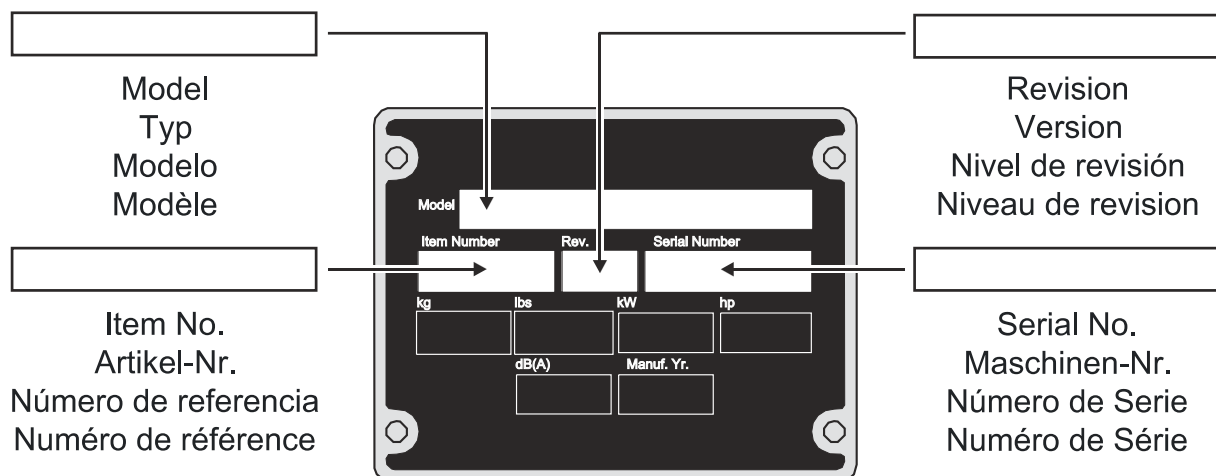

Part Numbers appearing in boldface type are recommended spare parts. This means that these parts are subject to wear under normal operating conditions and may require periodic service or replacement. It is recommended that these items be stocked to meet the expected service requirements of this model. Actual stocking quantities of these and other parts used in more extensive repairs will depend on the service practices of each customer.

Bei den in den Ersatzteillisten fettgedruckten Nummern handelt es sich um empfohlene Ersatzteile. Dies bedeutet, daß diese Teile bei normalen Anwendungsbedingungen natürlicher Abnutzung ausgesetzt sind und gelegentlich ersetzt oder überarbeitet werden müssen. Es wird geraten, diese Teile auf Lager bereit zu haben, um für Service-Arbeiten an diesem Gerät vorbereitet zu sein. Lagerbestände für diese und andere Teile, welche für ausgiebigere Reparaturarbeiten benötigt werden, können je nach Service-Gewohnheiten der einzelnen Kunden variieren.

Los números de partes en negritas en las Listas Ilustradas de Partes son los repuestos recomendados, ésto quiere decir que estas partes se desgastarán bajo circunstancias de funcionamiento normales y pueden requerir servicio periódico o su reemplazo. Se recomienda que el cliente mantenga un abastecimiento adecuado de estas partes para poder satisfacer la demanda requerida por el servicio a la máquina. La cantidad de repuestos que el cliente necesitará para reparaciones dependerá de la póliza de servicio de cada cliente.

Les numéros de pièces imprimés en caractères gras dans les Listes des Pièces Détachées de ce manuel sont les pièces détachées recommandées par la Wacker. Cela veut dire que ces pièces sont sujettes à usure dans des conditions de travail normales et peuvent nécessiter de l'entretien ou leur remplacement. Nous recommandons que vous disposez d'un stock de ces pièces pour pouvoir satisfaire la demande d'entretien de cette machine. Le client doit décider lui-même de la quantité exacte de pièces de rechange qu'il disposera dans ses stocks.

This machine may be covered by one or more of the following patents:
Dieses Gerät ist unter einem oder mehreren der folgenden Patente geschützt:
Puede ser que las patentes a continuación sean válidas para esta máquina:
Cette machine peut être protégée sous les brevets d'invention ci-dessous :

FRG PATENT-Nos.: 199 12 813.8-09, 100 31 617.4-25, 101 16 526.9-09,
102 26 920.3-25, 198 28 600.7-09, 198 28 601.5-09, 199 03 062,
297 01 737.3, G 94 18 184.5, 296 05 664.2, P 42 21 793.8-35,
198 44 462.1-32

OTHER FRG AND FOREIGN PATENTS PENDING

SGF2

Vibratory Plate cpl. Vibrationsplatte kpl. Plancha Vibradora cpl. Plaque Vibrante cpl.	8
Vibratory Plate cpl. Vibrationsplatte kpl. Plancha Vibradora cpl. Plaque Vibrante cpl.	12
Exciter cpl. Erreger kpl. Excitador cpl. Excitateur cpl.	16
Centrifugal Clutch Fliehkraftkupplung Embrague Centrifugo Embrayage Centrifuge	18
Watertank cpl. Wassertank kpl. Tanque de Agua cpl. Reservoir à Eau cpl.	20
Center Pole cpl. Deichsel kpl. Barra de mando cpl. Timon cpl.	22
Label Aufkleber Calcomania Autocollant	24
Engine Motor Motor Moteur	27
Crankcase Kurbelgehäuse Cárter Carter	28
Crankshaft Kurbelwelle Cigüeñal Vilebrequin	32
Camshaft Nockenwelle Árbol de Levas Arbre à Cames	34
Piston - Connecting rod - Cylinder Kolben - Pleuel - Zylinder Pistón - Biela - Cilindro Piston - Bielle - Cylindre	36
Cylinder head Zylinderkopf Culata Culasse	38
Oil pump - Governor - Governor Bowden Cable Ölpumpe - Regler - Drehzahlverstellung Bomba de aceite - Regulador - Regulador de Revoluciones Cable Bowden Pompe à huile - Régulateur - Bowden	42

Indice**Table des matières**

Command Cover Steuerdeckel Tapa del mando Couvercle de commande	46
Blower-Fly wheel Gebläse - Schwungrad Ventilador-Volante Ventilateur-Volant	50
Injection Equipment Einspritzausrüstung Sistema Inyectora Système d'Injection	52
Rewind Starter Reversierstarter Arrancador Démarreur	58
Air Ducting Luftführung Conducción de Aire Carter Ventilation	60
Crankcase Breathing System Kurbelgehäuseentlüftung Purgado de Cáster Raccord Fileté de Purge	64
Fuel System Kraftstoffsystem Sistema de Combustible Système d'Essence	66
Air Cleaner Luftfilter Filtro del Aire Filtre à Air	72
Exhaust Silencer Abgasdämpfer Silenciador Silencieux	76
Governor Bowden Cable Drehzahlverstellung Bowdenzug Regulador de Revoluciones Cable Bowden Régulateur de Régime Câble	78
Spare Parts Kits Ersatzteilsätze Juegos de Repuestos Jeu de Pièces de Rechange	80
Accessories Zubehör Accesorios Accessoires	83
Urethane Pad Kit cpl. PGV 1850 Gleitvorrichtung kpl. PGV 1850 Placa de Deslizamiento cpl. PGV 1850 Jeu de Tapis en Polyuréthane	84
Handle complete Handgriff kpl. Manija compl. Poignée compl.	86

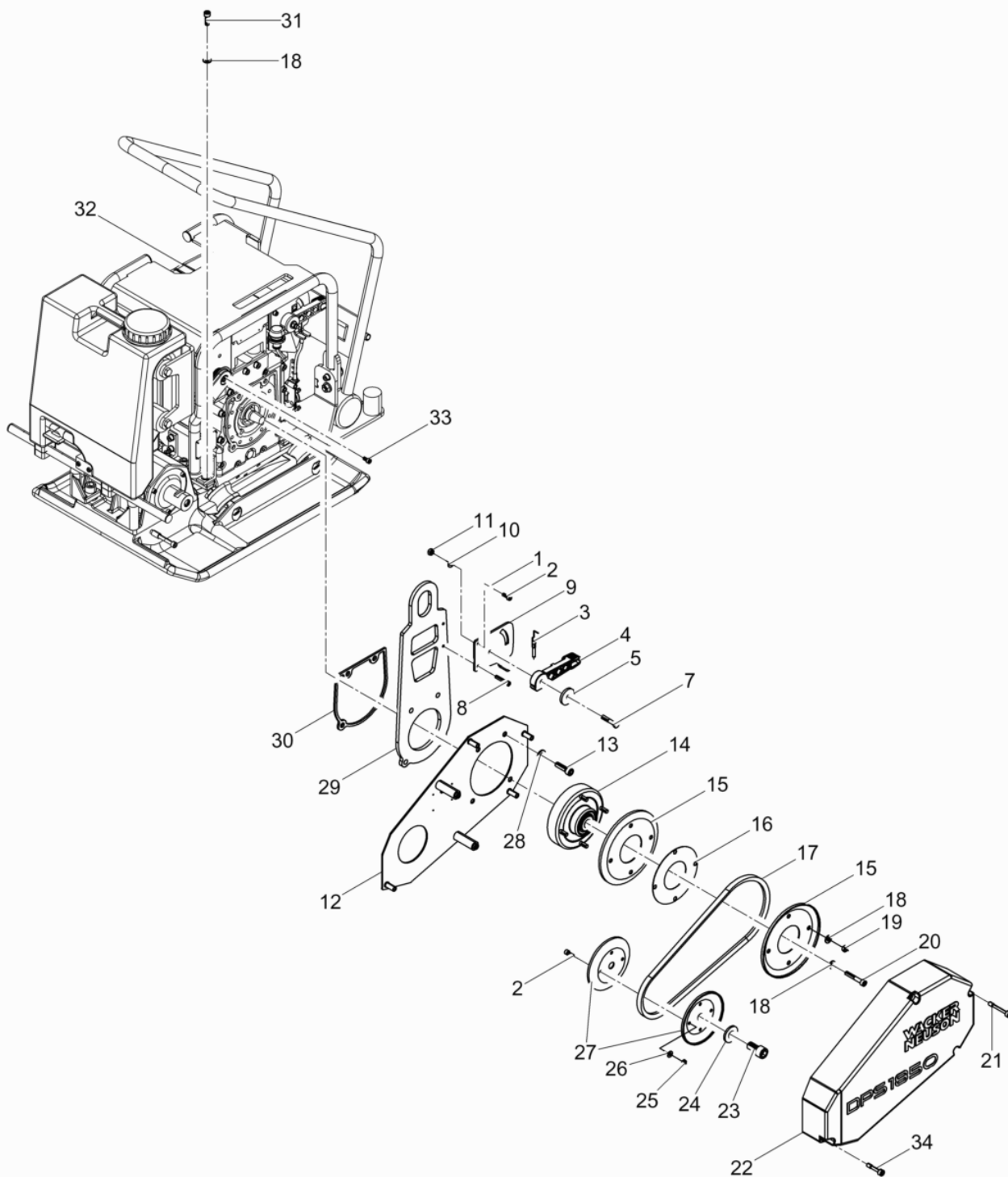

Ref. Pos.	Part No. Artikel Nr.	Qty. St.	Description Beschreibung	Descripción Description	Measurem./Abm.	Norm
					Torque/Drehm.	Sealant Schmierstoff
1	0010624	1	Flat washer Scheibe	Arandela Rondelle		
2	0011553	5	Cheese head screw Zylinderschraube	Tornillo cilíndrico Vis à tête cylindrique	10Nm/7ft.lbs	
3	0125809	1	Bowden cable Bowdenzug	Cable Bowden Câble Bowden		
4	0203537	1	Governor lever Regulierhebel	Palanca reguladora Levier régulateur		
5	0205366	1	Washer Scheibe	Arandela Rondelle		
7	0011341	1	Hexagonal head cap screw Sechskantschraube	Tornillo hexagonal Vis à tête hexagonale	M8 x 40 25Nm/18ft.lbs	DIN931
8	0011548	1	Cheese head screw Zylinderschraube	Tornillo cilíndrico Vis à tête cylindrique	10Nm/7ft.lbs	
9	0125807	1	Bearing Widerlager	Cojinete Roulement		
10	0033198	1	Lockwasher Spannscheibe	Arandela elástica Rondelle de ressort	8	DIN6796
11	0033356	1	Hexagon nut Sechskantmutter	Tuerca hexagonal Écrou hexagonal		
12	0216662	1	Fixing plate cpl. Befestigungsblech kpl.	Chapa de sujeción cpl. Tôle de fixation cpl.		
13	0011533	4	Cheese head screw Zylinderschraube	Tornillo cilíndrico Vis à tête cylindrique	M10 x 35 49Nm/36ft.lbs	ISO4762
14	0108162	1	Centrifugal clutch Fliehkraftkupplung	Embrague centrifugo Embrayage centrifuge		
15	0047280	2	V-belt pulley half Keilriemenscheibenhälfte	Semi-polea en V Flanc de poulie à courroie		
16	0047282	3	Distance washer Distanzscheibe	Distanciador Disque d'écartement	X- 5000084441	
17	0099941	1	Narrow V-belt Schmalkeilriemen	Correa en V angosta Trapezoidale étroite		
18	0033198	9	Lockwasher Spannscheibe	Arandela elástica Rondelle de ressort	8	DIN6796
19	0010882	4	Hexagon nut Sechskantmutter	Tuerca hexagonal Écrou hexagonal		
20	0011537	1	Cheese head screw Zylinderschraube	Tornillo cilíndrico Vis à tête cylindrique	M8 x 50 25Nm/18ft.lbs	ISO4762
21	0216659	3	Screw Dünnschaftschraube	Tornillo Vis	M 8x 55 25Nm/18ft.lbs	
22	0216661	1	Belt guard Riemenschutz	Protección de la polea Protection de courroie		
23	0044634	1	Cheese head screw Zylinderschraube	Tornillo cilíndrico Vis à tête cylindrique	M16 x 30 295Nm/218ft.lbs	ISO4762
24	0043353	1	Lockwasher Spannscheibe	Arandela elástica Rondelle de ressort	16	DIN6796
25	0010880	5	Hexagon nut Sechskantmutter	Tuerca hexagonal Écrou hexagonal		
26	0058381	4	Lockwasher Spannscheibe	Arandela elástica Rondelle de ressort	6	DIN6796

Vibratory Plate cpl.
Vibrationsplatte kpl.
Plancha Vibradora cpl.
Plaque Vibrante cpl.

DPS 1850H
Asphalt

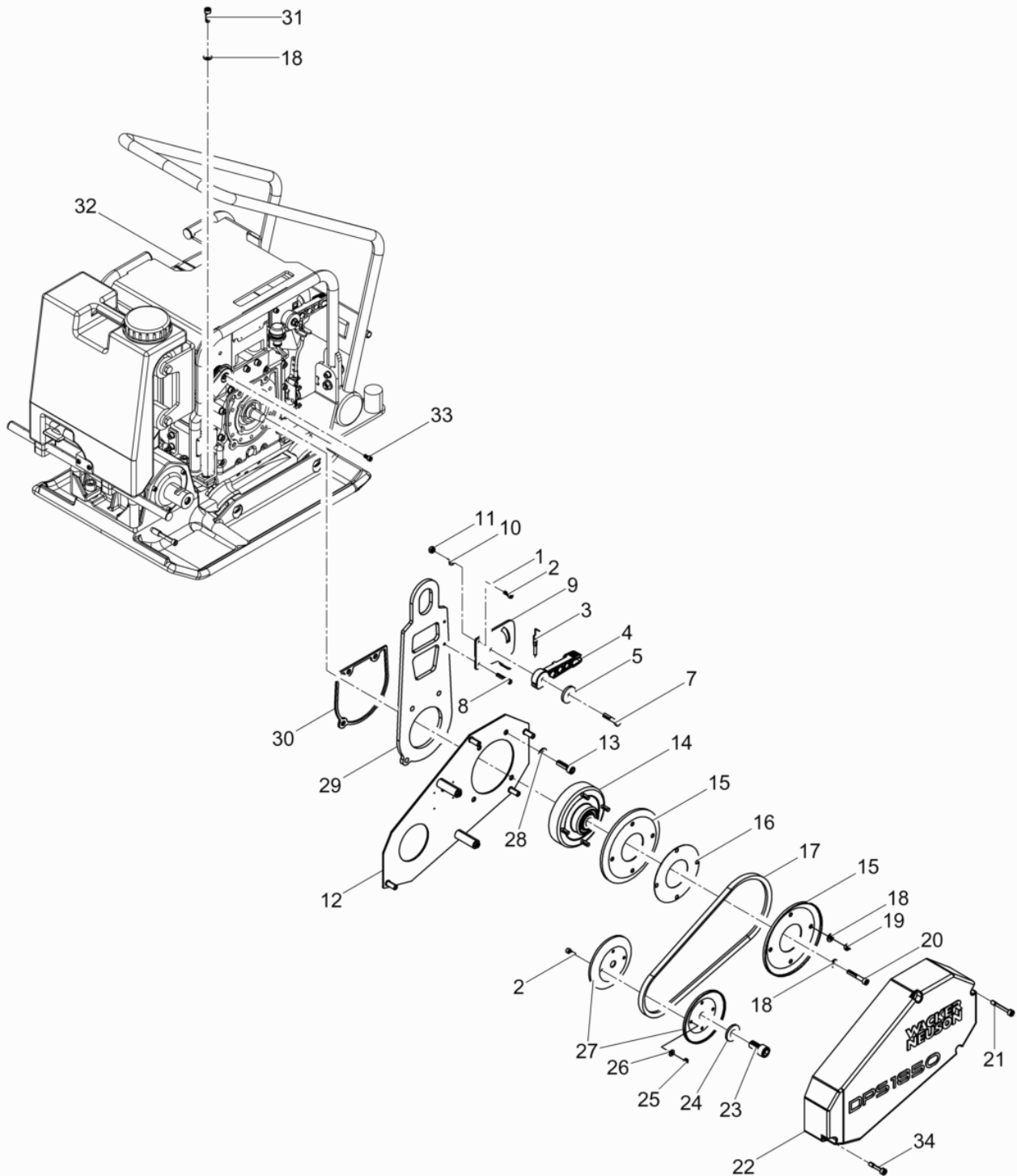

Ref. Pos.	Part No. Artikel Nr.	Qty. St.	Description Beschreibung	Descripción Description	Measurement./Abm.	Norm
					Torque/Drehm.	Sealant Schmierstoff
27	0099828	2	V-belt pulley half Keilriemenscheibenhälfte	Semi-polea en V Flanc de poulie à courroie		
28	0033988	4	Lockwasher Spannscheibe	Arandela elástica Rondelle de ressort	10	DIN6796
29	0201565	1	Lifting point Aufhängung	Punto para itar Suspension		
30	0108275	1	Adaptor Zwischenstück	Pieza intermedia Pièce intermédiaire		
31	0011542	4	Cheese head screw Zylinderschraube	Tornillo cilíndrico Vis à tête cylindrique	25Nm/18ft.lbs	
32	0220359	1	Diesel engine Dieselmotor	Motor diesel Moteur diesel		
33	0011554	1	Cheese head screw Zylinderschraube	Tornillo cilíndrico Vis à tête cylindrique	10Nm/7ft.lbs	
34	0216658	1	Screw Dünnschaftschraube	Tornillo Vis	M 8x 38	

Vibratory Plate cpl.
Vibrationsplatte kpl.
Plancha Vibradora cpl.
Plaque Vibrante cpl.

DPS 1850H
Asphalt

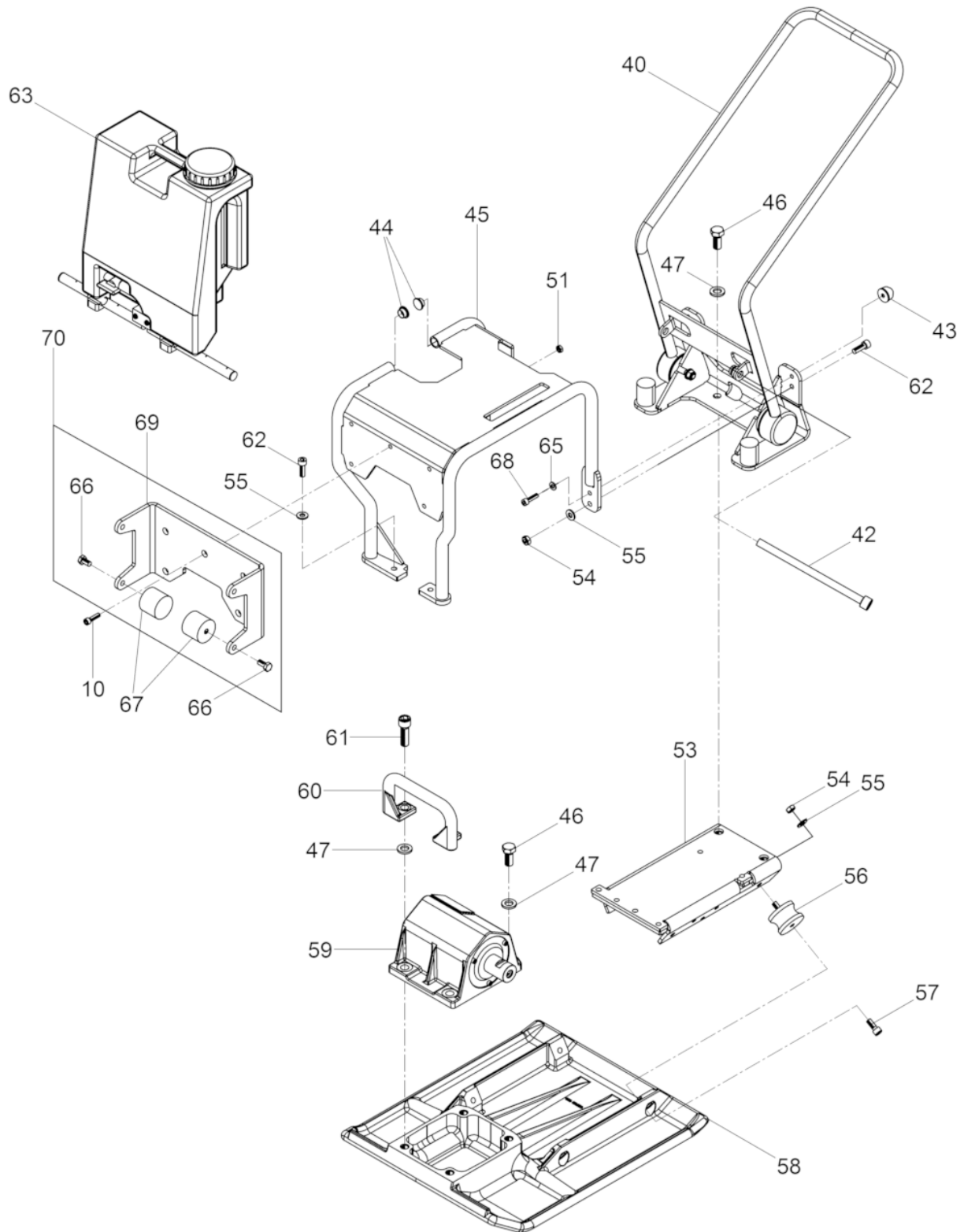

Ref. Pos.	Part No. Artikel Nr.	Qty. St.	Description Beschreibung	Descripción Description	Measurement./Abm.	Norm
					Torque/Drehm.	Sealant Schmierstoff
10	0011542	2	Cheese head screw Zylinderschraube	Tornillo cilíndrico Vis à tête cylindrique	25Nm/18ft.lbs	
40	0215011	1	Center Pole cpl. Deichsel kpl.	Barra de mando cpl. Timon cpl.		
42	0097318	1	Adapter Ablaufstutzen	Empalme Raccord		
43	0105056	2	Shockmount Anschlagpuffer	Amortiguador Silentbloc	M30 x 20	
44	0201891	2	Locking Plug Verschlussstopfen	Tapón de Cierre Bouchon de Fermeture		
45	0201594	1	Protective frame Schutzrahmen	Armazón de protección Cadre protection		
46	0011522	4	Hexagonal head cap screw Sechskantschraube	Tornillo hexagonal Vis à tête hexagonale	M16 x 35 210Nm/155ft.lbs	DIN933
47	0021988	6	Lock washer Sicherungsscheibe	Arandela de seguridad Rondelle d'arrêt	HS16	
51	0010367	5	Hexagon nut Sechskantmutter	Tuerca hexagonal Écrou hexagonal	M8	DIN985
53	0201558	1	Engine Mount Assembly Motorkonsole	Conjunto Soporte de Motor Montage du Moteur		
54	0010883	6	Hexagon nut Sechskantmutter	Tuerca hexagonal Écrou hexagonal		
55	0033988	8	Lockwasher Spannscheibe	Arandela elástica Rondelle de ressort	10	DIN6796
56	0037378	4	Shockmount Gummi-Metall-Kerbpuffer	Tope caucho-metal Tampon métallique oscillant	60 x 40	
57	0011535	4	Cheese head screw Zylinderschraube	Tornillo cilíndrico Vis à tête cylindrique	49Nm/36ft.lbs	
58	0069882	1	Base plate Grundplatte	Placa base Plaque de base		
59	0105405	1	Exciter cpl. Erreger kpl.	Excitador cpl. Vibrateur cpl.		
60	0126072	1	Handle Griff	Empuñadura Poignée		
61	0127056	2	Cheese head screw Zylinderschraube	Tornillo cilíndrico Vis à tête cylindrique	M16 x 50 210Nm/155ft.lbs	ISO4762
62	0011534	4	Cheese head screw Zylinderschraube	Tornillo cilíndrico Vis à tête cylindrique	M10 x 30 49Nm/36ft.lbs	ISO4762
63	0104044	1	Watertank cpl. Wassertank kpl.	Tanque de agua cpl. Reservoir à eau cpl.		
65	0010622	2	Flat washer Scheibe	Arandela Rondelle		
66	0032175	4	Hexagonal head cap screw Sechskantschraube	Tornillo hexagonal Vis à tête hexagonale	M10 x 18 49Nm/36ft.lbs	DIN933
67	0105969	4	Shockmount Anschlagpuffer	Amortiguador Silentbloc		
68	0011541	5	Cheese head screw Zylinderschraube	Tornillo cilíndrico Vis à tête cylindrique	25Nm/18ft.lbs	
69	0201821	1	Fixing device Halterung	Soporte Bague de retenue		

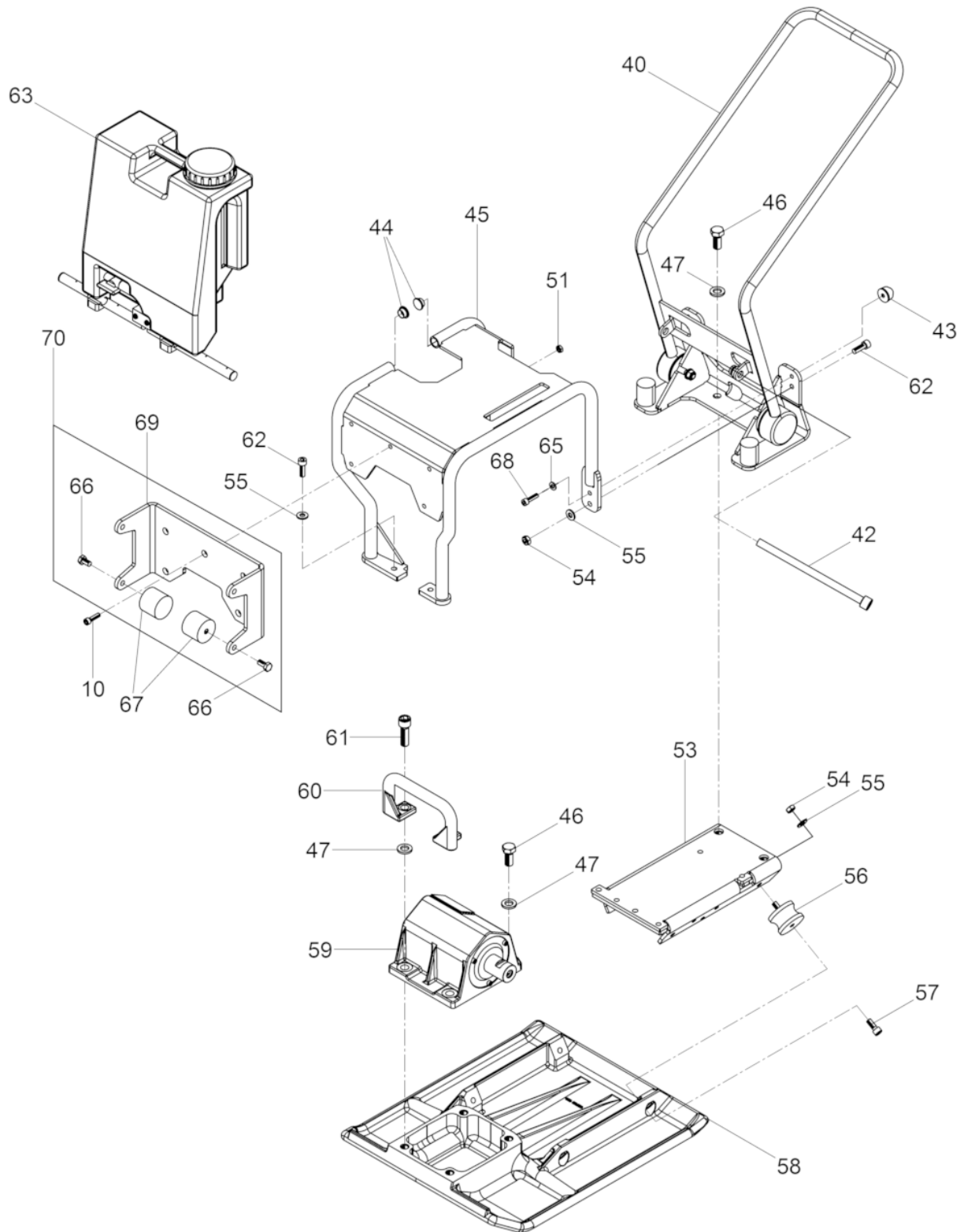

**DPS 1850H
Asphalt**

**Vibratory Plate cpl.
Vibrationsplatte kpl.
Plancha Vibradora cpl.
Plaque Vibrante cpl.**

Ref. Pos.	Part No. Artikel Nr.	Qty. St.	Description Beschreibung	Descripción Description	Measurement./Abm.	Norm
					Torque/Drehm.	Sealant Schmierstoff
70	0106066	1	Fixing device cpl. Halterung kpl.	Soporte cpl. Bague de retenue cpl.		

Exciter cpl.
Erreger kpl.
Excitador cpl.
Excitateur cpl.

DPS 1850H
Asphalt

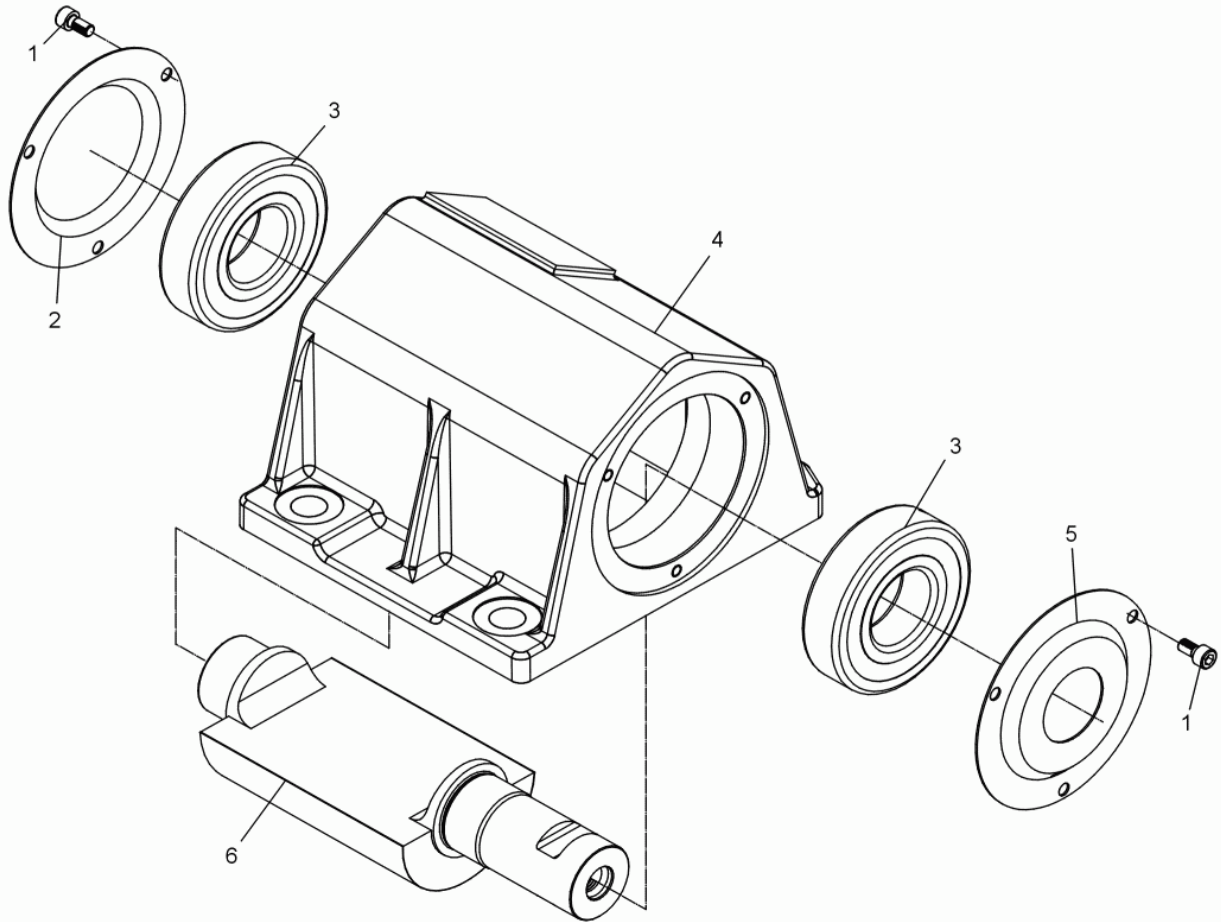

Ref. Pos.	Part No. Artikel Nr.	Qty. St.	Description Beschreibung	Descripción Description	Measurement/Abm.	Norm
					Torque/Drehm.	Sealant Schmierstoff
1	0011554	6	Cheese head screw Zylinderschraube	Tornillo cilíndrico Vis à tête cylindrique	10Nm/7ft.lbs	
2	0099826	1	Cover Deckel	Tapa Couvercle		
3	0099871	2	Grooved ball bearing Rillenkugellager	Rodamiento a bolas Roulement rainuré à billes		
4	0099824	1	Exciter housing Erregergehäuse	Carcasa del excitador Carter exciteur		
5	0099825	1	Cover Deckel	Tapa Couvercle		
6	0105404	1	Eccentric shaft Unwuchtwelle	Eje de la masa excéntrica Arbre portant l'excentrique		

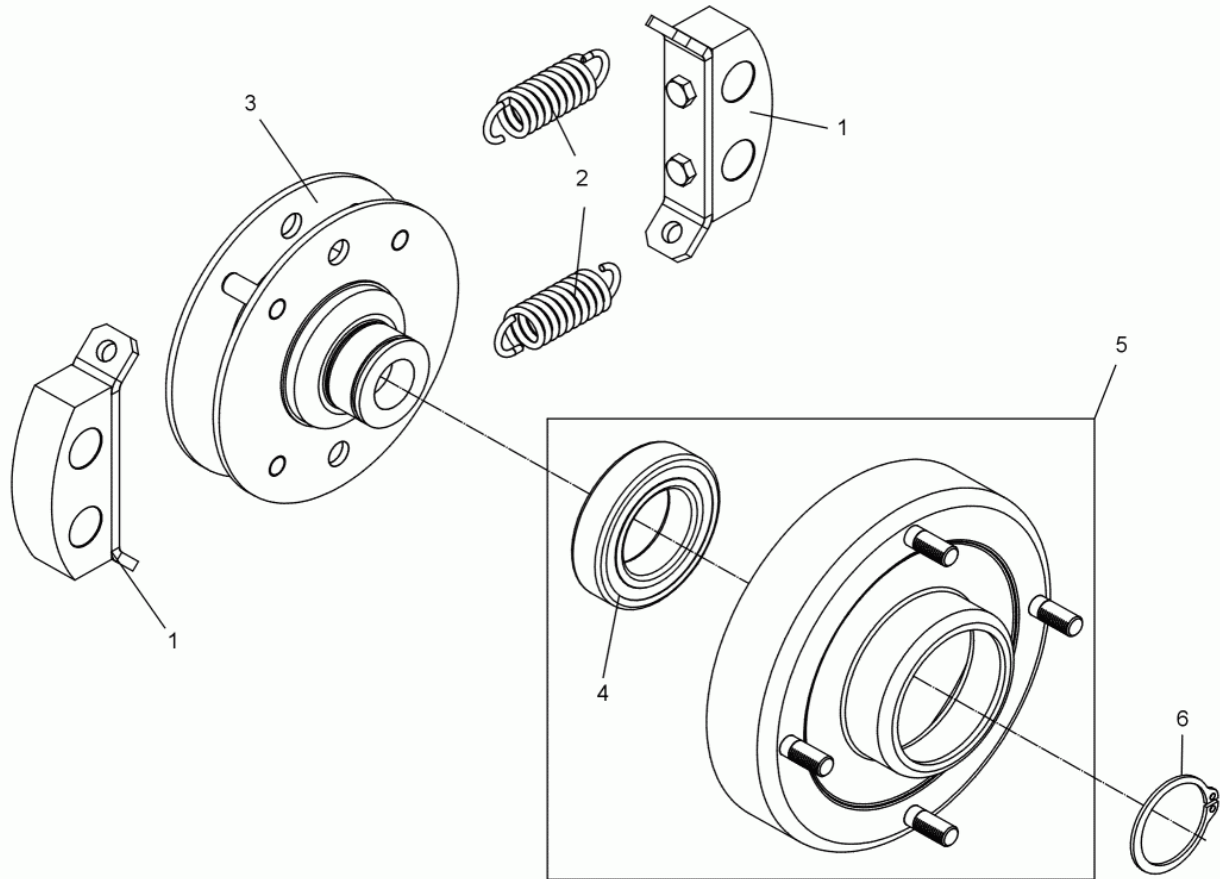

Ref. Pos.	Part No. Artikel Nr.	Qty. St.	Description Beschreibung	Descripción Description	Measurement./Abm.	Norm
					Torque/Drehm.	Sealant Schmierstoff
1	0045716	2	Friction block cpl. Reibklotz kpl.	Taco frotante cpl. Bloc frottant cpl.		
2	0058765	2	Tension spring Zugfeder	Resorte de tracción Ressort de traction		
3	0108161	1	Hub cpl. Nabe kpl.	Cubo cpl. Moyeu cpl.		
4	0022625	1	Grooved ball bearing Rillenkugellager	Rodamiento a bolas Roulement rainuré à billes		
5	0106622	1	Drum cpl. Trommel kpl.	Tambor cpl. Tambour cpl.		
6	2003022	1	Retaining ring Sicherungsring	Anillo de retención Bague d'arrêt	35 x 1,5	DIN471

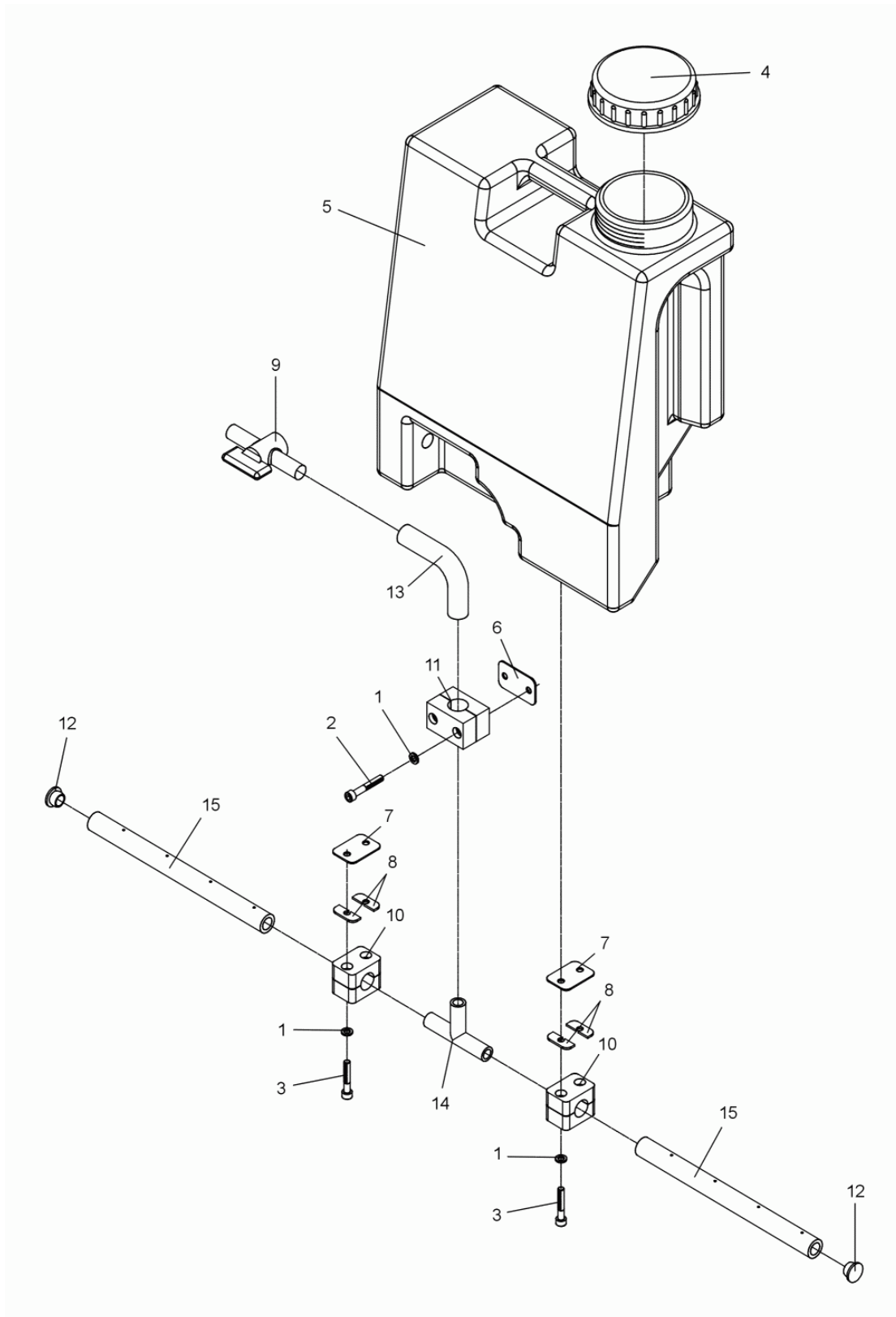

Ref. Pos.	Part No. Artikel Nr.	Qty. St.	Description Beschreibung	Descripción Description	Measurement/Abm.	Norm
					Torque/Drehm.	Sealant Schmierstoff
1	0010744	6	Washer Scheibe	Arandela Rondelle	6,4	DIN433
2	0011547	2	Cheese head screw Zylinderschraube	Tornillo cilíndrico Vis à tête cylindrique	10Nm/7ft.lbs	
3	0011548	4	Cheese head screw Zylinderschraube	Tornillo cilíndrico Vis à tête cylindrique	10Nm/7ft.lbs	
4	0068351	1	Screwed cover Schraubdeckel	Tapa roscable Couvercle fileté		
5	0102864	1	Watertank Wassertank	Tanque de agua Reservoir à eau		
6	5000103545	1	Bar Leiste	Listón Listeau		
7	5000103546	2	Bar Leiste	Listón Listeau		
8	5000103548	4	Distance plate Distanzplatte	Placa distanciador Plaque d'écartement		
9	0103550	1	Angular tap Durchlaufhahn	Grifo angular Robinet angulaire		
10	0103551	2	Standard clamp Stauff-Standardschelle	Abrazadera standard Collier standard		
11	0103552	1	Standard clamp Stauff-Standardschelle	Abrazadera standard Collier standard		
12	0103553	2	Locking plug Verschlußstopfen	Tapón de cierre Bouchon de fermeture		
13	0103986	1	Hose Schlauch	Manguera Tuyau		
14	0104041	1	T-piece T-Stück	Pieza T T-pièce		
15	0104043	2	Jet tube Düsenrohr	Tube a gicleur Tube à gicleur		

Center Pole cpl.
Deichsel kpl.
Barra de mando cpl.
Timon cpl.

DPS 1850H
Asphalt

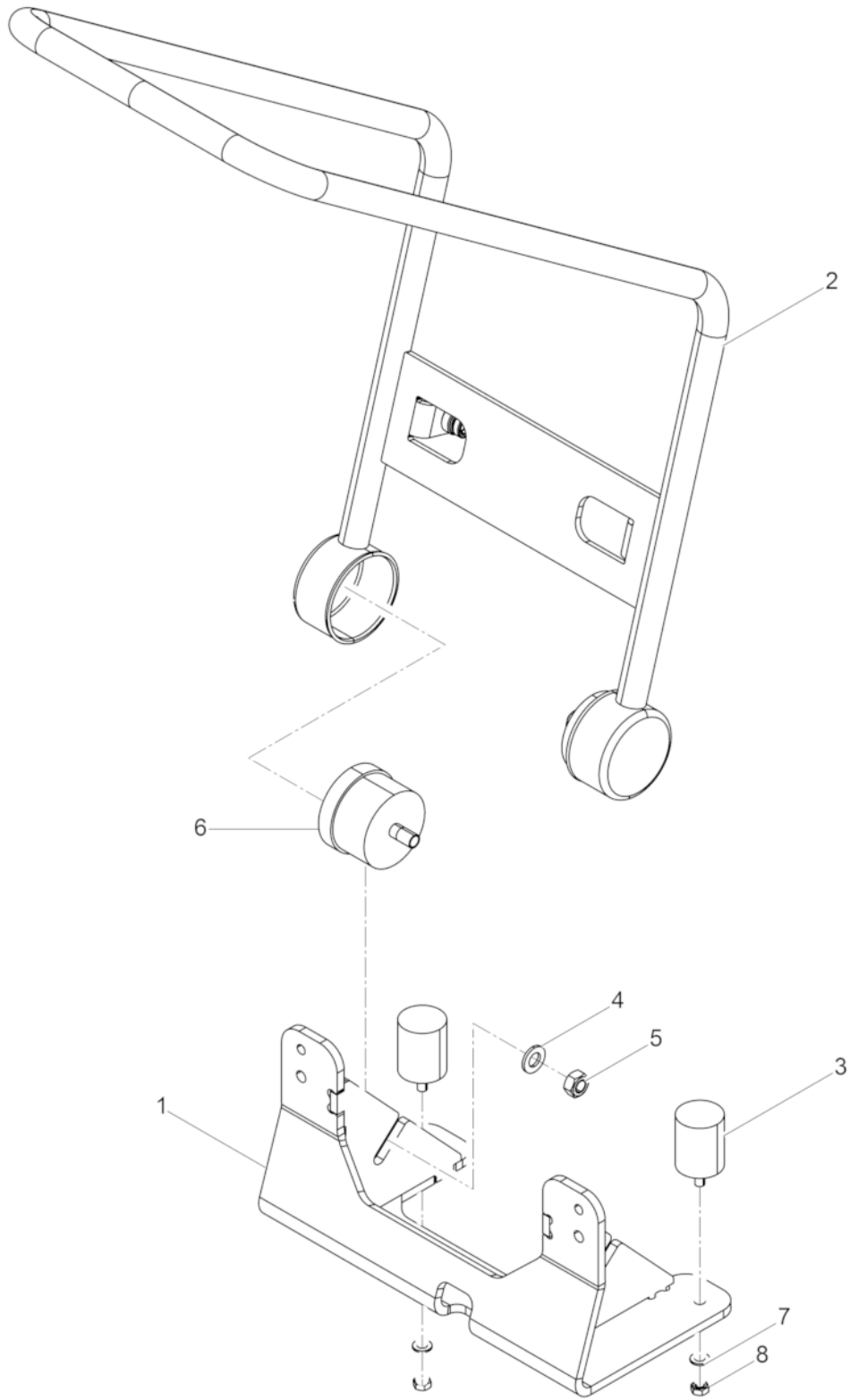

Ref. Pos.	Part No. Artikel Nr.	Qty. St.	Description Beschreibung	Descripción Description	Measurement/Abm.	Norm
					Torque/Drehm.	Sealant Schmierstoff
1	0202879	1	Center Pole Console Deichselkonsole	Consola de Barra de Mando Console de Timon		
2	0212142	1	Clamp Bügel	Abrazadera Attache		
3	0215030	2	Shockmount Puffer	Amortiguador Silentbloc		
4	0010622	2	Flat washer Scheibe	Arandela Rondelle		
5	0010882	2	Hexagon nut Sechskantmutter	Tuerca hexagonal Écrou hexagonal		
6	0106557	2	Shockmount Gummi-Metall-Puffer	Tope caucho-metal Tampon métallique oscillant		
7	0010620	2	Flat washer Scheibe	Arandela Rondelle	12	ISO7090
8	0010884	2	Hexagon nut Sechskantmutter	Tuerca hexagonal Écrou hexagonal	M12	DIN934

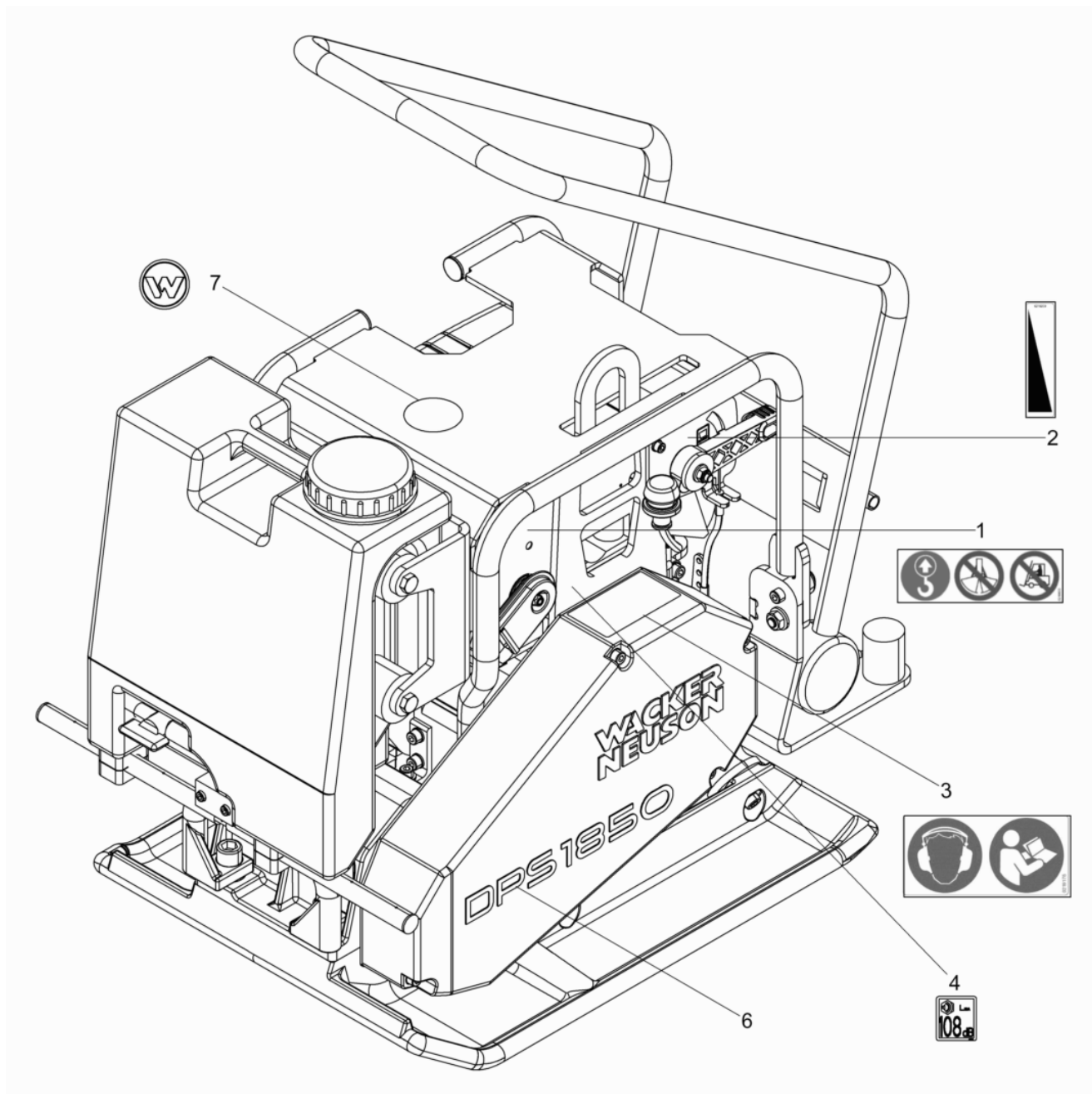

Ref. Pos.	Part No. Artikel Nr.	Qty. St.	Description Beschreibung	Descripción Description	Measurement/Abm.	Norm
					Torque/Drehm.	Sealant Schmierstoff
1	0216633	1	Instruction Label Aufkleber-Hinweis	Calcomanía-Indicación Autocollant avec Indication		
2	0219259	1	Labels Aufkleber	Calcomanias Autocollants		
3	0219175	1	Labels Aufkleber	Calcomanias Autocollants		
4	0129784	1	Decal-Sound Power Level Aufkleber-Schallleistungspegel	Etiqueta autoadhesiva-nivel de potencia acúeëstica Autocollante-niveau sonore		
6	0108285	1	Type Label Aufkleber-Typ	Tipo etiqueta autoadhesiva Autocollant de type		
7	0222085	1	Label Symbol Aufkleber Symbol	Calcomania Símbolo Autocollant Symbole		



**WACKER
NEUSON**

**Engine
Motor
Motor
Moteur**

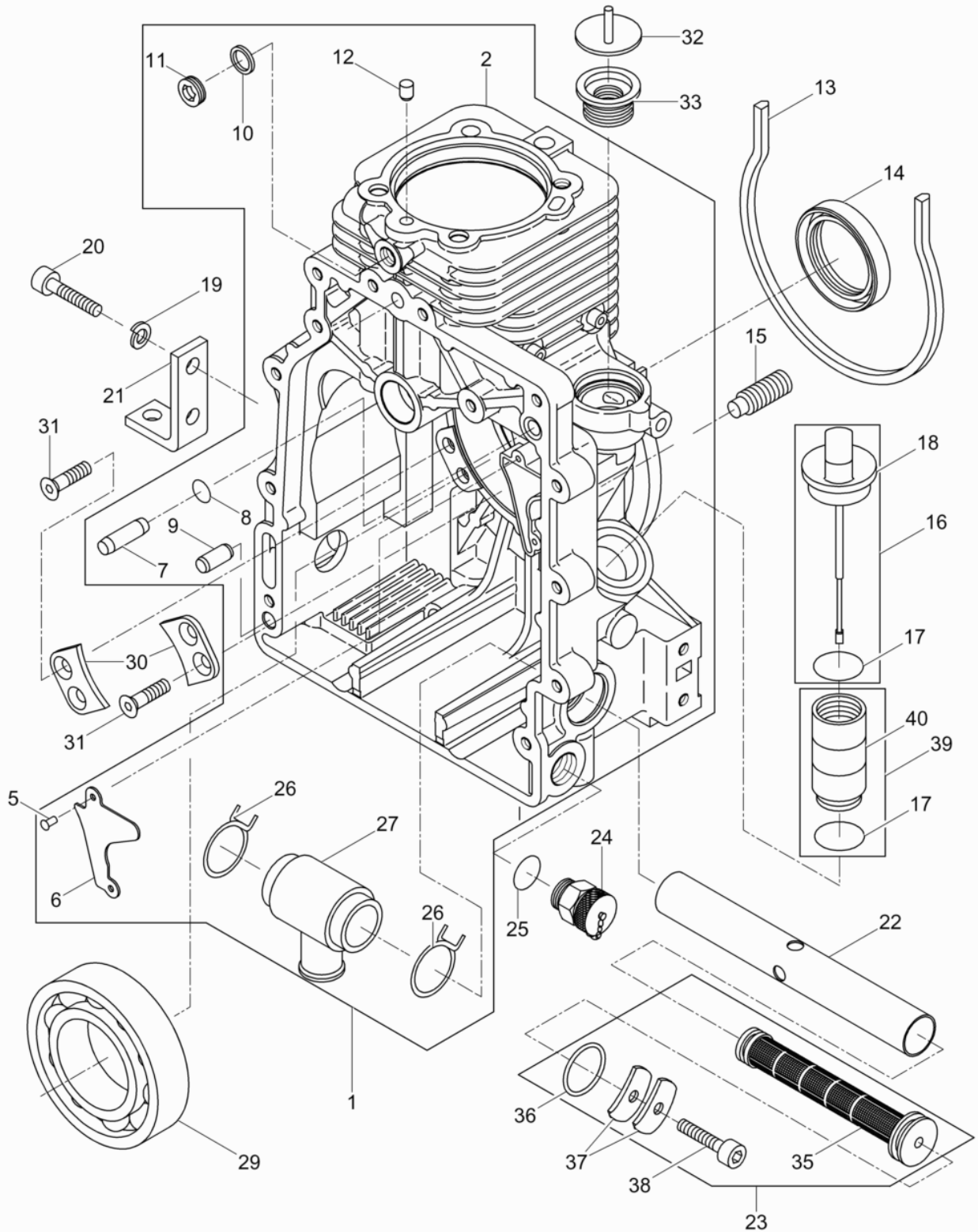

Ref. Pos.	Part No. Artikel Nr.	Qty. St.	Description Beschreibung	Descripción Description	Measurement./Abm.	Norm
					Torque/Drehm.	Sealant Schmierstoff
1	0129029	1	Crankcase Kurbelgehäuse	Cárter Carter		
5	0151209	2	Blind rivet Blindniet	Remache ciego Rivet dobturation	3,2	
6	0129506	1	Cover plate Abdeckblech	Cubierta de chapa Tôle de recouvrement		
7	0128964	1	Straight pin Zylinderstift	Pasador cilíndrico Goupille cylindrique	8m 6x24	
8	0108696	1	O-Ring O-Ring	Anillo-O Joint torique	8 x 1,5	
9	0207615	1	Straight pin Zylinderstift	Pasador cilíndrico Goupille cylindrique	8x20	
10	0071121	1	Sealing ring Dichtungsring	Anillo sellante Bague d'étanchéité	A10 x 13,5	
11	0151213	1	Screw plug Verschlußschraube	Tornillo de cierre Vis de fermeture	M10 X 1	DIN908
13	0108678	1	Seal Dichtungsprofil	Empaque Joint	315	
14	0108679	1	Oil seal Wellendichtring	Empaque de aceite Joint d'huile	40 x 55 x 10	
15	0108680	1	Screw Gewindestift	Tornillo Vis		
16	0128995	1	Dipstick Tauchstab	Varilla de Inmersión Jauge		
17	0151217	1	Gasket Wellendichtring	Anillo de sellado Anneau d'étanchéité	26x35x3	
19	0151218	8	Lock washer Federring	Arandela elástica Rondelle de ressort	8	
20	0108683	8	Screw Schraube	Tornillo Vis	M8 x 35	
21	0108682	4	Bracket Motorfuß	Soporte Support		
22	0151221	1	Housing Ölfiltergehäuse	Caja Carter		
23	0108685	1	Oil filter Ölfilter	Filtro de aceite Filtre d'huile		
24	0128998	1	Oil drain valve Ölablassventil	Válvula de purgado Soupape découlement d'huile		
25	0202416	1	Oil Seal Öldichtung	Junta de Aceite Joint D'Huile	52 x 80 x 10	
26	0108688	2	Clip Schlauchklemme	Sujetador Agrafe		
27	0108691	1	Suction port Ansauggehäuse	Lumbrera Port		
29	0108690	1	Bearing Lager	Rodamiento Roulement	6308	
30	0108692	2	Plate Halter	Placa Plaque		
31	0209740	4	Countersunk screw Senkkopfschraube	Tornillo avellanado Vis noyée	M6x16	

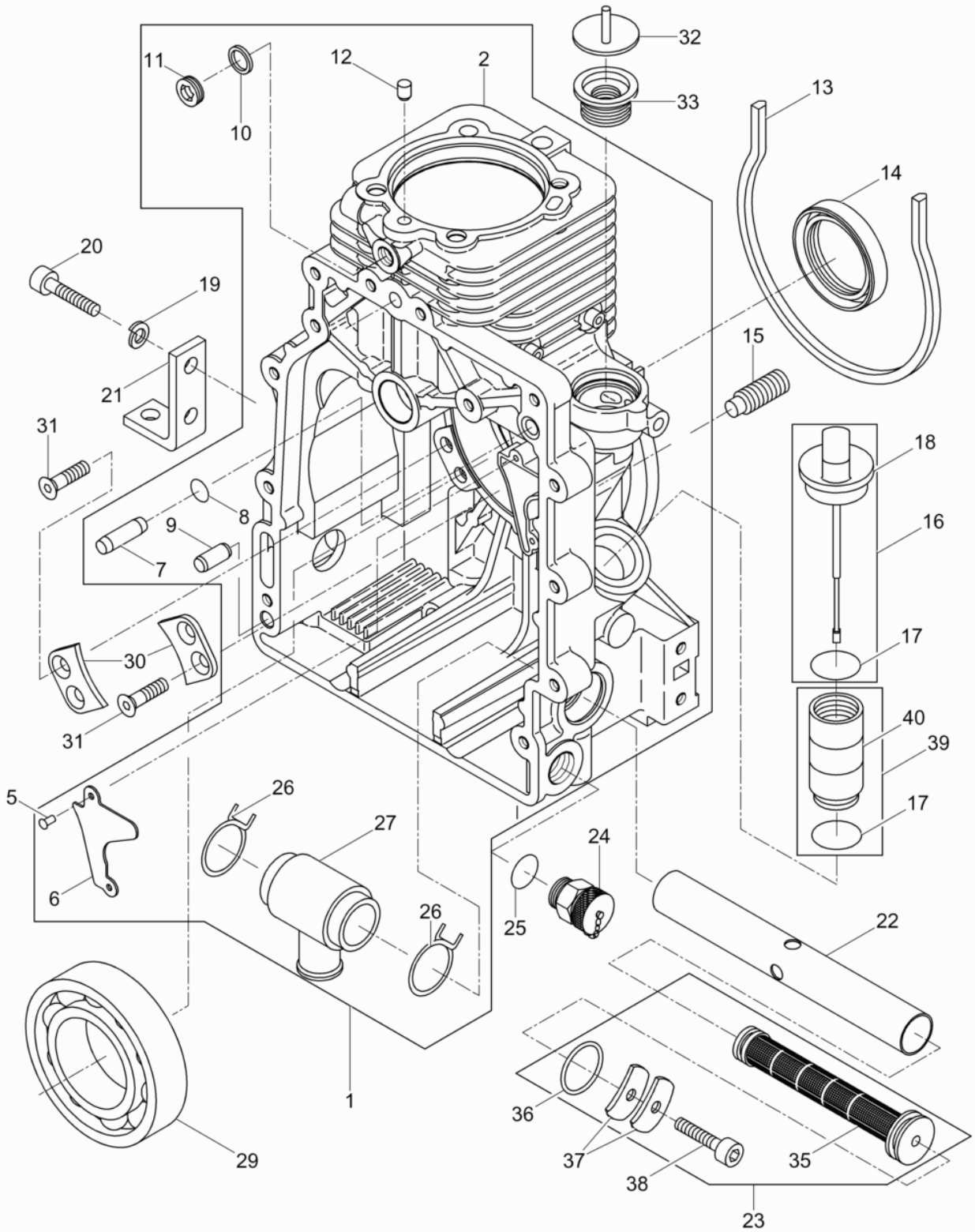

Ref. Pos.	Part No. Artikel Nr.	Qty. St.	Description Beschreibung	Descripción Description	Measurement./Abm.	Norm
					Torque/Drehm.	Sealant Schmierstoff
32	0108676	1	Washer Scheibe	Arandela Rondelle		
33	0094884	1	Diaphragm Membrane	Diafragma Diaphragme		
36	0151229	1	O-Ring O-Ring	Anillo-O Joint torique	20 x 4	
37	0151230	2	Oil Filter Spring Ölfilterfeder	Resorte de Filtro de Aceite Clavette Filtre à Huile		
38	0151231	1	Cheese head screw Zylinderschraube	Tornillo cilíndrico Vis à tête cylindrique	M6 x 16	ISO4762
39	0151231	1	Cheese head screw Zylinderschraube	Tornillo cilíndrico Vis à tête cylindrique	M6 x 16	ISO4762

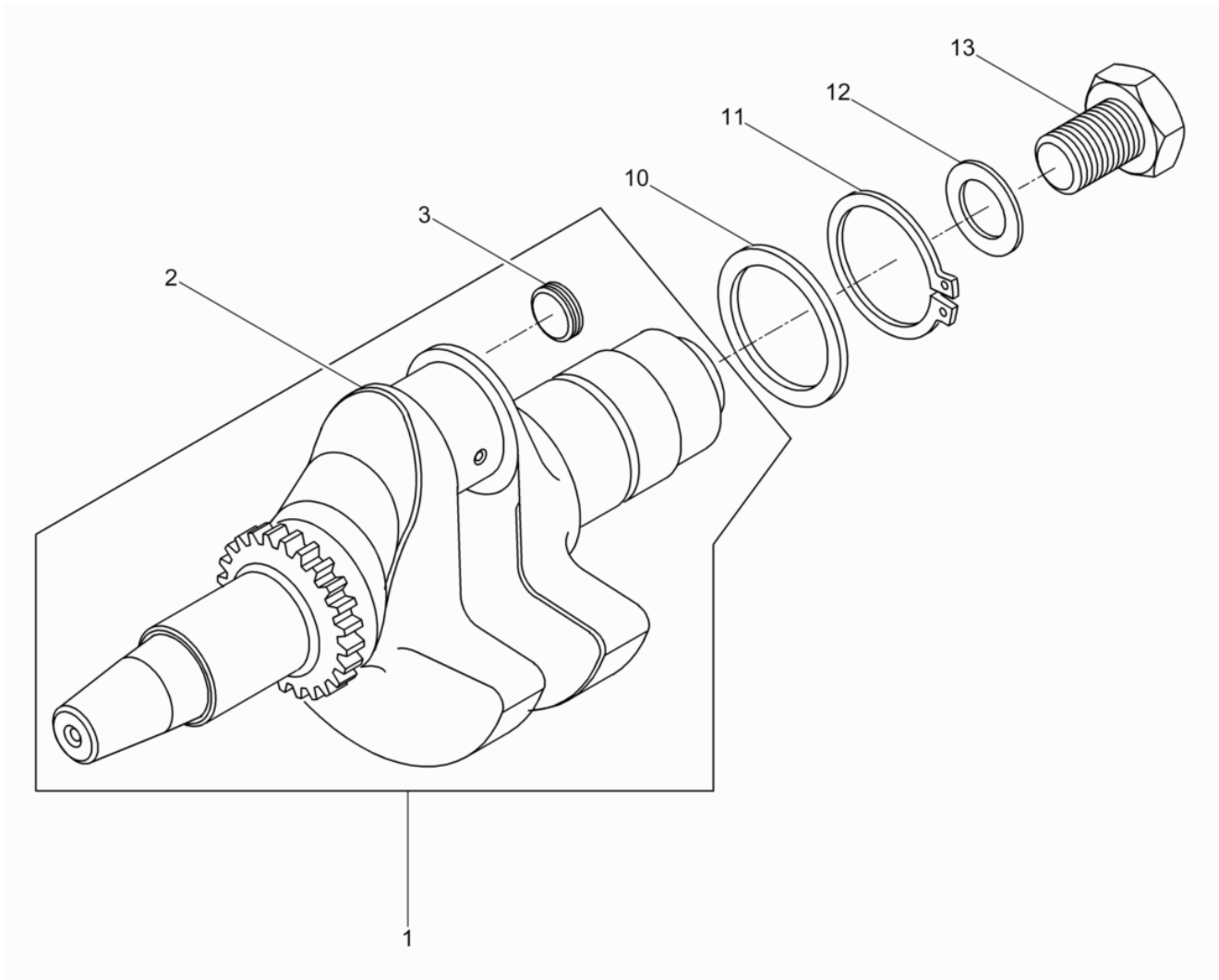

Ref. Pos.	Part No. Artikel Nr.	Qty. St.	Description Beschreibung	Descripción Description	Measurement./Abm.	Norm
					Torque/Drehm.	Sealant Schmierstoff
1	0215771	1	Crankshaft Kurbelwelle	Cigüeñal Vilebrequin		
3	0151233	1	Push-in plug Verschlußstopfen	Tapón Bouchon	12	
10	0108714	1	Supporting Washer Stützscheibe	Arandela de Soporte Disque D'Appui		
11	0129514	1	Retaining ring Sicherungsring	Anillo de retención Bague d'arrêt	40 x 1,75	
12	0108715	1	Disc Scheibe	Disco Disque	18,5 x 37 x 5	
13	0108716	1	Hexagonal head cap screw Sechskantschraube	Tornillo hexagonal Vis à tête hexagonale	M18 x 1 290Nm/214ft.lbs	

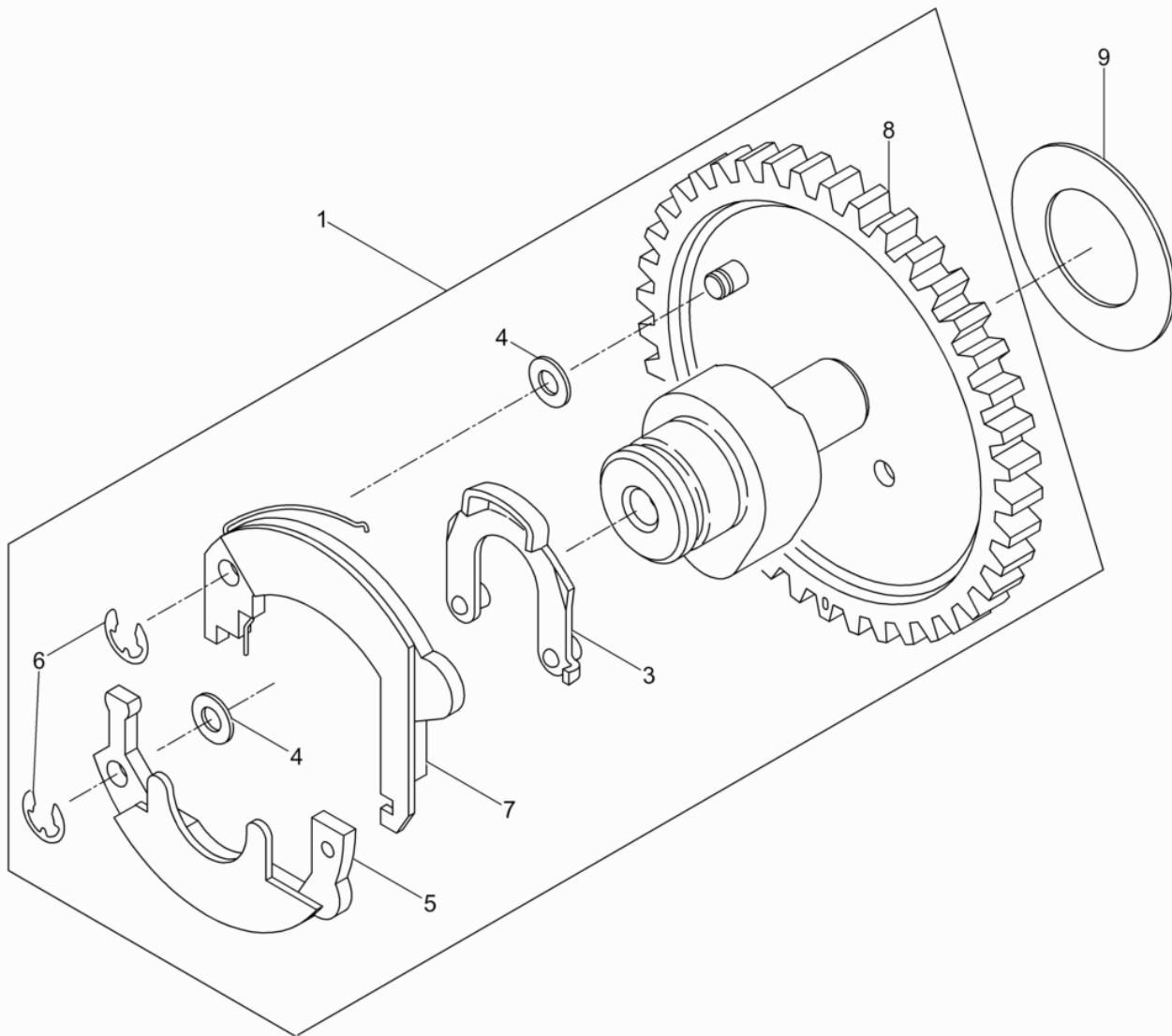

Ref. Pos.	Part No. Artikel Nr.	Qty. St.	Description Beschreibung	Descripción Description	Measurement./Abm.	Norm
					Torque/Drehm.	Sealant Schmierstoff
1	0151248	1	Camshaft Nockenwelle	Arbol de levas Arbre à cames		
3	0108707	1	Lever Bügel	Palanca Levier		
4	0108700	2	Shim Ring Passscheibe	Arandela de Ajuste Disque D'Ajustage	5 x 10 x 0,5	DIN988
5	0108709	1	Weight Fliehwicht	Peso Poids		
6	0151253	2	Lock washer Sicherungsscheibe	Arandela de seguridad Rondelle d'arrêt	3,2	DIN6799
7	0151254	1	Centrifugal weight Fliehwicht	Peso centrífugo Poids centrifuge		
9	0108701	1	Shim ring Passscheibe	Arandela de ajuste Disque dajustage	0,9	
9	0108702	1	Shim Ausgleichsscheibe	Laminilla Cale	1,0	
9	0108703	1	Shim Ausgleichsscheibe	Laminilla Cale	1,1	
9	0108704	1	Shim Ausgleichsscheibe	Laminilla Cale	1,2	
9	0108705	1	Shim ring Passscheibe	Arandela de ajuste Disque dajustage	1,3	
9	0108706	1	Shim ring Passscheibe	Arandela de ajuste Disque dajustage	1,4	

Piston - Connecting rod - Cylinder
Kolben - Pleuel - Zylinder
Pistón - Biela - Cilindro
Piston - Bielle - Cylindre

DPS 1850H
Asphalt

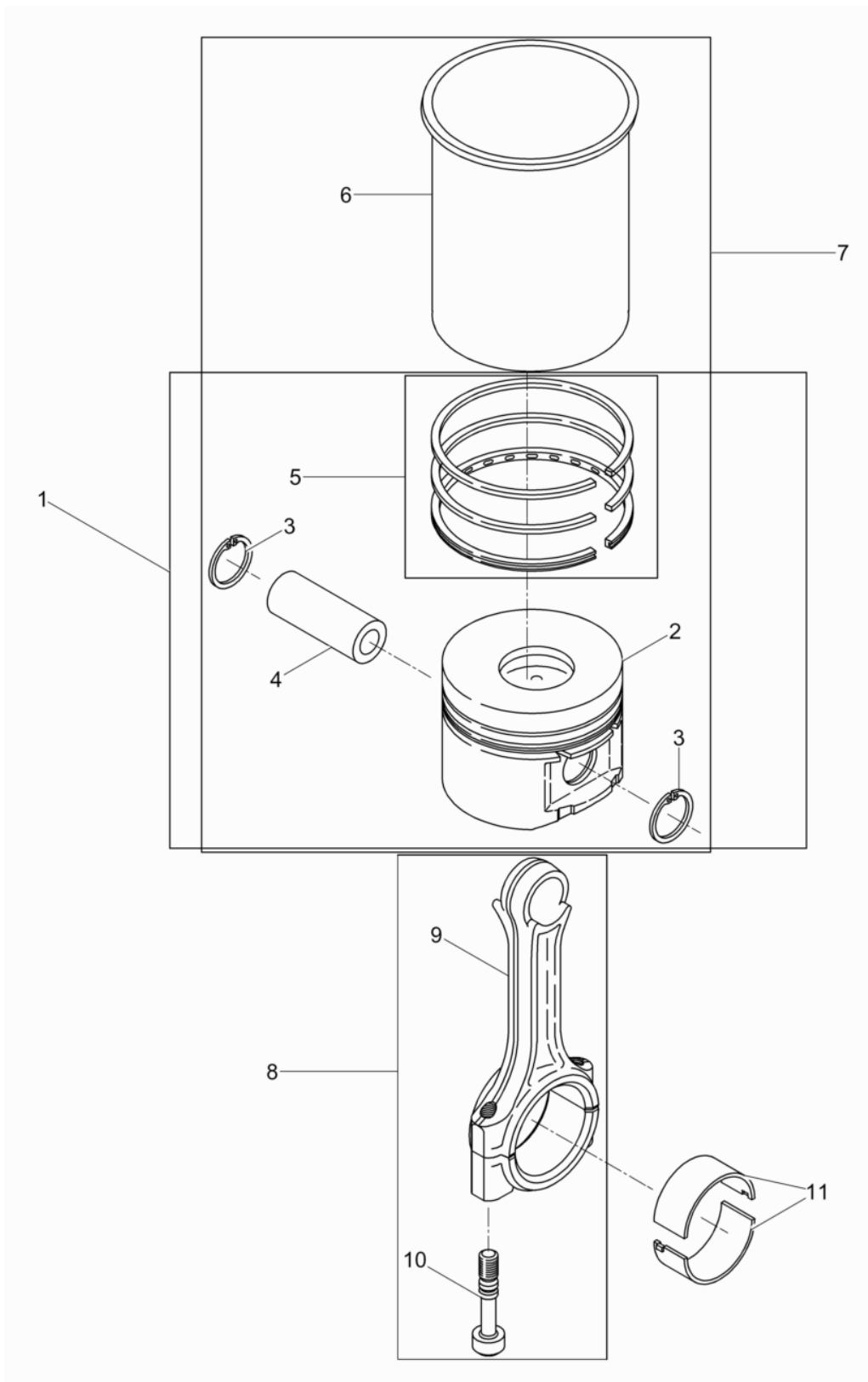

Ref. Pos.	Part No. Artikel Nr.	Qty. St.	Description Beschreibung	Descripción Description	Measurement./Abm.	Norm
					Torque/Drehm.	Sealant Schmierstoff
1	0215769	1	Piston cpl. Kolben kpl.	Pistón cpl. Piston cpl.		
3	0108722	2	Retaining ring Sicherungsring	Anillo de retención Bague d'arrêt	18 x 1	DIN472
5	0129030	1	Set of piston rings Kolbenringsatz	Juego de aros de pistón Jeu de segments de piston	ø69 x 1,5	
7	0215772	1	Cylinder with piston Zylinder mit Kolben	Cilindro con pistón Cylindre avec piston		
8	0108719	1	Connecting rod Pleuel	Biela Bielle		
10	0108720	2	Screw Pleuelschraube	Tornillo Vis		
11	0108717	1	Bearing Pleuellager	Rodamiento Roulement		
11	0108718	1	Bearing Pleuellager	Rodamiento Roulement	-0,5	

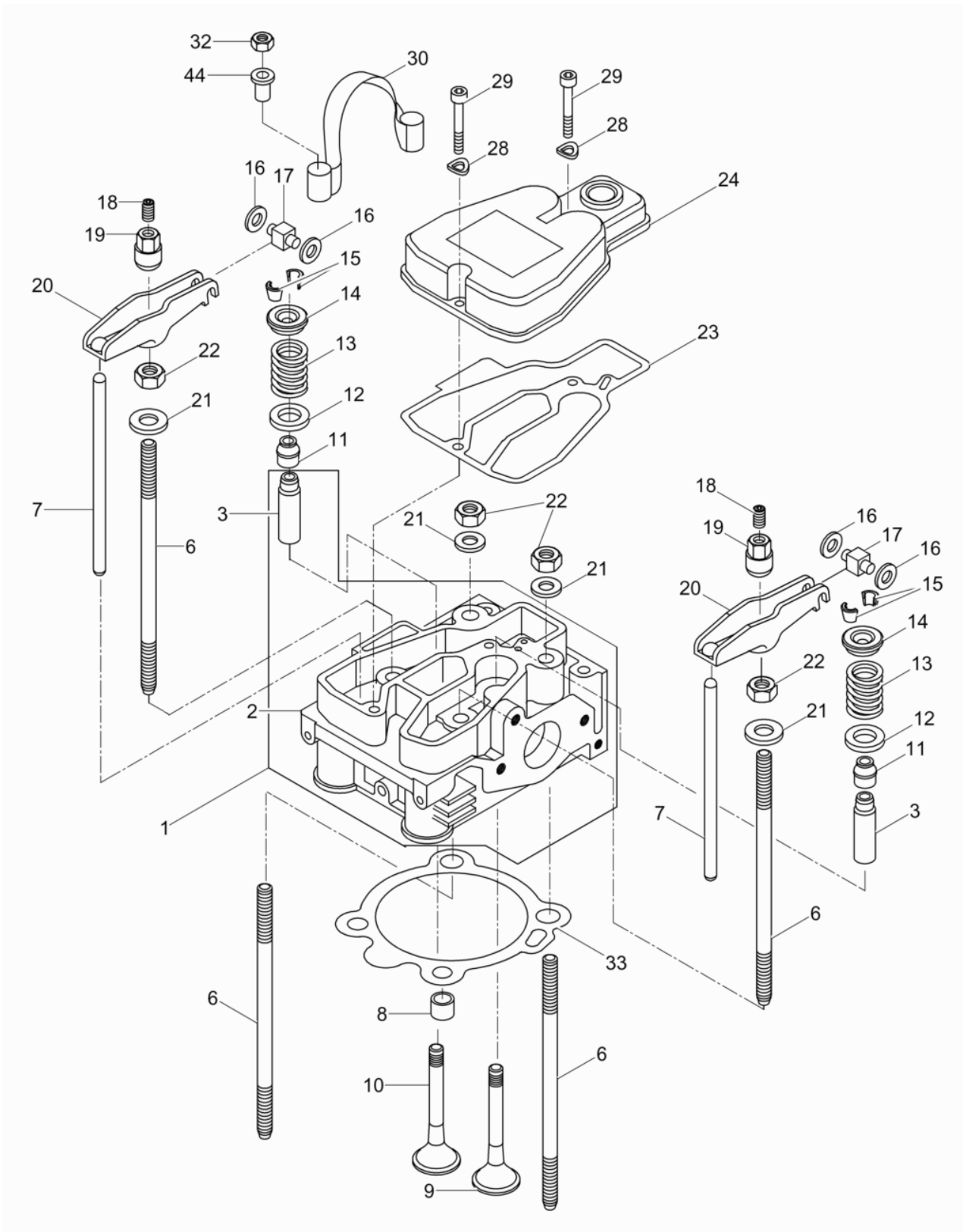

Ref. Pos.	Part No. Artikel Nr.	Qty. St.	Description Beschreibung	Descripción Description	Measurement/Abm.	Norm
					Torque/Drehm.	Sealant Schmierstoff
1	0215770	1	Cylinder head Zylinderkopf	Tapa del cilindro Culasse		
3	0129000	2	Valve guide Ventilführung	Guía de válvula Guide de soupape		
6	0108740	4	Stud Stiftschraube	Perno prisionero Boulon	128M	
7	0108741	2	Push rod (valve lifter) Stoßstange	Levantaválvula Poussoir de soupape		
8	0108752	2	Gasket Dichtring	Anillo de junta Bague détanchéité		
9	0108750	1	Intake valve Einlassventil	Válvula de admisión Soupape d'admission		
10	0108751	1	Exhaust valve Auslaßventil	Válvula de escape Soupape d'échappement		
11	0108738	2	Cap Dichtkappe	Tapa Couvercle		
12	0108737	2	Washer Scheibe	Arandela Rondelle		
13	0108736	2	Spring Ventilfeder	Resorte Ressort		
14	0108735	2	Plate Federteller	Placa Plaque		
15	0108734	2	Spring holder Ventilkonussatz	Soporte Support		
16	0202301	4	Washer Scheibe	Arandela Rondelle	6 x 12 x 1,35	
16	0108730	4	Disc Scheibe	Disco Disque	6 x 12 x 1.2	
17	0108731	2	Slider Rolle	Manguito Douille		
18	0129001	2	Threaded pin Gewindestift	Varilla roscada Goupille fileté	M8 x 10	DIN916
19	0108732	2	Nut Einstellmutter	Tuerca Ecrou		
20	0226320	2	Rocker arm Kiphebel	Balancín Culbuteur		
21	0108739	4	Washer Scheibe	Arandela Rondelle	8,1 x 20 x 3	
22	0094876	4	Hexagon nut Sechskantmutter	Tuerca hexagonal Écrou hexagonal	M8	ISO4032
23	0108729	1	Seal Dichtung	Junta Joint		
24	0209708	1	Cover Zylinderkopfdeckel	Tapa Couvercle		
28	0151290	2	Spring washer Federscheibe	Arandela elástica Rondelle à ressort	A6	DIN137
29	0129002	2	Cheese head screw Zylinderschraube	Tornillo cilíndricoatado Vis à tête cylindrique	M6 x 35	ISO4762
30	0209694	1	Engine Mount Motoraufhängung	Montaje del Motor Montage du Moteur		

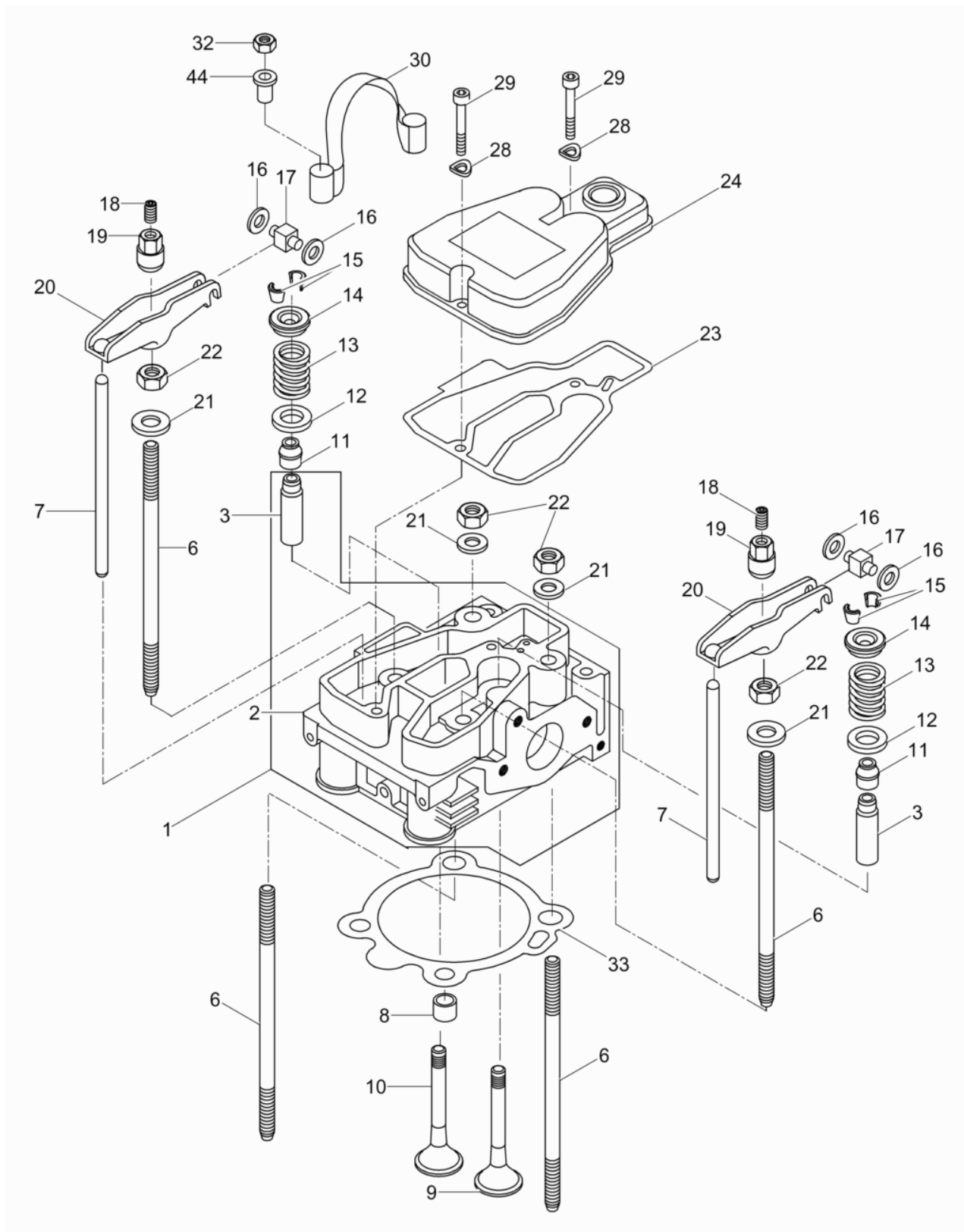

Ref. Pos.	Part No. Artikel Nr.	Qty. St.	Description Beschreibung	Descripción Description	Measurem./Abm.	Norm
					Torque/Drehm.	Sealant Schmierstoff
32	0129516	2	Nut Mutter	Tuerca Ecrou	M8	
33	0209700	1	Cylinder head gasket Zylinderkopfdichtung	Junta de culata del cilindro Joint de culasse de cylindre	0,35	
33	0108742	1	Gasket Dichtung	Junta Joint	0,3	
33	0108743	1	Gasket Dichtung	Junta Joint	0,4	
33	0108744	1	Gasket Dichtung	Junta Joint	0,5	
33	0108745	1	Gasket Dichtung	Junta Joint	0,6	
33	0108746	1	Gasket Dichtung	Junta Joint	0,7	
33	0108747	1	Gasket Dichtung	Junta Joint	0,8	
33	0108748	1	Gasket Dichtung	Junta Joint	0,9	
33	0108749	1	Gasket Dichtung	Junta Joint	1,0	
33	0209701	1	Cylinder head gasket Zylinderkopfdichtung	Junta de culata del cilindro Joint de culasse de cylindre	0,45	
33	0209702	1	Cylinder head gasket Zylinderkopfdichtung	Junta de culata del cilindro Joint de culasse de cylindre	0,55	
33	0209703	1	Cylinder head gasket Zylinderkopfdichtung	Junta de culata del cilindro Joint de culasse de cylindre	0,65	
33	0209704	1	Cylinder head gasket Zylinderkopfdichtung	Junta de culata del cilindro Joint de culasse de cylindre	0,75	
33	0209705	1	Cylinder head gasket Zylinderkopfdichtung	Junta de culata del cilindro Joint de culasse de cylindre	0,85	
33	0209706	1	Cylinder head gasket Zylinderkopfdichtung	Junta de culata del cilindro Joint de culasse de cylindre	0,95	
44	0209736	2	Insert Rohrniet	Inserto Insertion	A10x0,75x10	

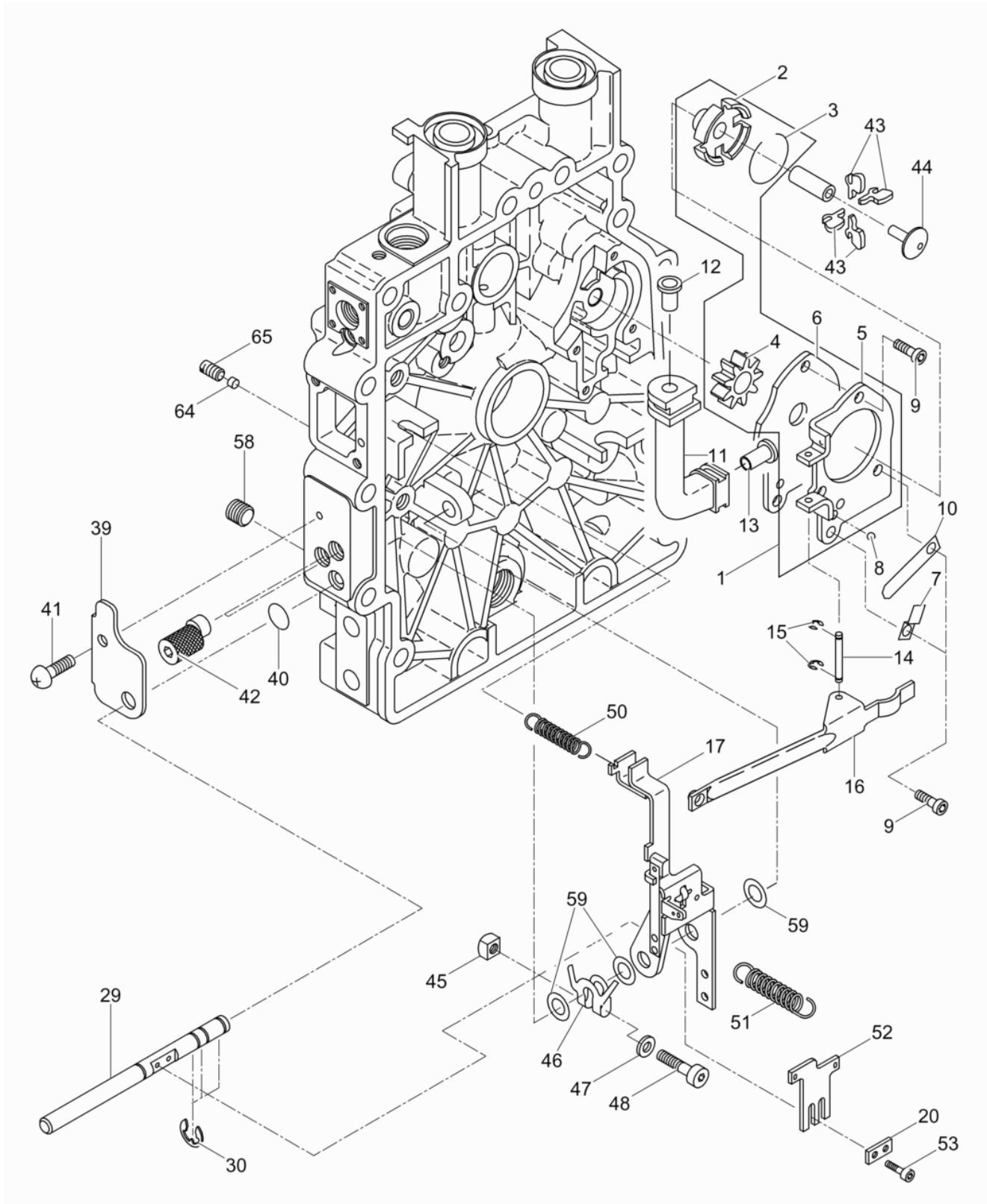

Ref. Pos.	Part No. Artikel Nr.	Qty. St.	Description Beschreibung	Descripción Description	Measurem./Abm.	Norm
					Torque/Drehm.	Sealant Schmierstoff
1	0207031	1	Oil Pump Ölpumpe	Bomba de Aceite Pompe à Huile		
3	0207032	1	Snap ring Sprengring	Anillo de retención Circlip		
7	0108778	1	Retaining strap Winkel	Banda de retención Sangle de fixation		
8	0108779	1	Ball Kugel	Bola Bille	3.5	
9	0151308	4	Cheese head screw Zylinderschraube	Tornillo cilíndrico Vis à tête cylindrique	M5 x 12	DIN6912
10	0108777	1	Spring Feder	Resorte Ressort	0.4	
11	0108775	1	Tube Ölleitung	Tubo Tube		
12	0108774	1	Pipe rivet Rohrniete	Remache de tubo Rivet de tube		
13	0108776	1	Pipe rivet Rohrniete	Remache de tubo Rivet de tube		
14	0108781	1	Shaft Stift	Eje Arbre		
15	0108780	2	Lock washer Sicherungsscheibe	Arandela de seguridad Rondelle d'arrêt	1,9	DIN6799
16	0108785	1	Lever Hebel	Palanca Levier		
17	0151316	1	Governor lever Reglerhebel	Palanca del Gobernador Levier Régulateur		
20	0108789	1	Intermediate plate Zwischenplatte	Placa intermedia Plaque intermediaire		
29	0108795	1	Shaft Welle	Eje Arbre		
30	0151327	3	Lock washer Sicherungsscheibe	Arandela de seguridad Rondelle d'arrêt	7	DIN6799
39	0151330	1	Adjustment R.P.M. Plate Platte Drehzahlverstellung	Ajuste Del No de R.P.M. Placa Réglage du Régime Moteur		
40	0108801	1	O-ring O-Ring	Anillo-O Bague-O	8 x 2	
41	0151328	1	Pan head screw Flachkopfschraube	Tornillo de cabeza plana Vis lentiforme	M5 x 12	DIN7380
42	0129004	2	Eccentric Screw Exzentrerschraube	Tornillo excéntrico Vis excentrique		
43	0207034	4	Governor weight Reglergewichte	Contrapeso del regulador Masselotte		
44	0108773	1	Sleeve Druckstück	Manguito Douille		
45	0151335	1	Nut Vierkantmutter	Tuerca Ecrou	M5	DIN557
46	0108773	1	Sleeve Druckstück	Manguito Douille		
47	0129517	1	Washer Scheibe	Arandela Rondelle	A5,3	ISO7089

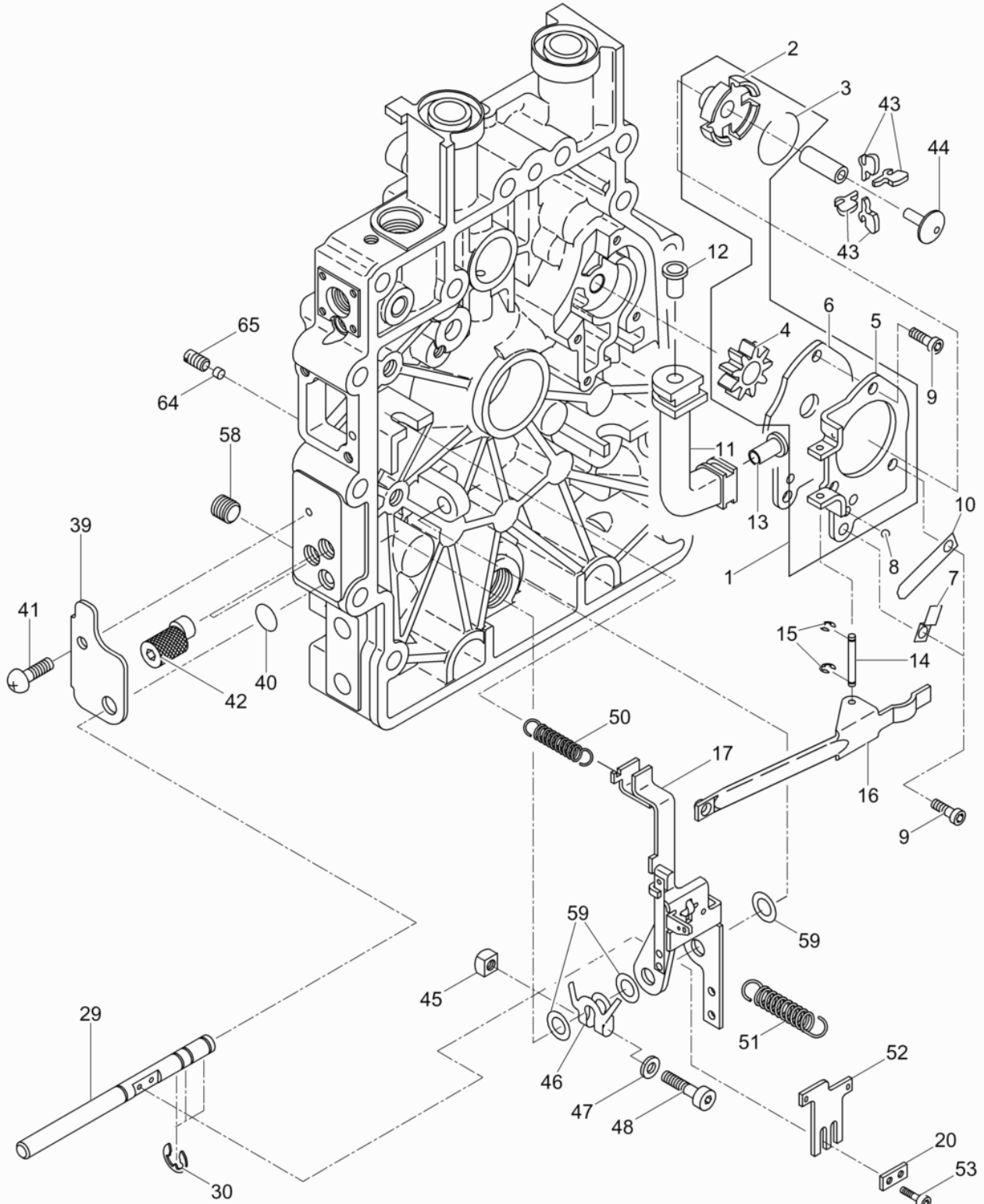

Ref. Pos.	Part No. Artikel Nr.	Qty. St.	Description Beschreibung	Descripción Description	Measurem./Abm.	Norm
					Torque/Drehm.	Sealant Schmierstoff
48	0151333	1	Cheese head screw Zylinderschraube	Tornillo cilíndrico Vis à tête cylindrique	M5 x 25	DIN6912
50	0209739	1	Tension spring Zugfeder	Resorte de tracción Ressort de traction		
51	0207033	1	Spring Feder	Resorte Ressort		
52	0108787	1	Control Blech	Regulador Commande		
53	0108788	2	Cheese head screw Zylinderschraube	Tornillo cilíndrico Vis à tête cylindrique	M3 x 8	
58	0151353	1	Threaded pin Gewindestift	Varilla roscada Goupille fileté	M10 x 10	
59	0151354	3	Shim ring Passscheibe	Arandela de ajuste Disque dajustage	8 x 14 x 1	DIN988
64	0226321	1	Plug Stopfen	Enchufe Prise	4,5x3	
65	0226322	1	Threaded pin Gewindestift	Varilla roscada Goupille fileté	M6x10	

Command Cover
Steuerdeckel
Tapa del mando
Couvercle de commande

DPS 1850H
Asphalt

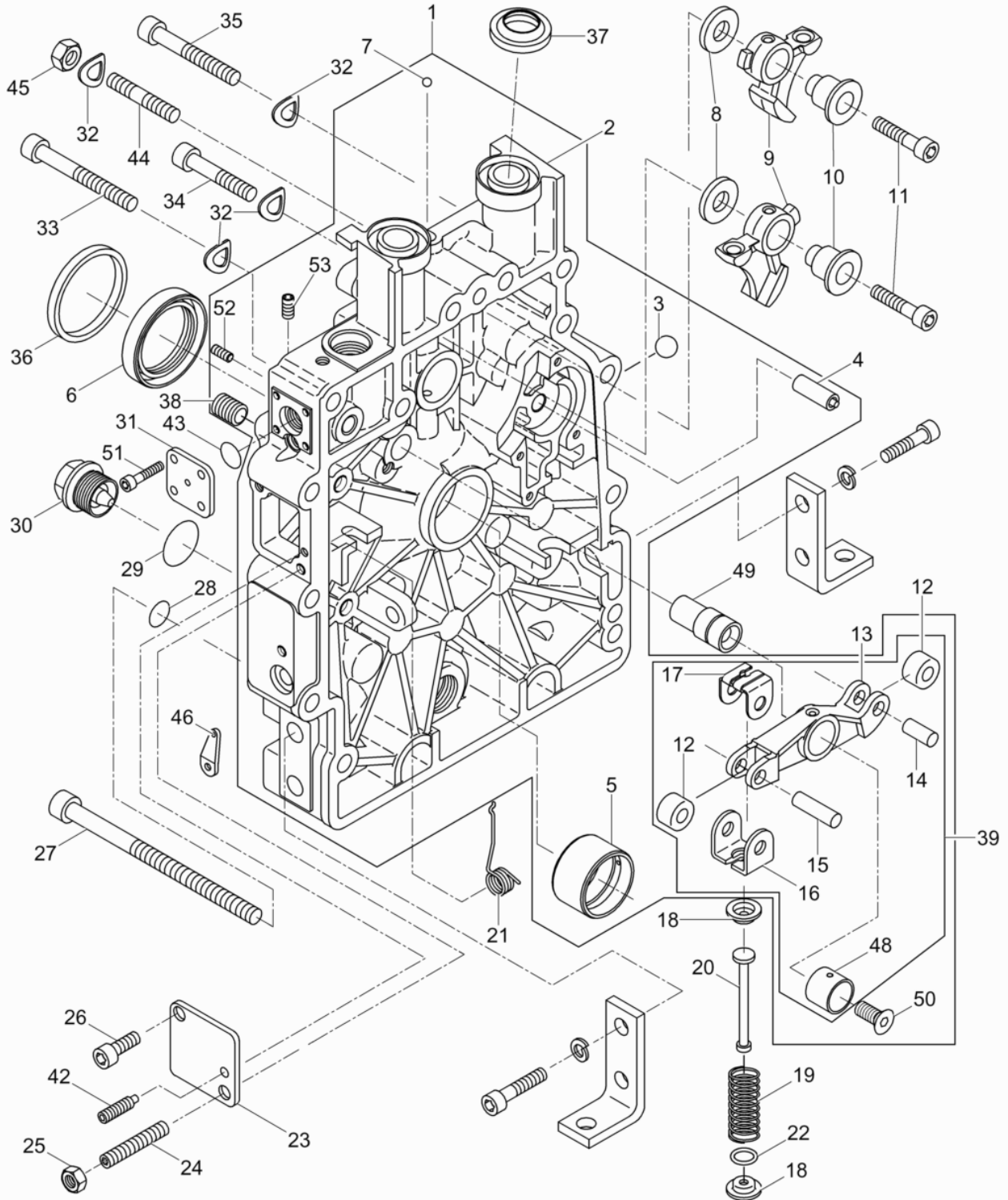

Ref. Pos.	Part No. Artikel Nr.	Qty. St.	Description Beschreibung	Descripción Description	Measurem./Abm.	Norm
					Torque/Drehm.	Sealant Schmierstoff
1	0207036	1	Command Cover Steuerdeckel	Tapa del mando Couvercle de commande		
4	0151356	1	Bolt Bolzen	Perno Boulon		
5	0129006	1	Bearing bushing Lagerbüchse	Caja del cojinete Douille de roulement	0,5	
5	0108763	1	Bearing Lagerbüchse	Rodamiento Roulement		
6	0014458	1	Seal Wellendichtring	Empaque Joint		
8	0104365	2	Washer Scheibe	Arandela Rondelle	10.1 x 22 x 3	
9	0108755	2	Cam Schleppebel	Leva Came		
10	0094936	2	Cam follower spindle shaft Buchse	Rodillo de leva Contre-came		
11	0151361	2	Cheese head screw Zylinderschraube	Tornillo cilíndrico Vis à tête cylindrique	M6 x 25	ISO4762
13	0108766	1	Cover Deckel	Tapa Couvercle		
18	0108760	2	Cup Federteller	Taza Ecuelle		
19	0108762	1	Pressure spring Feder	Resorte de presión Ressort de pression		
20	0108761	1	Rod Zugstange	Varilla Tringle		
21	0108764	1	Governor spring Rückholfeder	Resorte del regulador Ressort régulateur		
22	0151366	1	Washer Scheibe	Arandela Rondelle	10.7 x 19 x 0.5	
24	0151368	1	Threaded pin Gewindestift	Varilla roscada Goupille fileté	M6 x 30	DIN913
25	0151323	1	Locknut Sechskantmutter	Contratuercas Contre-écrou	M6	ISO4032
26	0151370	1	Cheese head screw Zylinderschraube	Tornillo cilíndrico Vis à tête cylindrique	M6 x 12	ISO4762
27	0129519	2	Cheese head screw Zylinderschraube	Tornillo cilíndrico Vis à tête cylindrique	M8 x 120	
28	0107556	2	Gasket Dichtring	Anillo de junta Bague détanchéité	A8 x 14	DIN7603
29	0202416	1	Oil Seal Öldichtung	Junta de Aceite Joint D'Huile	52 x 80 x 10	
30	0202314	1	Oil plug Verschlußschraube	Tapón roscado Bouchon	AM 22x 1,5	DIN7604
31	0151372	1	Cover Deckel	Tapa Couvercle		
32	0013601	13	Spring washer Federscheibe	Arandela elástica Rondelle à ressort	A8	DIN137
33	0126979	1	Cheese head screw Zylinderschraube	Tornillo cilíndrico Vis à tête cylindrique	M8 x 60	DIN912

Command Cover
Steuerdeckel
Tapa del mando
Couvercle de commande

DPS 1850H
Asphalt

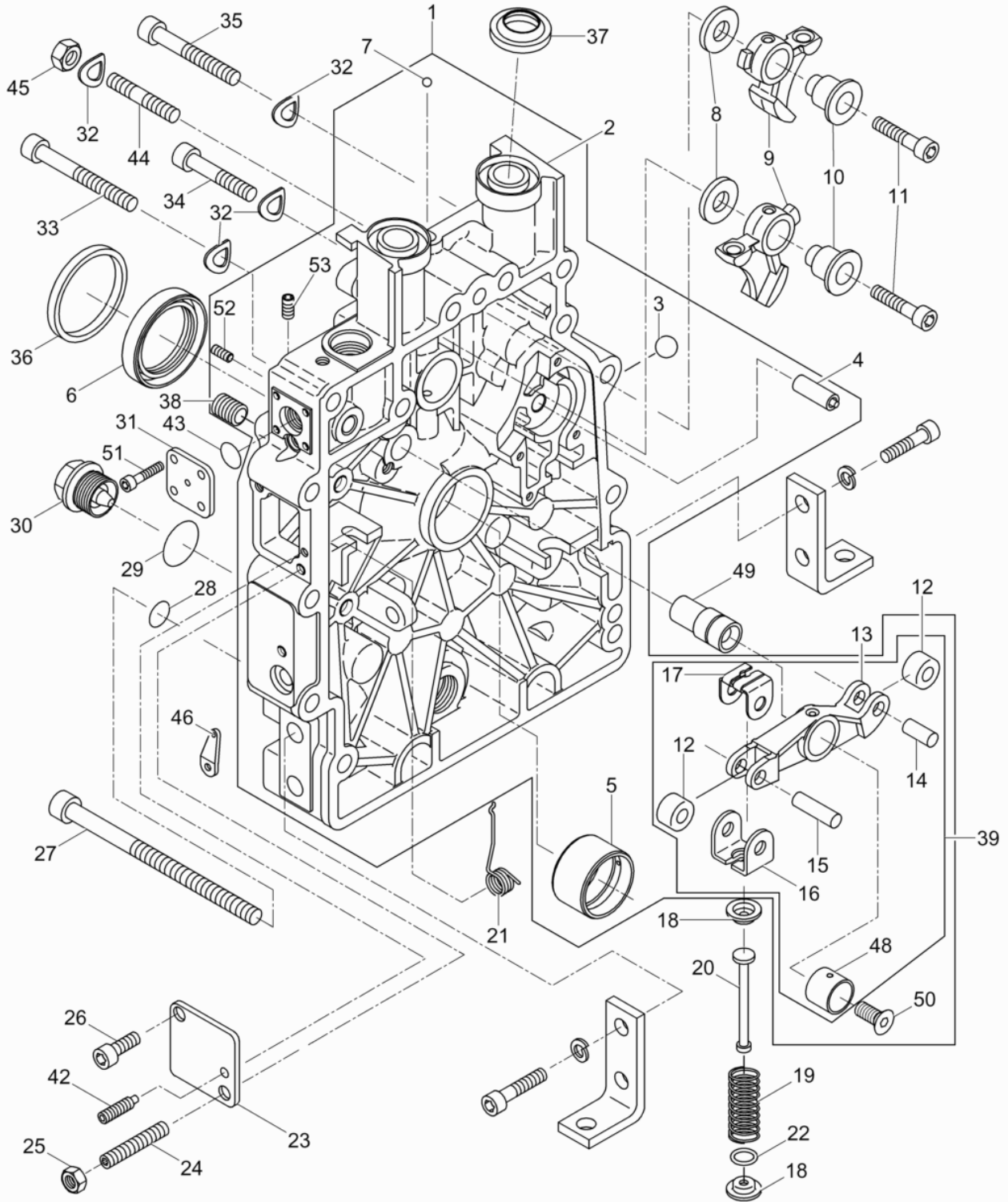

Ref. Pos.	Part No. Artikel Nr.	Qty. St.	Description Beschreibung	Descripción Description	Measurement./Abm.	Norm
					Torque/Drehm.	Sealant Schmierstoff
34	0151375	2	Cheese head screw Zylinderschraube	Tornillo cilíndrico Vis à tête cylindrique	M8 x 45	ISO4762
35	0151376	10	Cheese head screw Zylinderschraube	Tornillo cilíndrico Vis à tête cylindrique	M8 x 50	ISO4762
37	0108770	2	Seal ring Dichtring	Anillo sellante Bague d'étanchéité		
38	0202302	5	Threaded pin Gewindestift	Varilla roscada Goupille fileté	M8 x 10	DIN913
39	0207037	1	Exhaust rocker arm Rocker arm Kipphebel	Balancín de escape Balancín Culbuteur Culbuteur		
42	0108765	1	Screw Gewindestift	Tornillo Vis	M4 x 20	DIN915
43	0094934	1	O-Ring O-Ring	Anillo-O Joint torique	9,5 x 2,5	
46	0151383	1	Lever Hebel	Palanca Levier		
49	0215778	1	Lock Kipphebelachse	Seguro Verrou		
50	0108929	1	Screw Senkschraube	Tornillo Vis	M6 x 35	DIN7991
51	0151341	4	Cheese head screw Zylinderschraube	Tornillo cilíndrico Vis à tête cylindrique	M4 x 10	ISO4762
52	0151342	2	Threaded pin Gewindestift	Varilla roscada Goupille fileté	M5 x 10	DIN916
53	0107715	1	Pin Stift	Pasador Goupille	M6 x 10	

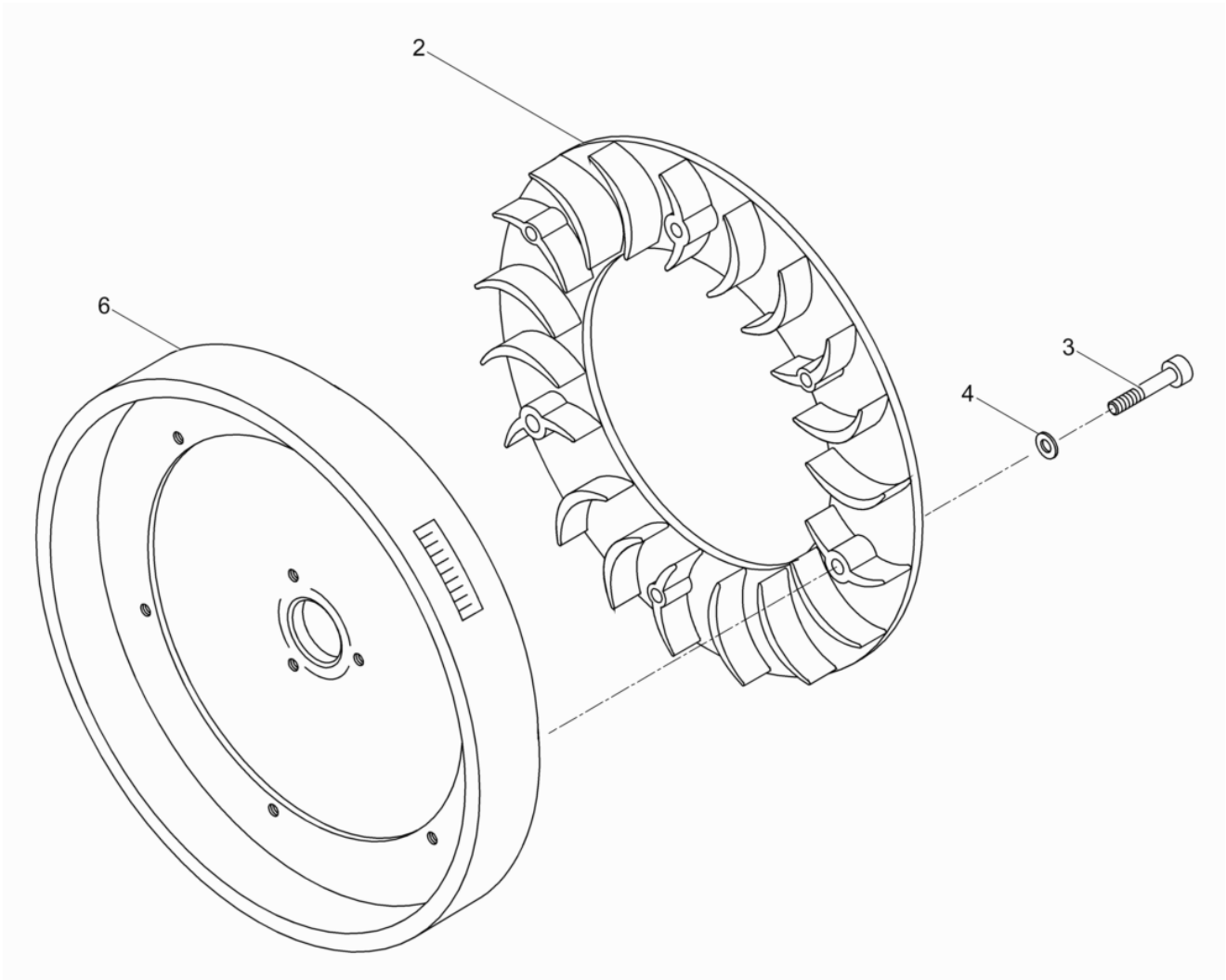

Ref. Pos.	Part No. Artikel Nr.	Qty. St.	Description Beschreibung	Descripción Description	Measurement/Abm.	Norm
					Torque/Drehm.	Sealant Schmierstoff
2	0108711	1	Ring Lüfterrad	Anillo Anneau		
3	0151389	6	Cheese head screw Zylinderschraube	Tornillo cilíndrico Vis à tête cylindrique	M4 x 20	ISO4762
4	0151390	6	Spring washer Federscheibe	Arandela elástica Rondelle à ressort	A4	DIN137
6	0129509	1	Flywheel Schwungrad	Volante Volant		

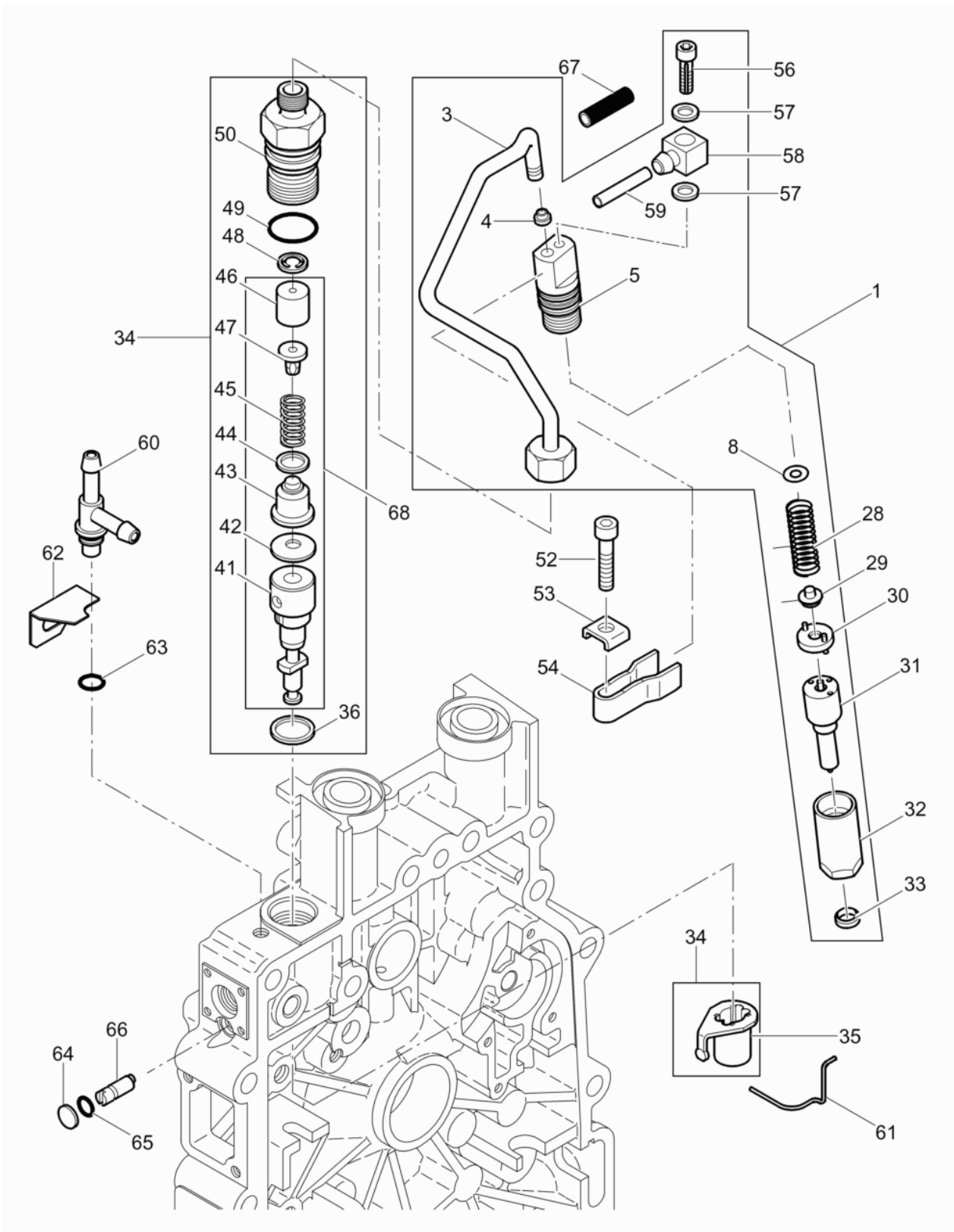

Ref. Pos.	Part No. Artikel Nr.	Qty. St.	Description Beschreibung	Descripción Description	Measurem./Abm.	Norm
					Torque/Drehm.	Sealant Schmierstoff
1	0226318	1	Injection Valve cpl. Einspritzventil kpl.	Válvula de Inyección cpl. Soupape de Injection cpl.		
4	0151396	1	Sealing Cone Dichtkonus	Cono de obturación Cône d'étanchéité	5,3 LG	
8	0151398	1	Adjusting Washer Einstellscheibe	Arandela de ajuste Rondelle de réglage	1,00	
8	0151417	1	Adjusting Washer Einstellscheibe	Arandela de ajuste Rondelle de réglage	1,94	
8	0151416	1	Adjusting Washer Einstellscheibe	Arandela de ajuste Rondelle de réglage	1,90	
8	0151415	1	Adjusting Washer Einstellscheibe	Arandela de ajuste Rondelle de réglage	1,84	
8	0151414	1	Adjusting Washer Einstellscheibe	Arandela de ajuste Rondelle de réglage	1,80	
8	0151413	1	Adjusting Washer Einstellscheibe	Arandela de ajuste Rondelle de réglage	1,74	
8	0151412	1	Adjusting Washer Einstellscheibe	Arandela de ajuste Rondelle de réglage	1,70	
8	0151411	1	Adjusting Washer Einstellscheibe	Arandela de ajuste Rondelle de réglage	1,64	
8	0151410	1	Adjusting Washer Einstellscheibe	Arandela de ajuste Rondelle de réglage	1,60	
8	0151409	1	Adjusting Washer Einstellscheibe	Arandela de ajuste Rondelle de réglage	1,54	
8	0151408	1	Adjusting Washer Einstellscheibe	Arandela de ajuste Rondelle de réglage	1,50	
8	0151407	1	Adjusting Washer Einstellscheibe	Arandela de ajuste Rondelle de réglage	1,44	
8	0151406	1	Adjusting Washer Einstellscheibe	Arandela de ajuste Rondelle de réglage	1,40	
8	0151405	1	Adjusting Washer Einstellscheibe	Arandela de ajuste Rondelle de réglage	1,34	
8	0151404	1	Adjusting Washer Einstellscheibe	Arandela de ajuste Rondelle de réglage	1,30	
8	0151403	1	Adjusting Washer Einstellscheibe	Arandela de ajuste Rondelle de réglage	1,24	
8	0151402	1	Adjusting Washer Einstellscheibe	Arandela de ajuste Rondelle de réglage	1,20	
8	0151401	1	Adjusting Washer Einstellscheibe	Arandela de ajuste Rondelle de réglage	1,14	
8	0151400	1	Adjusting Washer Einstellscheibe	Arandela de ajuste Rondelle de réglage	1,10	
8	0151399	1	Adjusting Washer Einstellscheibe	Arandela de ajuste Rondelle de réglage	1,04	
31	0226323	1	Injection Nozzle Einspritzdüse	Inyector Injecteur		
33	0108805	1	Seal Dichtscheibe	Empaque Joint		
34	0226317	1	Injection pump cpl. Einspritzpumpe kpl.	Bomba de inyección cpl. Pompe à injection cpl.		

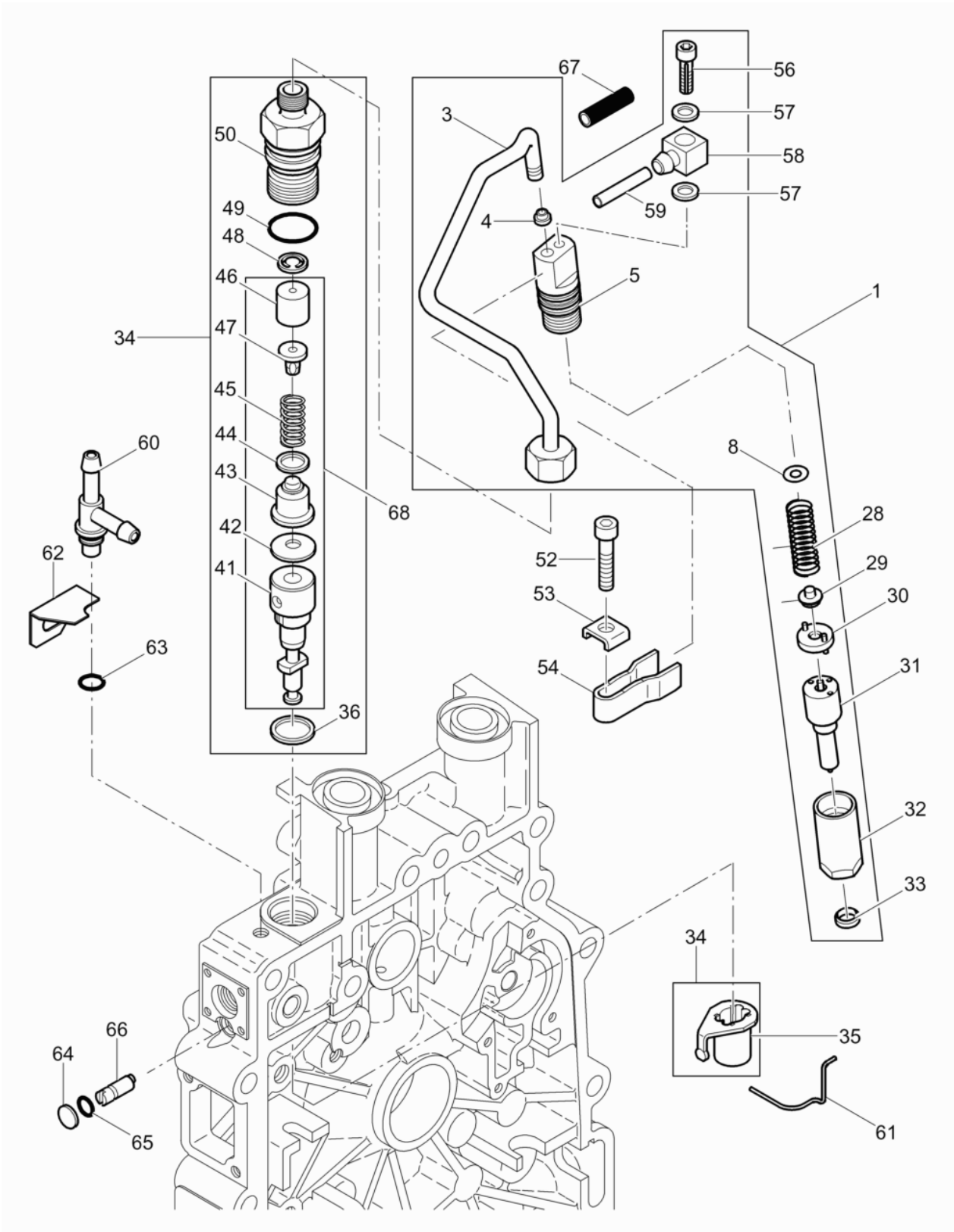

Ref. Pos.	Part No. Artikel Nr.	Qty. St.	Description Beschreibung	Descripción Description	Measurem./Abm.	Norm
					Torque/Drehm.	Sealant Schmierstoff
35	0108806	1	Sleeve Reglerbuchse	Manguito Douille		
36	0108809	1	Shim Ausgleichsscheibe	Laminilla Cale	0,2	
36	0108810	1	Shim Ausgleichsscheibe	Laminilla Cale	0,3	
36	0108811	1	Shim Ausgleichsscheibe	Laminilla Cale	0,4	
36	0108812	1	Shim Ausgleichsscheibe	Laminilla Cale	0,5	
36	0108813	1	Shim Ausgleichsscheibe	Laminilla Cale	0,6	
42	0151427	1	Spring washer Spannscheibe	Arandela elástica Disque de serrage		
44	0151428	1	Washer Scheibe	Arandela Rondelle		
48	0205822	1	Cover Ventilplatte	Tapa Couvercle		
49	0151429	1	O-Ring O-Ring	Anillo-O Joint torique	17 x 2	
50	0205822	1	Cover Ventilplatte	Tapa Couvercle		
52	0129007	1	Cheese head screw Zylinderschraube	Tornillo cilíndrico Vis à tête cylindrique	M6 x 30	ISO4762
53	0108808	1	Washer Scheibe	Arandela Rondelle		
54	0108807	1	Holder Halter	Soporte Attache		
56	0215782	1	Cheese head screw Zylinderschraube	Tornillo cilíndrico Vis à tête cylindrique	M4x16	
57	0151439	2	Gasket Dichtring	Anillo de junta Bague détanchéité	A4 x 8	DIN7603
58	0108803	1	Connector Anschlußstück	Conector Connexion		
59	0128968	1	Fuel Pipe Kraftstoffleitung	Tubería de Combustible Tuyau à Combustible	2,5 x 195	
60	0209682	1	T-piece T-Stück	Pieza T T-pièce		
61	0151369	1	Retaining spring Haltefeder	Resorte de sujeción Ressort de retenue		
62	0128967	1	Angle Haltewinkel	Angulo Coude		
63	0071130	1	O-ring O-Ring	Anillo-O Bague-O	7,5 x 10,5 x 1,5	
64	0108816	1	Plug washer Verschlusscheibe	Arandela de cierre Rondelle de fermeture	8	DIN470
65	0094905	1	O-Ring O-Ring	Anillo-O Joint torique		
66	0151433	1	Eccentric pin Exzenterbolzen	Perno excéntrico Boulon d'excentrage		

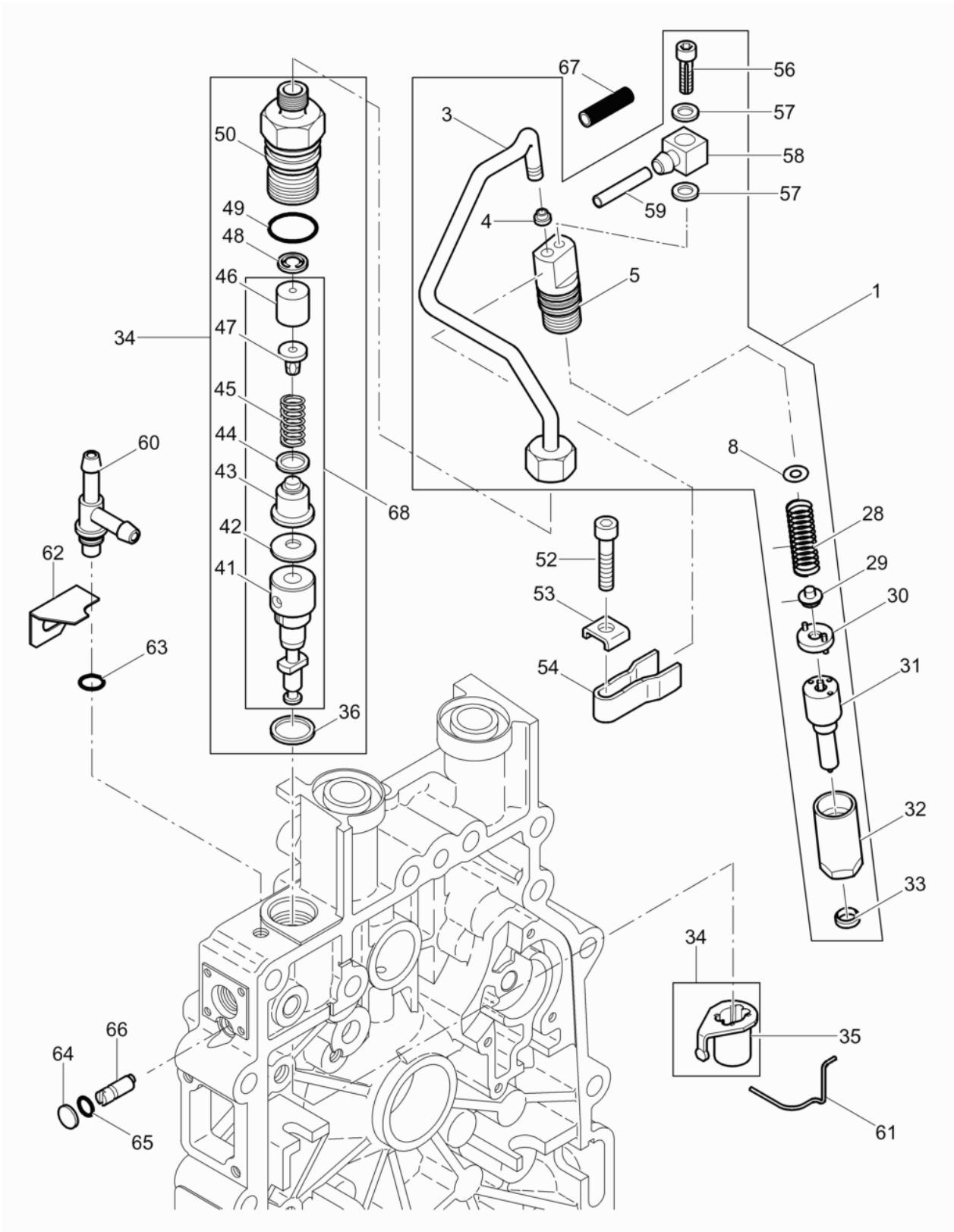

Ref. Pos.	Part No. Artikel Nr.	Qty. St.	Description Beschreibung	Descripción Description	Measurem./Abm.	Norm
					Torque/Drehm.	Sealant Schmierstoff
67	0209721	1	Fuel hose Schlauch	Manguera de combustible Tuyau à essence	145mm	
69	0215785	1	Clamp Schlauchklemme	Abrazadera Collier de serrage	6	

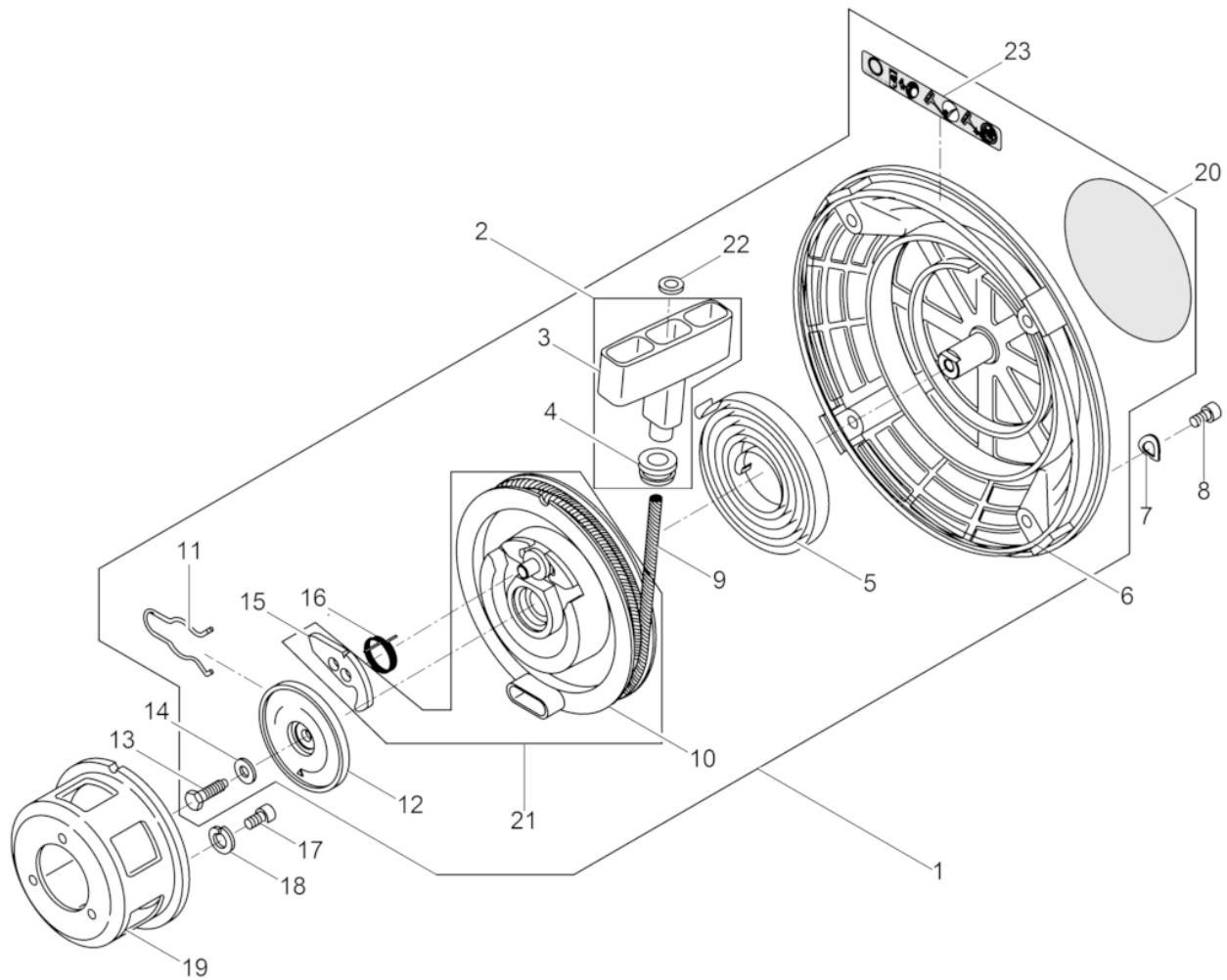

Ref. Pos.	Part No. Artikel Nr.	Qty. St.	Description Beschreibung	Descripción Description	Measurem./Abm.	Norm
					Torque/Drehm.	Sealant Schmierstoff
1	0205792	1	Starter cpl. Starter kpl.	Starter cpl. Starter cpl.		
2	0108830	1	Starter handle Griff kpl.	Empuñadura del arranque Poignée du lanceur		
4	0058711	1	Rubber funnel Gummitülle	Casquillo de goma Passe fil en caoutchouc	0,390in	
5	0108827	1	Spring Rückholfeder	Resorte Ressort		
6	0108826	1	Starter housing Startergehäuse	Caja del arrancador Carter de démarrage		
7	0151290	4	Spring washer Federscheibe	Arandela elástica Rondelle à ressort	A6	DIN137
8	0151448	4	Cheese head screw Zylinderschraube	Tornillo cilíndrico Vis à tête cylindrique	M6 x 10	ISO4762
9	0205791	1	Rope Starterseil	Cuerda Corde		
11	0108831	1	Brake Spring Bremsfeder	Resorte de Freno Ressort de Décélération		
12	0108834	1	Washer Bremscheibe	Arandela Rondelle		
13	0151452	1	Hexagonal head cap screw Sechskantschraube	Tornillo hexagonal Vis à tête hexagonale	M6 x 18	DIN933
14	0207593	1	Spring washer Spannscheibe	Arandela elástica Disque de serrage		
15	0108833	1	Ratchet (pawl) Klinke	Trinquete Cliquet		
16	0108832	1	Torsion spring Drehfeder	Resorte Ressort		
17	0151448	3	Cheese head screw Zylinderschraube	Tornillo cilíndrico Vis à tête cylindrique	M6 x 10	ISO4762
18	0151456	3	Lock washer Federring	Arandela elástica Rondelle de ressort	6	DIN128
19	0108835	1	Sleeve Mitnehmertopf	Manguito Douille		
20	0227678	1	Labels Aufkleber	Calcomanias Autocollants		
21	0069666	1	Rope Disc and Ratchet Seilscheibe und Klinke	Polea Para Cuerda y Trinquete Poulie de Démarrage et Cliquet		
22	0129008	1	Washer Scheibe	Arandela Rondelle	5,3	DIN9021
23	0215784	1	Label Aufkleber	Calcomania Autocollant		

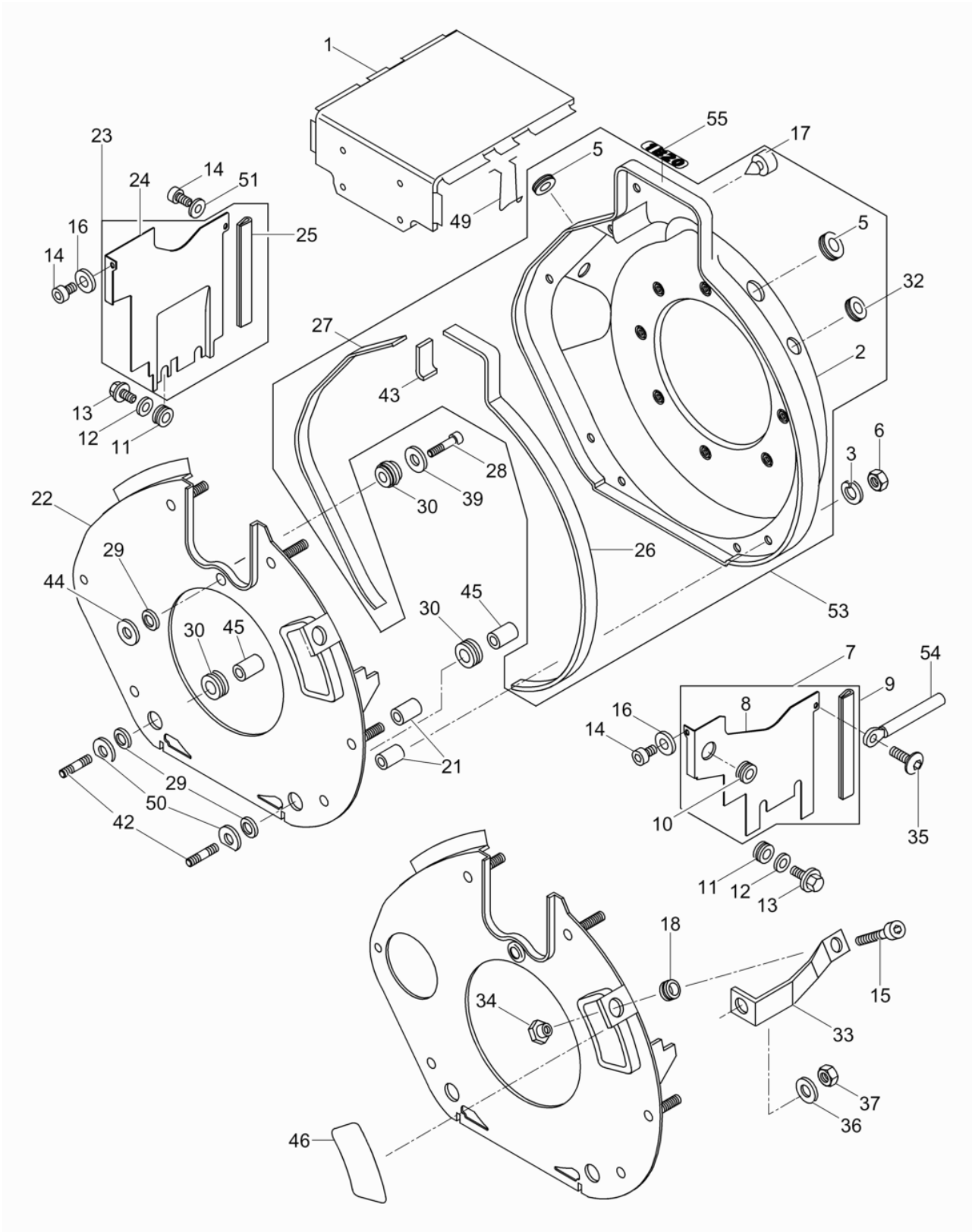

Ref. Pos.	Part No. Artikel Nr.	Qty. St.	Description Beschreibung	Descripción Description	Measur./Abm.	Norm
					Torque/Drehm.	Sealant Schmierstoff
1	0108836	1	Cover plate Abdeckblech	Cubierta de chapa Tôle de recouvrement		
3	0151456	6	Lock washer Federring	Arandela elástica Rondelle de ressort	6	DIN128
5	0129520	2	Rubber funnel Gummitülle	Casquillo de goma Passe fil en caoutchouc		
6	0151323	6	Locknut Sechskantmutter	Contratuercas Contre-écrou	M6	ISO4032
7	0108839	1	Duct Blech kpl.	Cubierta Canal d'air		
9	0108841	1	Seal Dichtleiste	Empaque Joint		
10	0107379	1	Grommet Gummitülle	Ojal Passe-fil		
11	0108842	4	Sleeve Gummitülle	Manguito Douille		
12	0108843	3	Washer Scheibe	Arandela Rondelle	4,3	DIN9021
13	0108844	3	Screw Schraube	Tornillo Vis	DE M4 x 10	DIN7500
14	0202304	3	Cheese head screw Zylinderschraube	Tornillo cilíndrico Vis à tête cylindrique	M6 x 16	DIN6912
15	0151231	1	Cheese head screw Zylinderschraube	Tornillo cilíndrico Vis à tête cylindrique	M6 x 16	ISO4762
16	0151324	2	Washer Scheibe	Arandela Rondelle	6.4	
17	0107493	1	Blind grommet Blindtülle	Boquilla ciego Douille		
18	0108845	1	Rubber funnel Gummitülle	Casquillo de goma Passe fil en caoutchouc		
21	0108852	5	Spacer tube Hülse	Tubo Tube	6,5 x 12 x 18	
22	0129502	1	Baffle plate Trennblech	Placa separadora Separateur		
23	0129491	1	Plate Blech	Chapa Tôle		
25	0108841	1	Seal Dichtleiste	Empaque Joint		
26	0108855	1	Seal Dichtleiste	Empaque Joint	470	
27	0108857	1	Seal Dichtstreifen	Tira Sellante Plaque D'Étanchéité	388	
28	0129010	1	Cheese head screw Zylinderschraube	Tornillo cilíndrico Vis à tête cylindrique	M6 x 25	DIN912
29	0107800	3	Sealing ring Dichtungsring	Anillo sellante Bague d'étanchéité		
30	0209664	3	Spacer sleeve Distanzhülse	Manguito distanciador Douille d'écartement		
32	0108838	1	Sleeve Gummitülle	Manguito Douille		

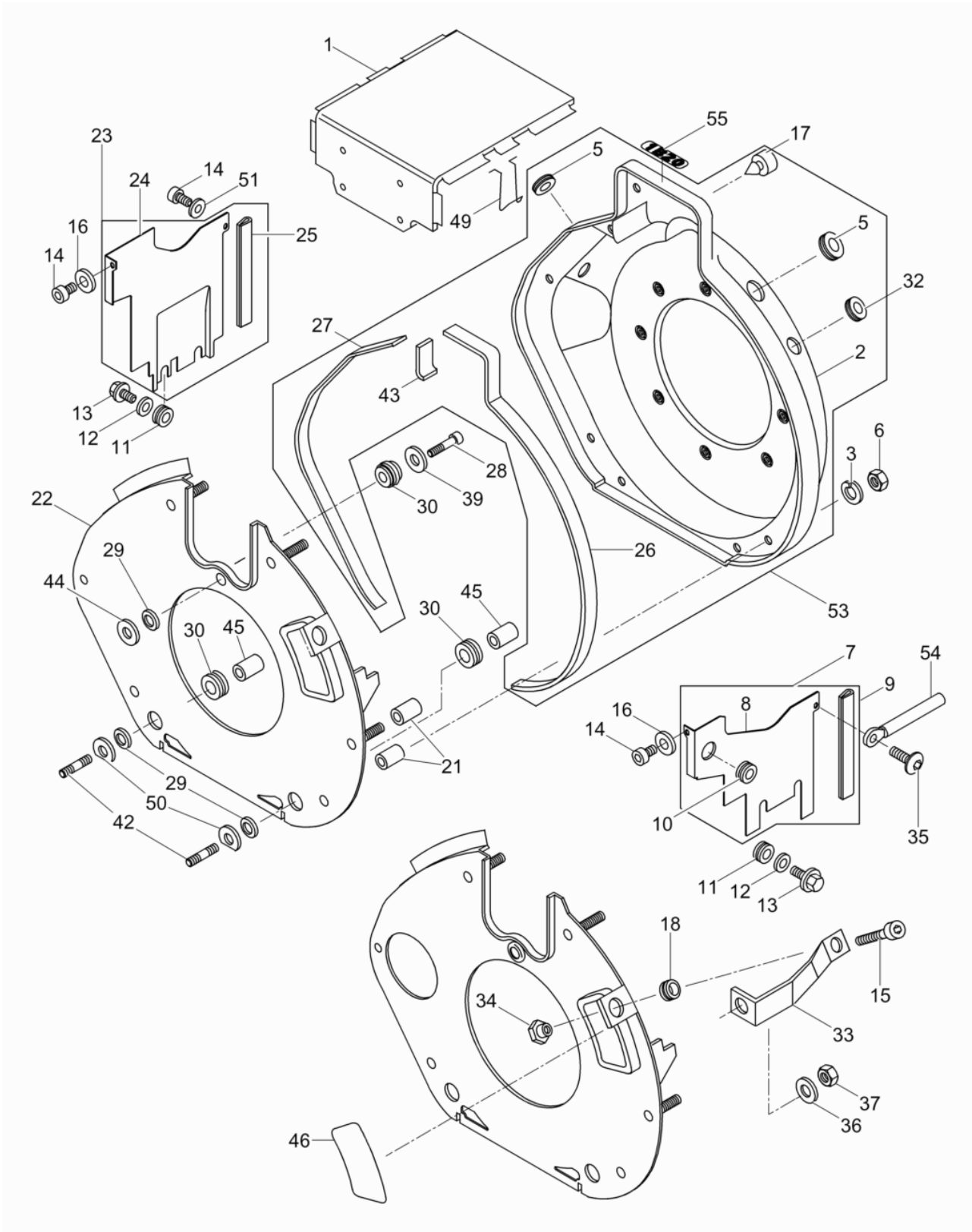

Ref. Pos.	Part No. Artikel Nr.	Qty. St.	Description Beschreibung	Descripción Description	Measurement./Abm.	Norm
					Torque/Drehm.	Sealant Schmierstoff
33	0108847	1	Bracket Abstützung	Soporte Support		
34	0108846	1	Screw Schraube	Tornillo Vis		
35	0126983	1	Pan head screw Flachkopfschraube	Tornillo de cabeza plana Vis lentiforme	M6 x 12 14Nm/10ft.lbs	DIN7380
36	0013601	1	Spring washer Federscheibe	Arandela elástica Rondelle à ressort	A8	DIN137
37	0108848	1	Nut Mutter	Tuerca Écrou		
39	0151456	1	Lock washer Federring	Arandela elástica Rondelle de ressort	6	DIN128
42	0108850	2	Stud bolt Stiftschraube	Tornillo espárrago Goupille fileté	M6 x 45	DIN835
43	0108856	1	Seal Dichtungsprofil	Empaque Joint	48	
44	0108851	1	Washer Scheibe	Arandela Rondelle	6,5 x 22,5 x 1	
45	0108852	2	Spacer tube Hülse	Tubo Tube	6,5 x 12 x 18	
46	0202307	1	Fuel tank cap Verschlußdeckel	Tapa del tanque de combustible Chapeau de réservoir à essence		
49	0129513	1	Spring Feder	Resorte Ressort		
50	0151482	2	Washer Scheibe	Arandela Rondelle		
51	0107261	1	Washer Scheibe	Arandela Rondelle		
53	0108837	1	Blower housing (shroud) Lüfterhaube	Cubierta Boîtier du ventilateur		
54	0097590	1	Clamp Schelle	Abrazadera Agrafe		
55	0215783	1	Label Aufkleber	Calcomania Autocollant		

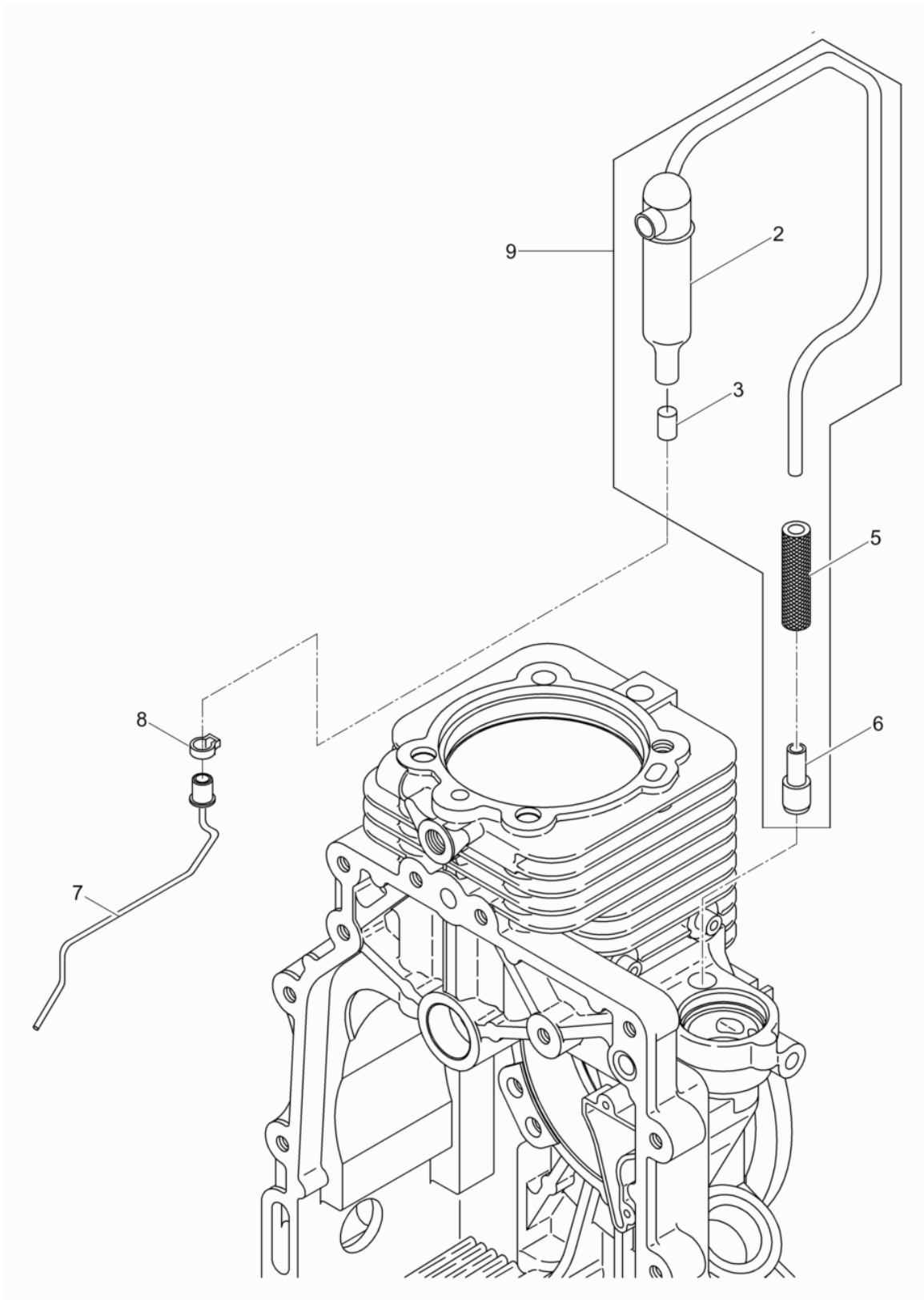

Ref. Pos.	Part No. Artikel Nr.	Qty. St.	Description Beschreibung	Descripción Description	Measurement./Abm.	Norm
					Torque/Drehm.	Sealant Schmierstoff
3	0108822	1	Filter insert Filtereinsatz	Cartucho filtrante Element filtrant		
5	0209712	1	Fuel hose Kraftstoffleitung	Manguera de combustible Tuyau à essence	6x35	
6	0209730	1	Nipple Nippel	Boquilla roscada Raccord fileté		
7	0108820	1	Suction pipe Saugrohr	Tubo aspirante Tuyau d'aspiration		
8	0202305	1	Clamp Schlauchklemme	Abrazadera Collier de serrage		
9	0108821	1	Oil filter Entlüftung kpl.	Filtro de aceite Filtre d'huile		

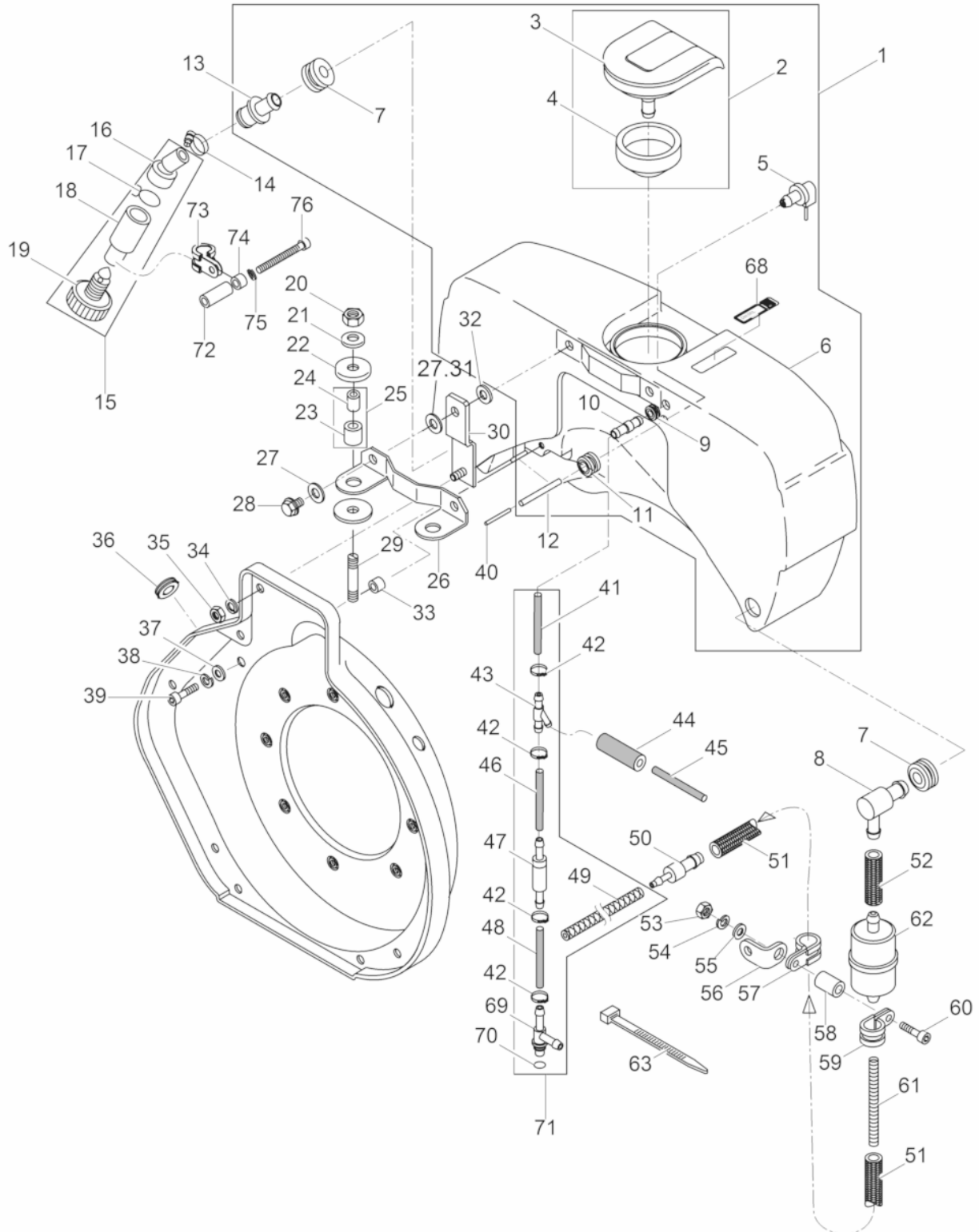

Ref. Pos.	Part No. Artikel Nr.	Qty. St.	Description Beschreibung	Descripción Description	Measurement/Abm.	Norm
					Torque/Drehm.	Sealant Schmierstoff
1	0209965	1	Fuel Tank Kraftstofftank	Depósito de Combustible Réservoir à Essence		
2	0108861	1	Cap Tankverschluß	Tapa Couvercle		
4	0108864	1	Gasket Formstück	Junta Joint		
5	0108870	1	Valve Ventil	Válvula Soupape		
7	0108874	2	Sleeve Gummitülle	Manguito Douille		
8	0209869	1	Connecting nipple Anschlussnippel	Boquilla de conexión Raccord fileté		
9	0108885	1	Sleeve Gummitülle	Manguito Douille		
10	0128962	1	Nipple Nippel	Boquilla roscada Raccord fileté		
11	0108866	1	Sleeve Gummitülle	Manguito Douille		
12	0108887	1	Hose Schlauchstück	Manguera Tuyau	1 x 3 x 85	
13	0209719	1	Connecting nipple Anschlußnippel	Boquilla de conexión Raccord fileté		
14	0202465	1	Clamp Schelle	Abrazadera Collier		
15	0209871	1	Water Separator cpl. Wasserabscheider kpl	Separador de agua cpl.ua Separateur d'eau cpl.		
16	0202412	1	Fuel hose Schlauch 20x12mm	Manguera de combustible Tuyau à essence	20 x 12	
17	0108688	1	Clip Schlauchklemme	Sujetador Agrafe		
18	0209707	1	Water Separator Wasserabscheider	Dispositivo para Separar el Agua Purgeur de Diesel-Oil		
19	0202461	1	Screw Schraube M10	Tornillo Vis	M10	
20	0151530	2	Locknut Sechskantmutter	Contratuercas Contre-écrou	M8	
21	0151553	2	Washer Scheibe	Arandela Rondelle	B8,4	ISO7089
22	0108892	4	Disc Scheibe	Disco Disque	8,2 x 22 x 2	
24	0108895	2	Sleeve Hülse	Manguito Douille		
25	0151489	2	Insulating Pipe cpl. Isolierrohr kpl.	Cuerda cpl. Tube Isolant cpl.		
26	0108893	1	Brace Halter	Apoyo Ventrière		
27	0108791	4	Disc Scheibe	Disco Disque	7,1 x 17,9 x 2	
28	0108891	2	Screw Schraube	Tornillo Vis	M6 x 16	

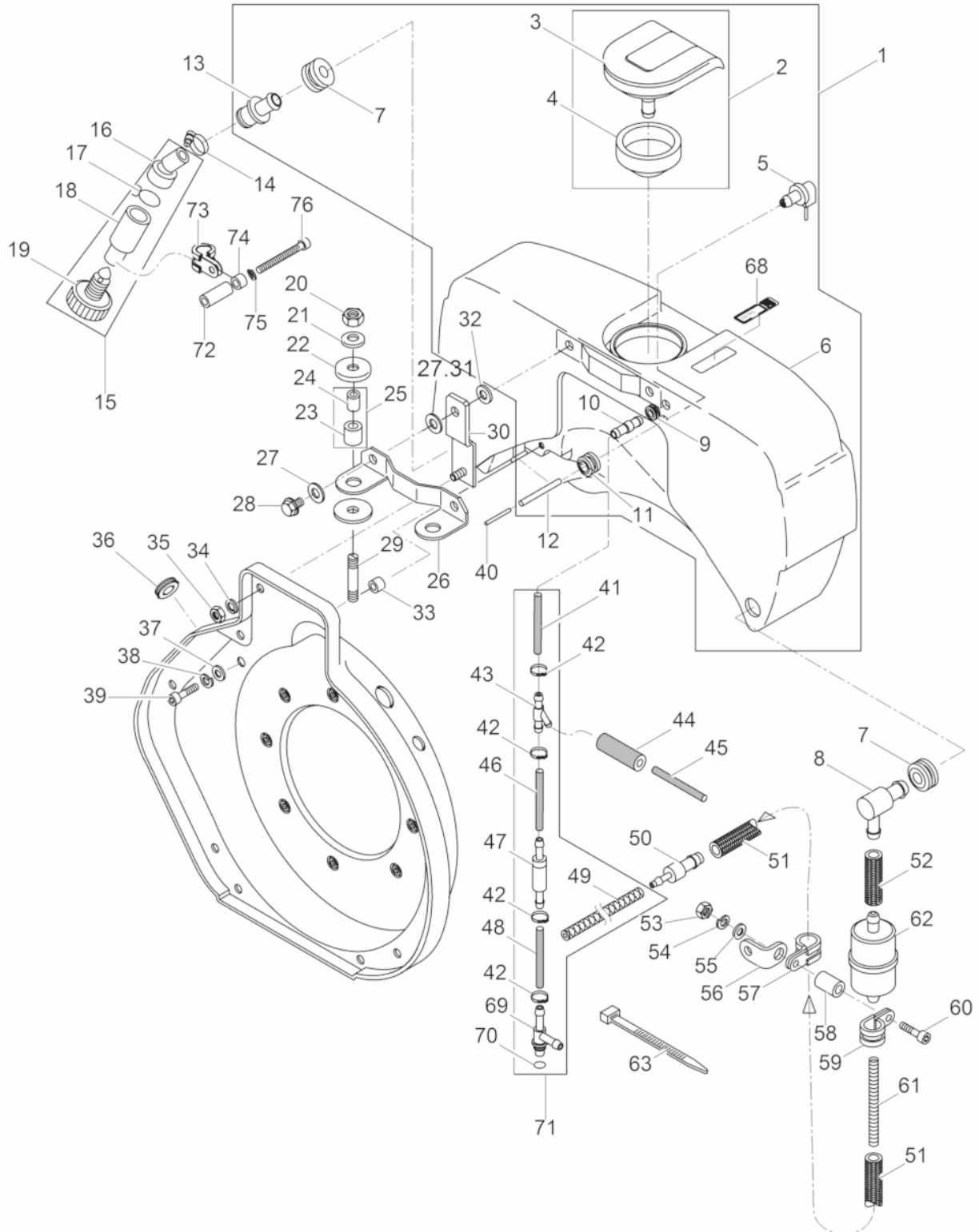

Ref. Pos.	Part No. Artikel Nr.	Qty. St.	Description Beschreibung	Descripción Description	Measurement/Abm.	Norm
					Torque/Drehm.	Sealant Schmierstoff
29	0151526	2	Stud Stiftschraube	Perno prisionero Boulon	M8 x 25	DIN825
30	0108896	2	Brace Bügel	Apoyo Ventrière		
32	0151540	2	Washer Scheibe	Arandela Rondelle	A6,4	DIN9021
33	0108890	2	Washer Scheibe	Arandela Rondelle	6,5 x 13 x 4,8	
34	0151456	2	Lock washer Federring	Arandela elástica Rondelle de ressort	6	DIN128
35	0151323	2	Locknut Sechskantmutter	Contratuerca Contre-écrou	M6	ISO4032
36	0108889	2	Rubber funnel Gummitülle	Casquillo de goma Passe fil en caoutchouc		
37	0151324	2	Washer Scheibe	Arandela Rondelle	6.4	
38	0151456	2	Lock washer Federring	Arandela elástica Rondelle de ressort	6	DIN128
39	0151231	2	Cheese head screw Zylinderschraube	Tornillo cilíndrico Vis à tête cylindrique	M6 x 16	ISO4762
40	0108888	1	Pipe Rohr	Tubo Tube	1,4 x 2 x 16	
41	0209966	1	Fuel hose Kraftstoffleitung	Manguera de combustible Tuyau à essence		
42	0207586	4	Clamp Schlauchklemme	Abrazadera Collier de serrage		
43	0128959	2	Tee-Stem For Hose T-Schlauchnippel	Boquilla para manguera en T Raccord de flexible T		
44	0209716	2	Fuel hose Schlauch	Manguera de combustible Tuyau à essence	7x25	
45	0128968	1	Fuel Pipe Kraftstoffleitung	Tubería de Combustible Tuyau à Combustible	2,5 x 195	
46	0207528	1	Fuel Pipe Kraftstoffleitung	Tubería de Combustible Tuyau à Combustible		
47	0047977	1	Hose fitting Ventil	Unión Raccord		
48	5100003877	1	Fuel Pipe Kraftstoffleitung	Tubería de Combustible Tuyau à Combustible		
49	0095018	1	Hose Leitung	Manguera Tuyau	160	
50	0209876	1	Nipple Nippel	Boquilla roscada Raccord fileté		
51	0209877	1	Fuel hose Kraftstoffleitung	Manguera de combustible Tuyau à essence	7x260	
52	0209967	1	Fuel hose Kraftstoffleitung	Manguera de combustible Tuyau à essence		
53	0151323	1	Locknut Sechskantmutter	Contratuerca Contre-écrou	M6	ISO4032
54	0151456	1	Lock washer Federring	Arandela elástica Rondelle de ressort	6	DIN128

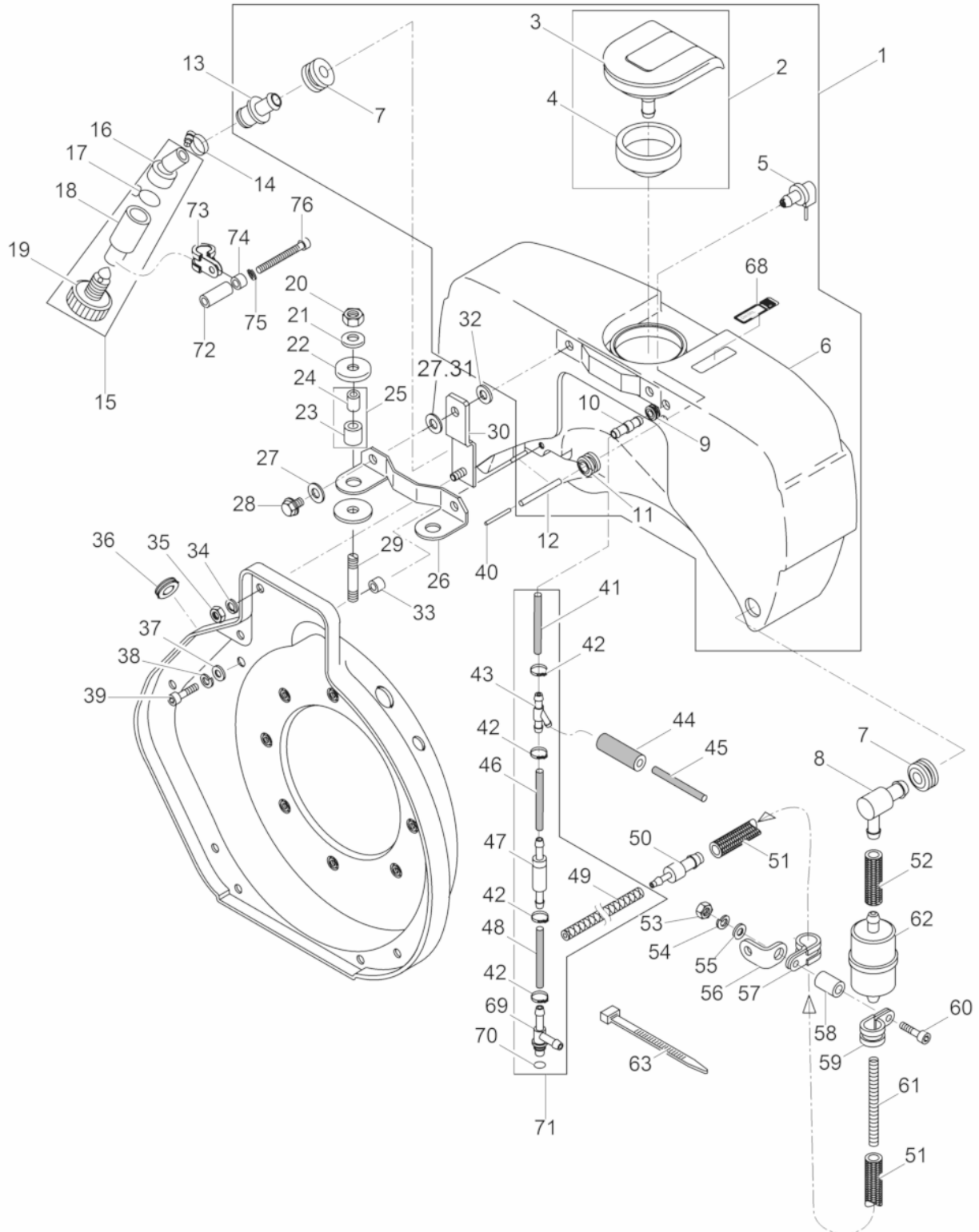

Ref. Pos.	Part No. Artikel Nr.	Qty. St.	Description Beschreibung	Descripción Description	Measurement/Abm.	Norm
					Torque/Drehm.	Sealant Schmierstoff
55	0151324	1	Washer Scheibe	Arandela Rondelle	6.4	
56	0209879	1	Retaining strap Winkel	Banda de retención Sangle de fixation		
57	0107451	1	Clamp Schelle	Abrazadera Agrafe		
58	0108852	1	Spacer tube Hülse	Tubo Tube	6,5 x 12 x 18	
59	0107451	1	Clamp Schelle	Abrazadera Agrafe		
60	0209880	1	Cheese head screw Zylinderschraube	Tornillo cilíndrico Vis à tête cylindrique	M 6x40	
61	0106564	1	Spring Feder	Resorte Ressort		
62	0022832	1	Fuel filter Kraftstofffilter	Filtro de combustible Filtre à carburant		
63	0109710	2	Tie cable Kabelbinder	Fijación Attache		
68	0129791	1	Decal-Diesel Aufkleber-Diesel	Calcomanía-Diesel Autocollant-Diesel		
69	0209682	1	T-piece T-Stück	Pieza T T-pièce		
70	0071130	1	O-ring O-Ring	Anillo-O Bague-O	7,5 x 10,5 x 1,5	
71	0209968	1	Fuel pipe cpl. Kraftstoffleitung kpl.	Pipa del combustible cpl. Pipe du combustible cpl.		
72	5000054291	1	Spacer Abstandsstück	Espaciador Entretoise		
73	5200022037	1	Clip Befestigung	Clip Clip		
74	5100039000	1	Bush Buchse	Buje Boîte		
75	0151456	1	Lock washer Federring	Arandela elástica Rondelle de ressort	6	DIN128
76	5100037722	1	Cheese head screw Zylinderschraube	Tornillo cilíndrico Vis à tête cylindrique		

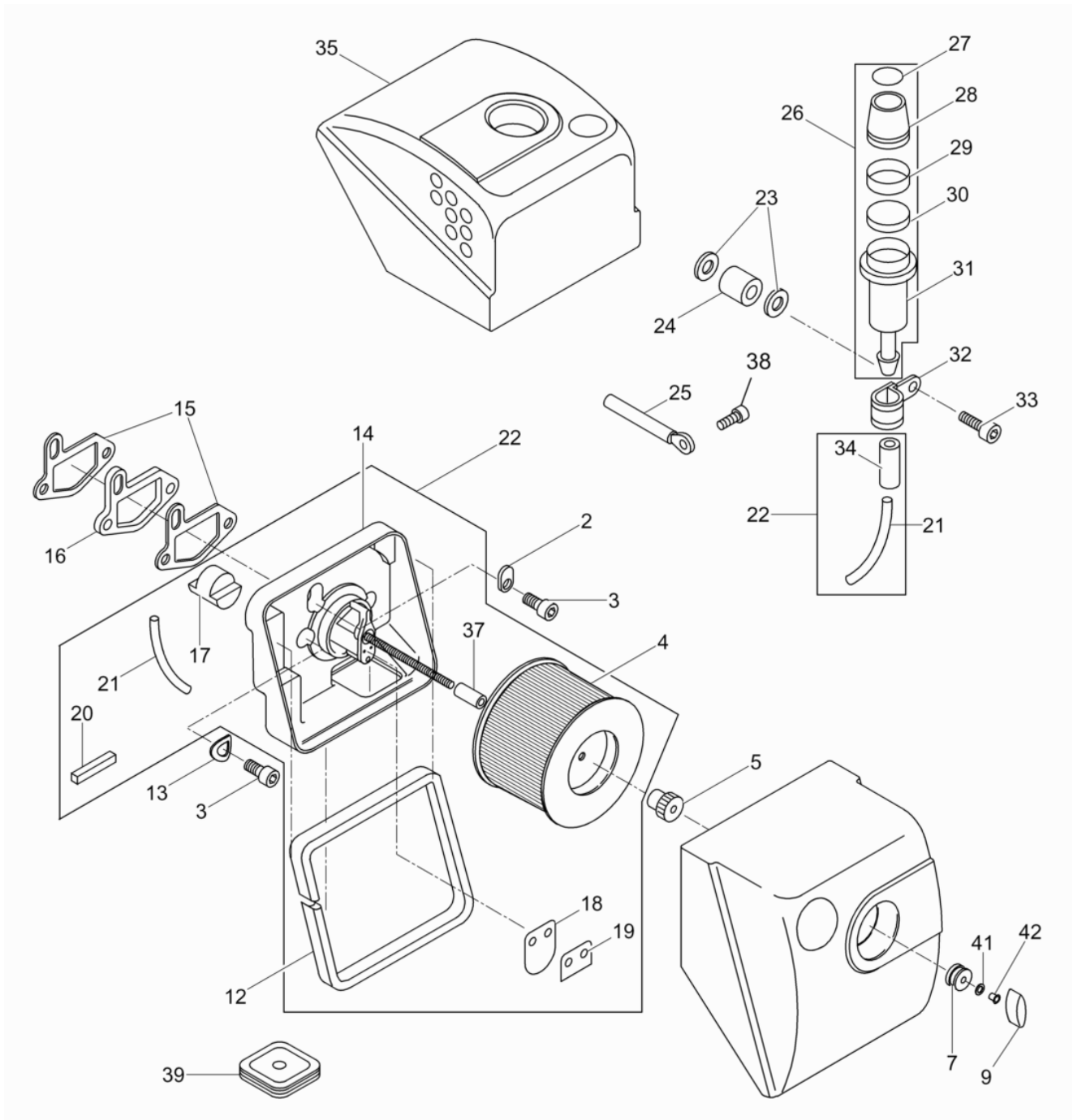

Ref. Pos.	Part No. Artikel Nr.	Qty. St.	Description Beschreibung	Descripción Description	Measurement./Abm.	Norm
					Torque/Drehm.	Sealant Schmierstoff
2	0108902	1	Washer Scheibe	Arandela Rondelle		
3	0151559	3	Cheese head screw Zylinderschraube	Tornillo cilíndrico Vis à tête cylindrique	M8 x 25	ISO4762
4	0108903	1	Air filter Filterelement	Filtro del aire Filtre à air		
5	0108904	1	Nut Rändelmutter	Tuerca Ecrou	M6	
7	0108906	1	Sleeve Dichtung	Manguito Douille		
9	0108907	1	Wing nut Flügelmutter	Tuerca mariposa Ecrou papillon	M6	
12	0129013	1	Seal Dichtleiste	Empaque Joint		
13	0013601	2	Spring washer Federscheibe	Arandela elástica Rondelle à ressort	A8	DIN137
15	0108897	2	Gasket Dichtung	Junta Joint		
16	0108898	1	Flange Isolierflansch	Brida Collerette		
17	0108899	1	Push-in plug Stopfen	Tapón Bouchon		
18	0151528	1	Cover Ventilplatte	Tapa Couvercle		
19	0151531	1	Cover Ventilplatte	Tapa Couvercle		
20	0151532	1	Seal Dichtleiste	Empaque Joint	14 x 9 x 30	
21	0151536	1	Hose Schlauch	Manguera Tuyau	2 x 4 x 135	
22	0109709	1	Filter housing Filterkonsole kpl.	Carcasa filtro Filtre		
23	0107823	2	Cup spring Tellerfeder	Resorte de platillo Ressort belleville	6,4	
24	0108852	1	Spacer tube Hülse	Tubo Tube	6,5 x 12 x 18	
25	0097590	1	Clamp Schelle	Abrazadera Agrafe		
26	0109711	1	Maintenance indicator cpl. Wartungsanzeige kpl.	Indicador de mantenimiento Indicateur dentretien		
27	0104463	1	Information sign Hinweisschild	Placa indicadora Plaque		
28	0099808	1	Rubber cap Gummikappe	Capuchón de goma Chape de caoutchouc		
29	0104462	1	Rubber ring Gummiring	Anillo de goma Bague en caoutchouc		
30	0109714	1	Filter disk Filterscheibe	Disco filtrante Rondelle de filtre		
31	0099949	1	Adaptor Adapter	Adaptador Adaptateur		

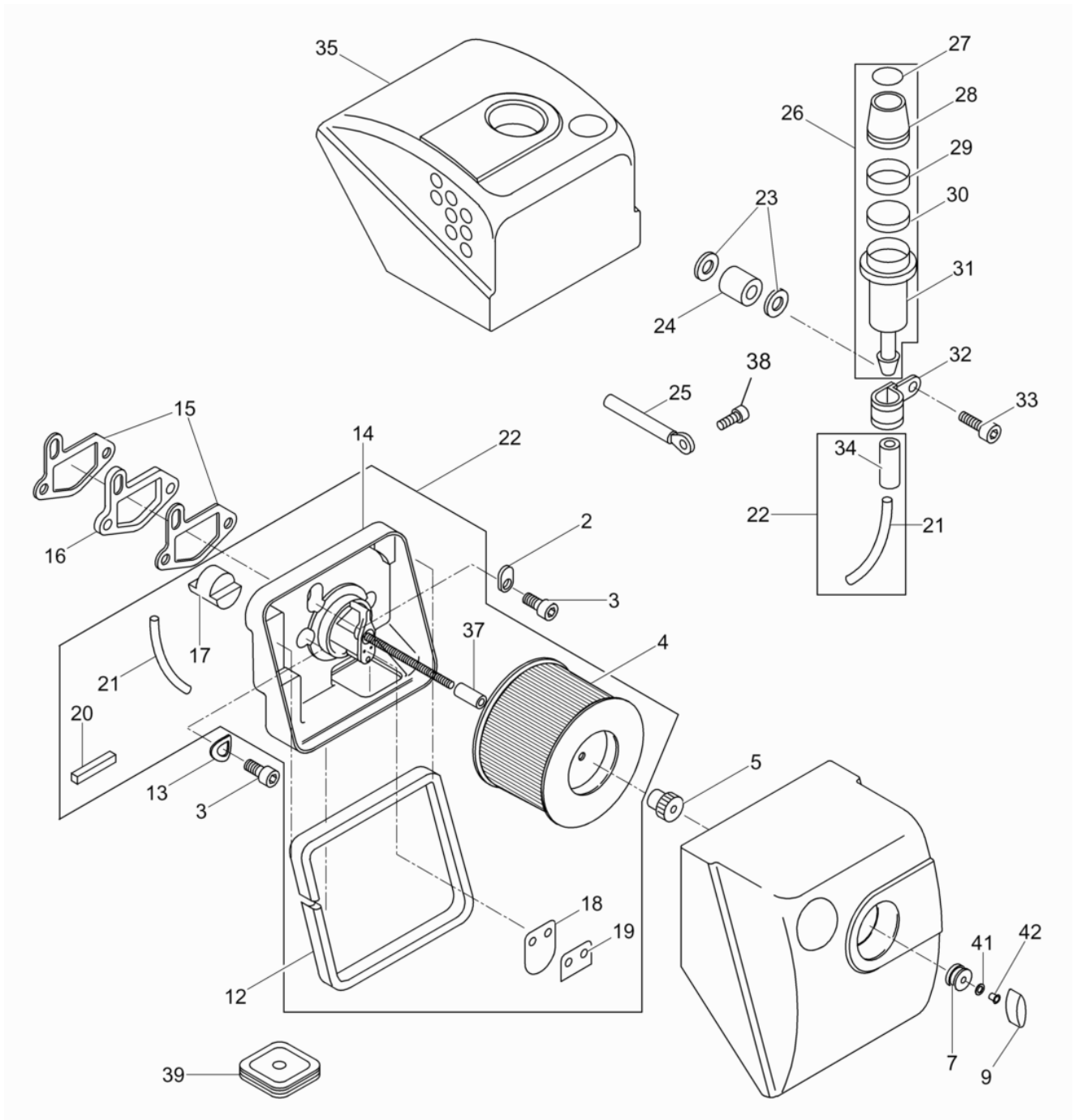

Ref. Pos.	Part No. Artikel Nr.	Qty. St.	Description Beschreibung	Descripción Description	Measurement./Abm.	Norm
					Torque/Drehm.	Sealant Schmierstoff
32	0095050	1	Pipe clamp Rohrschelle	Abrazadera Collier pour tuyau		
33	0129002	1	Cheese head screw Zylinderschraube	Tornillo cilíndrico Vis à tête cylindrique	M6 x 35	ISO4762
34	0226319	1	Fuel hose Kraftstoffleitung	Manguera de combustible Tuyau à essence	3,5x140	
35	0209970	1	Air filter cover Luftfilterdeckel	Tapa filtro de aire Couvercle filtre à air		
38	0129016	1	Cheese head screw Zylinderschraube	Tornillo cilíndrico Vis à tête cylindrique	M6 x 12	ISO4762
39	0202308	1	Fuel tank cap Verschlußdeckel	Tapa del tanque de combustible Chapeau de réservoir à essence		
41	0215786	1	Shim Ring Passscheibe	Arandela de Ajuste Disque D'Ajustage	9x15x1	
42	0215787	1	Insert Rohrriet	Inserto Insertion	A 9x0,5x12	

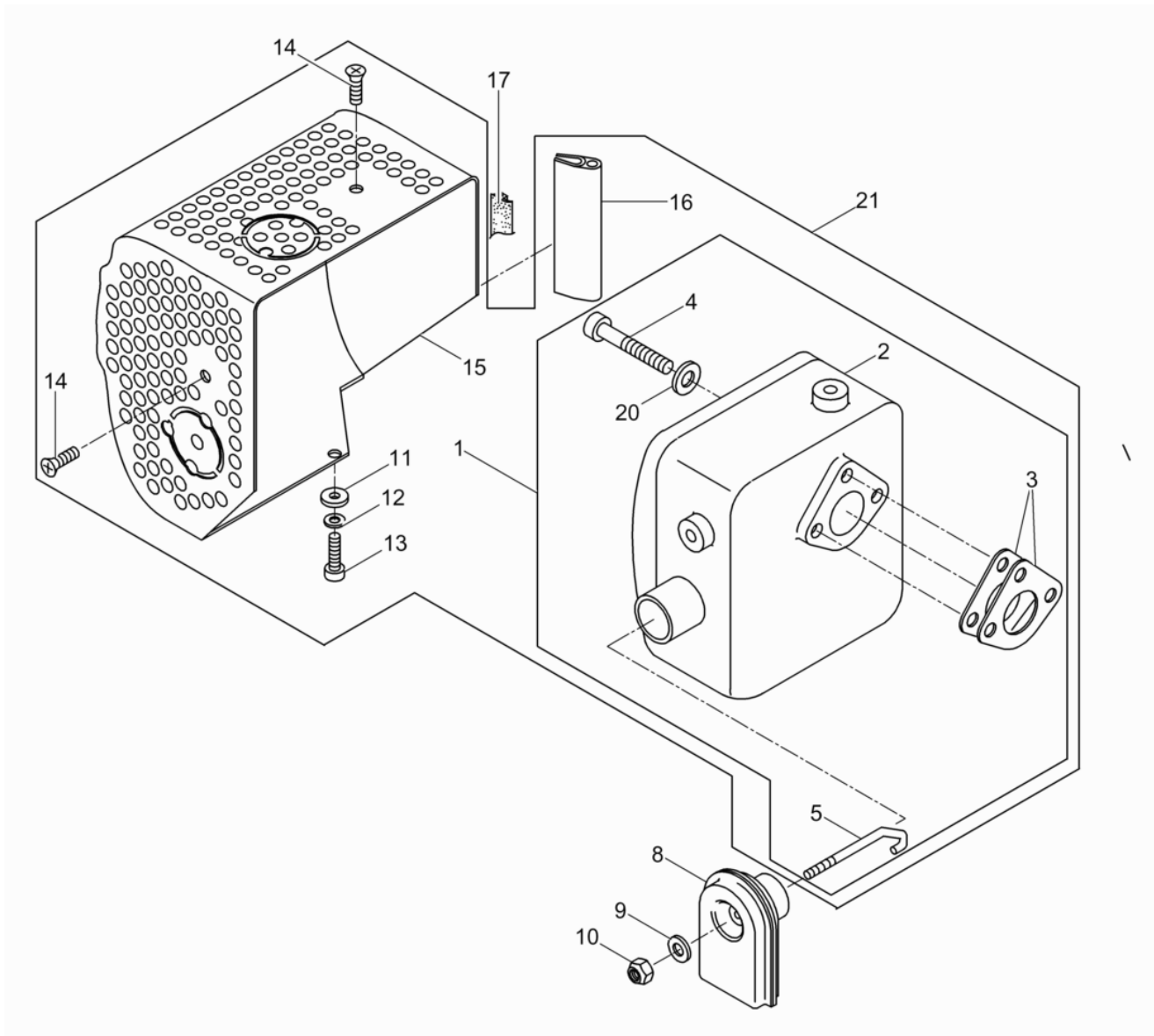

Ref. Pos.	Part No. Artikel Nr.	Qty. St.	Description Beschreibung	Descripción Description	Measurement/Abm.	Norm
					Torque/Drehm.	Sealant Schmierstoff
1	0214968	1	Exhaust Silencer Abgasdämpfer	Silenciador Silencieux		
3	0215773	1	Gasket Dichtungspaket	Junta Joint		
4	0202457	3	Hexagon socket head screw Innensechskantschraube	Tornillo a seis lados huecos Vis à six pans creux	M8 x 25	
5	0206629	1	Threaded bolt Gewindebolzen	Perno roscado Boulon fileté	M6	
8	0129032	1	Exhaust Manifold With Screen Auspuffkrümmer mit Sieb	Codo de Escape Con Filtro Collecteur D'Échappement Avec		
9	0151324	1	Washer Scheibe	Arandela Rondelle	6.4	
10	0108793	1	Hexagon nut Sechskantmutter	Tuerca hexagonal Écrou hexagonal	VM6	DIN980
11	0107401	1	Washer Scheibe	Arandela Rondelle	6.4	
12	0151456	1	Lock washer Federring	Arandela elástica Rondelle de ressort	6	DIN128
13	0202338	1	Hexagonal head cap screw Sechskantschraube	Tornillo hexagonal Vis à tête hexagonale	M6 x 16	DIN933
14	0151387	2	Countersunk screw Senkschraube	Tornillo avellanado Vis noyée	M6 x 12 14Nm/10ft.lbs	ISO10642
15	0214969	1	Contact safety device Berührungsschutz	Dispositivo de protección Grille de protection		
16	0109726	1	Seal Kantenschutz	Empaque Joint	65	
17	0129512	1	Seal Dichtleiste	Empaque Joint	33	
20	0151218	3	Lock washer Federring	Arandela elástica Rondelle de ressort	8	
21	0214967	1	Exhaust Silencer Kit Abgasdämpfer Satz	Silenciador Juego Silencieux Jeu		

Governor Bowden Cable
Drehzahlverstellung Bowdenzug
Regulador de Revoluciones Cable Bowden
Régulateur de Régime Câble

DPS 1850H
Asphalt

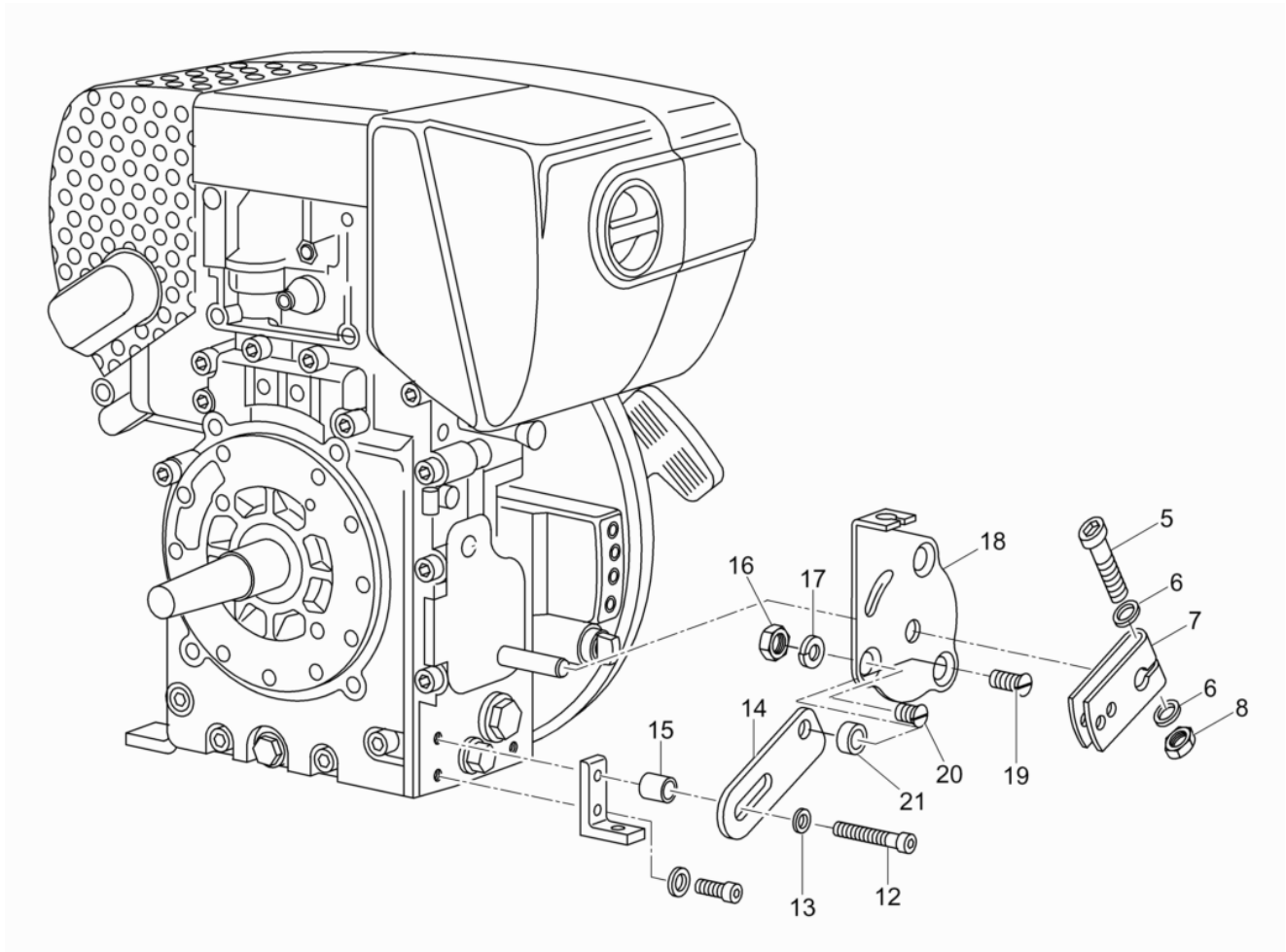

Ref. Pos.	Part No. Artikel Nr.	Qty. St.	Description Beschreibung	Descripción Description	Measurement/Abm.	Norm
					Torque/Drehm.	Sealant Schmierstoff
5	0209886	1	Cheese head screw Zylinderschraube	Tornillo cilíndrico Vis à tête cylindrique	M 5x30	
6	0129517	2	Washer Scheibe	Arandela Rondelle	A5,3	ISO7089
7	0109717	1	Lever Hebel	Palanca Levier		
8	0129020	1	Locknut Sechskantmutter	Contratuerca Contre-écrou	M5	ISO4032
12	0126979	1	Cheese head screw Zylinderschraube	Tornillo cilíndrico Vis à tête cylindrique	M8 x 60	DIN912
13	0151553	1	Washer Scheibe	Arandela Rondelle	B8,4	ISO7089
14	0126980	1	Plate Lasche	Eclisa Attache		
15	0107843	1	Sleeve Hülse	Manguito Douille		
16	0129021	1	Locknut Sechskantmutter	Contratuerca Contre-écrou	VM6	
17	0151218	1	Lock washer Federring	Arandela elástica Rondelle de ressort	8	
18	0209887	1	Console Konsole	Consola Console		
19	0126982	1	Countersunk screw Senkschraube	Tornillo avellanado Vis noyée	M6 x 20 14Nm/10ft.lbs	ISO10642
20	0129022	1	Countersunk screw Senkschraube	Tornillo avellanado Vis noyée	M6 x 16 14Nm/10ft.lbs	ISO10642
21	0063384	1	Adaptor Zwischenstück	Pieza intermedia Pièce intermédiaire		

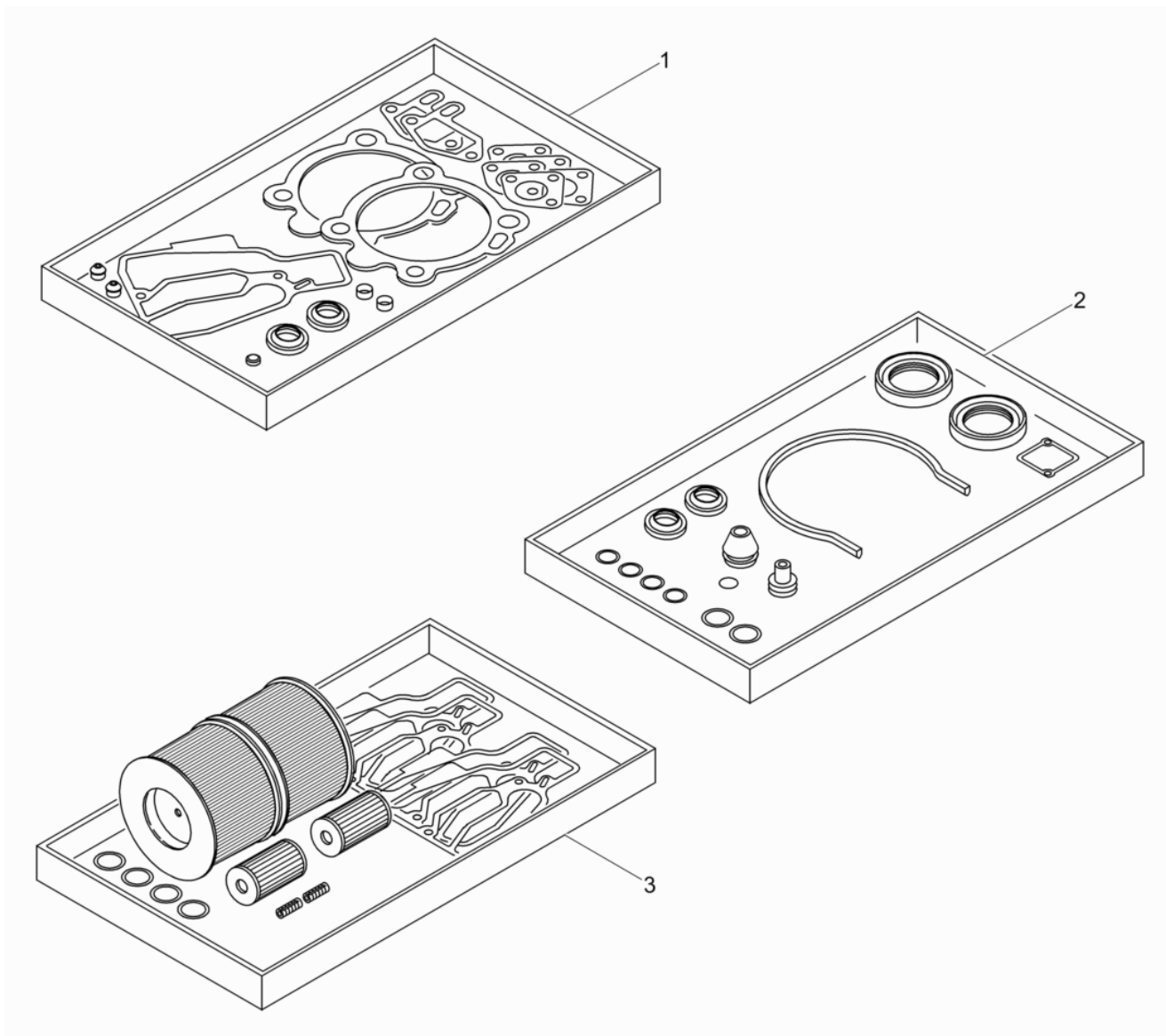

Ref. Pos.	Part No. Artikel Nr.	Qty. St.	Description Beschreibung	Descripción Description	Measurement./Abm.	Norm
					Torque/Drehm.	Sealant Schmierstoff
1	0108697	1	Set-gasket, cylinder head Dichtungssatz-Zylinderkopf	Juego de juntas-culata de cilindro Jeu de joints-culasse de		
2	0108698	1	Gasket set Dichtungssatz	Juego de juntas Jeu de joints		
3	0129498	1	Maintenance set Wartungssatz	Juego para mantenimiento Jeu d'entretien		



**WACKER
NEUSON**

**Accessories
Zubehör
Accesorios
Accessoires**

Urethane Pad Kit cpl. PGV 1850
Gleitvorrichtung kpl. PGV 1850
Placa de Deslizamiento cpl. PGV 1850
Jeu de Tapis en Polyuréthane

DPS 1850H
Asphalt

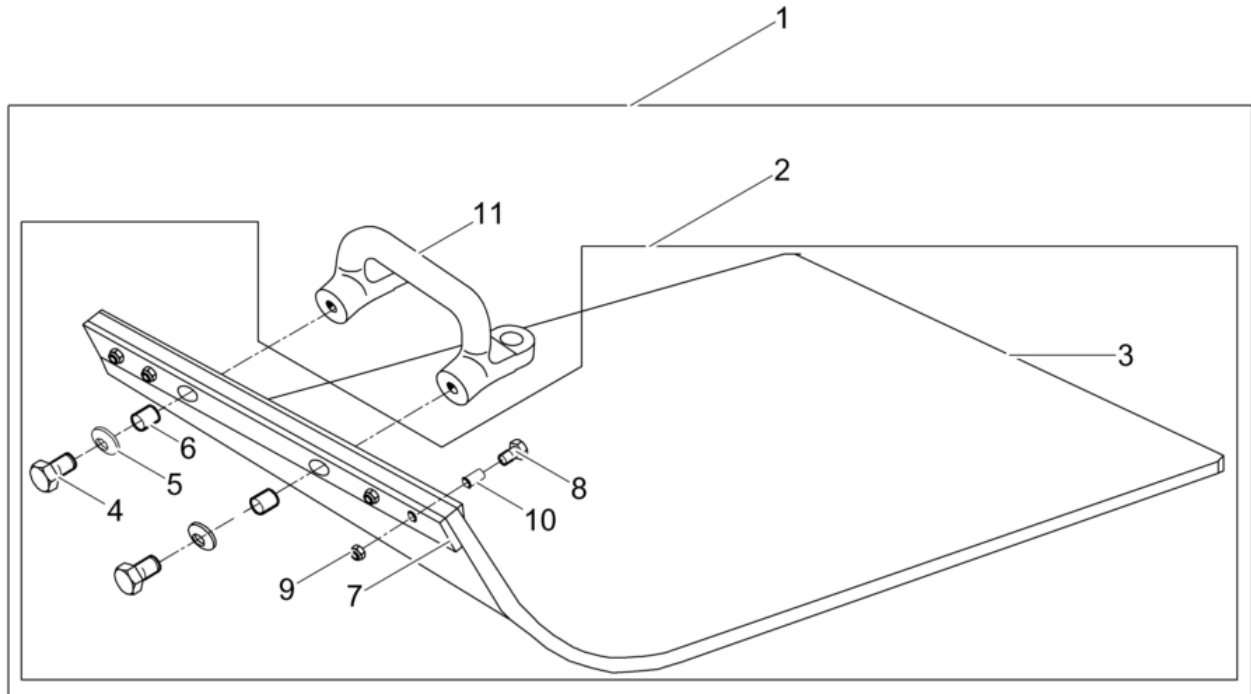

DPS 1850H
Asphalt

Urethane Pad Kit cpl. PGV 1850
Gleitvorrichtung kpl. PGV 1850
Placa de Deslizamiento cpl. PGV 1850
Jeu de Tapis en Polyuréthane

Ref. Pos.	Part No. Artikel Nr.	Qty. St.	Description Beschreibung	Descripción Description	Measurem./Abm.	Norm
					Torque/Drehm.	Sealant Schmierstoff
1	0201905	1	Urethane Pad Kit PGV 1850 Gleitvorrichtung	Placa de Deslizamiento PGV 1850 Jeu de Tapis en Polyuréthane		
2	0069095	1	Urethane Pad Kit PGV 50 Gleitvorrichtung	Placa de Deslizamiento PGV 50 Jeu de Tapis en Polyuréthane		
3	0047584	1	urethane plate Kunststoffplatte	Juego de lamina de uretano Dispositif de glissement		
4	0011421	2	Hexagonal head cap screw Sechskantschraube	Tornillo hexagonal Vis à tête hexagonale	M12 x 40 86Nm/63ft.lbs	DIN933
5	0031565	2	Lockwasher Spannscheibe	Arandela elástica Rondelle de ressort	12	DIN6796
6	0047578	2	Bushing Buchse	Buje Douille		
7	0047574	2	Fitting Befestigungsleiste	Listón de sujeción Listeau de fixation		
8	0011456	4	Hexagonal head cap screw Sechskantschraube	Tornillo hexagonal Vis à tête hexagonale	25Nm/18ft.lbs	
9	0033356	4	Hexagon nut Sechskantmutter	Tuerca hexagonal Écrou hexagonal		
10	0047577	4	Bushing Buchse	Buje Douille		
11	0069893	1	Handle Handgriff	Empuñadura Poignée		

Handle complete
Handgriff kpl.
Manija compl.
Poignée compl.

DPS 1850H
Asphalt

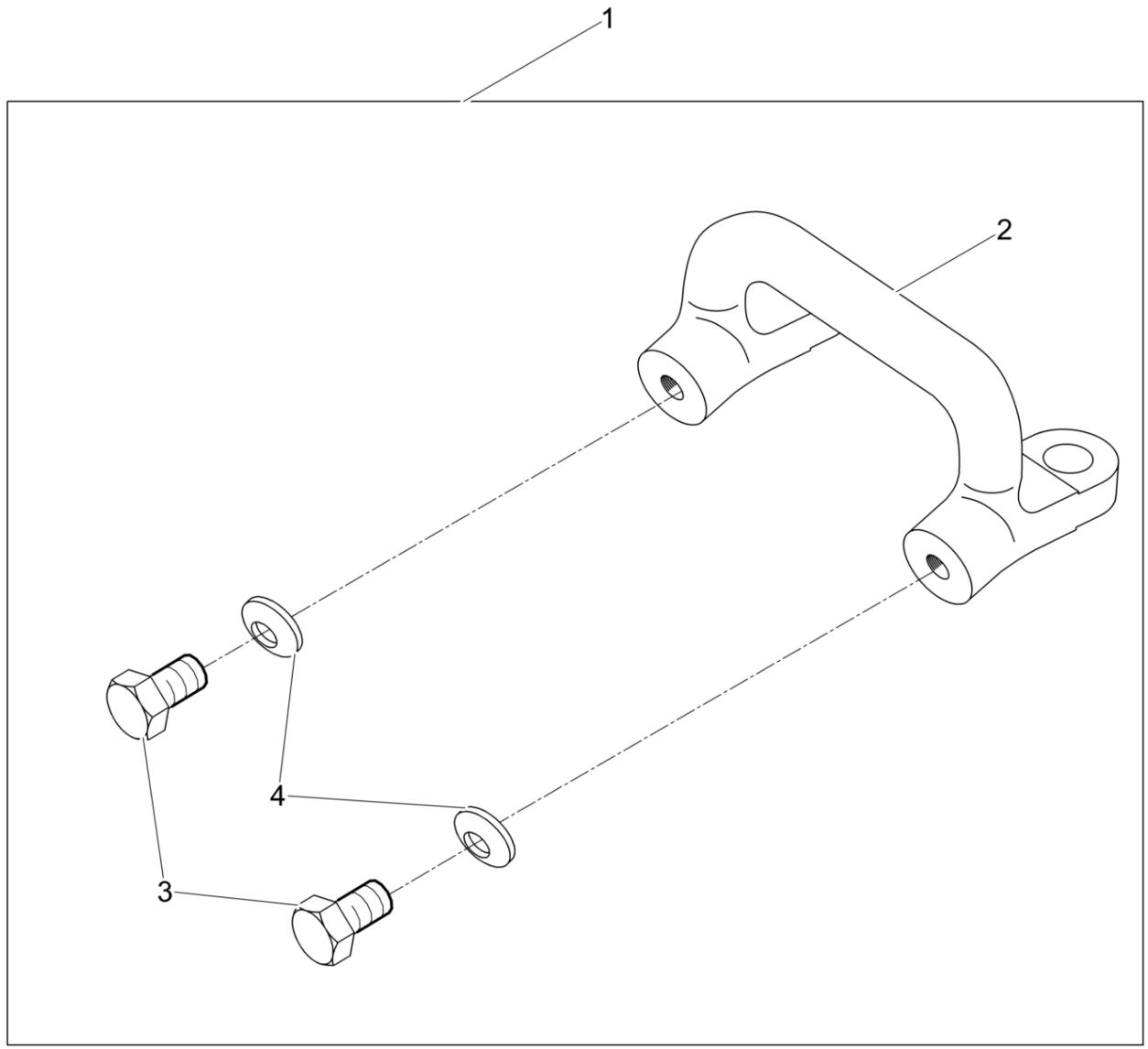

**DPS 1850H
Asphalt**

**Handle complete
Handgriff kpl.
Manija compl.
Poignée compl.**

Ref. Pos.	Part No. Artikel Nr.	Qty. St.	Description Beschreibung	Descripción Description	Measurement./Abm.	Norm
					Torque/Drehm.	Sealant Schmierstoff
1	0204531	1	Handle complete Handgriff kpl.	Manija compl. Poignée compl.		
2	0069893	1	Handle Handgriff	Empuñadura Poignée		
3	0011421	2	Hexagonal head cap screw Sechskantschraube	Tornillo hexagonal Vis à tête hexagonale	M12 x 40 86Nm/63ft.lbs	DIN933
4	0031565	2	Lockwasher Spannscheibe	Arandela elástica Rondelle de ressort	12	DIN6796



**WACKER
NEUSON**