



**WACKER
NEUSON**

0006590	105
04.2013	

**Modular Internal Vibrators
Modulare Innenvibratoren
Vibradores Internos Modulares
Vibrateurs Internes à Transmis**

M3000/230/RFI

**Parts Book
Ersatzteile
Lista de Repuestos
Liste de Pièces de Rechange**

www.wackerneuson.com

A nameplate listing the Model Number, Item Number, Revision, and Serial Number is attached to each unit. Please record the information found on this plate so it will be available should the nameplate become lost or damaged. When ordering parts or requesting service information, you will always be asked to specify the model, item number, revision number, and serial number of the unit.

Ein Typenschild mit Typ, Artikelnummer, Version und Maschinen-Nummer ist an jedem Gerät angebracht. Die Daten von diesem Schild bitte notieren, damit sie auch bei Verlust oder Beschädigung des Schildes noch vorhanden sind. Der Typ, die Artikel-Nummer, die Versions- Nummer und die Maschinen-Nummer sind bei der Ersatzteilbestellung oder Nachfragen bezüglich Service-Informationen stets erforderlich.

Una placa de identificación con el modelo, número de referencia, nivel de revisión y número de serie ha sido añadida en cada máquina. Favor de anotar los datos en la placa en caso de que la placa de identificación sea destruida o perdida. En todos los pedidos para repuestos necesita siempre el modelo, el número de referencia, el nivel de revisión y el número de serie de la máquina en cuestión.

Une plaque signalétique mentionnant le modèle, le numéro de référence, le niveau de révision et le numéro de série est fixée sur chaque machine. Veuillez noter les informations relevées sur cette plaque de façon à ce qu'elles soient toujours disponibles si la plaque signalétique venait à être perdue ou endommagée. Lorsque vous commandez des pièces détachées ou vous sollicitez des informations après-vente, on vous demandera toujours de préciser le modèle, le numéro de référence, le niveau de révision et le numéro de série de la machine.

***My machine's numbers are / Die Nummern meines Gerätes sind /
 Los números de mi máquina son / Les numéros de ma machine son :***



Part Numbers appearing in boldface type are recommended spare parts. This means that these parts are subject to wear under normal operating conditions and may require periodic service or replacement. It is recommended that these items be stocked to meet the expected service requirements of this model. Actual stocking quantities of these and other parts used in more extensive repairs will depend on the service practices of each customer.

Bei den in den Ersatzteillisten fettgedruckten Nummern handelt es sich um empfohlene Ersatzteile. Dies bedeutet, daß diese Teile bei normalen Anwendungsbedingungen natürlicher Abnutzung ausgesetzt sind und gelegentlich ersetzt oder überarbeitet werden müssen. Es wird geraten, diese Teile auf Lager bereit zu haben, um für Service-Arbeiten an diesem Gerät vorbereitet zu sein. Lagerbestände für diese und andere Teile, welche für ausgiebigere Reparaturarbeiten benötigt werden, können je nach Service-Gewohnheiten der einzelnen Kunden variieren.

Los números de partes en negritas en las Listas Ilustradas de Partes son los repuestos recomendados, ésto quiere decir que estas partes se desgastarán bajo circunstancias de funcionamiento normales y pueden requerir servicio periódico o su reemplazo. Se recomienda que el cliente mantenga un abastecimiento adecuado de estas partes para poder satisfacer la demanda requerida por el servicio a la máquina. La cantidad de repuestos que el cliente necesitará para reparaciones dependerá de la póliza de servicio de cada cliente.

Les numéros de pièces imprimés en caractères gras dans les Listes des Pièces Détachées de ce manuel sont les pièces détachées recommandées par la Wacker. Cela veut dire que ces pièces sont sujettes à usure dans des conditions de travail normales et peuvent nécessiter de l'entretien ou leur remplacement. Nous recommandons que vous disposez d'un stock de ces pièces pour pouvoir satisfaire la demande d'entretien de cette machine. Le client doit décider lui-même de la quantité exacte de pièces de rechange qu'il disposera dans ses stocks.

Drive Engine cpl. Antriebsmotor kpl. Motor de Accionamiento cpl. Moteur de Comande cpl.	8
Housing cpl. Gehäuse kpl. Carcasa cpl. Carter cpl.	10
Motor Armature Set Statorsatz Juego de Rotor Jeu de Rotor	12
Motor Armature Set 230V Rotorsatz 230V Juego de Rotor 230V Jeu de Rotor 230V	14
Detent Pin Vorsteckstift Pasador Goupille	16
Power supply cable cpl. Zuleitungskabel kpl. Cable de alimentación cpl. Câble d'amenée cpl.	18
Labels Aufkleber Calcomanías Autocollants	20
Accessories Zubehör Accesorios Accessoires	23
Flex Shafts SM 1E Biegewelle SM 1E Ejes Flexibles SM 1E Transmission Flexible SM 1E	24
Flex Shafts SM 2E Biegewelle SM 2E Ejes Flexibles SM 2E Transmission Flexible SM 2E	26
Flex Shafts SM 4E Biegewelle SM 4E Ejes Flexibles SM 4E Transmission Flexible SM 4E	28
Flex Shafts SM 0S Biegewelle SM 0S Ejes Flexibles SM 0S Transmission Flexible SM 0S	30
Flex Shafts SM 1S Biegewelle SM 1S Ejes Flexibles SM 1S Transmission Flexible SM 1S	32
Flex Shafts SM 2S Biegewelle SM 2S Ejes Flexibles SM 2S Transmission Flexible SM 2S	34

Indice**Table des matières**

Flex Shafts SM 3S Biegewelle SM 3S Ejes Flexibles SM 3S Transmission Flexible SM 3S	36
Flex Shafts SM 4S Biegewelle SM 4S Ejes Flexibles SM 4S Transmission Flexible SM 4S	38
Flex Shafts SM 5S Biegewelle SM 5S Ejes Flexibles SM 5S Transmission Flexible SM 5S	40
Flex Shafts SM 7S Biegewelle SM 7S Ejes Flexibles SM 7S Transmission Flexible SM 7S	42
Flex Shafts SM 9S Biegewelle SM 9S Ejes Flexibles SM 9S Transmission Flexible SM 9S	44
SS Adaptor SS-Adapter Adaptador SS Adaptateur SS	46
Strap Tragegurt Correa Ruban	48
Service Service Servicio Service	53
Motor Housing asseembly Motorgehäusesatz Conjunto Carcasa de Motor Jeu-Carter de Moteur	54

Drive Engine cpl.
Antriebsmotor kpl.
Motor de Accionamiento cpl.
Moteur de Comande cpl.

M3000/230/RFI

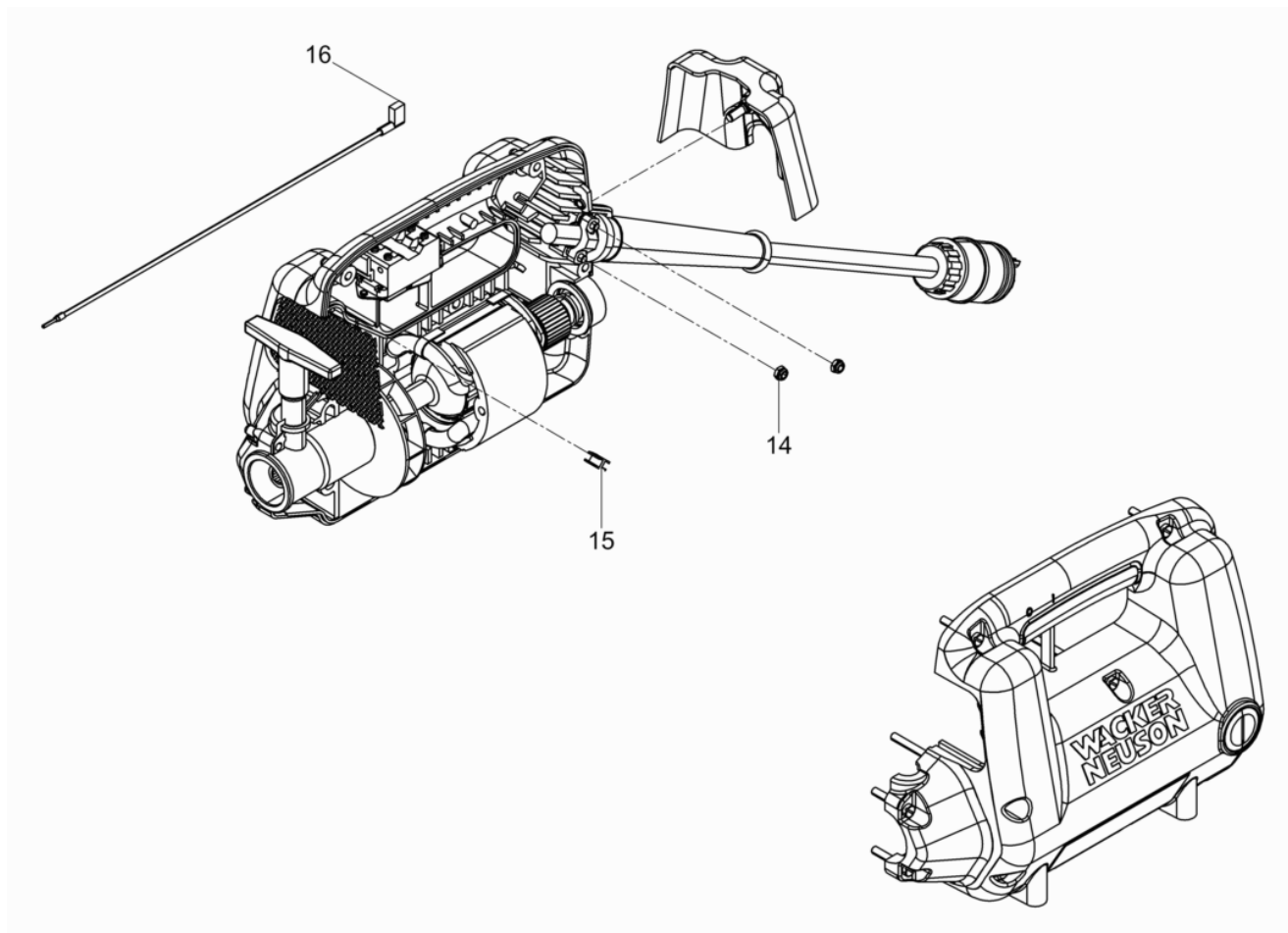

Ref. Pos.	Part No. Artikel Nr.	Qty. St.	Description Beschreibung	Descripción Description	Measurem./Abm.	Norm
					Torque/Drehm.	Sealant Schmierstoff
14	0010369	1	Hexagon nut Sechskantmutter	Tuerca hexagonal Écrou hexagonal	M5	DIN985
16	0083424	1	Rubber isolator Gummiformteil	Aisladora de goma Isolatuer en caoutchouc		
17	0219608	1	Supply line Verbindungsleitung	Línea de conexión Câble d'amenée		

Housing cpl.
Gehäuse kpl.
Carcasa cpl.
Carter cpl.

M3000/230/RFI

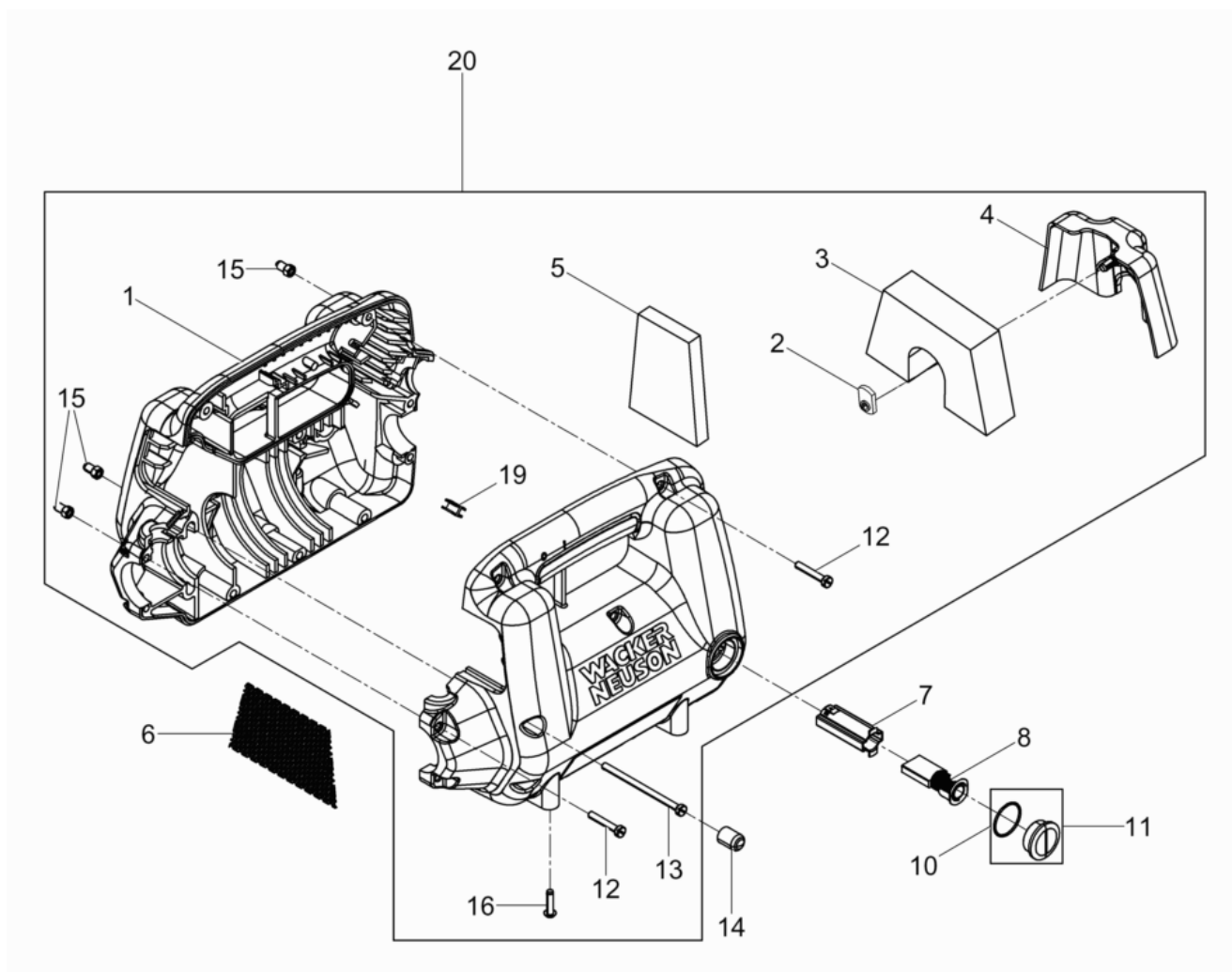

Ref. Pos.	Part No. Artikel Nr.	Qty. St.	Description Beschreibung	Descripción Description	Measurement./Abm.	Norm
					Torque/Drehm.	Sealant Schmierstoff
1	0219147	1	Housing assembly Gehäuse Satz	Conjunto Carcasa Jeu-Carter		UL
2	0083048	1	Nut Mutter	Tuerca Écrou		
3	0074527	1	Filter Filter	Filtro Filtre		
4	0083049	1	Cover cpl. Deckel kpl.	Tapa cpl. Couvercle cpl.		
5	0053950	2	Filter Filter	Filtro Filtre		
6	0053949	1	Ventilator protective grating Lüftungsgitter	Reja de ventilación Grille de protection d'aeration		
7	0054362	2	Carbon brush support Kohlebürstenhalter	Soporte de escobilla Support de balai de charbon		
8	0111145	2	Carbon Brush With Switch-Off Device Kohlebürste mit Abschaltung	Escobilla Autodesconectante Balai de Charbon Avec Dispositif de Coupure de Co.	230V	
10	0038765	2	O-Ring O-Ring	Anillo-O Joint torique	25 x 1,50	
11	0078697	2	Cap with O-Ring Kappe mit O-Ring	Tapa de Anillo-O Chapeau avec Joint torique		
12	0202539	6	Pan head screw Flachkopfschraube	Tornillo de cabeza plana Vis lentiforme	M5 x 30	
13	0202540	6	Pan head screw Flachkopfschraube	Tornillo de cabeza plana Vis lentiforme	M5 x 80	
14	0202124	2	Circular cap Rundkappe	Tapa Redondo Couvercle Coaxiale		
15	0081277	12	Cap nut Hutmutter	Tuerca caperuza Écrou à chapeau		
16	0202123	4	Grooved drive stud Halbrundkerbnagel	Remache redondo estriado Clou demi-rond à rainures	5 x 20	ISO8746

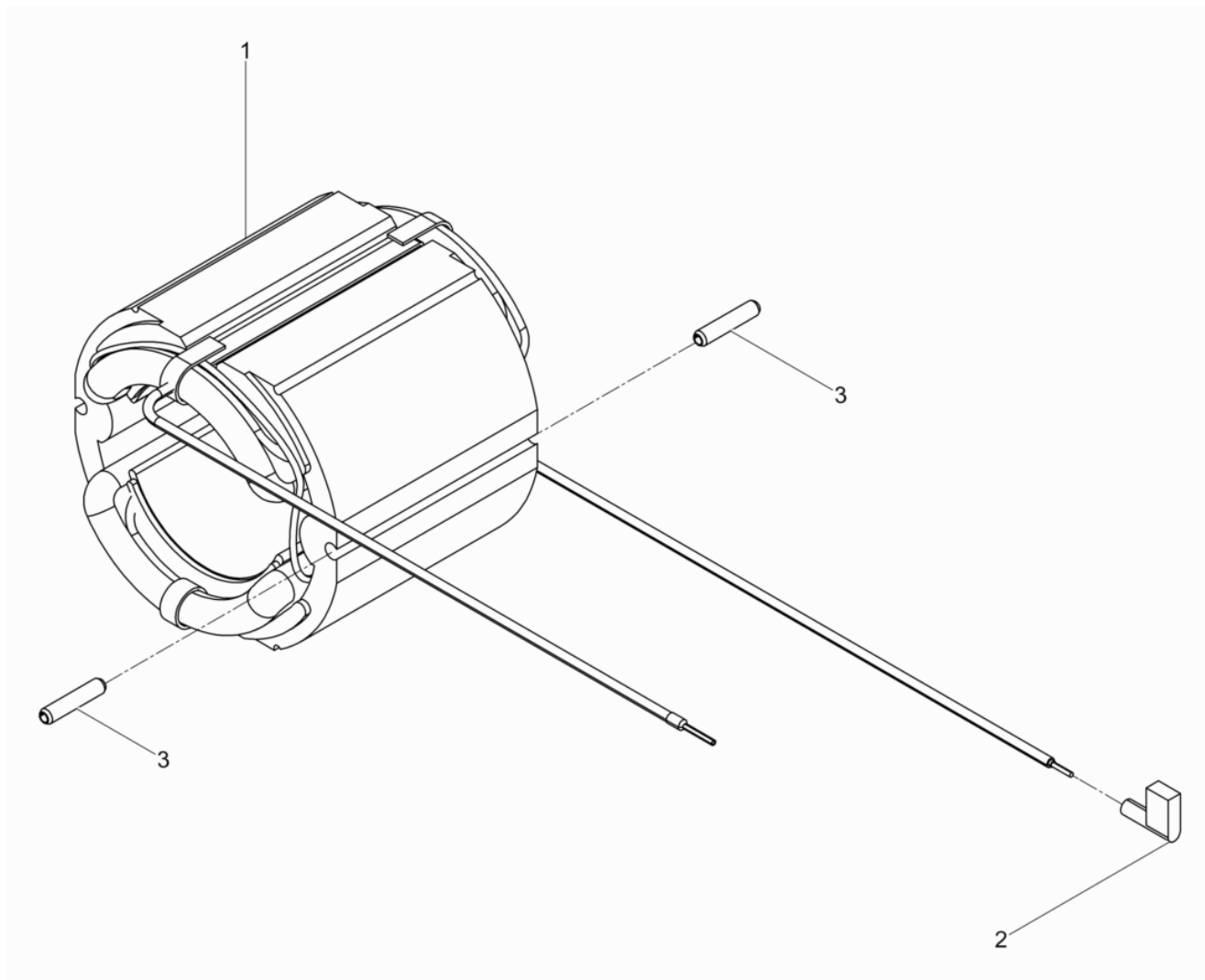

Ref. Pos.	Part No. Artikel Nr.	Qty. St.	Description Beschreibung	Descripción Description	Measurement./Abm.	Norm
					Torque/Drehm.	Sealant Schmierstoff
1	0074438	1	Stator Stator	Estator Stator	230V	
2	0077796	1	Terminal Fahnenschuh	Terminal de Cable Cosse de Câble		UL
3	0013592	2	Spring pin Spannstift	Pasador de sujeción Goupille élastique	5 x 24	

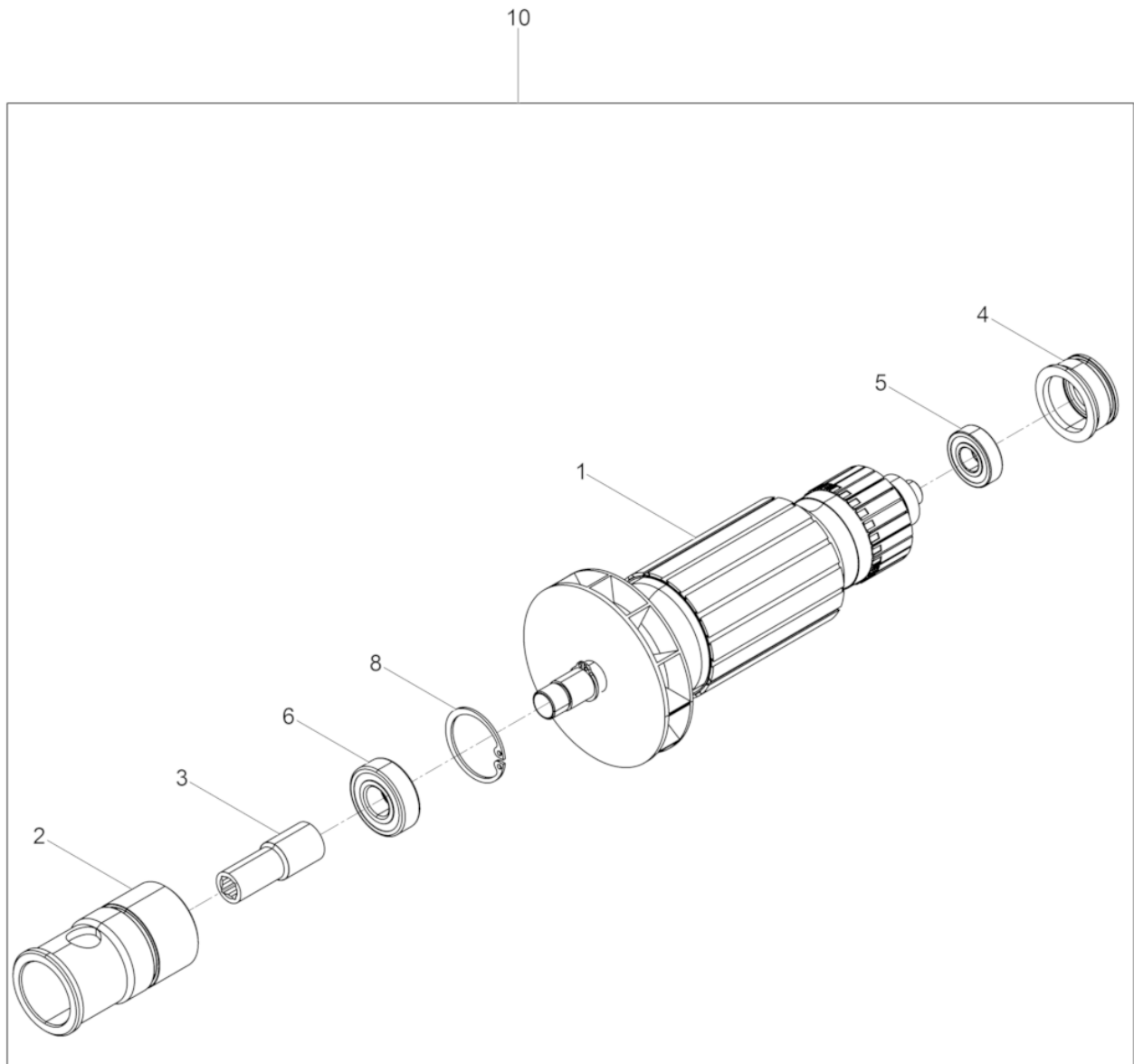

Ref. Pos.	Part No. Artikel Nr.	Qty. St.	Description Beschreibung	Descripción Description	Measurement./Abm.	Norm
					Torque/Drehm.	Sealant Schmierstoff
1	0074437	1	Rotor Rotor	Rotor Rotor	230V	
2	5100003637	1	Bearing bush Lagerbuchse	Casquillo del cojinete Bôte de roulement		
3	0053934	1	Adaptor Adapter	Adaptador Adaptateur		
4	5100003638	1	Bearing Cartridge Lagerhalter	Soporte de Cojinete Support de Palier		
5	0054358	1	Grooved ball bearing Rillenkugellager	Rodamiento de bolas Roulement à billes		
6	0054359	1	Grooved ball bearing Rillenkugellager	Rodamiento de bolas Roulement à billes		
8	0054242	1	Retaining ring Sicherungsring	Anillo de retención Bague d'arrêt	1,375 x 0,051 in	
10	0078495	1	Motor Armature Set Rotorsatz	Juego de Rotor Jeu de Rotor	230V	

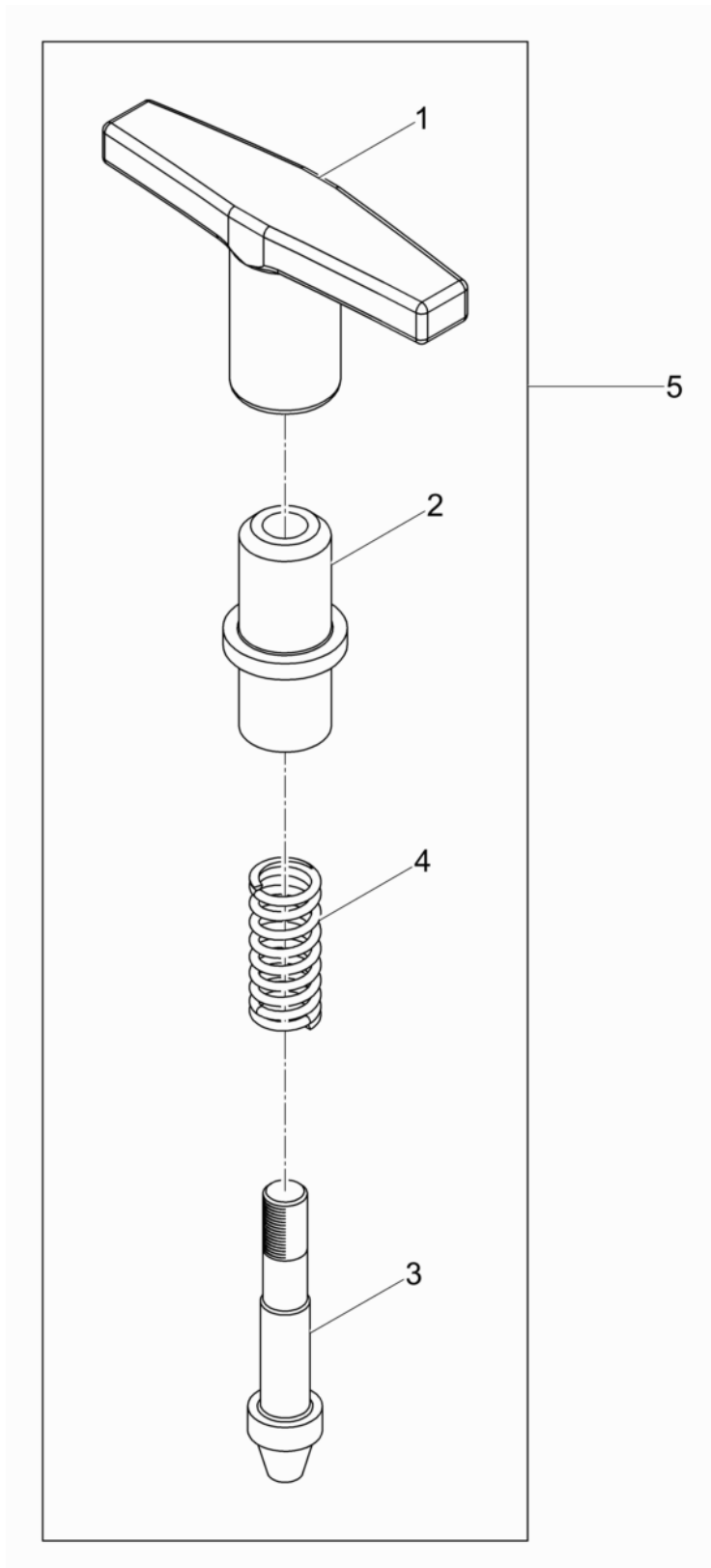

Ref. Pos.	Part No. Artikel Nr.	Qty. St.	Description Beschreibung	Descripción Description	Measurement./Abm.	Norm
					Torque/Drehm.	Sealant Schmierstoff
1	0218239	1	T-Knurled Nut T-Griffmutter	Tuerca T-Con estri'as Écrou T-Moleté		
2	0071183	1	Stud Housing Stiftgehäuse	Carcasa Espiga Carter Goupille		
3	0071184	1	Detent Pin Vorsteckstift	Pasador Goupille		
4	0071189	1	Compression spring Druckfeder	Resorte de compresión Ressort de pression		
5	0218242	1	Detent Pin cpl. Vorsteckstift kpl.	Pasador cpl. Goupille cpl.		

Power supply cable cpl.
Zuleitungskabel kpl.
Cable de alimentación cpl.
Câble d'amenée cpl.

M3000/230/RFI

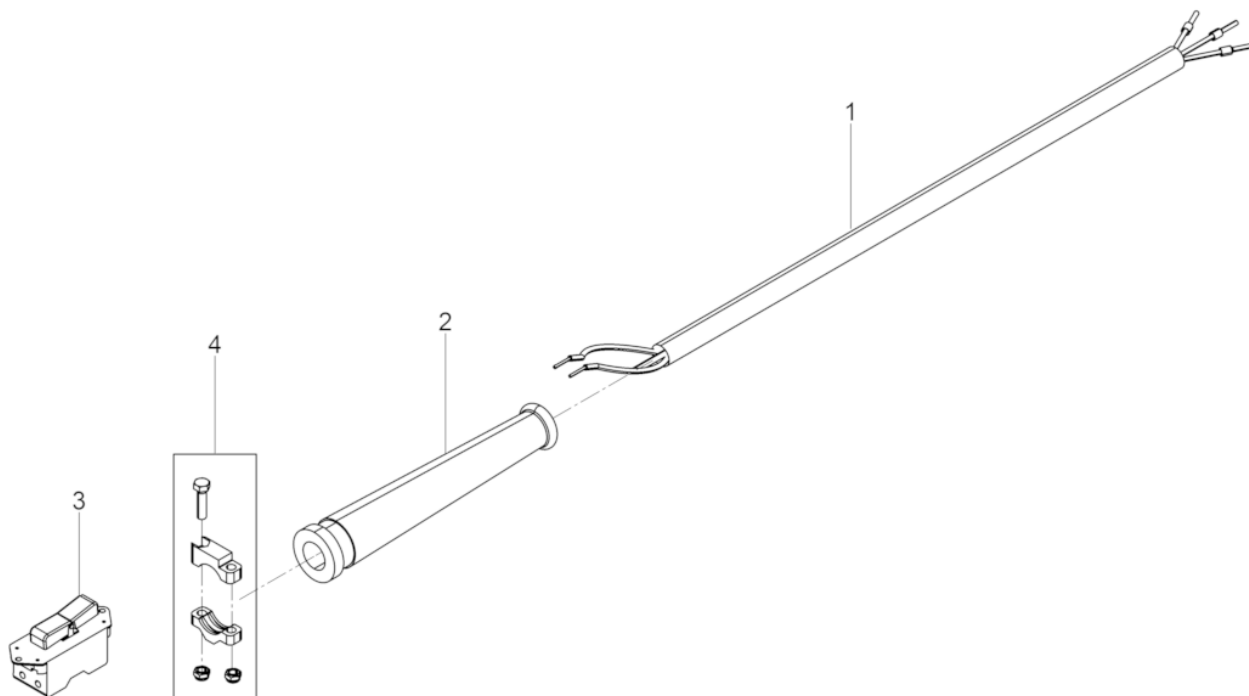

Ref. Pos.	Part No. Artikel Nr.	Qty. St.	Description Beschreibung	Descripción Description	Measurement./Abm.	Norm
					Torque/Drehm.	Sealant Schmierstoff
1	5100003788	1	Power supply cable Zuleitungskabel	Cable de alimentación Câble d'amenée		
2	0064243	1	Rubber funnel Gummitülle	Casquillo de goma Passe fil en caoutchouc		
3	0201472	1	Switch Geräteschalter	Interruptor Interrupteur		
4	0053952	1	Set-clamp Schellensatz	Juego de abrazaderas Jeu-agrafes		

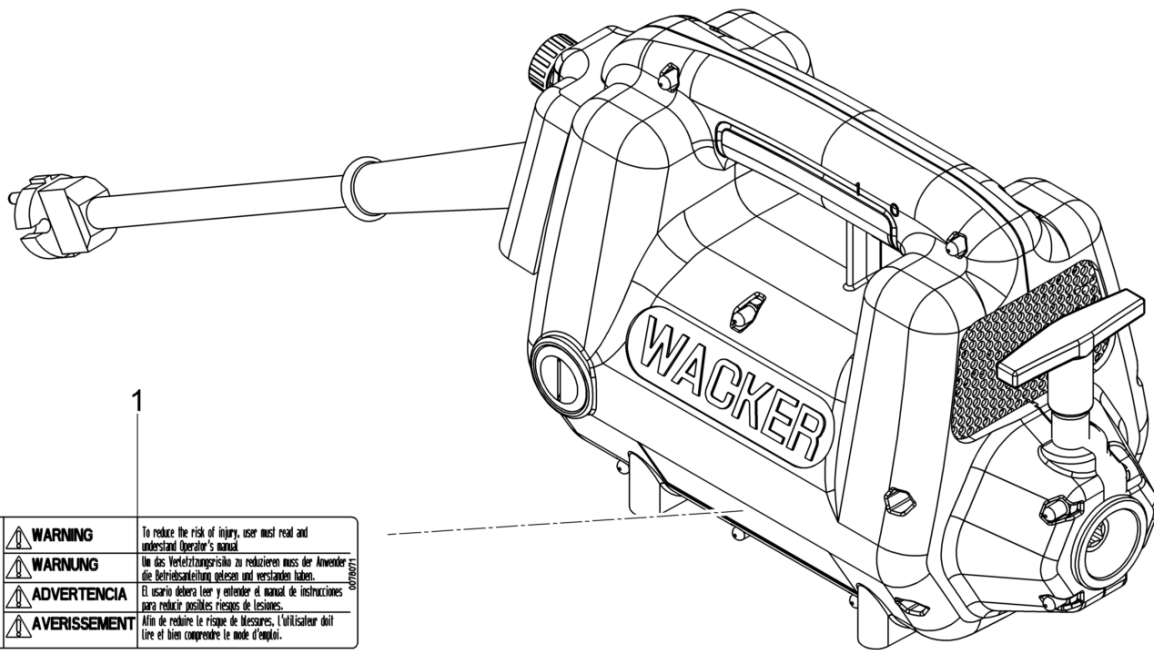

	WARNING	To reduce the risk of injury, user must read and understand Operator's manual.
	WARNUNG	Um das Verletzungsrisiko zu reduzieren muss der Anwender die Betriebsanleitung gelesen und verstanden haben.
	ADVERTENCIA	El usuario deberá leer y entender el manual de instrucciones para reducir posibles riesgos de lesiones.
	AVERTISSEMENT	Afin de réduire le risque de blessures, l'utilisateur doit lire et bien comprendre le mode d'emploi.

Ref. Pos.	Part No. Artikel Nr.	Qty. St.	Description Beschreibung	Descripción Description	Measurem./Abm.	Norm
					Torque/Drehm.	Sealant Schmierstoff
1	0078071	1	Information sign Hinweisschild	Placa indicadora Plaque		



**WACKER
NEUSON**

**Accessories
Zubehör
Accesorios
Accessoires**

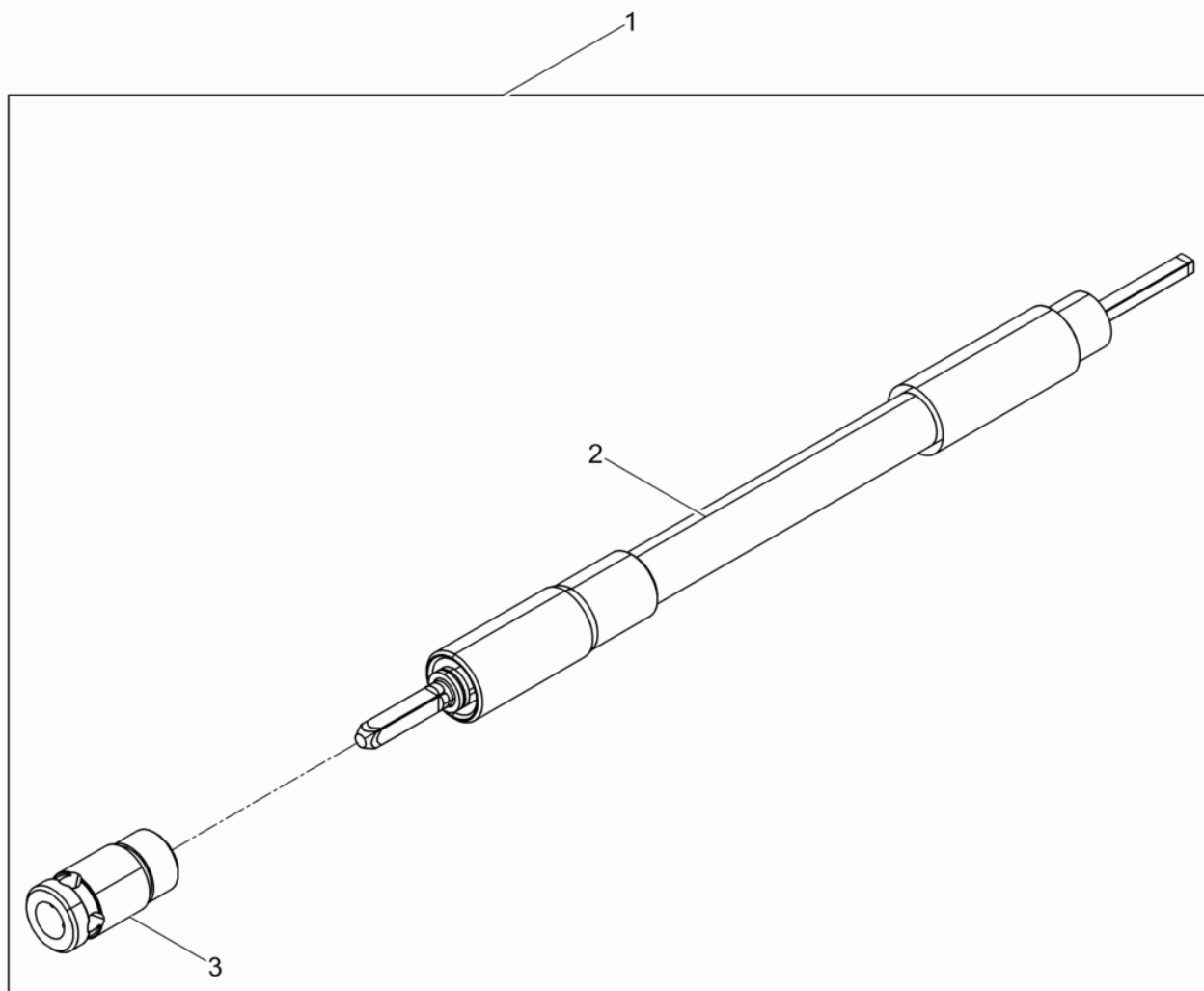

Ref. Pos.	Part No. Artikel Nr.	Qty. St.	Description Beschreibung	Descripción Description	Measurem./Abm.	Norm
					Torque/Drehm.	Sealant Schmierstoff
1	0086243	1	Flex Shafts SM 1E Biegewelle SM 1E	Ejes Flexibles SM 1E Transmission Flexible SM 1E		
2	0086246	1	Inner core Wellenseele	Alma Arbre à transmission flexible		
3	0071584	1	Coupling Kupplung	Acoplamiento Couplage		

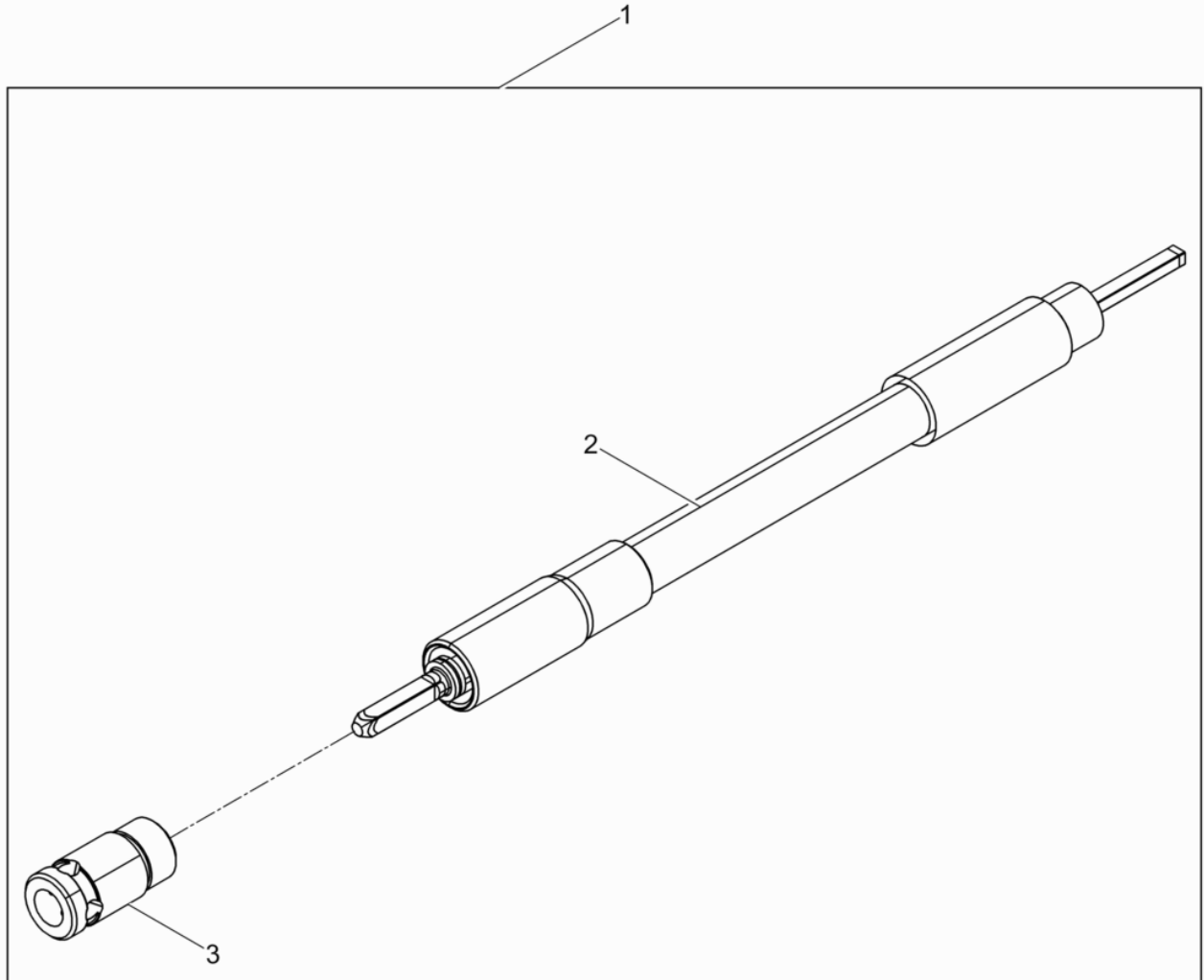

Ref. Pos.	Part No. Artikel Nr.	Qty. St.	Description Beschreibung	Descripción Description	Measurem./Abm.	Norm
					Torque/Drehm.	Sealant Schmierstoff
1	0086244	1	Flex Shafts SM 2E Biegewelle SM 2E	Ejes Flexibles SM 2E Transmission Flexible SM 2E		
2	0086247	1	Inner core Wellenseele	Alma Arbre à transmission flexible		
3	0071584	1	Coupling Kupplung	Acoplamiento Couplage		

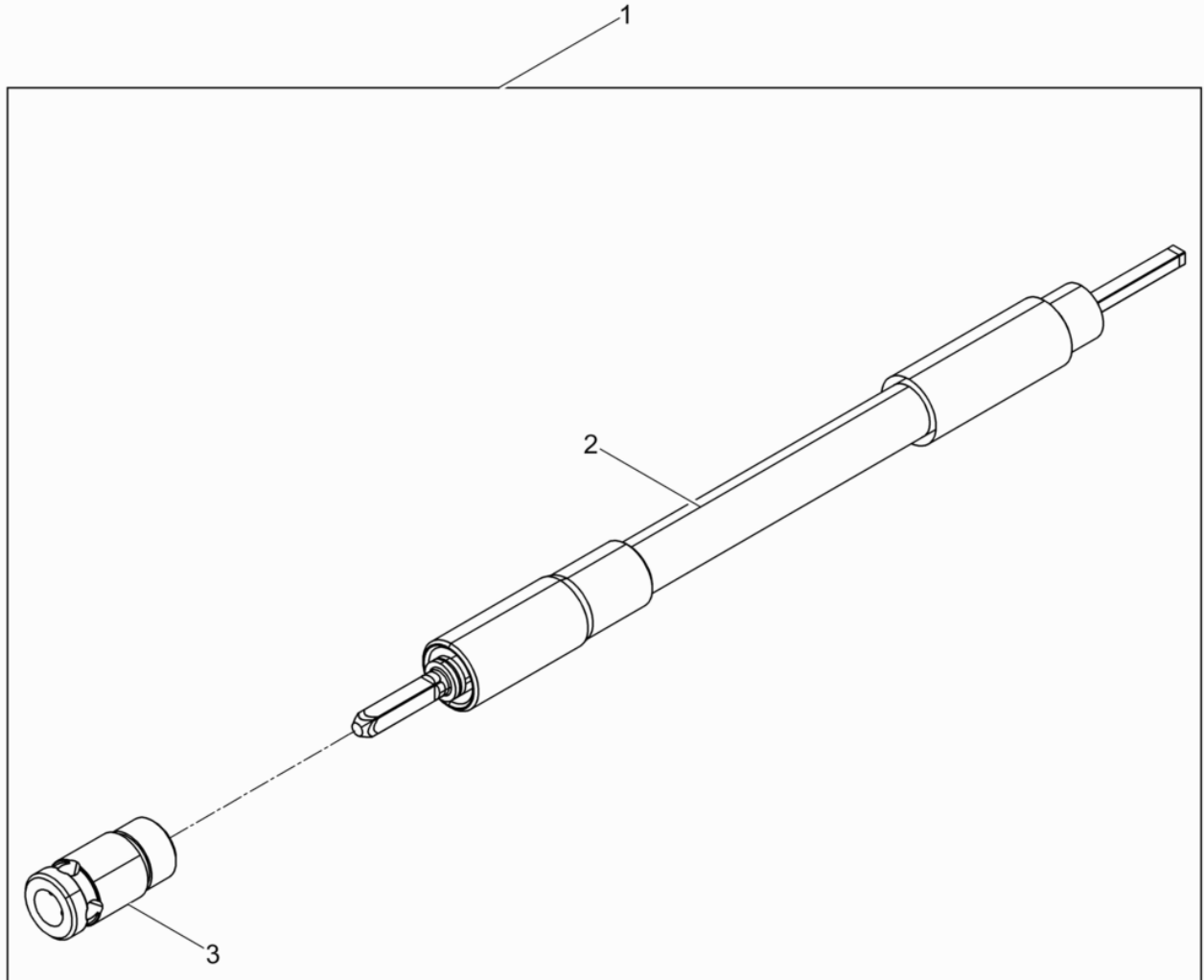

Ref. Pos.	Part No. Artikel Nr.	Qty. St.	Description Beschreibung	Descripción Description	Measurem./Abm.	Norm
					Torque/Drehm.	Sealant Schmierstoff
1	0086245	1	Flex Shafts SM 4E Biegewelle SM 4E	Ejes Flexibles SM 4E Transmission Flexible SM 4E		
2	0086248	1	Inner core Wellenseele	Alma Arbre à transmission flexible		
3	0071584	1	Coupling Kupplung	Acoplamiento Couplage		

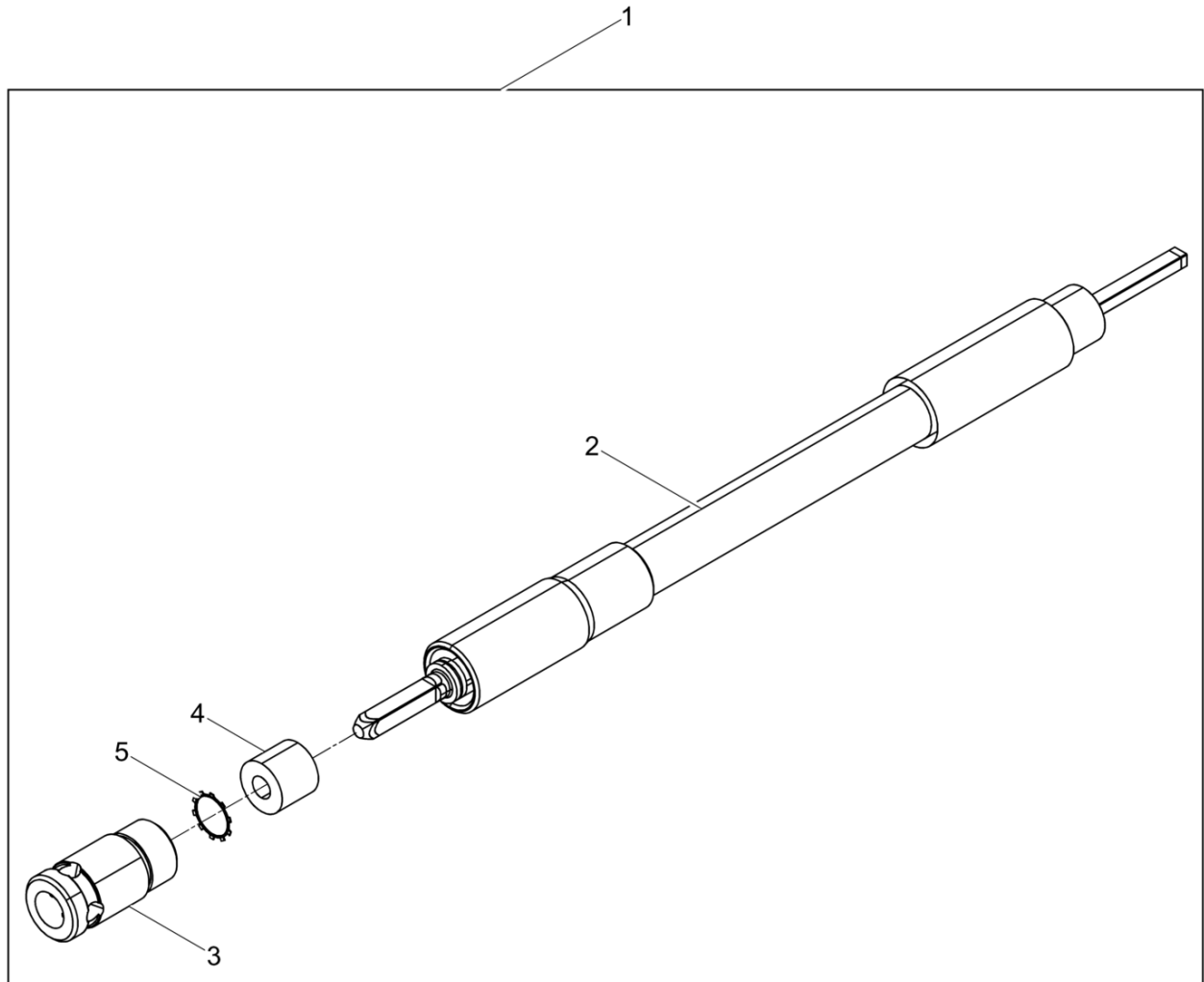

Ref. Pos.	Part No. Artikel Nr.	Qty. St.	Description Beschreibung	Descripción Description	Measurem./Abm.	Norm
					Torque/Drehm.	Sealant Schmierstoff
1	0080604	1	Flex Shafts SM 0S Biegewelle SM 0S	Ejes Flexibles SM 0S Transmission Flexible SM 0S		
2	0078330	1	Inner core Wellenseele	Alma Arbre à transmission flexible		
3	0071584	1	Coupling Kupplung	Acoplamiento Couplage		
4	0204866	1	Bush Kunststoffbuchse	Buje Boîte		
5	0204867	1	Retaining ring Sicherungsring	Anillo de retención Bague d'arrêt		

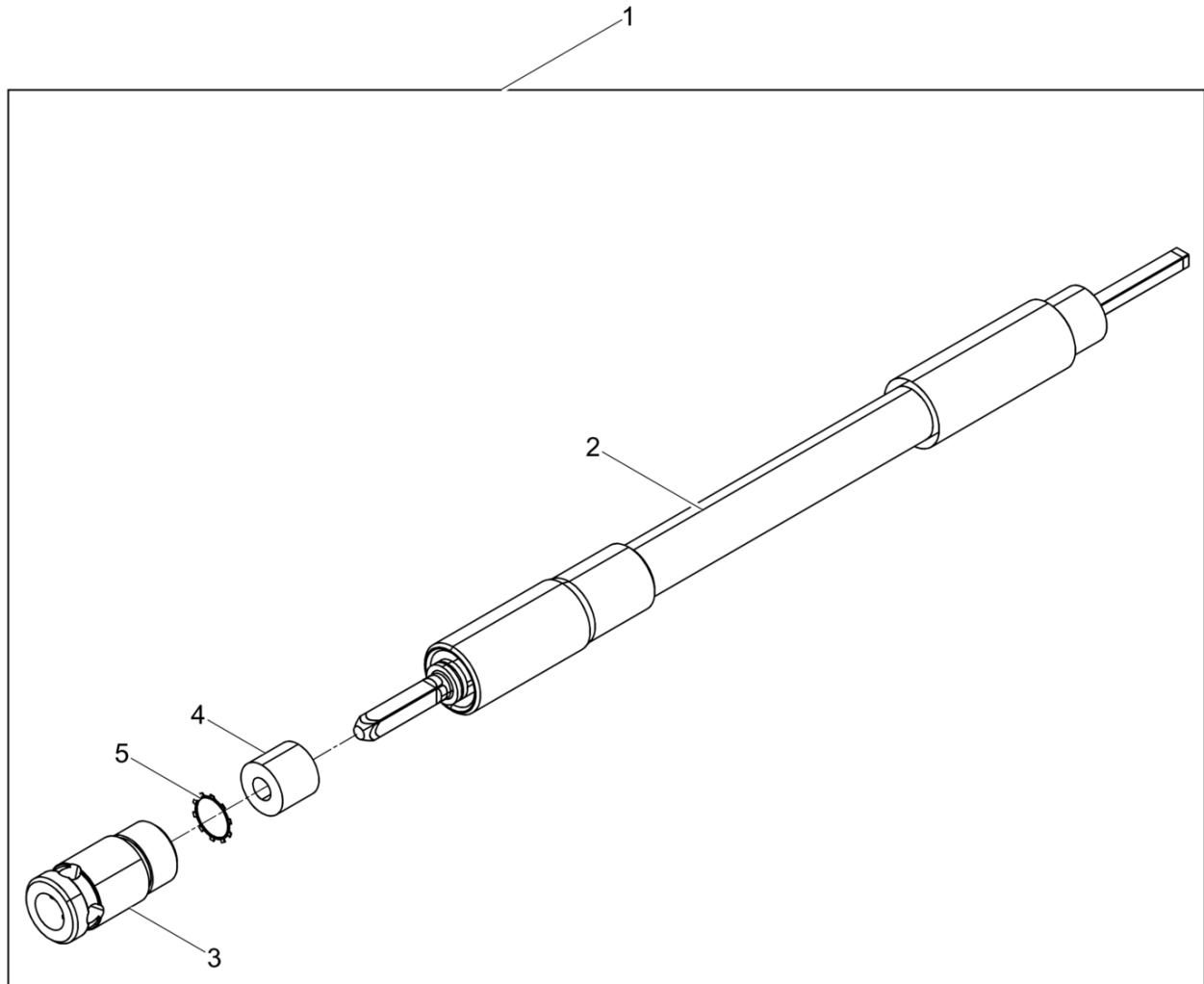

Ref. Pos.	Part No. Artikel Nr.	Qty. St.	Description Beschreibung	Descripción Description	Measurem./Abm.	Norm
					Torque/Drehm.	Sealant Schmierstoff
1	0080605	1	Flex Shafts SM 1S Biegewelle SM 1S	Ejes Flexibles SM 1S Transmission Flexible SM 1S		
2	0078331	1	Inner core Wellenseele	Alma Arbre à transmission flexible		
3	0071584	1	Coupling Kupplung	Acoplamiento Couplage		
4	0204866	1	Bush Kunststoffbuchse	Buje Boîte		
5	0204867	1	Retaining ring Sicherungsring	Anillo de retención Bague d'arrêt		

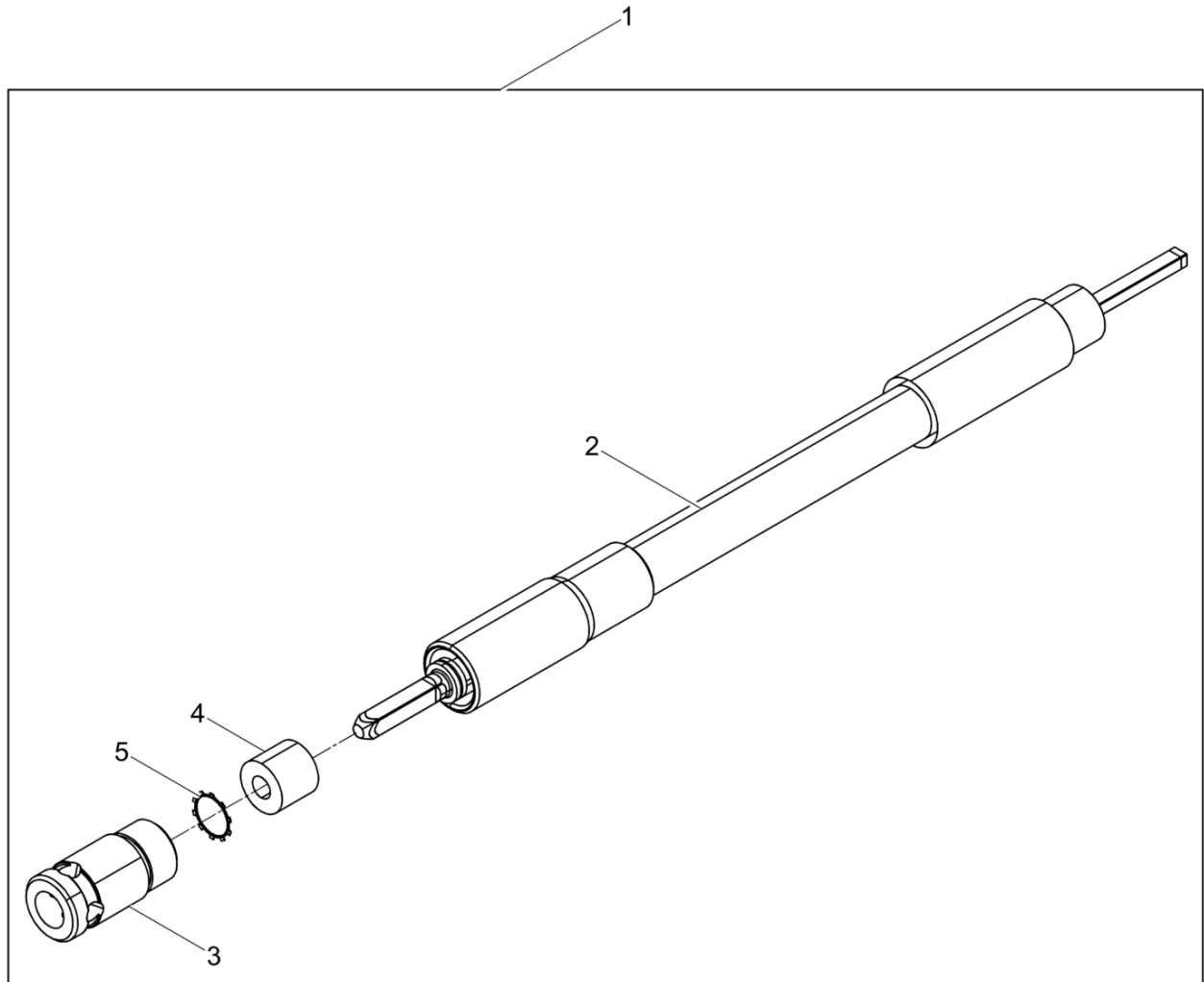

Ref. Pos.	Part No. Artikel Nr.	Qty. St.	Description Beschreibung	Descripción Description	Measurem./Abm.	Norm
					Torque/Drehm.	Sealant Schmierstoff
1	0080606	1	Flex Shafts SM 2S Biegewelle SM 2S	Ejes Flexibles SM 2S Transmission Flexible SM 2S		
2	0078332	1	Inner core Wellenseele	Alma Arbre à transmission flexible		
3	0071584	1	Coupling Kupplung	Acoplamiento Couplage		
4	0204866	1	Bush Kunststoffbuchse	Buje Boîte		
5	0204867	1	Retaining ring Sicherungsring	Anillo de retención Bague d'arrêt		

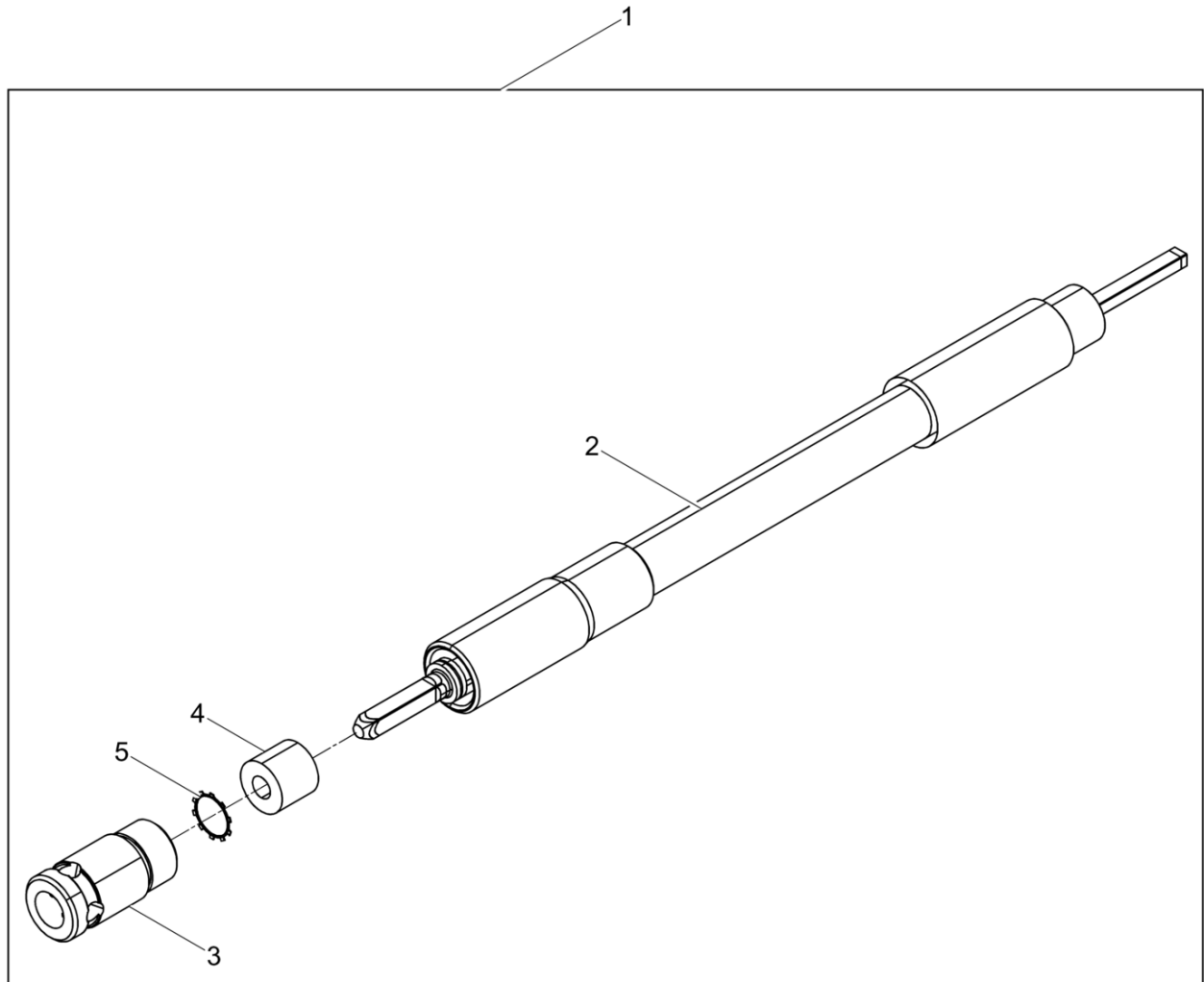

Ref. Pos.	Part No. Artikel Nr.	Qty. St.	Description Beschreibung	Descripción Description	Measur./Abm.	Norm
					Torque/Drehm.	Sealant Schmierstoff
1	0080607	1	Flex Shafts SM 3S Biegewelle SM 3S	Ejes Flexibles SM 3S Transmission Flexible SM 3S		
2	0078333	1	Inner core Wellenseele	Alma Arbre à transmission flexible		
3	0071584	1	Coupling Kupplung	Acoplamiento Couplage		
4	0204866	1	Bush Kunststoffbuchse	Buje Boîte		
5	0204867	1	Retaining ring Sicherungsring	Anillo de retención Bague d'arrêt		

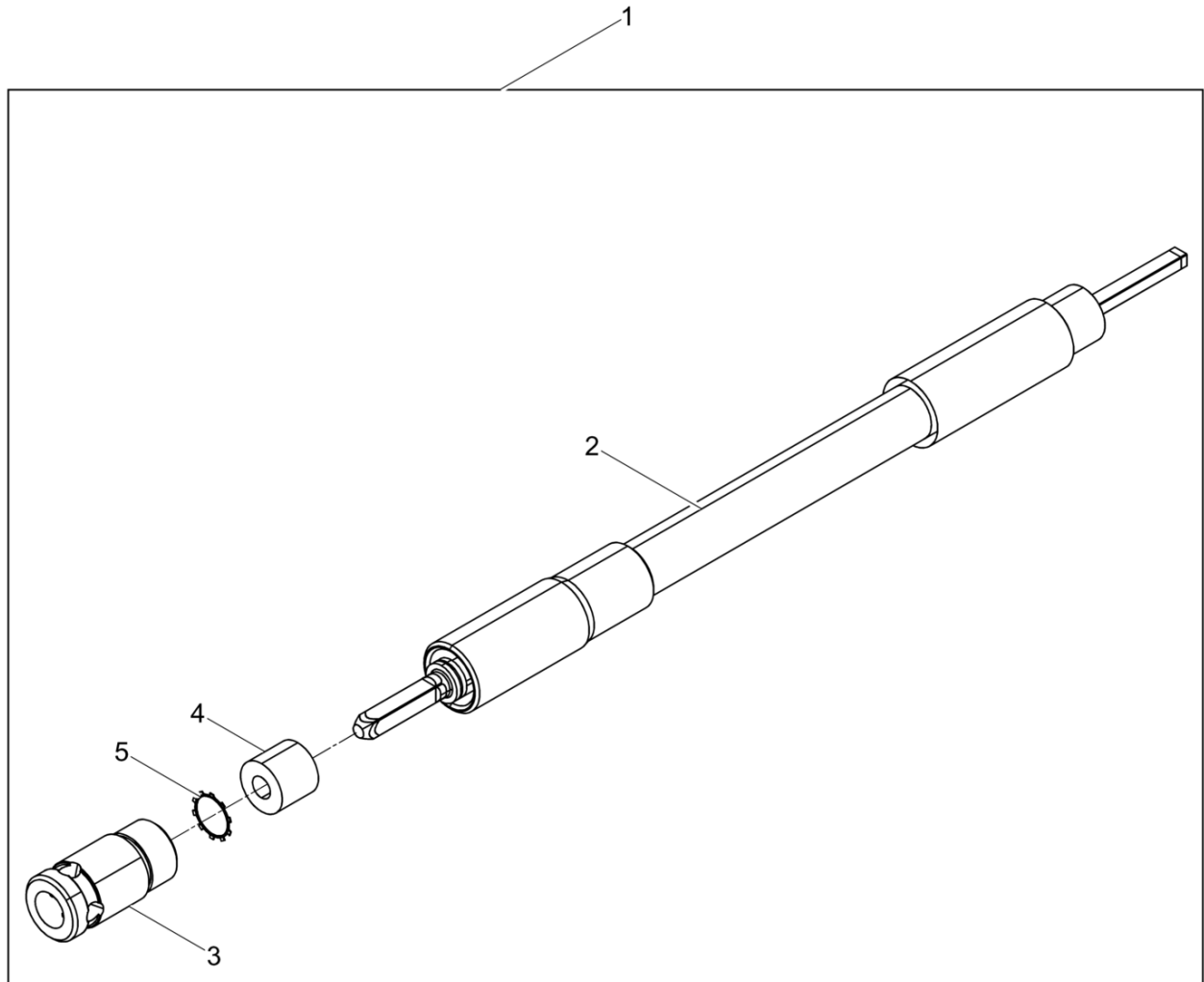

Ref. Pos.	Part No. Artikel Nr.	Qty. St.	Description Beschreibung	Descripción Description	Measurem./Abm.	Norm
					Torque/Drehm.	Sealant Schmierstoff
1	0080608	1	Flex Shafts SM 4S Biegewelle SM 4S	Ejes Flexibles SM 4S Transmission Flexible SM 4S		
2	0078334	1	Inner core Wellenseele	Alma Arbre à transmission flexible		
3	0071584	1	Coupling Kupplung	Acoplamiento Couplage		
4	0204866	1	Bush Kunststoffbuchse	Buje Boîte		
5	0204867	1	Retaining ring Sicherungsring	Anillo de retención Bague d'arrêt		

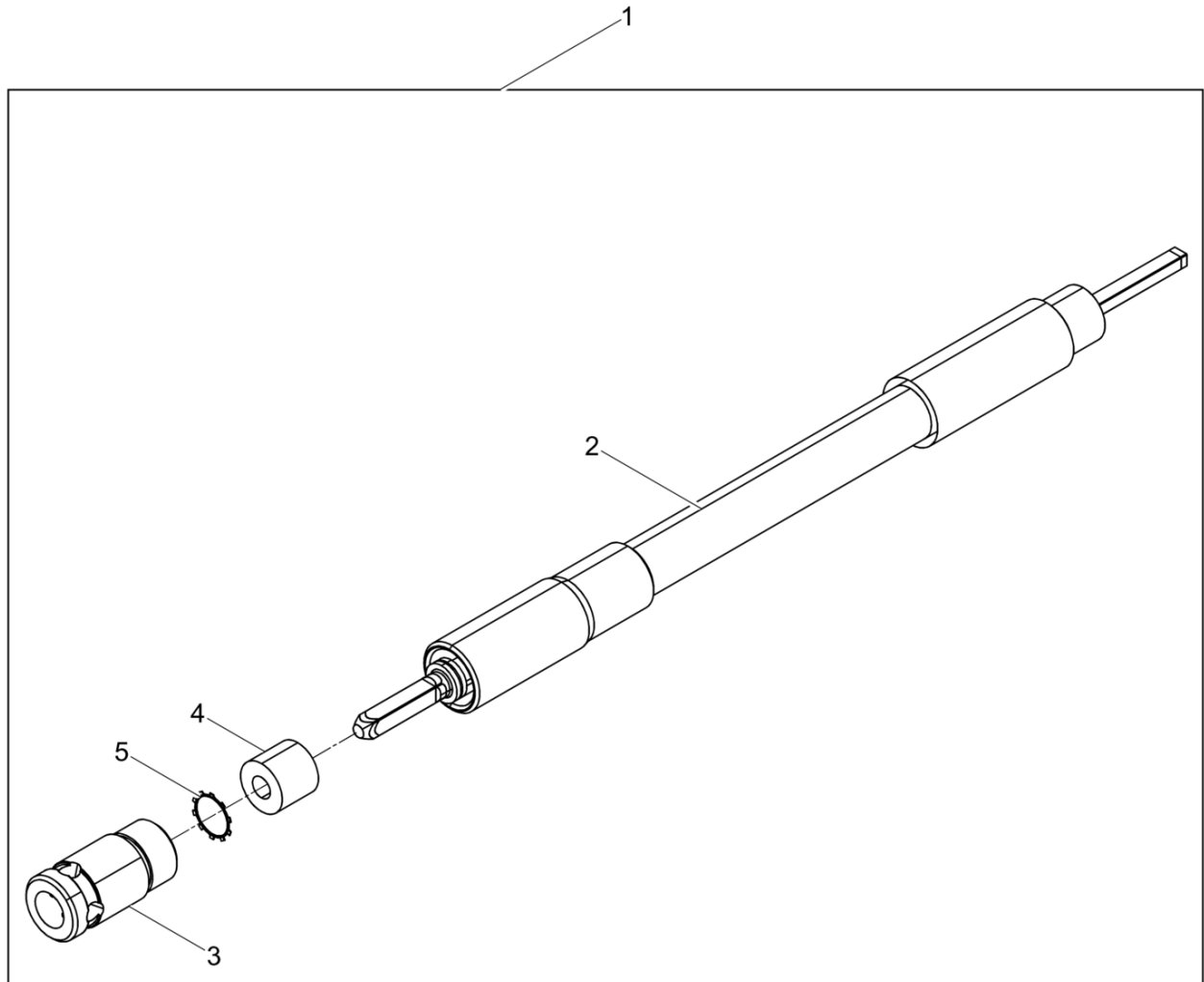

Ref. Pos.	Part No. Artikel Nr.	Qty. St.	Description Beschreibung	Descripción Description	Measurem./Abm.	Norm
					Torque/Drehm.	Sealant Schmierstoff
1	0080609	1	Flex Shafts SM 5S Biegewelle SM 5S	Ejes Flexibles SM 5S Transmission Flexible SM 5S		
2	0078335	1	Inner core Wellenseele	Alma Arbre à transmission flexible		
3	0071584	1	Coupling Kupplung	Acoplamiento Couplage		
4	0204866	1	Bush Kunststoffbuchse	Buje Boîte		
5	0204867	1	Retaining ring Sicherungsring	Anillo de retención Bague d'arrêt		

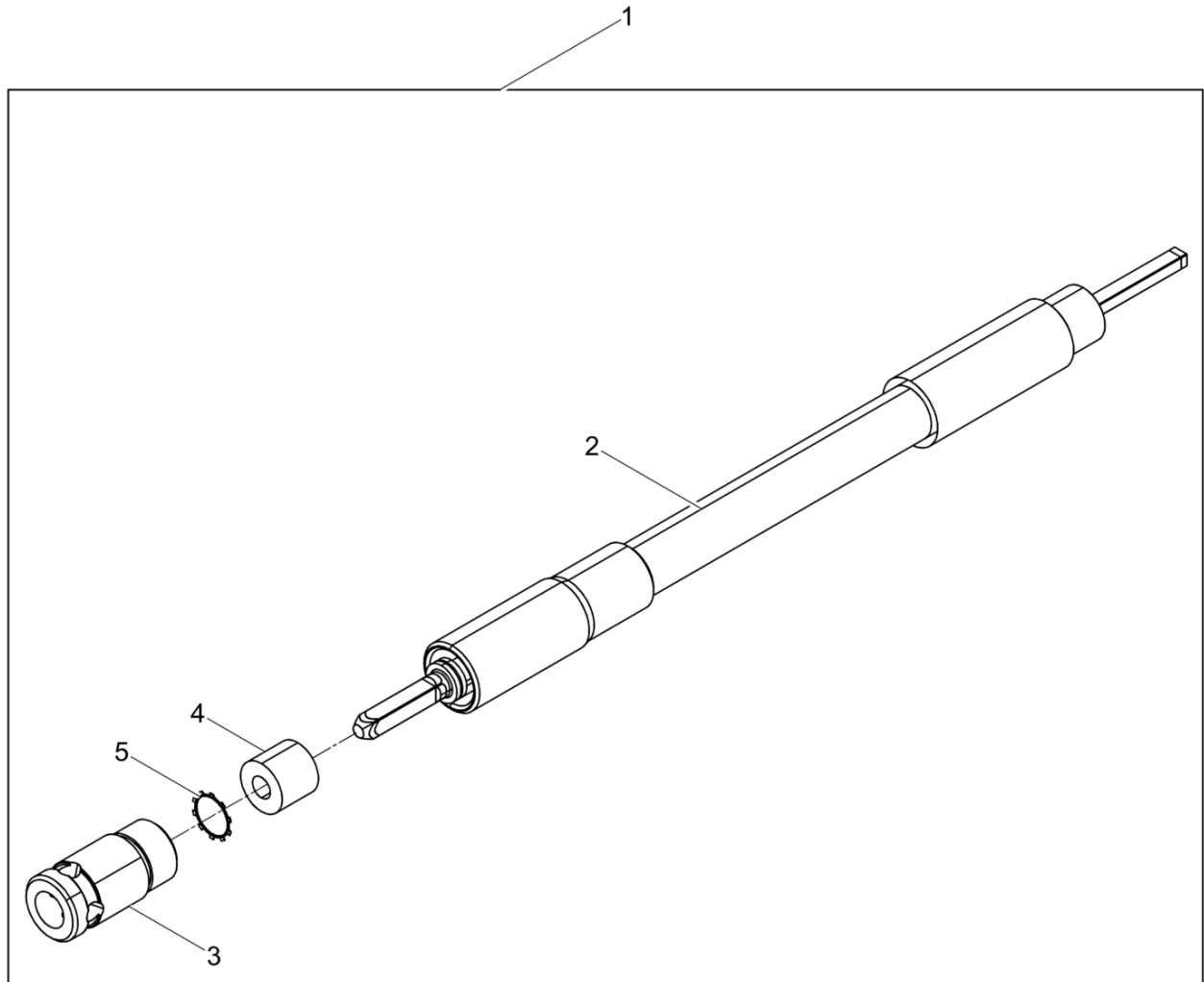

Ref. Pos.	Part No. Artikel Nr.	Qty. St.	Description Beschreibung	Descripción Description	Measurem./Abm.	Norm
					Torque/Drehm.	Sealant Schmierstoff
1	0080610	1	Flex Shafts SM 7S Biegewelle SM 7S	Ejes Flexibles SM 7S Transmission Flexible SM 7S		
2	0078336	1	Inner core Wellenseele	Alma Arbre à transmission flexible		
3	0071584	1	Coupling Kupplung	Acoplamiento Couplage		
4	0204866	1	Bush Kunststoffbuchse	Buje Boîte		
5	0204867	1	Retaining ring Sicherungsring	Anillo de retención Bague d'arrêt		

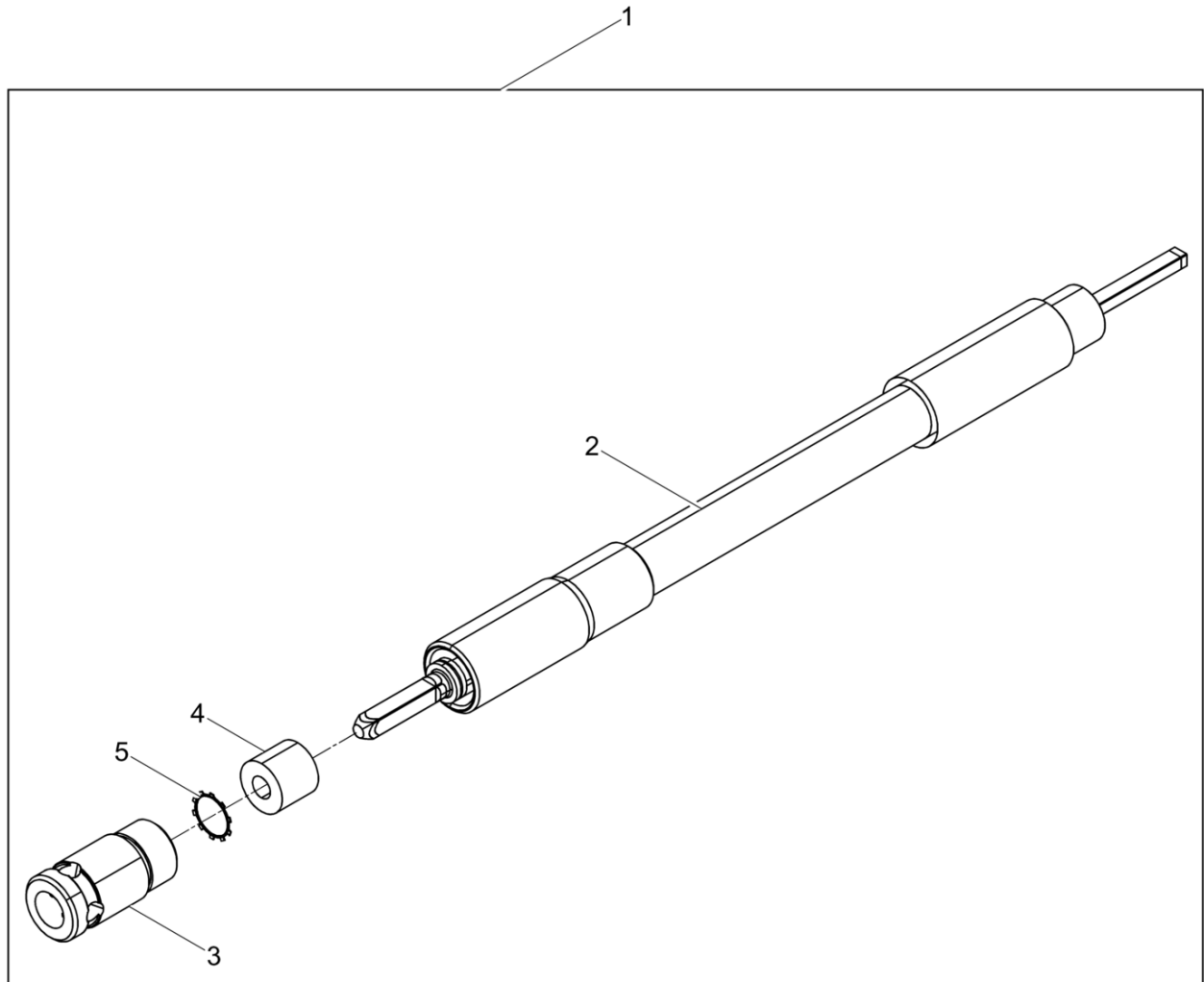

Ref. Pos.	Part No. Artikel Nr.	Qty. St.	Description Beschreibung	Descripción Description	Measurement./Abm.	Norm
					Torque/Drehm.	Sealant Schmierstoff
1	0085860	1	Flex Shafts SM 9S Biegewelle SM 9S	Ejes Flexibles SM 9S Transmission Flexible SM 9S		
2	0085861	1	Inner core Wellenseele	Alma Arbre à transmission flexible		
3	0071584	1	Coupling Kupplung	Acoplamiento Couplage		
4	0204866	1	Bush Kunststoffbuchse	Buje Boîte		
5	0204867	1	Retaining ring Sicherungsring	Anillo de retención Bague d'arrêt		

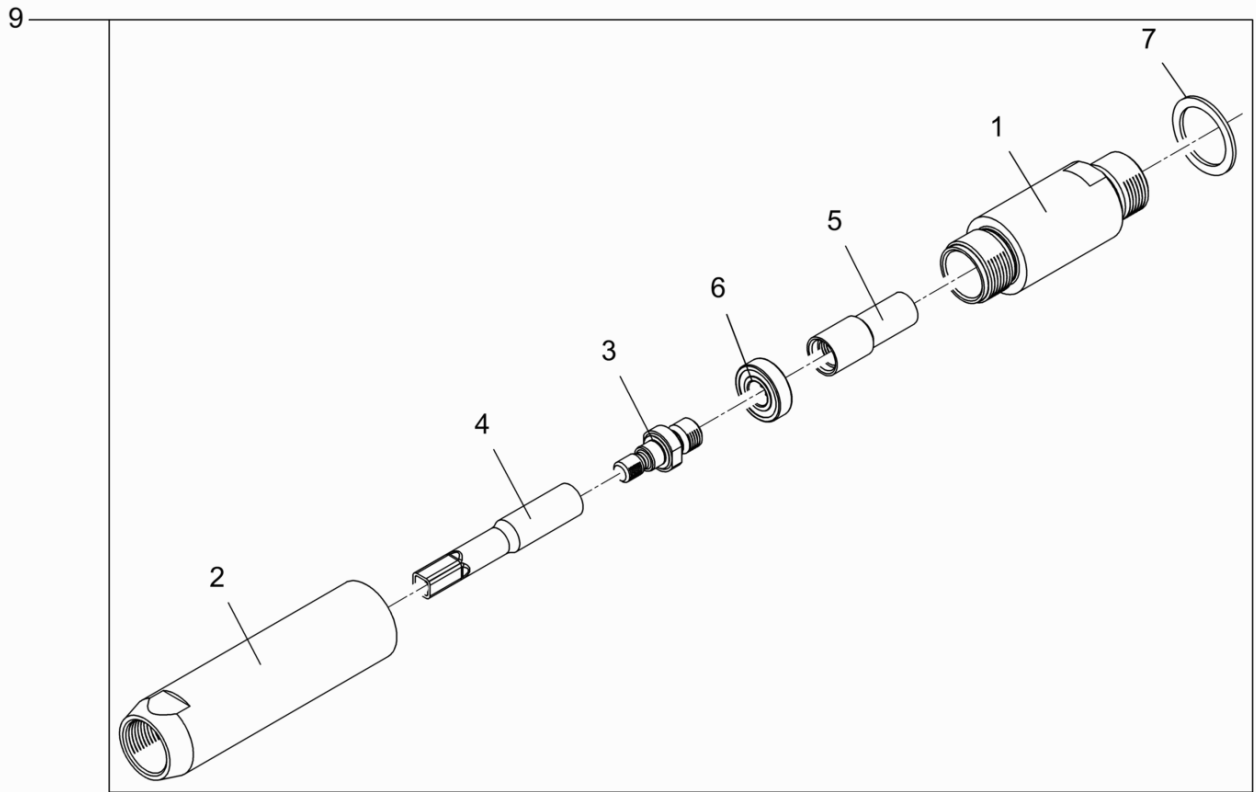

Ref. Pos.	Part No. Artikel Nr.	Qty. St.	Description Beschreibung	Descripción Description	Measurement/Abm.	Norm
					Torque/Drehm.	Sealant Schmierstoff
1	0203315	1	Housing Gehäuse	Carcasa Carter		
2	0203314	1	Housing Gehäuse	Carcasa Carter		
3	0203313	1	Shaft Welle	Eje Arbre		
4	0029755	1	Inner core adaptor Wellenseelenadapter	Adaptador alma Adaptateur arbre à transmission flexible		
5	0053934	1	Adaptor Adapter	Adaptador Adaptateur		
6	0054358	1	Grooved ball bearing Rillenkugellager	Rodamiento de bolas Roulement à billes		
7	0026872	1	Washer Scheibe	Arandela Rondelle		
9	0203316	1	SS Adaptor SS-Adapter	Adaptador SS Adaptateur SS		

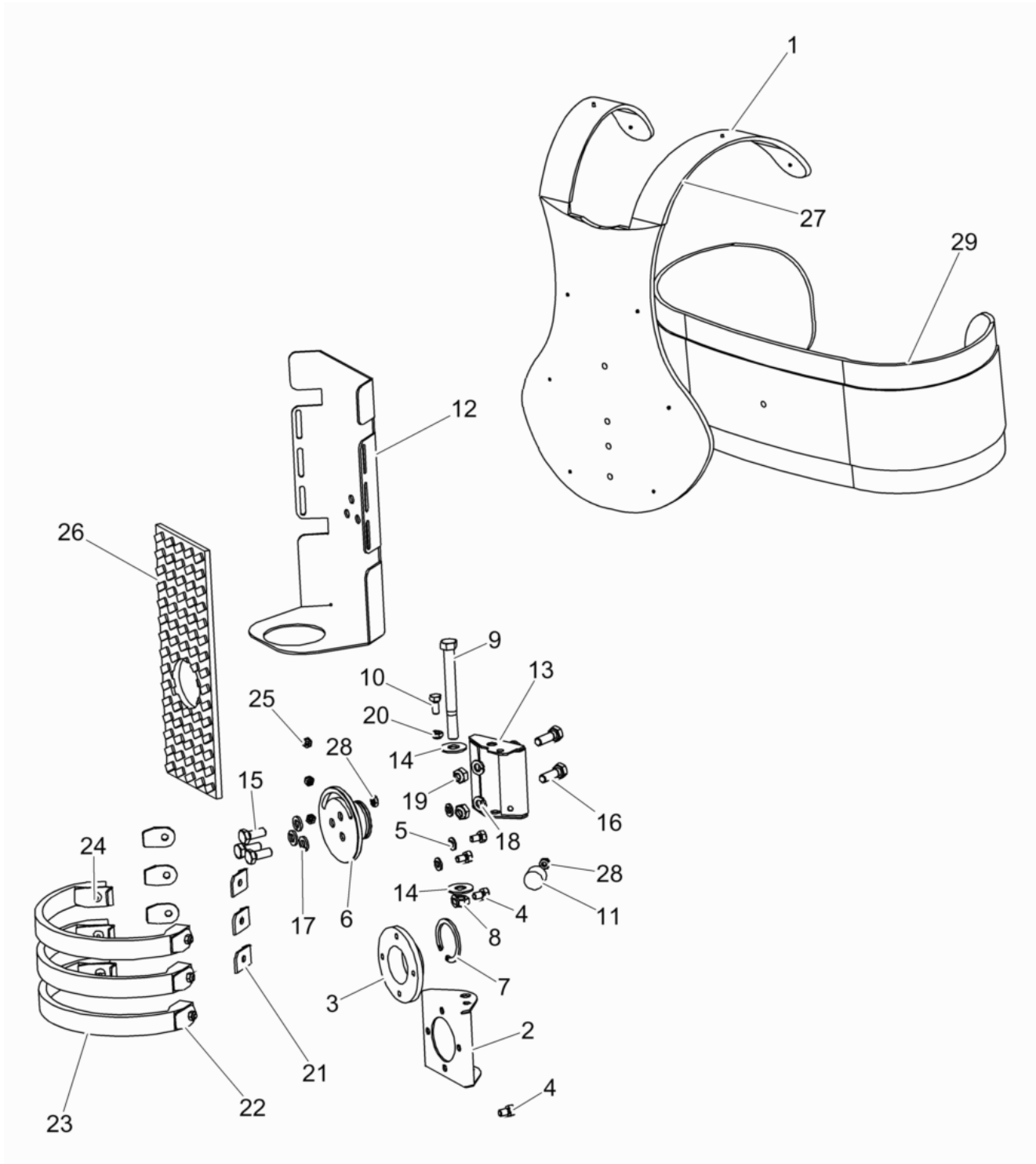

Ref. Pos.	Part No. Artikel Nr.	Qty. St.	Description Beschreibung	Descripción Description	Measurement/Abm.	Norm
					Torque/Drehm.	Sealant Schmierstoff
1	0174765	1	Strap Tragegurt	Correa Ruban		
2	0174482	1	Engine Mount Assembly Motorkonsole	Conjunto Soporte de Motor Montage du Moteur		
3	0174766	1	Bushing Buchse	Buje Douille		
4	0174806	4	Screw Schraube	Tornillo Vis	M6 x 10	
5	0174804	4	Spring washer Federring	Arandela de resorte Rondelle de ressort	M6	
6	0174767	1	Flange Flansch	Brida Bride		
7	0174768	1	Retaining ring Sicherungsring	Anillo de retención Bague d'arrêt		
8	0174831	1	Locknut Sicherungsmutter	Contratuerca Contre-écrou	3,8-16	
9	0174822	1	Hexagonal head cap screw Sechskantschraube	Tornillo hexagonal Vis à tête hexagonale	3/8-16x3-3/4	
10	0157752	1	Screw Schraube	Tornillo Vis		
11	0174761	2	Silent block Gummipuffer	Bloque silente Silentbloc		
12	0174757	1	Bracket Halterung	Soporte Équerre		
13	0174758	1	Console Konsole	Consola Console		
14	0174764	2	Washer Scheibe	Disco Rondelle		
15	0157753	3	Screw Schraube	Tornillo Vis		
16	0157768	2	Screw Schraube	Tornillo Vis		
17	0174805	5	Spring washer Federring	Arandela de resorte Rondelle de ressort	M8	
18	0174834	2	Washer Scheibe	Disco Rondelle	M8	
19	0174803	2	Locknut Sicherungsmutter	Contratuerca Contre-écrou	M8	
20	0174808	1	Locknut Sicherungsmutter	Contratuerca Contre-écrou	M6	
21	0174759	6	square washer Vierkantscheibe	plaquette carrée cale de serrage		
22	0174760	6	square washer Vierkantscheibe	plaquette carrée cale de serrage		
23	0174762	3	Belt Gurt	Cinturón ceinture		
24	0174838	6	Bolt Bolzen	Perno Boulon	M 5x25	
25	0174819	6	Hexagon nut Sechskantmutter	Tuerca hexagonal Écrou hexagonal	M 5	

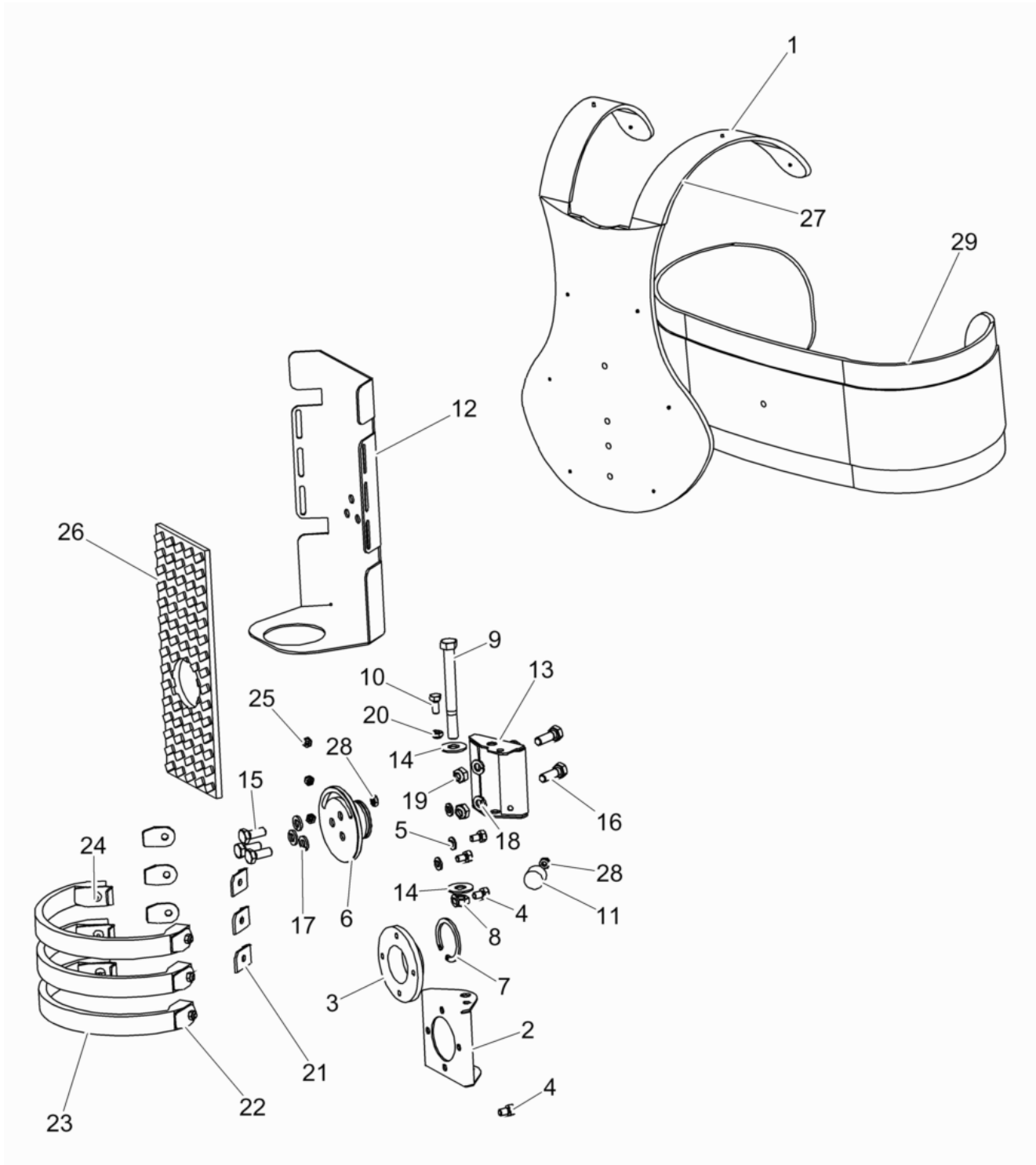

Ref. Pos.	Part No. Artikel Nr.	Qty. St.	Description Beschreibung	Descripción Description	Measurem./Abm.	Norm
					Torque/Drehm.	Sealant Schmierstoff
26	0174763	1	Rubber plate Gummiplatte	Placa de goma Plaque		
27	0174782	1	Base Unterlage	Base Base		
28	0174769	2	Hexagon nut Sechskantmutter	Tuerca hexagonal Écrou hexagonal	10-32	
29	0174783	1	Belt Gurt	Cinturón ceinture		



**WACKER
NEUSON**

**Service
Service
Servicio
Service**

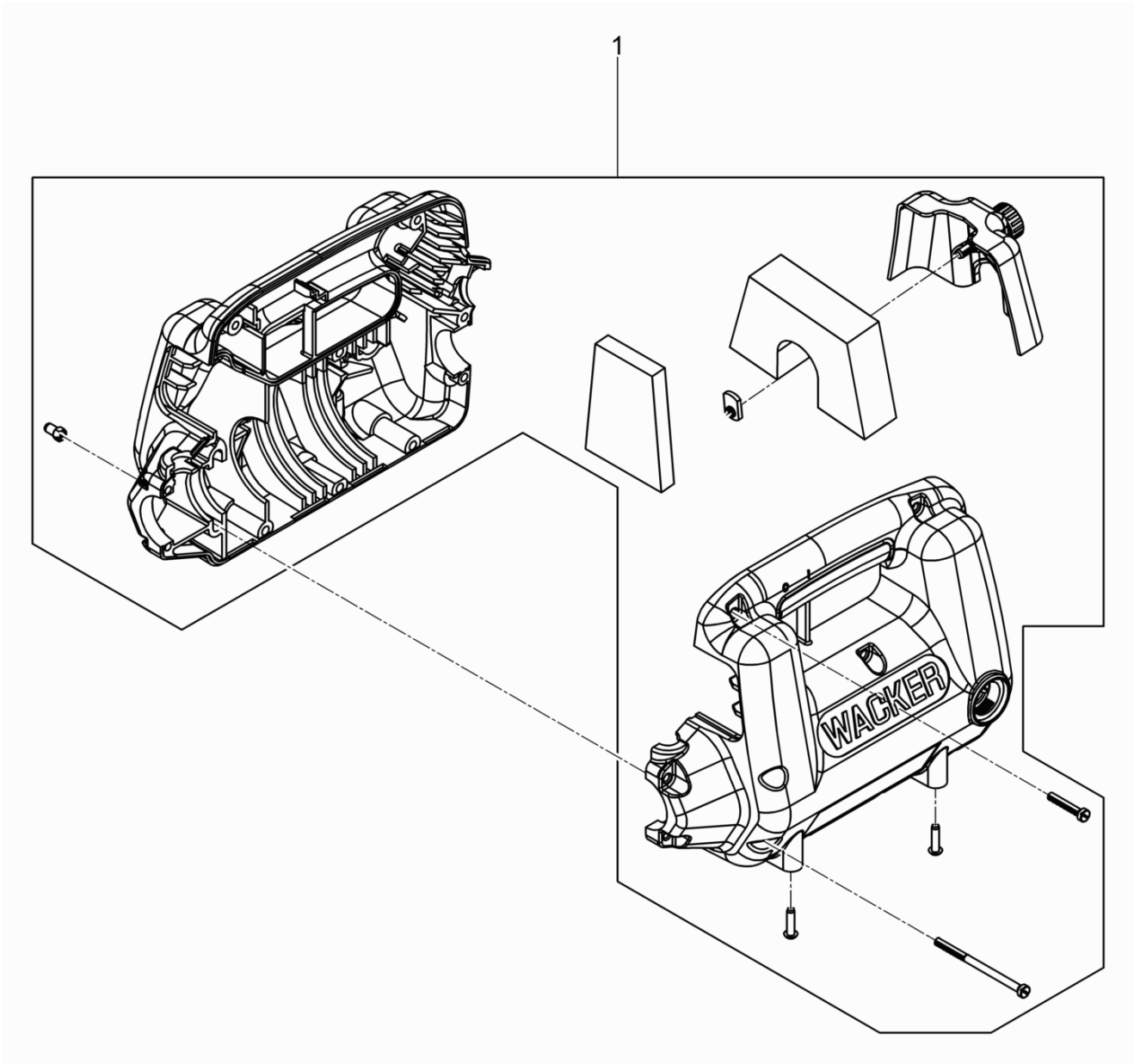

M3000/230/RFI

**Motor Housing assemebly
Motorgehäusesatz
Conjunto Carcasa de Motor
Jeu-Carter de Moteur**

Ref. Pos.	Part No. Artikel Nr.	Qty. St.	Description Beschreibung	Descripción Description	Measurement./Abm.	Norm
					Torque/Drehm.	Sealant Schmierstoff
1	0083090	1	Motor Housing assemebly M3000 Motorgehäusesatz M3000	Conjunto Carcasa de Motor M3000 Jeu-Carter de Moteur M3000		



**WACKER
NEUSON**