



**WACKER
NEUSON**

5200019285	107
12.2017	

**Light Towers
Beleuchtungsanlagen
Torres de Iluminación
Tours d'eclairage**

LTN6LE-V

**Parts Book
Ersatzteile
Lista de Repuestos
Liste de Pièces de Rechange**

www.wackerneuson.com

A nameplate listing the Model Number, Item Number, Revision, and Serial Number is attached to each unit. Please record the information found on this plate so it will be available should the nameplate become lost or damaged. When ordering parts or requesting service information, you will always be asked to specify the model, item number, revision number, and serial number of the unit.

Ein Typenschild mit Typ, Artikelnummer, Version und Maschinen-Nummer ist an jedem Gerät angebracht. Die Daten von diesem Schild bitte notieren, damit sie auch bei Verlust oder Beschädigung des Schildes noch vorhanden sind. Der Typ, die Artikel-Nummer, die Versions- Nummer und die Maschinen-Nummer sind bei der Ersatzteilbestellung oder Nachfragen bezüglich Service-Informationen stets erforderlich.

Una placa de identificación con el modelo, número de referencia, nivel de revisión y número de serie ha sido añadida en cada máquina. Favor de anotar los datos en la placa en caso de que la placa de identificación sea destruida o perdida. En todos los pedidos para repuestos necesita siempre el modelo, el número de referencia, el nivel de revisión y el número de serie de la máquina en cuestión.

Une plaque signalétique mentionnant le modèle, le numéro de référence, le niveau de révision et le numéro de série est fixée sur chaque machine. Veuillez noter les informations relevées sur cette plaque de façon à ce qu'elles soient toujours disponibles si la plaque signalétique venait à être perdue ou endommagée. Lorsque vous commandez des pièces détachées ou vous sollicitez des informations après-vente, on vous demandera toujours de préciser le modèle, le numéro de référence, le niveau de révision et le numéro de série de la machine.

***My machine's numbers are / Die Nummern meines Gerätes sind /
Los números de mi máquina son / Les numéros de ma machine son :***



Part Numbers appearing in boldface type are recommended spare parts. This means that these parts are subject to wear under normal operating conditions and may require periodic service or replacement. It is recommended that these items be stocked to meet the expected service requirements of this model. Actual stocking quantities of these and other parts used in more extensive repairs will depend on the service practices of each customer.

Bei den in den Ersatzteillisten fettgedruckten Nummern handelt es sich um empfohlene Ersatzteile. Dies bedeutet, daß diese Teile bei normalen Anwendungsbedingungen natürlicher Abnutzung ausgesetzt sind und gelegentlich ersetzt oder überarbeitet werden müssen. Es wird geraten, diese Teile auf Lager bereit zu haben, um für Service-Arbeiten an diesem Gerät vorbereitet zu sein. Lagerbestände für diese und andere Teile, welche für ausgiebigere Reparaturarbeiten benötigt werden, können je nach Service-Gewohnheiten der einzelnen Kunden variieren.

Los números de partes en negritas en las Listas Ilustradas de Partes son los repuestos recomendados, ésto quiere decir que estas partes se desgastarán bajo circunstancias de funcionamiento normales y pueden requerir servicio periódico o su reemplazo. Se recomienda que el cliente mantenga un abastecimiento adecuado de estas partes para poder satisfacer la demanda requerida por el servicio a la máquina. La cantidad de repuestos que el cliente necesitará para reparaciones dependerá de la póliza de servicio de cada cliente.

Les numéros de pièces imprimés en caractères gras dans les Listes des Pièces Détachées de ce manuel sont les pièces détachées recommandées par la Wacker. Cela veut dire que ces pièces sont sujettes à usure dans des conditions de travail normales et peuvent nécessiter de l'entretien ou leur remplacement. Nous recommandons que vous disposez d'un stock de ces pièces pour pouvoir satisfaire la demande d'entretien de cette machine. Le client doit décider lui-même de la quantité exacte de pièces de rechange qu'il disposera dans ses stocks.

Tower cpl. Turm kpl. Torre compl. Tour compl.	8
Light fixture Licht Artefacto Projecteur	10
Option-Power Rotator Sonderzubehör-Drehvorrichtung Opción-Dispositivo giratorio Option-Appareil rotatif	12
LED Light cpl. Beleuchtungseinrichtung - LED Artefactos compl. - LED Projecteurs compl. - DEL	16
Tower section 0 Turm, Teil 0 Sección de la torre - 0 Section de la tour - 0	18
Tower section 1 Turm, Teil 1 Sección de la torre - 1 Section de la tour - 1	20
Tower section 2 Turm, Teil 2 Sección de la torre - 2 Section de la tour - 2	22
Tower section 3 Turm, Teil 3 Sección de la torre - 3 Section de la tour - 3	24
Tower section 4 Turm, Teil 4 Sección de la torre - 4 Section de la tour - 4	26
Tower section 5 Turm, Teil 5 Sección de la torre - 5 Section de la tour - 5	28
Tower section 6 Turm, Teil 6 Sección de la torre - 6 Section de la tour - 6	30
Tower section 7 Turm, Teil 7 Sección de la torre - 7 Section de la tour - 7	32
Tower section 8 Turm, Teil 8 Sección de la torre - 8 Section de la tour - 8	34
Driver cpl. Ballast kpl. Balastro compl. Matériau de ballast compl.	36

Indice**Table des matières**

Control Box/Battery LTNV CE Kontrollkasten/Batterie Caja de control/Batería Boîtier de commande/Batterie	38
Control Panel - AUS. RCBO Schalttafel - AUS. RCBO Tablero de Mando - AUS. RCBO Tableau de Commande - AUS.RCBO	40
Fuel Tank/Lifteye Kraftstofftank/Hebeöse Tanque de Combustible/Punto deizaje Réservoir de Carburant/Anneau	42
Switch/Hydraulic pump Schalter/Hydraulikpumpe Interruptor/Bomba hidráulica Interrupteur/Pompe hydraulique	44
Generator cpl. Generator kpl. Conjunto generador Générateur compl.	46
Generator/Engine Support Generator/Motorbefestigung Generador/Montaje del Motor Générateur/Montage du Moteur	48
Skid Palette Paleta Palette	50
Enclosure Panels Gehäuseblechtafeln Paneles de la cubierta Tableaux de l'enceinte	52
Option-Containment skid Sonderzubehör-Sammelbecken Opción-Recipiente colector Option-Réservoir à liquides	54
Labels Aufkleber Calcomanias Autocollants	56
Labels Aufkleber Calcomanias Autocollants	58
Engine-Kohler Kohler-Motor Motor Kohler Moteur Kohler	61
Engine-Lombardini Lombardini-Motor Motor Lombardini Moteur Lombardini	62
Intake/Exhaust Einlass/Auspuff Admisión/Escape Admission/Échappement	64

Piston/Connecting Rod Kolben/Pleuel Pistón/Biela Piston/Bielle	66
Crankshaft/Flywheel Kurbelwelle/Schwungrad Cigueñal/Volante Vilebrequin/Volant	68
Timing/Speed Governor Regler Regulación del Encendido/Velocidad Régulateur	70
Crankcase cpl. Kurbelgehäuse kpl. Cárter compl. Carter compl.	74
Fuel System Kraftstoffsystem Sistema de Combustible Système d'Essence	78
Radiator cpl. Kühler kpl. Radiador compl. Radiateur compl.	84
Lubrication System Schmierung Lubricación Lubrification	90
Controls Steuerungen Mandos Commandes	94
Cylinder Head Zylinderkopf Culata Culasse	96
Electrical Components Elektrische Bestandteile Piezas Eléctricas Parties Constituanates Électri	100
Maintenance Kit Wartungssatz Juego de reparación Jeu d'entretien	104

Tower cpl.
Turm kpl.
Torre compl.
Tour compl.

LTN6LE-V

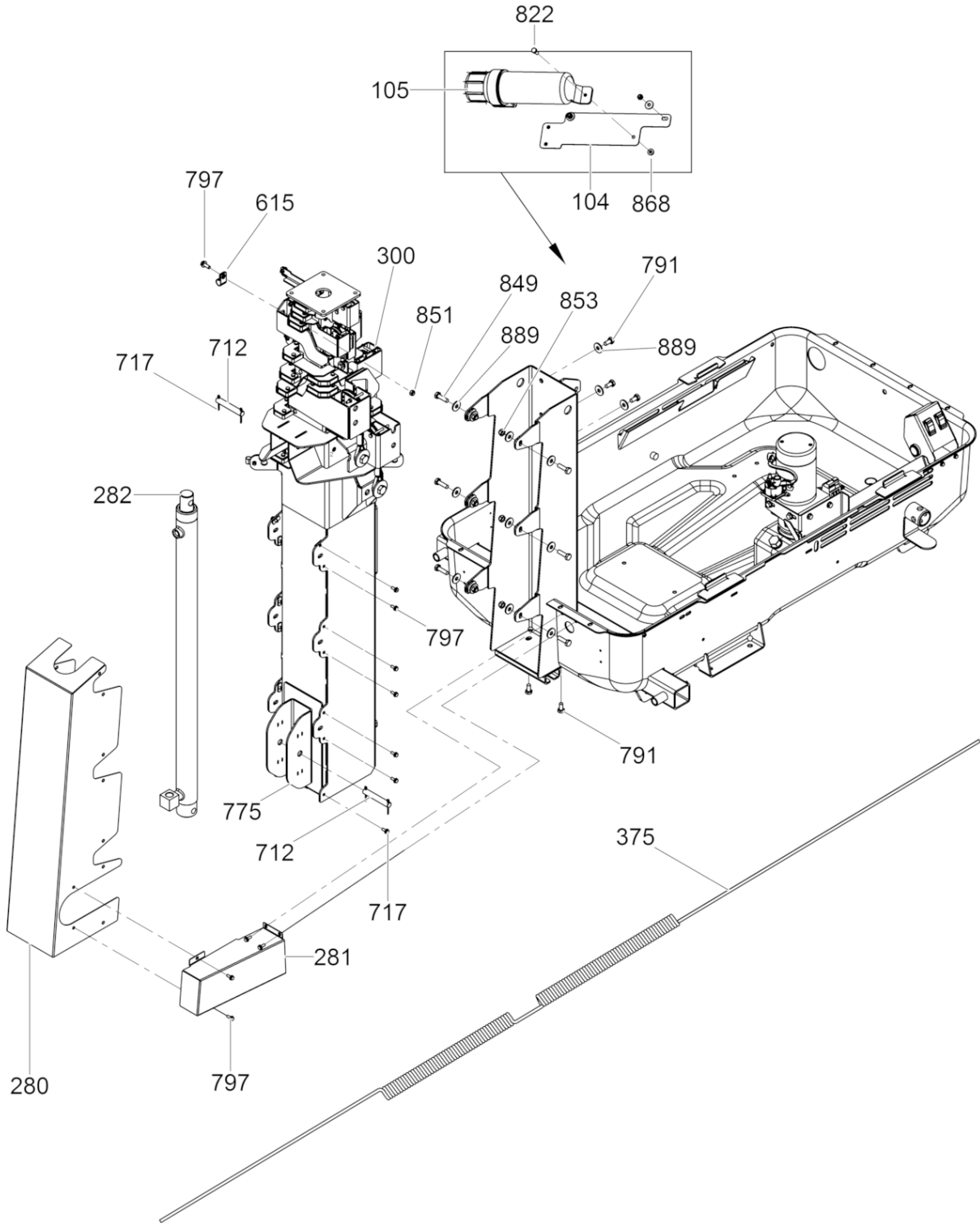

200_5200002720109001

Ref. Pos.	Part No. Artikel Nr.	Qty. St.	Description Beschreibung	Descripción Description	Measurem./Abm.	Norm
					Torque/Drehm.	Sealant Schmierstoff
104	5100020716	1	Bracket Konsole	Soporte Support		
105	5200008089	1	Manual holder Handbuchhalter	Soporte manual Support de manuel		
280	5200001988	1	Cover Deckel	Tapa Couvercle		
281	5200002267	1	Cover Deckel	Tapa Couvercle		
282	5200002263	1	Hydraulic cylinder Hydrozylinder	Cilindro hidráulico Cylindre hydraulique		
300	5200009285	1	Tower Tubes Turmröhre	Tubos de la torre Tubes de la tour		
375	5200001980	1	Cord Kabel	Cable Cordon		
615	5000163956	3	Clamp Schelle	Abrazadera Agrafe		
712	5200002266	2	Pin Stift	Pasador Goupille		
717	5000116751	4	Cotter pin Sicherungssplint	Clavija hendida Goupille fendue	1/8 x 1-1/2in	
775	5000111458	1	Cable tie Kabelbinder	Atadura de cable Serre-câble	3,6 x 203	
791	5000012364	5	Hexagonal head cap screw Sechskantschraube	Tornillo hexagonal Vis à tête hexagonale	M10 x 20 49Nm/36ft.lbs	DIN933
797	5000028949	21	Screw Schraube	Tornillo Vis	M6 x 16 10Nm/7ft.lbs	
822	5000012362	3	Hexagonal head cap screw Sechskantschraube	Tornillo hexagonal Vis à tête hexagonale	25Nm/18ft.lbs	
849	5000011438	6	Hexagonal head cap screw Sechskantschraube	Tornillo hexagonal Vis à tête hexagonale	M10 x 35 49Nm/36ft.lbs	DIN933
851	5000010368	3	Hexagon nut Sechskantmutter	Tuerca hexagonal Écrou hexagonal	M6	DIN985
853	5000010365	6	Lock nut Sicherungsmutter	Contratuerca Contre-écrou	M10	DIN980
868	5000030066	5	Locknut Sechskantmutter	Contratuerca Contre-écrou	M8	
889	5000010375	15	Flat washer Scheibe	Arandela Rondelle	B10,5	DIN9021

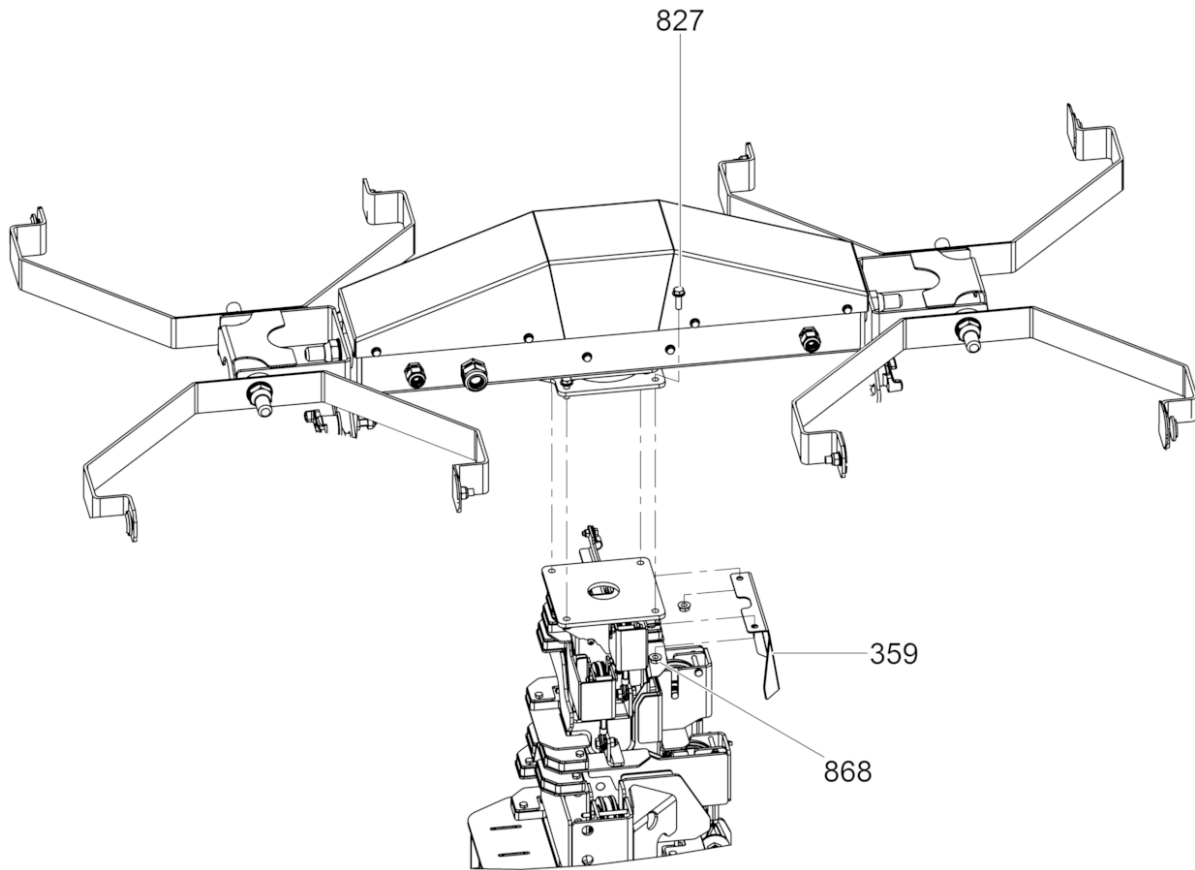

200_5200002720100002

Ref. Pos.	Part No. Artikel Nr.	Qty. St.	Description Beschreibung	Descripción Description	Measurement/Abm.	Norm
					Torque/Drehm.	Sealant Schmierstoff
359	5100021193	1	Bracket Konsole	Soporte Support		
827	5000180119	4	Hexagonal flange head screw Sechskantflanschschaube	Tornillo hexagonal de brida Vis hexagonale de bride	M8 x 25	
868	5000030066	4	Locknut Sechskantmutter	Contratuerca Contre-écrou	M8	

Option-Power Rotator
 Sonderzubehör-Drehvorrichtung
 Opción-Dispositivo giratorio
 Option-Appareil rotatif

LTN6LE-V

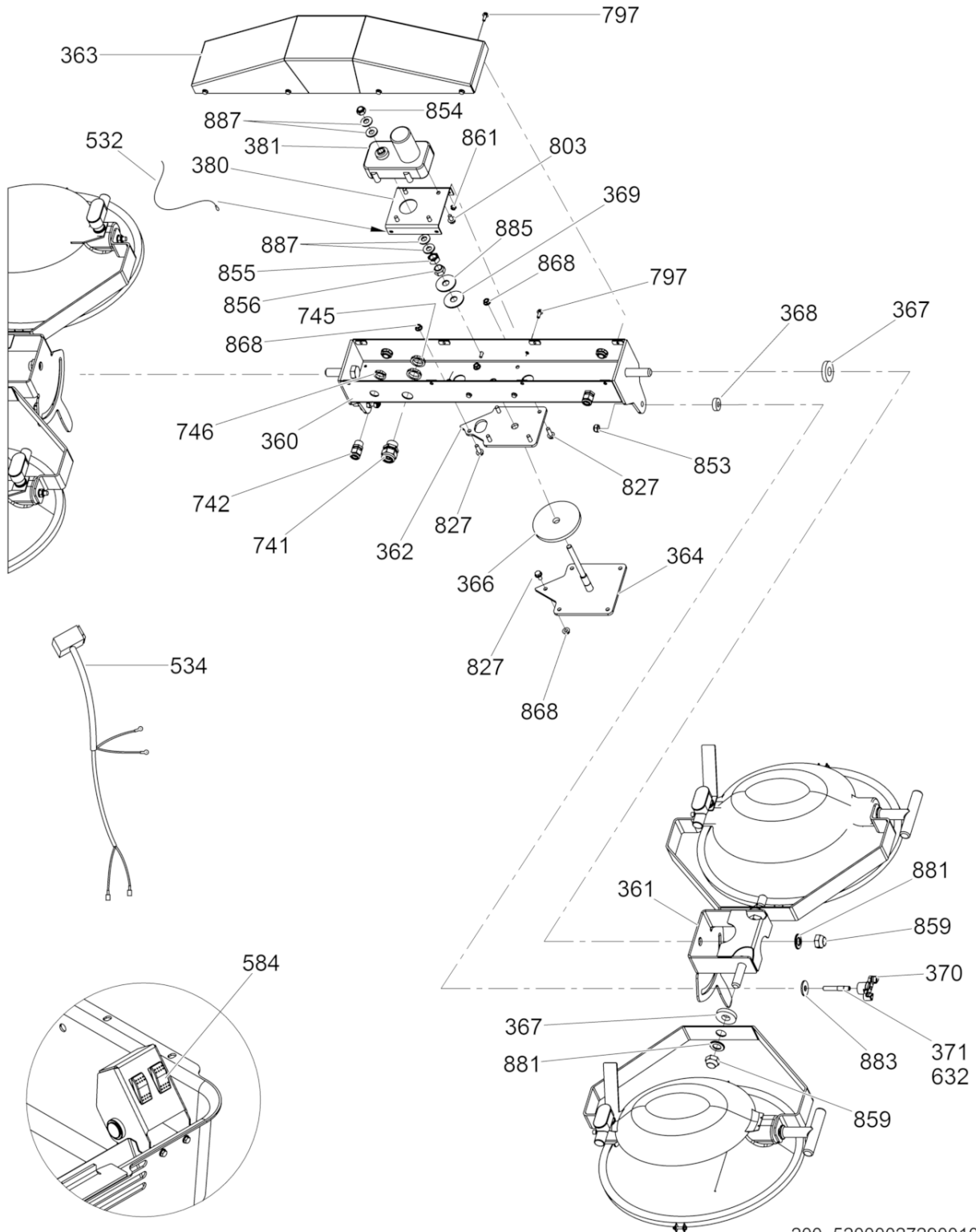

200_5200002729001001

Ref. Pos.	Part No. Artikel Nr.	Qty. St.	Description Beschreibung	Descripción Description	Measurem./Abm.	Norm
					Torque/Drehm.	Sealant Schmierstoff
360	5200002002	1	Support Halter	Soporte Attache		
361	5200002006	2	Bracket Konsole	Soporte Support		
362	5100021197	1	Plate Platte	Placa Plaque		
363	5100021198	1	Cover Deckel	Tapa Couvercle		
364	5200002345	1	Bracket Konsole	Soporte Support		
366	5200002025	1	Disc Scheibe	Disco Disque		
367	5200002026	6	Disc Scheibe	Disco Disque		
368	5200002350	2	Disc Scheibe	Disco Disque		
369	5200002027	1	Disc Scheibe	Disco Disque		
370	5000119406	2	Knob Griff	Empuñadura Poignée		
371	5000117816	2	Stud Gewindebolzen	Perno prisionero Goujon	M10	
380	5200002024	1	Bracket Konsole	Soporte Support		
381	5200002033	1	Motor Motor	Motor Moteur	12VDC	
532	5200009665	1	Wire-ground Erdungsdraht	Alambre a tierra Fil de masse		
534	5200002188	1	Wiring harness Kabelbaum	Conjunto de cables Harnais de câbles électriques		
584	5200002182	1	Switch Schalter	Interruptor Interrupteur		
741	5000165222	1	Cord grip Zugentlastung	Alivio de esfuerzos Effort à la décharge	3/4in NPT	
742	5000165223	2	Cord grip Zugentlastung	Alivio de esfuerzos Effort à la décharge	1/2in NPT	
745	5000176419	4	Lock nut Sicherungsmutter	Contratuerca Contre-écrou	3/4in	
746	5000166459	4	Lock nut Sicherungsmutter	Contratuerca Contre-écrou		
797	5000028949	4	Screw Schraube	Tornillo Vis	M6 x 16 10Nm/7ft.lbs	
803	5200002038	4	Screw Schraube	Tornillo Vis	5/16	
827	5000155213	2	Screw Schraube	Tornillo Vis	M8 x 25 25Nm/18ft.lbs	
853	5000010365	2	Lock nut Sicherungsmutter	Contratuerca Contre-écrou	M10	DIN980
854	5000010366	1	Hexagon nut Sechskantmutter	Tuerca hexagonal Écrou hexagonal	M12X1.75	DIN985

Option-Power Rotator
 Sonderzubehör-Drehvorrichtung
 Opción-Dispositivo giratorio
 Option-Appareil rotatif

LTN6LE-V

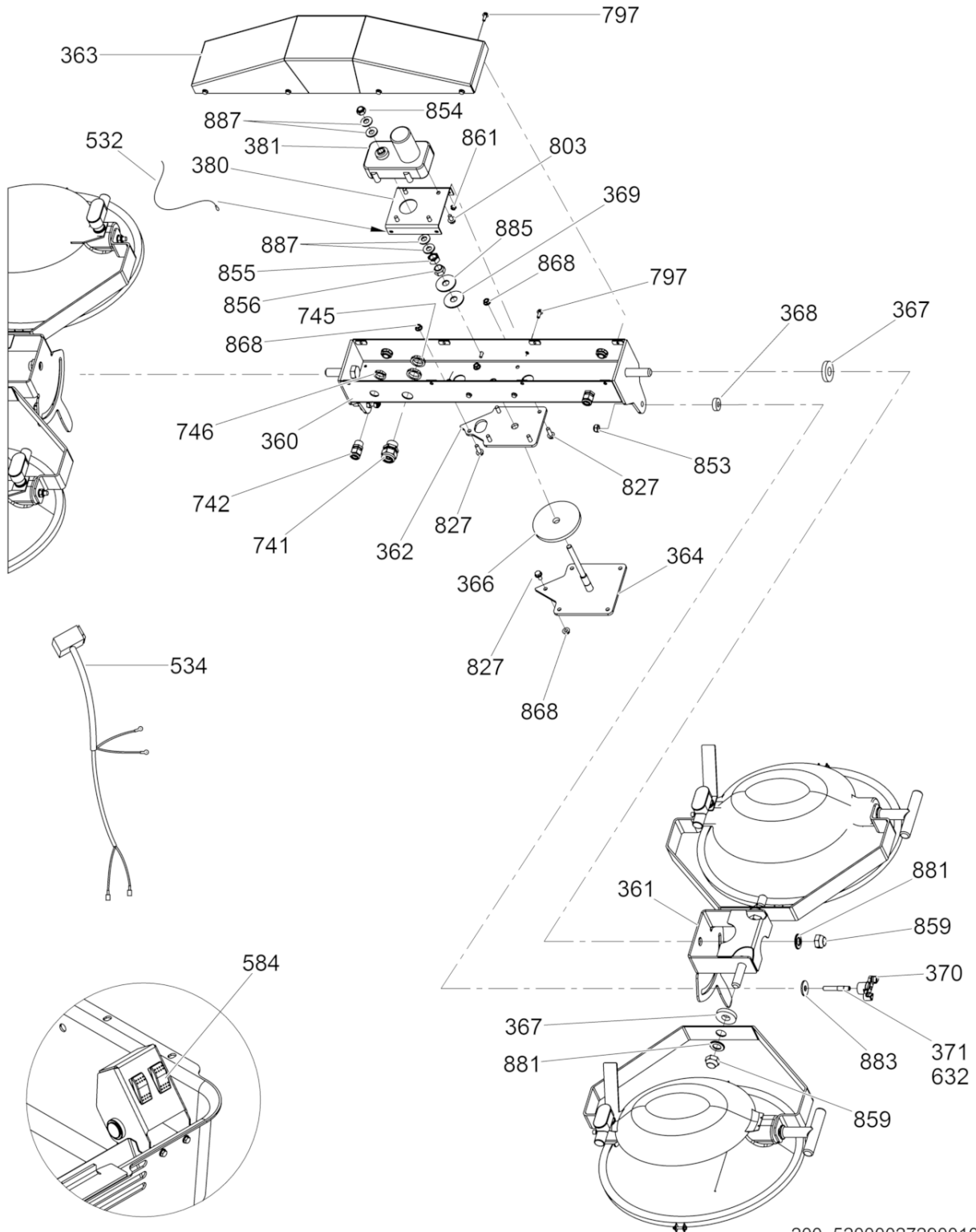

200_5200002729001001

Ref. Pos.	Part No. Artikel Nr.	Qty. St.	Description Beschreibung	Descripción Description	Measurement./Abm.	Norm
					Torque/Drehm.	Sealant Schmierstoff
855	5000010886	1	Hexagon nut Sechskantmutter	Tuerca hexagonal Écrou hexagonal	M16	DIN934
859	5000017088	4	Lock nut Sicherungsmutter	Contratuerca Contre-écrou	M20	
861	5000029117	4	Lock nut Sicherungsmutter	Contratuerca Contre-écrou	M6	
868	5000030066	2	Locknut Sechskantmutter	Contratuerca Contre-écrou	M8	
881	5000010616	4	Flat washer Scheibe	Arandela Rondelle		
883	5000010376	2	Flat washer Scheibe	Arandela Rondelle	A13	DIN9021
885	5000031186	1	Flat washer Scheibe	Arandela Rondelle	A17	DIN9021
887	5000031565	4	Lockwasher Spannscheibe	Arandela elástica Rondelle de ressort	12	DIN6796

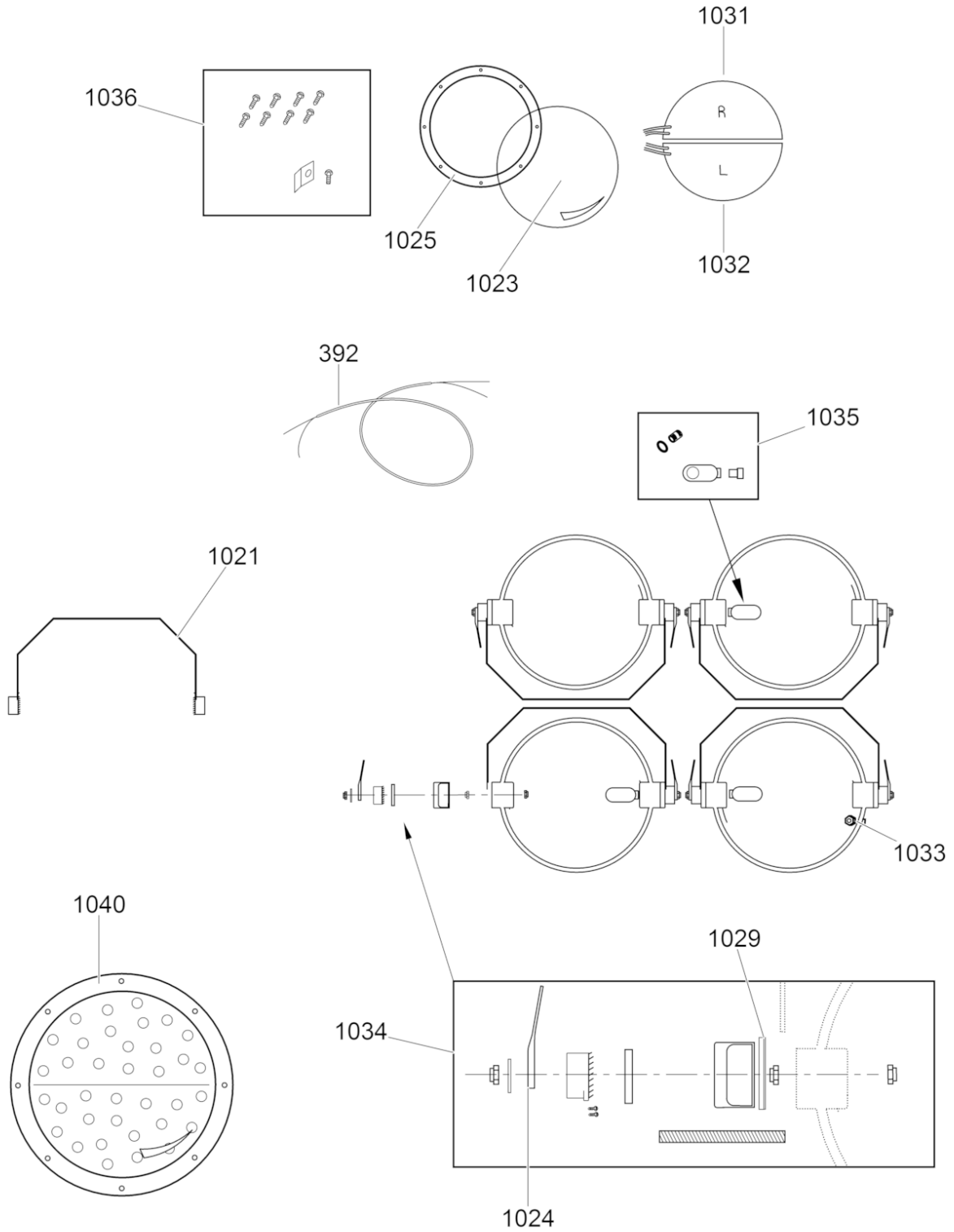

200_5200022505001001

Ref. Pos.	Part No. Artikel Nr.	Qty. St.	Description Beschreibung	Descripción Description	Measurem./Abm.	Norm
					Torque/Drehm.	Sealant Schmierstoff
392	5200018846	4	Cable harness Kabelbaum	Disp. del cable de elevación Faisceau de câbles		
1021	5200022328	4	Yoke Gabel	Horquilla Extrémité à chape		
1023	5200022317	4	Lens Linse	Lentes Lentille		
1024	5200022332	8	Handle Handgriff	Manija Poignée		
1025	5200022316	4	Frame top Abdeckung, oben	Parte superior de la cubierta Dessus de couvercle		
1029	5200022339	8	Gasket Dichtung	Junta Joint		
1031	5200022341	4	Circuit board, right Schaltplatte	Tablero de circuitos Carte de circuit		
1032	5200022340	4	Circuit board, left Schaltplatte	Tablero de circuitos Carte de circuit		
1033	5200022327	4	Valve Ventil	Válvula Soupape		
1034	5200022507	4	Kit-lock assembly Satz-scherung	Juego-seguro Jeu-errou		
1035	5200022508	4	Kit - junction box Satz - Abzweigkasten	Juego - caja de distribución Jeu - boîte de tirage		
1036	5200022509	4	Lens Hardware Kit Kleinteilesatz	Juego de piezas pequeñas Jeu de pièces		
1040	5200022505	4	LED Light cpl. Beleuchtungseinrichtung - LED	Artefactos compl. - LED Projecteurs compl. - DEL		

Tower section 0
Turm, Teil 0
Sección de la torre - 0
Section de la tour - 0

LTN6LE-V

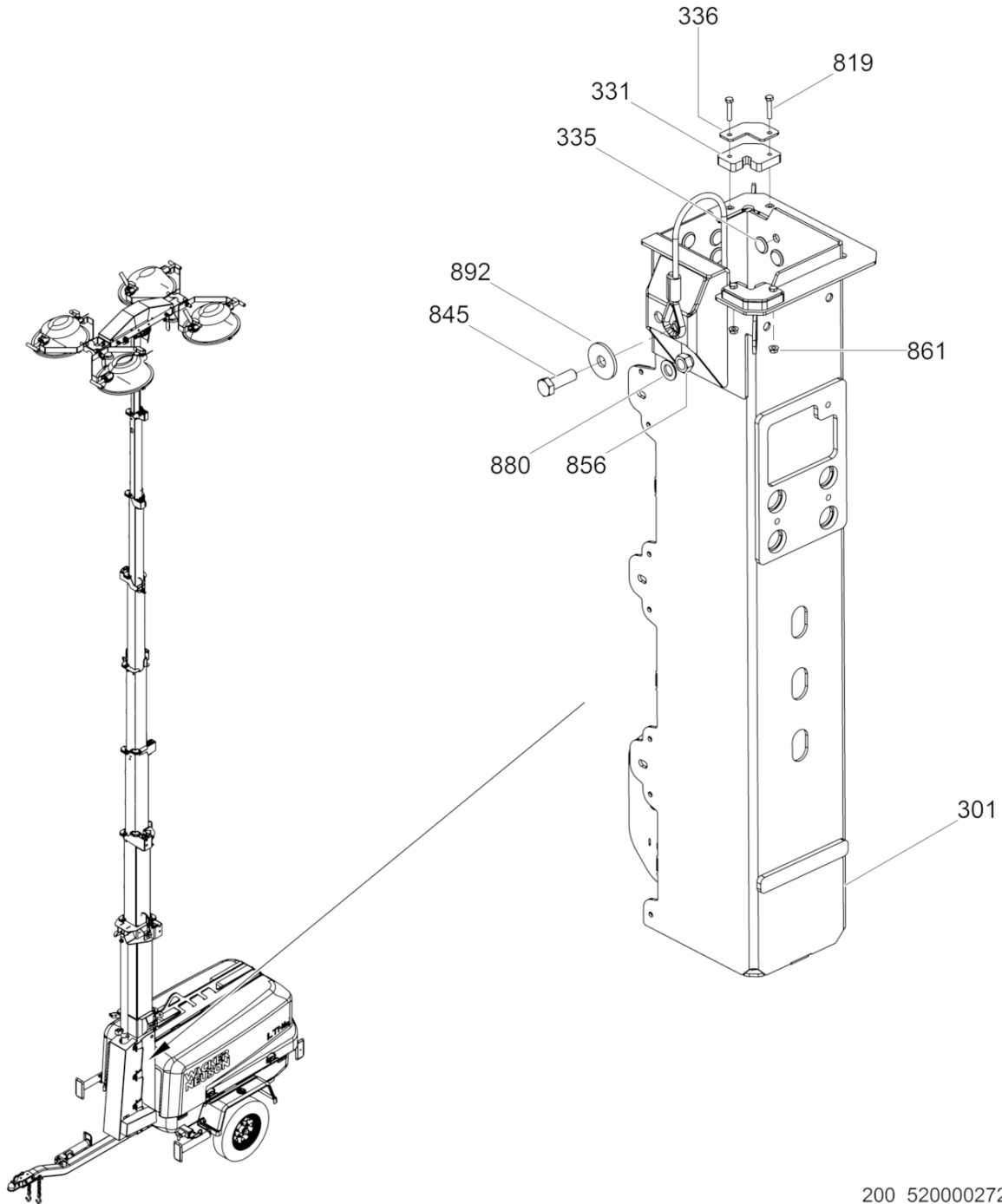

200_5200002720100050

Ref. Pos.	Part No. Artikel Nr.	Qty. St.	Description Beschreibung	Descripción Description	Measurem./Abm.	Norm
					Torque/Drehm.	Sealant Schmierstoff
301	5200009816	1	Tower Tube Turmröhre	Tubo de la torre Tube de la tour		
331	5200000379	2	Guide Führung	Guía Guide		
335	5200003228	16	Guide Führung	Guía Guide		
336	5200009981	2	Guide plate Führungsplatte	Placa de guía Plaque de guide		
819	5000011468	4	Hexagonal head cap screw Sechskantschraube	Tornillo hexagonal Vis à tête hexagonale	M6 x 30 10Nm/7ft.lbs	DIN933
845	5000011374	1	Hexagonal head cap screw Sechskantschraube	Tornillo hexagonal Vis à tête hexagonale	M16 x 50 180Nm/133ft.lbs	DIN931
856	5000013496	1	Hexagon nut Sechskantmutter	Tuerca hexagonal Écrou hexagonal	M16	DIN985
861	5000029117	4	Lock nut Sicherungsmutter	Contratuerca Contre-écrou	M6	
880	5000010618	1	Flat washer Scheibe	Arandela Rondelle	16	ISO7090
892	5200008557	1	Washer Scheibe	Arandela Rondelle		

Tower section 1
Turm, Teil 1
Sección de la torre - 1
Section de la tour - 1

LTN6LE-V

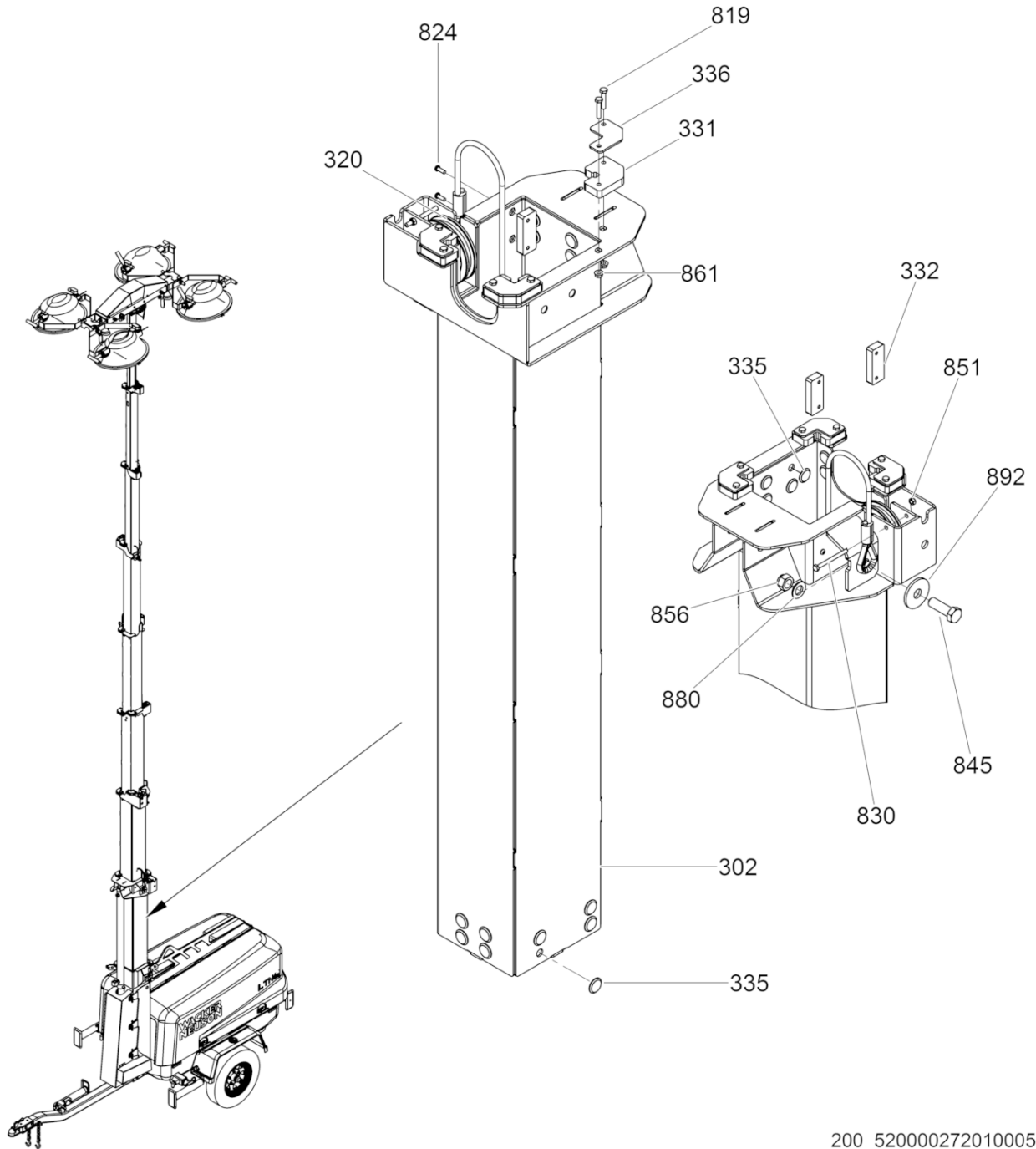

200_5200002720100051

Ref. Pos.	Part No. Artikel Nr.	Qty. St.	Description Beschreibung	Descripción Description	Measurement./Abm.	Norm
					Torque/Drehm.	Sealant Schmierstoff
302	5200009358	1	Tower Tube Turmröhre	Tubo de la torre Tube de la tour		
320	5200002049	1	Pulley Scheibe	Polea Poulie		
331	5200000379	3	Guide Führung	Guía Guide		
332	5200000387	2	Guide Führung	Guía Guide		
335	5200003229	20	Guide Führung	Guía Guide		
336	5200009981	3	Guide plate Führungsplatte	Placa de guía Plaque de guide		
819	5000011468	6	Hexagonal head cap screw Sechskantschraube	Tornillo hexagonal Vis à tête hexagonale	M6 x 30 10Nm/7ft.lbs	DIN933
824	5200011740	4	Screw Schraube	Tornillo Vis	M5 x 14	
830	5000087698	1	Hexagonal head cap screw Sechskantschraube	Tornillo hexagonal Boulon à tête hexagonale	M6 x 70	
845	5000011374	1	Hexagonal head cap screw Sechskantschraube	Tornillo hexagonal Vis à tête hexagonale	M16 x 50 180Nm/133ft.lbs	DIN931
851	5000010368	1	Hexagon nut Sechskantmutter	Tuerca hexagonal Écrou hexagonal	M6	DIN985
856	5000013496	1	Hexagon nut Sechskantmutter	Tuerca hexagonal Écrou hexagonal	M16	DIN985
861	5000029117	6	Lock nut Sicherungsmutter	Contratuerca Contre-écrou	M6	
880	5000010618	1	Flat washer Scheibe	Arandela Rondelle	16	ISO7090
892	5200008557	1	Washer Scheibe	Arandela Rondelle		

Tower section 2

Turm, Teil 2

Sección de la torre - 2

Section de la tour - 2

LTN6LE-V

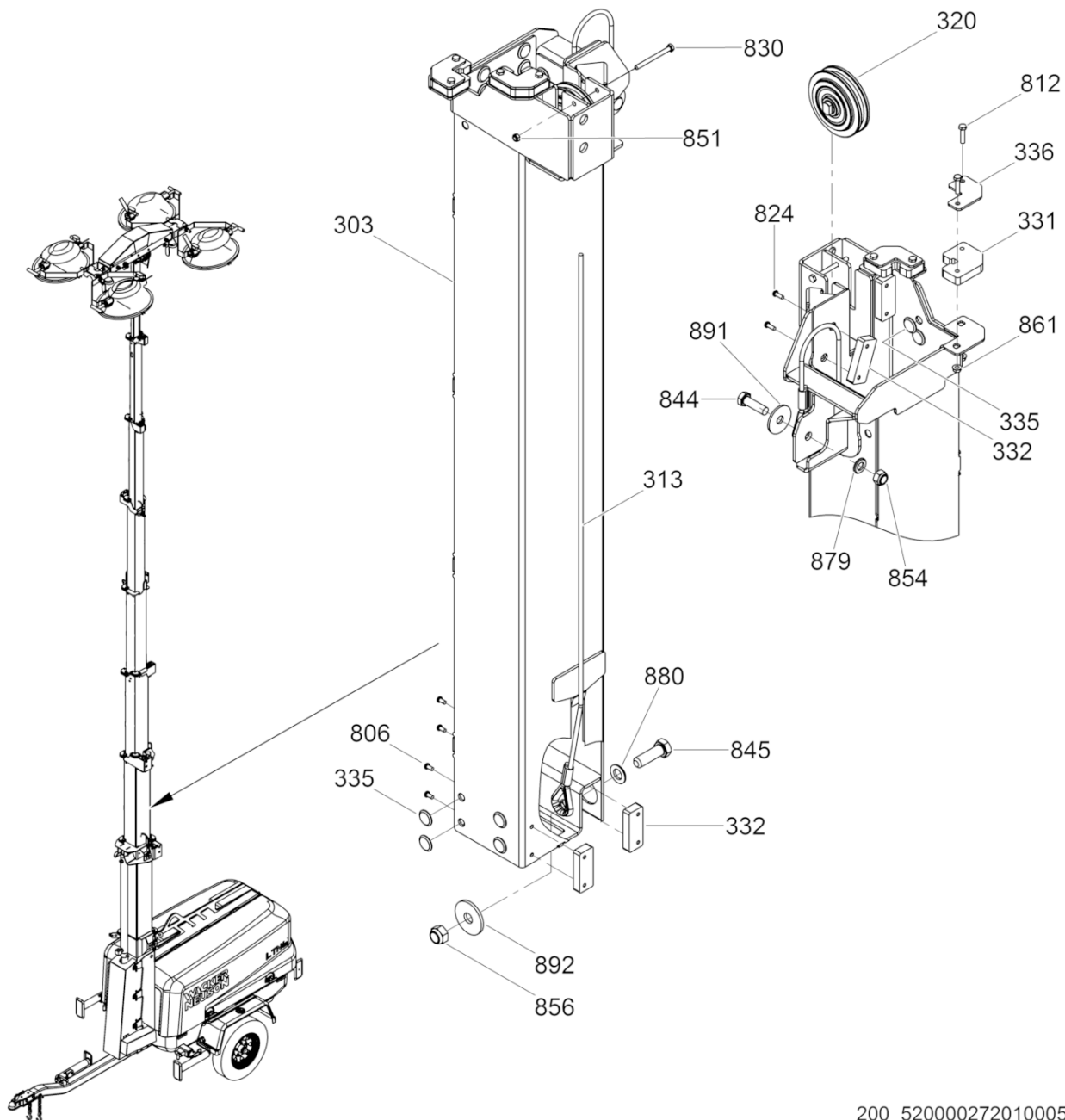

200_5200002720100052

Ref. Pos.	Part No. Artikel Nr.	Qty. St.	Description Beschreibung	Descripción Description	Measurement./Abm.	Norm
					Torque/Drehm.	Sealant Schmierstoff
303	5200009356	1	Tower Tube Turmröhre	Tubo de la torre Tube de la tour		
313	5200002099	1	Cable Kabel	Cable Câble	5/16in	
320	5200002049	1	Pulley Scheibe	Polea Poulie		
331	5200000379	2	Guide Führung	Guía Guide		
332	5200000387	4	Guide Führung	Guía Guide		
335	5200003228	17	Guide Führung	Guía Guide		
336	5200009981	2	Guide plate Führungsplatte	Placa de guía Plaque de guide		
806	5000165226	4	Screw Schraube	Tornillo Vis	M5 x 10	
812	5000011469	4	Hexagonal head cap screw Sechskantschraube	Tornillo hexagonal Vis à tête hexagonale	M6 x 25 10Nm/7ft.lbs	DIN933
824	5200011740	4	Screw Schraube	Tornillo Vis	M5 x 14	
830	5000087698	1	Hexagonal head cap screw Sechskantschraube	Tornillo hexagonal Boulon à tête hexagonale	M6 x 70	
844	5000011421	1	Hexagonal head cap screw Sechskantschraube	Tornillo hexagonal Vis à tête hexagonale	M12 x 40 83Nm/61ft.lbs	DIN933
845	5000011374	1	Hexagonal head cap screw Sechskantschraube	Tornillo hexagonal Vis à tête hexagonale	M16 x 50 180Nm/133ft.lbs	DIN931
851	5000010368	1	Hexagon nut Sechskantmutter	Tuerca hexagonal Écrou hexagonal	M6	DIN985
854	5000010366	1	Hexagon nut Sechskantmutter	Tuerca hexagonal Écrou hexagonal	M12X1.75	DIN985
856	5000013496	1	Hexagon nut Sechskantmutter	Tuerca hexagonal Écrou hexagonal	M16	DIN985
861	5000029117	4	Lock nut Sicherungsmutter	Contratuerca Contre-écrou	M6	
879	5000010620	1	Flat washer Scheibe	Arandela Rondelle	12	ISO7090
880	5000010618	1	Flat washer Scheibe	Arandela Rondelle	16	ISO7090
891	5200008556	1	Washer Scheibe	Arandela Rondelle	M12 x 45 x3	
892	5200008557	1	Washer Scheibe	Arandela Rondelle		

Tower section 3
Turm, Teil 3
Sección de la torre - 3
Section de la tour - 3

LTN6LE-V

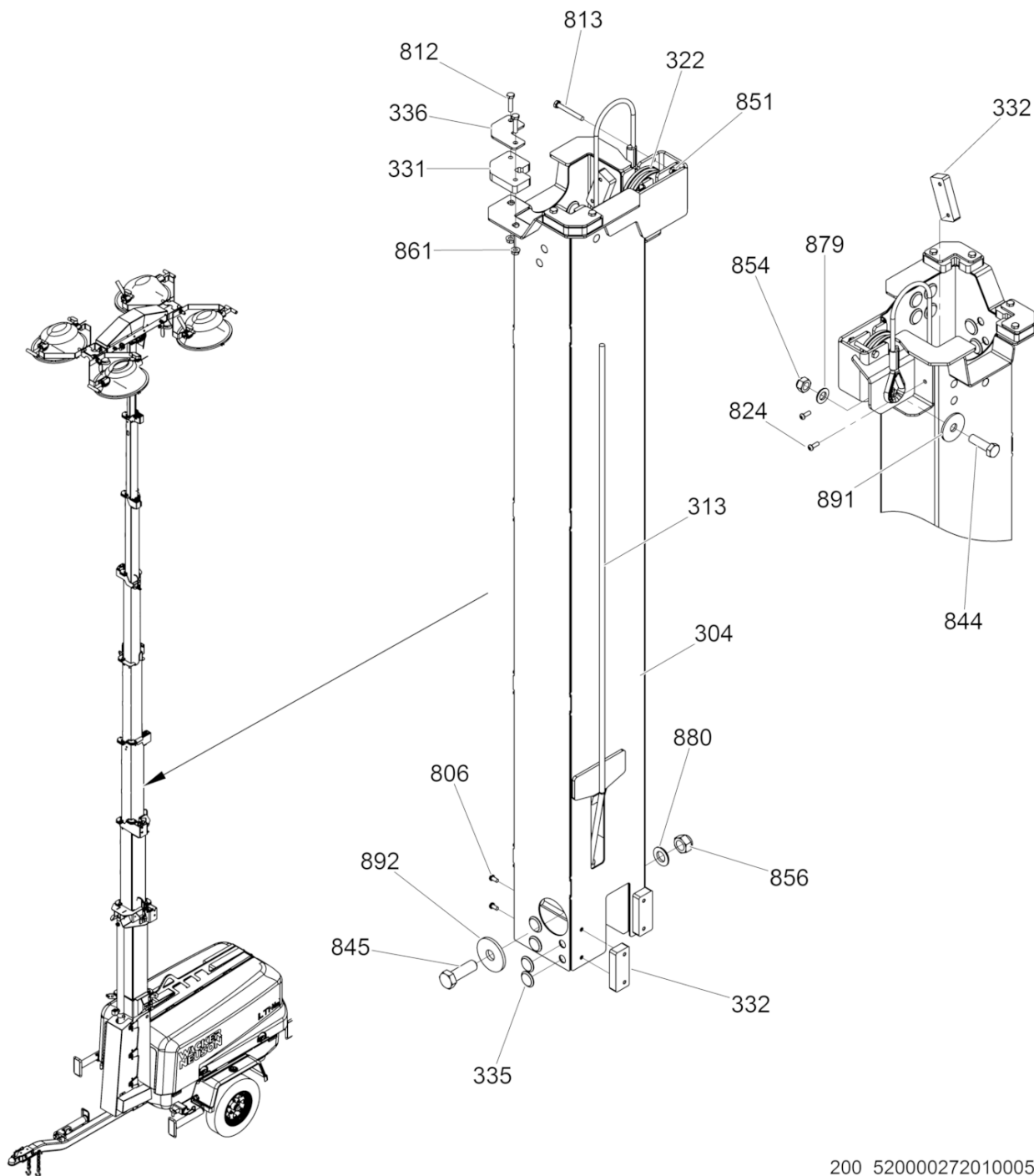

200_5200002720100053

Ref. Pos.	Part No. Artikel Nr.	Qty. St.	Description Beschreibung	Descripción Description	Measurement./Abm.	Norm
					Torque/Drehm.	Sealant Schmierstoff
304	5200009355	1	Tower Tube Turmröhre	Tubo de la torre Tube de la tour		
313	5200002099	1	Cable Kabel	Cable Câble	5/16in	
322	5200002051	1	Pulley Scheibe	Polea Poulie		
331	5200000379	2	Guide Führung	Guía Guide		
332	5200000387	3	Guide Führung	Guía Guide		
335	5200003229	14	Guide Führung	Guía Guide		
336	5200009981	2	Guide plate Führungsplatte	Placa de guía Plaque de guide		
806	5000165226	4	Screw Schraube	Tornillo Vis	M5 x 10	
813	5000011464	1	Hexagonal head cap screw Sechskantschraube	Tornillo hexagonal Vis à tête hexagonale	M6 x 50 10Nm/7ft.lbs	DIN933
824	5200011740	2	Screw Schraube	Tornillo Vis	M5 x 14	
844	5000011421	1	Hexagonal head cap screw Sechskantschraube	Tornillo hexagonal Vis à tête hexagonale	M12 x 40 83Nm/61ft.lbs	DIN933
845	5000011374	1	Hexagonal head cap screw Sechskantschraube	Tornillo hexagonal Vis à tête hexagonale	M16 x 50 180Nm/133ft.lbs	DIN931
851	5000010368	1	Hexagon nut Sechskantmutter	Tuerca hexagonal Écrou hexagonal	M6	DIN985
854	5000010366	1	Hexagon nut Sechskantmutter	Tuerca hexagonal Écrou hexagonal	M12X1.75	DIN985
856	5000013496	1	Hexagon nut Sechskantmutter	Tuerca hexagonal Écrou hexagonal	M16	DIN985
861	5000029117	4	Lock nut Sicherungsmutter	Contratuerca Contre-écrou	M6	
879	5000010620	1	Flat washer Scheibe	Arandela Rondelle	12	ISO7090
880	5000010618	1	Flat washer Scheibe	Arandela Rondelle	16	ISO7090
891	5200008556	1	Washer Scheibe	Arandela Rondelle	M12 x 45 x3	
892	5200008557	1	Washer Scheibe	Arandela Rondelle		

Tower section 4
 Turm, Teil 4
 Sección de la torre - 4
 Section de la tour - 4

LTN6LE-V

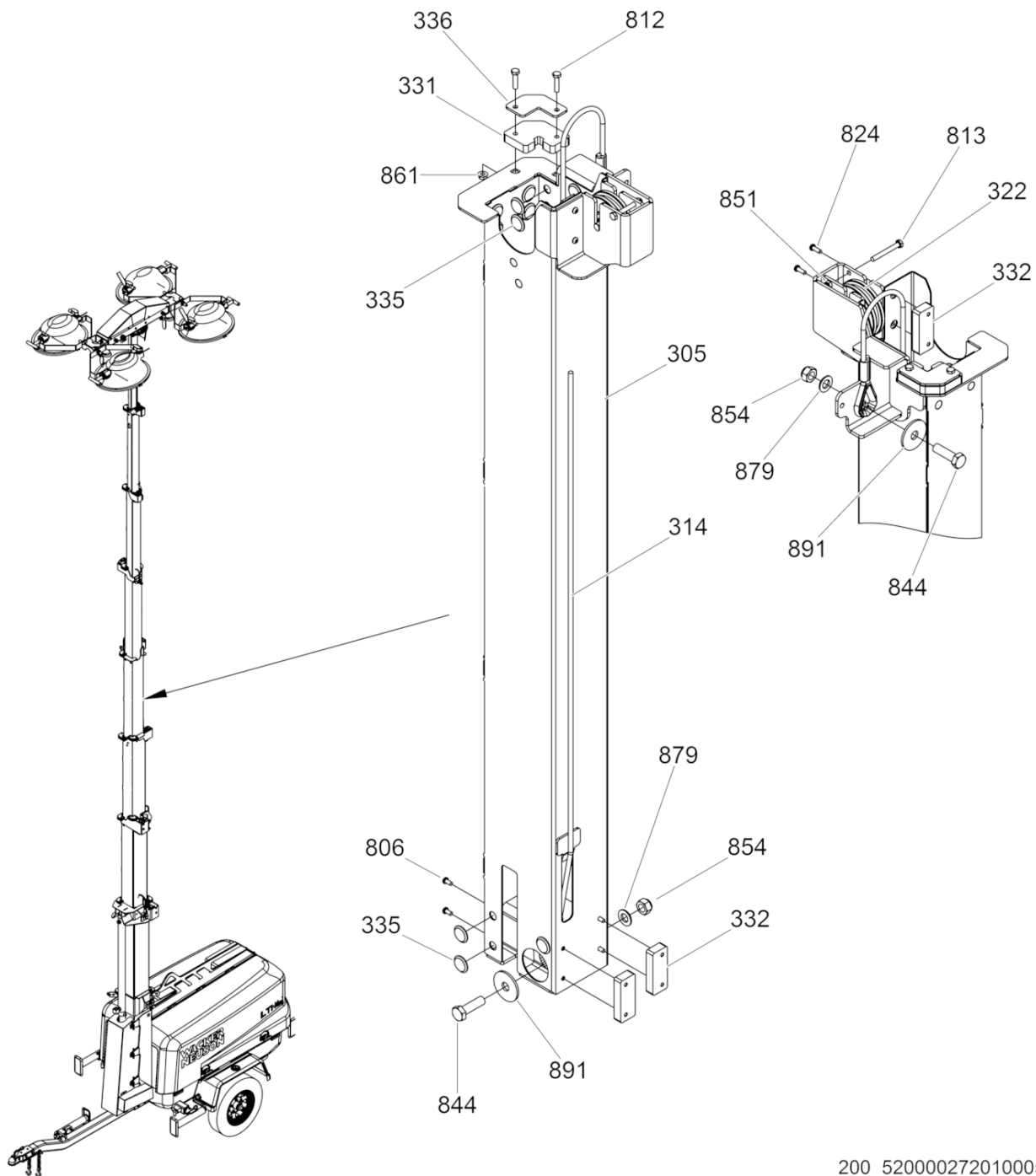

200_5200002720100054

Ref. Pos.	Part No. Artikel Nr.	Qty. St.	Description Beschreibung	Descripción Description	Measurem./Abm.	Norm
					Torque/Drehm.	Sealant Schmierstoff
305	5200009342	1	Tower Tube Turmröhre	Tubo de la torre Tube de la tour		
314	5200002130	1	Cable Kabel	Cable Câble	1/4in	
322	5200002051	1	Pulley Scheibe	Polea Poulie		
331	5200000379	1	Guide Führung	Guía Guide		
332	5200000387	3	Guide Führung	Guía Guide		
335	5200003229	21	Guide Führung	Guía Guide		
336	5200009981	1	Guide plate Führungsplatte	Placa de guía Plaque de guide		
806	5000165226	4	Screw Schraube	Tornillo Vis	M5 x 10	
812	5000011469	2	Hexagonal head cap screw Sechskantschraube	Tornillo hexagonal Vis à tête hexagonale	M6 x 25 10Nm/7ft.lbs	DIN933
813	5000011464	1	Hexagonal head cap screw Sechskantschraube	Tornillo hexagonal Vis à tête hexagonale	M6 x 50 10Nm/7ft.lbs	DIN933
824	5200011740	2	Screw Schraube	Tornillo Vis	M5 x 14	
844	5000011421	2	Hexagonal head cap screw Sechskantschraube	Tornillo hexagonal Vis à tête hexagonale	M12 x 40 83Nm/61ft.lbs	DIN933
851	5000010368	1	Hexagon nut Sechskantmutter	Tuerca hexagonal Écrou hexagonal	M6	DIN985
854	5000010366	2	Hexagon nut Sechskantmutter	Tuerca hexagonal Écrou hexagonal	M12X1.75	DIN985
861	5000029117	2	Lock nut Sicherungsmutter	Contratuerca Contre-écrou	M6	
879	5000010620	2	Flat washer Scheibe	Arandela Rondelle	12	ISO7090
891	5200008556	2	Washer Scheibe	Arandela Rondelle	M12 x 45 x3	

Tower section 5
Turm, Teil 5
Sección de la torre - 5
Section de la tour - 5

LTN6LE-V

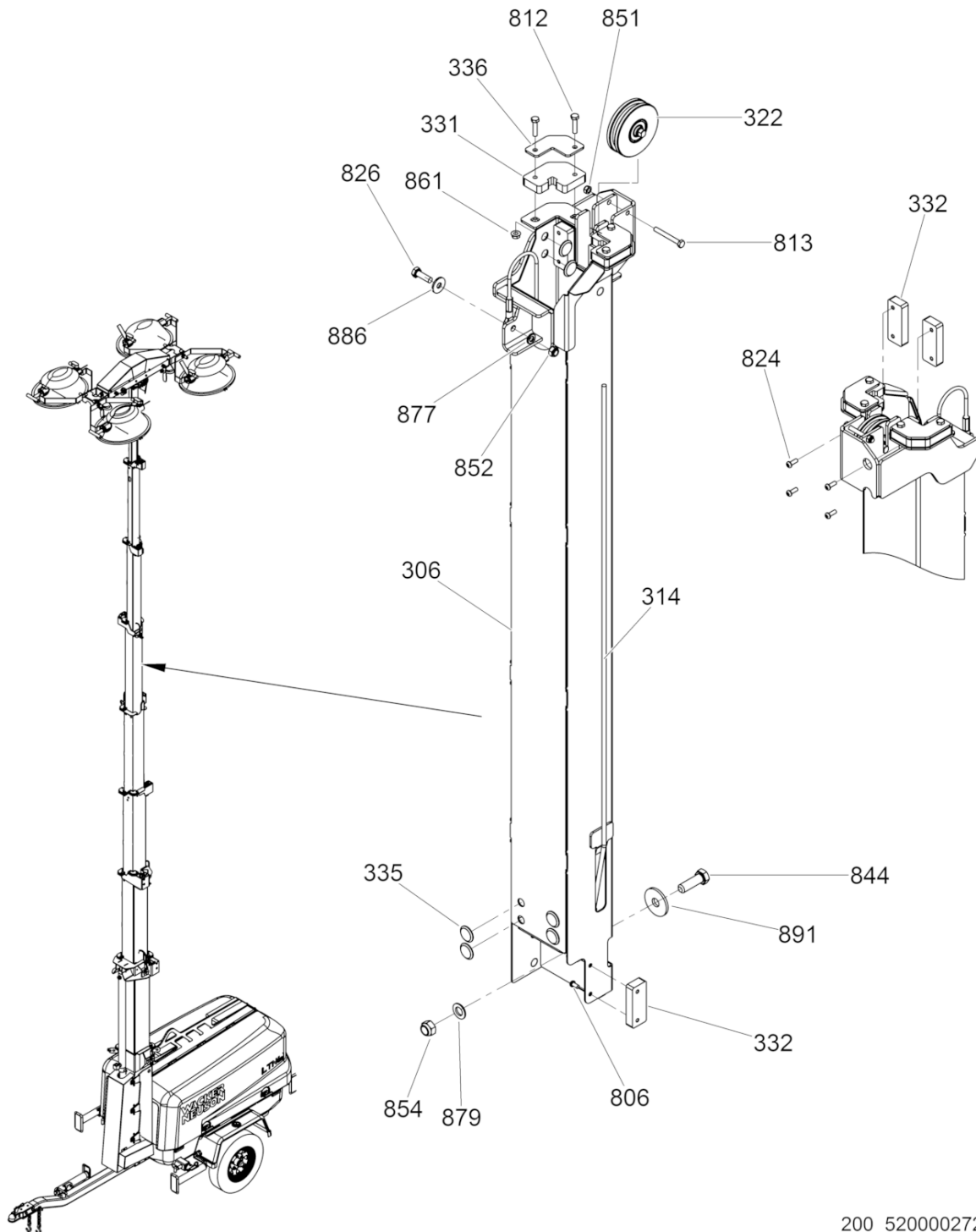

200_5200002720100055

Ref. Pos.	Part No. Artikel Nr.	Qty. St.	Description Beschreibung	Descripción Description	Measurement./Abm.	Norm
					Torque/Drehm.	Sealant Schmierstoff
306	5200009339	1	Tower Tube Turmröhre	Tubo de la torre Tube de la tour		
314	5200002130	1	Cable Kabel	Cable Câble	1/4in	
322	5200002051	1	Pulley Scheibe	Polea Poulie		
331	5200000379	2	Guide Führung	Guía Guide		
332	5200000387	3	Guide Führung	Guía Guide		
335	5200003229	17	Guide Führung	Guía Guide		
336	5200009981	2	Guide plate Führungsplatte	Placa de guía Plaque de guide		
806	5000165226	1	Screw Schraube	Tornillo Vis	M5 x 10	
812	5000011469	4	Hexagonal head cap screw Sechskantschraube	Tornillo hexagonal Vis à tête hexagonale	M6 x 25 10Nm/7ft.lbs	DIN933
824	5200011740	4	Screw Schraube	Tornillo Vis	M5 x 14	
826	5000011457	1	Hexagonal head cap screw Sechskantschraube	Tornillo hexagonal Vis à tête hexagonale	M8 x 25 24Nm/18ft.lbs	DIN933
844	5000011421	1	Hexagonal head cap screw Sechskantschraube	Tornillo hexagonal Vis à tête hexagonale	M12 x 40 83Nm/61ft.lbs	DIN933
851	5000010368	1	Hexagon nut Sechskantmutter	Tuerca hexagonal Écrou hexagonal	M6	DIN985
854	5000010366	1	Hexagon nut Sechskantmutter	Tuerca hexagonal Écrou hexagonal	M12X1.75	DIN985
861	5000029117	4	Lock nut Sicherungsmutter	Contratuerca Contre-écrou	M6	
877	5000010622	1	Flat washer Scheibe	Arandela Rondelle		
879	5000010620	1	Flat washer Scheibe	Arandela Rondelle	12	ISO7090
886	5000010374	1	Flat washer Scheibe	Arandela Rondelle		
891	5200008556	1	Washer Scheibe	Arandela Rondelle	M12 x 45 x3	

Tower section 6
Turm, Teil 6
Sección de la torre - 6
Section de la tour - 6

LTN6LE-V

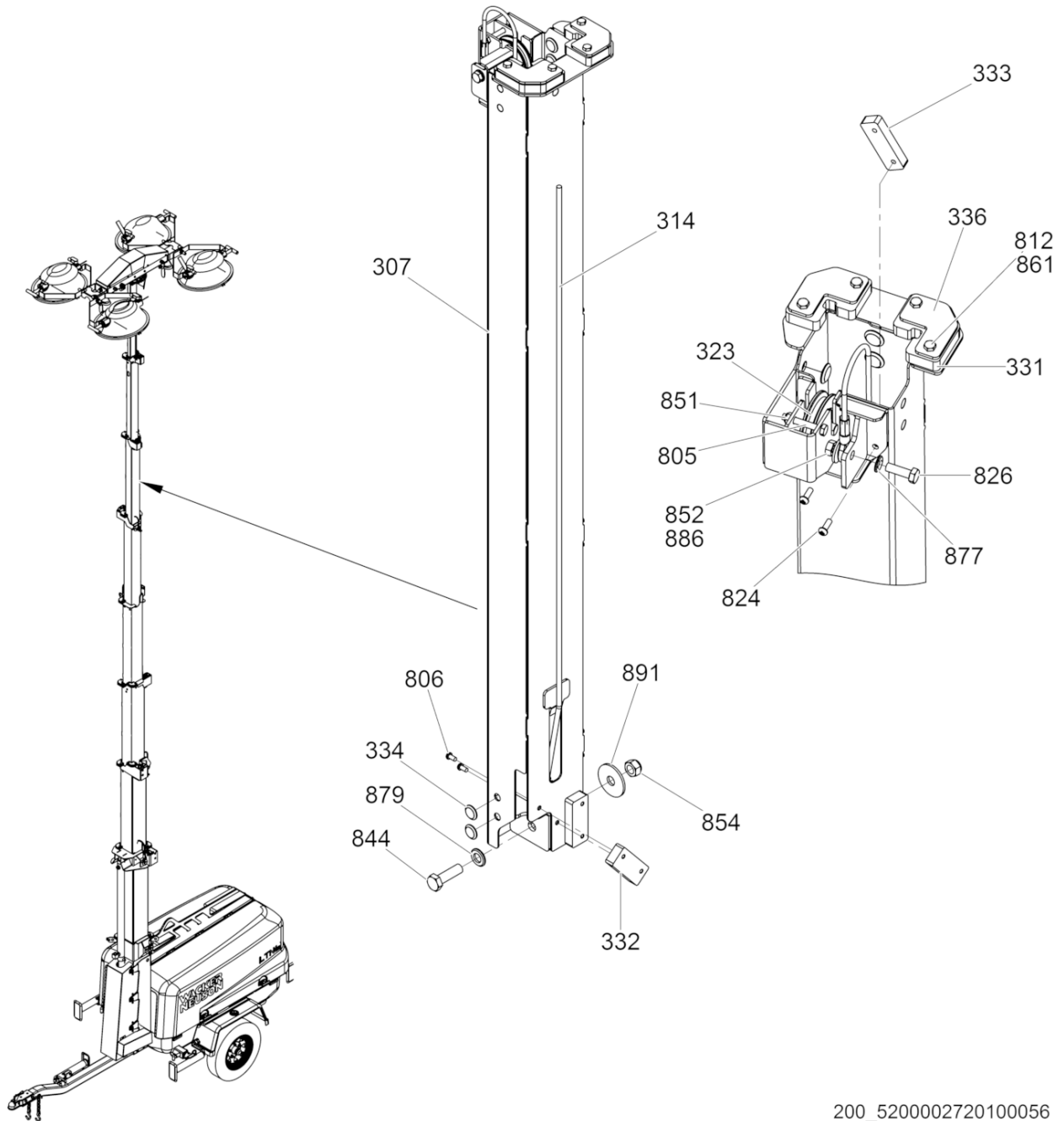

200_5200002720100056

Ref. Pos.	Part No. Artikel Nr.	Qty. St.	Description Beschreibung	Descripción Description	Measurem./Abm.	Norm
					Torque/Drehm.	Sealant Schmierstoff
307	5200009336	1	Tower Tube Turmröhre	Tubo de la torre Tube de la tour		
314	5200002130	1	Cable Kabel	Cable Câble	1/4in	
323	5200002052	1	Pulley Scheibe	Polea Poulie		
331	5200000379	2	Guide Führung	Guía Guide		
332	5200000387	2	Guide Führung	Guía Guide		
333	5200003227	1	Guide Führung	Guía Guide		
334	5200003228	12	Guide Führung	Guía Guide		
336	5200009981	2	Guide plate Führungsplatte	Placa de guía Plaque de guide		
805	5000011466	1	Hexagonal head cap screw Sechskantschraube	Tornillo hexagonal Vis à tête hexagonale	M6 x 40 10Nm/7ft.lbs	DIN933
806	5000165226	4	Screw Schraube	Tornillo Vis	M5 x 10	
812	5000011469	4	Hexagonal head cap screw Sechskantschraube	Tornillo hexagonal Vis à tête hexagonale	M6 x 25 10Nm/7ft.lbs	DIN933
824	5200011740	2	Screw Schraube	Tornillo Vis	M5 x 14 24Nm/18ft.lbs	
826	5000011457	1	Hexagonal head cap screw Sechskantschraube	Tornillo hexagonal Vis à tête hexagonale	M8 x 25 24Nm/18ft.lbs	DIN933
844	5000011421	1	Hexagonal head cap screw Sechskantschraube	Tornillo hexagonal Vis à tête hexagonale	M12 x 40 83Nm/61ft.lbs	DIN933
851	5000010368	1	Hexagon nut Sechskantmutter	Tuerca hexagonal Écrou hexagonal	M6	DIN985
852	5000010367	1	Hexagon nut Sechskantmutter	Tuerca hexagonal Écrou hexagonal	M8	DIN985
854	5000010366	1	Hexagon nut Sechskantmutter	Tuerca hexagonal Écrou hexagonal	M12X1.75	DIN985
877	5000010622	1	Flat washer Scheibe	Arandela Rondelle		
879	5000010620	1	Flat washer Scheibe	Arandela Rondelle	12	ISO7090
886	5000010374	1	Flat washer Scheibe	Arandela Rondelle		
891	5200008556	1	Washer Scheibe	Arandela Rondelle	M12 x 45 x3	

Tower section 7
 Turm, Teil 7
 Sección de la torre - 7
 Section de la tour - 7

LTN6LE-V

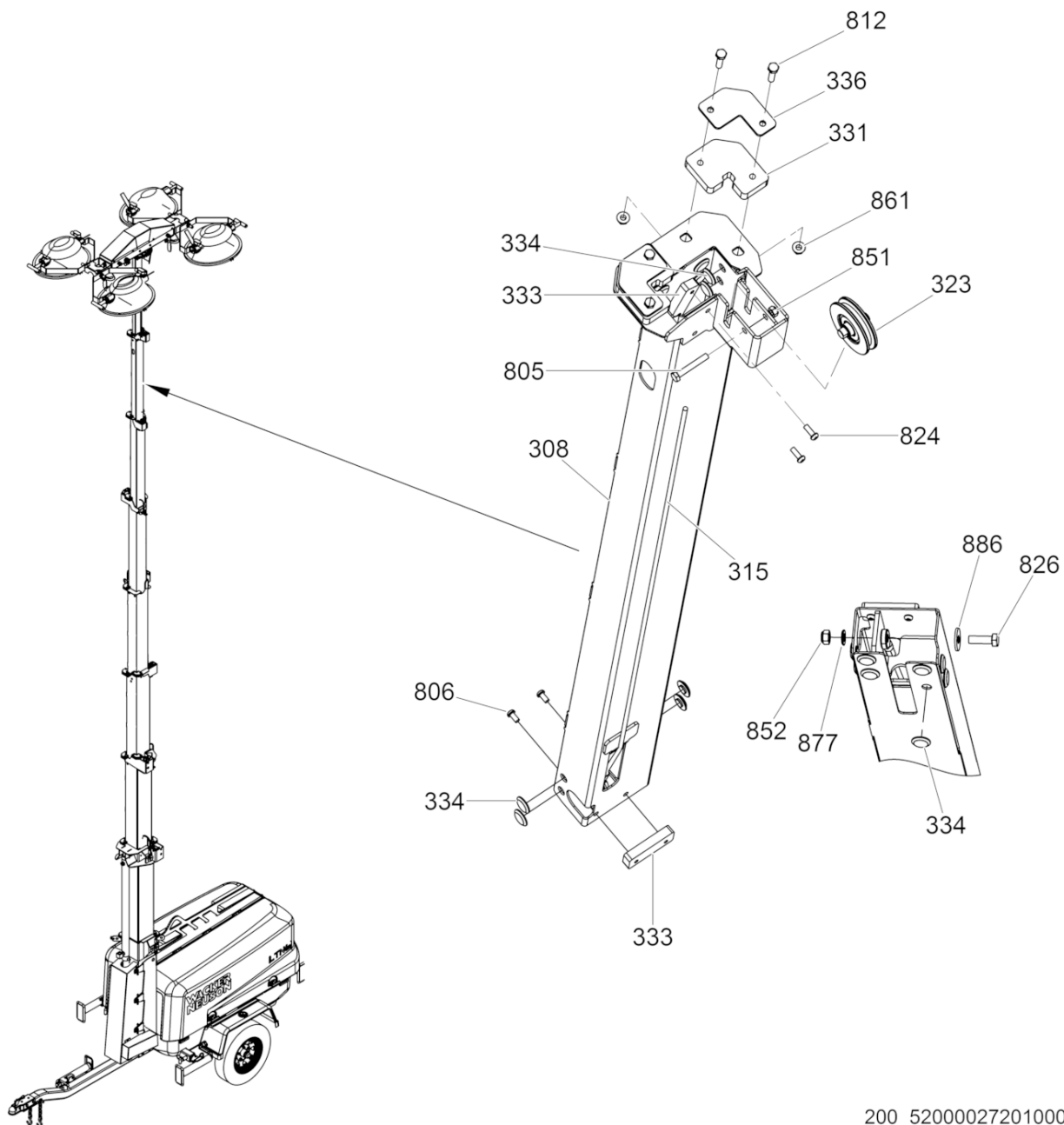

200_5200002720100057

Ref. Pos.	Part No. Artikel Nr.	Qty. St.	Description Beschreibung	Descripción Description	Measurement./Abm.	Norm
					Torque/Drehm.	Sealant Schmierstoff
308	5200009334	1	Tower Tube Turmröhre	Tubo de la torre Tube de la tour		
315	5200002131	1	Cable Kabel	Cable Câble	3/16in	
323	5200002052	1	Pulley Scheibe	Polea Poulie		
331	5200000379	2	Guide Führung	Guía Guide		
333	5200003227	2	Guide Führung	Guía Guide		
334	5200003228	16	Guide Führung	Guía Guide		
336	5200009981	2	Guide plate Führungsplatte	Placa de guía Plaque de guide		
805	5000011466	1	Hexagonal head cap screw Sechskantschraube	Tornillo hexagonal Vis à tête hexagonale	M6 x 40 10Nm/7ft.lbs	DIN933
806	5000165226	2	Screw Schraube	Tornillo Vis	M5 x 10	
812	5000011469	4	Hexagonal head cap screw Sechskantschraube	Tornillo hexagonal Vis à tête hexagonale	M6 x 25 10Nm/7ft.lbs	DIN933
824	5200011740	2	Screw Schraube	Tornillo Vis	M5 x 14	
826	5000011457	1	Hexagonal head cap screw Sechskantschraube	Tornillo hexagonal Vis à tête hexagonale	M8 x 25 24Nm/18ft.lbs	DIN933
851	5000010368	1	Hexagon nut Sechskantmutter	Tuerca hexagonal Écrou hexagonal	M6	DIN985
852	5000010367	1	Hexagon nut Sechskantmutter	Tuerca hexagonal Écrou hexagonal	M8	DIN985
861	5000029117	4	Lock nut Sicherungsmutter	Contratuerca Contre-écrou	M6	
877	5000010622	1	Flat washer Scheibe	Arandela Rondelle		
886	5000010374	1	Flat washer Scheibe	Arandela Rondelle		

Tower section 8
Turm, Teil 8
Sección de la torre - 8
Section de la tour - 8

LTN6LE-V

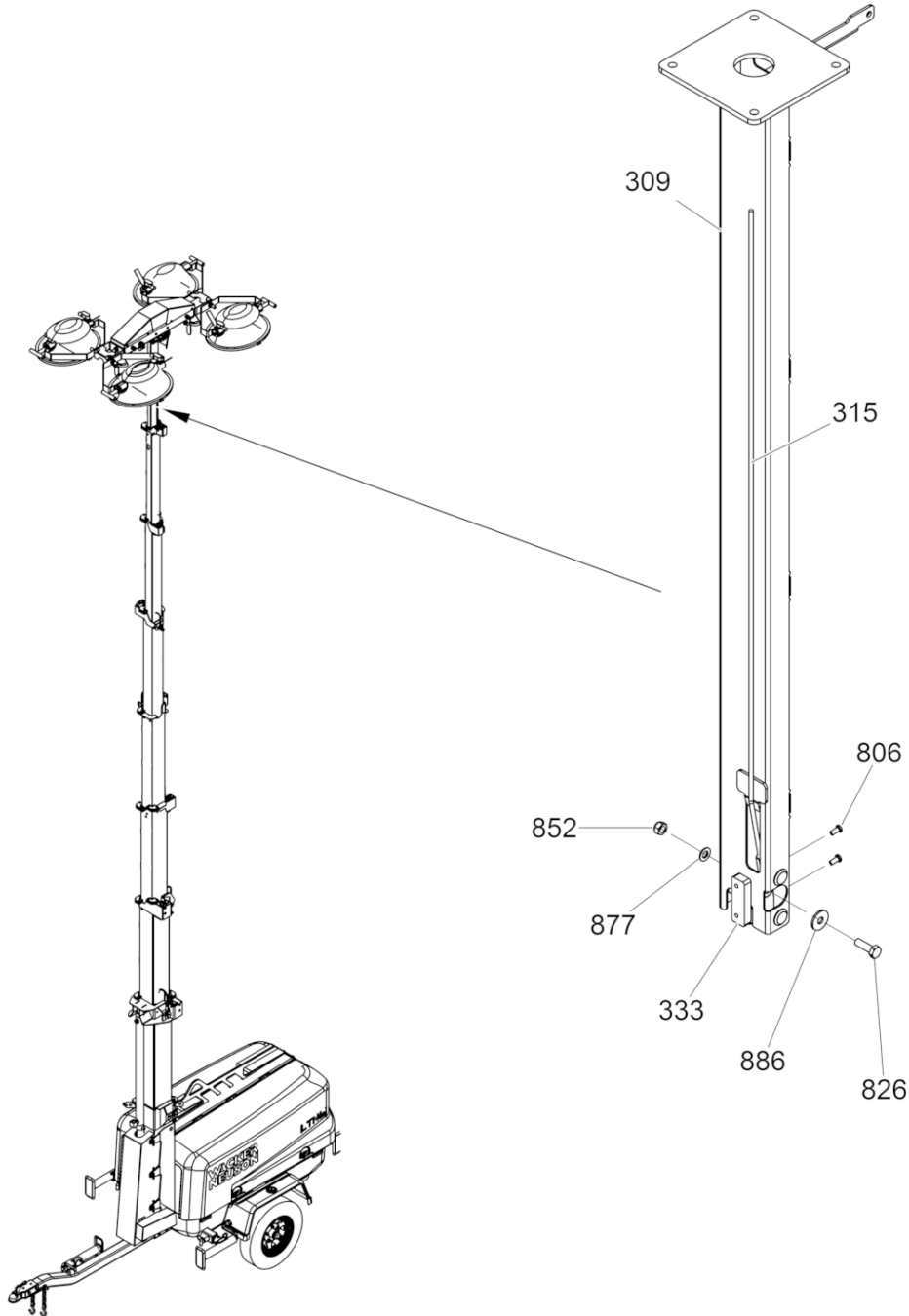

200_5200002720100058

Ref. Pos.	Part No. Artikel Nr.	Qty. St.	Description Beschreibung	Descripción Description	Measurement./Abm.	Norm
					Torque/Drehm.	Sealant Schmierstoff
309	5200009331	1	Tower Tube Turmröhre	Tubo de la torre Tube de la tour		
315	5200002131	1	Cable Kabel	Cable Câble	3/16in	
333	5200003227	1	Guide Führung	Guía Guide		
806	5000165226	2	Screw Schraube	Tornillo Vis	M5 x 10	
826	5000011457	1	Hexagonal head cap screw Sechskantschraube	Tornillo hexagonal Vis à tête hexagonale	M8 x 25 24Nm/18ft.lbs	DIN933
852	5000010367	1	Hexagon nut Sechskantmutter	Tuerca hexagonal Écrou hexagonal	M8	DIN985
877	5000010622	1	Flat washer Scheibe	Arandela Rondelle		
886	5000010374	1	Flat washer Scheibe	Arandela Rondelle		

Driver cpl.
Ballast kpl.

LTN6LE-V

Balastro compl.
Matériau de ballast compl.

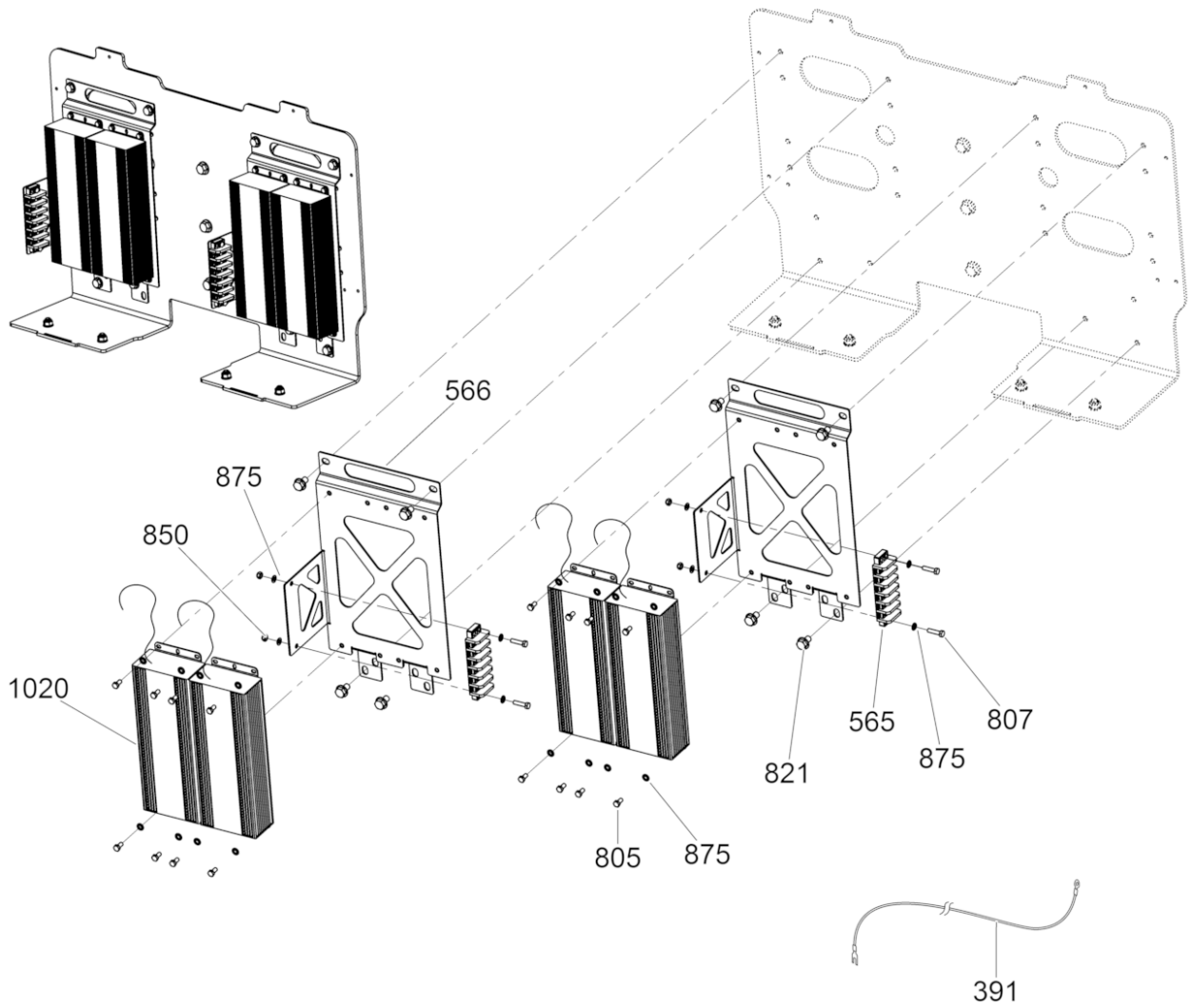

200_5200019140100005

Ref. Pos.	Part No. Artikel Nr.	Qty. St.	Description Beschreibung	Descripción Description	Measurem./Abm.	Norm
					Torque/Drehm.	Sealant Schmierstoff
391	5200018845	2	Wire-ground Erdungsdraht	Alambre a tierra Fil de masse		
565	5000176460	2	Terminal block Anschlussblock	Bloque terminal Borne serre-fils	6	
566	5200018778	2	Bracket Konsole	Soporte Support		
570	5000176163	12	Terminal Anschlußklemme	Terminal de conexión Borne d'attache		
805	5000011478	16	Hexagonal head cap screw Sechskantschraube	Tornillo hexagonal Vis à tête hexagonale	M5 x 10	DIN933
807	5000011475	4	Hexagonal head cap screw Sechskantschraube	Tornillo hexagonal Vis à tête hexagonale	M5 x 20 6Nm/4ft.lbs	DIN933
821	5000157021	20	Hexagonal flange head screw Sechskantflanschsraube	Tornillo hexagonal de brida Vis hexagonale de bride	M8 x 14 25Nm/18ft.lbs	
850	5000010369	4	Hexagon nut Sechskantmutter	Tuerca hexagonal Écrou hexagonal		
875	5000010625	32	Washer Scheibe	Arandela Rondelle		
886	5000010374	2	Flat washer Scheibe	Arandela Rondelle		
1020	5200022352	4	Driver Treiber	Guía Entraîneur		

Ref. Pos.	Part No. Artikel Nr.	Qty. St.	Description Beschreibung	Descripción Description	Measurement./Abm.	Norm
					Torque/Drehm.	Sealant Schmierstoff
421	5000175322	1	Control box Schaltkasten	Caja de control Boîtier des commandes		
516	5200012192	1	Timer module Zeitgeber	Temporizador Temporisateur		
529	5200012193	1	Resistor Widerstand	Resistencia Dispositif de resistance		
541	5000153758	1	Battery Nasse Batterie	Batería húmeda Batterie à l'eau	4in	
542	5000176457	1	Negative battery cable Minusbatterie kabel	Cable negativo de batería Câble négatif de batterie	26in	
543	5000176456	1	Positive battery cable Plusbatterie kabel	Cable positivo de batería Câble positif de batterie	40in	
546	5000176345	1	Battery bracket Batteriestütze	Soporte de batería Support de batterie		
547	5000154319	2	L-Bolt L-Bolzen	Perno forma L Boulon L	1/2-20 x 1-1/2in	
564	5000176461	1	Terminal block Anschlussblock	Bloque terminal Borne serre-fils	10	
776	5000173813	2	Cable tie Kabelbinder	Atadura de cable Serre-câble		
807	5000011475	2	Hexagonal head cap screw Sechskantschraube	Tornillo hexagonal Vis à tête hexagonale	M5 x 20 6Nm/4ft.lbs	DIN933
815	5000011368	1	Hexagonal head cap screw Sechskantschraube	Tornillo hexagonal Vis à tête hexagonale	M6 x 35 10Nm/7ft.lbs	DIN931
816	5000177093	8	Hexagonal flange head screw Sechskantflanschschrabe	Tornillo hexagonal de brida Vis hexagonale de bride	M6 x 16	
821	5000157021	2	Hexagonal flange head screw Sechskantflanschschrabe	Tornillo hexagonal de brida Vis hexagonale de bride	M8 x 14 25Nm/18ft.lbs	
850	5000010369	2	Hexagon nut Sechskantmutter	Tuerca hexagonal Écrou hexagonal		
851	5000010368	1	Hexagon nut Sechskantmutter	Tuerca hexagonal Écrou hexagonal	M6	DIN985
866	5000088190	8	Clip nut Klemmutter	Sujetador Agrafe	M6	
875	5000010625	2	Washer Scheibe	Arandela Rondelle		
1001	5000163117	1	Capacitor-25MFD Kondensator	Condensador Condensateur	25MFD	

Control Panel - AUS. RCBO
Schalttafel - AUS. RCBO
Tablero de Mando - AUS. RCBO
Tableau de Commande - AUS. RCBO

LTN6LE-V

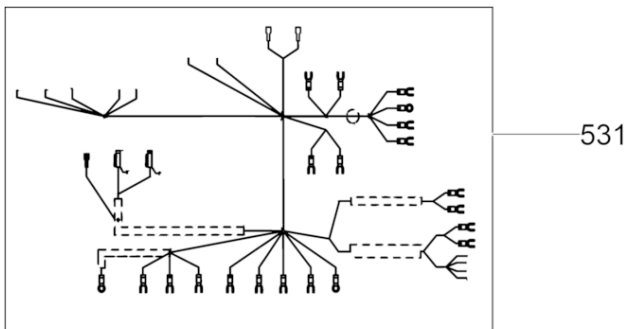
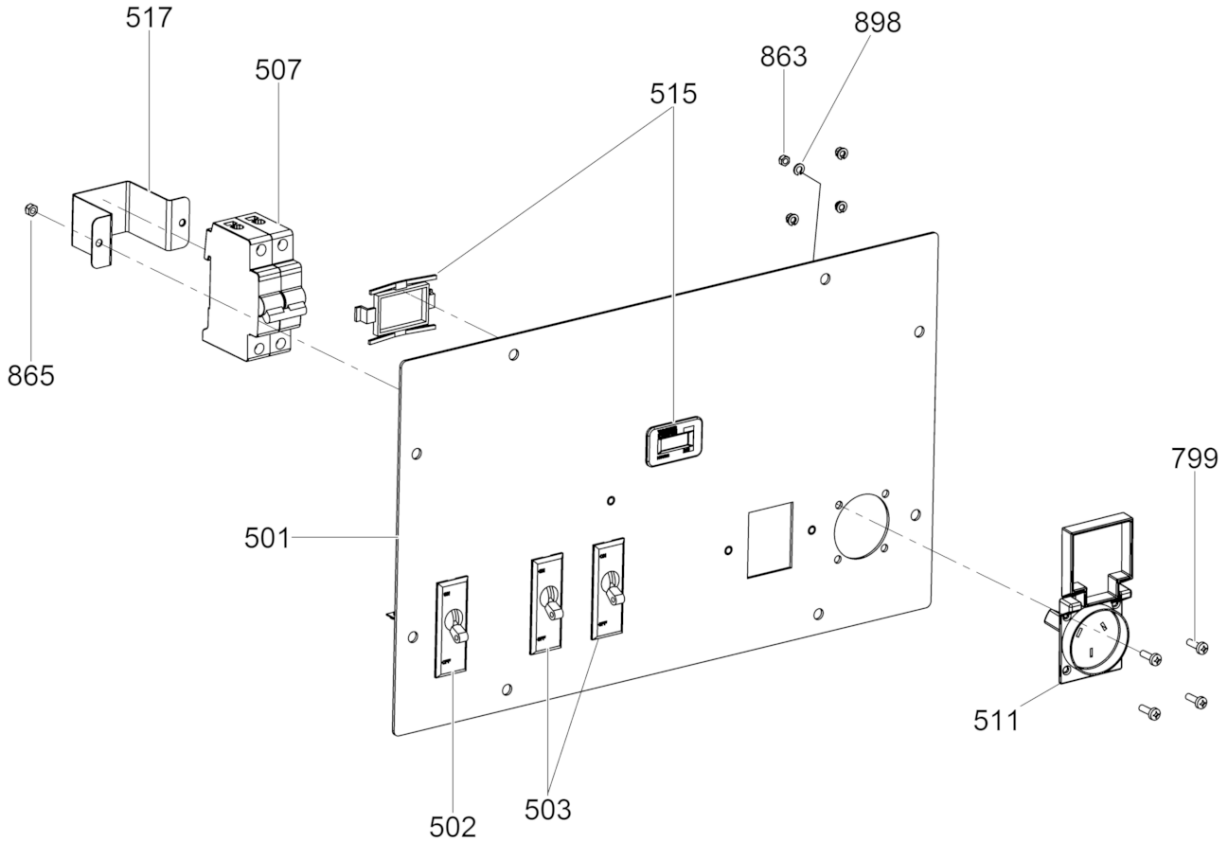

200_5200021870002001

Ref. Pos.	Part No. Artikel Nr.	Qty. St.	Description Beschreibung	Descripción Description	Measurement/Abm.	Norm
					Torque/Drehm.	Sealant Schmierstoff
501	5200014953	1	Control panel Schalttafel	Tablero de mando Tableau de commande		
502	5000172336	1	Circuit breaker w/trip relay Unterbrecher/Schnellauslöserelais	Interruptor de circuito/relaidisparador Coupe-circuit/relais à action	25A	
503	5000172337	2	Breaker Unterbrecher	Interruptor Disjoncteur	30A	
507	5200021854	1	Breaker, RCBO Unterbrecher	Interruptor Disjoncteur	230V, 30MA, 10A, 2P	
511	5200021856	1	Receptacle Steckdose	Tomacorriente Prise de courant	230V, 50Hz	
515	5000117280	1	Hour meter Stundenzähler	Horometro Compteur horaire		
517	5200014955	1	Bracket Konsole	Soporte Support		
531	5200014956	1	Wiring harness Kabelbaum	Conjunto de cables Harnais de câbles électriques		
799	5100019401	4	Screw Schraube	Tornillo Vis	M3X20	
863	5000086710	4	Lock nut Sicherungsmutter	Contratuerca Contre-écrou	M3	DIN985
865	5000110002	2	Lock nut Sicherungsmutter	Contratuerca Contre-écrou	M3,5	
898	5100019402	4	Washer Scheibe	Arandela Rondelle	M3	

Fuel Tank/Lifteye
Kraftstofftank/Hebeöse
Tanque de Combustible/Punto deizaje
Réservoir de Carburant/Anneau

LTN6LE-V

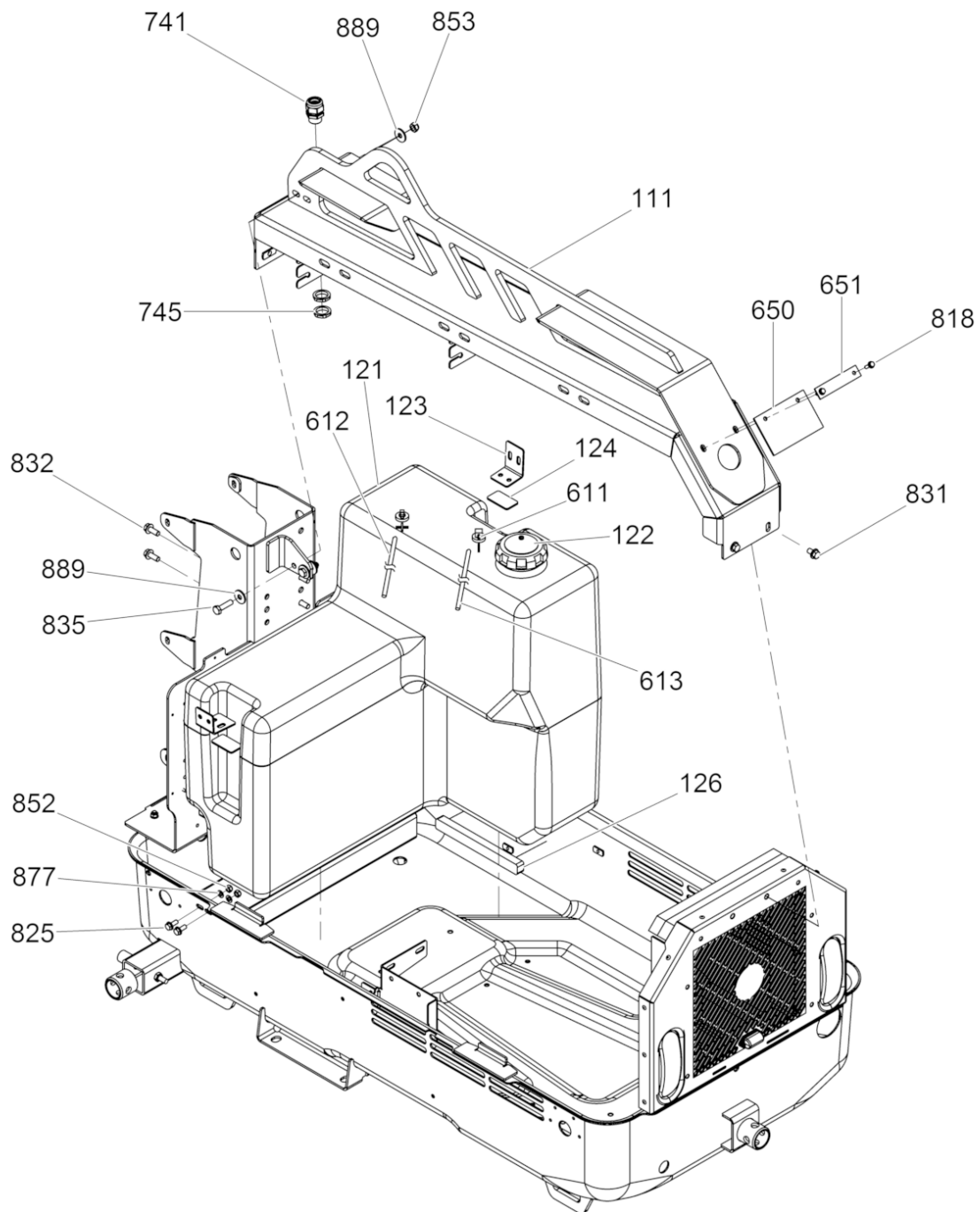

200_5200002720100012

Ref. Pos.	Part No. Artikel Nr.	Qty. St.	Description Beschreibung	Descripción Description	Measurement./Abm.	Norm
					Torque/Drehm.	Sealant Schmierstoff
111	5200002162	1	Bracket Konsole	Soporte Support		
121	5000165120	1	Fuel tank Kraftstofftank	Depósito de combustible Réservoir de carburant		
122	5200013529	1	Cap Kappe	Tapa Capuchon		
123	5000165121	2	Bracket Konsole	Soporte Support		
124	5000177081	2	Pad Unterlage	Cojín Coussin		
126	5000177423	1	Pad Unterlage	Cojín Coussin		
611	5000177644	1	Fuel hose Kraftstoffleitung	Manguera de combustible Tuyau de carburant	1/4in OD x 960	
612	5000182411	1	Return line hose Rückleitungsschlauch	Manguera de retorno Tuyau de retour	3/16in x 960mm	
613	5000028707	4	Clamp Schelle	Abrazadera Agrafe	0,21-0,63	
650	5000172926	1	Cover Deckel	Tapa Couvercle		
651	5000171601	1	Plate Platte	Placa Plaque		
741	5000165222	1	Cord grip Zugentlastung	Alivio de esfuerzos Effort à la décharge	3/4in NPT	
745	5000176419	2	Lock nut Sicherungsmutter	Contratuerca Contre-écrou	3/4in	
818	5000029116	2	Hexagonal head cap screw Sechskantschraube	Tornillo hexagonal Boulon à tête hexagonale	M6 x 1 x 20 10Nm/7ft.lbs	
825	5000028404	4	Screw Schraube	Tornillo Vis	M8 x 20 25Nm/18ft.lbs	
831	5000164061	2	Hexagonal head cap screw Sechskantschraube	Tornillo hexagonal Boulon à tête hexagonale	M10 x 16	
832	5000116164	4	Screw Schraube	Tornillo Vis	M10 x 25	
835	5000011318	2	Hexagonal head cap screw Sechskantschraube	Tornillo hexagonal Vis à tête hexagonale	M10 x 40 49Nm/36ft.lbs	DIN931
852	5000173911	4	Lock nut Sicherungsmutter	Contratuerca Contre-écrou	M8	
853	5000010365	2	Lock nut Sicherungsmutter	Contratuerca Contre-écrou	M10	DIN980
877	5000010622	4	Flat washer Scheibe	Arandela Rondelle		
889	5000010375	4	Flat washer Scheibe	Arandela Rondelle	B10,5	DIN9021

Switch/Hydraulic pump
Schalter/Hydraulikpumpe
Interruptor/Bomba hidráulica
Interrupteur/Pompe hydraulique

LTN6LE-V

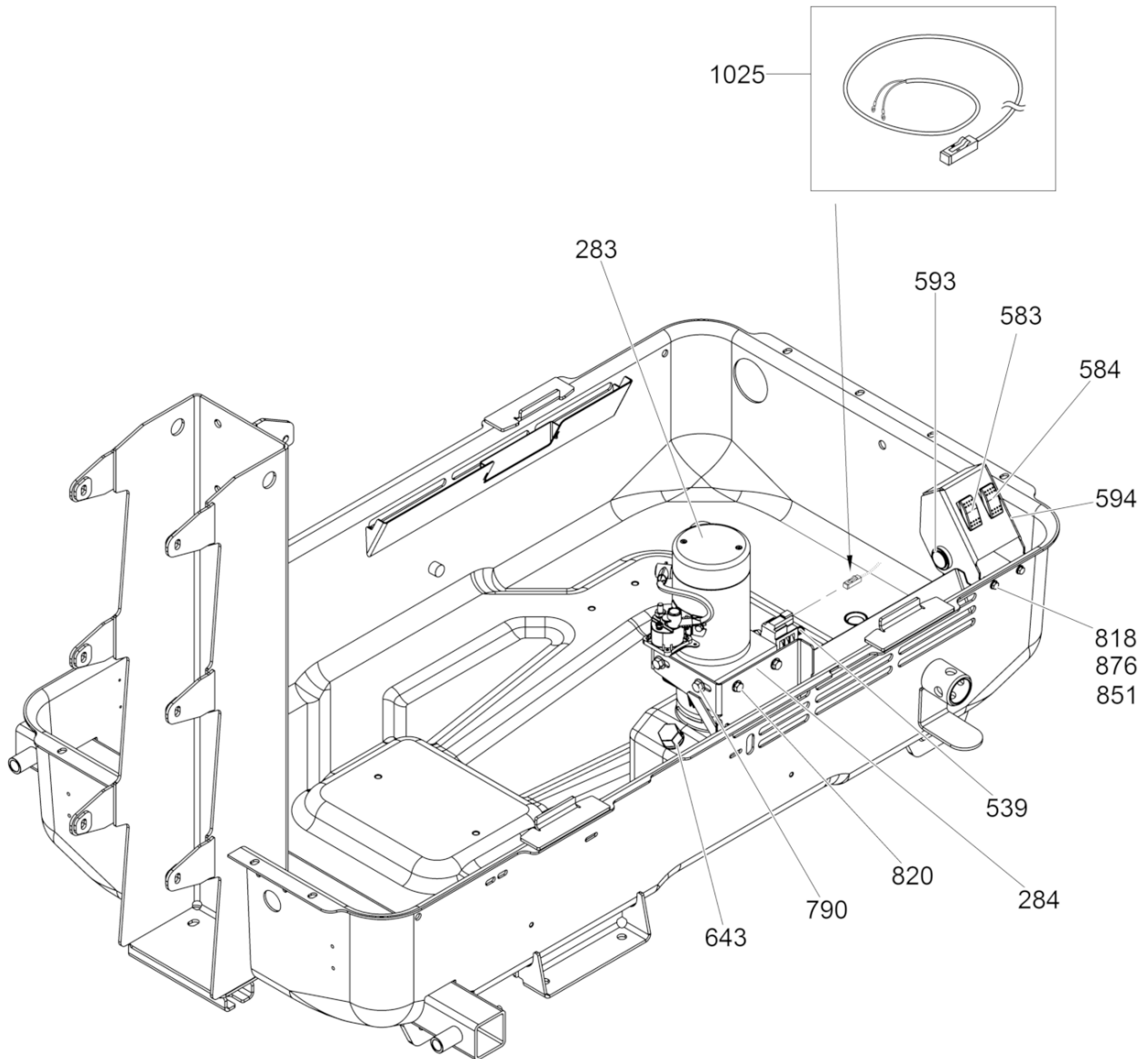

200_5200002720100003

Ref. Pos.	Part No. Artikel Nr.	Qty. St.	Description Beschreibung	Descripción Description	Measurement./Abm.	Norm
					Torque/Drehm.	Sealant Schmierstoff
283	5200002264	1	Pump Pumpe	Bomba Pompe		
284	5200005795	1	Bracket Konsole	Soporte Support		
539	5000083175	1	Ring terminal Geschlossen. Kabelschuh	Terminal de anillo Cosse de câble à plage fermée		
583	5200002181	1	Switch Schalter	Interruptor Interrupteur		
584	5000165482	1	Cover Deckel	Tapa Couvercle		
593	5200002190	1	Alarm Alarm	Alarma Avertisseur		
594	5200002194	1	Switch box Schaltkasten	Caja del interruptor Coffret électrique		
790	5000178129	2	Screw Schraube	Tornillo Vis	3/8	
818	5000029116	2	Hexagonal head cap screw Sechskantschraube	Tornillo hexagonal Boulon à tête hexagonale	M6 x 1 x 20 10Nm/7ft.lbs	
820	5000111040	1	Screw Schraube	Tornillo Vis	M8 x 12 25Nm/18ft.lbs	
851	5000010367	2	Hexagon nut Sechskantmutter	Tuerca hexagonal Écrou hexagonal	M8	DIN985
876	5000010624	2	Flat washer Scheibe	Arandela Rondelle		
1025	5200019270	1	Wiring harness- Hydraulic pump solenoid Kabelbaum- Hydraulikpumpe	Conjunto de cables- Bomba hidráulica Harnais de câbles électriques-		

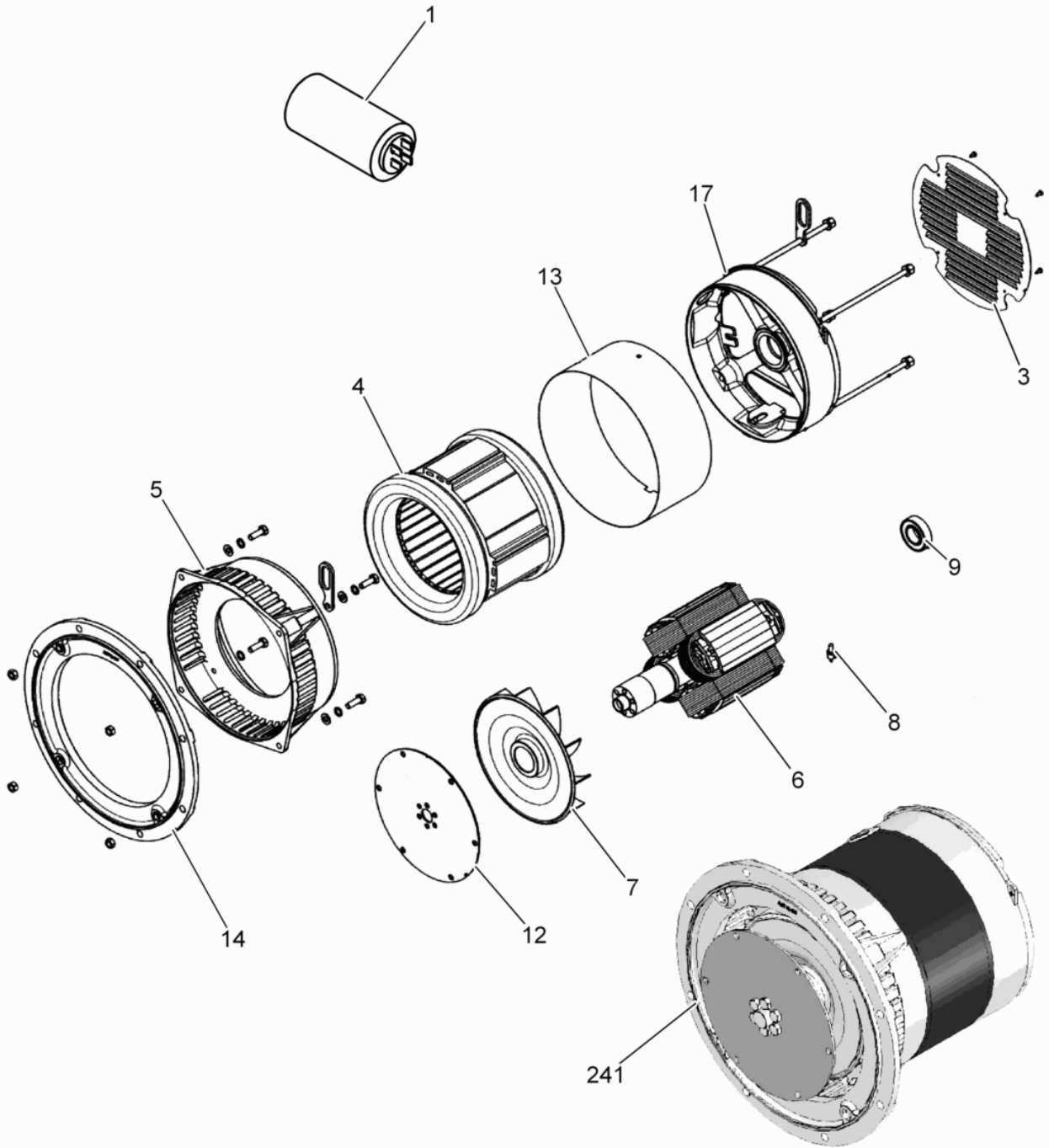

wc_ex0620117100_18

Ref. Pos.	Part No. Artikel Nr.	Qty. St.	Description Beschreibung	Descripción Description	Measurement./Abm.	Norm
					Torque/Drehm.	Sealant Schmierstoff
1	5000163150	1	Capacitor, 35mF Kondensator	Condensador Condensateur	50Hz, 35mF	
3	5000163103	1	Seal Dichtung	Empaque Joint		
4	5000163148	1	Stator Stator	Estator Stator	50Hz	
5	5000163105	1	Bracket Konsole	Soporte Support		
6	5000163149	1	Rotor cpl. Rotor kpl.	Rotor compl. Rotor compl.	50Hz	
7	5200018622	1	Fan (Plastic) Gebläserad (Kunststoff)	Ventilador (plástico) Ventilateur (plastique)		
8	5000163108	1	Diode Diode	Diodo Rectificateur		
9	5000163109	1	Bearing Lager	Rodamiento Roulement		
12	5000163111	1	Flex plate Flexplatte	Placa flexible Plaque flexible		
13	5000163151	1	Guard ring Schutzring	Anillo de protección Anneau de garde	50Hz	
14	5000163113	1	Mounting flange Flansch	Brida Bourrelet d'assemblage		
17	5000163114	1	Bracket Konsole	Soporte Support		
241	5000165295	1	Generator cpl. Generator kpl.	Conjunto generador Générateur compl.	50Hz	

Generator/Engine Support
Generator/Motorbefestigung
Generador/Montaje del Motor
Générateur/Montage du Moteur

LTN6LE-V

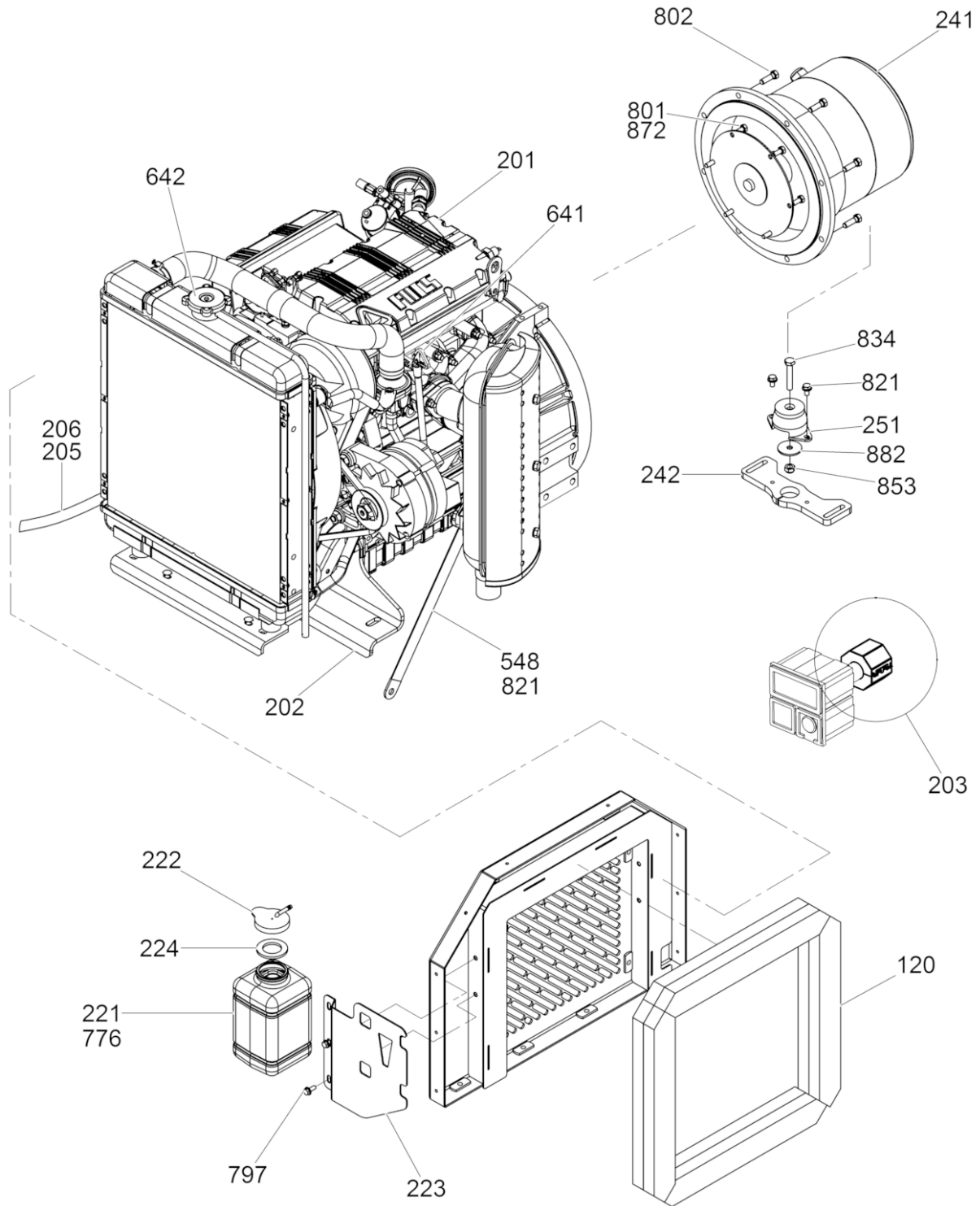

200_5200002718100006

Ref. Pos.	Part No. Artikel Nr.	Qty. St.	Description Beschreibung	Descripción Description	Measurement./Abm.	Norm
					Torque/Drehm.	Sealant Schmierstoff
120	5200002031	4	Seal Dichtung	Empaque Joint		
201	5000158995	1	Lombardini engine Lombardini-Motor	Motor Lombardini Moteur Lombardini		
202	5000179168	1	Engine bracket Zylinderkonsole	Soporte del motor Support de culasse		
203	5000178142	1	Clamp Schelle	Abrazadera Agrafe		
205	5000119962	1	Fitting Verschraubung	Unión Raccord	No.8	
206	5000176428	1	Oil drain hose Ölabflussschlauch	Manguera de drenaje de aceite Flexible de vidange d'huile		
221	5000165143	1	Overflow bottle Überlaufflasche	Botella de rebose Bouteille de trop-plein		
222	5000165144	1	Cap Kappe	Tapa Capuchon		
223	5200008153	1	Bracket Konsole	Soporte Support		
224	5000183432	1	Gasket Dichtung	Junta Joint		
241	5000165295	1	Generator cpl. Generator kpl.	Conjunto generador Générateur compl.	50Hz	
242	5200002441	1	Plate Platte	Placa Plaque		
251	5000164631	1	Shockmount Puffer	Amortiguador Silentbloc		
548	5000152979	1	Strap Band	Correa Ruban	15in	
776	5000173813	2	Cable tie Kabelbinder	Atadura de cable Serre-câble		
797	5000028949	2	Screw Schraube	Tornillo Vis	M6 x 16 10Nm/7ft.lbs	
801	5000176100	6	Screw Schraube	Tornillo Vis	5/16-18 x 3/4in	
802	5000025554	8	Screw Schraube	Tornillo Vis	3/8-16 x 1in 31Nm/23ft.lbs	
821	5000157021	3	Hexagonal flange head screw Sechskantflanschschrabe	Tornillo hexagonal de brida Vis hexagonale de bride	M8 x 14 25Nm/18ft.lbs	
834	5000011322	1	Hexagonal head cap screw Sechskantschraube	Tornillo hexagonal Vis à tête hexagonale	M10 x 60 49Nm/36ft.lbs	DIN931
853	5000010365	1	Lock nut Sicherungsmutter	Contratuerca Contre-écrou	M10	DIN980
872	5000177342	6	Flat washer Scheibe	Arandela elástica Rondelle de ressort	M8	
882	5000162258	1	Flat washer Scheibe	Arandela elástica Rondelle de ressort	0,40 x 1.75 x 0,12	

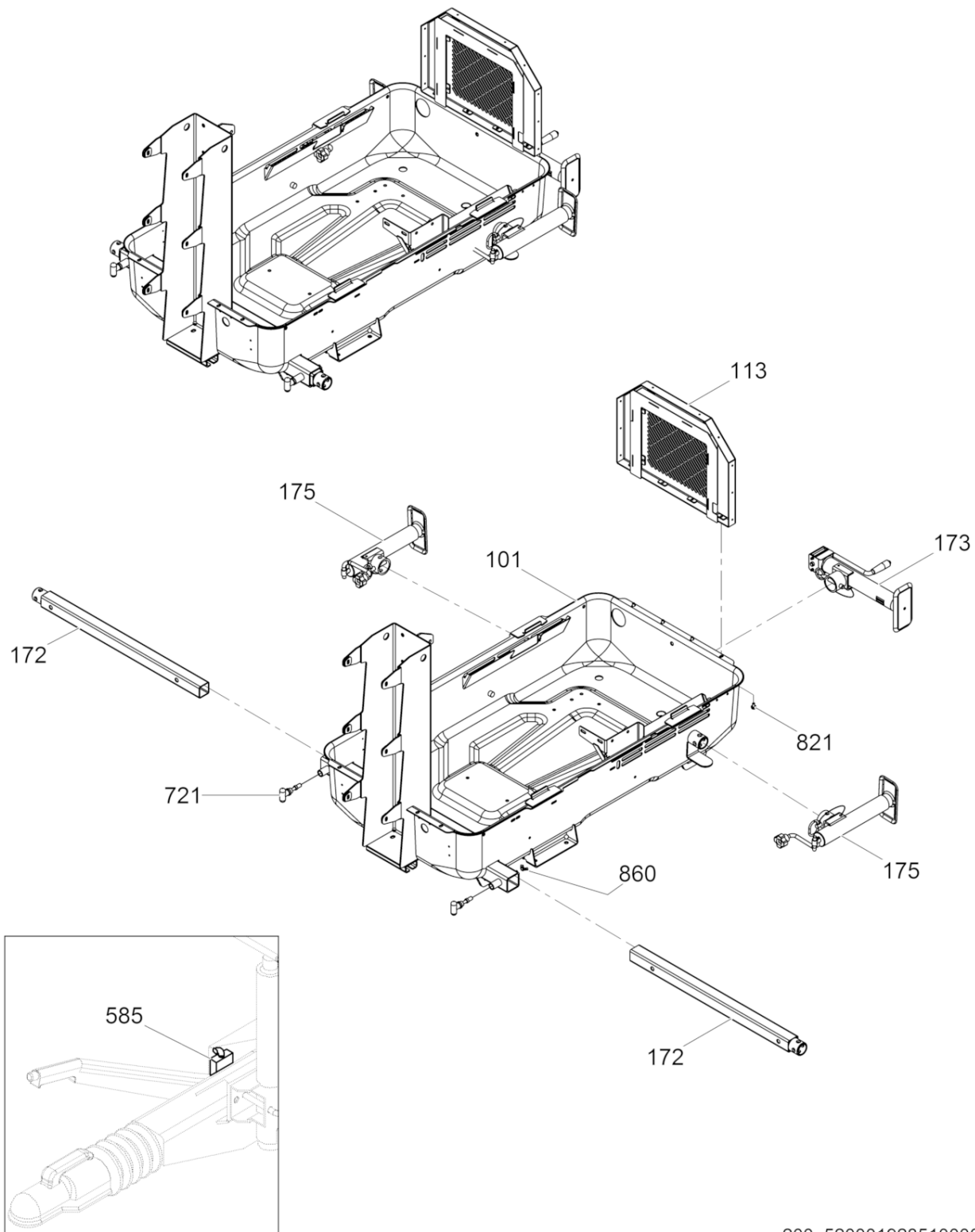

200_520001928510007

Ref. Pos.	Part No. Artikel Nr.	Qty. St.	Description Beschreibung	Descripción Description	Measurement/Abm.	Norm
					Torque/Drehm.	Sealant Schmierstoff
101	5200002213	1	Skid Palette	Paleta Palette		
113	5200002014	1	Panel Panel	Panel Tableau		
172	5000165127	2	Tube Rohr	Tubo Tube		
173	5000168507	1	Swivel jack Drehwagenheber	Gato giratorio Cric rotatif		
175	5000174684	2	Swivel jack Drehwagenheber	Gato giratorio Cric rotatif	2000lb, 10in OD	
585	5200002183	1	Switch Schalter	Interruptor Interrupteur		
721	5000165130	2	Pin, detent Vorsteckstift	Pasador Axe, cran d'arrêt		
821	5000157021	4	Hexagonal flange head screw Sechskantflanschschaube	Tornillo hexagonal de brida Vis hexagonale de bride	M8 x 14 25Nm/18ft.lbs	
860	5000010897	1	Wing nut Flügelmutter	Tuerca de mariposa Écrou à oreilles	M10	DIN315

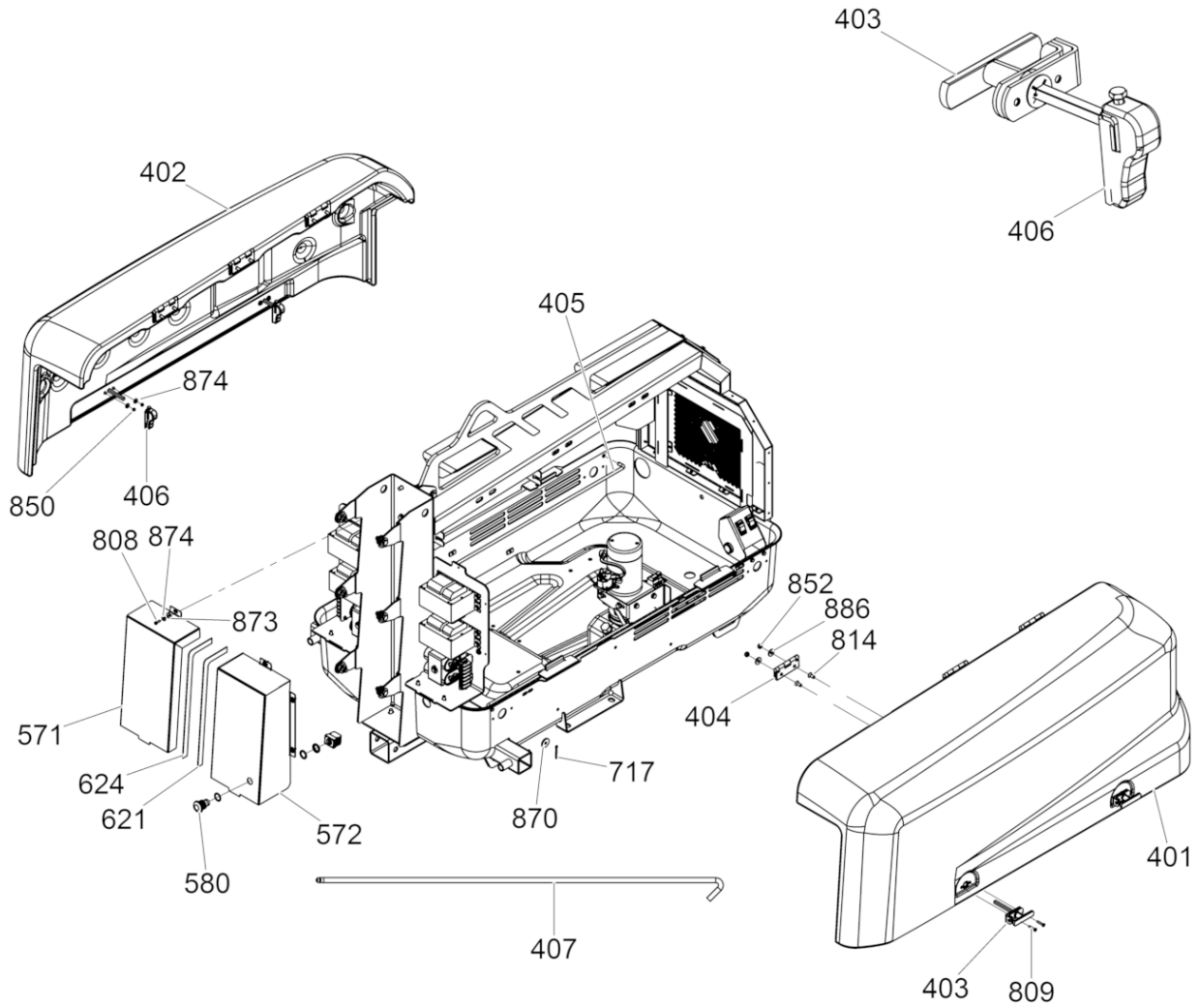

200_5200019285100008

Ref. Pos.	Part No. Artikel Nr.	Qty. St.	Description Beschreibung	Descripción Description	Measurement/Abm.	Norm
					Torque/Drehm.	Sealant Schmierstoff
401	5100026307	1	Door w/ labels (left, gray) Tür mit Aufkleber (links, grau)	Puerta con Calcomanias (izquierda, gris) Portière avec Autocollants (ga)		
402	5100026306	1	Door w/ labels (right, gray) Tür mit Aufkleber (rechts, grau)	Puerta con Calcomanias (derecha, gris) Portière avec Autocollants (dr)		
403	5000174964	4	Handle Handgriff	Manija Poignée		
404	5000165197	6	Hinge Scharnier	Bisagra Charnière		
405	5000177624	1	Rod Stange	Varilla Tringle		
406	5000174965	4	Cam Nocken	Leva Came		
407	5200005280	1	Rod Stange	Varilla Tringle		
571	5000165205	1	Cover Deckel	Tapa Couvercle		
572	5000172860	1	Cover Deckel	Tapa Couvercle		
580	5000165439	1	Push button switch Druckknopfschalter	Interruptor de botón Interrupteur à poussoir		
621	5000176104	1	Gasket Dichtung	Junta Joint		
624	5000177663	1	Gasket Dichtung	Junta Joint		
717	5000116751	2	Cotter pin Sicherungssplint	Clavija hendida Goupille fendue	1/8 x 1-1/2in	
808	5000011476	6	Hexagonal head cap screw Sechskantschraube	Tornillo hexagonal Vis à tête hexagonale	M5 x 16 6Nm/4ft.lbs	DIN933
809	5000176154	8	Flat head screw Senkschraube	Tornillo de cabeza perdida Vis à tête conique	M5 x 30	
814	5000021563	12	Countersunk screw Senkschraube	Tornillo avellanado Vis noyée	M8 x 20 25Nm/18ft.lbs	ISO10642
850	5000010369	8	Hexagon nut Sechskantmutter	Tuerca hexagonal Écrou hexagonal		
852	5000010367	12	Hexagon nut Sechskantmutter	Tuerca hexagonal Écrou hexagonal	M8	DIN985
870	5000177109	2	Washer Scheibe	Arandela Rondelle	7,90 x 31,80 x 3,81	
873	5000177343	6	Serrated lockwasher Zahnscheibe	Arandela estriada Rondelle à éventail	M5	
874	5000010372	14	Flat washer Scheibe	Arandela Rondelle	B5,3	DIN9021
886	5000010374	12	Flat washer Scheibe	Arandela Rondelle		

Option-Containment skid
Sonderzubehör-Sammelbecken
Opción-Recipiente colector
Option-Réservoir à liquides

LTN6LE-V

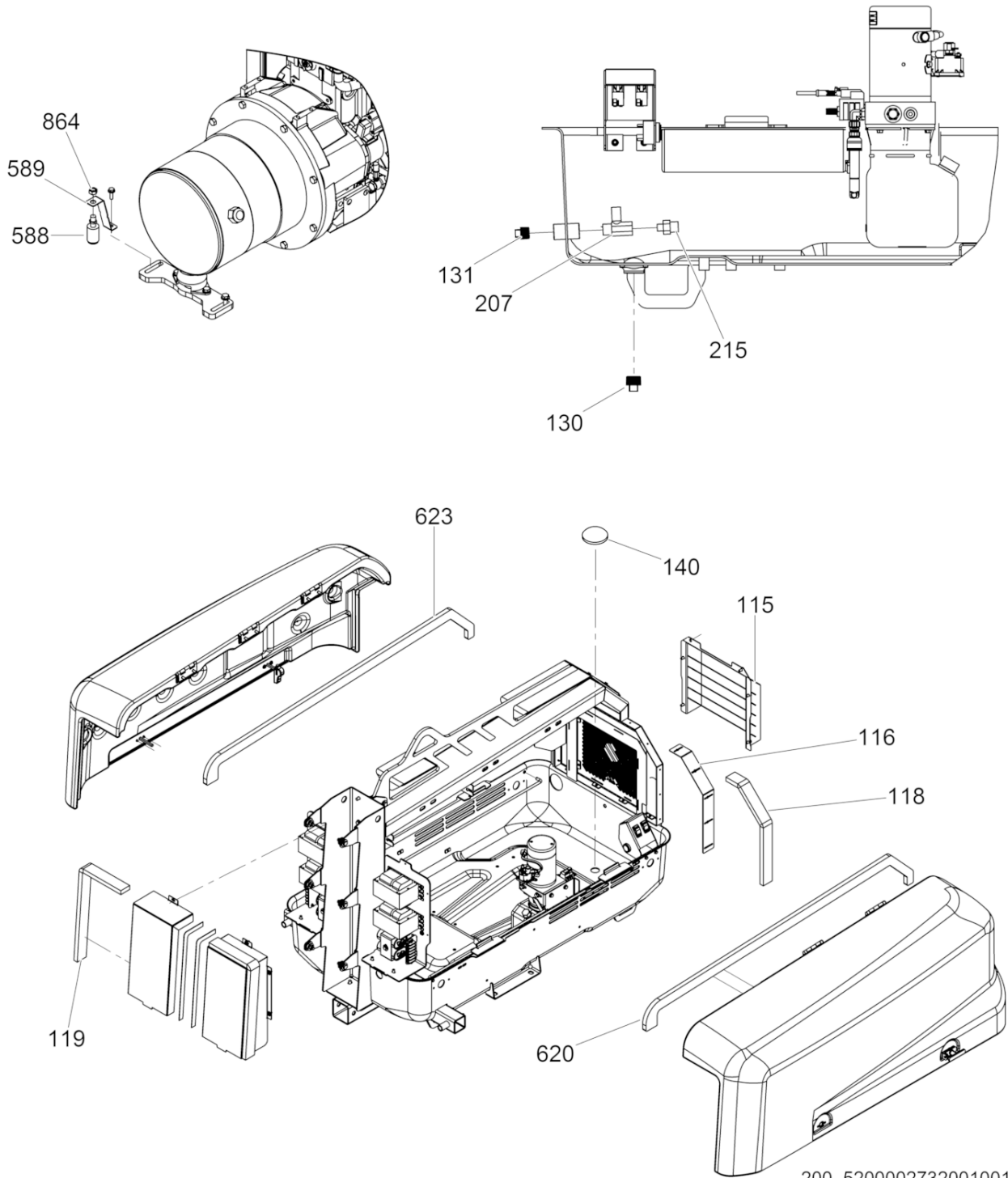

Ref. Pos.	Part No. Artikel Nr.	Qty. St.	Description Beschreibung	Descripción Description	Measurement./Abm.	Norm
					Torque/Drehm.	Sealant Schmierstoff
115	5200002009	1	Shroud Haube	Guardera Carénage		
116	5200002023	2	Bracket Konsole	Soporte Support		
118	5200002029	2	Seal Dichtung	Empaque Joint		
119	5200002028	2	Seal Dichtung	Empaque Joint		
130	5000168154	1	Plug Stopfen	Tapón Bouchon	3/4in NPT	
131	5200004588	1	Plug Stopfen	Tapón Bouchon		
140	5200002482	6	Plug Stopfen	Tapón Bouchon		
207	5000154305	1	Ball valve Kugelhahn	Válvula de bola Robinet à boisseau sphérique		
215	5000180857	1	Fitting Verschraubung	Unión Raccord	1/2 JIC x 1/2in NPT	
588	5200002184	1	Switch Schalter	Interruptor Interrupteur		
589	5200002193	1	Bracket Konsole	Soporte Support		
620	5000176397	1	Gasket Dichtung	Junta Joint		
623	5000177664	1	Gasket Dichtung	Junta Joint		

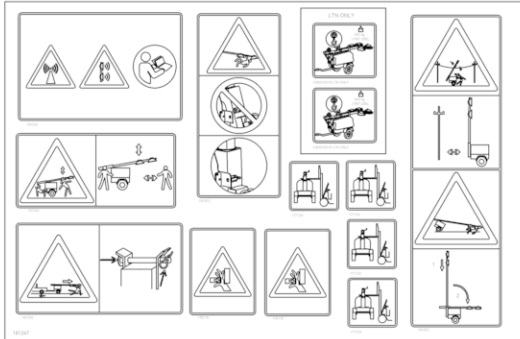

3

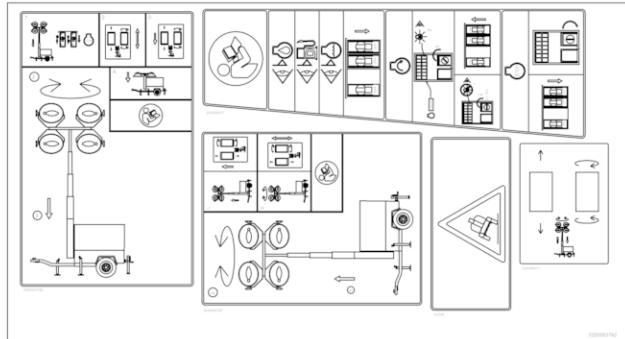

4

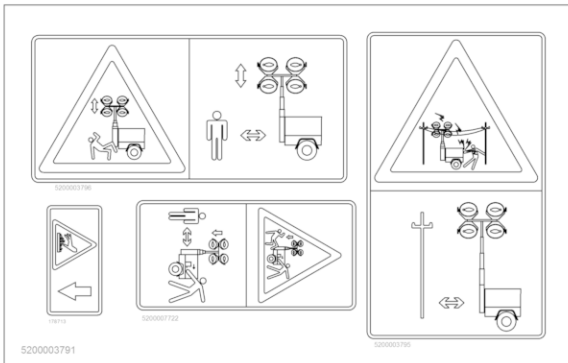

5



6



1

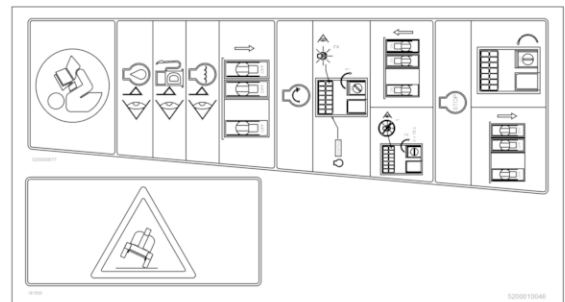

8

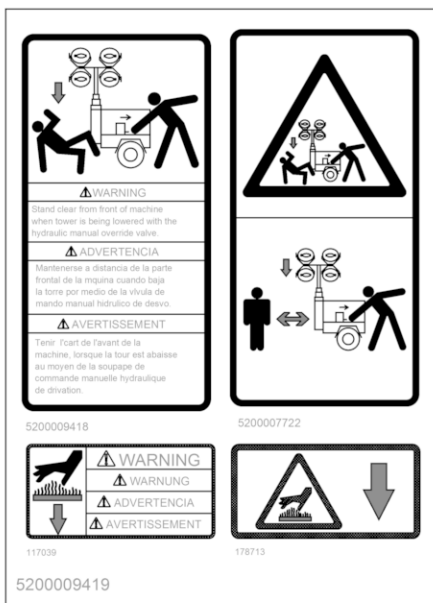

7

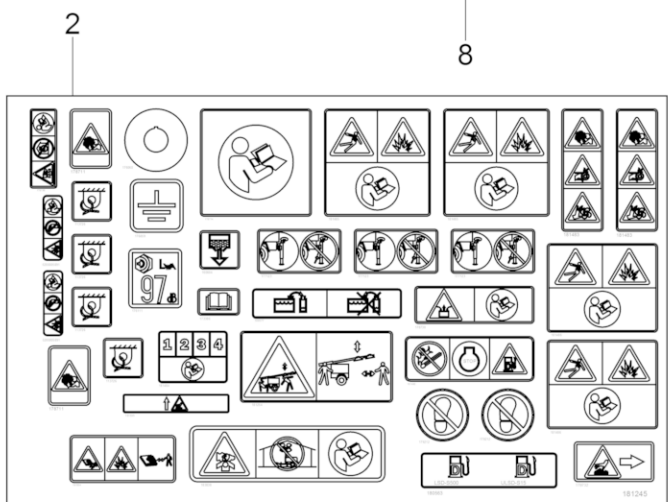

2

200_5200002718100060

Ref. Pos.	Part No. Artikel Nr.	Qty. St.	Description Beschreibung	Descripción Description	Measurement./Abm.	Norm
					Torque/Drehm.	Sealant Schmierstoff
1	5000222086	1	Label Symbol Aufkleber Symbol	Calcomania Símbolo Autocollant Symbole		
2	5000181245	1	Label sheet Aufkleberblatt	Hoja de calcomanias Feuille d'autocollants		
3	5000181247	1	Label sheet Aufkleberblatt	Hoja de calcomanias Feuille d'autocollants		
4	5200003792	1	Label sheet-EU Aufkleberblatt-EU	Hoja de calcomanias-EU Feuille d'autocollants-EU		
5	5200003791	1	Label sheet-EU Aufkleberblatt-EU	Hoja de calcomanias-EU Feuille d'autocollants-EU		
6	5200012402	1	Label Aufkleber	Calcomania Autocollant		
7	5200009419	1	Label sheet Aufkleberblatt	Hoja de calcomanias Feuille d'autocollants		
8	5200010046	1	Label sheet-EU Aufkleberblatt-EU	Hoja de calcomanias-EU Feuille d'autocollants-EU		



411



410

200_5000620117144001

Ref. Pos.	Part No. Artikel Nr.	Qty. St.	Description Beschreibung	Descripción Description	Measurem./Abm.	Norm
					Torque/Drehm.	Sealant Schmierstoff
410	5000176477	2	Label Aufkleber	Calcomania Autocollant		
411	5000176478	2	Label Aufkleber	Calcomania Autocollant		



**WACKER
NEUSON**

**Engine-Kohler
Kohler-Motor
Motor Kohler
Moteur Kohler**

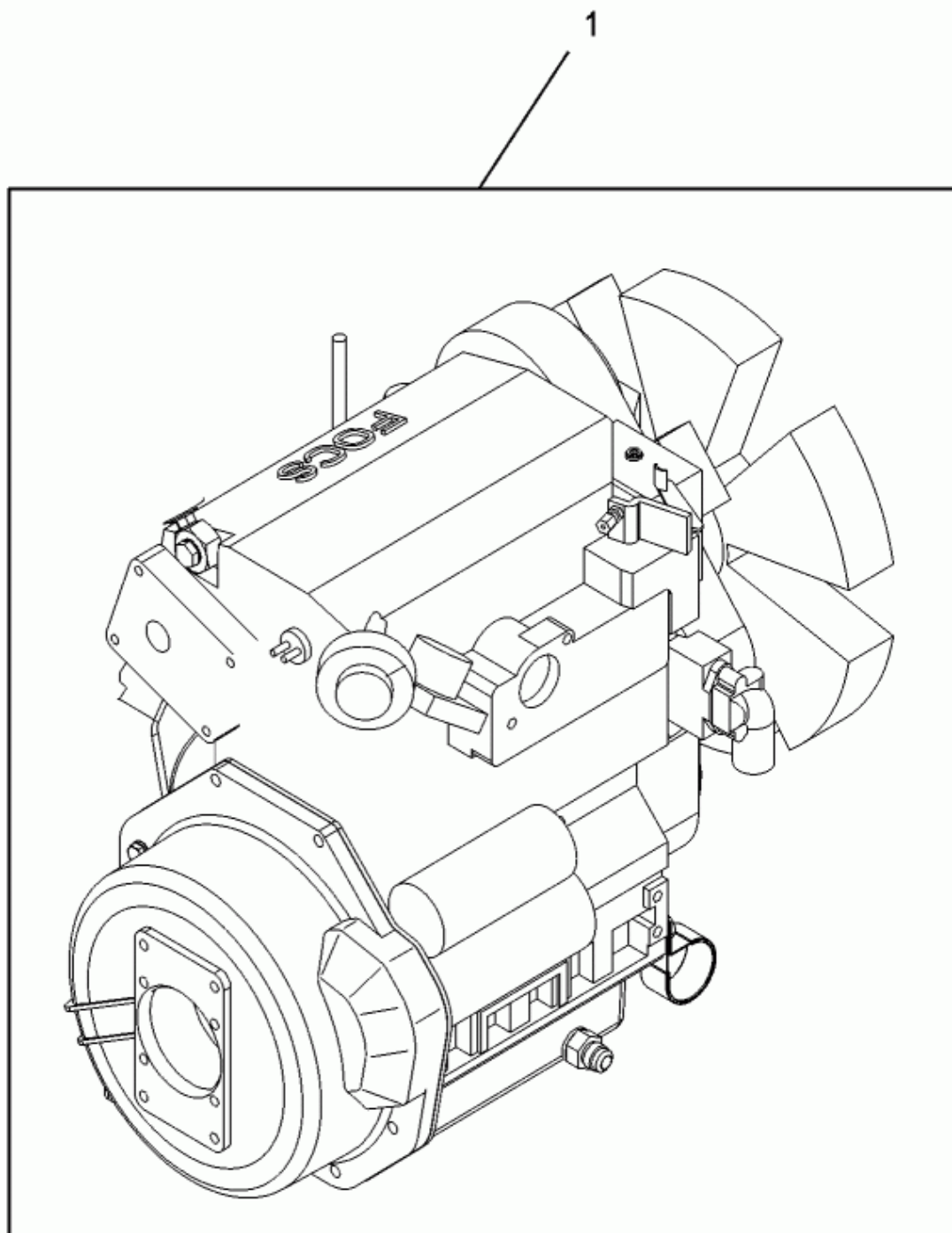

wc_ex0158995000_01

Ref. Pos.	Part No. Artikel Nr.	Qty. St.	Description Beschreibung	Descripción Description	Measurement./Abm.	Norm
					Torque/Drehm.	Sealant Schmierstoff
1	5000158995	1	Lombardini engine Lombardini-Motor	Motor Lombardini Moteur Lombardini		

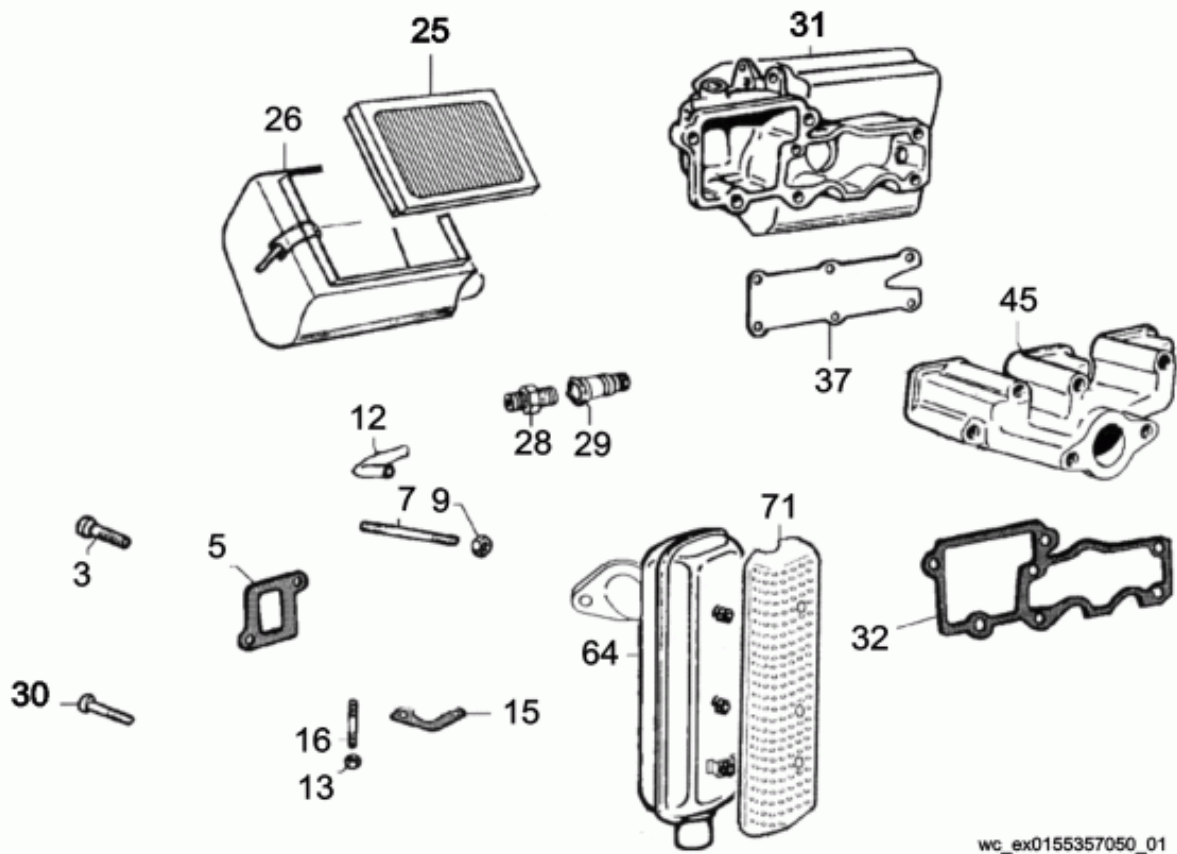

Ref. Pos.	Part No. Artikel Nr.	Qty. St.	Description Beschreibung	Descripción Description	Measurem./Abm.	Norm
					Torque/Drehm.	Sealant Schmierstoff
3	5000159476	3	Screw Schraube	Tornillo Vis		
5	5000159290	3	Gasket Dichtung	Junta de estanqueidad Garniture		
7	5000082267	6	Stud Gewindebolzen	Perno prisionero Boulon		
9	5000086331	6	Nut Mutter	Tuerca Écrou		
12	5000160356	1	Pipe Rohr	Tubo Conduit		
13	5000086331	2	Nut Mutter	Tuerca Écrou		
15	5000159295	1	Gasket Dichtung	Junta de estanqueidad Garniture		
16	5000160228	2	Threaded bolt Gewindebolzen	Perno roscado Boulon fileté	M8x22	
25	5000155678	1	Air cleaner cartridge Luftfilterpatrone	Cartucho de filtro del aire Cartouche du filtre à air		
26	5000155679	1	Air cleaner cover Luftfilterdeckel	Tapa-filtro del aire Couvercle-filtre à air		
28	5000160229	1	Union pipe Abflussrohr	Tubo de salida Tube d'écoulement	M10 x 1	
29	5000155680	1	Clogging indicator Verstopfungsanzeiger	Indicador de obstrucción Indicateur de colmatage		
30	5000084170	6	Screw Schraube	Tornillo Vis		
31	5000155681	1	Air filter support manifold Luftfilterkonsoleverteiler	Distribuidor de soporte de filtro del aire Tubulure du support du filtre		
32	5000160186	1	Intake manifold gasket Ansaugkrümmerdichtung	Junta-distribuidor de admisión Joint-collecteur d'admission		
37	5000082213	1	Panel Panel	Panel Tableau		
45	5000155682	1	Exhaust manifold Auspuffkrümmer	Distribuidor de escape Collecteur d'échappement		
64	5000155683	1	Exhaust muffler Auspufftopf	Silenciador de escape Silencieux		
71	5000155684	1	Muffler guard Auspuffschutz	Protector de silenciador Protecteur de silencieux		

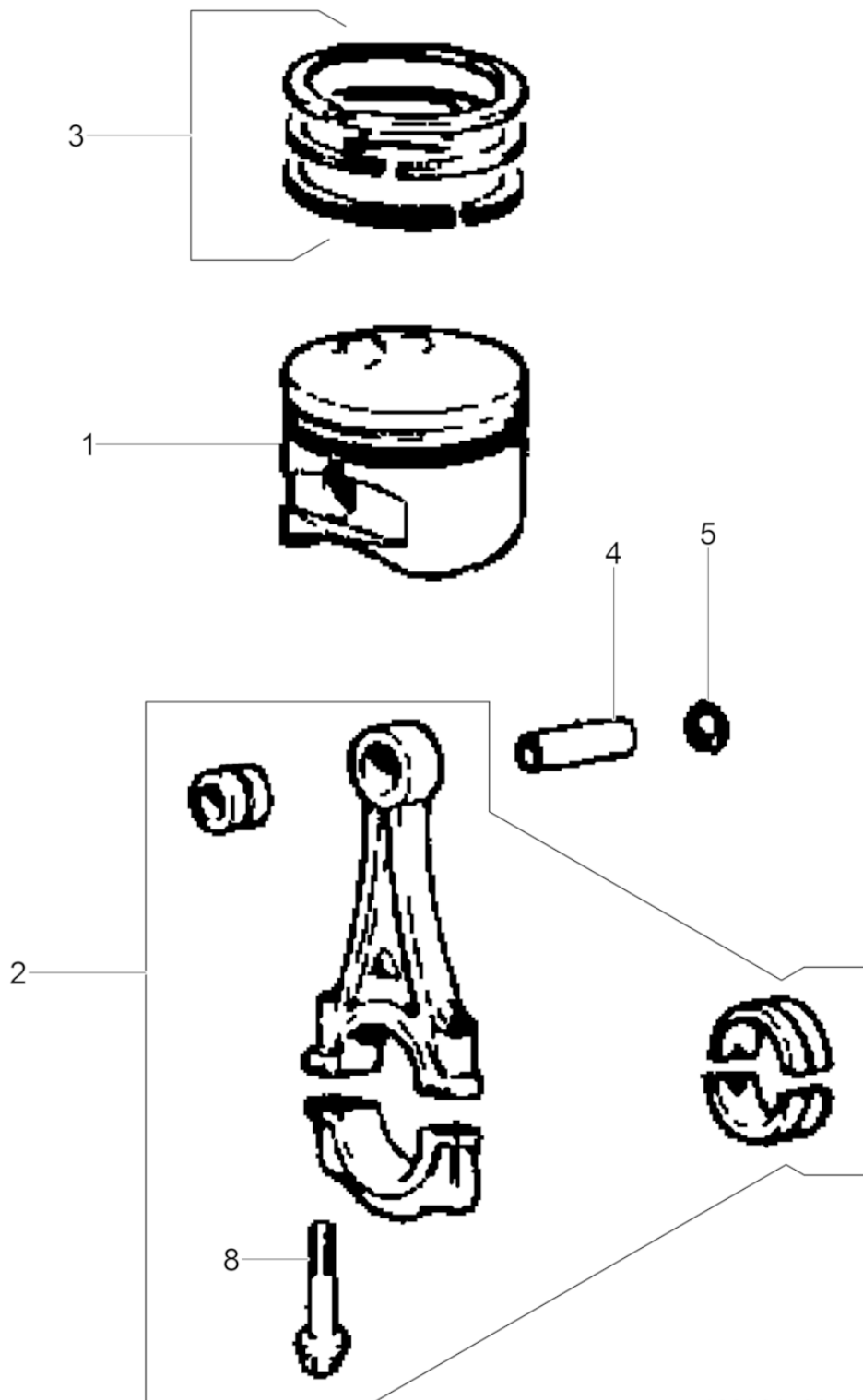

5100026789_01

Ref. Pos.	Part No. Artikel Nr.	Qty. St.	Description Beschreibung	Descripción Description	Measurement./Abm.	Norm
					Torque/Drehm.	Sealant Schmierstoff
1	5200009450	3	Piston Set Kolbensatz	Juego-pistón Jeu-piston		
2	5200009449	3	Connecting rod Pleuel	Biela Bielle		
3	5200009451	3	Ring Set Ringsatz	Juego de anillos Jeu de segments		
4	5200009470	3	Piston pin Kolbenbolzen	Pasador de pistón Axe de piston		
5	5200009471	3	Retaining clip Halteclip	Presilla de retención Clé de serrage		
6	5200009452	3	Bushing Buchse	Buje Douille		
7	5000155689	1	Bearing Lagerschalen	Rodamiento Roulement		
8	5000084175	6	Screw Schraube	Tornillo Vis		

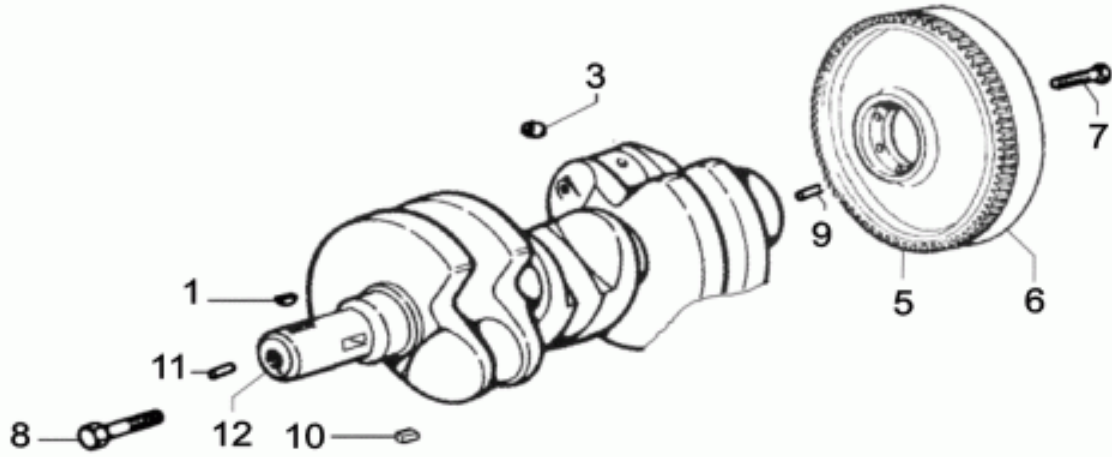

wc_ax0155357050_03

Ref. Pos.	Part No. Artikel Nr.	Qty. St.	Description Beschreibung	Descripción Description	Measurement/Abm.	Norm
					Torque/Drehm.	Sealant Schmierstoff
1	5000159260	1	Woodruff key Woodruffkeil	Chaveta Woodruff Clavette Woodruff		
3	5000159454	3	Plug (threaded) Schraubverschluß	Tapón roscado Bouchon		
5	5000155693	1	Gear crown Zahnkranz	Borde de engranaje Jante d'engrenage		
6	5000155694	1	Flywheel cpl. Schwungrad kpl.	Volante compl. Volant compl.		
7	5000160188	5	Bolt Bolzen	Perno Boulon		
8	5000126935	1	Bolt Bolzen	Perno Boulon		
9	5000159356	1	Pin Stift	Espiga Goupille		
10	5000159261	1	Square key Passfeder	Chaveta Clavette		
11	5000159357	1	Pin Stift	Espiga Goupille		
12	5000160365	1	Crankshaft Kurbelwelle	Cigüeñal Vilebrequin		

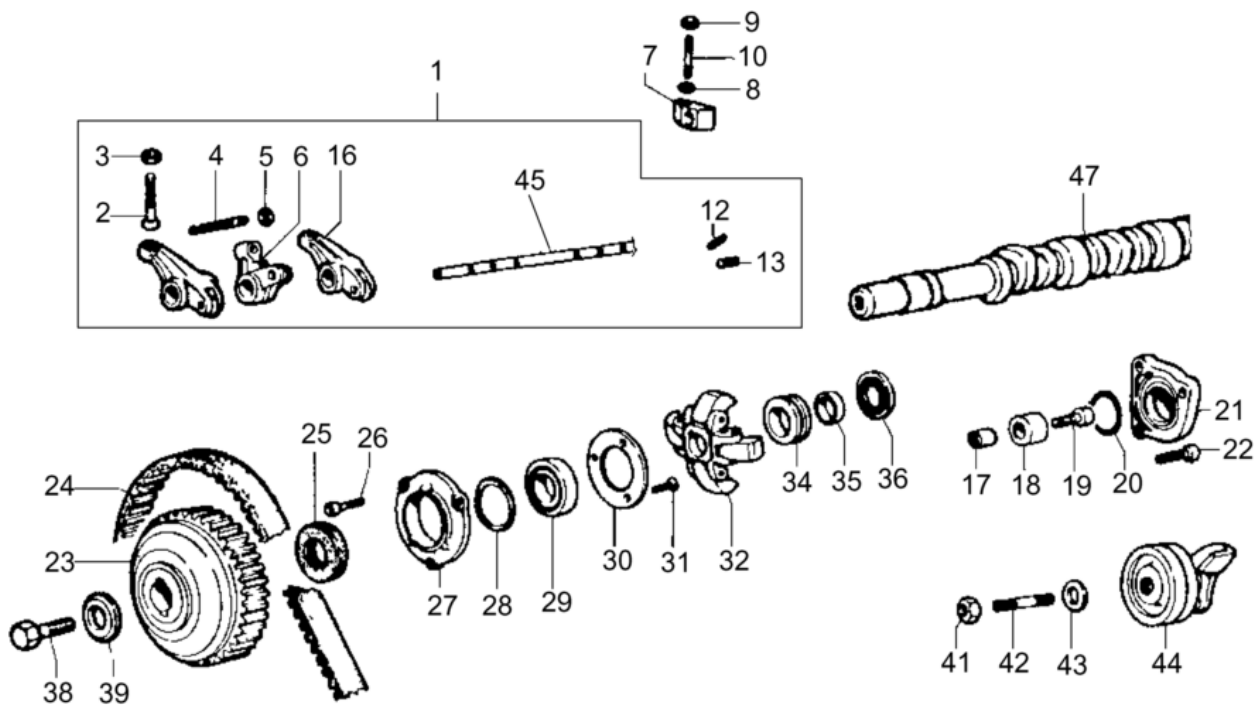

wc_ex0155357050_04

Ref. Pos.	Part No. Artikel Nr.	Qty. St.	Description Beschreibung	Descripción Description	Measur./Abm.	Norm
					Torque/Drehm.	Sealant Schmierstoff
1	5000155696	1	Rocker arm cpl. Kipphebel kpl.	Balancín compl. Culbuteur compl.		
2	5000159482	6	Screw Schraube	Tornillo Vis		
3	5000159272	6	Nut Mutter	Tuerca Écrou		
4	5000159483	3	Threaded bolt Gewindebolzen	Perno roscado Boulon fileté		
5	5000159275	3	Nut Mutter	Tuerca Ecrou		
6	5000159249	3	Rocker arm injector Kipphebel Einspritzdüse	Inyector de balancines L'injecteur de culbuteur		
7	5000159447	4	Shaft support Kipphebelbolzenkonsole	Soporte del eje de balancín Support de l'arbre de bascule		
8	5000159350	4	Washer Scheibe	Arandela Rondelle		
9	5000159274	4	Plug Stopfen	Tapón Bouchon		
10	5000159333	4	Threaded bolt Gewindebolzen	Perno roscado Boulon fileté		
12	5000159443	1	Pin Stift	Espiga Goupille		
13	5000159456	2	Plug Stopfen	Tapón Bouchon		
16	5000159248	6	Rocker arm Kipphebel	Balancín Culbuteur		
17	5000160752	1	Sleeve Hülse	Manguito Douille		
18	5000160754	1	Bushing Buchse	Buje Douille		
19	5000160763	1	Bolt Bolzen	Perno Boulon		
20	5000159234	1	Oil Seal Öldichtung	Junta de Aceite Joint D'Huile		
21	5000159282	1	Flange Flansch	Brida Bride		
22	5000159468	3	Screw Schraube	Tornillo Vis	M6 x 20	
23	5000159338	1	V-belt pulley Riemenscheibe	Polea Poulie		
24	5000155697	1	Timing belt Synchronriemen	Correa de sincronización Courroie de synchronisation		
25	5000159240	1	Lip seal Lippendichtung	Retén labial Joint à lèvres		
26	5000159467	3	Cover Deckel	Cubierta Couvercle		
27	5000159265	1	Cover Deckel	Cubierta Couvercle		
28	5000159239	1	O-Ring O-Ring	Anillo-O Joint torique		

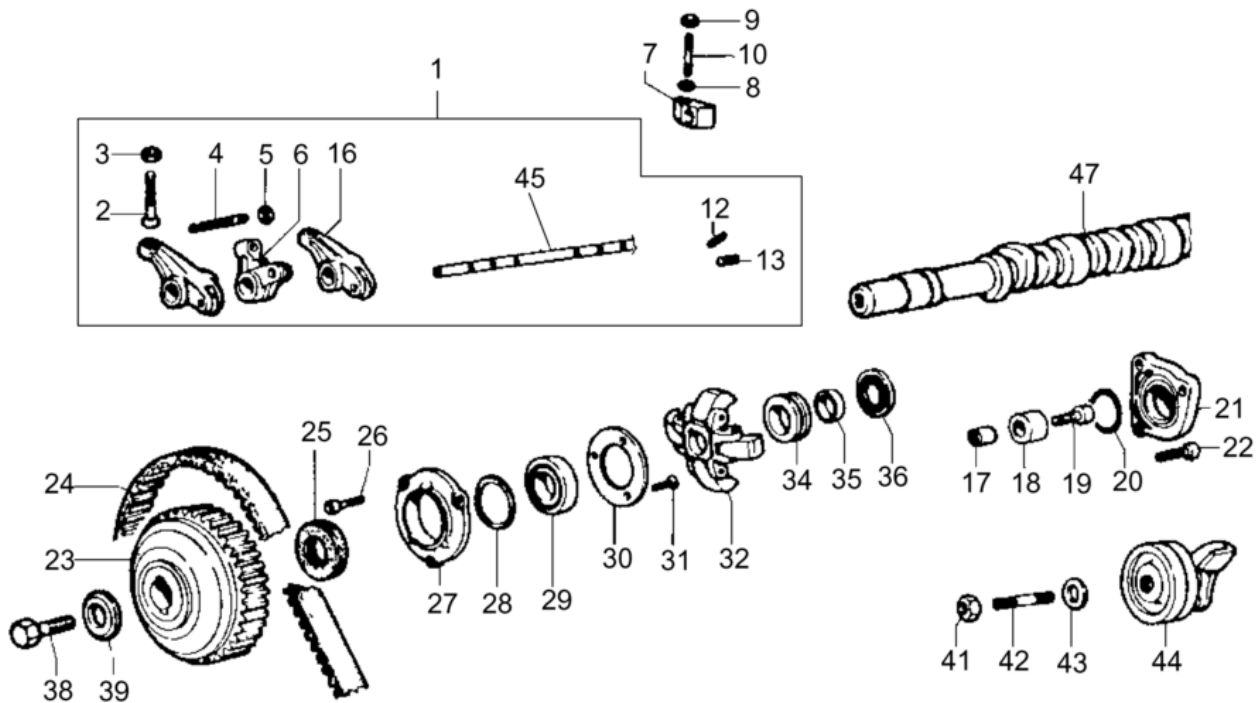

wc_ex0155357050_04

Ref. Pos.	Part No. Artikel Nr.	Qty. St.	Description Beschreibung	Descripción Description	Measurem./Abm.	Norm
					Torque/Drehm.	Sealant Schmierstoff
29	5000159267	1	Collar Hülse	Collar Douille		
30	5000159324	1	Check disc Anlaufscheibe	Arandela tope Disque		
31	5000159478	3	Screw Schraube	Tornillo Vis		
32	5000155698	1	Speed control module Drehzahlregler	Controlador de velocidad Régulateur de vitesse		
34	5000159310	1	Sleeve Hülse	Manguito Douille		
35	5000159251	1	Collar Hülse	Collar Douille		
36	5000159269	1	Bearing Lager	Rodamiento Roulement		
38	5000159481	1	Screw Schraube	Tornillo Vis		
39	5000159349	1	Washer Scheibe	Disco Rondelle		
41	5000159274	1	Plug Stopfen	Tapón Bouchon		
42	5000159334	1	Threaded bolt Gewindebolzen	Perno roscado Boulon fileté		
43	5000159344	1	Washer Scheibe	Disco Rondelle		
44	5000159284	1	Tensioner pulley Spannrolle	Polea tensora Poulie de tension		
45	5000160218	1	Rocker arm shaft Kipphebelwelle	Eje del balancín Arbre du culbuteur		
47	5000160751	1	Camshaft Nockenwelle	Arbol de levas Arbre à cames		

Crankcase cpl.
Kurbelgehäuse kpl.
Cárter compl.
Carter compl.

LTN6LE-V

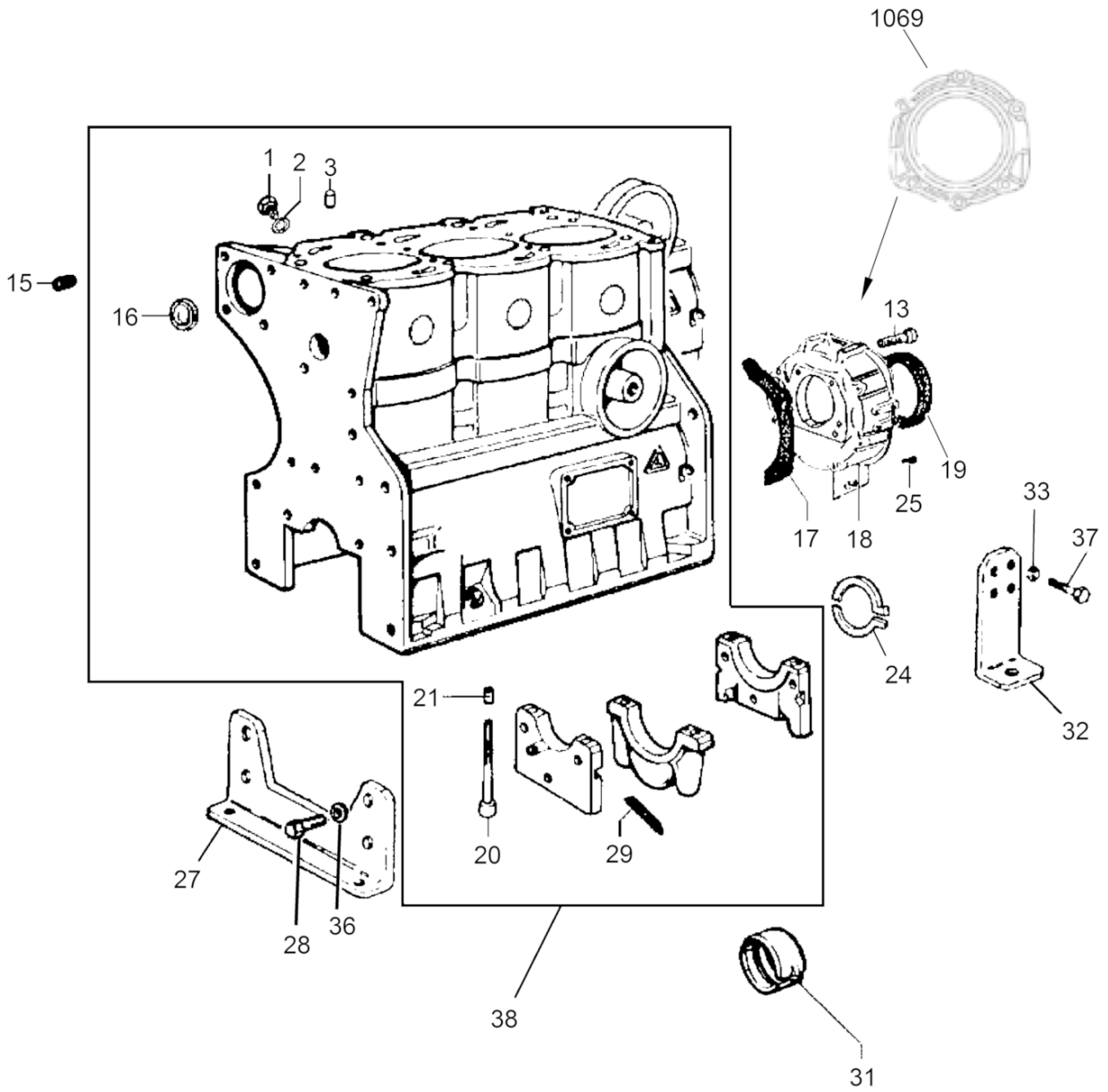

wc_ex0155357050_05

Ref. Pos.	Part No. Artikel Nr.	Qty. St.	Description Beschreibung	Descripción Description	Measur./Abm.	Norm
					Torque/Drehm.	Sealant Schmierstoff
1	5000082331	1	Plug (threaded) Schraubverschluß	Tapón roscado Bouchon		
2	5000082184	1	Ring seal Dichtring	Anillo sellador Rondelle à étancher		
3	5000159257	2	Sleeve Hülse	Collar Douille		
13	5000159467	6	Cover Deckel	Cubierta Couvercle		
15	5000082363	1	Screw Schraube	Tornillo Vis		
16	5000082335	6	Plug (threaded) Schraubverschluß	Tapón roscado Bouchon		
17	5000159296	1	Gasket Dichtung	Junta Joint		
18	5000160175	1	Flange Flansch	Brida Collerette		
19	5000103314	1	Ring seal Wellendichtring	Anillo sellador Rondelle à étancher		
20	5000159480	8	Screw Schraube	Tornillo Vis		
21	5000159257	8	Sleeve Hülse	Collar Douille		
24	5000159486	5	Washer Scheibe	Disco Rondelle		
24	5000159488	2	Disc Scheibe	Disco Disque		
24	5000159487	5	Disc Scheibe	Disco Disque		
25	5000159360	2	Dowel pin Paßstift	Espiga Cheville		
27	5000160225	1	Front mount Konsole (vorne)	Ménsula (delantera) Support d'avant		
28	5000160189	2	Bolt Bolzen	Perno Boulon	M12 x 1,75 x 25	
29	5000159288	4	Gasket Dichtung	Junta Joint		
31	5000155703	4	Bearing Lager	Cojinete Palier		
31	5000155702	4	Bearing Lager	Cojinete Palier		
31	5000155704	4	Bearing Lager	Cojinete Palier		
32	5000160226	2	Rear mount Konsole (hinten)	Ménsula (trasera) Support d'arrière		
33	5000160236	8	Washer Scheibe	Arandela Rondelle		
36	5000160236	2	Washer Scheibe	Arandela Rondelle		
37	5000160190	8	Bolt Bolzen	Perno Boulon	M8 x 1,25 x 20	

Crankcase cpl.
Kurbelgehäuse kpl.
Cárter compl.
Carter compl.

LTN6LE-V

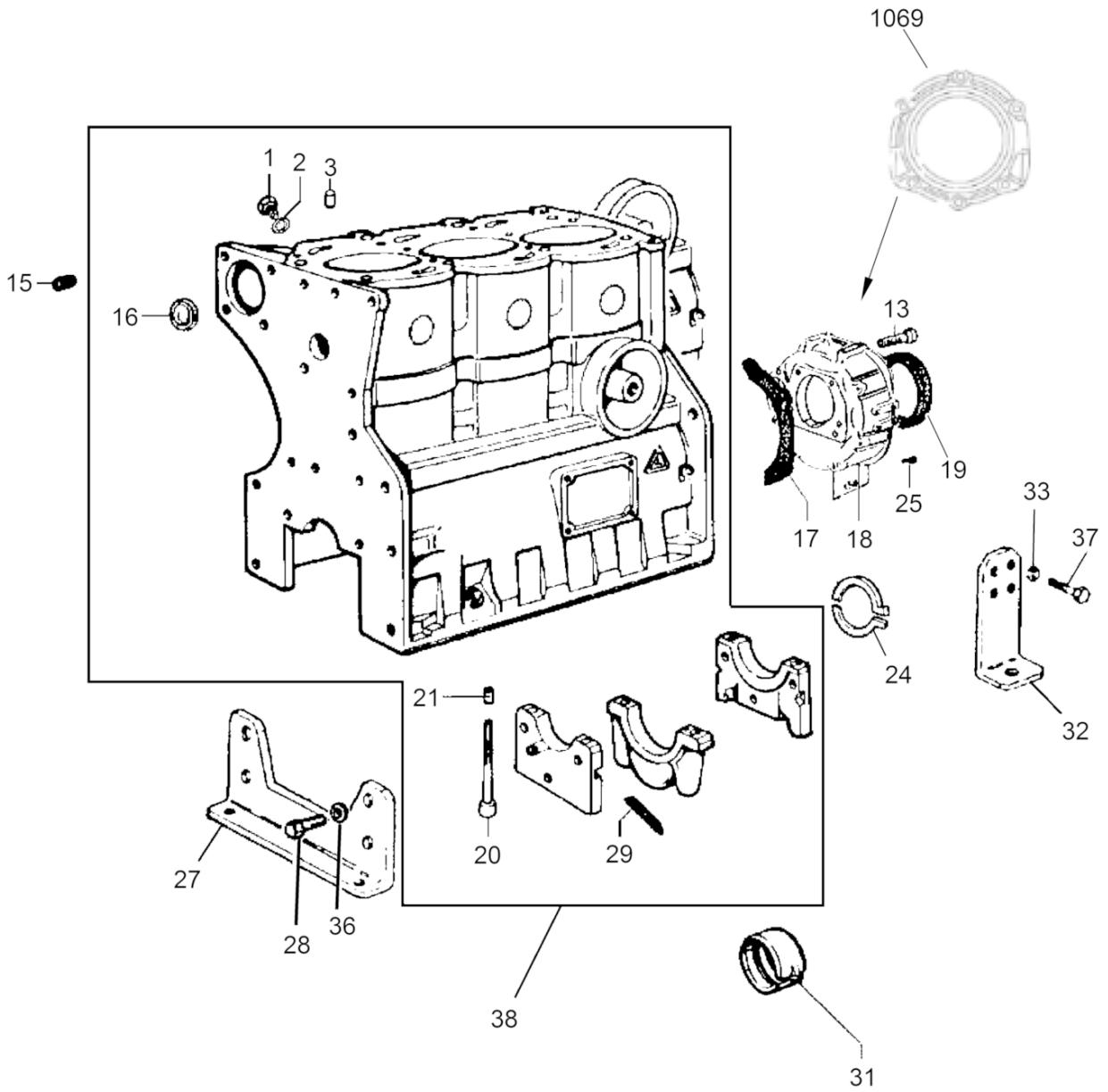

wc_ex0155357050_05

Ref. Pos.	Part No. Artikel Nr.	Qty. St.	Description Beschreibung	Descripción Description	Measuram./Abm.	Norm
					Torque/Drehm.	Sealant Schmierstoff
38	5000160366	1	Crankcase Kurbelgehäuse	Cárter Carter		
1069	5000155700	1	Flange Flansch	Brida Colerette		

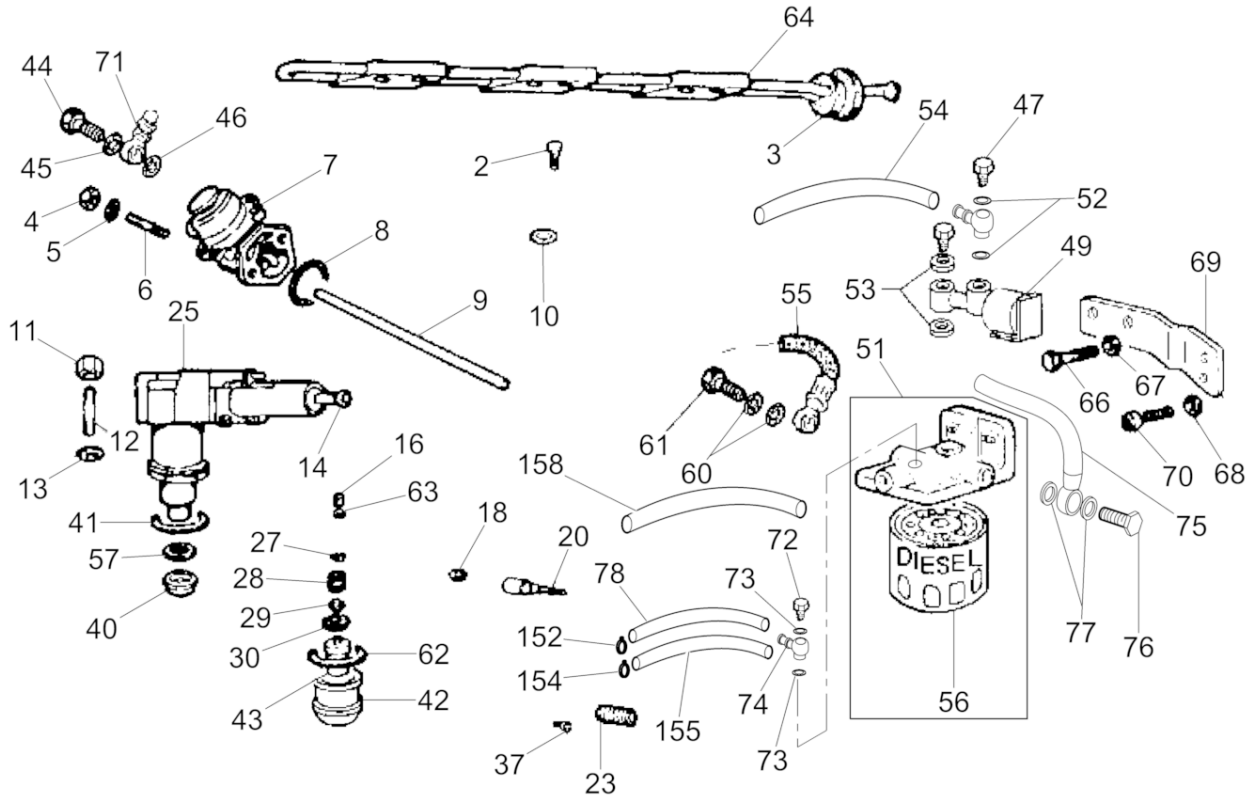

wc_ex0155357101_06

Ref. Pos.	Part No. Artikel Nr.	Qty. St.	Description Beschreibung	Descripción Description	Measur./Abm.	Norm
					Torque/Drehm.	Sealant Schmierstoff
2	5000159473	6	Screw Schraube	Tornillo Vis		
3	5000160209	1	Gasket Dichtung	Junta de estanqueidad Garniture		
4	5000063700	2	Flange nut Flanschmutter	Tuerca de reborde Ecrou de bride		
5	5000082285	2	Washer Scheibe	Arandela Rondelle		
6	5000084119	2	Stud Stiftschraube	Perno prisionero Boulon	M8 x 20	
7	5000155706	1	Fuel Pump Kraftstoffpumpe	Bomba de Combustible Pompe à Essence		
7	5000087254	1	Gasket Dichtung	Junta Joint		
7	5000227601	1	Piston Pump Kit Kolbenpumpe compl.	Bomba de pistón compl. Pompe à piston compl.		
8	5000110759	1	Seal Dichtung	Junta Joint		
9	5000159339	1	Fuel pump rod Kraftstoffpumpenstange	Varilla de bomba de combustible Tringle de pompe à essence	152.45 M	
10	5000159237	6	Ring Ring	Anillo Anneau		
11	5000082140	6	Nut Mutter	Tuerca Écrou		
12	5000159332	6	Threaded bolt Gewindebolzen	Perno roscado Boulon fileté		
13	5000082285	6	Washer Scheibe	Arandela Rondelle		
14	5000159246	3	Push rod (valve lifter) Stoßstange	Levantaválvula Poussoir de soupape		
16	5000160391	3	Back pressure valve Rückschlagventil	Válvula de retención Soupape de retenue		
18	5000155707	3	Fuel cock Kraftstoffhahn	Llave de combustible Robinet d'essence		
20	5000160378	3	Plunger Stößel	Émbolo Piston plongeur		
23	5000159317	3	Spring Feder	Resorte Ressort		
25	5000160379	3	Injection pump Einspritzpumpe	Bomba de inyección Pompe à injection		
27	5000160332	3	Spacer Abstandsstück	Espaciador Pièce d'écartement		
27	5000160333	3	Spacer Abstandsstück	Espaciador Pièce d'écartement	1,9	
27	5000160334	3	Spacer Abstandsstück	Espaciador Pièce d'écartement		
27	5000160335	3	Spacer Abstandsstück	Espaciador Pièce d'écartement		
27	5000160336	3	Spacer Abstandsstück	Espaciador Pièce d'écartement		

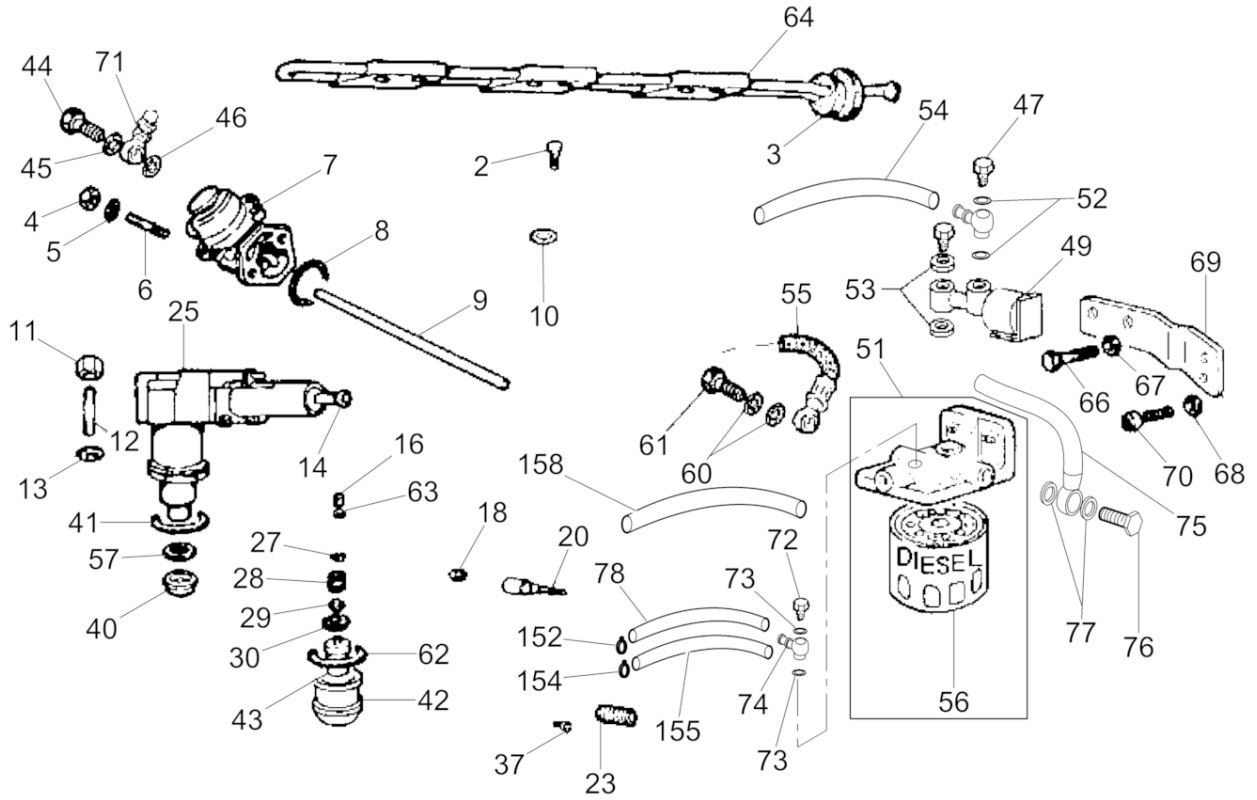

wc_ex0155357101_06

Ref. Pos.	Part No. Artikel Nr.	Qty. St.	Description Beschreibung	Descripción Description	Measurem./Abm.	Norm
					Torque/Drehm.	Sealant Schmierstoff
27	5000160337	3	Spacer Abstandsstück	Espaciador Pièce d'écartement		
27	5000160338	3	Spacer Abstandsstück	Espaciador Pièce d'écartement		
27	5000160339	3	Spacer Abstandsstück	Espaciador Pièce d'écartement		
27	5000160340	3	Spacer Abstandsstück	Espaciador Pièce d'écartement		
27	5000160341	3	Spacer Abstandsstück	Espaciador Pièce d'écartement		
27	5000160342	3	Spacer Abstandsstück	Espaciador Pièce d'écartement		
28	5000160379	1	Injection pump Einspritzpumpe	Bomba de inyección Pompe à injection		
29	5000160379	3	Injection pump Einspritzpumpe	Bomba de inyección Pompe à injection		
30	5000159278	3	Spacer Abstandsstück	Espaciador Pièce d'écartement		
37	5000159471	12	Screw Schraube	Tornillo Vis		
40	5000159318	3	Spark arrester Funkenfänger	Parachispas Pare-étincelles		
41	5000159233	3	O-Ring O-Ring	Anillo-O Joint torique		
42	5000159286	3	Nut Mutter	Tuerca Écrou		
43	5000155710	3	Jet Düse	Chicler Gicleur		
44	5000082105	2	Screw Schraube	Tornillo Vis		
45	5000082183	2	Ring seal Dichtring	Anillo sellador Rondelle à étancher		
46	5000082183	2	Ring seal Dichtring	Anillo sellador Rondelle à étancher		
47	5000082105	1	Screw Schraube	Tornillo Vis		
49	5000155711	1	Fuel valve Kraftstoffventil	Grifo de combustible Robinet de carburant		
51	5000205200	1	Fuel filter cpl. Kraftstofffilter kpl.	Filtro de combustible compl. Filtre à carburant compl.		
51	5000155712	1	Fuel filter holder Napf	Copilla Bol		
52	5000082183	2	Ring seal Dichtring	Anillo sellador Rondelle à étancher		
53	5000082185	2	Gasket Dichtung	Junta Joint		
54	5000155713	1	Hose Schlauch	Manguera Tuyau		
55	5000155714	1	Hose Schlauch	Manguera Tuyau		

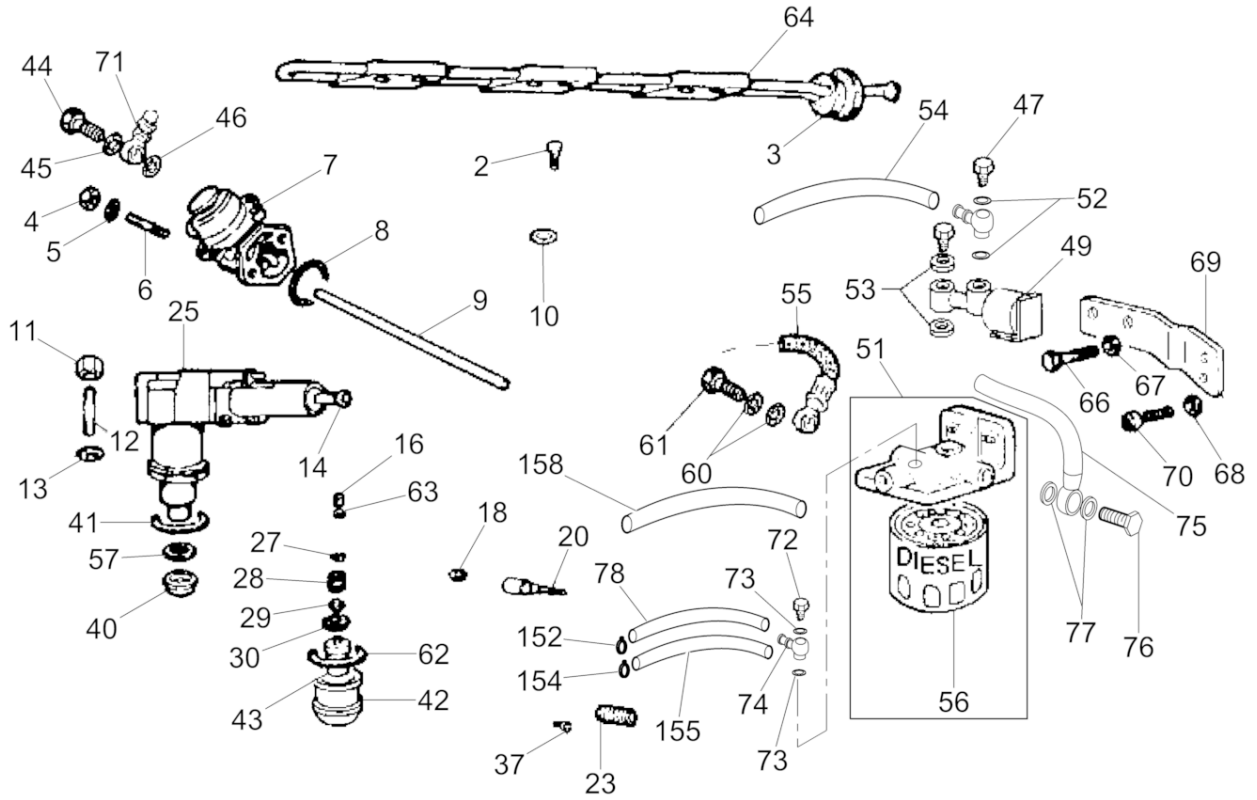

wc_ex0155357101_06

Ref. Pos.	Part No. Artikel Nr.	Qty. St.	Description Beschreibung	Descripción Description	Measurem./Abm.	Norm
					Torque/Drehm.	Sealant Schmierstoff
56	5000082116	1	Element Element	Elemento Cartouche		
57	5000159300	3	Washer Scheibe	Disco Rondelle		
60	5000082185	2	Gasket Dichtung	Junta Joint		
61	5000082107	1	Banjo bolt Hohlschraube	Perno hueco Boulon creux à filet femelle		
61	5000205203	1	Hollow screw Hohlschraubetil	Tornillo huecoora Boulon creux à filet femelle		
62	5000159238	3	O-ring O-Ring	Anillo-O Bague-O		
63	5000159302	3	Gasket Dichtung	Junta de estanqueidad Garniture		
64	5000159459	1	Pipe Rohr	Tubo Conduit		
66	5000082100	2	Screw Schraube	Tornillo Vis	M10 x 22	
67	5000160231	2	Washer Scheibe	Disco Rondelle		
68	5000160235	2	Washer Scheibe	Arandela Rondelle		
69	5000160346	1	Support bracket Unterstützungskonsole	Ménsula de soporte Console de support		
70	5000160363	2	Screw Schraube	Tornillo Vis	M8 x 20	
71	5000159342	1	Hose fitting Schlauchverschraubung	Unión de manguera Raccord de tuyau		
72	5000084231	2	Screw Schraube	Tornillo Vis		
73	5000083995	2	Washer Scheibe	Arandela Rondelle		
74	5000203362	1	Nipple Nippel	Boquilla roscada Raccord fileté		
75	5000205201	1	Fuel hose Kraftstoffleitung	Manguera de combustible Tuyau de carburant		
76	5000082107	1	Banjo bolt Hohlschraube	Perno hueco Boulon creux à filet femelle		
77	5000082185	1	Gasket Dichtung	Junta Joint		
78	5000205202	1	Fuel line Kraftstoffleitung	Manguera de combustible Conduit de carburant	ID 6, OD 12, 738	
152	5000082155	1	Clamp Schelle	Abrazadera Collier		
154	5000215704	1	Clamp Schelle	Abrazadera Attache		
155	5000210454	1	Fuel hose Kraftstoffleitung	Manguera de combustible Tuyau de carburant	ID 6, OD 12, 680	
158	5000209978	1	Fuel hose Kraftstoffleitung	Manguera de combustible Tuyau de carburant	ID 6, OD 12, 680	

Radiator cpl.
Kühler kpl.
Radiador compl.
Radiateur compl.

LTN6LE-V

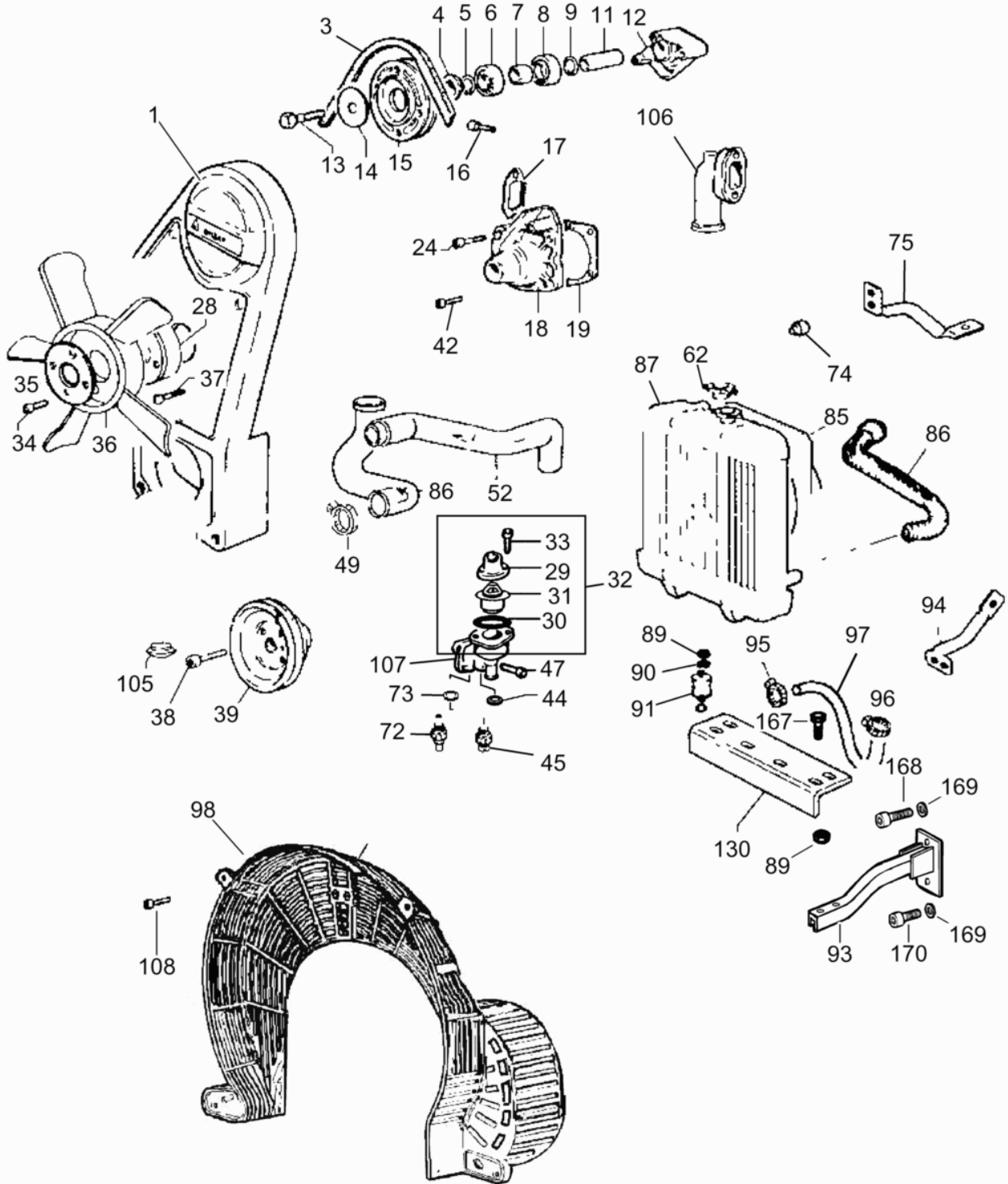

200_5000158995005_07

Ref. Pos.	Part No. Artikel Nr.	Qty. St.	Description Beschreibung	Descripción Description	Measurem./Abm.	Norm
					Torque/Drehm.	Sealant Schmierstoff
1	5000155716	1	Beltguard Riemenschutz	Guardacorrea Protection de courroie		
3	5200002703	1	Alternator belt Lichtmaschinenriemen	Correa del alternador Courroie de l'alternateur	850mm	
4	5000159347	1	Washer Scheibe	Disco Rondelle		
5	5000159241	1	Retaining ring Sicherungsring	Anillo de retención Bague d'arrêt		
6	5000082135	1	Bearing Lager	Cojinete Palier		
7	5000159277	1	Spacer Abstandsstück	Espaciador Pièce d'écartement		
8	5000082135	1	Bearing Lager	Cojinete Palier		
9	5000159241	1	Retaining ring Sicherungsring	Anillo de retención Bague d'arrêt		
11	5000159489	1	Pin Stift	Espiga Goupille	63,5	
12	5000159448	1	Console Konsole	Consola Console		
13	5000159490	1	Bolt Bolzen	Perno Boulon	M8x1.25x90	
14	5000159346	1	Washer Scheibe	Disco Rondelle		
15	5000155718	1	Pulley Scheibe	Polea Poulie		
16	5000160362	2	Screw Schraube	Tornillo Vis		
17	5000159293	1	Gasket Dichtung	Junta Joint		
18	5000155719	1	Water pump cpl. Wasserpumpe kpl.	Bomba del agua compl. Pompe à eau compl.		
19	5000159298	1	Gasket Dichtung	Junta Joint		
24	5000084171	2	Screw Schraube	Tornillo Vis		
28	5000160202	1	Fan flange Gebläseradflansch	Brida del ventilador Collerette du ventilateur		
29	5000159266	1	Thermostat cover Thermostatdeckel	Tapa del termóstato Couvercle du thermostat		
30	5000159232	1	O-Ring O-Ring	Anillo-O Joint torique		
31	5000207002	1	Valve-thermostat Thermostatventil	Válvula de gobierno termostático Soupape thermostatique		
32	5000160372	1	Housing Gehäuse	Caja Carter		
33	5000084169	2	Screw Schraube	tornillo vis		
34	5000159470	4	Screw Schraube	Tornillo Vis	M6 x 1 x 60	

Radiator cpl.
 Kühler kpl.
 Radiador compl.
 Radiateur compl.

LTN6LE-V

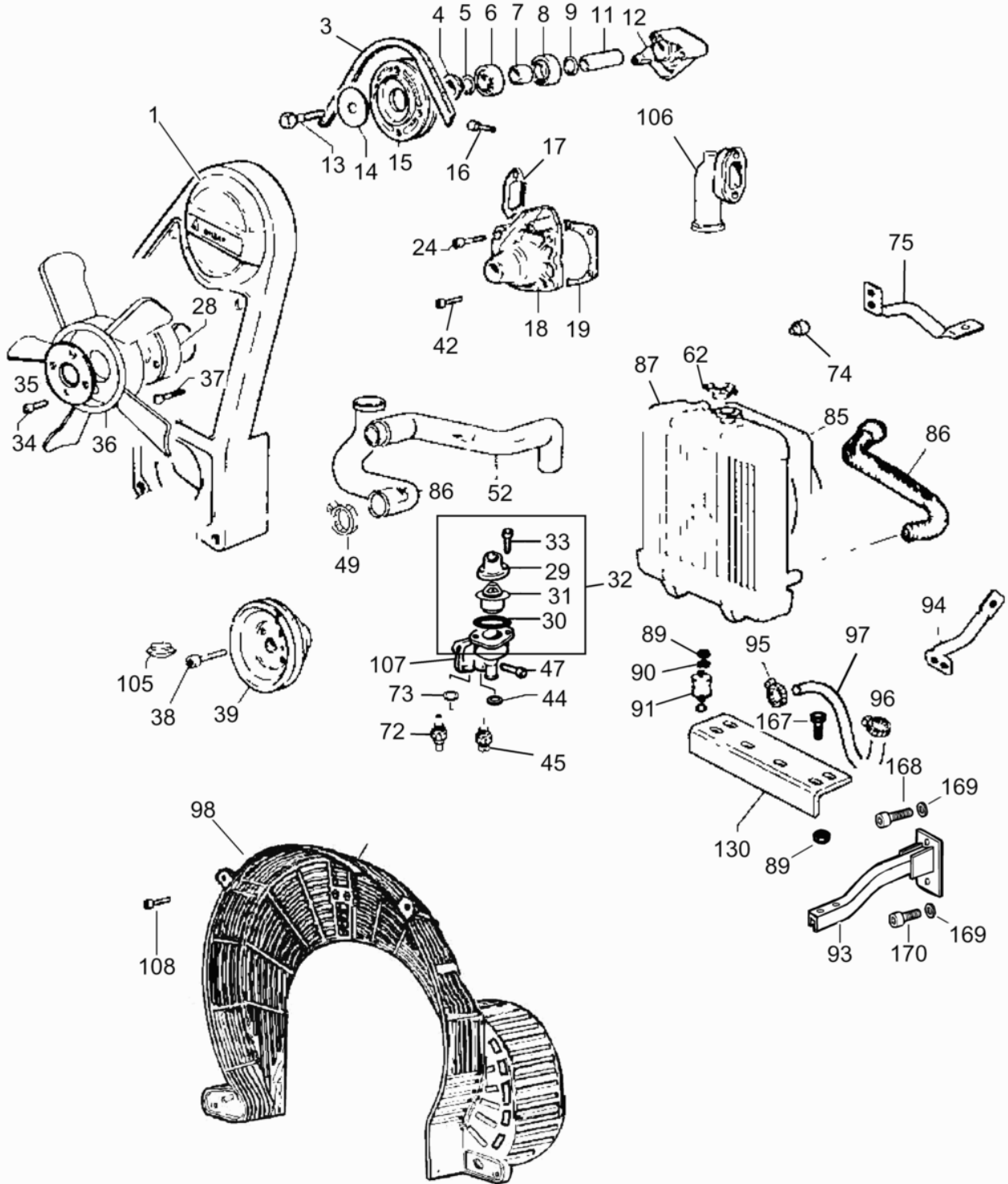

200_5000158995005_07

Ref. Pos.	Part No. Artikel Nr.	Qty. St.	Description Beschreibung	Descripción Description	Measur./Abm.	Norm
					Torque/Drehm.	Sealant Schmierstoff
35	5000159323	1	Plate Platte	Placa Plaque		
36	5000155722	1	Fan Gebläserad	Ventilador Ventilateur		
37	5000160362	4	Screw Schraube	Tornillo Vis		
38	5000159475	4	Screw Schraube	tornillo vis		
39	5000155723	1	Crankshaft pulley Scheibe	Disco Rondelle		
42	5000159469	2	Screw Schraube	Tornillo Vis	M8 x 16	
44	5000159299	1	Washer Scheibe	Disco Rondelle		
45	5000160387	1	Sensor Sensoreinheit	Unidad de alerta Appareil d'alerte		
47	5000159476	2	Screw Schraube	Tornillo Vis		
49	5000160200	4	Clamp Schelle	Abrazadera Agrafe		
52	5000155725	1	Hose Schlauch	Manguera Tuyau		
62	5200003931	1	Cap Kappe	Tapa Capuchon		
72	5000155726	1	Temperature sensor Temperatursensoreinheit	Unidad de alerta de temperatura Appareil d'alerte de températu		
73	5000082185	1	Gasket Dichtung	Junta Joint		
74	5000155727	2	Shockmount Puffer	Amortiguador Silentbloc	0,25	
75	5000213454	1	Brace Strebe	Apoyo Ventreière		
85	5000213455	1	Shroud Haube	Guardera Carénage		
86	5000155732	1	Hose Schlauch	Manguera Tuyau		
87	5000215728	1	Radiator Kühler	Radiator Radiateur		
89	5000160198	2	Nut Mutter	Tuerca Écrou	M8	
90	5000082292	2	Washer Scheibe	Arandela Rondelle		
91	5000155728	2	Shockmount Puffer	Amortiguador Silentbloc	0,30	
92	5000082292	2	Washer Scheibe	Arandela Rondelle		
93	5000155733	1	Bracket Konsole	Soporte Support		
94	5000160353	1	Brace Strebe	Apoyo Ventreière		

Radiator cpl.
Kühler kpl.
Radiador compl.
Radiateur compl.

LTN6LE-V

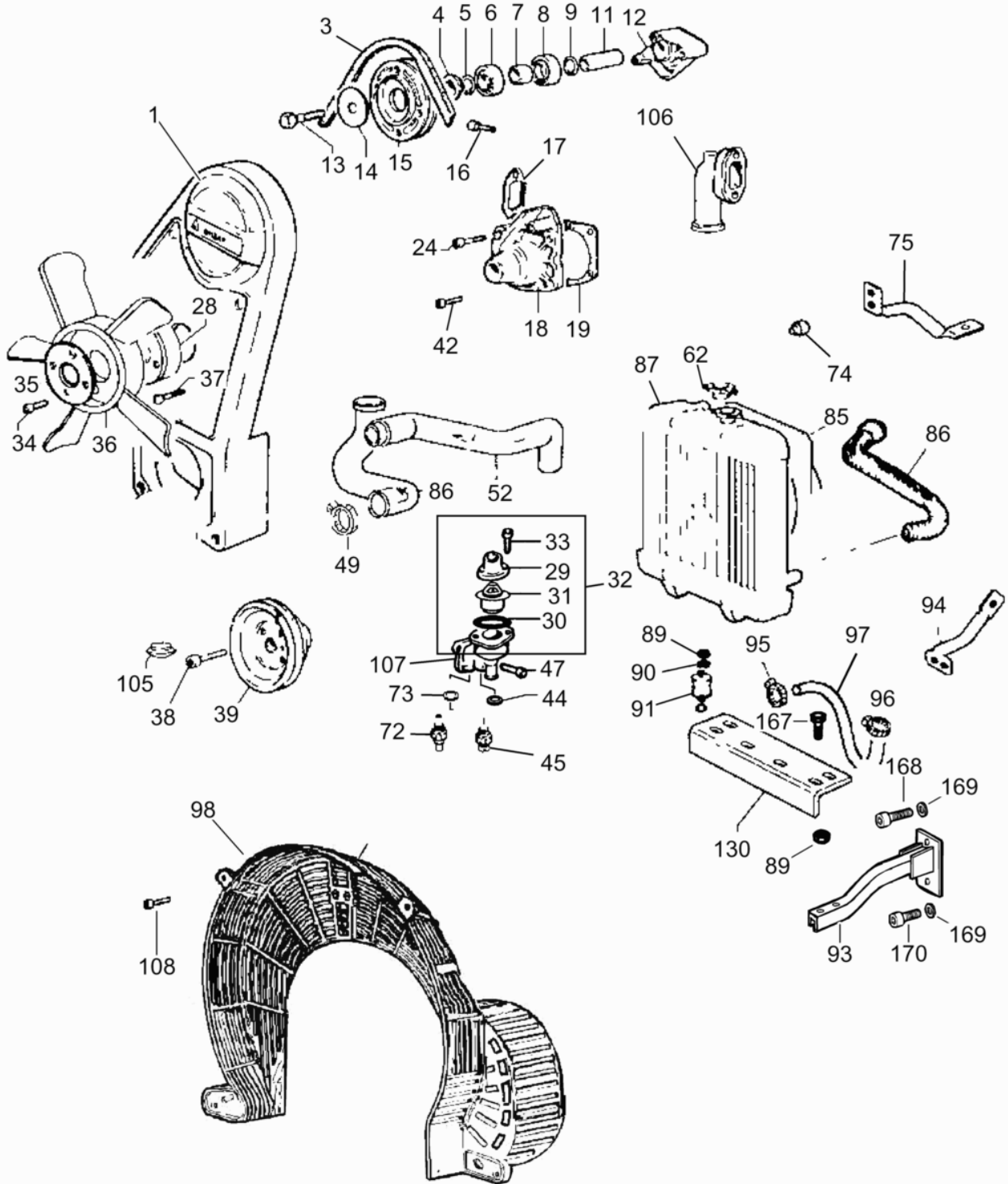

200_5000158995005_07

Ref. Pos.	Part No. Artikel Nr.	Qty. St.	Description Beschreibung	Descripción Description	Measurement/Abm.	Norm
					Torque/Drehm.	Sealant Schmierstoff
95	5000160200	1	Clamp Schelle	Abrazadera Agrafe		
96	5000160201	1	Clamp Schelle	Abrazadera Attache		
97	5000160355	1	Water pipe Wasserrohr	Caño de agua Tube d'eau		
98	5200002704	1	Fan guard Lüfterhaube	Guardaventilador Bague de ventilateur		
104	5000165574	1	Spacer Abstandsstück	Espaciador Entretoise		
105	5000159268	1	Plug Stopfen	Enchufe Prise		
106	5000155729	1	Hose/water flange Flansch-Schlauch/Wasser	Brida-manguera/agua Colerette-tuyau/eau		
107	5000207003	1	Gasket Dichtung	Junta Joint		
108	5000213457	4	Pan head screw Flachkopfschraube	Tornillo de cabeza de cono achatado Vis ber	M6	
130	5000213463	1	Mount Konsole	Ménsula Support		
167	5000215693	2	Bolt Bolzen	Perno Boulon		
168	5000215741	2	Screw Schraube	Tornillo Vis	M12 x 30	
169	5000160236	4	Washer Scheibe	Arandela Rondelle		
170	5000215740	2	Screw Schraube	Tornillo Vis	M12 x 20	

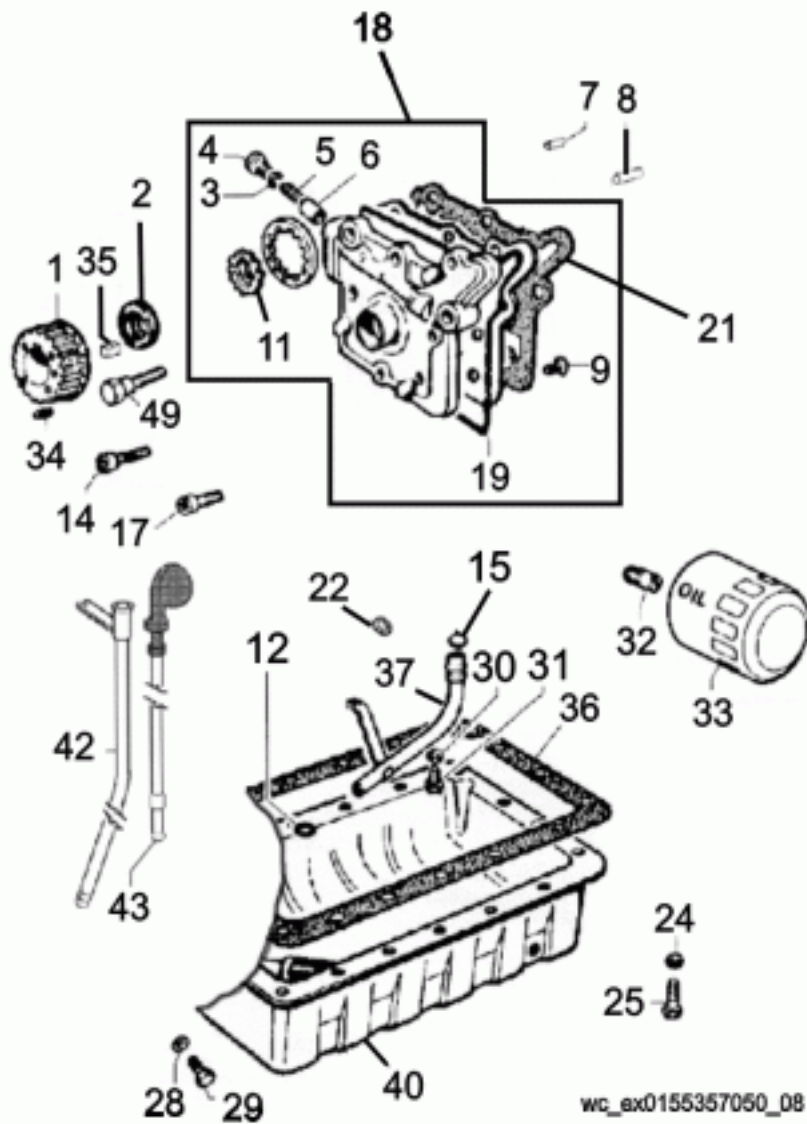

wc_ax0155357050_08

Ref. Pos.	Part No. Artikel Nr.	Qty. St.	Description Beschreibung	Descripción Description	Measurem./Abm.	Norm
					Torque/Drehm.	Sealant Schmierstoff
1	5000159336	1	V-belt pulley Riemenscheibe	Polea Poulie		
2	5000155734	1	Ring seal Dichtungsring	Anillo sellador Rondelle à étancher		
3	5000082184	1	Ring seal Dichtring	Anillo sellador Rondelle à étancher		
4	5000159450	1	Screw Locking Schraubverschluß	Cierre Roscada Fermeture de Vissage		
5	5000159312	1	Spring Feder	Resorte Ressort		
6	5000159330	1	Rod Stange	Varilla Tige		
9	5000159478	3	Screw Schraube	Tornillo Vis		
11	5000160326	1	Rotor Rotor	Rotor Rotor		
12	5000159228	1	Oil Seal Öldichtung	Junta de Aceite Joint D'Huile		
14	5000159476	1	Screw Schraube	Tornillo Vis		
15	5000159235	1	O-Ring O-Ring	Anillo-O Joint torique		
17	5000084169	6	Screw Schraube	tornillo vis		
18	5000155735	1	Oil pump cpl. Ölpumpe kpl.	Bomba de aceite compl. Pompe à huile compl.		
19	5000160178	1	O-Ring O-Ring	Anillo-O Joint torique		
21	5000159566	1	Gasket Dichtung	Junta Joint		
22	5000159565	2	O-Ring O-Ring	Anillo-O Joint torique		
24	5000159567	18	Washer Scheibe	Arandela Rondelle		
25	5000159253	18	Bolt Bolzen	Perno Boulon		
28	5000159568	2	Washer Scheibe	Arandela Rondelle		
29	5000159452	2	Plug Stopfen	Tapón Bouchon	M18	
30	5000159348	1	Washer Scheibe	Arandela Rondelle		
31	5000159253	1	Bolt Bolzen	Perno Boulon		
32	5000159341	1	Fitting-oil filter Ölfilterverschraubung	Unión de filtro de aceite deaceite Raccord de filtre d'huile		
33	5000155736	1	Oil filter Ölfilter	Filtro de aceite Filtre d'huile		
35	5000160195	1	Key Keil	Llave Clé	12	

Ref. Pos.	Part No. Artikel Nr.	Qty. St.	Description Beschreibung	Descripción Description	Measurement./Abm.	Norm
					Torque/Drehm.	Sealant Schmierstoff
36	5000159291	1	Gasket Dichtung	Junta Joint		
37	5000160389	1	Hose Schlauch	Manguera Tuyau		
40	5000155738	1	Oil pan Ölwanne	Colector de aceite Cuvette-carter à huile		
42	5000155739	1	Protection Schutz	Protecciónel de aceite Protection		
43	5000155740	1	Oil dipstick Ölpeilstab	Indicador del nivel de aceite Réglette-jauge d'huile		
49	5000159484	2	Screw Schraube	Tornillo Vis		

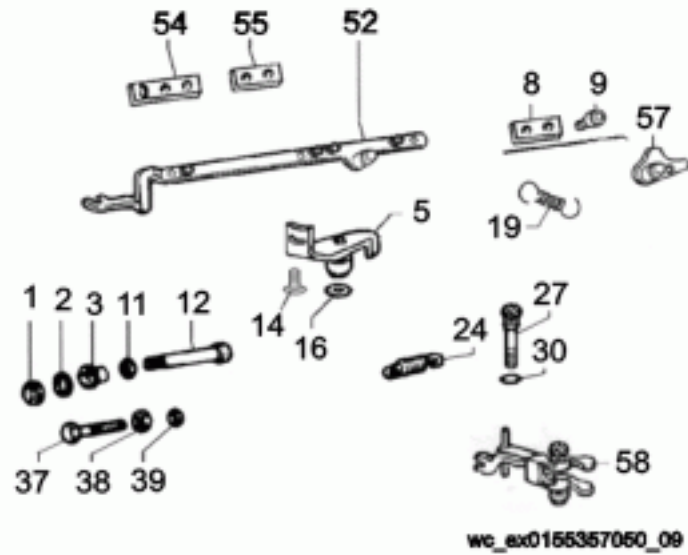

Ref. Pos.	Part No. Artikel Nr.	Qty. St.	Description Beschreibung	Descripción Description	Measurem./Abm.	Norm
					Torque/Drehm.	Sealant Schmierstoff
1	5000159276	1	Nut Mutter	Tuerca Écrou		
2	5000083995	1	Washer Scheibe	Arandela Rondelle		
3	5000160204	1	Nut Mutter	Tuerca Écrou		
5	5000160214	1	Lever Hebel	Palanca Levier		
8	5000160222	2	Plate Platte	Placa Plaque		
9	5000159477	4	Screw Schraube	Tornillo Vis		
11	5000159292	1	Gasket Dichtung	Junta de estanqueidad Garniture		
12	5000160386	1	Fuel valve Kraftstoffhahn	Grifo de combustible Robinet de carburant		
14	5000082365	1	Screw Schraube	Tornillo Vis	M5 x 7	
16	5000159230	1	Oil Seal Öldichtung	Junta de Aceite Joint D'Huile		
19	5000159315	1	Spring Feder	Resorte Ressort		
24	5000217832	1	Governor spring Reglerfeder	Resorte del regulador Ressort régulateur		
24	5000155742	1	Spring Feder	Resorte Ressort		
27	5000159321	1	Pin Stift	Espiga Goupille		
30	5000159229	1	Oil Seal Öldichtung	Junta de Aceite Joint D'Huile		
37	5000084131	1	Screw Schraube	Tornillo Vis		
38	5000159270	1	Nut Mutter	Tuerca Écrou		
39	5000083995	1	Washer Scheibe	Arandela Rondelle		
52	5000159245	1	Linkage Gestänge	Varillaje Tringles		
54	5000160221	1	Plate Platte	Placa Plaque		
55	5000160220	1	Plate Platte	Placa Plaque		
57	5000159325	1	Plate Platte	Placa Plaque		
58	5000155743	1	Governor lever Reglerhebel	Palanca del gobernador Levier régulateur		

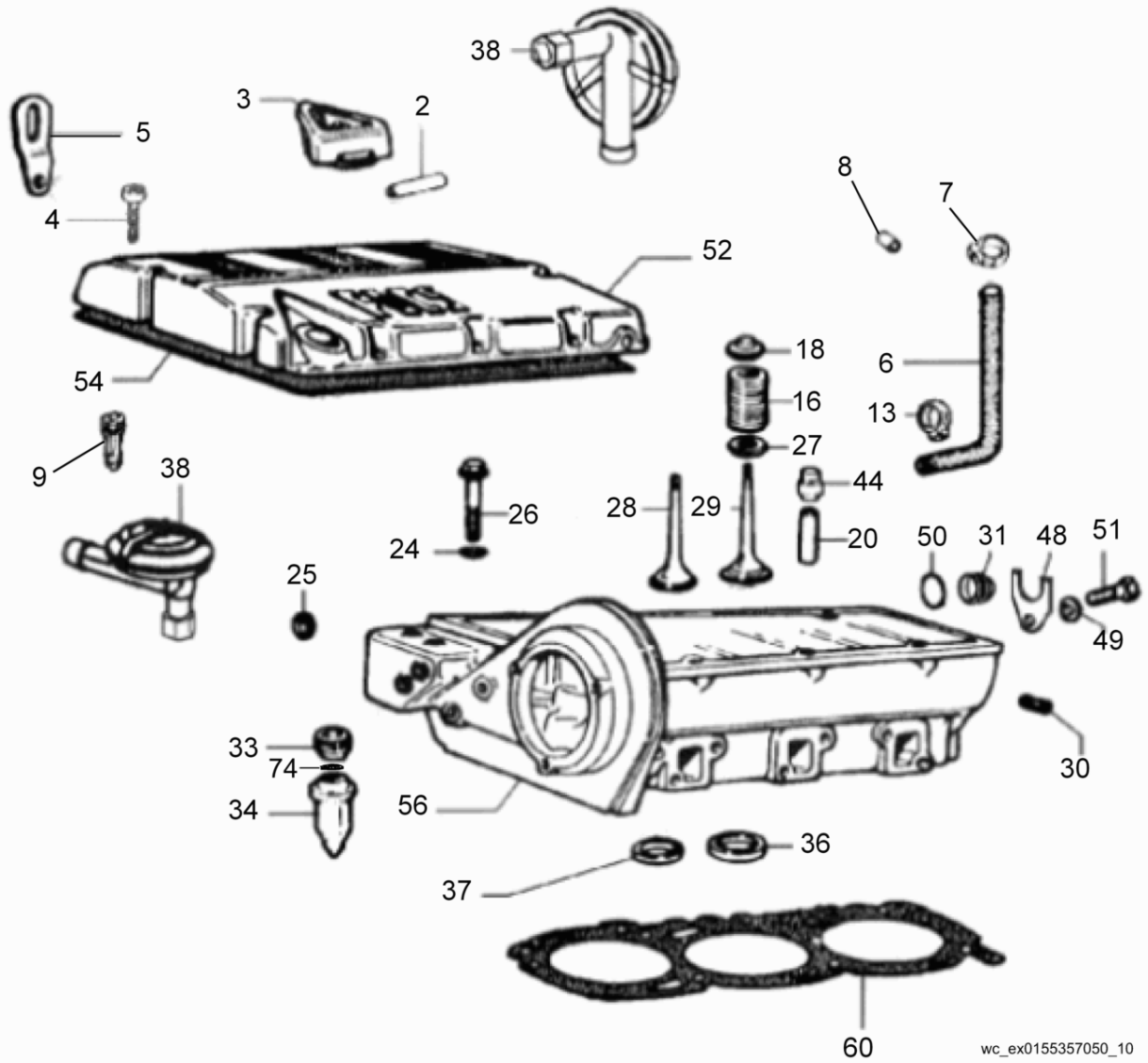

wc_ex0155357050_10

Ref. Pos.	Part No. Artikel Nr.	Qty. St.	Description Beschreibung	Descripción Description	Measurem./Abm.	Norm
					Torque/Drehm.	Sealant Schmierstoff
2	5000159461	1	Breather tube Entlüftungsrohr	Tubo respiradero Tube reniflard		
3	5000155744	1	Oil filler cap Kappe-Ölfüller	Llenador de aceite Remplisseur d'huile		
4	5000159468	12	Screw Schraube	Tornillo Vis	M6 x 20	
5	5000159445	2	Lifting bracket Hebebügel	Ménsula alzadora Support de relèvement		
6	5000159460	1	Tube Rohr	Tubo Tube		
7	5000160201	1	Clamp Schelle	Abrazadera Attache		
8	5000159455	1	Push-in plug Stopfen	Tapón Bouchon		
9	5000159308	1	Connector Anschlußteil	Conector Connexion		
13	5000160199	1	Clamp Schelle	Abrazadera Agrafe		
16	5000160373	6	Spring Ventilfeder	Resorte Ressort		
18	5000159328	6	Spring Housing Federgehäuse	Carcasa de Resorte Logement du Ressort		
20	5000159303	6	Valve guide Ventilführung	Guía de válvula Guide de soupape		
24	5000159350	8	Washer Scheibe	Arandela Rondelle		
25	5000159449	2	Plug Stopfen	Enchufe Prise		
26	5000159479	8	Bolt Bolzen	Perno Boulon		
27	5000159351	6	Washer Scheibe	Disco Rondelle		
28	5000160392	3	Outlet valve Auslaßventil	Válvula de escape Soupape d'échappement		
29	5000160390	3	Intake valve Einlaßventil	Válvula de admisión Soupape d'admission		
30	5000159454	2	Plug (threaded) Schraubverschluß	Tapón roscado Bouchon		
31	5000159453	1	Plug Stopfen	Enchufe Prise		
33	5000159285	3	Nut Mutter	Tuerca Ecrou		
34	5000160380	3	Precombustion chamber Vorkammer	Cámara de precombustión Préchambre		
36	5000160381	3	Seat-valve, intake Sitz des Einlassventils	Asiento de la válvula de admisión Siège de la soupape		
37	5000160382	3	Seat-valve, exhaust Sitz des Auslassventils	Asiento de la válvula de escape Siège de la soupape		
38	5000155745	1	Pressure valve Überdruckventil	Válvula de sobrepresión Soupape de surpression		

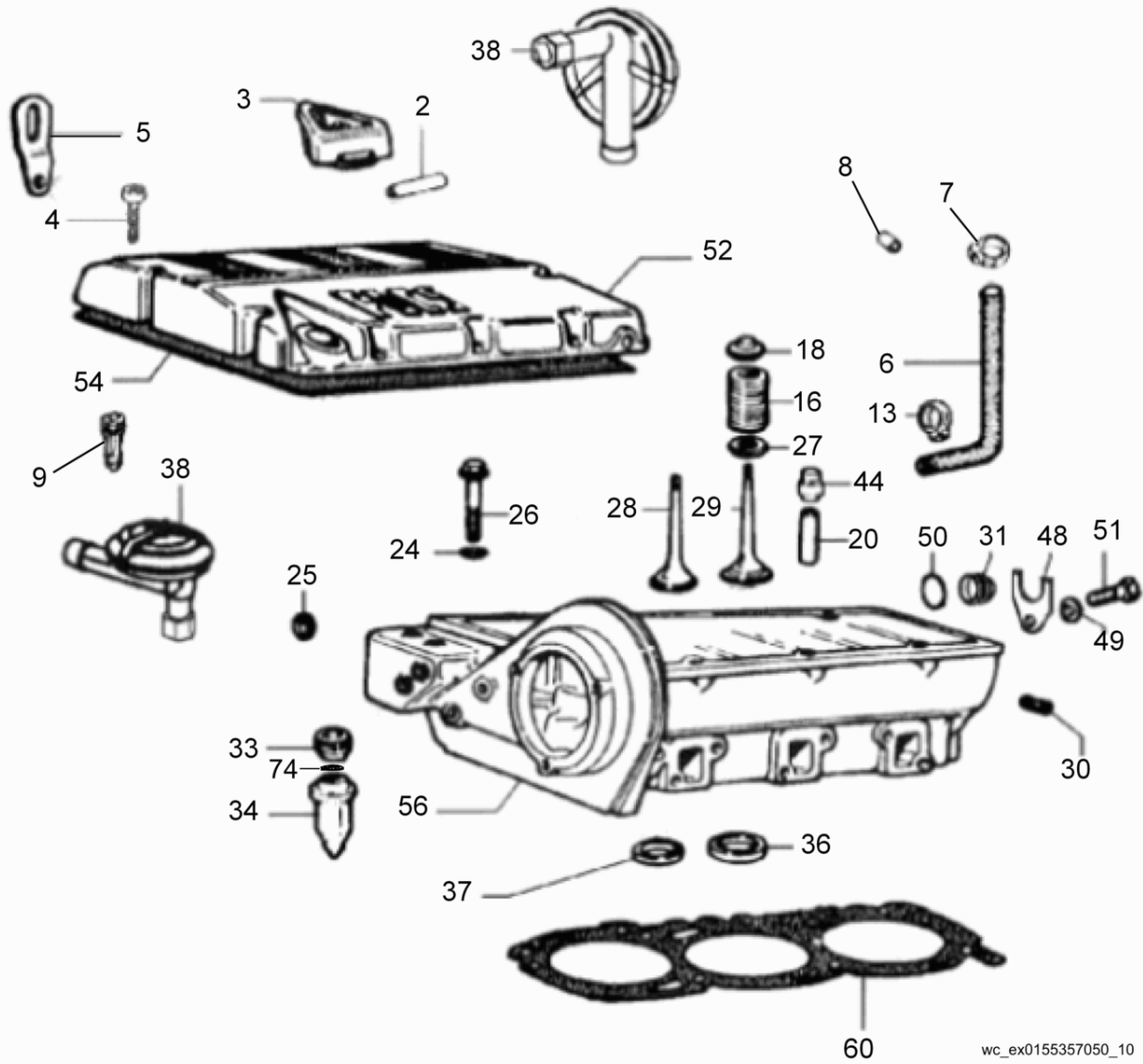

wc_ex0155357050_10

Ref. Pos.	Part No. Artikel Nr.	Qty. St.	Description Beschreibung	Descripción Description	Measurem./Abm.	Norm
					Torque/Drehm.	Sealant Schmierstoff
44	5000159297	6	Gasket Dichtung	Junta Joint		
48	5000159311	1	Bracket Halter	Soporte Équerre		
49	5000082292	1	Washer Scheibe	Arandela Rondelle		
50	5000159231	1	O-ring O-ring	Anillo en forma de o Joint torique		
51	5000159254	1	Bolt Bolzen	Perno Boulon		
52	5000155746	1	Cover Deckel	Tapa Couvercle		
54	5000160205	1	Gasket Dichtung	Junta Joint		
56	5000160388	1	Cylinder head Zylinderkopf	Culata Culasse		
60	5000160369	1	Cylinder head gasket (1) notch Zylinderkopfdichtung mit Schlitz (1)	Junta de culata del cilindro con entalladura (1) Joint de culasse de cylindre a		
60	5000160370	1	Cylinder head gasket (2) notch Zylinderkopfdichtung mit Schlitz (2)	Junta de culata del cilindro con entalladura (2) Joint de culasse de cylindre a		
60	5000160371	1	Cylinder head gasket (3) notch Zylinderkopfdichtung mit Schlitz (3)	Junta de culata del cilindro con entalladura (3) Joint de culasse de cylindre a		
74	5000215494	1	Spacer Abstandsstück	Espaciador Pièce d'écartement		

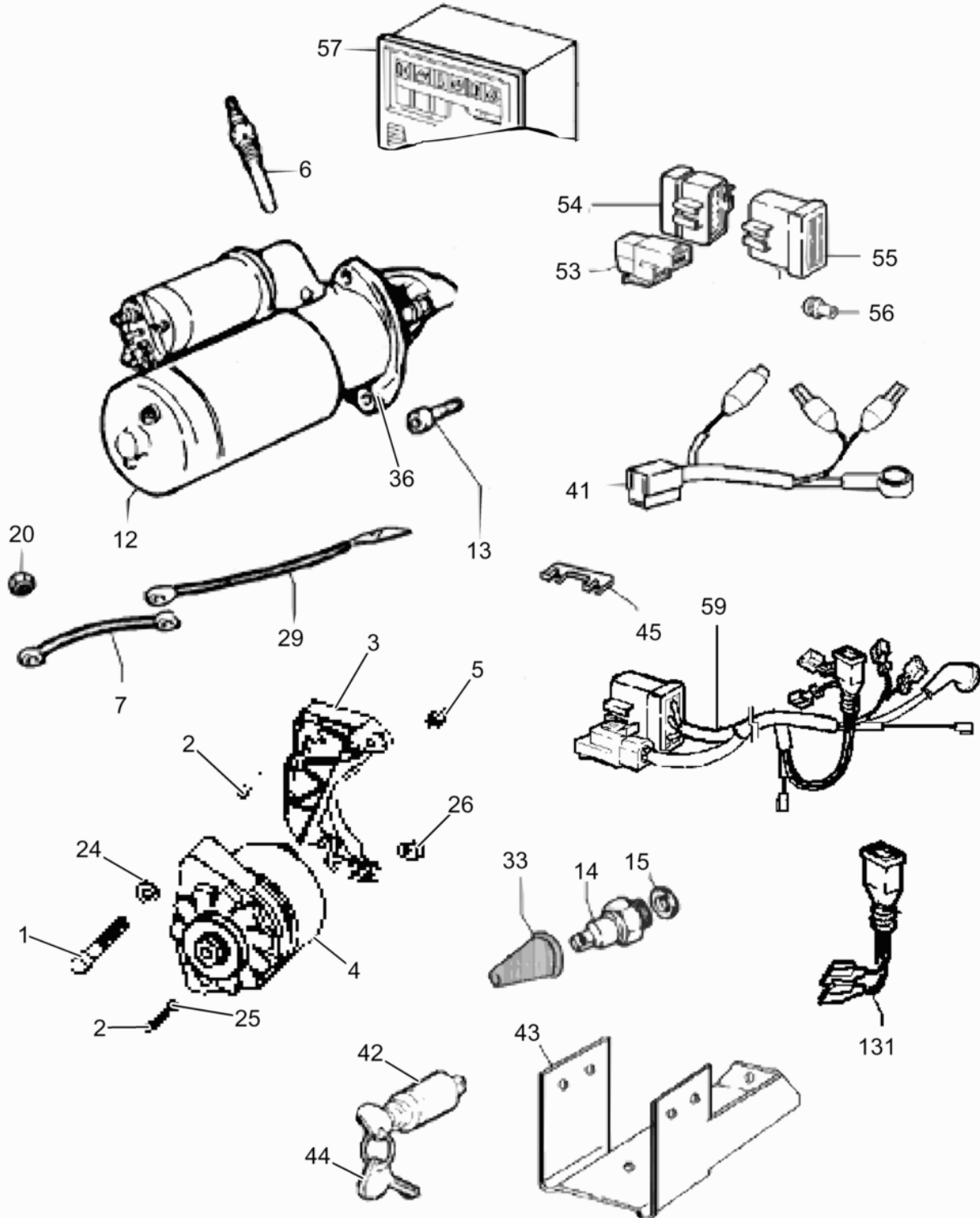

200_500015899502_11

Ref. Pos.	Part No. Artikel Nr.	Qty. St.	Description Beschreibung	Descripción Description	Measurem./Abm.	Norm
					Torque/Drehm.	Sealant Schmierstoff
1	5200002696	1	Bolt Bolzen	Perno Boulon	M10 x 75	
2	5200002695	3	Bolt Bolzen	Perno Boulon	M8 x 45	
3	5200002702	1	Alternator support Konsole für Lichtmaschine	Soporte para alternador Support pour alternateur		
4	5200002694	1	Alternator Lichtmaschine	Alternador Alternateur	12V/33-40A	
5	5000083011	1	Nut Mutter	Tuerca Ecrou		
6	5000155748	3	Glow plug Glühkerze	Tapón luminoso Bougie de préchauffage		
7	5000159259	2	Cable Kabel	Cable Câble		
12	5000160374	1	Starter Motor Anlasser	Motor de Arranque Démarreur		
13	5000084164	2	Screw Schraube	Tornillo Vis		
14	5000155751	1	Oil pressure switch Öldruckschalter	Interruptor de presión de aceite Interrupteur à pression d'huile	20 PSI/4 BAR	
15	5000082184	4	Ring seal Dichtring	Anillo sellador Rondelle à étancher		
20	5000215492	3	Hexagon nut Sechskantmutter	Tuerca hexagonal Écrou hexagonal		
24	5200002701	1	Washer Scheibe	Arandela Rondelle	10mm	
25	5200002700	1	Washer Scheibe	Arandela Rondelle		
26	5200002698	1	Plate Platte	Placa Plaque		
29	5000160194	1	Wire-glow plug Glühkerzenkabel	Alambre para tapón encendedor Câble pour bougie de		
33	5000082254	1	Rubber funnel Gummitülle	Casquillo de goma Passe fil en caoutchouc		
36	5000206968	1	Flange Flansch	Brida Bride		
41	5000155752	1	Wire Kabel	Alambre Fil		
42	5000165577	1	Key switch Schlüsselschalter	Interruptor de llave Interrupteur de clé		
43	5000160345	1	Bracket Konsole	Soporte Support		
44	5000165578	1	Key Passfeder	Llave Clé		
45	5000155753	1	Fuse Sicherung	Fusible Fusible	80A	
53	5000160184	2	Connector Anschlußteil	Conector Connecteur		
54	5000160183	1	Connector Anschlußteil	Conector Connecteur		

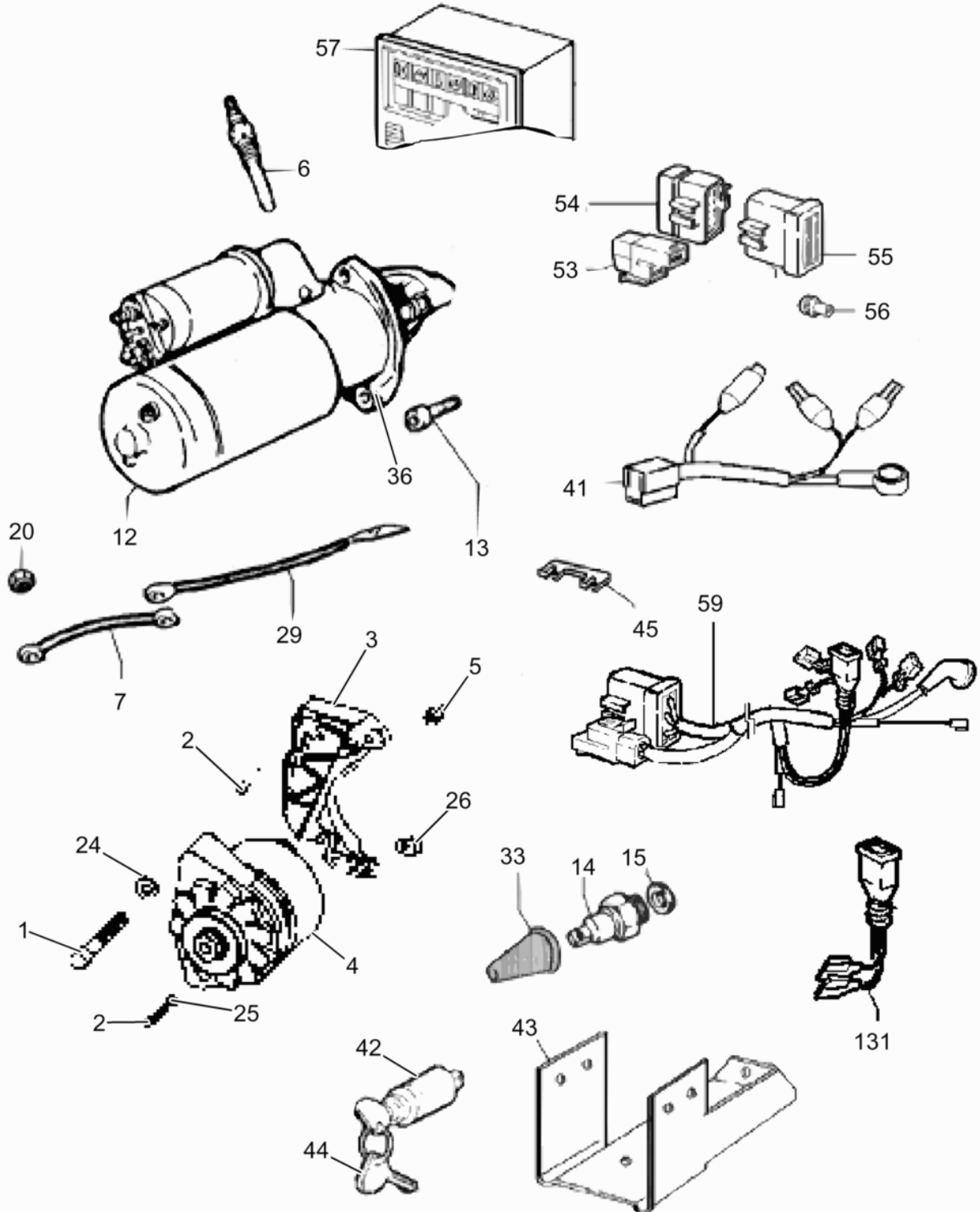

200_500015899502_11

Ref. Pos.	Part No. Artikel Nr.	Qty. St.	Description Beschreibung	Descripción Description	Measurement./Abm.	Norm
					Torque/Drehm.	Sealant Schmierstoff
55	5000160182	1	Connector Anschlußteil	Conector Connecteur		
56	5000160210	2	Guard Schutz	Protector Protection		
57	5200006800	1	Panel cpl. (with Key switch) Panel kpl. (mit Schlüsselschalter)	Panel compl. (con Interruptorde llave) Tableau compl. (avec Interrupt		
59	5200007545	1	Wiring harness Kabelbaum	Conjunto de cables Harnais de câbles électriques		
131	5000207005	1	Switch Schalter	Interruptor Interrupteur		

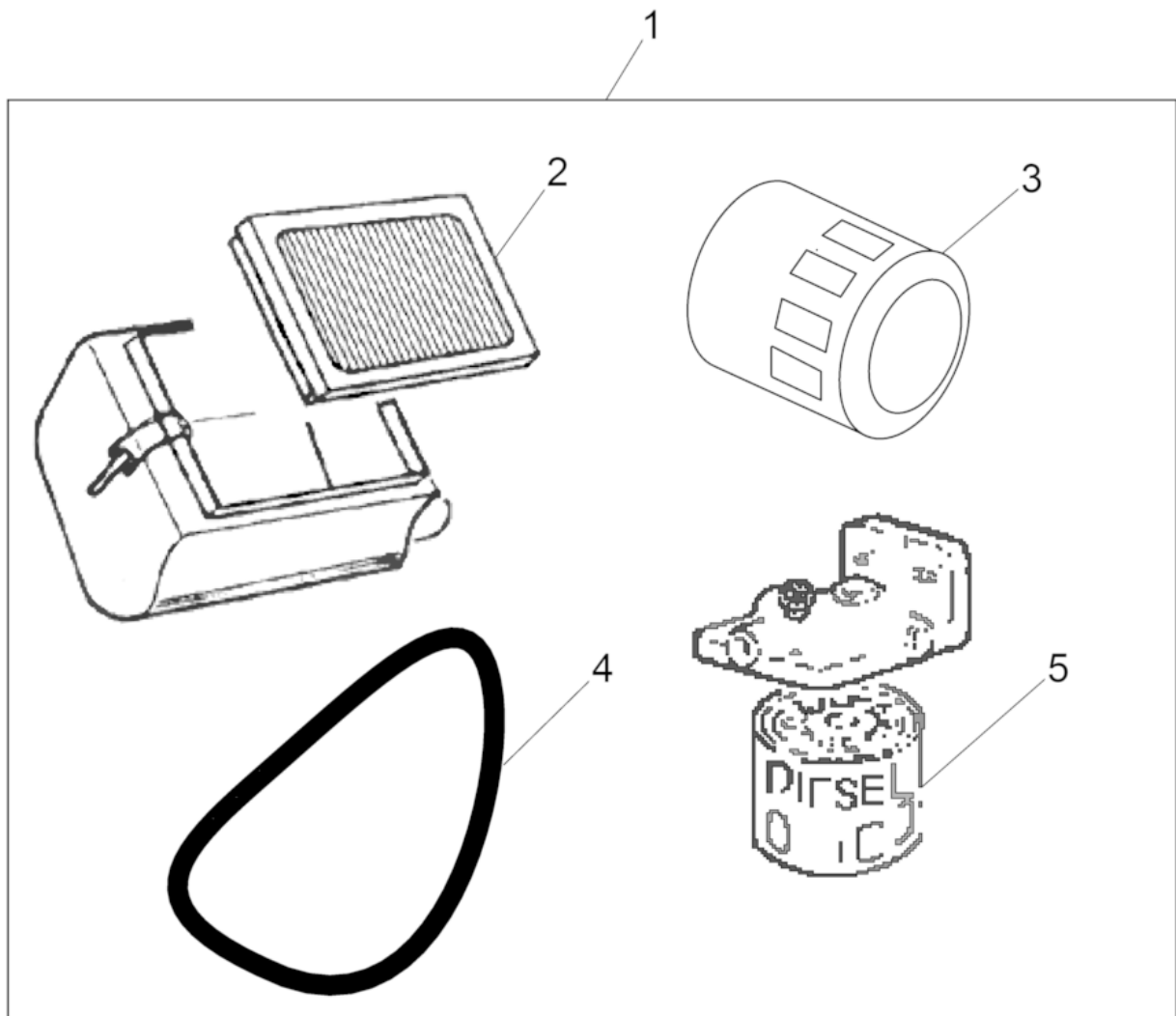

200_5200013122001001

Ref. Pos.	Part No. Artikel Nr.	Qty. St.	Description Beschreibung	Descripción Description	Measurement./Abm.	Norm
					Torque/Drehm.	Sealant Schmierstoff
1	5200013122	1	Maintenance kit Wartungssatz	Juego de reparación Jeu d'entretien		
2	5000155678	2	Air cleaner cartridge Luftfilterpatrone	Cartucho de filtro del aire Cartouche du filtre à air		
3	5000155736	4	Oil filter Ölfiter	Filtro de aceite Filtre d'huile		
4	5200002703	2	Alternator belt Lichtmaschinenriemen	Correa del alternador Courroie de l'alternateur	850mm	
5	5200009521	4	Element Element	Elemento Cartouche		



**WACKER
NEUSON**